



**THE DATASHEET OF
SN75159NSRE4**



SN75159 DUAL DIFFERENTIAL LINE DRIVER WITH 3-STATE OUTPUTS

SLLS088B – JANUARY 1977 – REVISED MAY 1995

- Meets or Exceeds the Requirements of ANSI EIA/TIA-422-B and ITU Recommendation V.11
- Single 5-V Supply
- Balanced Line Operation
- TTL Compatible
- High-Impedance Output State for Party-Line Applications
- High-Current Active-Pullup Outputs
- Short-Circuit Protection
- Dual Channels
- Clamp Diodes at Inputs

D OR N PACKAGE
(TOP VIEW)

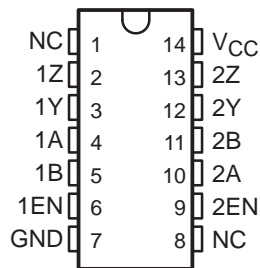

NC—No internal connection

description

The SN75159 dual differential line driver with 3-state outputs is designed to provide all the features of the SN75158 line driver with the added feature of driver output controls. There is an individual control for each driver. When the output control is low, the associated outputs are in a high-impedance state and the outputs can neither drive nor load the bus. This permits many devices to be connected together on the same transmission line for party-line applications.

The SN75159 is characterized for operation from 0°C to 70°C.

logic symbol†

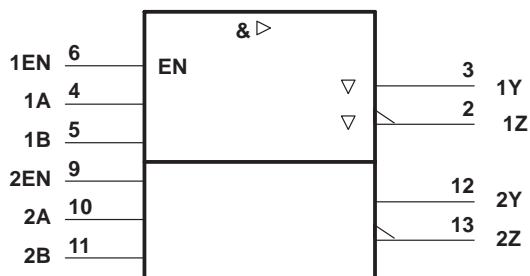

† This symbol is in accordance with ANSI/IEEE Std 91-1984 and IEC Publication 617-12.

logic diagram (positive logic)

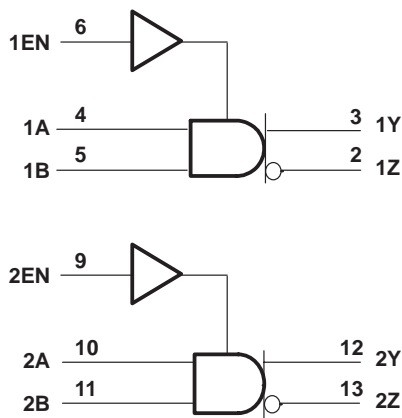

Please be aware that an important notice concerning availability, standard warranty, and use in critical applications of Texas Instruments semiconductor products and disclaimers thereto appears at the end of this data sheet.

PRODUCTION DATA information is current as of publication date. Products conform to specifications per the terms of Texas Instruments standard warranty. Production processing does not necessarily include testing of all parameters.

**TEXAS
INSTRUMENTS**

POST OFFICE BOX 655303 • DALLAS, TEXAS 75265

Copyright © 1995, Texas Instruments Incorporated

SN75159 DUAL DIFFERENTIAL LINE DRIVER WITH 3-STATE OUTPUTS

SLLS088B – JANUARY 1977 – REVISED MAY 1995

schematic (each driver)

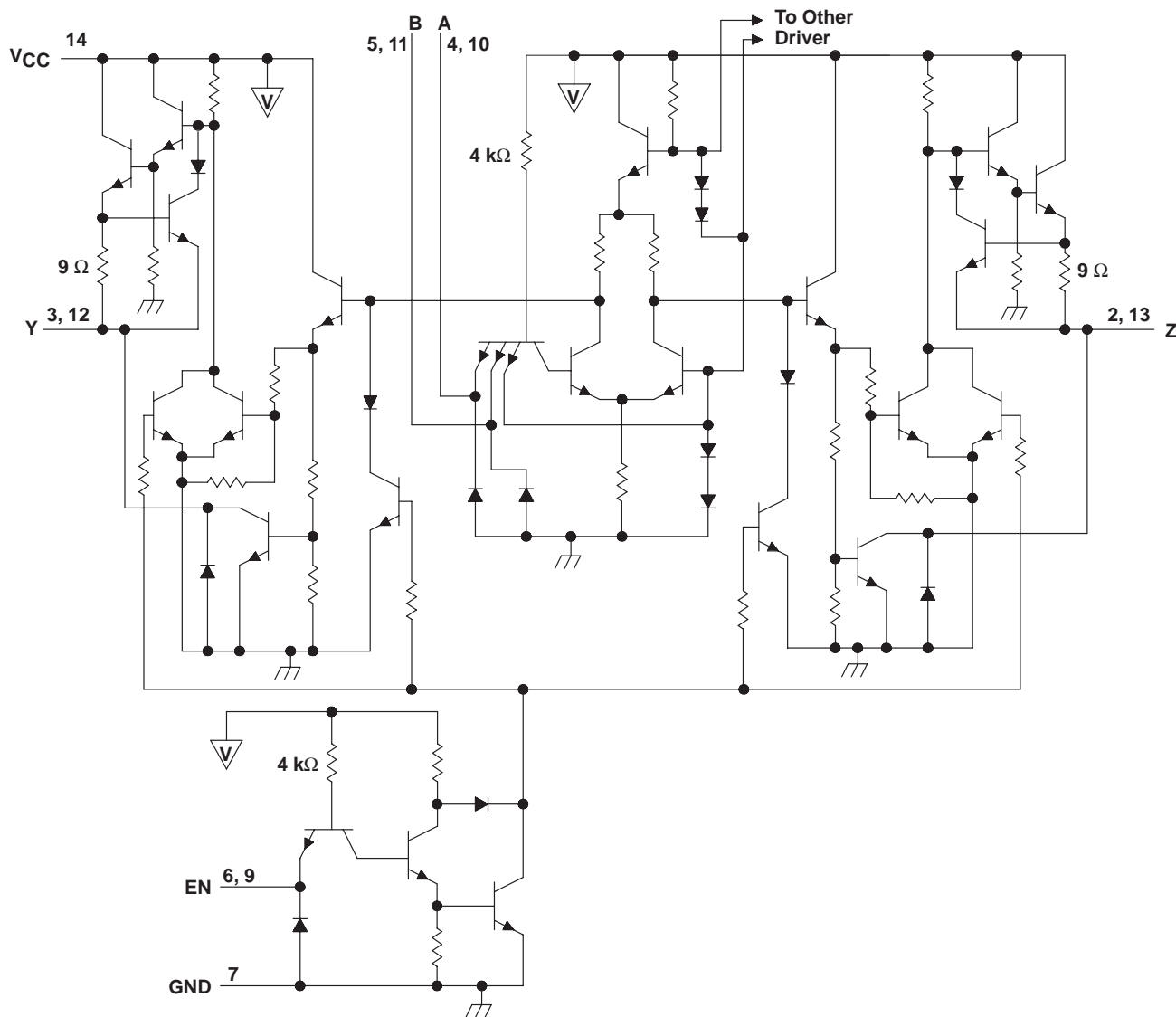

 ... VCC bus

Resistor values shown are nominal.

SN75159
DUAL DIFFERENTIAL LINE DRIVER
WITH 3-STATE OUTPUTS

SLLS088B – JANUARY 1977 – REVISED MAY 1995

absolute maximum ratings over operating free-air temperature range (unless otherwise noted)†

Supply voltage, V_{CC} (see Note 1)	7 V
Input voltage, V_I	5.5 V
Off-state voltage applied to open-collector outputs	12 V
Continuous total dissipation	See Dissipation Rating Table
Operating free-air temperature range, T_A	0°C to 70°C
Storage temperature range, T_{stg}	-65°C to 150°C
Lead temperature 1,6 mm (1/16 inch) from case for 10 seconds	260°C

† Stresses beyond those listed under “absolute maximum ratings” may cause permanent damage to the device. These are stress ratings only, and functional operation of the device at these or any other conditions beyond those indicated under “recommended operating conditions” is not implied. Exposure to absolute-maximum-rated conditions for extended periods may affect device reliability.

NOTE 1: All voltage values except differential output voltage V_{OD} are with respect to the network ground terminal. V_{OD} is at the Y output with respect to the Z output.

DISSIPATION RATING TABLE

PACKAGE	$T_A \leq 25^\circ\text{C}$ POWER RATING	DERATING FACTOR ABOVE $T_A = 25^\circ\text{C}$	$T_A = 70^\circ\text{C}$ POWER RATING
D	950 mW	7.6 mW/°C	608 mW
N	1150 mW	9.2 mW/°C	736 mW

recommended operating conditions

	MIN	NOM	MAX	UNIT
Supply voltage, V_{CC}	4.75	5	5.25	V
High-level input voltage, V_{IH}	2			V
Low-level input voltage, V_{IL}			0.8	V
High-level output voltage, I_{OH}			-40	mA
Low-level output current, I_{OL}			40	mA
Operating free-air temperature, T_A	0		70	°C



SN75159

DUAL DIFFERENTIAL LINE DRIVER WITH 3-STATE OUTPUTS

SLLS088B – JANUARY 1977 – REVISED MAY 1995

electrical characteristics over operating free-air temperature range (unless otherwise noted)

PARAMETER		TEST CONDITIONS		MIN	TYP†	MAX	UNIT
V_{IK}	Input clamp voltage	$V_{CC} = 4.75\text{ V}$,	$I_I = -12\text{ mA}$	-0.9	-1.5		V
V_{OH}	High-level output voltage	$V_{CC} = 4.75\text{ V}$, $V_{IH} = 2\text{ V}$,	$V_{IL} = 0.8\text{ V}$, $I_{OH} = -40\text{ mA}$	2.4	3		V
V_{OL}	Low-level output voltage	$V_{CC} = 4.75\text{ V}$, $V_{IH} = 2\text{ V}$,	$V_{IL} = 0.8\text{ V}$, $I_{OL} = 40\text{ mA}$		0.25	0.4	V
V_{OK}	Output clamp voltage	$V_{CC} = 5.25\text{ V}$,	$I_O = -40\text{ mA}$	-1.1	-1.5		V
V_O	Output voltage	$V_{CC} = 4.75\text{ V to } 5.25\text{ V}$,	$I_O = 0$	0		6	V
$ V_{OD1} $	Differential output voltage	$V_{CC} = 5.25\text{ V}$,	$I_O = 0$		3.5	$2V_{OD2}$	V
$ V_{OD2} $	Differential output voltage	$V_{CC} = 4.75\text{ V}$		2	3		V
$\Delta V_{OD} $	Change in magnitude of differential output voltage‡	$V_{CC} = 4.75\text{ V}$	$R_L = 100\ \Omega$, See Figure 1		± 0.02	± 0.4	V
V_{OC}	Common-mode output voltage§	$V_{CC} = 5.25\text{ V}$		1.8	3	V	
		$V_{CC} = 4.75\text{ V}$		1.5	3		
$\Delta V_{OC} $	Change in magnitude of common-mode output voltage‡	$V_{CC} = 4.75\text{ V to } 5.25\text{ V}$			± 0.01	± 0.4	V
I_O	Output current with power off	$V_{CC} = 0$	$V_O = 6\text{ V}$	0.1	100	μA	
			$V_O = -0.25\text{ V}$	-0.1	-100		
			$V_O = -0.25\text{ V to } 6\text{ V}$		± 100		
I_{OZ}	Off-state (high-impedance state) output current	$V_{CC} = 5.25\text{ V}$, Output controls at 0.8 V	$T_A = 25^\circ\text{C}$	$V_O = 0\text{ to } V_{CC}$	± 10	μA	
			$T_A = 70^\circ\text{C}$	$V_O = 0$	-20		
				$V_O = 0.4\text{ V}$	± 20		
				$V_O = 2.4\text{ V}$	± 20		
				$V_O = V_{CC}$	20		
I_I	Input current at maximum input voltage	$V_{CC} = 5.25\text{ V}$,	$V_I = 5.5\text{ V}$			1	mA
I_{IH}	High-level input current	$V_{CC} = 5.25\text{ V}$,	$V_I = 2.4\text{ V}$			40	μA
I_{IL}	Low-level input current	$V_{CC} = 5.25\text{ V}$,	$V_I = 0.4\text{ V}$		-1	-1.6	mA
I_{OS}	Short-circuit output current¶	$V_{CC} = 5.25\text{ V}$		-40	-90	-150	mA
I_{CC}	Supply current (both drivers)	$V_{CC} = 5.25\text{ V}$, $T_A = 25^\circ\text{C}$,	Inputs grounded, No load		47	65	mA

† All typical values are at $V_{CC} = 5\text{ V}$ and $T_A = 25^\circ\text{C}$ except for V_{OC} , for which V_{CC} is as stated under test conditions.

‡ $\Delta|V_{OD}|$ and $\Delta|V_{OC}|$ are the changes in magnitudes of V_{OD} and V_{OC} , respectively, that occur when the input is changed from a high level to a low level.

§ In ANSI Standard EIA/TIA-422-B, V_{OC} , which is the average of the two output voltages with respect to GND, is called output offset voltage, V_{OS} .

¶ Only one output should be shorted at a time, and duration of the short circuit should not exceed one second.

SN75159 DUAL DIFFERENTIAL LINE DRIVER WITH 3-STATE OUTPUTS

SLLS088B – JANUARY 1977 – REVISED MAY 1995

switching characteristics over operating free-air temperature range, $V_{CC} = 5\text{ V}$

PARAMETER		TEST CONDITIONS	MIN	TYP†	MAX	UNIT
t_{PLH}	Propagation delay time, low-to-high-level output	$C_L = 30\text{ pF}$, $R_L = 100\ \Omega$, See Figure 2, Termination A		16	25	ns
t_{PHL}	Propagation delay time, high-to-low-level output			11	20	ns
t_{PLH}	Propagation delay time, low-to-high-level output	$C_L = 15\text{ pF}$, See Figure 2, Termination B		13	20	ns
t_{PHL}	Propagation delay time, high-to-low-level output			9	15	ns
t_{TLH}	Transition time, low-to-high-level output	$C_L = 30\text{ pF}$, $R_L = 100\ \Omega$, See Figure 2, Termination A		4	20	ns
t_{THL}	Transition time, high-to-low-level output			4	20	ns
t_{PZH}	Output enable time to high level	$C_L = 30\text{ pF}$, $R_L = 180\ \Omega$, See Figure 3		7	20	ns
t_{PZL}	Output enable time to low level	$C_L = 30\text{ pF}$, $R_L = 250\ \Omega$, See Figure 4		14	40	ns
t_{PHZ}	Output disable time from high level	$C_L = 30\text{ pF}$, $R_L = 180\ \Omega$, See Figure 3		10	30	ns
t_{PLZ}	Output disable time from low level	$C_L = 30\text{ pF}$, $R_L = 250\ \Omega$, See Figure 4		17	35	ns
Overshoot factor		$R_L = 100\ \Omega$, See Figure 2, Termination C			10%	

† All typical values are at $T_A = 25^\circ\text{C}$.

SYMBOL EQUIVALENTS

DATA-SHEET PARAMETER	EIA/TIA-422-B
V_O	V_{oa}, V_{ob}
$ V_{OD1} $	V_o
$ V_{OD2} $	V_t
$\Delta V_{OD} $	$ V_t - \bar{V}_t $
V_{OC}	$ V_{os} $
$\Delta V_{OC} $	$ V_{os} - \bar{V}_{os} $
I_{OS}	$ I_{sa} , I_{sb} $
I_O	$ I_{xa} , I_{xb} $

PARAMETER MEASUREMENT INFORMATION

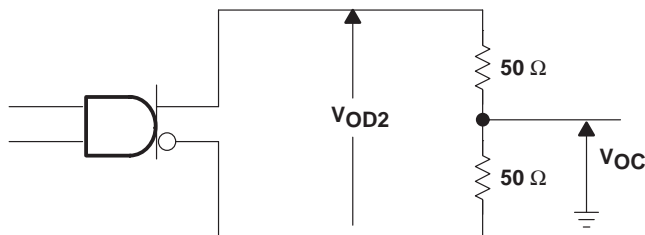
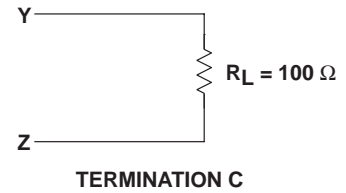
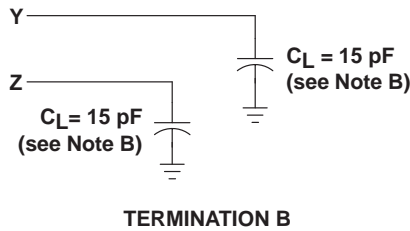
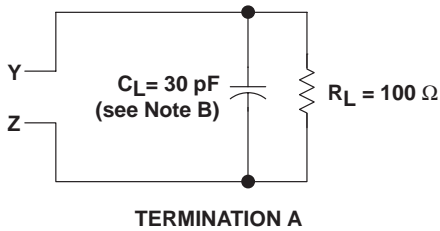
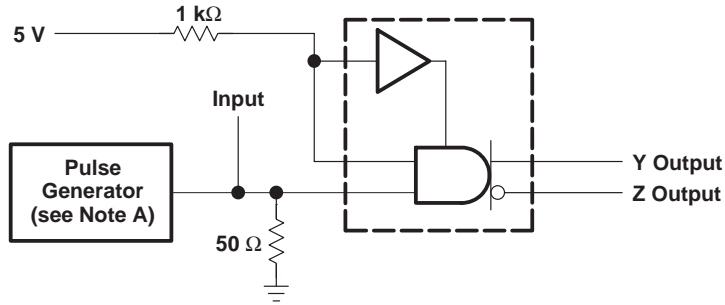

Figure 1. Differential and Common-Mode Output Voltages

SN75159
DUAL DIFFERENTIAL LINE DRIVER
WITH 3-STATE OUTPUTS

SLLS088B – JANUARY 1977 – REVISED MAY 1995

PARAMETER MEASUREMENT INFORMATION



TEST CIRCUITS

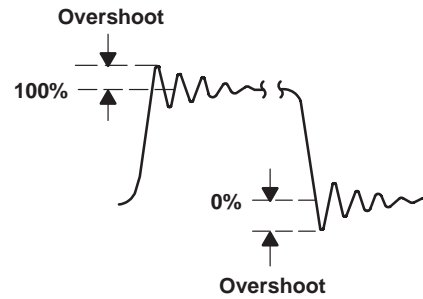
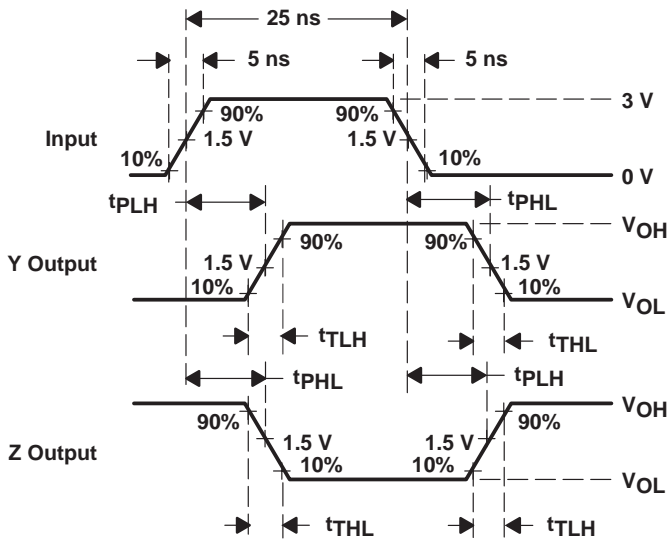

VOLTAGE WAVEFORMS

- NOTES: A. The pulse generator has the following characteristics: $Z_O = 50 \Omega$, $PRR \leq 10 \text{ MHz}$.
 B. C_L includes probe and jig capacitance.

Figure 2. Test Circuits, Voltage Waveforms, and Overshoot Factor

PARAMETER MEASUREMENT INFORMATION

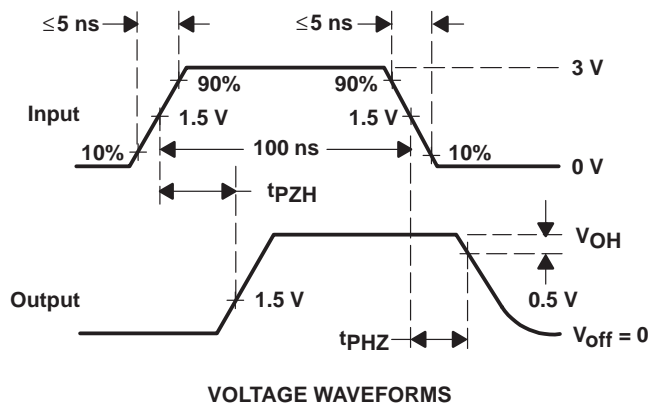
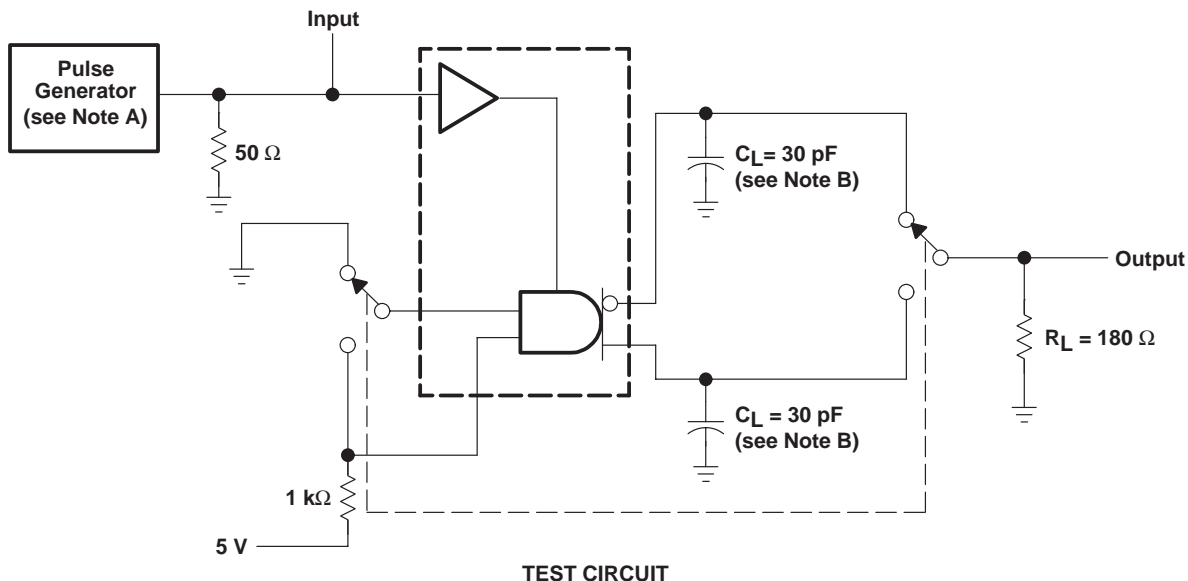

- NOTES: A. The pulse generator has the following characteristics: $Z_O = 50 \Omega$, $PRR \leq 500 \text{ kHz}$.
 B. C_L includes probe and jig capacitance.

Figure 3. Test Circuit and Voltage Waveforms

SN75159
DUAL DIFFERENTIAL LINE DRIVER
WITH 3-STATE OUTPUTS

SLLS088B – JANUARY 1977 – REVISED MAY 1995

PARAMETER MEASUREMENT INFORMATION

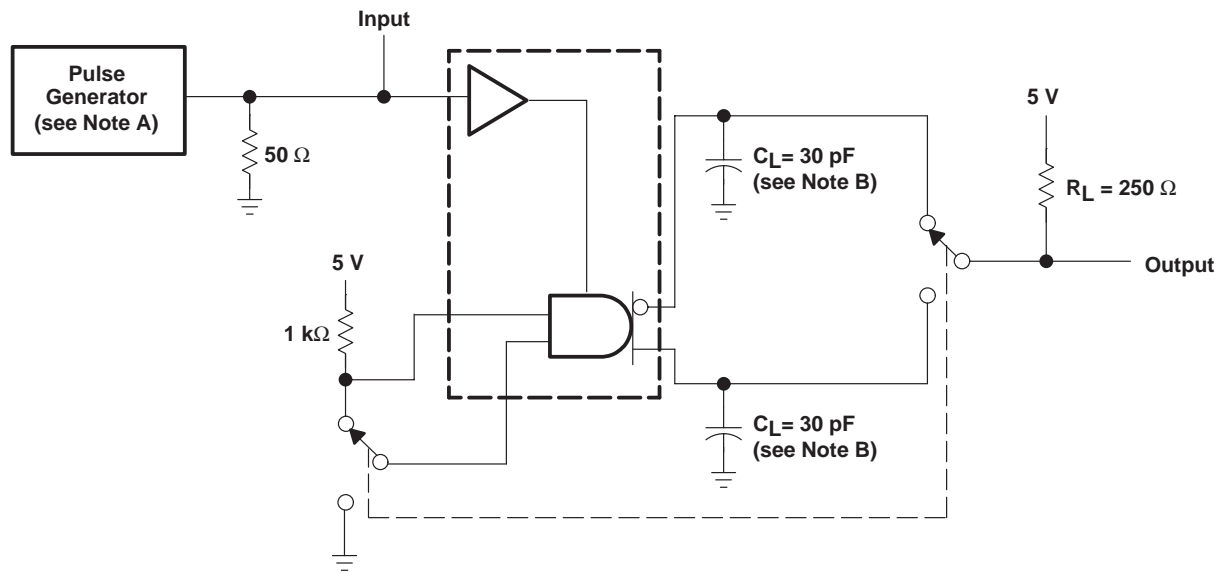

TEST CIRCUIT

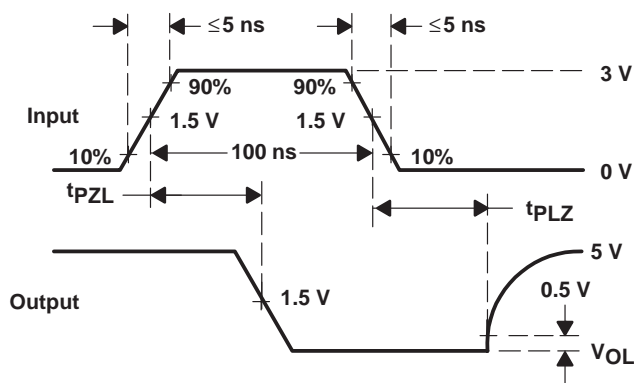

VOLTAGE WAVEFORMS

- NOTES: A. The pulse generator has the following characteristics: $Z_O = 50 \Omega$, $PRR \leq 500 \text{ kHz}$.
 B. C_L includes probe and jig capacitance.

Figure 4. Test Circuit and Voltage Waveform

TYPICAL CHARACTERISTICS

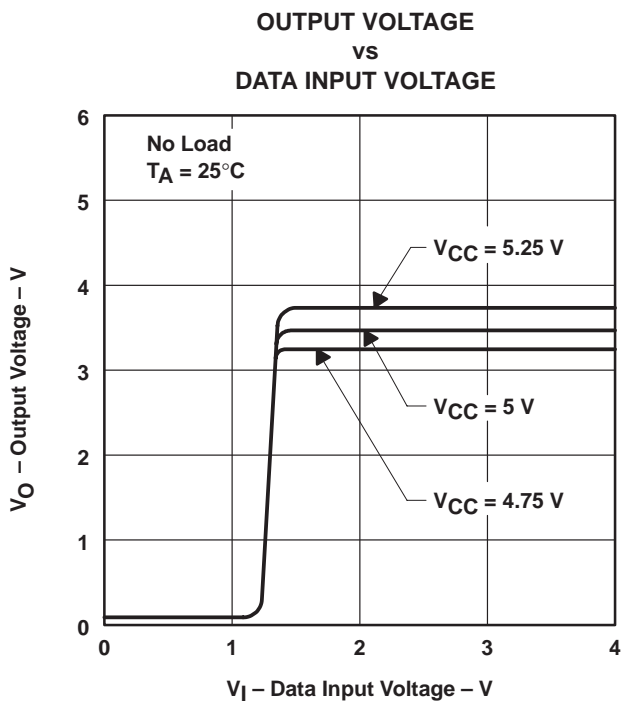

Figure 5

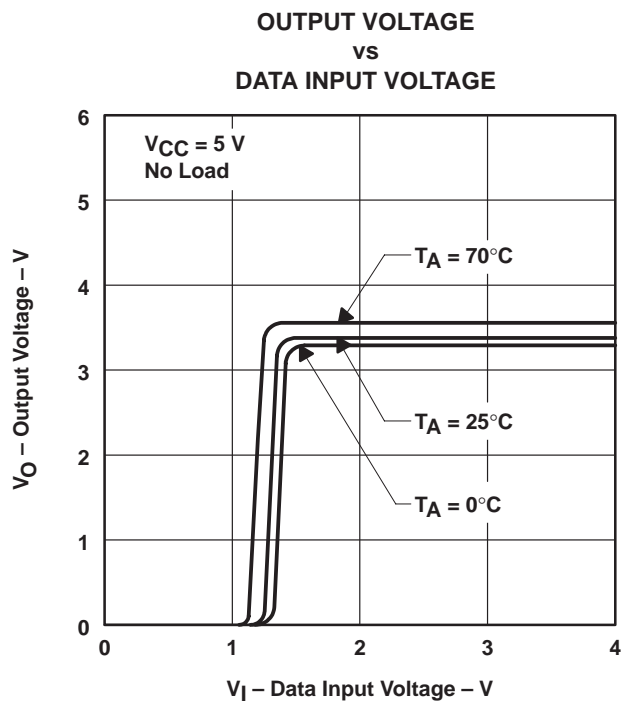

Figure 6

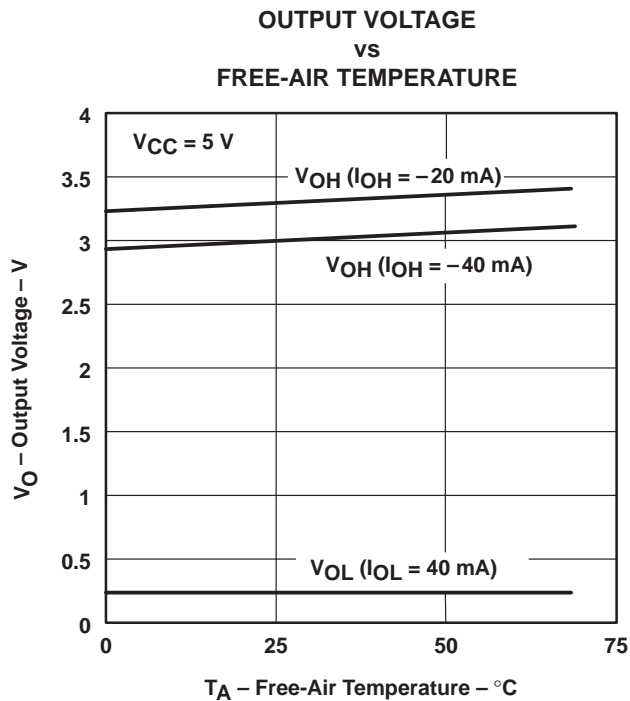

Figure 7

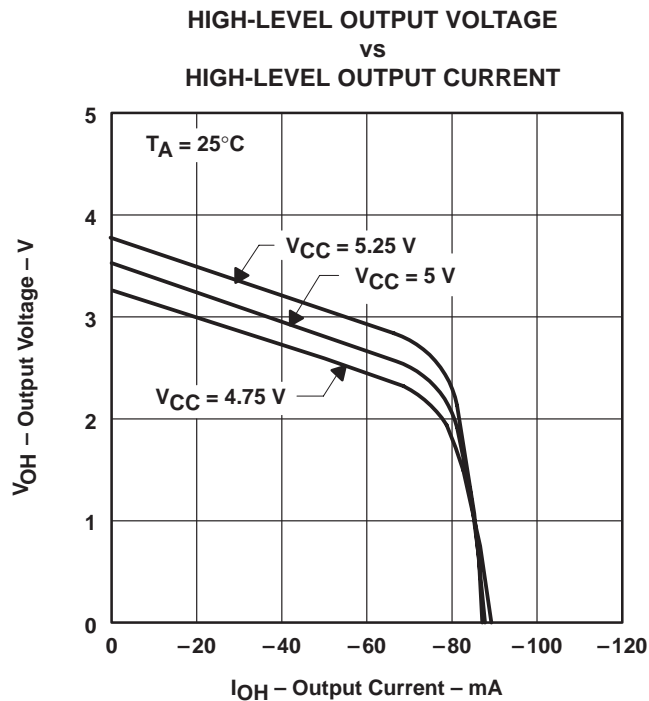

Figure 8

SN75159
DUAL DIFFERENTIAL LINE DRIVER
WITH 3-STATE OUTPUTS

SLLS088B – JANUARY 1977 – REVISED MAY 1995

TYPICAL CHARACTERISTICS

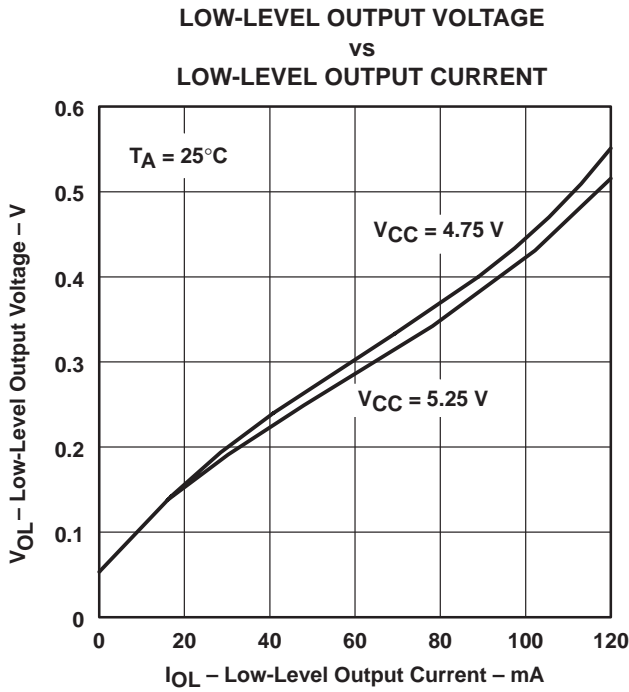

Figure 9

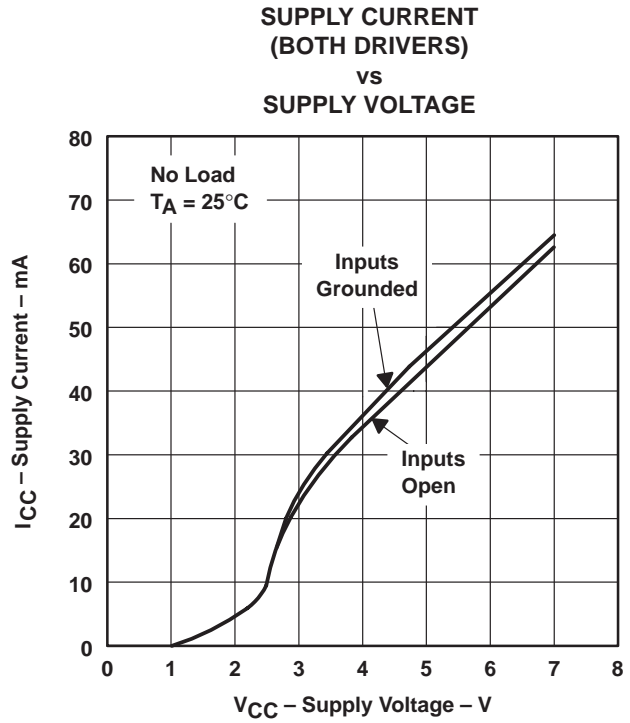

Figure 10

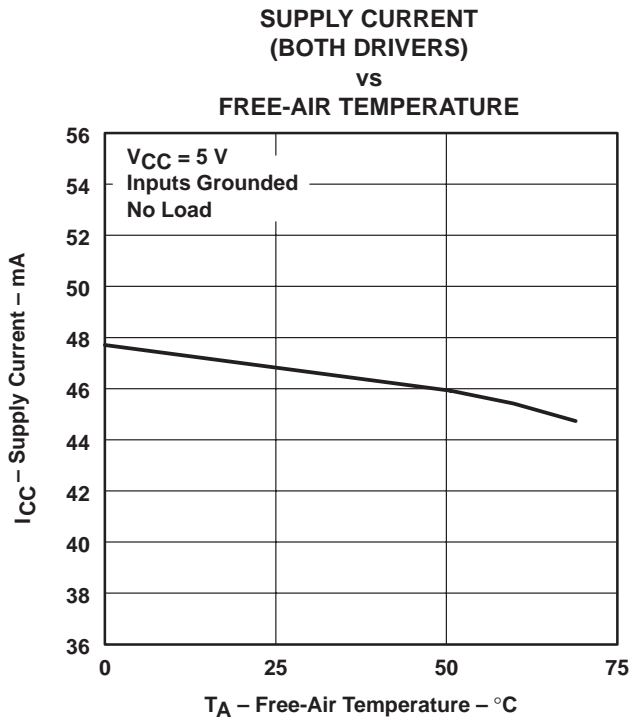

Figure 11

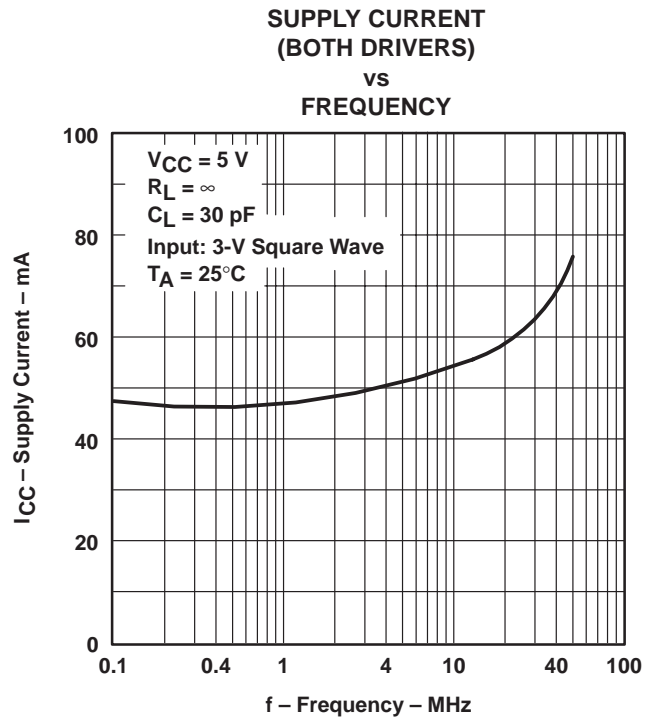

Figure 12



TYPICAL CHARACTERISTICS

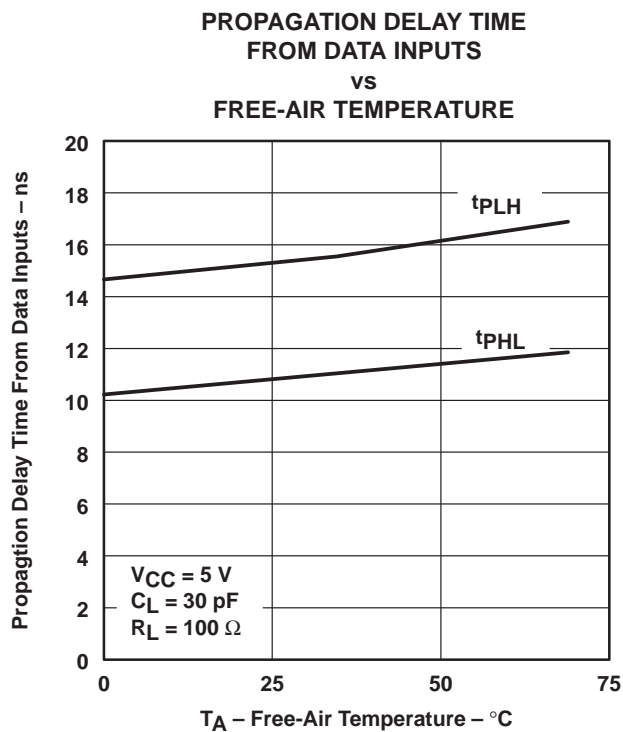

Figure 13

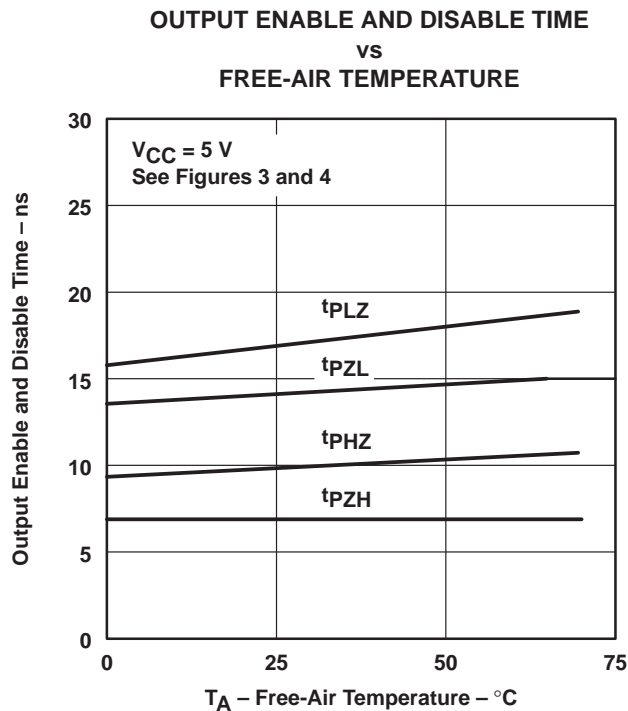

Figure 14

PACKAGING INFORMATION

Orderable Device	Status (1)	Package Type	Package Drawing	Pins	Package Qty	Eco Plan (2)	Lead finish/ Ball material (6)	MSL Peak Temp (3)	Op Temp (°C)	Device Marking (4/5)	Samples
SN75159D	ACTIVE	SOIC	D	14	50	RoHS & Green	NIPDAU	Level-1-260C-UNLIM	0 to 70	SN75159	Samples
SN75159N	ACTIVE	PDIP	N	14	25	RoHS & Green	NIPDAU	N / A for Pkg Type	0 to 70	SN75159N	Samples

(1) The marketing status values are defined as follows:

ACTIVE: Product device recommended for new designs.

LIFEBUY: TI has announced that the device will be discontinued, and a lifetime-buy period is in effect.

NRND: Not recommended for new designs. Device is in production to support existing customers, but TI does not recommend using this part in a new design.

PREVIEW: Device has been announced but is not in production. Samples may or may not be available.

OBSELETE: TI has discontinued the production of the device.

(2) **RoHS:** TI defines "RoHS" to mean semiconductor products that are compliant with the current EU RoHS requirements for all 10 RoHS substances, including the requirement that RoHS substance do not exceed 0.1% by weight in homogeneous materials. Where designed to be soldered at high temperatures, "RoHS" products are suitable for use in specified lead-free processes. TI may reference these types of products as "Pb-Free".

RoHS Exempt: TI defines "RoHS Exempt" to mean products that contain lead but are compliant with EU RoHS pursuant to a specific EU RoHS exemption.

Green: TI defines "Green" to mean the content of Chlorine (Cl) and Bromine (Br) based flame retardants meet JS709B low halogen requirements of <=1000ppm threshold. Antimony trioxide based flame retardants must also meet the <=1000ppm threshold requirement.

(3) MSL, Peak Temp. - The Moisture Sensitivity Level rating according to the JEDEC industry standard classifications, and peak solder temperature.

(4) There may be additional marking, which relates to the logo, the lot trace code information, or the environmental category on the device.

(5) Multiple Device Markings will be inside parentheses. Only one Device Marking contained in parentheses and separated by a "~" will appear on a device. If a line is indented then it is a continuation of the previous line and the two combined represent the entire Device Marking for that device.

(6) Lead finish/Ball material - Orderable Devices may have multiple material finish options. Finish options are separated by a vertical ruled line. Lead finish/Ball material values may wrap to two lines if the finish value exceeds the maximum column width.

Important Information and Disclaimer:The information provided on this page represents TI's knowledge and belief as of the date that it is provided. TI bases its knowledge and belief on information provided by third parties, and makes no representation or warranty as to the accuracy of such information. Efforts are underway to better integrate information from third parties. TI has taken and continues to take reasonable steps to provide representative and accurate information but may not have conducted destructive testing or chemical analysis on incoming materials and chemicals. TI and TI suppliers consider certain information to be proprietary, and thus CAS numbers and other limited information may not be available for release.

In no event shall TI's liability arising out of such information exceed the total purchase price of the TI part(s) at issue in this document sold by TI to Customer on an annual basis.

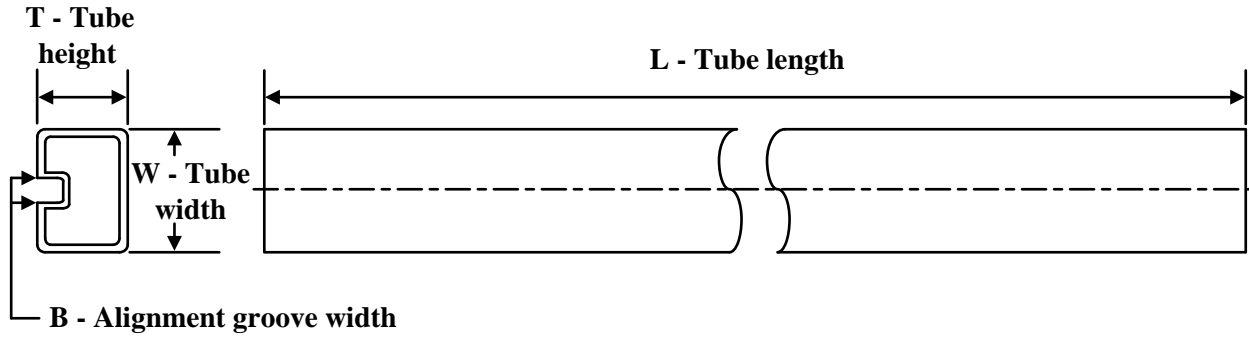
TUBE

*All dimensions are nominal

Device	Package Name	Package Type	Pins	SPQ	L (mm)	W (mm)	T (μm)	B (mm)
SN75159D	D	SOIC	14	50	506.6	8	3940	4.32
SN75159N	N	PDIP	14	25	506	13.97	11230	4.32

D (R-PDSO-G14)

PLASTIC SMALL OUTLINE



- NOTES:
- A. All linear dimensions are in inches (millimeters).
 - B. This drawing is subject to change without notice.
 - Body length does not include mold flash, protrusions, or gate burrs. Mold flash, protrusions, or gate burrs shall not exceed 0.006 (0,15) each side.
 - Body width does not include interlead flash. Interlead flash shall not exceed 0.017 (0,43) each side.
 - E. Reference JEDEC MS-012 variation AB.

D (R-PDSO-G14)

PLASTIC SMALL OUTLINE



4211283-3/E 08/12

- NOTES:
- All linear dimensions are in millimeters.
 - This drawing is subject to change without notice.
 - Publication IPC-7351 is recommended for alternate designs.
 - Laser cutting apertures with trapezoidal walls and also rounding corners will offer better paste release. Customers should contact their board assembly site for stencil design recommendations. Refer to IPC-7525 for other stencil recommendations.
 - Customers should contact their board fabrication site for solder mask tolerances between and around signal pads.

N (R-PDIP-T**)

PLASTIC DUAL-IN-LINE PACKAGE

16 PINS SHOWN



- NOTES:
- A. All linear dimensions are in inches (millimeters).
 - B. This drawing is subject to change without notice.
 - Falls within JEDEC MS-001, except 18 and 20 pin minimum body length (Dim A).
 - The 20 pin end lead shoulder width is a vendor option, either half or full width.

IMPORTANT NOTICE AND DISCLAIMER

TI PROVIDES TECHNICAL AND RELIABILITY DATA (INCLUDING DATA SHEETS), DESIGN RESOURCES (INCLUDING REFERENCE DESIGNS), APPLICATION OR OTHER DESIGN ADVICE, WEB TOOLS, SAFETY INFORMATION, AND OTHER RESOURCES "AS IS" AND WITH ALL FAULTS, AND DISCLAIMS ALL WARRANTIES, EXPRESS AND IMPLIED, INCLUDING WITHOUT LIMITATION ANY IMPLIED WARRANTIES OF MERCHANTABILITY, FITNESS FOR A PARTICULAR PURPOSE OR NON-INFRINGEMENT OF THIRD PARTY INTELLECTUAL PROPERTY RIGHTS.

These resources are intended for skilled developers designing with TI products. You are solely responsible for (1) selecting the appropriate TI products for your application, (2) designing, validating and testing your application, and (3) ensuring your application meets applicable standards, and any other safety, security, regulatory or other requirements.

These resources are subject to change without notice. TI grants you permission to use these resources only for development of an application that uses the TI products described in the resource. Other reproduction and display of these resources is prohibited. No license is granted to any other TI intellectual property right or to any third party intellectual property right. TI disclaims responsibility for, and you will fully indemnify TI and its representatives against, any claims, damages, costs, losses, and liabilities arising out of your use of these resources.

TI's products are provided subject to [TI's Terms of Sale](#) or other applicable terms available either on [ti.com](https://www.ti.com) or provided in conjunction with such TI products. TI's provision of these resources does not expand or otherwise alter TI's applicable warranties or warranty disclaimers for TI products.

TI objects to and rejects any additional or different terms you may have proposed.

Mailing Address: Texas Instruments, Post Office Box 655303, Dallas, Texas 75265
Copyright © 2024, Texas Instruments Incorporated

Looking for pricing, stock, or lifecycle information?

Click below to explore more details on WIN SOURCE:

 [View SN75159NSRE4 on WIN SOURCE](#)

 [Texas Instruments](#) Information

Optimize Your Supply Chain with WIN SOURCE Solutions

-  Global Sourcing Solution
-  Obsolete Management
-  Cost Control Management
-  Shortage Management
-  Alternative Solution
-  Excess Inventory Management