



**THE DATASHEET OF
SN65LVDM051QDG4Q1**



SN65LVDM050-Q1, SN65LVDM051-Q1 HIGH-SPEED DIFFERENTIAL LINE DRIVERS AND RECEIVERS

SGLS128A – JULY 2002 – REVISED APRIL 2008

- Qualified for Automotive Applications
- ESD Protection Exceeds 2000 V Per MIL-STD-883, Method 3015; Exceeds 200 V Using Machine Model (C = 200 pF, R = 0)
- Low-Voltage Differential 50-Ω Line Drivers and Receivers
- Signaling Rates up to 500 Mbps
- Bus-Terminal ESD Exceeds 12 kV
- Operates From a Single 3.3 V Supply
- Low-Voltage Differential Signaling With Typical Output Voltages of 340 mV With a 50-Ω Load
- Valid Output With as Little as 50-mV Input Voltage Difference
- Propagation Delay Times
 - Driver: 1.7 ns Typ
 - Receiver: 3.7 ns Typ
- Power Dissipation at 200 MHz
 - Driver: 50 mW Typical
 - Receiver: 60 mW Typical
- LVTTTL Input Levels Are 5 V Tolerant
- Driver Is High Impedance When Disabled or With $V_{CC} < 1.5$ V
- Receiver Has Open-Circuit Fail Safe

SN65LVDM050QDQ1 (Marked as LVDM050Q)
(TOP VIEW)

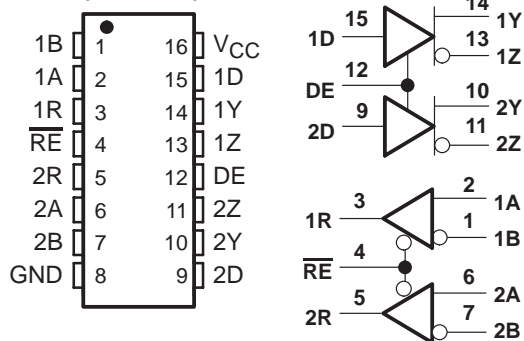

SN65LVDM051QDQ1 (Marked as LVDM051Q)
(TOP VIEW)

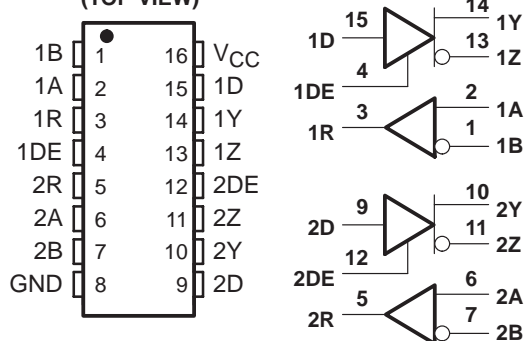

description

The SN65LVDM050, and SN65LVDM051 are differential line drivers and receivers that use low-voltage differential signaling (LVDS) to achieve signaling rates as high as 500 Mbps (per TIA/EIA-644 definition). These circuits are similar to TIA/EIA-644 standard compliant devices (SN65LVDS) counterparts, except that the output current of the drivers is doubled. This modification provides a minimum differential output voltage magnitude of 247 mV across a 50-Ω load simulating two transmission lines in parallel. This allows having data buses with more than one driver or with two line termination resistors. The receivers detect a voltage difference of 50 mV with up to 1 V of ground potential difference between a transmitter and receiver.

The intended application of these devices and signaling techniques is point-to-point and multipoint, baseband data transmission over a controlled impedance media of approximately 100 Ω of characteristic impedance. The transmission media may be printed-circuit board traces, backplanes, or cables.



Please be aware that an important notice concerning availability, standard warranty, and use in critical applications of Texas Instruments semiconductor products and disclaimers thereto appears at the end of this data sheet.

PRODUCTION DATA information is current as of publication date. Products conform to specifications per the terms of Texas Instruments standard warranty. Production processing does not necessarily include testing of all parameters.

 **TEXAS
INSTRUMENTS**

POST OFFICE BOX 655303 • DALLAS, TEXAS 75265

Copyright © 2008 Texas Instruments Incorporated

SN65LVDM050-Q1, SN65LVDM051-Q1 HIGH-SPEED DIFFERENTIAL LINE DRIVERS AND RECEIVERS

SGLS128A – JULY 2002 – REVISED APRIL 2008

description (continued)

The SN65LVDM050Q and SN65LVDM051Q are characterized for operation from -40°C to 125°C . Additionally, Q1 suffixed parts are qualified in accordance with AEC-Q100 stress test qualification for integrated circuits.

AVAILABLE OPTIONS†

T _A	PACKAGE‡
	SMALL OUTLINE (D)
-40°C to 125°C	SN65LVDM050QDQ1
	SN65LVDM051QDQ1

† For the most current package and ordering information, see the Package Option Addendum at the end of this document, or see the TI web site at <http://www.ti.com>.

‡ Package drawings, thermal data, and symbolization are available at <http://www.ti.com/packaging>.

NOTE:

The ultimate rate and distance of data transfer is dependent upon the attenuation characteristics of the media, the noise coupling to the environment, and other application-specific characteristics.

Function Tables

SN65LVDM050 and SN65LVDM051 RECEIVER

INPUTS		OUTPUT
$V_{ID} = V_A - V_B$	\overline{RE}	R
$V_{ID} \geq 50\text{ mV}$	L	H
$-50\text{ mV} < V_{ID} < 50\text{ mV}$	L	?
$V_{ID} \leq -50\text{ mV}$	L	L
Open	L	H
X	H	Z

H = high level, L = low level, Z = high impedance, X = don't care

Function Tables (Continued)

SN65LVDM050 and SN65LVDM051 DRIVER

INPUTS		OUTPUTS	
D	DE	Y	Z
L	H	L	H
H	H	H	L
Open	H	L	H
X	L	Z	Z

H = high level, L = low level, Z = high impedance, X = don't care

SN65LVDM050-Q1, SN65LVDM051-Q1 HIGH-SPEED DIFFERENTIAL LINE DRIVERS AND RECEIVERS

SGLS128A – JULY 2002 – REVISED APRIL 2008

equivalent input and output schematic diagrams

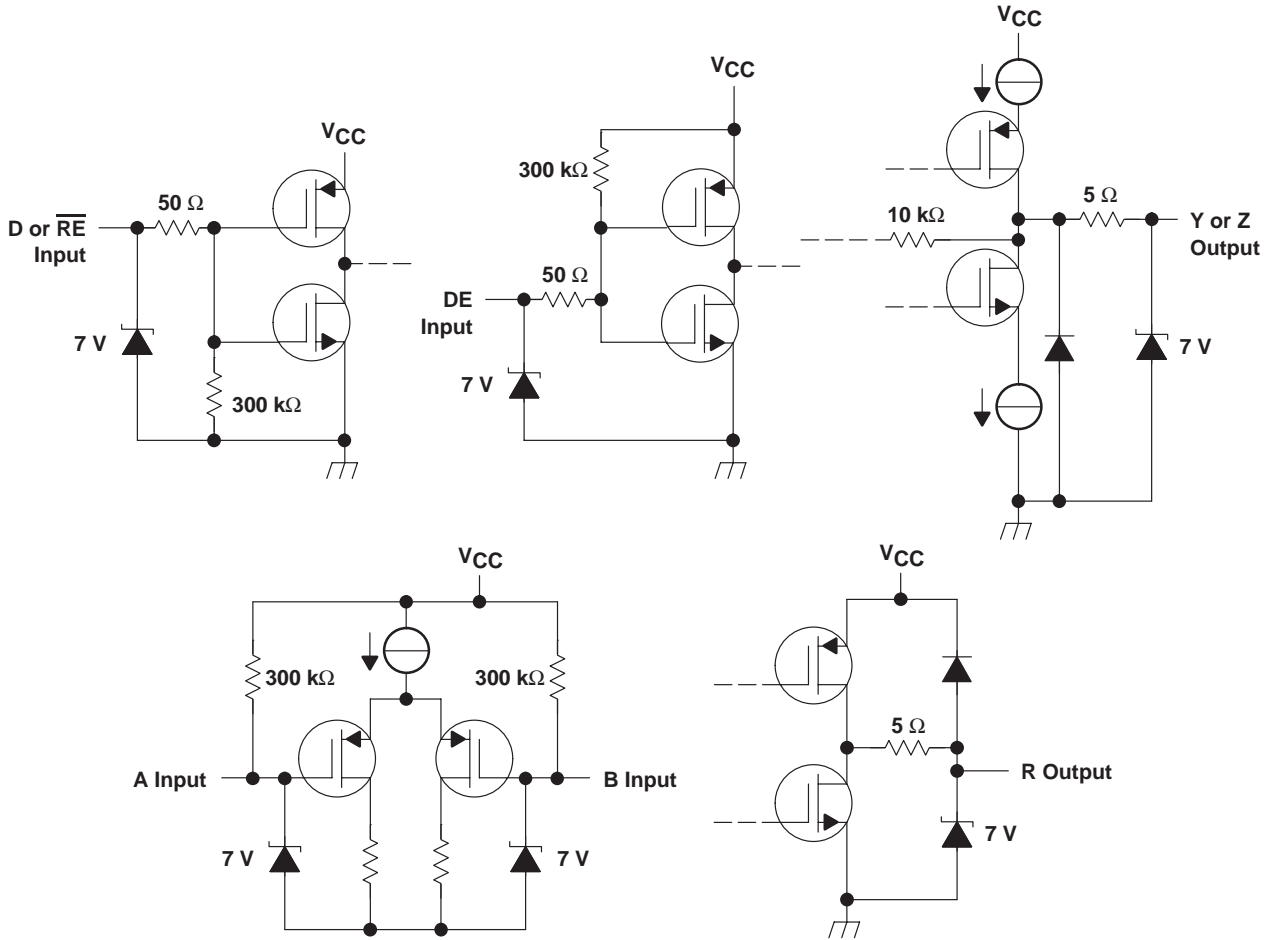

SN65LVDM050-Q1, SN65LVDM051-Q1 HIGH-SPEED DIFFERENTIAL LINE DRIVERS AND RECEIVERS

SGLS128A – JULY 2002 – REVISED APRIL 2008

absolute maximum ratings over operating free-air temperature (unless otherwise noted)†

Supply voltage range, V_{CC} (see Note 1)	–0.5 V to 4 V
Voltage range (D, R, DE, \overline{RE})	–0.5 V to 6 V
Voltage range (Y, Z, A, and B)	–0.5 V to 4 V
Electrostatic discharge: Y, Z, A, B, and GND (see Note 2)	Class 3, A:12 kV, B:600 V
All	Class 3, A:7 kV, B:500 V
Continuous power dissipation	see dissipation rating table
Storage temperature range	–65°C to 150°C
Lead temperature 1,6 mm (1/16 inch) from case for 10 seconds	250°C

† Stresses beyond those listed under “absolute maximum ratings” may cause permanent damage to the device. These are stress ratings only, and functional operation of the device at these or any other conditions beyond those indicated under “recommended operating conditions” is not implied. Exposure to absolute-maximum-rated conditions for extended periods may affect device reliability.

- NOTES: 1. All voltage values, except differential I/O bus voltages, are with respect to network ground terminal.
2. Tested in accordance with MIL-STD-883C Method 3015.7.

DISSIPATION RATING TABLE

PACKAGE	$T_A \leq 25^\circ\text{C}$ POWER RATING	DERATING FACTOR ABOVE $T_A = 25^\circ\text{C}$ ‡	$T_A = 85^\circ\text{C}$ POWER RATING	$T_A = 125^\circ\text{C}$ POWER RATING
D(8)	635 mW	5.1 mW/°C	330 mW	—
D(14)	987 mW	7.9 mW/°C	513 mW	—
D(16)	1110 mW	8.9 mW/°C	577 mW	223 mW
DGK	424 mW	3.4 mW/°C	220 mW	—
PW (14)	736 mW	5.9 mW/°C	383 mW	—
PW (16)	839 mW	6.7 mW/°C	437 mW	—

‡ This is the inverse of the junction-to-ambient thermal resistance when board-mounted and with no air flow.

recommended operating conditions

	MIN	NOM	MAX	UNIT
Supply voltage, V_{CC}	3	3.3	3.6	V
High-level input voltage, V_{IH}	2			V
Low-level input voltage, V_{IL}			0.8	V
Magnitude of differential input voltage, $ V_{ID} $	0.1		0.6	V
Common-mode input voltage, V_{IC} (see Figure 6)	$\frac{ V_{ID} }{2}$		$2.4 - \frac{ V_{ID} }{2}$	V
			$V_{CC} - 0.8$	
Operating free-air temperature, T_A	–40		125	°C

device electrical characteristics over recommended operating conditions (unless otherwise noted)

PARAMETER		TEST CONDITIONS	MIN	TYP†	MAX	UNIT
I_{CC} Supply current	SN65LVDM050	Drivers and receivers enabled, no receiver loads, driver $R_L = 50 \Omega$		19	27	mA
		Drivers enabled, receivers disabled, $R_L = 50 \Omega$		16	24	
		Drivers disabled, receivers enabled, no loads		4	6	
		Disabled		0.5	1	
	SN65LVDM051	Drivers enabled, no receiver loads, driver $R_L = 50 \Omega$		19	27	mA
		Drivers disabled, No loads		4	6	

† All typical values are at 25°C and with a 3.3 V supply.



SN65LVDM050-Q1, SN65LVDM051-Q1 HIGH-SPEED DIFFERENTIAL LINE DRIVERS AND RECEIVERS

SGLS128A – JULY 2002 – REVISED APRIL 2008

driver electrical characteristics over recommended operating conditions (unless otherwise noted)

PARAMETER		TEST CONDITIONS	MIN	TYP	MAX	UNIT
$ V_{OD} $	Differential output voltage magnitude	$R_L = 50 \Omega$, See Figure 1 and Figure 2	247	340	454	mV
$\Delta V_{OD} $	Change in differential output voltage magnitude between logic states		-50		50	
$V_{OC(SS)}$	Steady-state common-mode output voltage	See Figure 3	1.125	1.2	1.375	V
$\Delta V_{OC(SS)}$	Change in steady-state common-mode output voltage between logic states		-50		50	mV
$V_{OC(PP)}$	Peak-to-peak common-mode output voltage			50		mV
I_{IH}	High-level input current	$V_{IH} = 5 V$	DE	-0.5	-20	μA
			D		2	
I_{IL}	Low-level input current	$V_{IL} = 0.8 V$	DE	-0.5	-10	μA
			D		2	
I_{OS}	Short-circuit output current	V_{OY} or $V_{OZ} = 0 V$		7	10	mA
		$V_{OD} = 0 V$		7	10	
I_{OZ}	High-impedance output current	$V_{OD} = 600 mV$			± 1	μA
		$V_O = 0 V$ or V_{CC}			± 1	
$I_{O(OFF)}$	Power-off output current	$V_{CC} = 0 V$, $V_O = 3.6 V$			± 1.5	μA
C_{IN}	Input capacitance			3		pF

receiver electrical characteristics over recommended operating conditions (unless otherwise noted)

PARAMETER		TEST CONDITIONS	MIN	TYP†	MAX	UNIT
V_{IT+}	Positive-going differential input voltage threshold	See Figure 4 and Table 1			50	mV
V_{IT-}	Negative-going differential input voltage threshold		-50			
V_{OH}	High-level output voltage	$I_{OH} = -8 mA$	2.4			V
V_{OL}	Low-level output voltage	$I_{OL} = 8 mA$			0.4	V
I_I	Input current (A or B inputs)	$V_I = 0$	-2	-11	-20	μA
		$V_I = 2.4 V$	-1.2	-3		
$I_{I(OFF)}$	Power-off input current (A or B inputs)	$V_{CC} = 0$			± 20	μA
I_{IH}	High-level input current (enables)	$V_{IH} = 5 V$			10	μA
I_{IL}	Low-level input current (enables)	$V_{IL} = 0.8 V$			10	μA
I_{OZ}	High-impedance output current	$V_O = 0$ or $5 V$			± 10	μA
C_I	Input capacitance			5		pF

† All typical values are at 25°C and with a 3.3-V supply.

SN65LVDM050-Q1, SN65LVDM051-Q1 HIGH-SPEED DIFFERENTIAL LINE DRIVERS AND RECEIVERS

SGLS128A – JULY 2002 – REVISED APRIL 2008

driver switching characteristics over recommended operating conditions (unless otherwise noted)

PARAMETER		TEST CONDITIONS	MIN	TYP†	MAX	UNIT
t _{PLH}	Propagation delay time, low-to-high-level output	R _L = 50Ω, C _L = 10 pF, See Figure 5		1.7	3	ns
t _{PHL}	Propagation delay time, high-to-low-level output			1.7	3	ns
t _r	Differential output signal rise time			0.6	1.2	ns
t _f	Differential output signal fall time			0.6	1.2	ns
t _{sk(p)}	Pulse skew (t _{pHL} - t _{pLH})			750		ps
t _{sk(o)}	Channel-to-channel output skew‡			100		ps
t _{sk(pp)}	Part-to-part skew§				1	ns
t _{PZH}	Propagation delay time, high-impedance-to-high-level output	See Figure 6		6	10	ns
t _{PZL}	Propagation delay time, high-impedance-to-low-level output			6	10	ns
t _{PHZ}	Propagation delay time, high-level-to-high-impedance output			4	10	ns
t _{PLZ}	Propagation delay time, low-level-to-high-impedance output			5	10	ns

† All typical values are at 25°C and with a 3.3-V supply.

‡ t_{sk(o)} is the maximum delay time difference between drivers on the same device.

§ t_{sk(pp)} is the magnitude of the difference in propagation delay times between any specified terminals of two devices when both devices operate with the same supply voltages, at the same temperature, and have identical packages and test circuits.

receiver switching characteristics over recommended operating conditions (unless otherwise noted)

PARAMETER		TEST CONDITIONS	MIN	TYP†	MAX	UNIT
t _{PLH}	Propagation delay time, low-to-high-level output	C _L = 10 pF, See Figure 7		3.7	4.5	ns
t _{PHL}	Propagation delay time, high-to-low-level output			3.7	4.5	ns
t _{sk(p)}	Pulse skew (t _{pHL} - t _{pLH})			0.1		ns
t _{sk(o)}	Channel-to-channel output skew			0.2		ns
t _{sk(pp)}	Part-to-part skew‡				1	ns
t _r	Output signal rise time	C _L = 10 pF, See Figure 7		0.7	1.5	ns
t _f	Output signal fall time			0.9	1.5	ns
t _{PZH}	Propagation delay time, high-level-to-high-impedance output	See Figure 8		2.5		ns
t _{PZL}	Propagation delay time, low-level-to-low-impedance output			2.5		ns
t _{PHZ}	Propagation delay time, high-impedance-to-high-level output			7		ns
t _{PLZ}	Propagation delay time, low-impedance-to-high-level output			4		ns

† All typical values are at 25°C and with a 3.3-V supply.

‡ t_{sk(pp)} is the magnitude of the difference in propagation delay times between any specified terminals of two devices when both devices operate with the same supply voltages, at the same temperature, and have identical packages and test circuits.



PARAMETER MEASUREMENT INFORMATION

driver

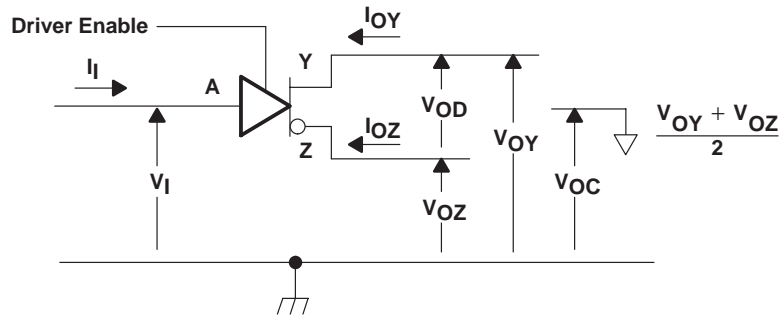
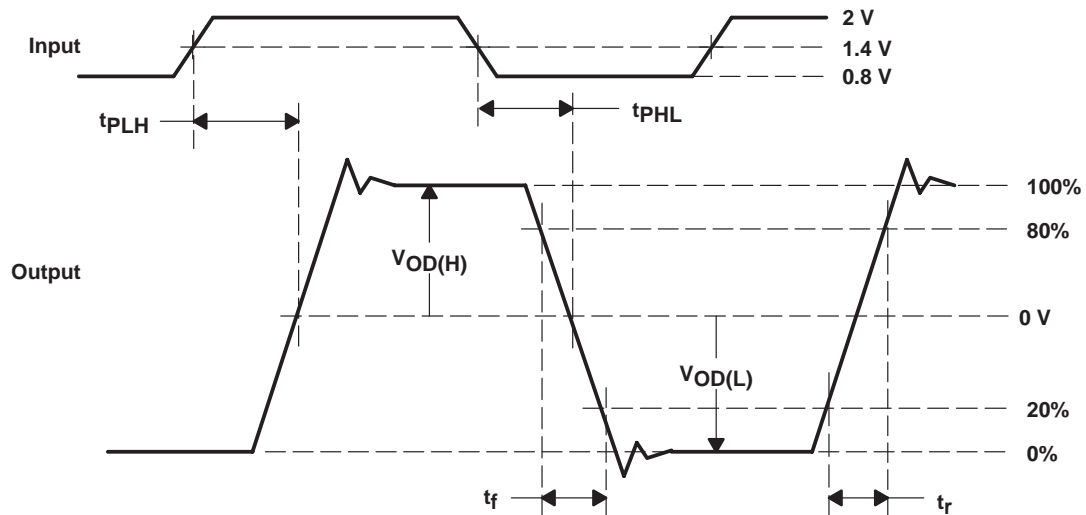
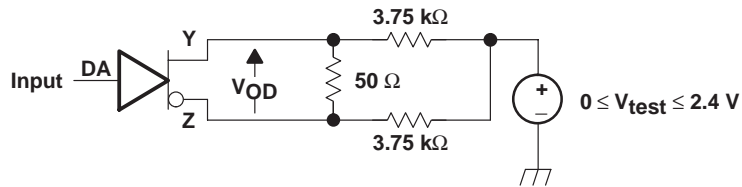

Figure 1. Driver Voltage and Current Definitions



NOTE A: All input pulses are supplied by a generator having the following characteristics: t_r or $t_f \leq 1$ ns, pulse repetition rate (PRR) = 50 Mpps, pulse width = 10 ± 0.2 ns. C_L includes instrumentation and fixture capacitance within 0,06 mm of the D.U.T.

Figure 2. Test Circuit, Timing, and Voltage Definitions for the Differential Output Signal

SN65LVDM050-Q1, SN65LVDM051-Q1 HIGH-SPEED DIFFERENTIAL LINE DRIVERS AND RECEIVERS

SGLS128A – JULY 2002 – REVISED APRIL 2008

PARAMETER MEASUREMENT INFORMATION

driver (continued)

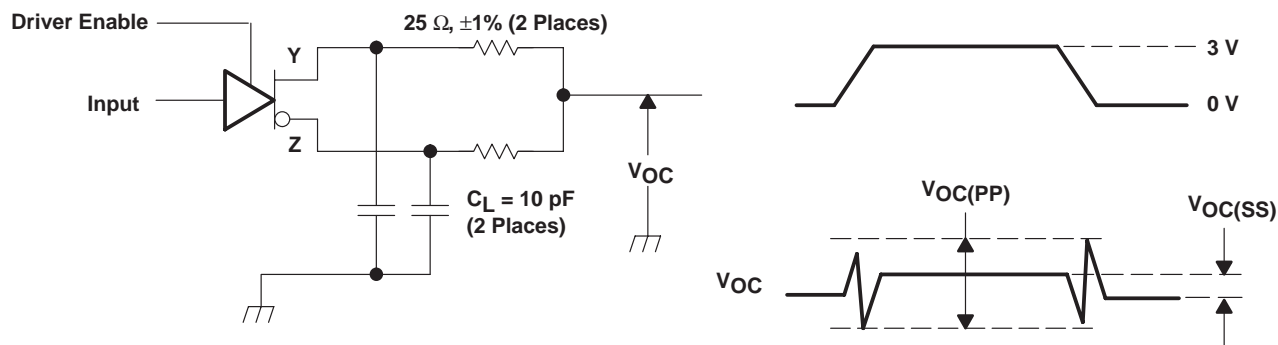

NOTE A: All input pulses are supplied by a generator having the following characteristics: t_r or $t_f \leq 1 \text{ ns}$, pulse repetition rate (PRR) = 50 Mpps, pulse width = $10 \pm 0.2 \text{ ns}$. C_L includes instrumentation and fixture capacitance within 0,06 mm of the D.U.T. The measurement of $V_{OC(PP)}$ is made on test equipment with a -3 dB bandwidth of at least 300 MHz.

Figure 3. Test Circuit and Definitions for the Driver Common-Mode Output Voltage

PARAMETER MEASUREMENT INFORMATION

receiver

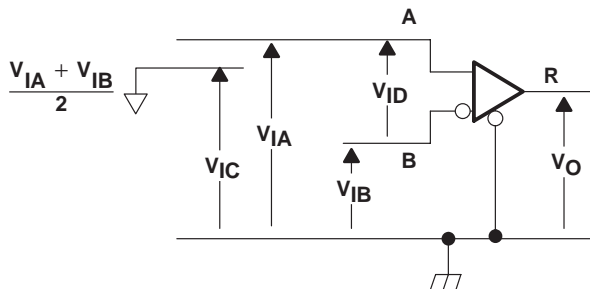

Figure 4. Receiver Voltage Definitions

Table 1. Receiver Minimum and Maximum Input Threshold Test Voltages

APPLIED VOLTAGES (V)		RESULTING DIFFERENTIAL INPUT VOLTAGE (mV)	RESULTING COMMON-MODE INPUT VOLTAGE (V)
V_{IA}	V_{IB}	V_{ID}	V_{IC}
1.225	1.175	50	1.2
1.175	1.225	-50	1.2
2.375	2.325	50	2.35
2.325	2.375	-50	2.35
0.05	0	50	0.05
0	0.05	-50	0.05
1.5	0.9	600	1.2
0.9	1.5	-600	1.2
2.4	1.8	600	2.1
1.8	2.4	-600	2.1
0.6	0	600	0.3
0	0.6	-600	0.3

SN65LVDM050-Q1, SN65LVDM051-Q1 HIGH-SPEED DIFFERENTIAL LINE DRIVERS AND RECEIVERS

SGLS128A – JULY 2002 – REVISED APRIL 2008

PARAMETER MEASUREMENT INFORMATION

driver

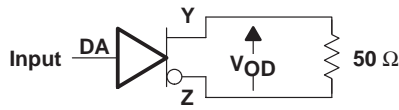
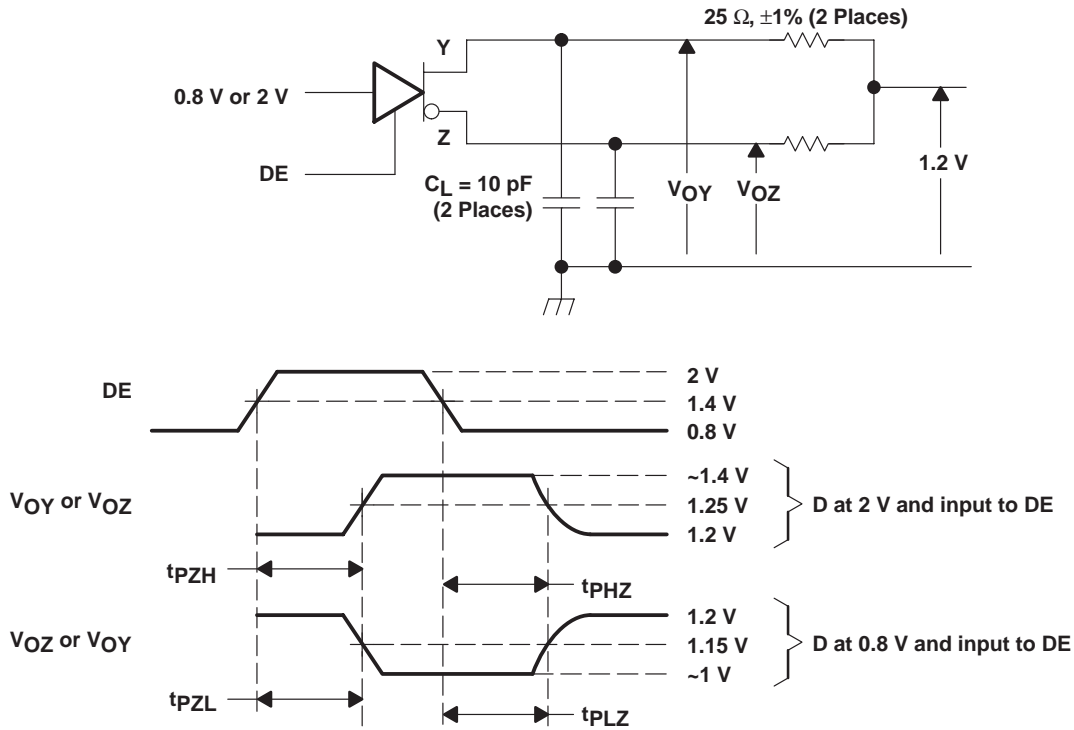

Figure 5. Timing Test Circuit



NOTE A: All input pulses are supplied by a generator having the following characteristics: t_r or $t_f \leq 1$ ns, pulse repetition rate (PRR) = 0.5 Mpps, pulse width = 500 ± 10 ns. C_L includes instrumentation and fixture capacitance within 0,06 mm of the D.U.T.

Figure 6. Enable and Disable Time Circuit and Definitions

PARAMETER MEASUREMENT INFORMATION

receiver

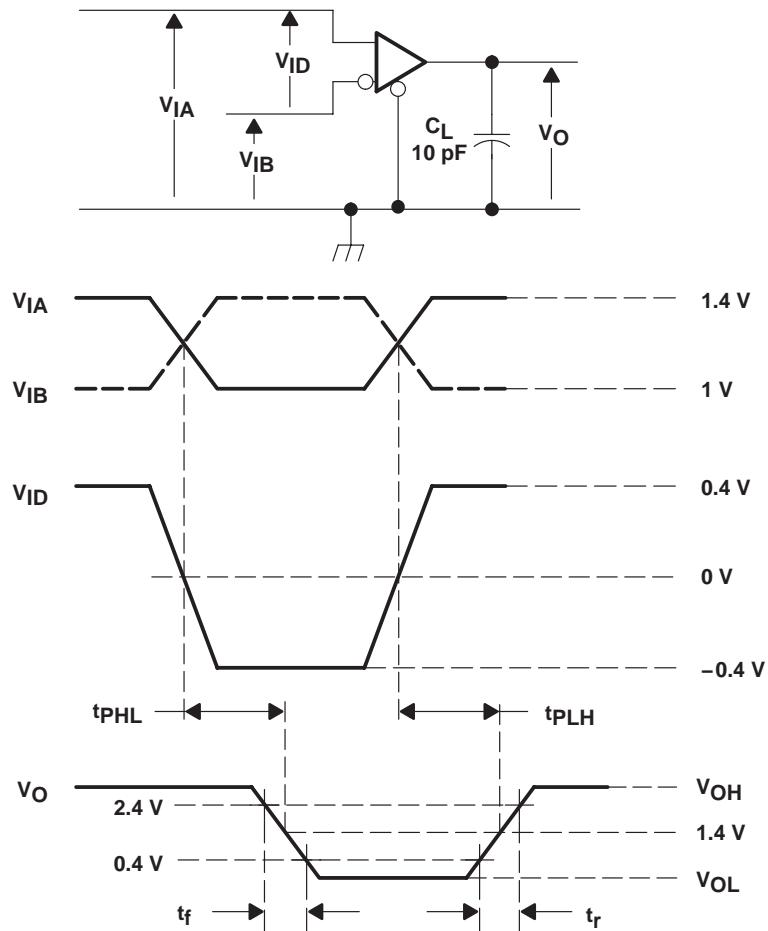

NOTE A: All input pulses are supplied by a generator having the following characteristics: t_r or $t_f \leq 1$ ns, pulse repetition rate (PRR) = 50 Mpps, pulse width = 10 ± 0.2 ns. C_L includes instrumentation and fixture capacitance within 0,06 mm of the D.U.T.

Figure 7. Timing Test Circuit and Waveforms

SN65LVDM050-Q1, SN65LVDM051-Q1 HIGH-SPEED DIFFERENTIAL LINE DRIVERS AND RECEIVERS

SGLS128A – JULY 2002 – REVISED APRIL 2008

PARAMETER MEASUREMENT INFORMATION

receiver (continued)

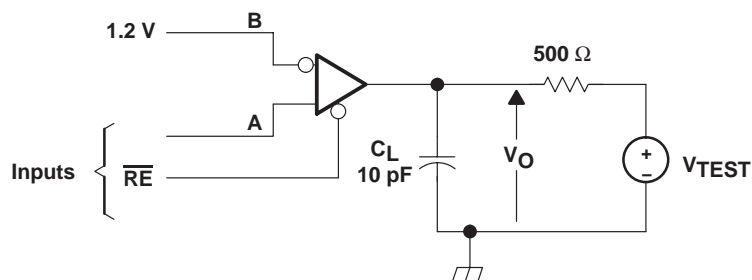

NOTE A: All input pulses are supplied by a generator having the following characteristics: t_r or $t_f \leq 1$ ns, pulse repetition rate (PRR) = 0.5 Mpps, pulse width = 500 ± 10 ns. C_L includes instrumentation and fixture capacitance within 0,06 mm of the D.U.T.

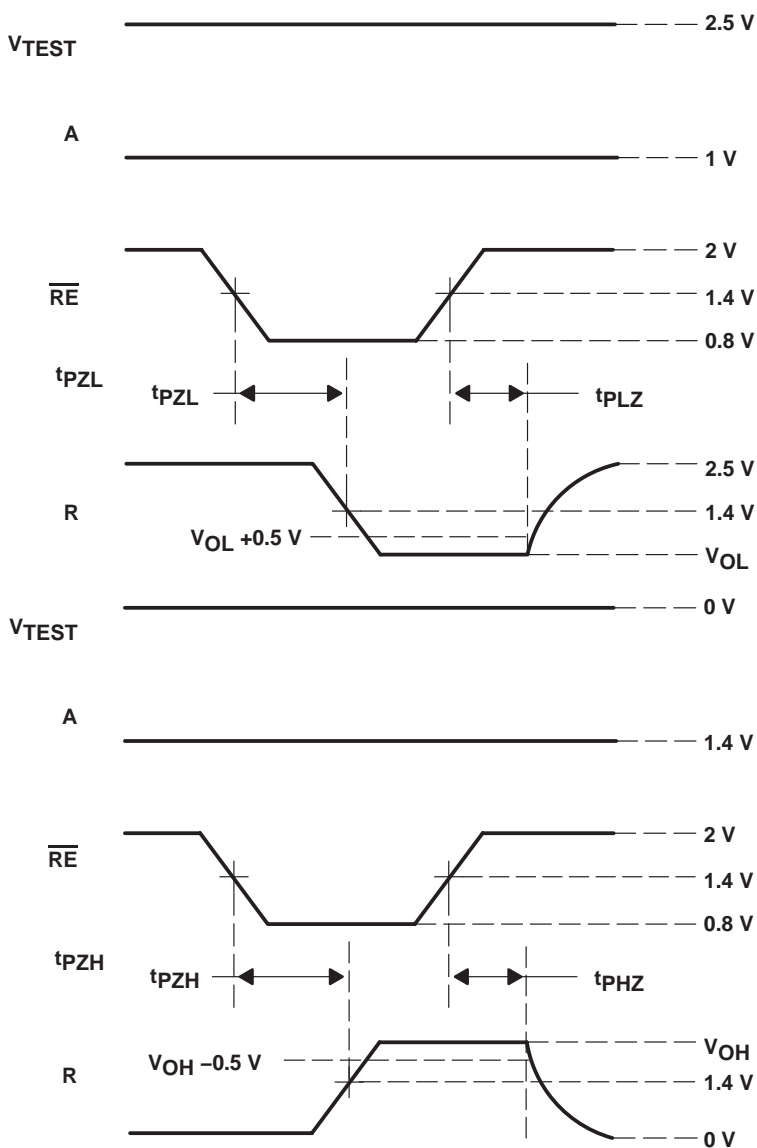

Figure 8. Enable/Disable Time Test Circuit and Waveforms

TYPICAL CHARACTERISTICS

COMMON-MODE INPUT VOLTAGE
vs
SUPPLY VOLTAGE

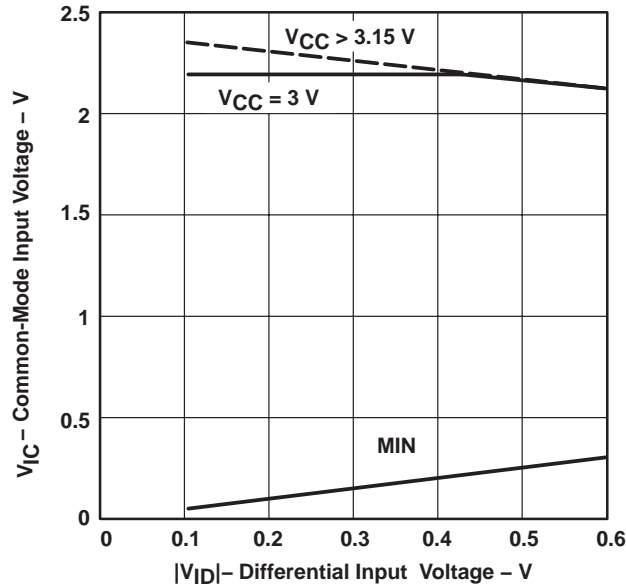

Figure 9

DRIVER
LOW-LEVEL OUTPUT VOLTAGE
vs
LOW-LEVEL OUTPUT CURRENT

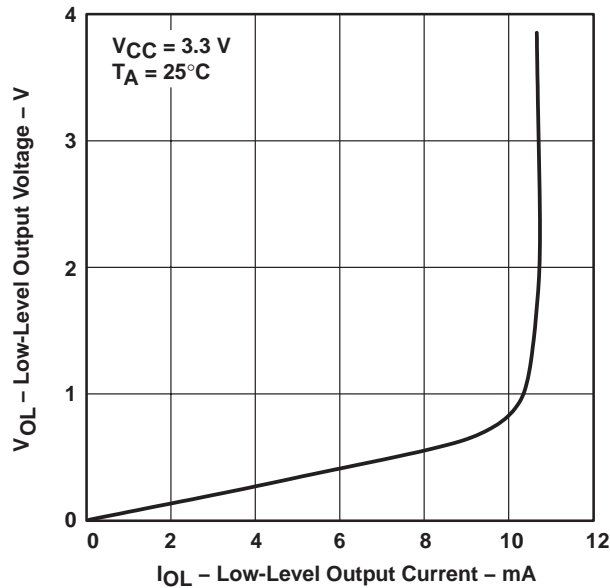

Figure 10

DRIVER
HIGH-LEVEL OUTPUT VOLTAGE
vs
HIGH-LEVEL OUTPUT CURRENT

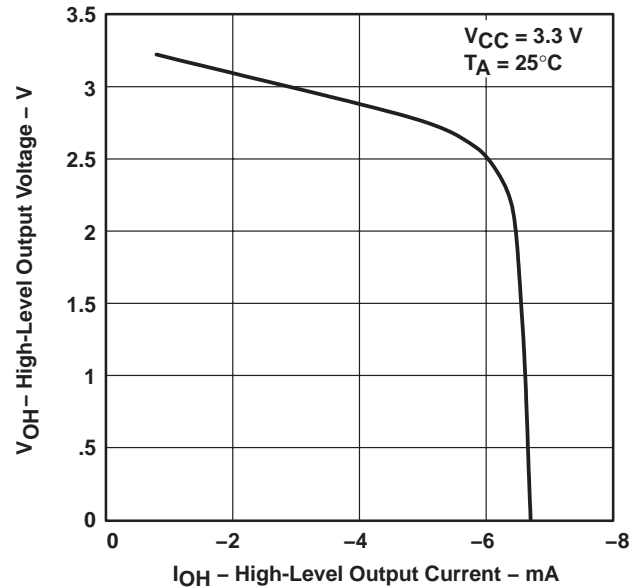
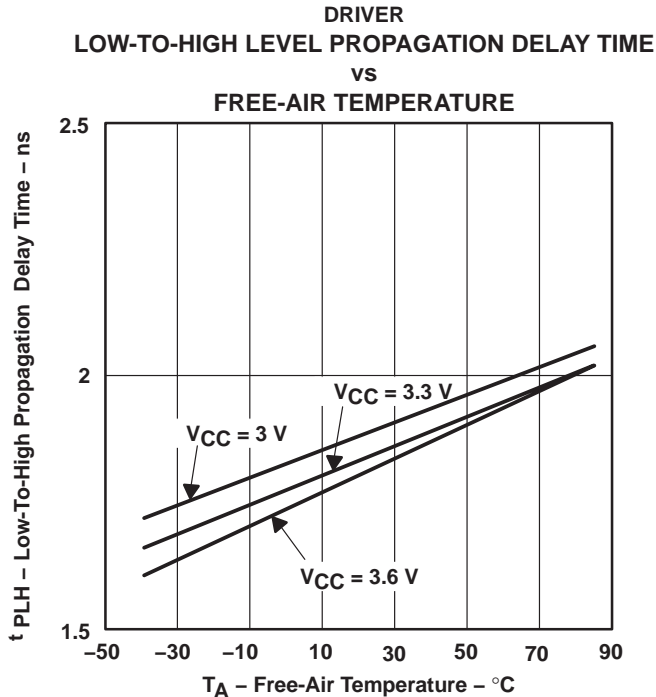
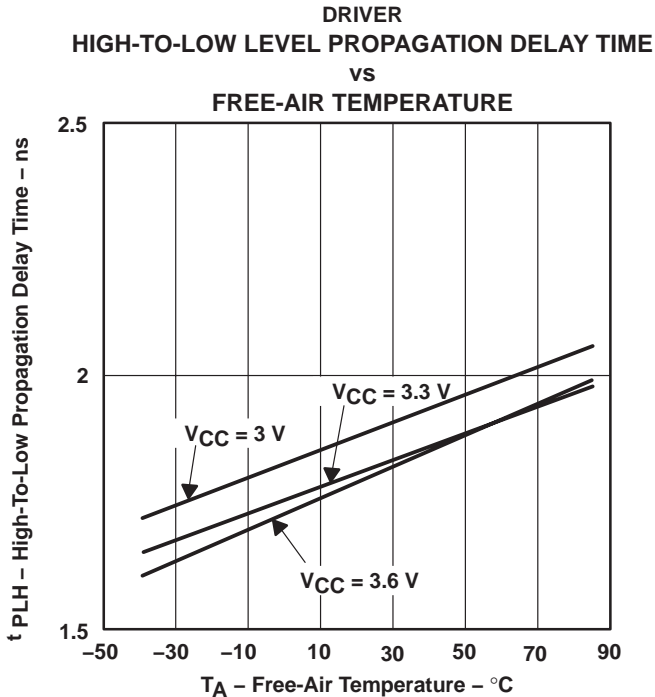
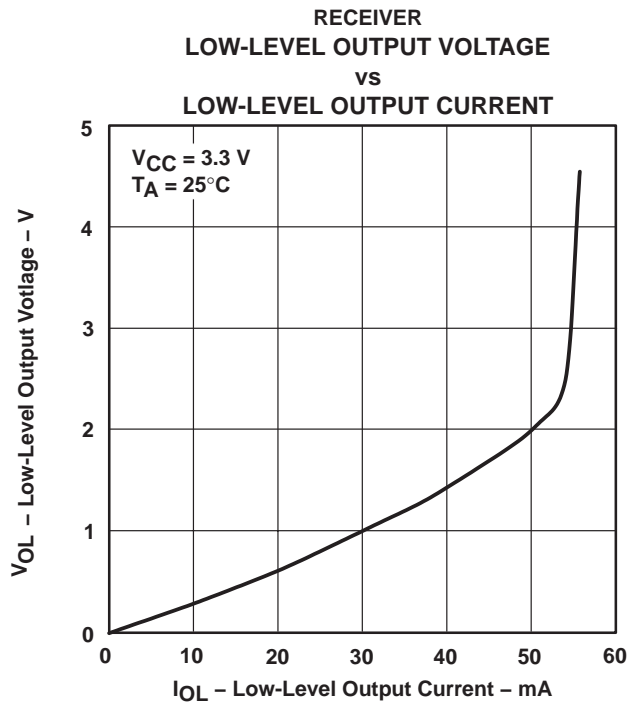
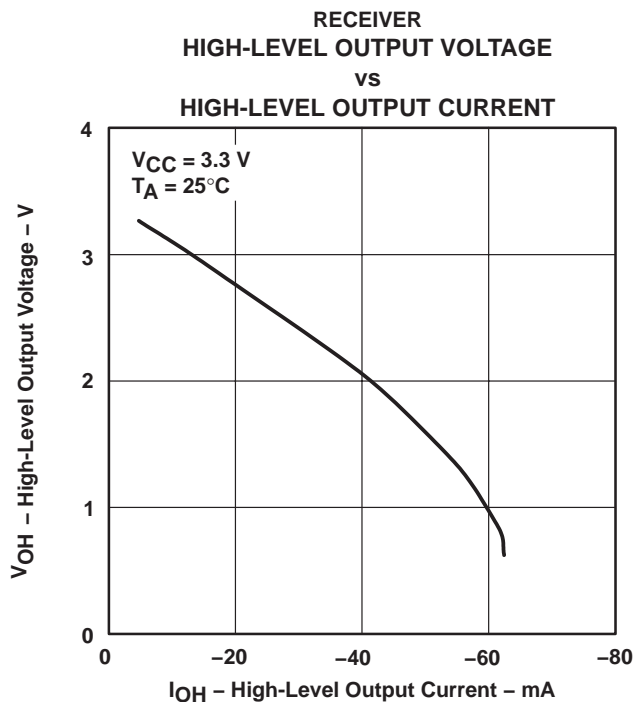

Figure 11

SN65LVDM050-Q1, SN65LVDM051-Q1 HIGH-SPEED DIFFERENTIAL LINE DRIVERS AND RECEIVERS

SGLS128A – JULY 2002 – REVISED APRIL 2008

TYPICAL CHARACTERISTICS



TYPICAL CHARACTERISTICS

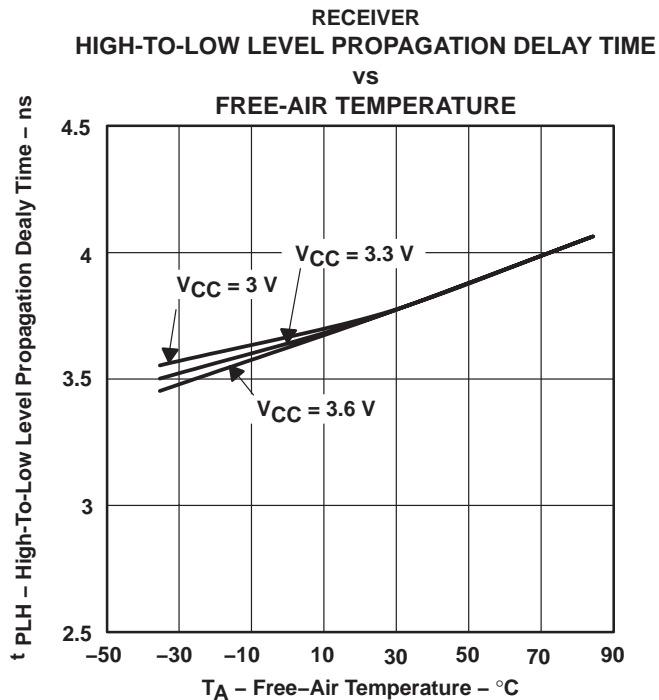

Figure 16

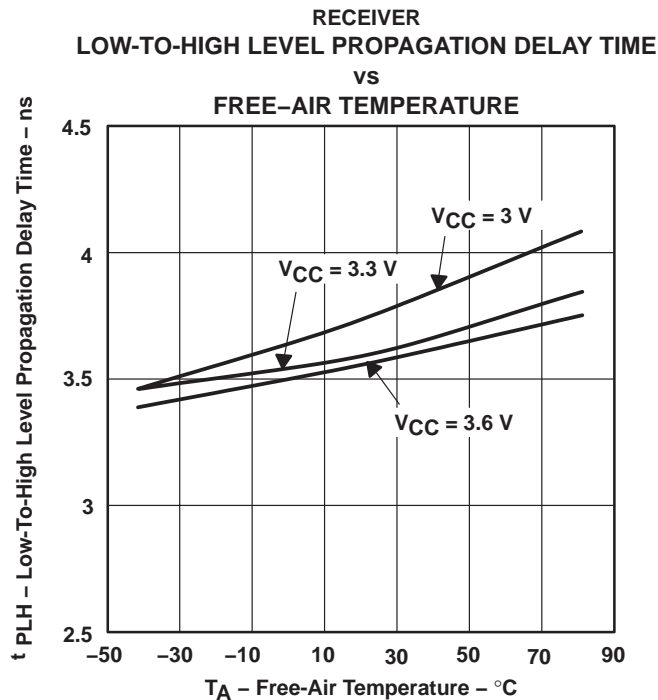

Figure 17

SN65LVDM050-Q1, SN65LVDM051-Q1 HIGH-SPEED DIFFERENTIAL LINE DRIVERS AND RECEIVERS

SGLS128A – JULY 2002 – REVISED APRIL 2008

APPLICATION INFORMATION

The devices are generally used as building blocks for high-speed point-to-point data transmission. Ground differences are less than 1 V with a low common-mode output and balanced interface for very low noise emissions. Devices can interoperate with RS-422, PECL, and IEEE-P1596. Drivers/receivers maintain ECL speeds without the power and dual supply requirements.

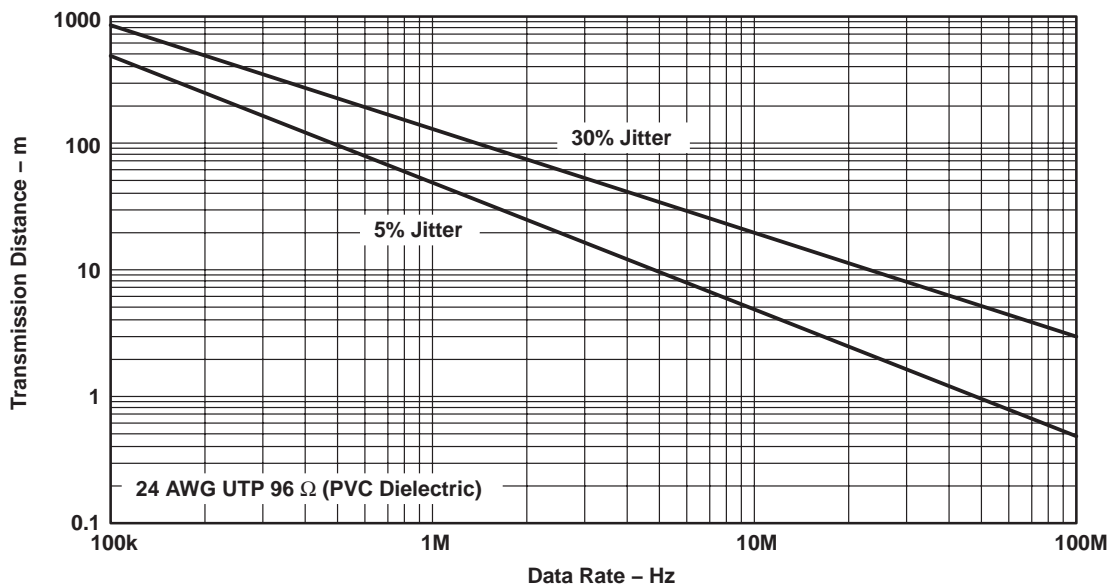

Figure 18. Data Transmission Distance Versus Rate

APPLICATION INFORMATION

fail safe

One of the most common problems with differential signaling applications is how the system responds when no differential voltage is present on the signal pair. The LVDS receiver is like most differential line receivers, in that its output logic state can be indeterminate when the differential input voltage is between -50 mV and 50 mV and within its recommended input common-mode voltage range. TI's LVDS receiver is different, however, in how it handles the open-input circuit situation.

Open-circuit means that there is little or no input current to the receiver from the data line itself. This could be when the driver is in a high-impedance state or the cable is disconnected. When this occurs, the LVDS receiver pulls each line of the signal pair to near V_{CC} through $300\text{-k}\Omega$ resistors as shown in Figure 18. The fail-safe feature uses an AND gate with input voltage thresholds at about 2.3 V to detect this condition and force the output to a high-level, regardless of the differential input voltage.

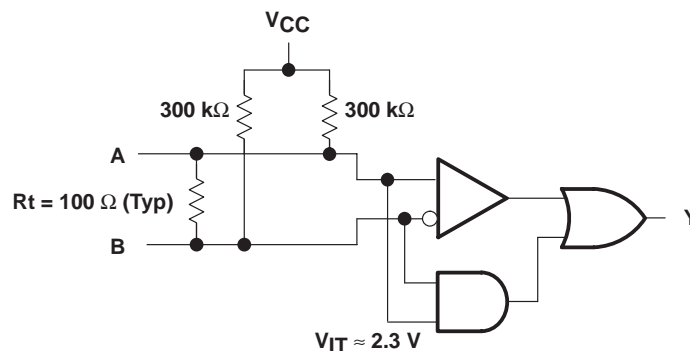

Figure 19. Open-Circuit Fail Safe of the LVDS Receiver

It is only under these conditions that the output of the receiver is valid with less than a 50-mV differential input voltage magnitude. The presence of the termination resistor, R_t , does not affect the fail-safe function as long as it is connected as shown in the figure. Other termination circuits may allow a dc current to ground that could defeat the pullup currents from the receiver and the fail-safe feature.

PACKAGING INFORMATION

Orderable Device	Status (1)	Package Type	Package Drawing	Pins	Package Qty	Eco Plan (2)	Lead finish/ Ball material (6)	MSL Peak Temp (3)	Op Temp (°C)	Device Marking (4/5)	Samples
SN65LVDM050QDG4Q1	ACTIVE	SOIC	D	16	40	RoHS & Green	NIPDAU	Level-1-260C-UNLIM	-40 to 125	LVDM050Q	Samples
SN65LVDM050QDQ1	ACTIVE	SOIC	D	16	40	RoHS & Green	NIPDAU	Level-1-260C-UNLIM	-40 to 125	LVDM050Q	Samples
SN65LVDM050QDRG4Q1	ACTIVE	SOIC	D	16	2500	RoHS & Green	NIPDAU	Level-1-260C-UNLIM	-40 to 125	LVDM050Q	Samples
SN65LVDM050QDRQ1	ACTIVE	SOIC	D	16	2500	RoHS & Green	NIPDAU	Level-1-260C-UNLIM	-40 to 125	LVDM050Q	Samples
SN65LVDM051QDQ1	ACTIVE	SOIC	D	16	40	RoHS & Green	NIPDAU	Level-1-260C-UNLIM	-40 to 125	LVDM051Q	Samples
SN65LVDM051QDRG4Q1	ACTIVE	SOIC	D	16	2500	RoHS & Green	NIPDAU	Level-1-260C-UNLIM	-40 to 125	LVDM051Q	Samples
SN65LVDM051QDRQ1	ACTIVE	SOIC	D	16	2500	RoHS & Green	NIPDAU	Level-1-260C-UNLIM	-40 to 125	LVDM051Q	Samples

(1) The marketing status values are defined as follows:

ACTIVE: Product device recommended for new designs.

LIFEBUY: TI has announced that the device will be discontinued, and a lifetime-buy period is in effect.

NRND: Not recommended for new designs. Device is in production to support existing customers, but TI does not recommend using this part in a new design.

PREVIEW: Device has been announced but is not in production. Samples may or may not be available.

OBSOLETE: TI has discontinued the production of the device.

(2) **RoHS:** TI defines "RoHS" to mean semiconductor products that are compliant with the current EU RoHS requirements for all 10 RoHS substances, including the requirement that RoHS substance do not exceed 0.1% by weight in homogeneous materials. Where designed to be soldered at high temperatures, "RoHS" products are suitable for use in specified lead-free processes. TI may reference these types of products as "Pb-Free".

RoHS Exempt: TI defines "RoHS Exempt" to mean products that contain lead but are compliant with EU RoHS pursuant to a specific EU RoHS exemption.

Green: TI defines "Green" to mean the content of Chlorine (Cl) and Bromine (Br) based flame retardants meet JS709B low halogen requirements of <=1000ppm threshold. Antimony trioxide based flame retardants must also meet the <=1000ppm threshold requirement.

(3) MSL, Peak Temp. - The Moisture Sensitivity Level rating according to the JEDEC industry standard classifications, and peak solder temperature.

(4) There may be additional marking, which relates to the logo, the lot trace code information, or the environmental category on the device.

(5) Multiple Device Markings will be inside parentheses. Only one Device Marking contained in parentheses and separated by a "~" will appear on a device. If a line is indented then it is a continuation of the previous line and the two combined represent the entire Device Marking for that device.

⁽⁶⁾ Lead finish/Ball material - Orderable Devices may have multiple material finish options. Finish options are separated by a vertical ruled line. Lead finish/Ball material values may wrap to two lines if the finish value exceeds the maximum column width.

Important Information and Disclaimer:The information provided on this page represents TI's knowledge and belief as of the date that it is provided. TI bases its knowledge and belief on information provided by third parties, and makes no representation or warranty as to the accuracy of such information. Efforts are underway to better integrate information from third parties. TI has taken and continues to take reasonable steps to provide representative and accurate information but may not have conducted destructive testing or chemical analysis on incoming materials and chemicals. TI and TI suppliers consider certain information to be proprietary, and thus CAS numbers and other limited information may not be available for release.

In no event shall TI's liability arising out of such information exceed the total purchase price of the TI part(s) at issue in this document sold by TI to Customer on an annual basis.

OTHER QUALIFIED VERSIONS OF SN65LVDM050-Q1, SN65LVDM051-Q1 :

- Catalog: [SN65LVDM050](#), [SN65LVDM051](#)

NOTE: Qualified Version Definitions:

- Catalog - TI's standard catalog product

TAPE AND REEL INFORMATION

QUADRANT ASSIGNMENTS FOR PIN 1 ORIENTATION IN TAPE



*All dimensions are nominal

Device	Package Type	Package Drawing	Pins	SPQ	Reel Diameter (mm)	Reel Width W1 (mm)	A0 (mm)	B0 (mm)	K0 (mm)	P1 (mm)	W (mm)	Pin1 Quadrant
SN65LVDM050QDRQ1	SOIC	D	16	2500	330.0	16.4	6.5	10.3	2.1	8.0	16.0	Q1
SN65LVDM051QDRG4Q1	SOIC	D	16	2500	330.0	16.4	6.5	10.3	2.1	8.0	16.0	Q1
SN65LVDM051QDRQ1	SOIC	D	16	2500	330.0	16.4	6.5	10.3	2.1	8.0	16.0	Q1

TAPE AND REEL BOX DIMENSIONS

*All dimensions are nominal

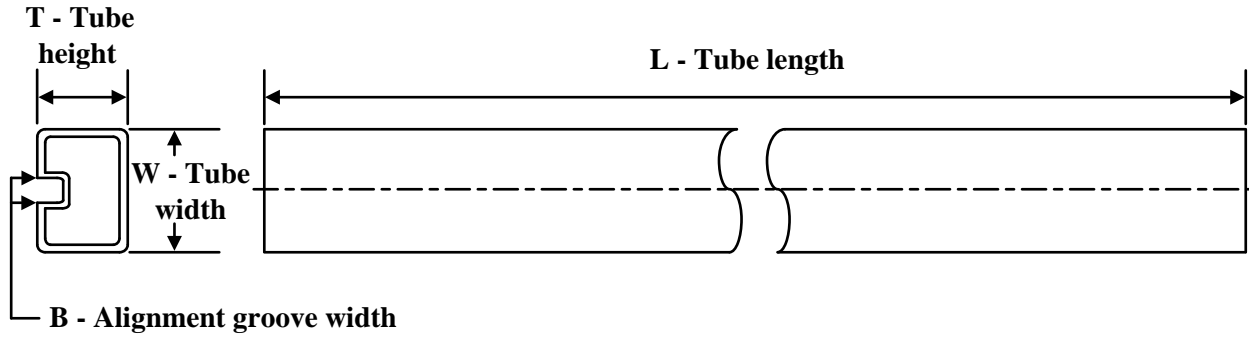
Device	Package Type	Package Drawing	Pins	SPQ	Length (mm)	Width (mm)	Height (mm)
SN65LVDM050QDRQ1	SOIC	D	16	2500	350.0	350.0	43.0
SN65LVDM051QDRG4Q1	SOIC	D	16	2500	350.0	350.0	43.0
SN65LVDM051QDRQ1	SOIC	D	16	2500	350.0	350.0	43.0

TUBE

*All dimensions are nominal

Device	Package Name	Package Type	Pins	SPQ	L (mm)	W (mm)	T (μm)	B (mm)
SN65LVDM050QDG4Q1	D	SOIC	16	40	505.46	6.76	3810	4
SN65LVDM050QDQ1	D	SOIC	16	40	505.46	6.76	3810	4
SN65LVDM051QDQ1	D	SOIC	16	40	505.46	6.76	3810	4

D (R-PDSO-G16)

PLASTIC SMALL OUTLINE



- NOTES:
- A. All linear dimensions are in inches (millimeters).
 - B. This drawing is subject to change without notice.
 - C. Body length does not include mold flash, protrusions, or gate burrs. Mold flash, protrusions, or gate burrs shall not exceed 0.006 (0,15) each side.
 - D. Body width does not include interlead flash. Interlead flash shall not exceed 0.017 (0,43) each side.
 - E. Reference JEDEC MS-012 variation AC.

IMPORTANT NOTICE AND DISCLAIMER

TI PROVIDES TECHNICAL AND RELIABILITY DATA (INCLUDING DATA SHEETS), DESIGN RESOURCES (INCLUDING REFERENCE DESIGNS), APPLICATION OR OTHER DESIGN ADVICE, WEB TOOLS, SAFETY INFORMATION, AND OTHER RESOURCES "AS IS" AND WITH ALL FAULTS, AND DISCLAIMS ALL WARRANTIES, EXPRESS AND IMPLIED, INCLUDING WITHOUT LIMITATION ANY IMPLIED WARRANTIES OF MERCHANTABILITY, FITNESS FOR A PARTICULAR PURPOSE OR NON-INFRINGEMENT OF THIRD PARTY INTELLECTUAL PROPERTY RIGHTS.

These resources are intended for skilled developers designing with TI products. You are solely responsible for (1) selecting the appropriate TI products for your application, (2) designing, validating and testing your application, and (3) ensuring your application meets applicable standards, and any other safety, security, regulatory or other requirements.

These resources are subject to change without notice. TI grants you permission to use these resources only for development of an application that uses the TI products described in the resource. Other reproduction and display of these resources is prohibited. No license is granted to any other TI intellectual property right or to any third party intellectual property right. TI disclaims responsibility for, and you will fully indemnify TI and its representatives against, any claims, damages, costs, losses, and liabilities arising out of your use of these resources.

TI's products are provided subject to [TI's Terms of Sale](#) or other applicable terms available either on [ti.com](https://www.ti.com) or provided in conjunction with such TI products. TI's provision of these resources does not expand or otherwise alter TI's applicable warranties or warranty disclaimers for TI products.

TI objects to and rejects any additional or different terms you may have proposed.

Mailing Address: Texas Instruments, Post Office Box 655303, Dallas, Texas 75265
Copyright © 2024, Texas Instruments Incorporated

Looking for pricing, stock, or lifecycle information?

Click below to explore more details on WIN SOURCE:

 [View SN65LVDM051QDG4Q1 on WIN SOURCE](#)

 [Texas Instruments](#) Information

Optimize Your Supply Chain with WIN SOURCE Solutions

-  Global Sourcing Solution
-  Obsolete Management
-  Cost Control Management
-  Shortage Management
-  Alternative Solution
-  Excess Inventory Management