



**THE DATASHEET OF
MAX4805ACTJ+**



Octal High-Voltage-Protected, Low-Power, Low-Noise Operational Amplifiers

General Description

The MAX4805/MAX4805A are octal high-voltage-protected operational amplifiers. These devices are a fully integrated, very compact solution for in-probe amplification of echo signals coming from transducers in an ultrasound system. The use of in-probe buffering improves system signal-to-noise ratio (SNR) for transducers featuring high-output impedance. This results in greater penetration depth and sensitivity. The MAX4805/MAX4805A can be adopted in ultrasound probes without any change in the system (scanner machine). Typical applications include high-impedance piezoelectric transducers (PZT) and capacitive micromachined ultrasonic transducers (CMUT) in-probe buffering and amplification. The MAX4805 is optimized for PZT applications, and the MAX4805A is optimized for CMUT applications.

The MAX4805/MAX4805A feature eight operational amplifiers configured in a noninverting configuration. The small-signal output impedance of these operational amplifiers is 65Ω (typ) for matching the typical cable impedance. The low-noise amplifier features 44MHz (typ) -3dB bandwidth and very low voltage and current noise, ensuring excellent noise figure. The output signals of these operational amplifiers are limited with diodes in an antiparallel configuration to GND.

The MAX4805/MAX4805A provide HV protection for inputs and outputs of the operational amplifiers. The operational amplifiers inputs are protected by an external HV capacitor. An integrated automatic high-voltage switch protects the output of the amplifier from HV bursts. Transmitted bursts reach the transducer through a pair of integrated, antiparallel diodes. Each channel is able to sustain transmission burst up to ≤ 100V. The high-voltage (HV) protection is automatically activated as soon as the TX voltage is greater than ±2.7V (typ); no dedicated TX/RX signal is required.

The MAX4805 and the MAX4805A differ in terms of input-current noise, input impedance, and voltage gain. Depending on the equivalent transducer source impedance, either the MAX4805 or the MAX4805A can be used to optimize a better noise figure.

The MAX4805/MAX4805A are available in the 32-pin TQFN package. All devices are specified for the commercial 0°C to +70°C temperature range.

Features

- ◆ High Density/8 Channels Per Package
- ◆ I/O Protection for TX Burst Up to ±100V
- ◆ Very Fast Recovery Time After TX Burst 1.5μs (typ)
- ◆ OVP for Signals Greater Than ±2.7V (typ)
- ◆ Extremely Low Power Dissipation 8mW/ch (typ)
- ◆ 65Ω (typ) Low-Signal Output Impedance
- ◆ 44MHz -3dB Bandwidth (typ)
- ◆ Voltage Gain 6dB (MAX4805) (typ), 9dB (MAX4805A) (typ)
- ◆ Low Voltage Noise 2.2nV/√Hz (typ) (MAX4805)
- ◆ Low Voltage Noise 2.2nV/√Hz (typ) (MAX4805A)
- ◆ Low Current Noise 2.0pA/√Hz (typ) (MAX4805)
- ◆ Low Current Noise 1.7pA/√Hz (typ) (MAX4805A)
- ◆ Ultra-Small (5mm x 5mm), 32-Pin TQFN Package

Applications

Ultrasound Medical Imaging, CMUT Probes
 Ultrasound Medical Imaging, PZT HF Probes
 Ultrasound Imaging, PZT NDT Probes

Ordering Information/Selector Guide

PART	VOLTAGE NOISE (nV/√Hz)	CURRENT NOISE (pA/√Hz)	VOLTAGE GAIN (dB)	APPLICATIONS	PIN-PACKAGE
MAX4805CTJ+	2.2	2.0	5.7	PZT	32 TQFN-EP*
MAX4805ACTJ+	2.2	1.7	8.7	PZT, CMUT	32 TQFN-EP*

Note: All devices are specified over the 0°C to +70°C operating temperature range.

*EP = Exposed pad.

+Denotes a lead(Pb)-free/RoHS-compliant package.

For pricing, delivery, and ordering information, please contact Maxim Direct at 1-888-629-4642, or visit Maxim's website at www.maximintegrated.com.

MAX4805/MAX4805A

Octal High-Voltage-Protected, Low-Power, Low-Noise Operational Amplifiers

ABSOLUTE MAXIMUM RATINGS

(All voltages referenced to GND.)

V _{TX} , V _{OUT}	(V _{GSUB} - 0.3V) to +100V	Junction-to-Ambient Thermal Resistance	29°C/W
V _{TX} - V _{OUT}	-0.5V to +0.5V	θ _{JA} (Note 1).....	29°C/W
V _{IN}	-0.5V to +0.5V	Junction-to-Case Thermal Resistance
V _{CC1} , V _{CC2}	-0.3V to +6V	θ _{JC} (Note 1).....	2°C/W
V _{EE1} , V _{EE2}	-6V to +0.3V	Operating Temperature Range.....	0°C to +70°C
G _{SUB}	-100V to +0.3V	Storage Temperature Range.....	-65°C to +150°C
EN.....	-0.3V to +6V	Junction Temperature.....	+150°C
Continuous Power Dissipation (T _A = +70°C)		Lead Temperature (soldering, 10s).....	+300°C
32-Pin TQFN (derate 34.5mW/°C above +70°C).....	2758.6mW	Soldering Temperature (reflow).....	+260°C

Note 1: Package thermal resistances were obtained using the method described in JEDEC specification JESD51-7, using a four-layer board. For detailed information on package thermal considerations, refer to www.maxim-ic.com/thermal-tutorial.

Stresses beyond those listed under "Absolute Maximum Ratings" may cause permanent damage to the device. These are stress ratings only, and functional operation of the device at these or any other conditions beyond those indicated in the operational sections of the specifications is not implied. Exposure to absolute maximum rating conditions for extended periods may affect device reliability.

DC ELECTRICAL CHARACTERISTICS

(V_{CC1} = -V_{EE1} = +2V ±2.5%, T_A = 0°C to +70°C, unless otherwise noted. Typical values are at V_{CC1} = -V_{EE1} = +2V, V_{CC2} = -V_{EE2} = +5V, T_A = +25°C.) (Note 2)

PARAMETER	SYMBOL	CONDITIONS	MIN	TYP	MAX	UNITS
Supply Voltage 1	V _{CC1}	V _{CC1} = -V _{EE1}	1.95	2	5	V
Supply Voltage 2	V _{CC2}	V _{CC2} = -V _{EE2}	4.9	5	5.1	V
Supply Current from V _{CC1} and V _{EE1}	I _{CC1}	MAX4805 Current consumption from V _{CC1} and V _{EE1} (per channel), V _{CC1} = -V _{EE1} = +2V, V _{CC2} = -V _{EE2} = +5V		2.1	3.2	mA
		MAX4805A Current consumption from V _{CC1} and V _{EE1} (per channel), V _{CC1} = -V _{EE1} = +2V, V _{CC2} = -V _{EE2} = +5V		1.9	3.0	
Supply Current from V _{CC2} and V _{EE2}	I _{CC2}	V _{CC1} = -V _{EE1} = +2V, V _{CC2} = -V _{EE2} = +5V (per channel) (in reception)		25	50	μA
Substrate Supply Current	I _{GSUB}	V _{CC1} = -V _{EE1} = +2V, V _{GSUB} = -100V, V _{OUT} = square pulses with ±60V amplitude, f = 5MHz, duty cycle = 2%, PRF = 20kHz, C _{EXT} = 100pF (per channel) (in transmission)		10		μA
Power Dissipation in Reception	PD1	MAX4805 V _{CC1} = -V _{EE1} = +2V, V _{CC2} = -V _{EE2} = +5V (per channel) (in reception) (no signal applied)		8.4	13.2	mW
		MAX4805A V _{CC1} = -V _{EE1} = +2V, V _{CC2} = -V _{EE2} = +5V (per channel) (in reception) (no signal applied)			12.2	

MAX4805/MAX4805A

Octal High-Voltage-Protected, Low-Power, Low-Noise Operational Amplifiers

DC ELECTRICAL CHARACTERISTICS (continued)

($V_{CC1} = -V_{EE1} = +2V \pm 2.5\%$, $T_A = 0^\circ\text{C}$ to $+70^\circ\text{C}$, unless otherwise noted. Typical values are at $V_{CC1} = -V_{EE1} = +2V$, $V_{CC2} = -V_{EE2} = +5V$, $T_A = +25^\circ\text{C}$.) (Note 2)

PARAMETER	SYMBOL	CONDITIONS		MIN	TYP	MAX	UNITS
Power Dissipation in Transmission	PD2	$V_{CC1} = -V_{EE1} = +2V$, $V_{GSUB} = -100V$, $V_{OUT_}$ = square pulses with $\pm 60V$ amplitude, $f = 5\text{MHz}$, duty cycle = 2%, $\text{PRF} = 20\text{kHz}$, C_{EXT1} (between TX_ and IN_) = 100pF , C_{EXT2} (between TX_ and GND) = 100pF (per channel) (in transmission)			20		mW
Total Supply Current in Low-Power Mode	I_{OFF}	EN = GND			0.1	1	μA
DC Output Bias	V_{OFF}	TX_ and IN_ unconnected	MAX4805	-20	-3	+20	mV
			MAX4805A	-50	-10	+50	
Small-Signal Output Resistance	R_{OUT}	$V_{OUT_} = 50\text{mV}$	$T_A = +25^\circ\text{C}$	48	65	101	Ω
			$T_A = T_{MIN}$ to T_{MAX}	35		140	
DC Output	V_{OUT}	$R_L = 100\Omega$ ($T_A = +25^\circ\text{C}$) (Note 3)		400			mV _{P-P}
Maximum Output Range	V_{OUT_P-P}	$R_L = 100\Omega$, THD < 5% (peak to peak), $f = 5\text{MHz}$			500		mV _{P-P}
Voltage Gain	A_V	$R_L = 10\text{k}\Omega$ (MAX4805)		5.1	5.7	6.1	dB
		$R_L = 10\text{k}\Omega$ (MAX4805A)		7.8	8.7	9.2	dB
Transmission Diode On-Resistance	R_{ON}	$I = 1\text{A}$			1.5		Ω
Transmission Drop	TXDROD	$I = 1\text{mA}$		400	600	750	mV
Positive OVP Thresholds	V_{OVP+}	Output Impedance $\geq 1\text{k}\Omega$, $V_{CC2} = -V_{EE2} = +5V$	$T_A = +25^\circ\text{C}$	1.5	2.7	3.8	V
			$T_A = T_{MIN}$ to T_{MAX}	1.0		4.0	
Negative OVP Threshold	V_{OVP-}	Output Impedance $\geq 1\text{k}\Omega$, $V_{CC2} = -V_{EE2} = +5V$	$T_A = +25^\circ\text{C}$	-4.1	-2.9	-1.5	V
			$T_A = T_{MIN}$ to T_{MAX}	-4.5		-1.0	
Input Resistance	R_{IN}	IN_ input (MAX4805)		2.7	4	5.4	$\text{k}\Omega$
		IN_ input (MAX4805A)		15.5	24	33.0	$\text{k}\Omega$
LOGIC INPUT (EN)							
Low-Level Input Voltage	V_{IL}					$0.25 \times V_{CC1}$	V
High-Level Input Voltage	V_{IH}			$0.75 \times V_{CC1}$			V
Logic-Input Leakage	I_{LEAK}			-1		+1	μA

MAX4805/MAX4805A

Octal High-Voltage-Protected, Low-Power, Low-Noise Operational Amplifiers

AC ELECTRICAL CHARACTERISTICS

($V_{CC1} = -V_{EE1} = +2V \pm 2.5\%$, $T_A = 0^\circ\text{C}$ to $+70^\circ\text{C}$, unless otherwise noted. Typical values are at $V_{CC1} = -V_{EE1} = +2V$, $V_{CC2} = -V_{EE2} = +5V$, $T_A = +25^\circ\text{C}$.) (Note 2)

PARAMETER	SYMBOL	CONDITIONS	MIN	TYP	MAX	UNITS
Total Harmonic Distortion	THD	$f = 5\text{MHz}$, $R_L = 1\text{k}\Omega$, $V_{IN} = 20\text{mV}_{P-P}$		-50		dB
Bandwidth	BW	-3dB bandwidth, $R_L = 75\Omega$, $C_L = 20\text{pF}$, $V_{IN} = 20\text{mV}_{P-P}$		44		MHz
Input-Voltage Noise on IN_-	E_{NOISE}	$f = 5\text{MHz}$ (MAX4805)		2.2		$\text{nV}/\sqrt{\text{Hz}}$
		$f = 12.5\text{MHz}$ (MAX4805A)		2.2		
Input-Current Noise on IN_-	I_{NOISE}	$f = 5\text{MHz}$ (MAX4805)		2.0		$\text{pA}/\sqrt{\text{Hz}}$
		$f = 12.5\text{MHz}$ (MAX4805A)		1.7		
Output Impedance	Z_{OUT}	$f = 5\text{MHz}$		70		Ω
Input Impedance	Z_{IN}	$f = 5\text{MHz}$	MAX4805	3.8		$\text{k}\Omega$
			MAX4805A	9.1		
Equivalent Input Capacitance	C_{IN}			3.5		pF
Channel Crosstalk	CT	$f = 5\text{MHz}$, $V_{OUT} = 0.5\text{V}_{P-P}$ (adjacent channels), $R_{IN} = 1\text{k}\Omega$		-40		dB
Slew Rate	SR	$V_{IN_-} = \pm 200\text{mV}$ square wave, $V_{OUT_-} = \pm 100\text{mV}$, $R_L = 1\text{k}\Omega$ (MAX4805)		≤ 20		$\text{V}/\mu\text{s}$
		$V_{IN_-} = \pm 150\text{mV}$ square wave, $V_{OUT_-} = \pm 100\text{mV}$, $R_L = 1\text{k}\Omega$ (MAX4805A)		≤ 25		
Power-Supply Rejection Ratio	PSRR- V_{CC1}	$f = 5\text{MHz}$, 1mV_{P-P}		-43		dB
	PSRR- V_{EE1}	$f = 5\text{MHz}$, 1mV_{P-P}		-45		
	PSRR- G_{SUB}	$f = 5\text{MHz}$, 1mV_{P-P}		-43		
Signal-to-Noise Ratio	SNR	$C_{EXT} = 100\text{pF}$ (see Figure 1)		170		dBV
Recovery Time After a Transmitted Pulse	t_R	$V_{CC2} = -V_{EE2} = +5\text{V}$, $\pm 5\text{V} \leq \text{RTZ Pulse} \leq \pm 60\text{V}$ (see Figure 2)		1.5		μs
Enable Time	t_{EN}	EN signal high to normal operation			5	μs
Disable Time	t_{DIS}	EN signal low to low-power mode			1.5	μs

Note 2: All specifications are 100% tested at $T_A = +25^\circ\text{C}$, unless otherwise noted. Limits over temperature are guaranteed by design.

Note 3: Guaranteed by design. Not production tested.

MAX4805/MAX4805A

Octal High-Voltage-Protected, Low-Power, Low-Noise Operational Amplifiers

Test Circuits

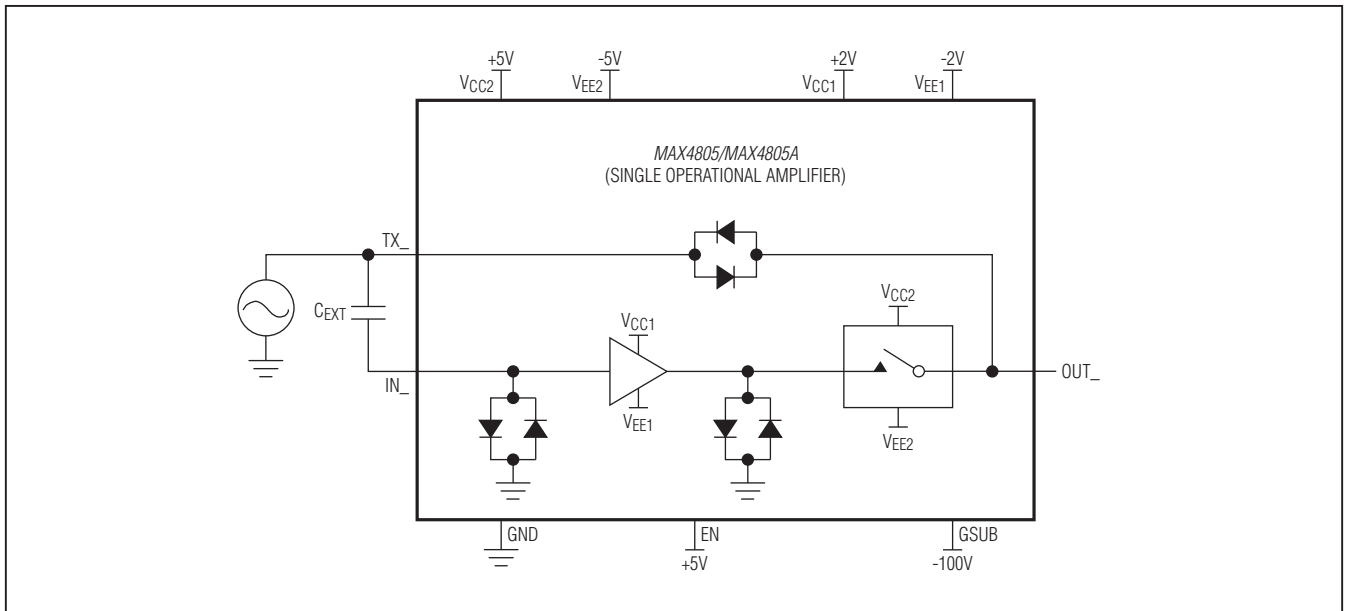

Figure 1. SNR Test Circuit

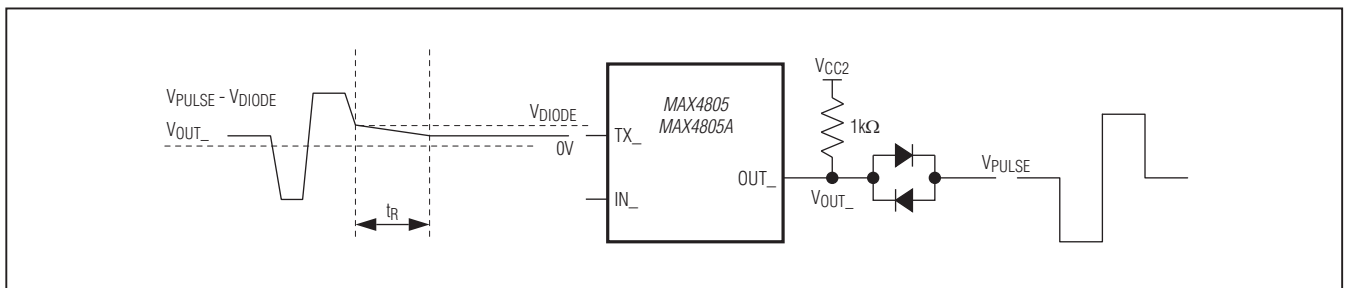

Figure 2. Recovery Time Test Circuit

MAX4805/MAX4805A

Octal High-Voltage-Protected, Low-Power, Low-Noise Operational Amplifiers

Typical Operating Characteristics

($V_{CC1} = -V_{EE1} = +2V$, $V_{CC2} = -V_{EE2} = +5V$, $T_A = +25^\circ C$, unless otherwise noted.)

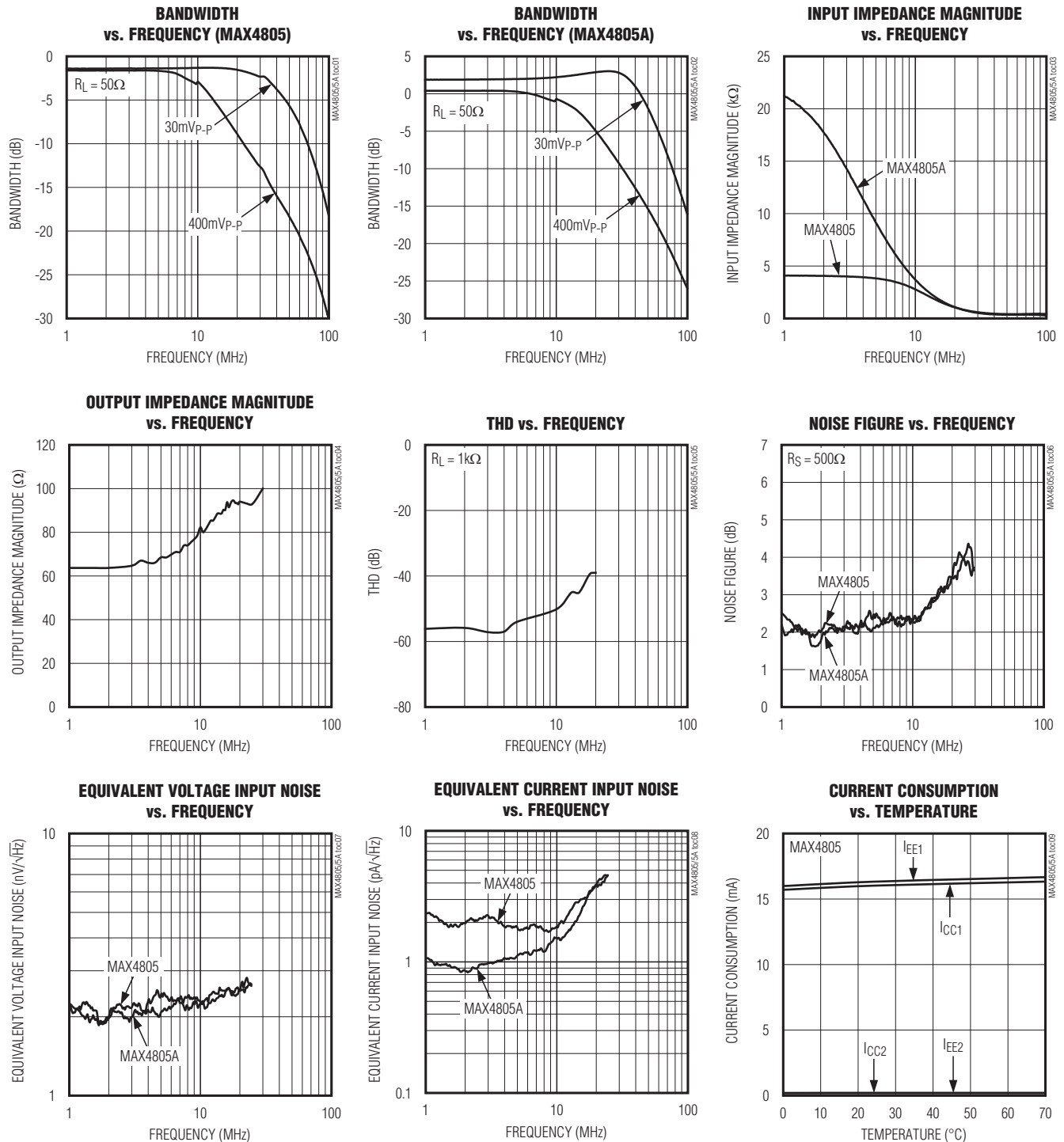

MAX4805/MAX4805A

Octal High-Voltage-Protected, Low-Power, Low-Noise Operational Amplifiers

Typical Operating Characteristics (continued)

($V_{CC1} = -V_{EE1} = +2V$, $V_{CC2} = -V_{EE2} = +5V$, $T_A = +25^\circ C$, unless otherwise noted.)

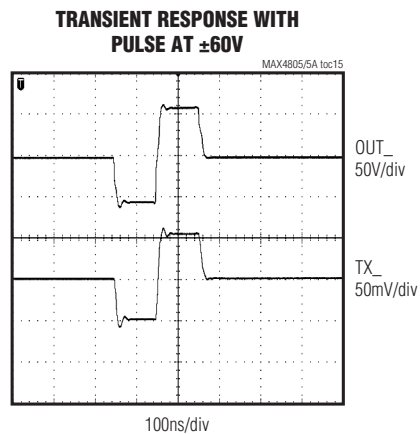
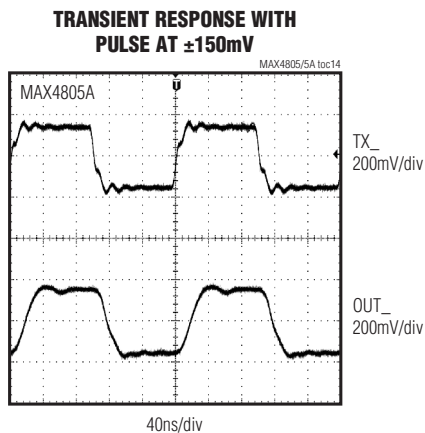
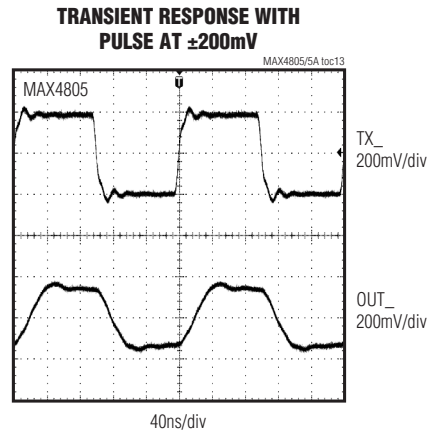
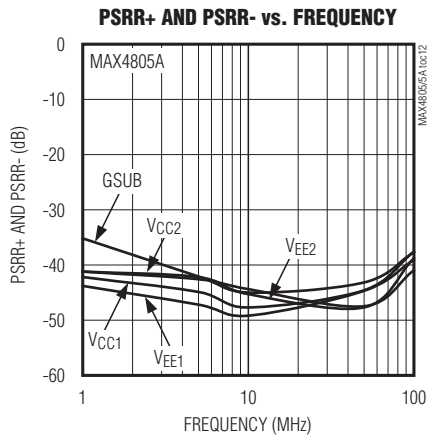
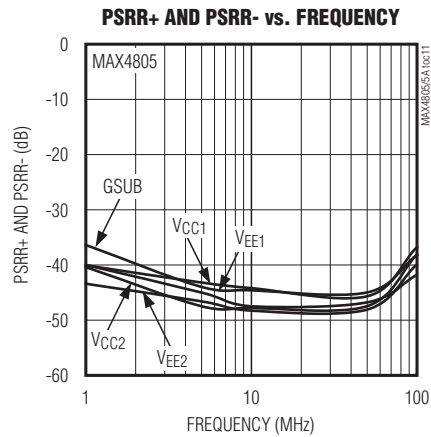
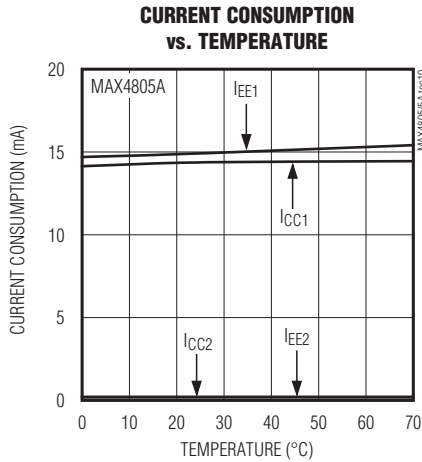

MAX4805/MAX4805A

Octal High-Voltage-Protected, Low-Power, Low-Noise Operational Amplifiers

Pin Configuration

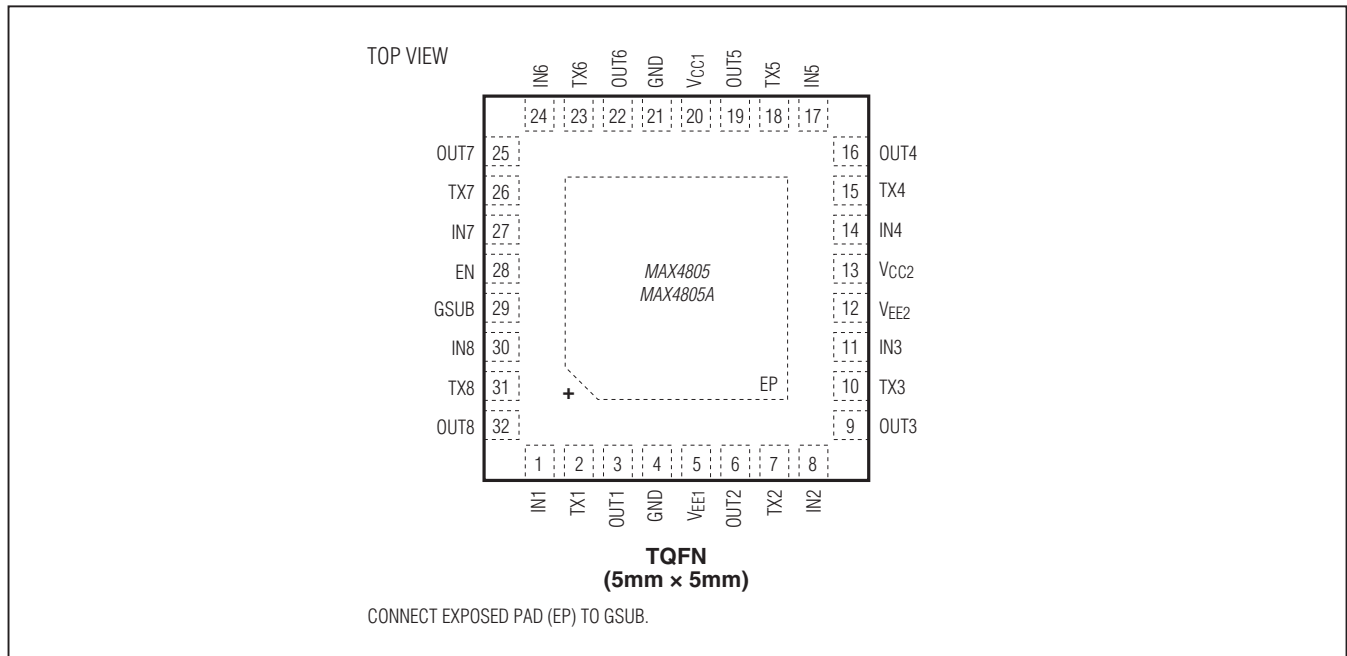

Pin Description

PIN	NAME	FUNCTION
1	IN1	Channel 1—LV Buffer Input. Connect a HV capacitor between TX1 and IN1 (see the <i>Applications Information</i> section).
2	TX1	Channel 1—HV Buffer Input. Connect TX1 to the transducer side.
3	OUT1	Channel 1—Buffer Output. Connect OUT1 to the cable side.
4, 21	GND	Ground
5	VEE1	Negative Op Amp Voltage Supply (-2V (typ)). Bypass VEE1 to GND with a 100nF ceramic capacitor.
6	OUT2	Channel 2—Buffer Output. Connect OUT2 to the cable side.
7	TX2	Channel 2—HV Buffer Input. Connect TX2 to the transducer side.
8	IN2	Channel 2—LV Buffer Input. Connect a HV capacitor between TX2 and IN2 (see the <i>Applications Information</i> section).
9	OUT3	Channel 3—Buffer Output. Connect OUT3 to the cable side.
10	TX3	Channel 3—HV Buffer Input. Connect TX3 to the transducer side.
11	IN3	Channel 3—LV Buffer Input. Connect a HV capacitor between TX3 and IN3 (see the <i>Applications Information</i> section).
12	VEE2	Negative T/R Switch Voltage Supply (-5V (typ)). Bypass VEE2 to GND with a 100nF ceramic capacitor.
13	VCC2	Positive T/R Switch Voltage Supply (+5V (typ)). Bypass VCC2 to GND with a 100nF ceramic capacitor.
14	IN4	Channel 4—LV Buffer Input. Connect a HV capacitor between TX4 and IN4 (see the <i>Applications Information</i> section).
15	TX4	Channel 4—HV Buffer Input. Connect TX4 to the transducer side.
16	OUT4	Channel 4—Buffer Output. Connect OUT4 to the cable side.

MAX4805/MAX4805A

Octal High-Voltage-Protected, Low-Power, Low-Noise Operational Amplifiers

Pin Description (continued)

PIN	NAME	FUNCTION
17	IN5	Channel 5—LV Buffer Input. Connect a HV capacitor between TX5 and IN5 (see the <i>Applications Information</i> section).
18	TX5	Channel 5—HV Buffer Input. Connect TX5 to the transducer side.
19	OUT5	Channel 5—Buffer Output. Connect OUT5 to the cable side.
20	VCC1	Positive Op Amp Voltage Supply (+2V (typ)). Bypass VCC1 to GND with a 100nF ceramic capacitor.
22	OUT6	Channel 6—Buffer Output. Connect OUT6 to the cable side.
23	TX6	Channel 6—HV Buffer Input. Connect TX6 to the transducer side.
24	IN6	Channel 6—LV Buffer Input. Connect a HV capacitor between TX6 and IN6 (see the <i>Applications Information</i> section).
25	OUT7	Channel 7—Buffer Output. Connect OUT7 to the cable side.
26	TX7	Channel 7—HV Buffer Input. Connect TX7 to the transducer side.
27	IN7	Channel 7—LV Buffer Input. Connect a HV capacitor between TX7 and IN7 (see the <i>Applications Information</i> section).
28	EN	Enable Input. CMOS-Level Input. Drive EN low to turn off op amp and three-state I/O. Drive EN high for normal operation.
29	GSUB	Substrate (lowest voltage in the system) (-100V). Bypass GSUB with a high-voltage, 100nF ceramic capacitor to GND.
30	IN8	Channel 8—LV Buffer Input. Connect a HV capacitor between TX8 and IN8 (see the <i>Applications Information</i> section).
31	TX8	Channel 8—HV Buffer Input. Connect TX8 to the transducer side.
32	OUT8	Channel 8—Buffer Output. Connect OUT8 to the cable side.
—	EP	Exposed Pad. Connect EP to GSUB.

Functional Diagram

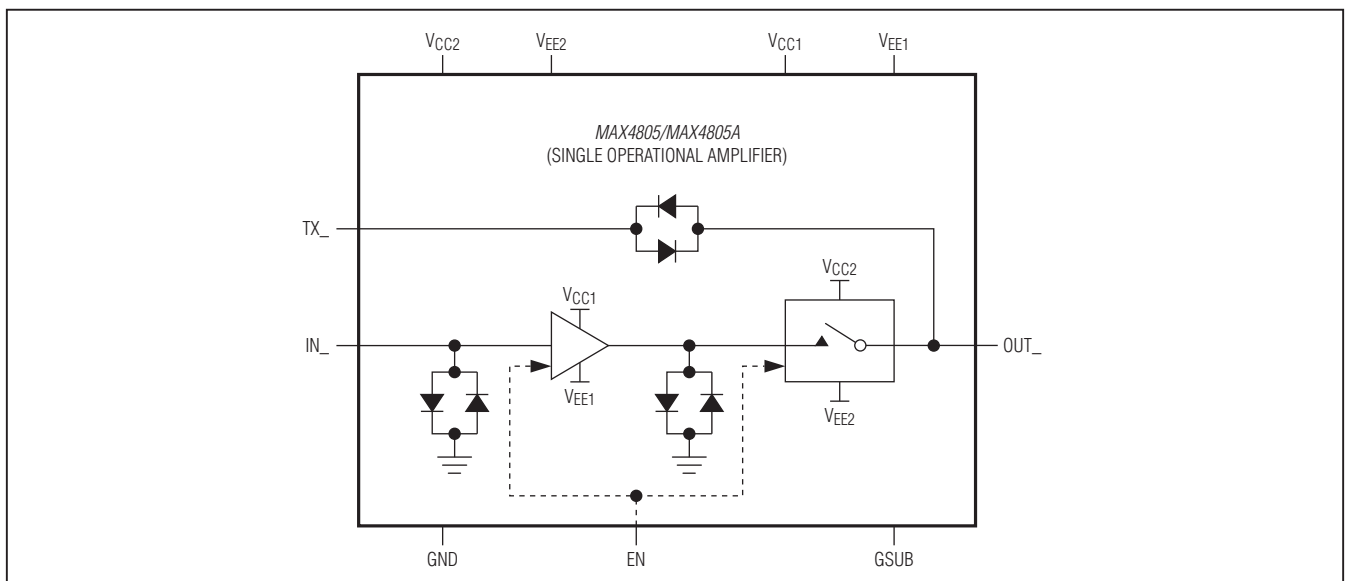

MAX4805/MAX4805A

Octal High-Voltage-Protected, Low-Power, Low-Noise Operational Amplifiers

Detailed Description

The MAX4805/MAX4805A are octal high-voltage-protected operational amplifiers. These devices are a fully integrated, very compact solution for in-probe amplification of echo signals coming from transducers in an ultrasound system.

The use of in-probe buffering improves system SNR for transducers featuring high-output impedance. This results in greater penetration depth and sensitivity. The MAX4805/MAX4805A can be adopted in ultrasound probes without any change in the system (scanner machine). Typical applications include high-impedance PZT and CMUT in-probe buffering and amplification. The MAX4805 is optimized for PZT applications, and the MAX4805A is optimized for CMUT applications.

The MAX4805/MAX4805A feature eight operational amplifiers configured in a noninverting configuration. The small-signal output impedance of these operational amplifiers is 65Ω (typ) for matching the typical cable impedance. The low-noise amplifier features 44MHz (typ) -3dB bandwidth and very low voltage and current noise, ensuring excellent noise figure.

The MAX4805/MAX4805A provide HV protection for inputs and outputs of the operational amplifiers. The operational amplifier inputs are protected by an external HV capacitor. An integrated automatic HV switch protects the output of the amplifier from HV bursts. Transmitted bursts reach the transducer through a pair of integrated antiparallel diodes. Each channel is able to sustain transmission bursts up to $\pm 100V$. The HV protection is automatically activated as soon as the TX voltage is greater than $\pm 2.7V$ (typ); no dedicated TX/RX signal is required.

The MAX4805 and the MAX4805A differ in terms of input current noise, input impedance, and voltage gain. Depending on the equivalent transducer source impedance, either the MAX4805 or the MAX4805A can be used to optimize a better noise figure.

Operational Amplifier

The MAX4805 features eight low-noise amplifiers (LNA) in a noninverting configuration with a 5.7dB (typ) gain. The MAX4805A features 8 LNAs in a noninverting configuration with a 9dB (typ) gain. These LNAs are enabled/disabled by the EN input.

Enable (EN)

Drive EN high to enable and connect all the operational amplifiers to the OUT_ outputs. Drive EN low to disable all the operational amplifiers and disconnect from the OUT_ outputs. When EN is low, the transmission is still possible and the power consumption is zero. This is useful in Continuous Wave Doppler (CWD) mode when typically half of the transducer array is used for transmit and half for receive (see Table 1).

Transmit/Receive (T/R) Switch

The output of the LNA is protected by an automatic T/R switch. When voltage at OUT_ exceeds the $\pm 2.7V$ (typ) thresholds, the switch is automatically opened (high-impedance). The switch is automatically closed (equivalent impedance 65Ω (typ)) when OUT_ is between the $\pm 2.7V$ (typ) thresholds. A dedicated control signal is not required to open or close the switch in typical ultrasound systems.

In addition, the switch can be controlled by the EN input. To use the device only in transmit mode (with zero power consumption), drive EN low. This is useful in CWD mode when typically half of the transducer array is used for transmit and half for receive (see Table 1).

Table 1. Truth Table

EN	OUT_	LNA STATUS	T/R SWITCH STATUS
Low	X	Shutdown	Open
High	$< V_{TH-}$	On	Open
High	$V_{TH-} < V_{OUT_} < V_{TH+}$	On	Closed (In Receive Mode)
High	$> V_{TH+}$	On	Open

X = Don't care.

$V_{TH+} = +2.7V$ (typ).

$V_{TH-} = -2.7V$ (typ).

MAX4805/MAX4805A

Octal High-Voltage-Protected, Low-Power, Low-Noise Operational Amplifiers

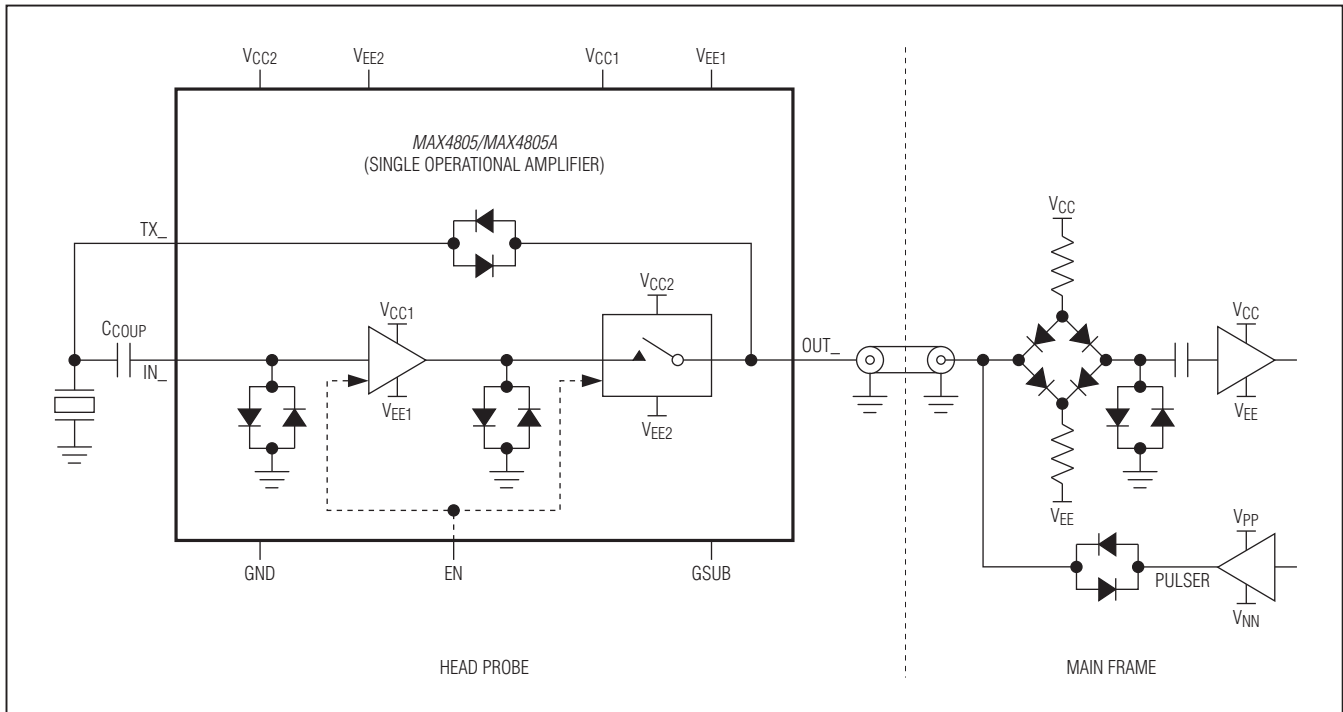

Figure 3. Ultrasound Probe Application Circuit

Applications Information

The use of MAX4805/MAX4805A can result in transmit signal attenuation. During transmission, the excitation burst reaching the transducer is typically attenuated because of the nonidealities of the automatic T/R switch and because of the capacitor connected between TX_ and IN_ that results in an extra load for the transmitter. This attenuation depends on the burst frequency and on-transmitter source impedance. It can typically be compensated by increasing the burst amplitude from the system.

The capacitor connected between TX_ and IN_ can be chosen in the 47pF to 150pF range depending on the equivalent output impedance of the transducer. A higher capacitance value guarantees a lower attenuation of the received echo signal at expenses of a greater attenuation of the transmit signal. Figure 3 shows a typical ultrasound probe application.

An accurate bypass of the voltage supply is required. In particular, it is recommended to have bypass capacitors on VCC1, VEE1, VCC2, VEE2, and GSUB pins as close as possible to the device. For noisy power supplies, a capacitor-inductor-capacitor (CLC) filter on each voltage supply is recommended.

Power-On/Power-Off Sequences

The MAX4805/MAX4805A do not require special power-on/off sequencing of the VCC1, VEE1, VCC2, and VEE2 supply voltage.

Note: Turn on GSUB first. Turning off GSUB last is recommended.

Supply Bypassing

Bypass VCC1, VEE1, VCC2, VEE2, and GSUB with 100nF capacitor as close as possible to the device.

Chip Information

PROCESS: BiCMOS

Package Information

For the latest package outline information and land patterns, go to www.maxim-ic.com/packages. Note that a "+", "#", or "-" in the package code indicates RoHS status only. Package drawings may show a different suffix character, but the drawing pertains to the package regardless of RoHS status.

PACKAGE TYPE	PACKAGE CODE	DOCUMENT NO.
32 TQFN-EP	T3255-4	21-0140

MAX4805/MAX4805A

Octal High-Voltage-Protected, Low-Power, Low-Noise Operational Amplifiers

Revision History

REVISION NUMBER	REVISION DATE	DESCRIPTION	PAGES CHANGED
0	4/10	Initial release	—



Maxim cannot assume responsibility for use of any circuitry other than circuitry entirely embodied in a Maxim product. No circuit patent licenses are implied. Maxim reserves the right to change the circuitry and specifications without notice at any time. The parametric values (min and max limits) shown in the Electrical Characteristics table are guaranteed. Other parametric values quoted in this data sheet are provided for guidance.

Looking for pricing, stock, or lifecycle information?

Click below to explore more details on WIN SOURCE:

 [View MAX4805ACTJ+ on WIN SOURCE](#)

 [Maxim Integrated](#) Information

Optimize Your Supply Chain with WIN SOURCE Solutions

-  Global Sourcing Solution
-  Obsolete Management
-  Cost Control Management
-  Shortage Management
-  Alternative Solution
-  Excess Inventory Management