



# SNx4HC4020 14-Bit Asynchronous Binary Counters

## 1 Features

- Wide operating voltage range of 2 V to 6 V
- Outputs can drive up to 10 LSTTL loads
- Low power consumption, 80- $\mu$ A max  $I_{CC}$
- Typical  $t_{pd} = 12$  ns
- $\pm 4$ -mA output drive at 5 V
- Low input current of 1  $\mu$ A max

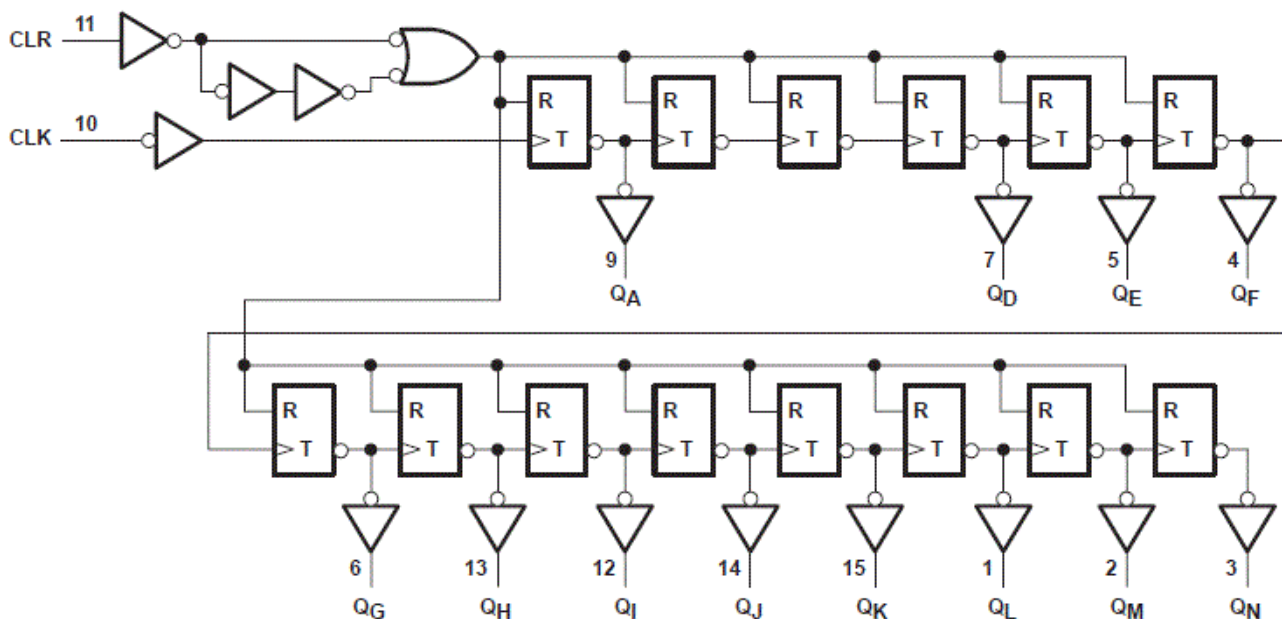
## 2 Description

The 'HC4020 devices are 14-stage binary ripple-carry counters that advance on the negative-going edge of the clock pulse. The counters are reset to zero (all outputs low) independently of the clock (CLK) input when the clear (CLR) input goes high.

### Device Information

PART NUMBER	PACKAGE <sup>(1)</sup>	BODY SIZE (NOM)
SN74HC4020D	SOIC (16)	9.90 mm × 3.90 mm
SN74HC4020N	PDIP (16)	19.31 mm × 6.35 mm
SN74HC4020NS	SO (16)	6.20 mm × 5.30 mm
SN74HC4020PW	TSSOP (16)	5.00 mm × 4.40 mm
SN54HC4020J	CDIP (16)	24.38 mm × 6.92 mm
SNJ54HC4020FK	LCCC (20)	8.89 mm × 8.45 mm
SNJ54HC4020W	CFP (16)	10.16 mm × 6.73 mm

(1) For all available packages, see the orderable addendum at the end of the data sheet.



Pin numbers shown are for the D, DB, J, N, NS, PW, and W packages.

### Functional Block Diagram



## Table of Contents

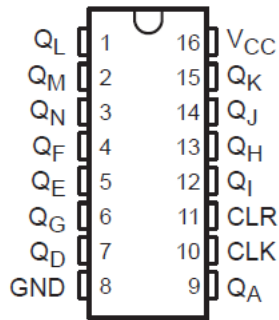
<b>1 Features</b> .....	1	7.2 Functional Block Diagram.....	8
<b>2 Description</b> .....	1	7.3 Device Functional Modes.....	8
<b>3 Revision History</b> .....	2	<b>8 Power Supply Recommendations</b> .....	9
<b>4 Pin Configuration and Functions</b> .....	3	<b>9 Layout</b> .....	9
<b>5 Specifications</b> .....	4	9.1 Layout Guidelines.....	9
5.1 Absolute Maximum Ratings.....	4	<b>10 Device and Documentation Support</b> .....	10
5.2 Recommended Operating Conditions <sup>(1)</sup> .....	4	10.1 Documentation Support.....	10
5.3 Thermal Information.....	4	10.2 Receiving Notification of Documentation Updates..	10
5.4 Electrical Characteristics.....	5	10.3 Support Resources.....	10
5.5 Timing Characteristics.....	5	10.4 Trademarks.....	10
5.6 Switching Characteristics.....	6	10.5 Electrostatic Discharge Caution.....	10
5.7 Operating Characteristics.....	6	10.6 Glossary.....	10
<b>6 Parameter Measurement Information</b> .....	7	<b>11 Mechanical, Packaging, and Orderable Information</b> .....	10
<b>7 Detailed Description</b> .....	8		
7.1 Overview.....	8		

### 3 Revision History

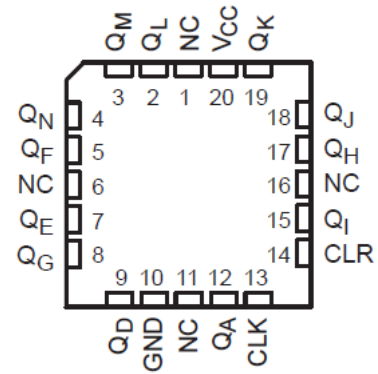
NOTE: Page numbers for previous revisions may differ from page numbers in the current version.

<b>Changes from Revision E (September 2003) to Revision F (February 2022)</b>	<b>Page</b>
• Updated the numbering, formatting, tables, figures, and cross-references throughout the document to reflect modern data sheet standards.....	1

## 4 Pin Configuration and Functions



**J, W, D, DB, N, NS, or PW Package**  
**16-Pin CDIP, CFP, SOIC, SSOP, PDIP, SO, or TSSOP**  
**Top View**



NC – No internal connection

**FK Package**  
**20-Pin LCCC**  
**Top View**

## 5 Specifications

### 5.1 Absolute Maximum Ratings

over operating free-air temperature range (unless otherwise noted)<sup>(1)</sup>

		MIN	MAX	UNIT
V <sub>CC</sub>	Supply voltage range	-0.5	7	V
I <sub>IK</sub>	Input clamp current <sup>(2)</sup>	(V <sub>I</sub> < 0 or V <sub>I</sub> > V <sub>CC</sub> )		±20 mA
I <sub>OK</sub>	Output clamp current <sup>(2)</sup>	(V <sub>O</sub> < 0 or V <sub>O</sub> > V <sub>CC</sub> )		±20 mA
I <sub>O</sub>	Continuous output current	(V <sub>O</sub> = 0 to V <sub>CC</sub> )		±25 mA
	Continuous current through V <sub>CC</sub> or GND			±50 mA
T <sub>J</sub>	Junction temperature			150 °C
T <sub>stg</sub>	Storage temperature	-65	150	°C

- (1) Stresses beyond those listed under *absolute maximum ratings* may cause permanent damage to the device. These are stress ratings only and functional operation of the device at these or any other conditions beyond those indicated under *recommended operating conditions* is not implied. Exposure to absolute-maximum-rated conditions for extended periods may affect device reliability.
- (2) The input and output voltage ratings may be exceeded if the input and output current ratings are observed.

### 5.2 Recommended Operating Conditions<sup>(1)</sup>

		SN54HC4020			SN74HC4020			UNIT
		MIN	NOM	MAX	MIN	NOM	MAX	
V <sub>CC</sub>	Supply voltage	2	5	6	2	5	6	V
V <sub>IH</sub>	High-level input voltage	V <sub>CC</sub> = 2 V		1.5	1.5		V	
		V <sub>CC</sub> = 4.5 V		3.15	3.15			
		V <sub>CC</sub> = 6 V		4.2	4.2			
V <sub>IL</sub>	Low-level input voltage	V <sub>CC</sub> = 2 V		0.5		0.5	V	
		V <sub>CC</sub> = 4.5 V		1.35		1.35		
		V <sub>CC</sub> = 6 V		1.8		1.8		
V <sub>I</sub>	Input voltage	0	V <sub>CC</sub>		0	V <sub>CC</sub>		V
V <sub>O</sub>	Output voltage	0	V <sub>CC</sub>		0	V <sub>CC</sub>		V
t <sub>t</sub>	Input transition rise/fall time	V <sub>CC</sub> = 2 V		1000		1000		ns
		V <sub>CC</sub> = 4.5 V		500		500		
		V <sub>CC</sub> = 6 V		400		400		
T <sub>A</sub>	Operating free-air temperature	-55		125	-40		85	°C

- (1) All unused inputs of the device must be held at V<sub>CC</sub> or GND to ensure proper device operation. Refer to the TI application report, Implications of Slow or Floating SMOS Inputs, literature number SCBA004.

### 5.3 Thermal Information

THERMAL METRIC		D (SOIC)	DB (SSOP)	N (PDIP)	NS (SO)	PW (TSSOP)	UNIT
		16 PINS	16 PINS	16 PINS	16 PINS	16 PINS	
R <sub>θJA</sub>	Junction-to-ambient thermal resistance <sup>(1)</sup>	73	82	67	64	108	°C/W

- (1) For more information about traditional and new thermal metrics, see the [Semiconductor and IC package thermal metrics](#) application report.

## 5.4 Electrical Characteristics

over recommended operating free-air temperature range (unless otherwise noted)

PARAMETER		TEST CONDITIONS <sup>(1)</sup>	V <sub>CC</sub> (V)	T <sub>A</sub> = 25°C			SN54HC4020		SN74HC4020		UNIT
				MIN	TYP	MAX	MIN	MAX	MIN	MAX	
V <sub>OH</sub>	High-level output voltage	I <sub>OH</sub> = –20 μA	2	1.9	1.998		1.9		1.9	V	
			4.5	4.4	4.499		4.4		4.4		
			6	5.9	5.999		5.9		5.9		
		I <sub>OH</sub> = –4 mA	4.5	3.98	4.3		3.7		3.84		
			6	5.48	5.8		5.2		5.34		
V <sub>OL</sub>	Low-level output voltage	I <sub>OL</sub> = 20 μA	2		0.002	0.1		0.1	0.1	V	
			4.5		0.001	0.1		0.1	0.1		
			6		0.001	0.1		0.1	0.1		
		I <sub>OL</sub> = 4 mA	4.5		0.17	0.26		0.4	0.33		
			6		0.15	0.26		0.4	0.33		
I <sub>I</sub>	Input hold current	V <sub>I</sub> = V <sub>CC</sub> or 0	6		±0.1	±100		±1000	±1000	nA	
I <sub>CC</sub>	Supply current	V <sub>I</sub> = V <sub>CC</sub> or 0. I <sub>O</sub> = 0	6			8		160	80	μA	
C <sub>i</sub>	Input capacitance		2 to 6		3	10		10	10	pF	

(1) V<sub>I</sub> = V<sub>IH</sub> or V<sub>IL</sub>, unless otherwise noted.

## 5.5 Timing Characteristics

over recommended operating free-air temperature range (unless otherwise noted)

			V <sub>CC</sub> (V)	T <sub>A</sub> = 25°C		SN54HC4020		SN74HC4020		UNIT
				MIN	MAX	MIN	MAX	MIN	MAX	
f <sub>CLK</sub>	Clock frequency		2		5.5		3.7		4.3	MHz
			4.5		28		19		22	
			6		33		22		25	
t <sub>w</sub>	Pulse duration	CLK high or low	2	90		135		115		ns
			4.5	18		27		23		
			6	15		23		20		
		CLR high	2	70		105		90		
			4.5	14		21		18		
			6	12		18		25		
t <sub>su</sub>	Setup time, CLR inactive before CLK↓		2	60		90		75	ns	
			4.5	12		18		15		
			6	10		15		13		

### 5.6 Switching Characteristics

$C_L = 50$  pF. See [Parameter Measurement Information](#)

PARAMETER	FROM (INPUT)	TO (OUTPUT)	$V_{CC}$ (V)	$T_A = 25^\circ\text{C}$			SN54HC4020		SN74HC4020		UNIT
				MIN	TYP	MAX	MIN	MAX	MIN	MAX	
$f_{max}$			2	5.5	10		3.7		4.3	ns	
			4.5	28	45		19		22		
			6	33	53		22		25		
$t_{pd}$	CLK	$Q_A$	2		62	150		225		190	ns
			4.5		16	30		45		38	
			6		12	26		38		32	
$t_{PHL}$	CLR	Any	2		63	140		210		175	ns
			4.5		17	28		42		35	
			6		13	24		36		30	
$t_t$		Any	2		28	75		110		95	ns
			4.5		8	15		22		19	
			6		6	13		19		16	

### 5.7 Operating Characteristics

$T_A = 25^\circ\text{C}$

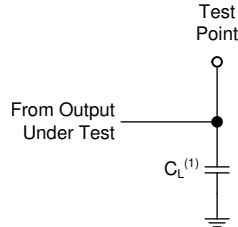
PARAMETER		TEST CONDITIONS	TYP	UNIT
$C_{pd}$	Power dissipation capacitance	No load	88	pF

## 6 Parameter Measurement Information

Phase relationships between waveforms were chosen arbitrarily. All input pulses are supplied by generators having the following characteristics:  $PRR \leq 1 \text{ MHz}$ ,  $Z_O = 50 \Omega$ ,  $t_t < 6 \text{ ns}$ .

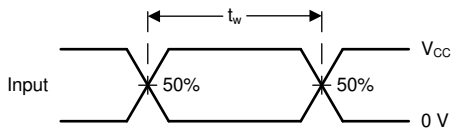
For clock inputs,  $f_{max}$  is measured when the input duty cycle is 50%.

The outputs are measured one at a time with one input transition per measurement.

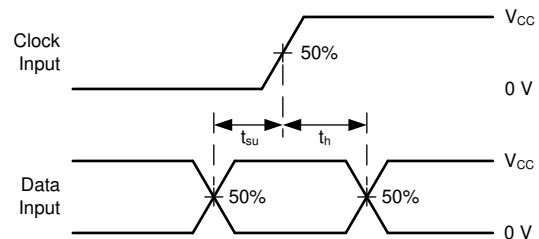


(1)  $C_L$  includes probe and test-fixture capacitance.

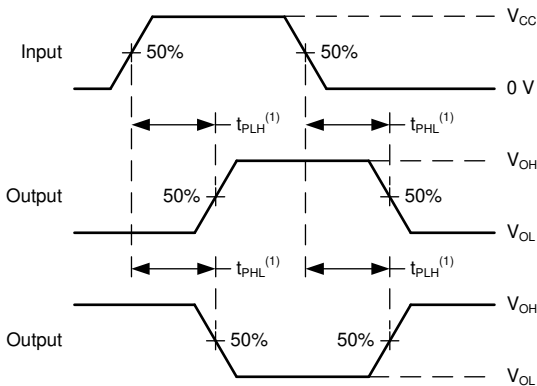
**Figure 6-1. Load Circuit for Push-Pull Outputs**



**Figure 6-2. Voltage Waveforms, Standard CMOS Inputs Pulse Duration**

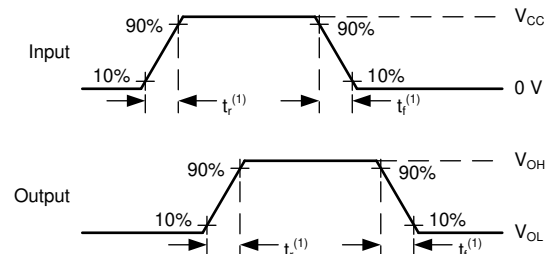


**Figure 6-3. Voltage Waveforms, Standard CMOS Inputs Setup and Hold Times**



(1) The greater between  $t_{PLH}$  and  $t_{PHL}$  is the same as  $t_{pd}$ .

**Figure 6-4. Voltage Waveforms, Propagation Delays for Standard CMOS Inputs**



(1) The greater between  $t_r$  and  $t_f$  is the same as  $t_t$ .

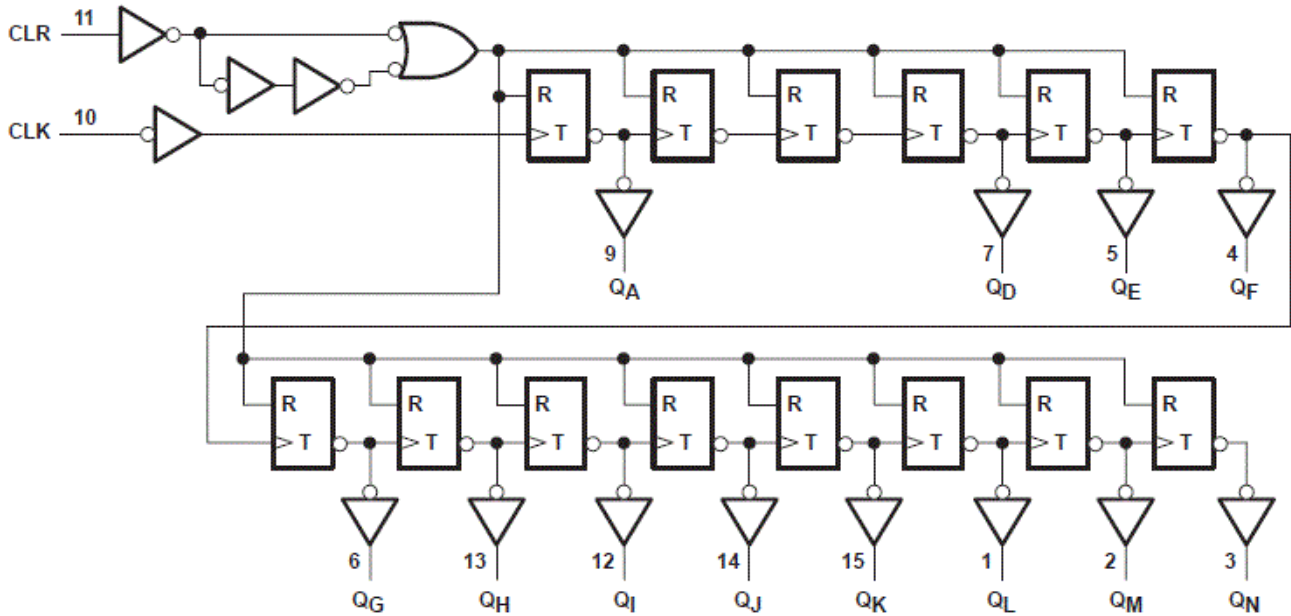
**Figure 6-5. Voltage Waveforms, Input and Output Transition Times for Standard CMOS Inputs**

## 7 Detailed Description

### 7.1 Overview

The 'HC4020 devices are 14-stage binary ripple-carry counters that advance on the negative-going edge of the clock (CLK) input when the clear (CLR) input goes high.

### 7.2 Functional Block Diagram



Pin numbers shown are for the D, DB, J, N, NS, PW, and W packages.

**Figure 7-1. Functional Block Diagram**

### 7.3 Device Functional Modes

**Function Table  
(each buffer)**

INPUTS		FUNCTION
CLK	CLR	
↑	L	No change
↓	L	Advance to next stage
X	H	All outputs L

## 8 Power Supply Recommendations

The power supply can be any voltage between the minimum and maximum supply voltage rating located in the *Recommended Operating Conditions*. Each  $V_{CC}$  terminal should have a good bypass capacitor to prevent power disturbance. A 0.1- $\mu\text{F}$  capacitor is recommended for this device. It is acceptable to parallel multiple bypass caps to reject different frequencies of noise. The 0.1- $\mu\text{F}$  and 1- $\mu\text{F}$  capacitors are commonly used in parallel. The bypass capacitor should be installed as close to the power terminal as possible for best results.

## 9 Layout

### 9.1 Layout Guidelines

When using multiple-input and multiple-channel logic devices inputs must not ever be left floating. In many cases, functions or parts of functions of digital logic devices are unused; for example, when only two inputs of a triple-input AND gate are used or only 3 of the 4 buffer gates are used. Such unused input pins must not be left unconnected because the undefined voltages at the outside connections result in undefined operational states. All unused inputs of digital logic devices must be connected to a logic high or logic low voltage, as defined by the input voltage specifications, to prevent them from floating. The logic level that must be applied to any particular unused input depends on the function of the device. Generally, the inputs are tied to GND or  $V_{CC}$ , whichever makes more sense for the logic function or is more convenient.

## 10 Device and Documentation Support

TI offers an extensive line of development tools. Tools and software to evaluate the performance of the device, generate code, and develop solutions are listed below.

### 10.1 Documentation Support

#### 10.1.1 Related Documentation

### 10.2 Receiving Notification of Documentation Updates

To receive notification of documentation updates, navigate to the device product folder on [ti.com](http://ti.com). Click on *Subscribe to updates* to register and receive a weekly digest of any product information that has changed. For change details, review the revision history included in any revised document.

### 10.3 Support Resources

TI E2E™ [support forums](#) are an engineer's go-to source for fast, verified answers and design help — straight from the experts. Search existing answers or ask your own question to get the quick design help you need.

Linked content is provided "AS IS" by the respective contributors. They do not constitute TI specifications and do not necessarily reflect TI's views; see TI's [Terms of Use](#).

### 10.4 Trademarks

TI E2E™ is a trademark of Texas Instruments.

All trademarks are the property of their respective owners.

### 10.5 Electrostatic Discharge Caution



This integrated circuit can be damaged by ESD. Texas Instruments recommends that all integrated circuits be handled with appropriate precautions. Failure to observe proper handling and installation procedures can cause damage.

ESD damage can range from subtle performance degradation to complete device failure. Precision integrated circuits may be more susceptible to damage because very small parametric changes could cause the device not to meet its published specifications.

### 10.6 Glossary

[TI Glossary](#) This glossary lists and explains terms, acronyms, and definitions.

## 11 Mechanical, Packaging, and Orderable Information

The following pages include mechanical, packaging, and orderable information. This information is the most current data available for the designated devices. This data is subject to change without notice and revision of this document. For browser-based versions of this data sheet, refer to the left-hand navigation.

## PACKAGING INFORMATION

Orderable Device	Status (1)	Package Type	Package Drawing	Pins	Package Qty	Eco Plan (2)	Lead finish/ Ball material (6)	MSL Peak Temp (3)	Op Temp (°C)	Device Marking (4/5)	Samples
85003012A	ACTIVE	LCCC	FK	20	1	Non-RoHS & Green	SNPB	N / A for Pkg Type	-55 to 125	85003012A SNJ54HC 4020FK	<a href="#">Samples</a>
8500301EA	ACTIVE	CDIP	J	16	1	Non-RoHS & Green	SNPB	N / A for Pkg Type	-55 to 125	8500301EA SNJ54HC4020J	<a href="#">Samples</a>
8500301FA	ACTIVE	CFP	W	16	1	Non-RoHS & Green	SNPB	N / A for Pkg Type	-55 to 125	8500301FA SNJ54HC4020W	<a href="#">Samples</a>
SN54HC4020J	ACTIVE	CDIP	J	16	1	Non-RoHS & Non-Green	SNPB	N / A for Pkg Type	-55 to 125	SN54HC4020J	<a href="#">Samples</a>
SN74HC4020D	ACTIVE	SOIC	D	16	40	RoHS & Green	NIPDAU	Level-1-260C-UNLIM	-40 to 85	HC4020	<a href="#">Samples</a>
SN74HC4020DR	ACTIVE	SOIC	D	16	2500	RoHS & Green	NIPDAU	Level-1-260C-UNLIM	-40 to 85	HC4020	<a href="#">Samples</a>
SN74HC4020N	ACTIVE	PDIP	N	16	25	RoHS & Green	NIPDAU	N / A for Pkg Type	-40 to 85	SN74HC4020N	<a href="#">Samples</a>
SN74HC4020NSR	ACTIVE	SO	NS	16	2000	RoHS & Green	NIPDAU	Level-1-260C-UNLIM	-40 to 85	HC4020	<a href="#">Samples</a>
SN74HC4020PW	ACTIVE	TSSOP	PW	16	90	RoHS & Green	NIPDAU	Level-1-260C-UNLIM	-40 to 85	HC4020	<a href="#">Samples</a>
SN74HC4020PWR	ACTIVE	TSSOP	PW	16	2000	RoHS & Green	NIPDAU	Level-1-260C-UNLIM	-40 to 85	HC4020	<a href="#">Samples</a>
SN74HC4020PWT	ACTIVE	TSSOP	PW	16	250	RoHS & Green	NIPDAU	Level-1-260C-UNLIM	-40 to 85	HC4020	<a href="#">Samples</a>
SNJ54HC4020FK	ACTIVE	LCCC	FK	20	1	Non-RoHS & Green	SNPB	N / A for Pkg Type	-55 to 125	85003012A SNJ54HC 4020FK	<a href="#">Samples</a>
SNJ54HC4020J	ACTIVE	CDIP	J	16	1	Non-RoHS & Green	SNPB	N / A for Pkg Type	-55 to 125	8500301EA SNJ54HC4020J	<a href="#">Samples</a>
SNJ54HC4020W	ACTIVE	CFP	W	16	1	Non-RoHS & Green	SNPB	N / A for Pkg Type	-55 to 125	8500301FA SNJ54HC4020W	<a href="#">Samples</a>

(1) The marketing status values are defined as follows:

**ACTIVE:** Product device recommended for new designs.

**LIFEBUY:** TI has announced that the device will be discontinued, and a lifetime-buy period is in effect.

**NRND:** Not recommended for new designs. Device is in production to support existing customers, but TI does not recommend using this part in a new design.

**PREVIEW:** Device has been announced but is not in production. Samples may or may not be available.

**OBSOLETE:** TI has discontinued the production of the device.

(2) **RoHS:** TI defines "RoHS" to mean semiconductor products that are compliant with the current EU RoHS requirements for all 10 RoHS substances, including the requirement that RoHS substance do not exceed 0.1% by weight in homogeneous materials. Where designed to be soldered at high temperatures, "RoHS" products are suitable for use in specified lead-free processes. TI may reference these types of products as "Pb-Free".

**RoHS Exempt:** TI defines "RoHS Exempt" to mean products that contain lead but are compliant with EU RoHS pursuant to a specific EU RoHS exemption.

**Green:** TI defines "Green" to mean the content of Chlorine (Cl) and Bromine (Br) based flame retardants meet JS709B low halogen requirements of  $\leq 1000$ ppm threshold. Antimony trioxide based flame retardants must also meet the  $\leq 1000$ ppm threshold requirement.

(3) MSL, Peak Temp. - The Moisture Sensitivity Level rating according to the JEDEC industry standard classifications, and peak solder temperature.

(4) There may be additional marking, which relates to the logo, the lot trace code information, or the environmental category on the device.

(5) Multiple Device Markings will be inside parentheses. Only one Device Marking contained in parentheses and separated by a "~" will appear on a device. If a line is indented then it is a continuation of the previous line and the two combined represent the entire Device Marking for that device.

(6) Lead finish/Ball material - Orderable Devices may have multiple material finish options. Finish options are separated by a vertical ruled line. Lead finish/Ball material values may wrap to two lines if the finish value exceeds the maximum column width.

**Important Information and Disclaimer:**The information provided on this page represents TI's knowledge and belief as of the date that it is provided. TI bases its knowledge and belief on information provided by third parties, and makes no representation or warranty as to the accuracy of such information. Efforts are underway to better integrate information from third parties. TI has taken and continues to take reasonable steps to provide representative and accurate information but may not have conducted destructive testing or chemical analysis on incoming materials and chemicals. TI and TI suppliers consider certain information to be proprietary, and thus CAS numbers and other limited information may not be available for release.

In no event shall TI's liability arising out of such information exceed the total purchase price of the TI part(s) at issue in this document sold by TI to Customer on an annual basis.

**OTHER QUALIFIED VERSIONS OF SN54HC4020, SN74HC4020 :**

● Catalog : [SN74HC4020](#)

● Military : [SN54HC4020](#)

NOTE: Qualified Version Definitions:

● Catalog - TI's standard catalog product

● Military - QML certified for Military and Defense Applications

**TAPE AND REEL INFORMATION**

**QUADRANT ASSIGNMENTS FOR PIN 1 ORIENTATION IN TAPE**


\*All dimensions are nominal

Device	Package Type	Package Drawing	Pins	SPQ	Reel Diameter (mm)	Reel Width W1 (mm)	A0 (mm)	B0 (mm)	K0 (mm)	P1 (mm)	W (mm)	Pin1 Quadrant
SN74HC4020DR	SOIC	D	16	2500	330.0	16.4	6.5	10.3	2.1	8.0	16.0	Q1
SN74HC4020NSR	SO	NS	16	2000	330.0	16.4	8.2	10.5	2.5	12.0	16.0	Q1
SN74HC4020PWR	TSSOP	PW	16	2000	330.0	12.4	6.9	5.6	1.6	8.0	12.0	Q1
SN74HC4020PWR	TSSOP	PW	16	2000	330.0	12.4	6.9	5.6	1.6	8.0	12.0	Q1
SN74HC4020PWR	TSSOP	PW	16	2000	330.0	12.4	6.85	5.45	1.6	8.0	12.0	Q1

**TAPE AND REEL BOX DIMENSIONS**


\*All dimensions are nominal

Device	Package Type	Package Drawing	Pins	SPQ	Length (mm)	Width (mm)	Height (mm)
SN74HC4020DR	SOIC	D	16	2500	356.0	356.0	35.0
SN74HC4020NSR	SO	NS	16	2000	356.0	356.0	35.0
SN74HC4020PWR	TSSOP	PW	16	2000	356.0	356.0	35.0
SN74HC4020PWR	TSSOP	PW	16	2000	356.0	356.0	35.0
SN74HC4020PWR	TSSOP	PW	16	2000	366.0	364.0	50.0

**TUBE**


\*All dimensions are nominal

Device	Package Name	Package Type	Pins	SPQ	L (mm)	W (mm)	T (μm)	B (mm)
85003012A	FK	LCCC	20	55	506.98	12.06	2030	NA
8500301FA	W	CFP	16	25	506.98	26.16	6220	NA
SN74HC4020N	N	PDIP	16	25	506	13.97	11230	4.32
SN74HC4020N	N	PDIP	16	25	506	13.97	11230	4.32
SNJ54HC4020FK	FK	LCCC	20	55	506.98	12.06	2030	NA
SNJ54HC4020W	W	CFP	16	25	506.98	26.16	6220	NA

W (R-GDFP-F16)

CERAMIC DUAL FLATPACK



- NOTES:
- A. All linear dimensions are in inches (millimeters).
  - B. This drawing is subject to change without notice.
  - C. This package can be hermetically sealed with a ceramic lid using glass frit.
  - D. Index point is provided on cap for terminal identification only.
  - E. Falls within MIL STD 1835 GDFP2-F16

## GENERIC PACKAGE VIEW

**FK 20**

**LCCC - 2.03 mm max height**

8.89 x 8.89, 1.27 mm pitch

LEADLESS CERAMIC CHIP CARRIER

This image is a representation of the package family, actual package may vary.  
Refer to the product data sheet for package details.



4229370VA\

J (R-GDIP-T\*\*)

14 LEADS SHOWN

CERAMIC DUAL IN-LINE PACKAGE



DIM \ PINS **	14	16	18	20
A	0.300 (7,62) BSC	0.300 (7,62) BSC	0.300 (7,62) BSC	0.300 (7,62) BSC
B MAX	0.785 (19,94)	.840 (21,34)	0.960 (24,38)	1.060 (26,92)
B MIN	—	—	—	—
C MAX	0.300 (7,62)	0.300 (7,62)	0.310 (7,87)	0.300 (7,62)
C MIN	0.245 (6,22)	0.245 (6,22)	0.220 (5,59)	0.245 (6,22)



4040083/F 03/03

- NOTES:
- All linear dimensions are in inches (millimeters).
  - This drawing is subject to change without notice.
  - This package is hermetically sealed with a ceramic lid using glass frit.
  - Index point is provided on cap for terminal identification only on press ceramic glass frit seal only.
  - Falls within MIL STD 1835 GDIP1-T14, GDIP1-T16, GDIP1-T18 and GDIP1-T20.

N (R-PDIP-T\*\*)

PLASTIC DUAL-IN-LINE PACKAGE

16 PINS SHOWN



4040049/E 12/2002

- NOTES:
- A. All linear dimensions are in inches (millimeters).
  - B. This drawing is subject to change without notice.
  - (C) Falls within JEDEC MS-001, except 18 and 20 pin minimum body length (Dim A).
  - (D) The 20 pin end lead shoulder width is a vendor option, either half or full width.



# PACKAGE OUTLINE

## NS0016A

### SOP - 2.00 mm max height

SOP



#### NOTES:

1. All linear dimensions are in millimeters. Dimensions in parenthesis are for reference only. Dimensioning and tolerancing per ASME Y14.5M.
2. This drawing is subject to change without notice.
3. This dimension does not include mold flash, protrusions, or gate burrs. Mold flash, protrusions, or gate burrs shall not exceed 0.15 mm, per side.
4. This dimension does not include interlead flash. Interlead flash shall not exceed 0.25 mm, per side.

# EXAMPLE BOARD LAYOUT

NS0016A

SOP - 2.00 mm max height

SOP



4220735/A 12/2021

NOTES: (continued)

5. Publication IPC-7351 may have alternate designs.

6. Solder mask tolerances between and around signal pads can vary based on board fabrication site.

# EXAMPLE STENCIL DESIGN

NS0016A

SOP - 2.00 mm max height

SOP



SOLDER PASTE EXAMPLE  
BASED ON 0.125 mm THICK STENCIL  
SCALE:7X

4220735/A 12/2021

NOTES: (continued)

7. Laser cutting apertures with trapezoidal walls and rounded corners may offer better paste release. IPC-7525 may have alternate design recommendations.
8. Board assembly site may have different recommendations for stencil design.

D (R-PDSO-G16)

PLASTIC SMALL OUTLINE



- NOTES:
- A. All linear dimensions are in inches (millimeters).
  - B. This drawing is subject to change without notice.
  - C. Body length does not include mold flash, protrusions, or gate burrs. Mold flash, protrusions, or gate burrs shall not exceed 0.006 (0,15) each side.
  - D. Body width does not include interlead flash. Interlead flash shall not exceed 0.017 (0,43) each side.
  - E. Reference JEDEC MS-012 variation AC.



4220204/A 02/2017

NOTES:

1. All linear dimensions are in millimeters. Any dimensions in parenthesis are for reference only. Dimensioning and tolerancing per ASME Y14.5M.
2. This drawing is subject to change without notice.
3. This dimension does not include mold flash, protrusions, or gate burrs. Mold flash, protrusions, or gate burrs shall not exceed 0.15 mm per side.
4. This dimension does not include interlead flash. Interlead flash shall not exceed 0.25 mm per side.
5. Reference JEDEC registration MO-153.

# EXAMPLE BOARD LAYOUT

PW0016A

TSSOP - 1.2 mm max height

SMALL OUTLINE PACKAGE



LAND PATTERN EXAMPLE  
EXPOSED METAL SHOWN  
SCALE: 10X



SOLDER MASK DETAILS

4220204/A 02/2017

NOTES: (continued)

- 6. Publication IPC-7351 may have alternate designs.
- 7. Solder mask tolerances between and around signal pads can vary based on board fabrication site.

# EXAMPLE STENCIL DESIGN

PW0016A

TSSOP - 1.2 mm max height

SMALL OUTLINE PACKAGE



SOLDER PASTE EXAMPLE  
BASED ON 0.125 mm THICK STENCIL  
SCALE: 10X

4220204/A 02/2017

NOTES: (continued)

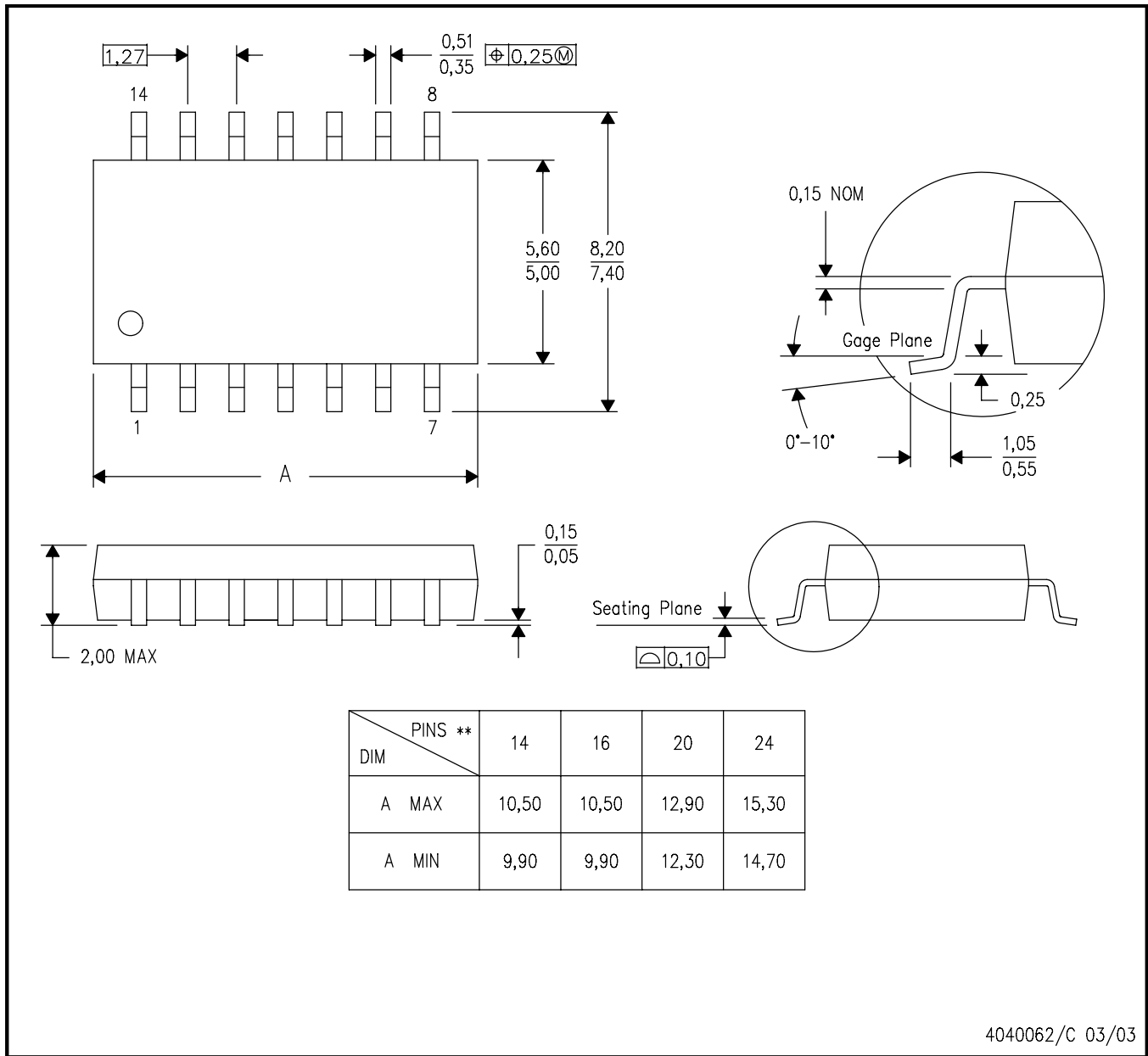
8. Laser cutting apertures with trapezoidal walls and rounded corners may offer better paste release. IPC-7525 may have alternate design recommendations.
9. Board assembly site may have different recommendations for stencil design.

# MECHANICAL DATA

NS (R-PDSO-G\*\*)

PLASTIC SMALL-OUTLINE PACKAGE

14-PINS SHOWN



- NOTES:
- A. All linear dimensions are in millimeters.
  - B. This drawing is subject to change without notice.
  - C. Body dimensions do not include mold flash or protrusion, not to exceed 0,15.

## IMPORTANT NOTICE AND DISCLAIMER

TI PROVIDES TECHNICAL AND RELIABILITY DATA (INCLUDING DATA SHEETS), DESIGN RESOURCES (INCLUDING REFERENCE DESIGNS), APPLICATION OR OTHER DESIGN ADVICE, WEB TOOLS, SAFETY INFORMATION, AND OTHER RESOURCES "AS IS" AND WITH ALL FAULTS, AND DISCLAIMS ALL WARRANTIES, EXPRESS AND IMPLIED, INCLUDING WITHOUT LIMITATION ANY IMPLIED WARRANTIES OF MERCHANTABILITY, FITNESS FOR A PARTICULAR PURPOSE OR NON-INFRINGEMENT OF THIRD PARTY INTELLECTUAL PROPERTY RIGHTS.

These resources are intended for skilled developers designing with TI products. You are solely responsible for (1) selecting the appropriate TI products for your application, (2) designing, validating and testing your application, and (3) ensuring your application meets applicable standards, and any other safety, security, regulatory or other requirements.

These resources are subject to change without notice. TI grants you permission to use these resources only for development of an application that uses the TI products described in the resource. Other reproduction and display of these resources is prohibited. No license is granted to any other TI intellectual property right or to any third party intellectual property right. TI disclaims responsibility for, and you will fully indemnify TI and its representatives against, any claims, damages, costs, losses, and liabilities arising out of your use of these resources.

TI's products are provided subject to [TI's Terms of Sale](#) or other applicable terms available either on [ti.com](https://www.ti.com) or provided in conjunction with such TI products. TI's provision of these resources does not expand or otherwise alter TI's applicable warranties or warranty disclaimers for TI products.

TI objects to and rejects any additional or different terms you may have proposed.

Mailing Address: Texas Instruments, Post Office Box 655303, Dallas, Texas 75265  
Copyright © 2024, Texas Instruments Incorporated

## Looking for pricing, stock, or lifecycle information?

Click below to explore more details on WIN SOURCE:

 [View SN74HC4020DBR on WIN SOURCE](#)

 [Texas Instruments](#) Information

## Optimize Your Supply Chain with WIN SOURCE Solutions

-  Global Sourcing Solution
-  Obsolete Management
-  Cost Control Management
-  Shortage Management
-  Alternative Solution
-  Excess Inventory Management