



**THE DATASHEET OF
SN74ALVC7813-40DL**



LOW-POWER CLOCKED FIRST-IN, FIRST-OUT MEMORY

SCAS594A – OCTOBER 1997 – REVISED APRIL 1998

- Member of the Texas Instruments Widebus™ Family
- Low-Power Advanced CMOS Technology
- Operates From 3-V to 3.6-V V_{CC}
- Free-Running Read and Write Clocks Can Be Asynchronous or Coincident
- Read and Write Operations Synchronized to Independent System Clocks
- Half-Full Flag and Programmable Almost-Full/Almost-Empty Flag
- Bidirectional Configuration and Width Expansion Without Additional Logic
- Input-Ready Flag Synchronized to Write Clock
- Output-Ready Flag Synchronized to Read Clock
- Fast Access Times of 13 ns With a 50-pF Load and All Data Outputs Switching Simultaneously
- Data Rates up to 50 MHz
- Pin-to-Pin Compatible With SN74ACT7803, SN74ACT7805, and SN74ACT7813
- Packaged in Shrink Small-Outline 300-mil Package Using 25-mil Center-to-Center Lead Spacing

description

The SN74ALVC7813 is suited for buffering asynchronous data paths up to 50-MHz clock rates and 13-ns access times. This device is designed for 3-V to 3.6-V V_{CC} operation. Two devices can be configured for bidirectional data buffering without additional logic.

The write clock (WRTCLK) and read clock (RDCLK) are free running and can be asynchronous or coincident. Data is written to memory on the rising edge of WRTCLK when $\overline{WRTEN1}$ is high, $\overline{WRTEN2}$ is low, and input ready (IR) is high. Data is read from memory on the rising edge of RDCLK when \overline{RDEN} , $\overline{OE1}$, and $\overline{OE2}$ are low and output ready (OR) is high. The first word written to memory is clocked through to the output buffer, regardless of the \overline{RDEN} , $\overline{OE1}$, and $\overline{OE2}$ levels. The OR flag indicates that valid data is present on the output buffer.

The FIFO can be reset asynchronously to WRTCLK and RDCLK. Reset (\overline{RESET}) must be asserted while at least four WRTCLK and four RDCLK rising edges occur to clear the synchronizing registers. Resetting the FIFO initializes the IR, OR, and half-full (HF) flags low and the almost-full/almost-empty (AF/AE) flag high. The FIFO must be reset upon power up.

The SN74ALVC7813 is characterized for operation from 0°C to 70°C.



Please be aware that an important notice concerning availability, standard warranty, and use in critical applications of Texas Instruments semiconductor products and disclaimers thereto appears at the end of this data sheet.

Widebus is a trademark of Texas Instruments Incorporated.

PRODUCTION DATA information is current as of publication date. Products conform to specifications per the terms of Texas Instruments standard warranty. Production processing does not necessarily include testing of all parameters.



POST OFFICE BOX 655303 • DALLAS, TEXAS 75265

Copyright © 1998, Texas Instruments Incorporated

DL PACKAGE
(TOP VIEW)

\overline{RESET}	1	56	$\overline{OE1}$
D17	2	55	Q17
D16	3	54	Q16
D15	4	53	Q15
D14	5	52	GND
D13	6	51	Q14
D12	7	50	V_{CC}
D11	8	49	Q13
D10	9	48	Q12
V_{CC}	10	47	Q11
D9	11	46	Q10
D8	12	45	Q9
GND	13	44	GND
D7	14	43	Q8
D6	15	42	Q7
D5	16	41	Q6
D4	17	40	Q5
D3	18	39	V_{CC}
D2	19	38	Q4
D1	20	37	Q3
D0	21	36	Q2
HF	22	35	GND
\overline{PEN}	23	34	Q1
AF/AE	24	33	Q0
WRTCLK	25	32	RDCLK
$\overline{WRTEN2}$	26	31	\overline{RDEN}
$\overline{WRTEN1}$	27	30	$\overline{OE2}$
IR	28	29	OR

logic symbol†

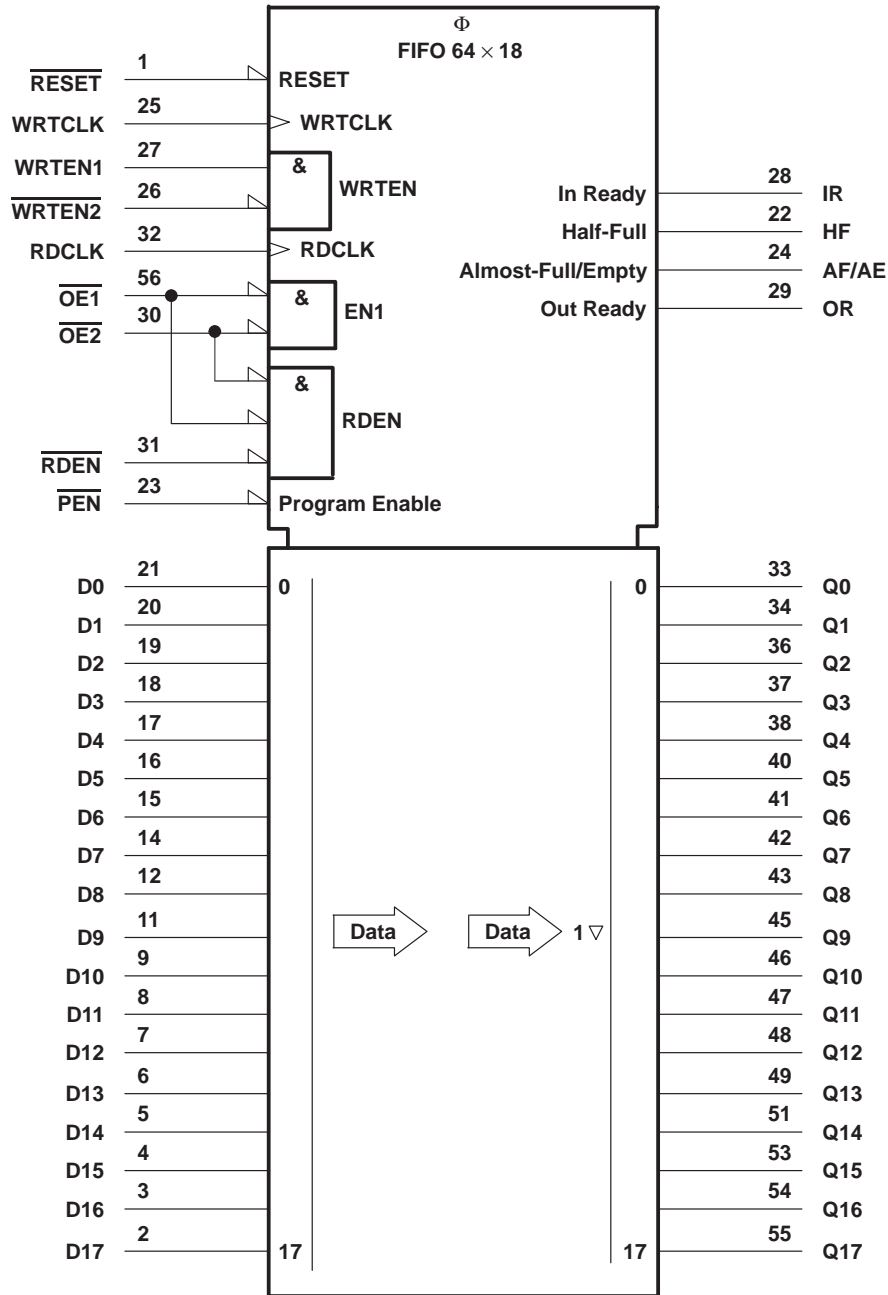

† This symbol is in accordance with ANSI/IEEE Std 91-1984 and IEC Publication 617-12.

functional block diagram

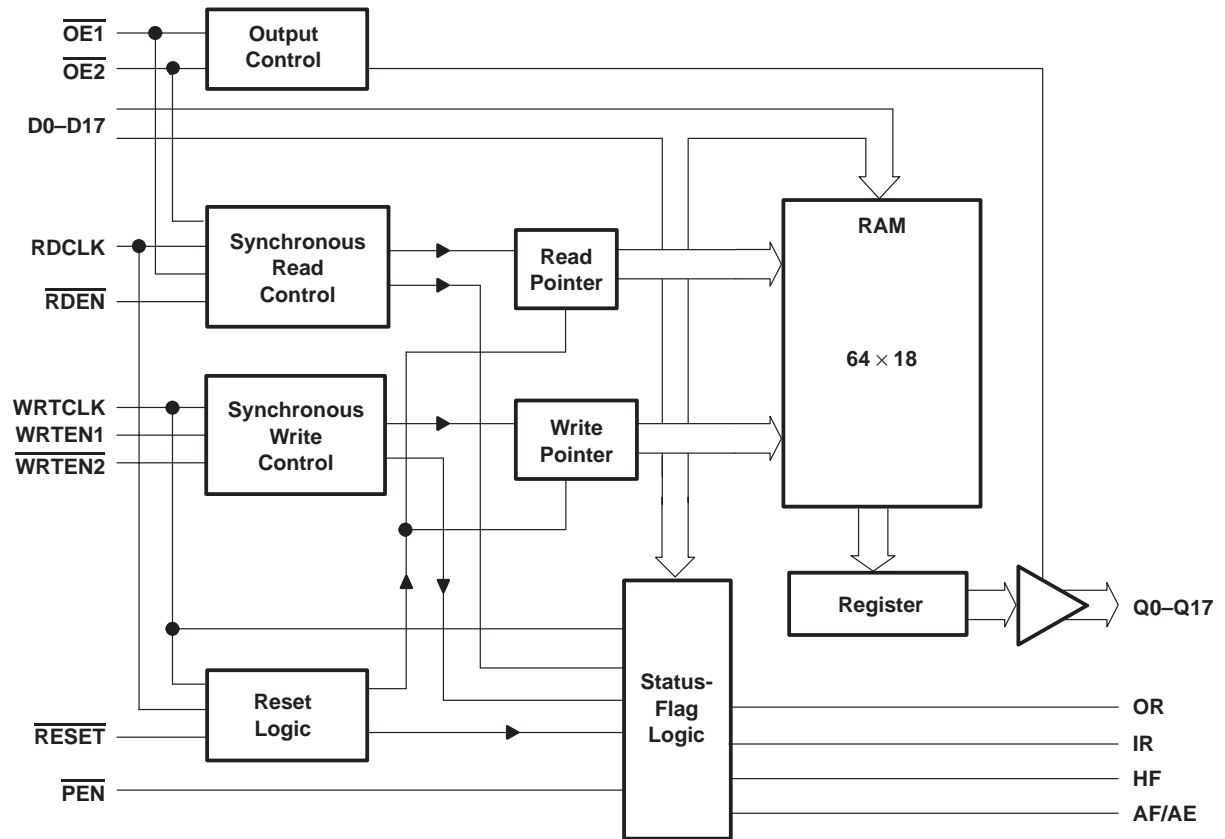

Terminal Functions

TERMINAL NAME	NO.	I/O	DESCRIPTION
AF/AE	24	O	Almost-full/almost-empty flag. Depth-offset values can be programmed for this flag, or the default value of 8 can be used for both the almost-empty offset (X) and the almost-full offset (Y). AF/AE is high when memory contains X or fewer words or (64 – Y) or more words. AF/AE is high after reset.
D0–D17	2–9, 11–12, 14–21	I	18-bit data input port
HF	22	O	Half-full flag. HF is high when the FIFO memory contains 32 or more words. HF is low after reset.
IR	28	O	Input-ready flag. IR is synchronized to the low-to-high transition of WRTCLK. When IR is low, the FIFO is full and writes are disabled. IR is low during reset and goes high on the second low-to-high transition of WRTCLK after reset.
$\overline{\text{OE1}}$ $\overline{\text{OE2}}$	56 30	I	Output enables. When $\overline{\text{OE1}}$, $\overline{\text{OE2}}$, and $\overline{\text{RDEN}}$ are low and OR is high, data is read from the FIFO on a low-to-high transition of RDCLK. When either $\overline{\text{OE1}}$ or $\overline{\text{OE2}}$ is high, reads are disabled and the data outputs are in the high-impedance state.
OR	29	O	Output-ready flag. OR is synchronized to the low-to-high transition of RDCLK. When OR is low, the FIFO is empty and reads are disabled. Ready data is present on Q0–Q17 when OR is high. OR is low during reset and goes high on the third low-to-high transition of RDCLK after the first word is loaded to empty memory.
$\overline{\text{PEN}}$	23	I	Program enable. After reset and before the first word is written to the FIFO, the binary value on D0–D7 is latched as an AF/AE offset value when $\overline{\text{PEN}}$ is low and WRTCLK is high.
Q0–Q17	33–34, 36–38, 40–43, 45–49, 51, 53–55	O	18-bit data output port. After the first valid write to empty memory, the first word is output on Q0–Q17 on the third rising edge of RDCLK. OR also is asserted high at this time to indicate ready data. When OR is low, the last word read from the FIFO is present on Q0–Q17.
RDCLK	32	I	Read clock. RDCLK is a continuous clock and can be asynchronous or coincident to WRTCLK. A low-to-high transition of RDCLK reads data from memory when $\overline{\text{OE1}}$, $\overline{\text{OE2}}$, and $\overline{\text{RDEN}}$ are low and OR is high. OR is synchronous to the low-to-high transition of RDCLK.
$\overline{\text{RDEN}}$	31	I	Read enable. When $\overline{\text{RDEN}}$, $\overline{\text{OE1}}$, and $\overline{\text{OE2}}$ are low and OR is high, data is read from the FIFO on the low-to-high transition of RDCLK.
$\overline{\text{RESET}}$	1	I	Reset. To reset the FIFO, four low-to-high transitions of RDCLK and four low-to-high transitions of WRTCLK must occur while $\overline{\text{RESET}}$ is low. This sets HF, IR, and OR low and AF/AE high.
WRTCLK	25	I	Write clock. WRTCLK is a continuous clock and can be asynchronous or coincident to RDCLK. A low-to-high transition of WRTCLK writes data to memory when $\overline{\text{WRTEN2}}$ is low, $\overline{\text{WRTEN1}}$ is high, and IR is high. IR is synchronous to the low-to-high transition of WRTCLK.
$\overline{\text{WRTEN1}}$ $\overline{\text{WRTEN2}}$	27 26	I	Write enables. When $\overline{\text{WRTEN1}}$ is high, $\overline{\text{WRTEN2}}$ is low, and IR is high, data is written to the FIFO on a low-to-high transition of WRTCLK.

LOW-POWER CLOCKED FIRST-IN, FIRST-OUT MEMORY

SCAS594A – OCTOBER 1997 – REVISED APRIL 1998

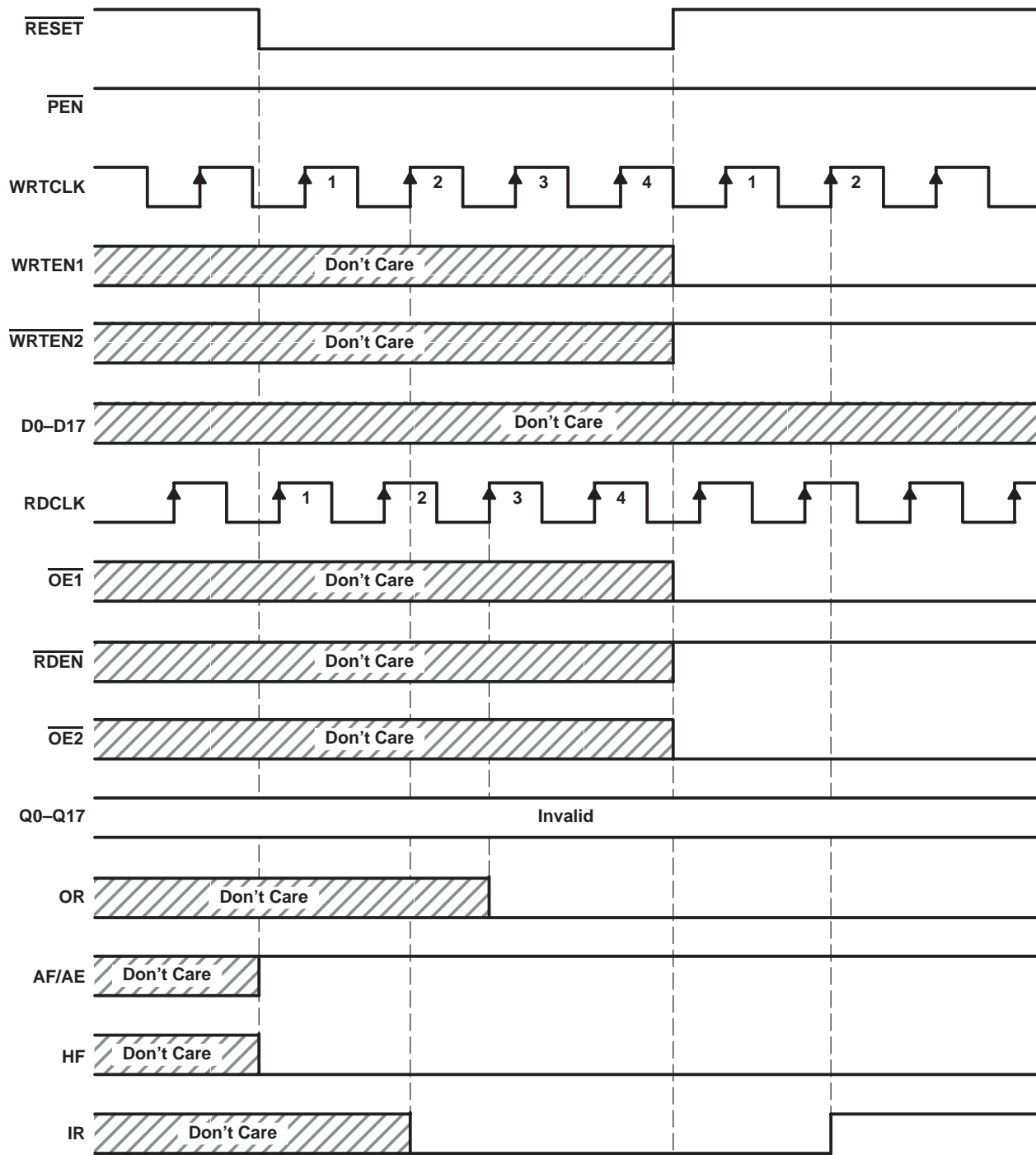

Define the AF/AE Flag Using the Default Value of X = Y = 8

Figure 1. Reset Cycle

SN74ALVC7813

64 × 18

LOW-POWER CLOCKED FIRST-IN, FIRST-OUT MEMORY

SCAS594A – OCTOBER 1997 – REVISED APRIL 1998

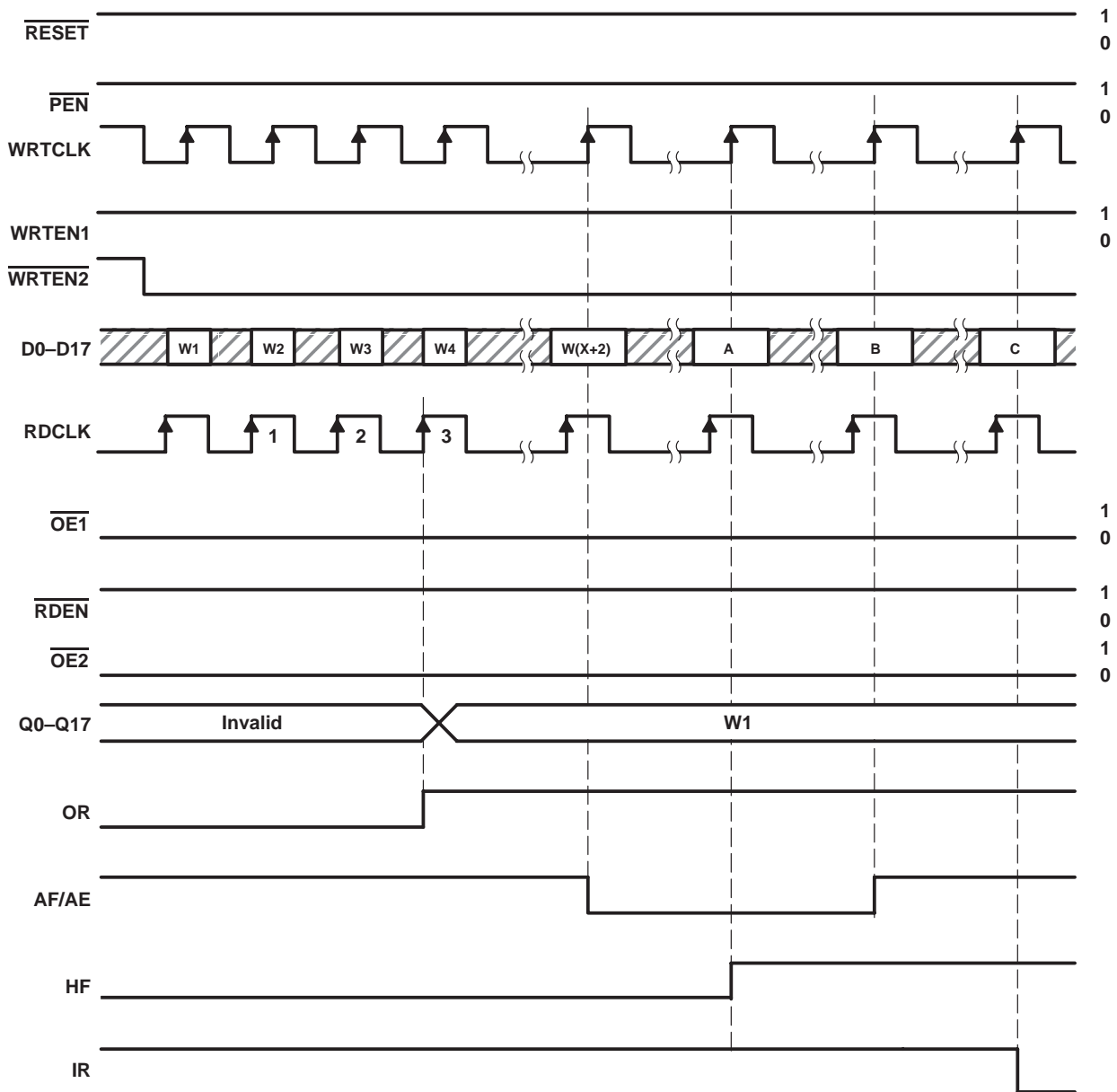

DATA-WORD NUMBER FOR FLAG TRANSITIONS

DEVICE	TRANSITION WORD		
	A	B	C
SN74ALVC7813	W33	W(65 - Y)	W65

Figure 2. FIFO Write

LOW-POWER CLOCKED FIRST-IN, FIRST-OUT MEMORY

SCAS594A – OCTOBER 1997 – REVISED APRIL 1998

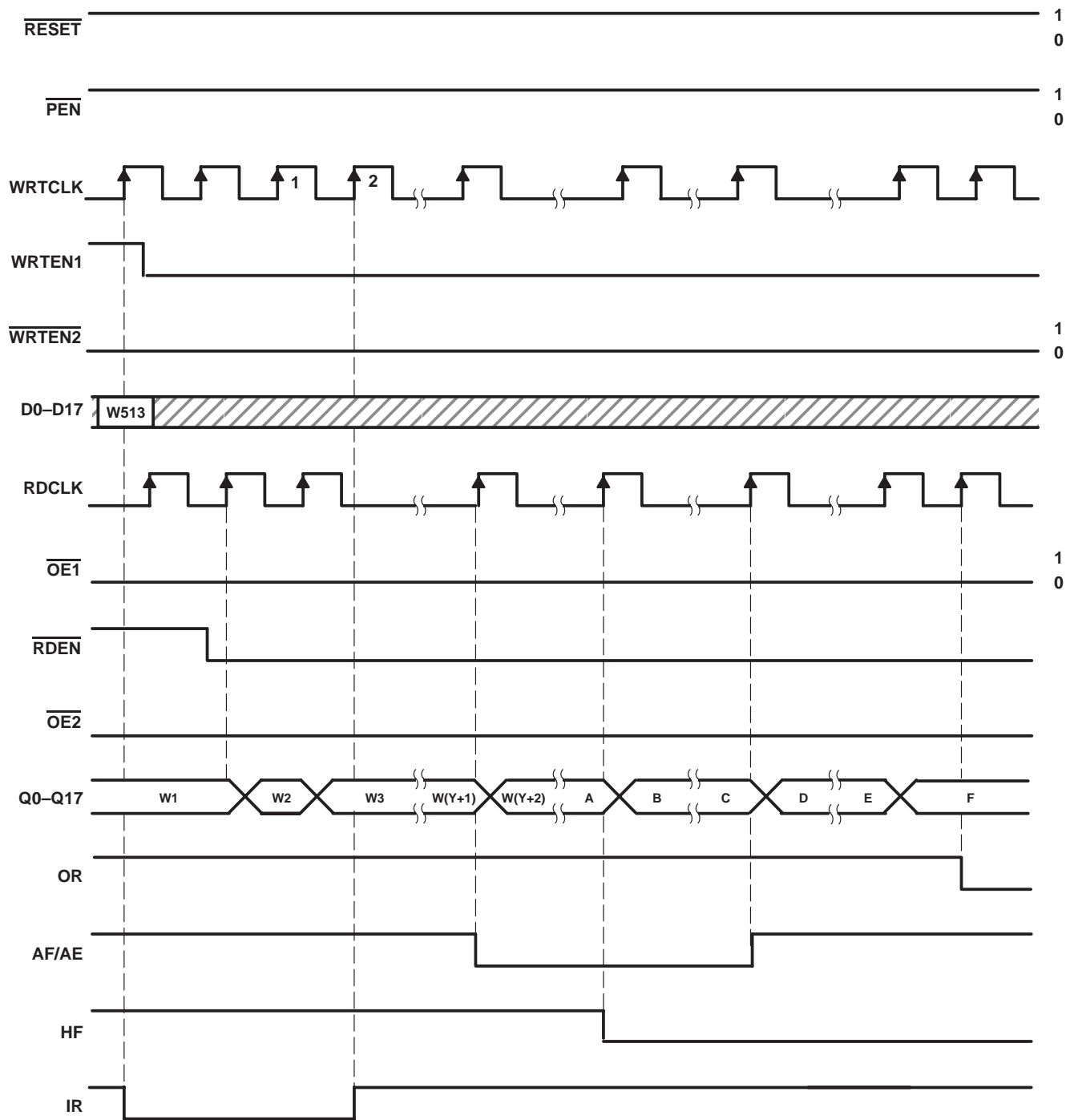

DATA-WORD NUMBERS FOR FLAG TRANSITIONS

DEVICE	TRANSITION WORD					
	A	B	C	D	E	F
SN74ALVC7813	W33	W34	W(64 - X)	W(65 - X)	64	65

Figure 3. FIFO Read

offset values for AF/AE

The AF/AE flag has two programmable limits: the almost-empty offset value (X) and the almost-full offset value (Y). They can be programmed after the FIFO is reset and before the first word is written to memory. If the offsets are not programmed, the default values of X = Y = 8 are used. The AF/AE flag is high when the FIFO contains X or fewer words or (64 – Y) or more words.

Program enable (\overline{PEN}) should be held high throughout the reset cycle. \overline{PEN} can be brought low only when IR is high. On the following low-to-high transition of WRTCLK, the binary value on D0–D7 is stored as the almost-empty offset value (X) and the almost-full offset value (Y). Holding \overline{PEN} low for another low-to-high transition of WRTCLK reprograms Y to the binary value on D0–D7 at the time of the second WRTCLK low-to-high transition. When the offsets are being programmed, writes to the FIFO memory are disabled, regardless of the state of the write enables (WRTEN1, WRTEN2). A maximum value of 63 can be programmed for either X or Y (see Figure 4). To use the default values of X = Y = 8, \overline{PEN} must be held high.

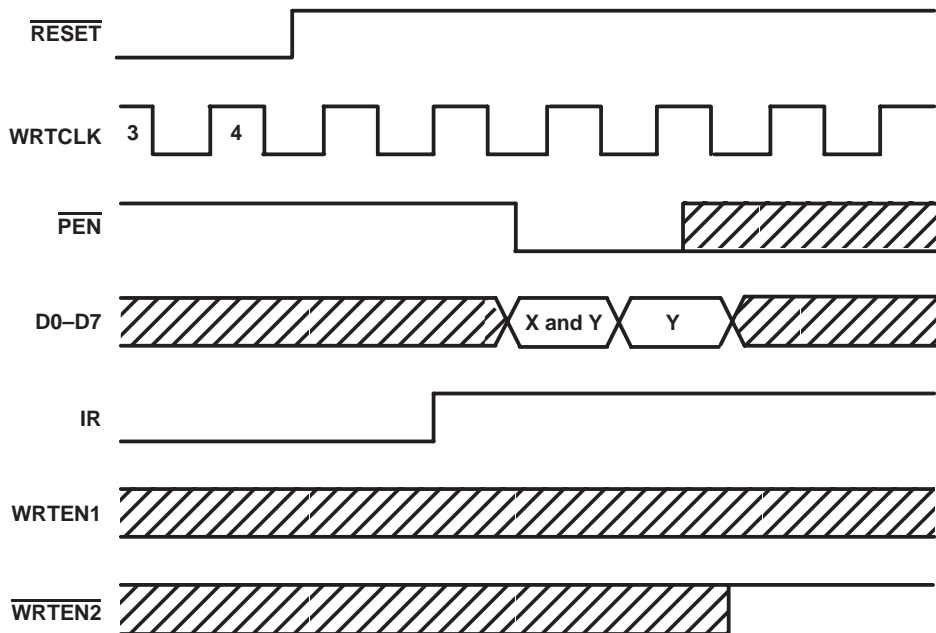

Figure 4. Programming X and Y Separately

absolute maximum ratings over operating free-air temperature range (unless otherwise noted)†

Supply voltage range, V_{CC}	–0.5 V to 4.6 V
Input voltage range, V_I (see Note 1)	–0.5 V to 4.6 V
Output voltage range, V_O (see Notes 1 and 2)	–0.5 V to $V_{CC} + 0.5$ V
Voltage range applied to a disabled 3-state output	–0.5 V to 3.6 V
Input clamp current, I_{IK} ($V_I < 0$)	–50 mA
Output clamp current, I_{OK} ($V_O < 0$ or $V_O > V_{CC}$)	±50 mA
Continuous output current, I_O ($V_O = 0$ to V_{CC})	±50 mA
Continuous current through V_{CC} or GND	±100 mA
Package thermal impedance, θ_{JA} (see Note 3)	74°C/W
Storage temperature range, T_{stg}	–65°C to 150°C

† Stresses beyond those listed under “absolute maximum ratings” may cause permanent damage to the device. These are stress ratings only, and functional operation of the device at these or any other conditions beyond those indicated under “recommended operating conditions” is not implied. Exposure to absolute-maximum-rated conditions for extended periods may affect device reliability.

- NOTES: 1. The input and output voltage ratings can be exceeded if the input and output clamp current ratings are observed.
 2. This value is limited to 4.6 V maximum.
 3. The package thermal impedance is calculated in accordance with JESD 51.

recommended operating conditions

		'ALVC7813-20		'ALVC7813-25		'ALVC7813-40		UNIT
		MIN	MAX	MIN	MAX	MIN	MAX	
V_{CC}	Supply voltage	3	3.6	3	3.6	3	3.6	V
V_{IH}	High-level input voltage	2		2		2		V
V_{IL}	Low-level input voltage		0.8		0.8		0.8	V
I_{OH}	High-level output current, Q outputs, flags	$V_{CC} = 3$ V		–8	–8	–8		mA
I_{OL}	Low-level output current, Q outputs, flags	$V_{CC} = 3$ V		16	16	16		mA
T_A	Operating free-air temperature	0	70	0	70	0	70	°C

electrical characteristics over recommended operating free-air temperature range (unless otherwise noted)

PARAMETER		TEST CONDITIONS		MIN	TYP‡	MAX	UNIT
V_{IK}		$V_{CC} = 3$ V,	$I_{IK} = -18$ mA			–1.2	V
V_{OH}	Flags, Q outputs	$V_{CC} = 3$ V to 3.6 V,	$I_{OH} = -100$ μ A	$V_{CC} - 0.2$			V
		$V_{CC} = 3$ V,	$I_{OH} = -8$ mA	2.4			
V_{OL}	Flags, Q outputs	$V_{CC} = 3$ V to 3.6 V,	$I_{OL} = 100$ μ A			0.2	V
	Flags	$V_{CC} = 3$ V,	$I_{OL} = 8$ mA			0.4	
	Q outputs	$V_{CC} = 3$ V,	$I_{OL} = 16$ mA			0.55	
I_I		$V_{CC} = 3.6$ V,	$V_I = V_{CC}$ or GND			±5	μ A
I_{OZ}		$V_{CC} = 3.6$ V,	$V_O = V_{CC}$ or GND			±10	μ A
I_{CC}		$V_I = V_{CC}$ or 0				40	μ A
ΔI_{CC}^{\S}		$V_{CC} = 3.6$ V, One input at $V_{CC} - 0.6$ V, Other inputs at V_{CC} or GND				500	μ A
C_i		$V_{CC} = 3.3$ V,	$V_I = V_{CC}$ or GND			2.5	pF
C_o		$V_{CC} = 3.3$ V,	$V_O = V_{CC}$ or GND			5.5	pF

‡ All typical values are at $V_{CC} = 3.3$ V, $T_A = 25^\circ\text{C}$.

§ This is the supply current for each input that is at one of the specified TTL voltage levels rather than 0 V or V_{CC} .

timing requirements over recommended operating conditions (see Figures 1 through 5)

		'ALVC7813-20		'ALVC7813-25		'ALVC7813-40		UNIT
		MIN	MAX	MIN	MAX	MIN	MAX	
f_{clock}	Clock frequency	50		40		25		MHz
t_w	Pulse duration	D0–D17 high or low	9	10	14			ns
		WRTCLK high or low	7	8	12			
		RDCLK high or low	7	8	12			
		$\overline{\text{PEN}}$ low	9	9	12			
		WRTEN1 high, $\overline{\text{WRTEN2}}$ low	8	8	12			
		$\overline{\text{OE1}}$, $\overline{\text{OE2}}$ low	9	9	12			
		$\overline{\text{RDEN}}$ low	8	8	12			
t_{su}	Setup time	D0–D17 before WRTCLK \uparrow	5	5	5			ns
		WRTEN1, $\overline{\text{WRTEN2}}$ before WRTCLK \uparrow	5	5	5			
		$\overline{\text{OE1}}$, $\overline{\text{OE2}}$ before RDCLK \uparrow	5	6	6			
		$\overline{\text{RDEN}}$ before RDCLK \uparrow	5	5	7			
		Reset: $\overline{\text{RESET}}$ low before first WRTCLK \uparrow and RDCLK \uparrow	6	6	6			
		$\overline{\text{PEN}}$ before WRTCLK \uparrow	6	6	6			
t_h	Hold time	D0–D17 after WRTCLK \uparrow	0	0	0			ns
		WRTEN1, $\overline{\text{WRTEN2}}$ after WRTCLK \uparrow	0	0	0			
		$\overline{\text{OE1}}$, $\overline{\text{OE2}}$, $\overline{\text{RDEN}}$ after RDCLK \uparrow	0	0	0			
		Reset: $\overline{\text{RESET}}$ low after fourth WRTCLK \uparrow and RDCLK \uparrow	2	2	2			
		$\overline{\text{PEN}}$ low after WRTCLK \uparrow	2	2	2			

† To permit the clock pulse to be utilized for reset purposes

switching characteristics over recommended ranges of supply voltage and operating free-air temperature, $C_L = 50$ pF (unless otherwise noted) (see Figure 5)

PARAMETER	FROM (OUTPUT)	TO (INPUT)	'ALVC7813-20		'ALVC7813-25		'ALVC7813-40		UNIT
			MIN	MAX	MIN	MAX	MIN	MAX	
f_{max}	WRTCLK or RDCLK		50		40		25		MHz
t_{pd}	RDCLK \uparrow	Any Q	4	13	4	15	4	20	ns
	WRTCLK \uparrow	IR	3	11	3	13	3	15	
	RDCLK \uparrow	OR	3	11	3	13	3	15	
	WRTCLK \uparrow	AF/AE	7	19	7	21	7	23	
	RDCLK \uparrow		7	19	7	21	7	23	
t_{PLH}	WRTCLK \uparrow	HF	7	17	7	19	7	21	ns
t_{PHL}	RDCLK \uparrow	HF	7	18	7	20	7	22	ns
t_{PLH}	$\overline{\text{RESET}}$ low	AF/AE	2	11	2	13	2	15	ns
t_{PHL}	$\overline{\text{RESET}}$ low	HF	2	12	2	14	2	16	ns
t_{en}	$\overline{\text{OE1}}$, $\overline{\text{OE2}}$	Any Q	2	11	2	11	2	14	ns
t_{dis}	$\overline{\text{OE1}}$, $\overline{\text{OE2}}$	Any Q	2	11	2	14	2	14	ns

operating characteristics, $V_{\text{CC}} = 3.3$ V, $T_A = 25^\circ\text{C}$

PARAMETER		TEST CONDITIONS	TYP	UNIT
C_{pd}	Power dissipation capacitance	Outputs enabled $C_L = 50$ pF, $f = 5$ MHz	53	pF

PARAMETER MEASUREMENT INFORMATION

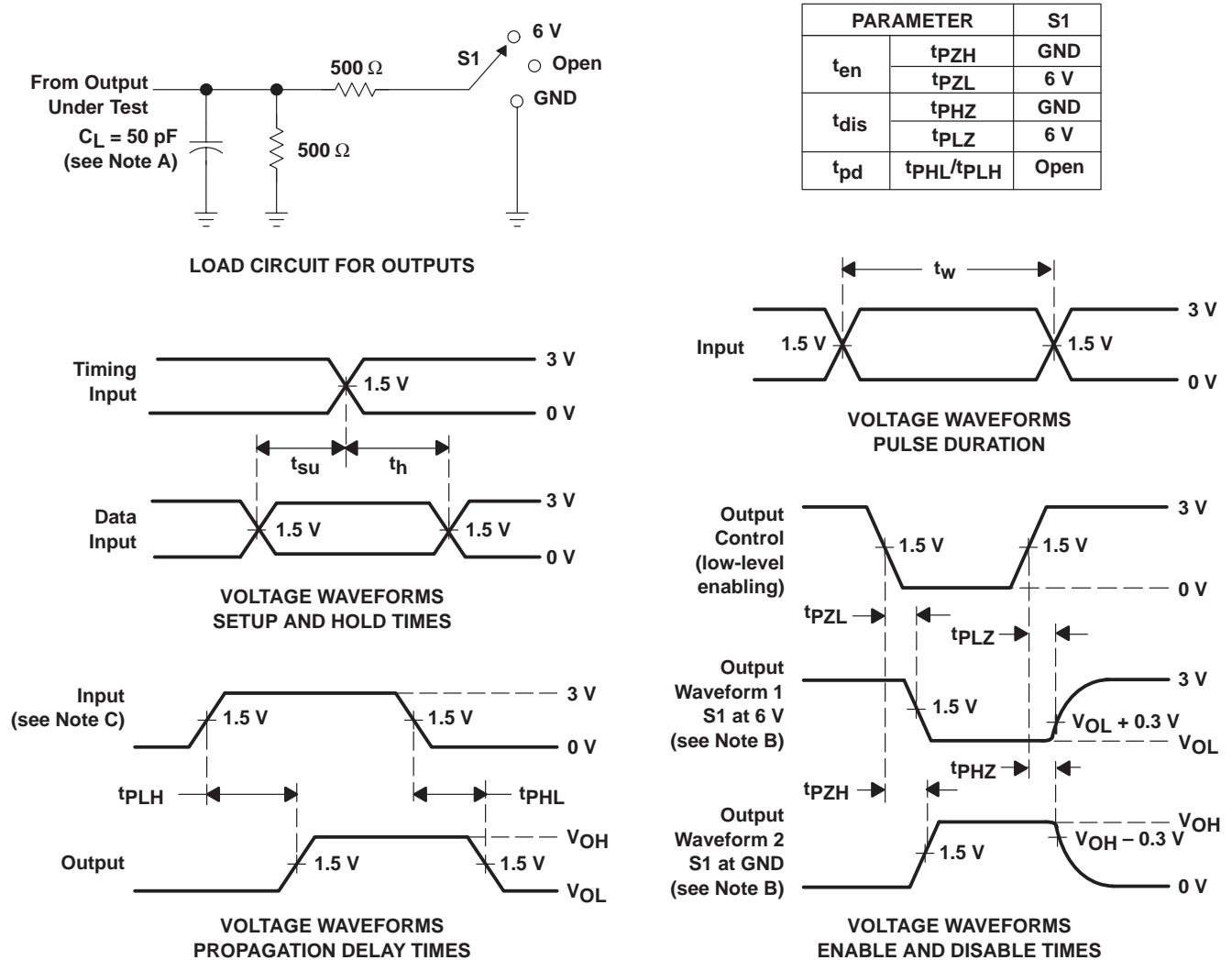

- NOTES: A. C_L includes probe and jig capacitance.
 B. Waveform 1 is for an output with internal conditions such that the output is low except when disabled by the output control. Waveform 2 is for an output with internal conditions such that the output is high except when disabled by the output control.
 C. All input pulses are supplied by generators having the following characteristics: $PRR \leq 10 \text{ MHz}$, $Z_O = 50 \Omega$, $t_r \leq 2.5 \text{ ns}$, $t_f \leq 2.5 \text{ ns}$.

Figure 5. Standard CMOS Outputs (FULL, EMPTY, HF, AF/AE)

TYPICAL CHARACTERISTICS

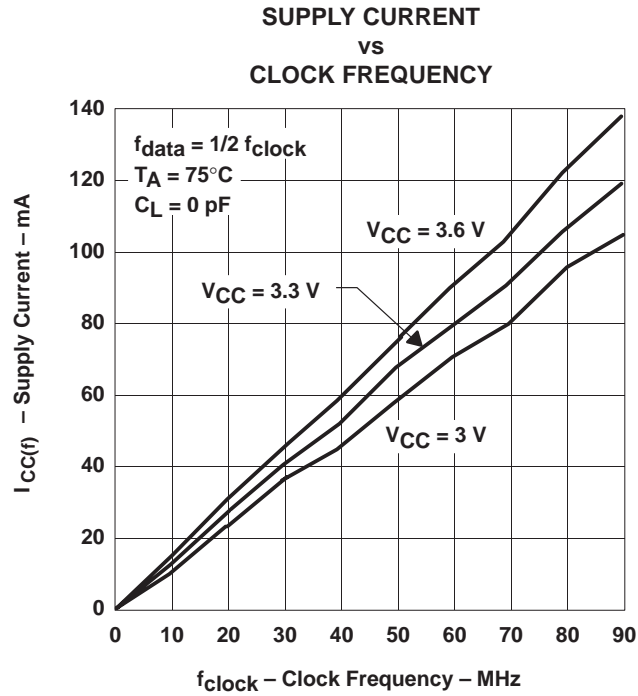

Figure 6

APPLICATION INFORMATION

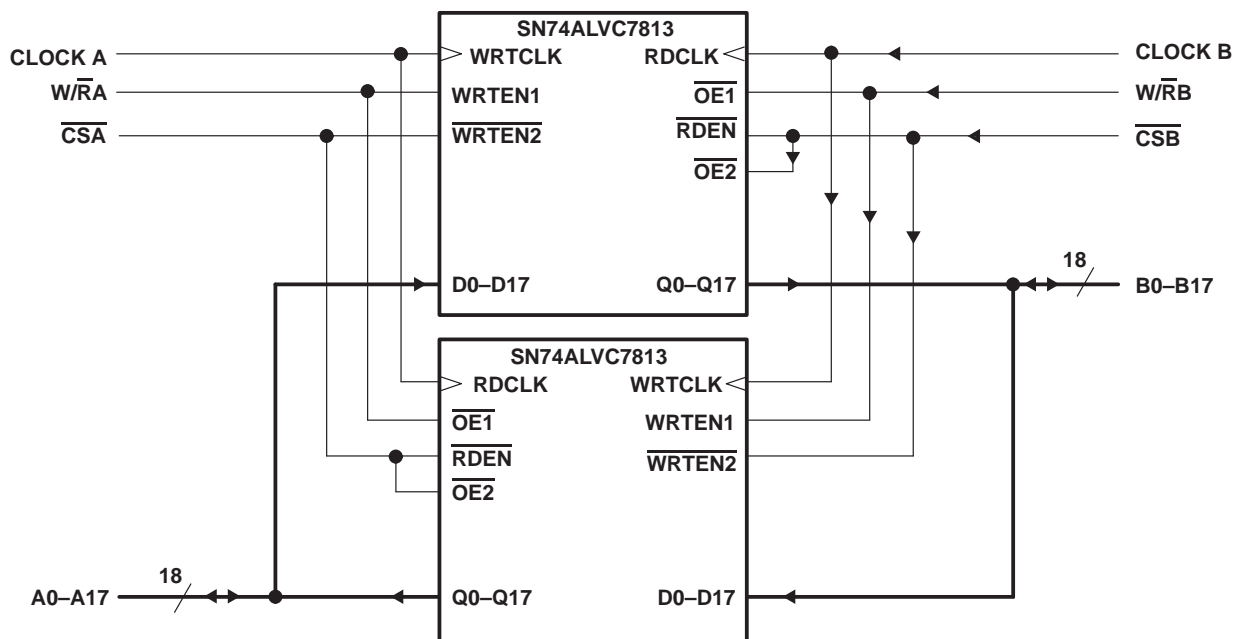

Figure 7. Bidirectional Configuration

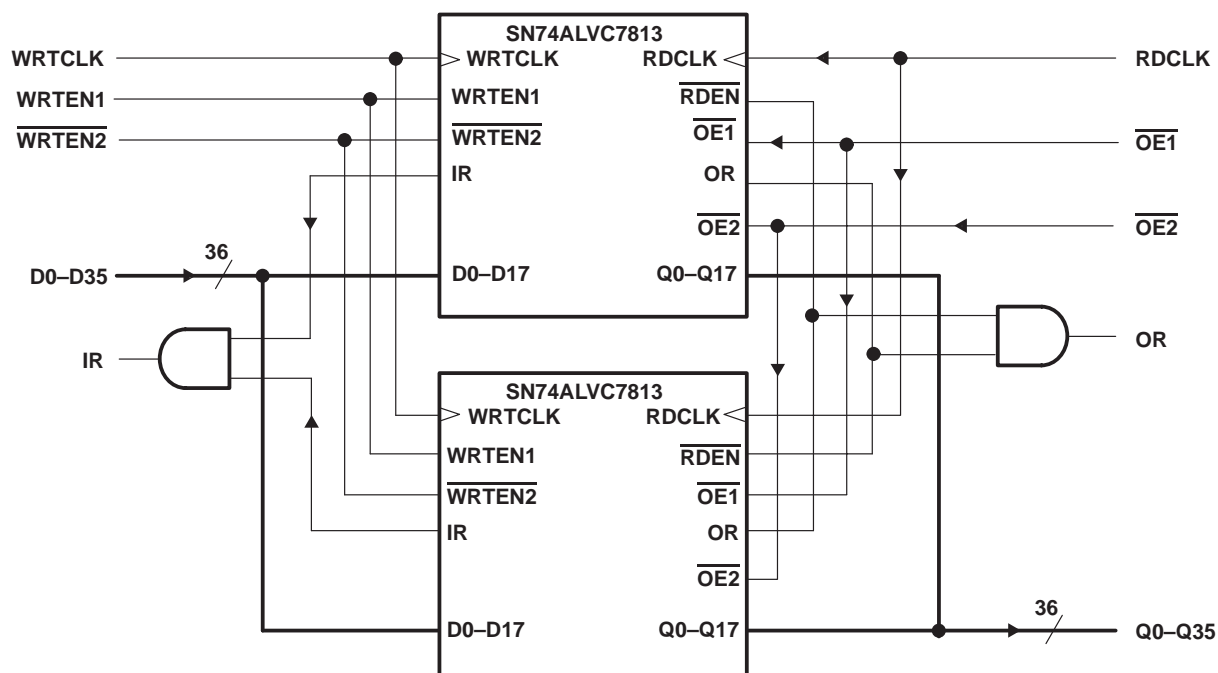

Figure 8. Word-Width Expansion: 64 × 36 Bits

IMPORTANT NOTICE

Texas Instruments and its subsidiaries (TI) reserve the right to make changes to their products or to discontinue any product or service without notice, and advise customers to obtain the latest version of relevant information to verify, before placing orders, that information being relied on is current and complete. All products are sold subject to the terms and conditions of sale supplied at the time of order acknowledgement, including those pertaining to warranty, patent infringement, and limitation of liability.

TI warrants performance of its semiconductor products to the specifications applicable at the time of sale in accordance with TI's standard warranty. Testing and other quality control techniques are utilized to the extent TI deems necessary to support this warranty. Specific testing of all parameters of each device is not necessarily performed, except those mandated by government requirements.

CERTAIN APPLICATIONS USING SEMICONDUCTOR PRODUCTS MAY INVOLVE POTENTIAL RISKS OF DEATH, PERSONAL INJURY, OR SEVERE PROPERTY OR ENVIRONMENTAL DAMAGE ("CRITICAL APPLICATIONS"). TI SEMICONDUCTOR PRODUCTS ARE NOT DESIGNED, AUTHORIZED, OR WARRANTED TO BE SUITABLE FOR USE IN LIFE-SUPPORT DEVICES OR SYSTEMS OR OTHER CRITICAL APPLICATIONS. INCLUSION OF TI PRODUCTS IN SUCH APPLICATIONS IS UNDERSTOOD TO BE FULLY AT THE CUSTOMER'S RISK.

In order to minimize risks associated with the customer's applications, adequate design and operating safeguards must be provided by the customer to minimize inherent or procedural hazards.

TI assumes no liability for applications assistance or customer product design. TI does not warrant or represent that any license, either express or implied, is granted under any patent right, copyright, mask work right, or other intellectual property right of TI covering or relating to any combination, machine, or process in which such semiconductor products or services might be or are used. TI's publication of information regarding any third party's products or services does not constitute TI's approval, warranty or endorsement thereof.

Looking for pricing, stock, or lifecycle information?

Click below to explore more details on WIN SOURCE:

 [View SN74ALVC7813-40DL on WIN SOURCE](#)

 [Texas Instruments](#) Information

Optimize Your Supply Chain with WIN SOURCE Solutions

-  Global Sourcing Solution
-  Obsolete Management
-  Cost Control Management
-  Shortage Management
-  Alternative Solution
-  Excess Inventory Management