



**THE DATASHEET OF
CY8C24894-24LFXI**



1. Features

- XRES Pin to Support In-System Serial Programming (ISSP) and External Reset Control in CY8C24894
- Powerful Harvard Architecture Processor
 - M8C Processor Speeds to 24 MHz
 - Two 8x8 Multiply, 32-Bit Accumulate
 - Low Power at High Speed
 - 3V to 5.25V Operating Voltage
 - Industrial Temperature Range: -40°C to +85°C
 - USB Temperature Range: -10°C to +85°C
- Advanced Peripherals (PSoC[®] Blocks)
 - 6 Rail-to-Rail Analog PSoC Blocks Provide:
 - Up to 14-Bit ADCs
 - Up to 9-Bit DACs
 - Programmable Gain Amplifiers
 - Programmable Filters and Comparators
 - Four Digital PSoC Blocks Provide:
 - 8 to 32-Bit Timers, Counters, and PWMs
 - CRC and PRS Modules
 - Full-Duplex UART
 - Multiple SPI™ Masters or Slaves
 - Connectable to all GPI/O Pins
 - Complex Peripherals by Combining Blocks
 - Capacitive Sensing Application Capability
- Full Speed USB (12 Mbps)
 - Four Uni-Directional Endpoints
 - One Bi-Directional Control Endpoint
 - USB 2.0 Compliant
 - Dedicated 256 Byte Buffer
 - No External Crystal Required
- Flexible On-Chip Memory
 - 16K Flash Program Storage 50,000 Erase and Write Cycles
 - 1K SRAM Data Storage
 - In-System Serial Programming (ISSP)
 - Partial Flash Updates
 - Flexible Protection Modes
 - EEPROM Emulation in Flash
- Programmable Pin Configurations
 - 25 mA Sink, 10 mA Drive on all GPI/O
 - Pull Up, Pull Down, High Z, Strong, or Open Drain Drive Modes on all GPI/O
 - Up to 48 Analog Inputs on GPI/O
 - Two 33 mA Analog Outputs on GPI/O
 - Configurable Interrupt on all GPI/O
- Precision, Programmable Clocking
 - Internal ±4% 24 and 48 MHz Oscillator
 - Internal Oscillator for Watchdog and Sleep
 - 0.25% Accuracy for USB with no External Components
- Additional System Resources
 - I²C Slave, Master, and Multi-Master to 400 kHz
 - Watchdog and Sleep Timers
 - User Configurable Low Voltage Detection

2. Logic Block Diagram

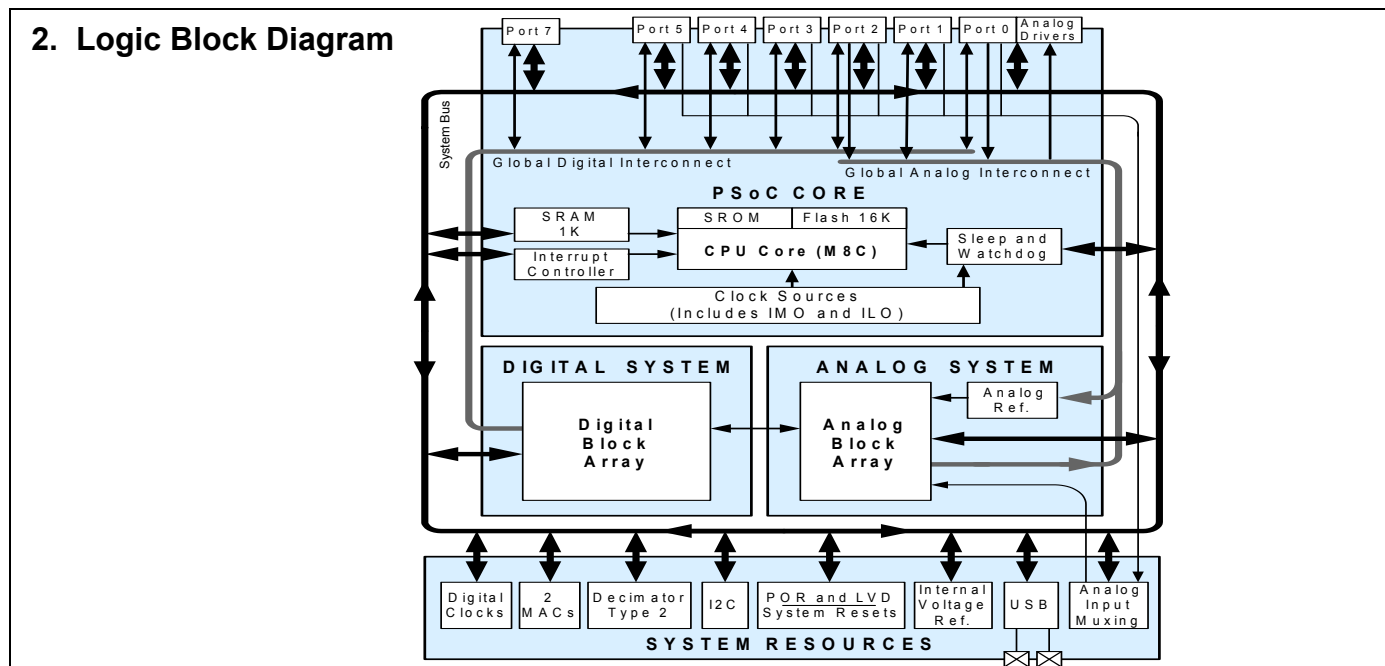

2. PSoC Functional Overview

The PSoC family consists of many programmable system-on-chips with On-Chip Controller devices. All PSoC family devices are designed to replace traditional MCUs, system ICs, and the numerous discrete components that surround them. The PSoC CY8C24x94 devices are unique members of the PSoC family because it includes a full featured, full speed (12 Mbps) USB port. Configurable analog, digital, and interconnect circuitry enable a high level of integration in a host of industrial, consumer, and communication applications.

This architecture enables the user to create customized peripheral configurations that match the requirements of each individual application. Additionally, a fast CPU, Flash program memory, SRAM data memory, and configurable I/O are included in a range of convenient pinouts and packages.

The PSoC architecture, as illustrated on the left, is comprised of four main areas: PSoC Core, Digital System, Analog System, and System Resources including a full speed USB port. Configurable global busing enables all the device resources to be combined into a complete custom system. The PSoC CY8C24x94 devices can have up to seven I/O ports that connect to the global digital and analog interconnects, providing access to 4 digital blocks and 6 analog blocks.

2.1 The PSoC Core

The PSoC Core is a powerful engine that supports a rich feature set. The core includes a CPU, memory, clocks, and configurable GPI/O (General Purpose I/O).

The M8C CPU core is a powerful processor with speeds up to 24 MHz, providing a four MIPS 8-bit Harvard architecture microprocessor. The CPU uses an interrupt controller with up to 20 vectors, to simplify programming of real time embedded events. Program execution is timed and protected using the included Sleep and Watch Dog Timers (WDT).

Memory encompasses 16K of Flash for program storage, 1K of SRAM for data storage, and up to 2K of EEPROM emulated using the Flash. Program Flash uses four protection levels on blocks of 64 bytes, allowing customized software IP protection.

The PSoC device incorporates flexible internal clock generators, including a 24 MHz IMO (internal main oscillator) accurate to 8% over temperature and voltage. The 24 MHz IMO can also be doubled to 48 MHz for use by the digital system. A low power 32 kHz ILO (internal low speed oscillator) is provided for the Sleep timer and WDT. The clocks, together with programmable clock dividers (as a System Resource), provide the flexibility to integrate almost any timing requirement into the PSoC device. In USB systems, the IMO self tunes to $\pm 0.25\%$ accuracy for USB communication.

PSoC GPIOs provide connection to the CPU, digital and analog resources of the device. Each pin's drive mode may be selected from eight options, allowing great flexibility in external interfacing. Every pin is also capable of generating a system interrupt on high level, low level, and change from last read.

2.2 The Digital System

The Digital System is composed of four digital PSoC blocks. Each block is an 8-bit resource used alone or combined with other blocks to form 8, 16, 24, and 32-bit peripherals, which are called user module references.

Figure 2-1. Digital System Block Diagram

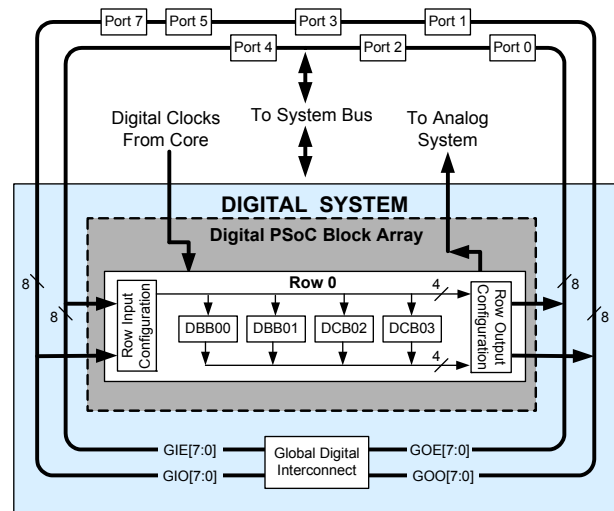

Digital peripheral configurations include the following:

- Full Speed USB (12 Mbps)
- PWMs (8 to 32 bit)
- PWMs with Dead band (8 to 24 bit)
- Counters (8 to 32 bit)
- Timers (8 to 32 bit)
- UART 8 bit with selectable parity
- SPI master and slave
- I2C slave and multi-master
- Cyclical Redundancy Checker/Generator (8 to 32 bit)
- IrDA
- Pseudo Random Sequence Generators (8 to 32 bit)

The digital blocks are connected to any GPI/O through a series of global buses that can route any signal to any pin. The buses also enable signal multiplexing and performing logic operations. This configurability frees the designs from the constraints of a fixed peripheral controller.

Digital blocks are provided in rows of four, where the number of blocks varies by PSoC device family. This enables you the optimum choice of system resources for your application. Family resources are shown in [Table 2-1](#) on page 4.

2.3 The Analog System

The Analog System is composed of 6 configurable blocks, each comprised of an opamp circuit allowing the creation of complex analog signal flows. Analog peripherals are very flexible and can be customized to support specific application requirements. Some of the more common PSoC analog functions (most available as user modules) are as follows.

- Analog-to-digital converters (up to 2, with 6 to 14-bit resolution, selectable as Incremental, Delta Sigma, and SAR)
- Filters (2 and 4 pole band-pass, low-pass, and notch)
- Amplifiers (up to 2, with selectable gain to 48x)
- Instrumentation amplifiers (1 with selectable gain to 93x)
- Comparators (up to 2, with 16 selectable thresholds)
- DACs (up to 2, with 6- to 9-bit resolution)
- Multiplying DACs (up to 2, with 6- to 9-bit resolution)
- High current output drivers (two with 30 mA drive as a PSoC Core Resource)
- 1.3V reference (as a System Resource)
- DTMF Dialer
- Modulators
- Correlators
- Peak Detectors
- Many other topologies possible

Analog blocks are arranged in a column of three, which includes one CT (Continuous Time) and two SC (Switched Capacitor) blocks, as shown in Figure 2-2.

Figure 2-2. Analog System Block Diagram

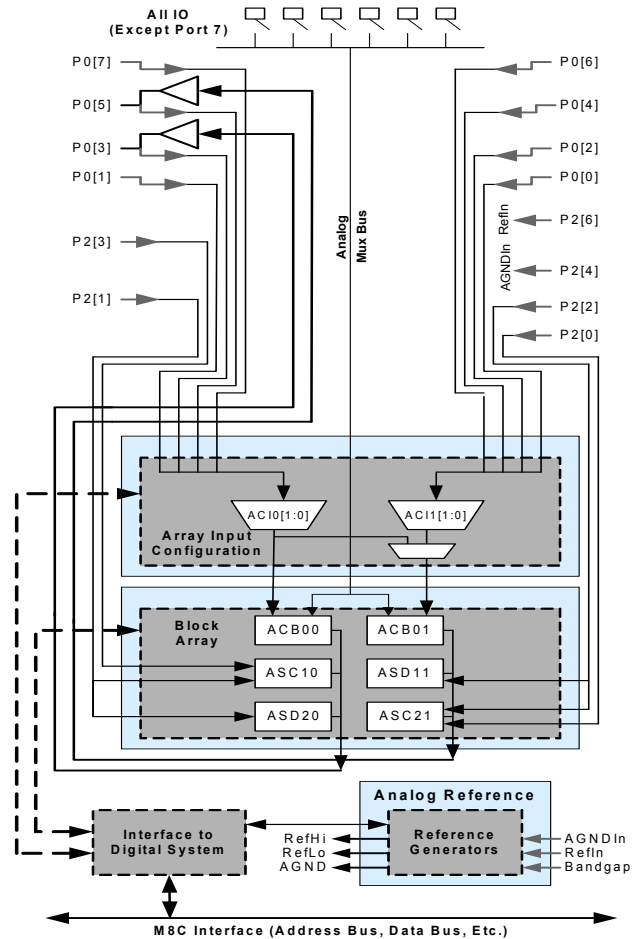

2.3.1 The Analog Multiplexer System

The Analog Mux Bus can connect to every GPIO pin in ports 0-5. Pins are connected to the bus individually or in any combination. The bus also connects to the analog system for analysis with comparators and analog-to-digital converters. It is split into two sections for simultaneous dual-channel processing. An additional 8:1 analog input multiplexer provides a second path to bring Port 0 pins to the analog array.

Switch control logic enables selected pins to precharge continuously under hardware control. This enables capacitive measurement for applications such as touch sensing. Other multiplexer applications include:

- Track pad, finger sensing.
- Chip-wide mux that enables analog input from up to 48 I/O pins.
- Crosspoint connection between any I/O pin combinations.

When designing capacitive sensing applications, refer to the latest signal-to-noise signal level requirements Application Notes, which are found under <http://www.cypress.com> > Design Resources > Application Notes. In general, and unless otherwise noted in the relevant Application Notes, the minimum signal-to-noise ratio (SNR) for CapSense applications is 5:1.

2.4 Additional System Resources

System Resources, provide additional capability useful to complete systems. Additional resources include a multiplier, decimator, low voltage detection, and power on reset. Brief statements describing the merits of each resource follow.

- Full Speed USB (12 Mbps) with 5 configurable endpoints and 256 bytes of RAM. No external components required except two series resistors. Wider than commercial temperature USB operation (-10°C to +85°C).
- Digital clock dividers provide three customizable clock frequencies for use in applications. The clocks can be routed to both the digital and analog systems. Additional clocks are generated using digital PSoC blocks as clock dividers.
- Two multiply accumulates (MACs) provide fast 8-bit multipliers with 32-bit accumulate, to assist in both general math and digital filters.
- Decimator provides a custom hardware filter for digital signal processing applications including creation of Delta Sigma ADCs.
- The I2C module provides 100 and 400 kHz communication over two wires. Slave, master, multi-master are supported.
- Low Voltage Detection (LVD) interrupts signal the application of falling voltage levels, while the advanced POR (Power On Reset) circuit eliminates the need for a system supervisor.
- An internal 1.3V reference provides an absolute reference for the analog system, including ADCs and DACs.
- Versatile analog multiplexer system.

2.5 PSoC Device Characteristics

Depending on your PSoC device characteristics, the digital and analog systems can have 16, 8, or 4 digital blocks and 12, 6, or 4 analog blocks. The following table lists the resources available for specific PSoC device groups. The device covered by this data sheet is shown in the highlighted row of the table

Table 2-1. PSoC Device Characteristics

PSoC Part Number	Digital I/O	Digital Rows	Digital Blocks	Analog Inputs	Analog Outputs	Analog Columns	Analog Blocks	SRAM Size	Flash Size
CY8C29x66	up to 64	4	16	12	4	4	12	2K	32K
CY8C27x43	up to 44	2	8	12	4	4	12	256 Bytes	16K
CY8C24x94	56	1	4	48	2	2	6	1K	16K
CY8C24x23A	up to 24	1	4	12	2	2	6	256 Bytes	4K
CY8C21x34	up to 28	1	4	28	0	2	4	512 Bytes	8K
CY8C21x23	16	1	4	8	0	2	4	256 Bytes	4K
CY8C20x34	up to 28	0	0	28	0	0	3	512 Bytes	8K

3. Getting Started

The quickest way to understand PSoC silicon is to read this data sheet and then use the PSoC Designer Integrated Development Environment (IDE). This data sheet is an overview of the PSoC integrated circuit and presents specific pin, register, and electrical specifications.

For in depth information, along with detailed programming information, see the PSoC® Programmable System-on-Chip Technical Reference Manual for CY8C28xxx PSoC devices.

For up-to-date ordering, packaging, and electrical specification information, see the latest PSoC device data sheets on the web at www.cypress.com/psoc.

3.1 Application Notes

Application notes are an excellent introduction to the wide variety of possible PSoC designs. They are located here: www.cypress.com/psoc. Select Application Notes under the Documentation tab.

3.2 Development Kits

PSoC Development Kits are available online from Cypress at www.cypress.com/shop and through a growing number of regional and global distributors, which include Arrow, Avnet, Digi-Key, Farnell, Future Electronics, and Newark.

3.3 Training

Free PSoC technical training (on demand, webinars, and workshops) is available online at www.cypress.com/training. The training covers a wide variety of topics and skill levels to assist you in your designs.

3.4 CyPros Consultants

Certified PSoC Consultants offer everything from technical assistance to completed PSoC designs. To contact or become a PSoC Consultant go to www.cypress.com/cypros.

3.5 Solutions Library

Visit our growing library of solution focused designs at www.cypress.com/solutions. Here you can find various application designs that include firmware and hardware design files that enable you to complete your designs quickly.

3.6 Technical Support

For assistance with technical issues, search KnowledgeBase articles and forums at www.cypress.com/support. If you cannot find an answer to your question, call technical support at 1-800-541-4736.

4. Development Tools

PSoC Designer is a Microsoft® Windows-based, integrated development environment for the Programmable System-on-Chip (PSoC) devices. The PSoC Designer IDE runs on Windows XP or Windows Vista.

This system provides design database management by project, an integrated debugger with In-Circuit Emulator, in-system programming support, and built-in support for third-party assemblers and C compilers.

PSoC Designer also supports C language compilers developed specifically for the devices in the PSoC family.

4.1 PSoC Designer Software Subsystems

4.1.1 System-Level View

A drag-and-drop visual embedded system design environment based on PSoC Express. In the system level view you create a model of your system inputs, outputs, and communication interfaces. You define when and how an output device changes state based upon any or all other system devices. Based upon the design, PSoC Designer automatically selects one or more PSoC Mixed-Signal Controllers that match your system requirements.

PSoC Designer generates all embedded code, then compiles and links it into a programming file for a specific PSoC device.

4.1.2 Chip-Level View

The chip-level view is a more traditional integrated development environment (IDE) based on PSoC Designer 4.4. Choose a base device to work with and then select different onboard analog and digital components called user modules that use the PSoC blocks. Examples of user modules are ADCs, DACs, Amplifiers, and Filters. Configure the user modules for your chosen application and connect them to each other and to the proper pins. Then generate your project. This prepopulates your project with APIs and libraries that you can use to program your application.

The device editor also supports easy development of multiple configurations and dynamic reconfiguration. Dynamic configuration enables changing configurations at run time.

4.1.3 Hybrid Designs

You can begin in the system-level view, allow it to choose and configure your user modules, routing, and generate code, then switch to the chip-level view to gain complete control over on-chip resources. All views of the project share a common code editor, builder, and common debug, emulation, and programming tools.

4.1.4 Code Generation Tools

PSoC Designer supports multiple third party C compilers and assemblers. The code generation tools work seamlessly within the PSoC Designer interface and have been tested with a full range of debugging tools. The choice is yours.

Assemblers. The assemblers allow assembly code to merge seamlessly with C code. Link libraries automatically use absolute addressing or are compiled in relative mode, and linked with other software modules to get absolute addressing.

C Language Compilers. C language compilers are available that support the PSoC family of devices. The products allow you to create complete C programs for the PSoC family devices.

The optimizing C compilers provide all the features of C tailored to the PSoC architecture. They come complete with embedded libraries providing port and bus operations, standard keypad and display support, and extended math functionality.

4.1.5 Debugger

The PSoC Designer Debugger subsystem provides hardware in-circuit emulation, allowing you to test the program in a physical system while providing an internal view of the PSoC device. Debugger commands allow the designer to read and program and read and write data memory, read and write I/O registers, read and write CPU registers, set and clear breakpoints, and provide program run, halt, and step control. The debugger also allows the designer to create a trace buffer of registers and memory locations of interest.

4.1.6 Online Help System

The online help system displays online, context-sensitive help for the user. Designed for procedural and quick reference, each functional subsystem has its own context-sensitive help. This system also provides tutorials and links to FAQs and an Online Support Forum to aid the designer in getting started.

4.2 In-Circuit Emulator

A low cost, high functionality In-Circuit Emulator (ICE) is available for development support. This hardware has the capability to program single devices.

The emulator consists of a base unit that connects to the PC by way of a USB port. The base unit is universal and operates with all PSoC devices. Emulation pods for each device family are available separately. The emulation pod takes the place of the PSoC device in the target board and performs full speed (24 MHz) operation.

5. Designing with PSoC Designer

The development process for the PSoC device differs from that of a traditional fixed function microprocessor. The configurable analog and digital hardware blocks give the PSoC architecture a unique flexibility that pays dividends in managing specification change during development and by lowering inventory costs. These configurable resources, called PSoC Blocks, have the ability to implement a wide variety of user-selectable functions.

The PSoC development process can be summarized in the following four steps:

1. Select components
2. Configure components
3. Organize and Connect
4. Generate, Verify, and Debug

5.1 Select Components

Both the system-level and chip-level views provide a library of prebuilt, pretested hardware peripheral components. In the system-level view, these components are called “drivers” and correspond to inputs (a thermistor, for example), outputs (a brushless DC fan, for example), communication interfaces (I²C-bus, for example), and the logic to control how they interact with one another (called valuator).

In the chip-level view, the components are called “user modules”. User modules make selecting and implementing peripheral devices simple, and come in analog, digital, and mixed signal varieties.

5.2 Configure Components

Each of the components you select establishes the basic register settings that implement the selected function. They also provide parameters and properties that allow you to tailor their precise configuration to your particular application. For example, a Pulse Width Modulator (PWM) User Module configures one or more digital PSoC blocks, one for each 8 bits of resolution. The user module parameters permit you to establish the pulse width and duty cycle. Configure the parameters and properties to correspond to your chosen application. Enter values directly or by selecting values from drop-down menus.

Both the system-level drivers and chip-level user modules are documented in data sheets that are viewed directly in PSoC Designer. These data sheets explain the internal operation of the component and provide performance specifications. Each data sheet describes the use of each user module parameter or driver property, and other information you may need to successfully implement your design.

5.3 Organize and Connect

You can build signal chains at the chip level by interconnecting user modules to each other and the I/O pins, or connect system level inputs, outputs, and communication interfaces to each other with valuator functions.

In the system-level view, selecting a potentiometer driver to control a variable speed fan driver and setting up the valuator to control the fan speed based on input from the pot selects, places, routes, and configures a programmable gain amplifier (PGA) to buffer the input from the potentiometer, an analog to digital converter (ADC) to convert the potentiometer’s output to a digital signal, and a PWM to control the fan.

In the chip-level view, perform the selection, configuration, and routing so that you have complete control over the use of all on-chip resources.

5.4 Generate, Verify, and Debug

When you are ready to test the hardware configuration or move on to developing code for the project, perform the “Generate Application” step. This causes PSoC Designer to generate source code that automatically configures the device to your specification and provides the software for the system.

Both system-level and chip-level designs generate software based on your design. The chip-level design provides application programming interfaces (APIs) with high level functions to control and respond to hardware events at run-time and interrupt service routines that you can adapt as needed. The system-level design also generates a C main() program that completely controls the chosen application and contains placeholders for custom code at strategic positions allowing you to further refine the software without disrupting the generated code.

A complete code development environment allows you to develop and customize your applications in C, assembly language, or both.

The last step in the development process takes place inside the PSoC Designer’s Debugger subsystem. The Debugger downloads the HEX image to the ICE where it runs at full speed. Debugger capabilities rival those of systems costing many times more. In addition to traditional single-step, run-to-breakpoint and watch-variable features, the Debugger provides a large trace buffer and allows you define complex breakpoint events that include monitoring address and data bus values, memory locations and external signals.

6. Document Conventions

6.1 Acronyms Used

The following table lists the acronyms that are used in this document.

Acronym	Description
AC	alternating current
ADC	analog-to-digital converter
API	application programming interface
CPU	central processing unit
CT	continuous time
DAC	digital-to-analog converter
DC	direct current
ECO	external crystal oscillator
EEPROM	electrically erasable programmable read-only memory
FSR	full scale range
GPI/O	general purpose I/O
GUI	graphical user interface
HBM	human body model
ICE	in-circuit emulator
ILO	internal low speed oscillator
IMO	internal main oscillator
I/O	input/output
IPOR	imprecise power on reset
LSb	least-significant bit
LVD	low voltage detect
MSb	most-significant bit
PC	program counter
PLL	phase-locked loop
POR	power on reset
PPOR	precision power on reset
PSoC®	Programmable System-on-Chip™
PWM	pulse width modulator
SC	switched capacitor
SRAM	static random access memory

6.2 Units of Measure

A units of measure table is located in the Electrical Specifications section. [Table 9-1](#) on page 20 lists all the abbreviations used to measure the PSoC devices.

6.3 Numeric Naming

Hexadecimal numbers are represented with all letters in uppercase with an appended lowercase 'h' (for example, '14h' or '3Ah'). Hexadecimal numbers may also be represented by a '0x' prefix, the C coding convention. Binary numbers have an appended lowercase 'b' (e.g., '01010100b' or '01000011b'). Numbers not indicated by an 'h' or 'b' are decimal.

7. Pin Information

This section describes, lists, and illustrates the CY8C24x94 PSoC device family pins and pinout configuration.

The CY8C24x94 PSoC devices are available in the following packages, all of which are shown on the following pages. Every port pin (labeled with a “P”) is capable of Digital I/O. However, Vss, Vdd, and XRES are not capable of Digital I/O.

Note CY8C24794 must use Power Cycle programming when using the MiniProg.

7.1 56-Pin Part Pinout

Table 7-1. 56-Pin Part Pinout (QFN^[2]) See LEGEND details and footnotes in [Table 7-2 on page 9](#).

Pin No.	Type		Name	Description
	Digital	Analog		
1	I/O	I, M	P2[3]	Direct switched capacitor block input.
2	I/O	I, M	P2[1]	Direct switched capacitor block input.
3	I/O	M	P4[7]	
4	I/O	M	P4[5]	
5	I/O	M	P4[3]	
6	I/O	M	P4[1]	
7	I/O	M	P3[7]	
8	I/O	M	P3[5]	
9	I/O	M	P3[3]	
10	I/O	M	P3[1]	
11	I/O	M	P5[7]	
12	I/O	M	P5[5]	
13	I/O	M	P5[3]	
14	I/O	M	P5[1]	
15	I/O	M	P1[7]	I2C Serial Clock (SCL).
16	I/O	M	P1[5]	I2C Serial Data (SDA).
17	I/O	M	P1[3]	
18	I/O	M	P1[1]	I2C Serial Clock (SCL), ISSP SCLK ^[1] .
19	Power		Vss	Ground connection.
20	USB		D+	
21	USB		D-	
22	Power		Vdd	Supply voltage.
23	I/O		P7[7]	
24	I/O		P7[0]	
25	I/O	M	P1[0]	I2C Serial Data (SDA), ISSP SDA ^[1] .
26	I/O	M	P1[2]	
27	I/O	M	P1[4]	Optional External Clock Input (EXTCLK).
28	I/O	M	P1[6]	
29	I/O	M	P5[0]	
30	I/O	M	P5[2]	
31	I/O	M	P5[4]	
32	I/O	M	P5[6]	
33	I/O	M	P3[0]	
34	I/O	M	P3[2]	
35	I/O	M	P3[4]	
36	I/O	M	P3[6]	
37	I/O	M	P4[0]	
38	I/O	M	P4[2]	
39	I/O	M	P4[4]	
40	I/O	M	P4[6]	
41	I/O	I, M	P2[0]	Direct switched capacitor block input.
42	I/O	I, M	P2[2]	Direct switched capacitor block input.
43	I/O	M	P2[4]	External Analog Ground (AGND) input.
44	I/O	M	P2[6]	External Voltage Reference (VREF) input.
45	I/O	I, M	P0[0]	Analog column mux input.
46	I/O	I, M	P0[2]	Analog column mux input.
47	I/O	I, M	P0[4]	Analog column mux input VREF.
48	I/O	I, M	P0[6]	Analog column mux input.
49	Power		Vdd	Supply voltage.
50	Power		Vss	Ground connect/On.
51	I/O	I, M	P0[7]	Analog column mux input..
52	I/O	I/O, M	P0[5]	Analog column mux input and column output.
53	I/O	I/O, M	P0[3]	Analog column mux input and column output.
54	I/O	I, M	P0[1]	Analog column mux input.
55	I/O	M	P2[7]	
56	I/O	M	P2[5]	

Figure 7-1. CY8C24794 56-Pin PSoC Device

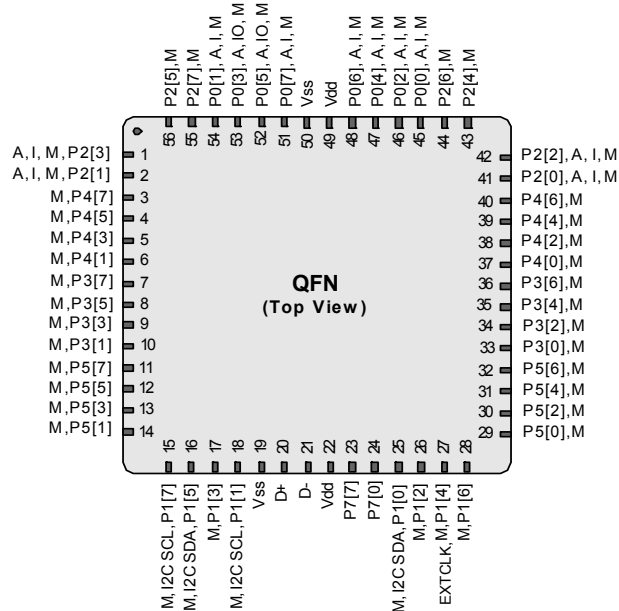

Pin No.	Type		Name	Description
	Digital	Analog		
44	I/O	M	P2[6]	External Voltage Reference (VREF) input.
45	I/O	I, M	P0[0]	Analog column mux input.
46	I/O	I, M	P0[2]	Analog column mux input.
47	I/O	I, M	P0[4]	Analog column mux input VREF.
48	I/O	I, M	P0[6]	Analog column mux input.
49	Power		Vdd	Supply voltage.
50	Power		Vss	Ground connect/On.
51	I/O	I, M	P0[7]	Analog column mux input..
52	I/O	I/O, M	P0[5]	Analog column mux input and column output.
53	I/O	I/O, M	P0[3]	Analog column mux input and column output.
54	I/O	I, M	P0[1]	Analog column mux input.
55	I/O	M	P2[7]	
56	I/O	M	P2[5]	

7.2 56-Pin Part Pinout (with XRES)

Table 7-2. 56-Pin Part Pinout (QFN^[2])

Pin No.	Type		Name	Description
	Digital	Analog		
1	I/O	I, M	P2[3]	Direct switched capacitor block input.
2	I/O	I, M	P2[1]	Direct switched capacitor block input.
3	I/O	M	P4[7]	
4	I/O	M	P4[5]	
5	I/O	M	P4[3]	
6	I/O	M	P4[1]	
7	I/O	M	P3[7]	
8	I/O	M	P3[5]	
9	I/O	M	P3[3]	
10	I/O	M	P3[1]	
11	I/O	M	P5[7]	
12	I/O	M	P5[5]	
13	I/O	M	P5[3]	
14	I/O	M	P5[1]	
15	I/O	M	P1[7]	I2C Serial Clock (SCL).
16	I/O	M	P1[5]	I2C Serial Data (SDA).
17	I/O	M	P1[3]	
18	I/O	M	P1[1]	I2C Serial Clock (SCL), ISSP SCLK ^[1] .
19	Power		Vss	Ground connection.
20	USB		D+	
21	USB		D-	
22	Power		Vdd	Supply voltage.
23	I/O		P7[7]	
24	I/O		P7[0]	
25	I/O	M	P1[0]	I2C Serial Data (SDA), ISSP SDATA ^[1] .
26	I/O	M	P1[2]	
27	I/O	M	P1[4]	Optional External Clock Input (EXTCLK).
28	I/O	M	P1[6]	
29	I/O	M	P5[0]	
30	I/O	M	P5[2]	
31	I/O	M	P5[4]	
32	I/O	M	P5[6]	
33	I/O	M	P3[0]	
34	I/O	M	P3[2]	
35	I/O	M	P3[4]	
36	Input		XRES	Active high external reset with internal pull down.
37	I/O	M	P4[0]	
38	I/O	M	P4[2]	
39	I/O	M	P4[4]	
40	I/O	M	P4[6]	
41	I/O	I, M	P2[0]	Direct switched capacitor block input.
42	I/O	I, M	P2[2]	Direct switched capacitor block input.
43	I/O	M	P2[4]	External Analog Ground (AGND) input.
44	I/O	M	P2[6]	External Voltage Reference (VREF) input.
45	I/O	I, M	P0[0]	Analog column mux input.
46	I/O	I, M	P0[2]	Analog column mux input.
47	I/O	I, M	P0[4]	Analog column mux input VREF.
48	I/O	I, M	P0[6]	Analog column mux input.
49	Power		Vdd	Supply voltage.
50	Power		Vss	Ground connection.
51	I/O	I, M	P0[7]	Analog column mux input.
52	I/O	I/O, M	P0[5]	Analog column mux input and column output.
53	I/O	I/O, M	P0[3]	Analog column mux input and column output.
54	I/O	I, M	P0[1]	Analog column mux input.
55	I/O	M	P2[7]	
56	I/O	M	P2[5]	

Figure 7-2. CY8C24894 56-Pin PSoC Device

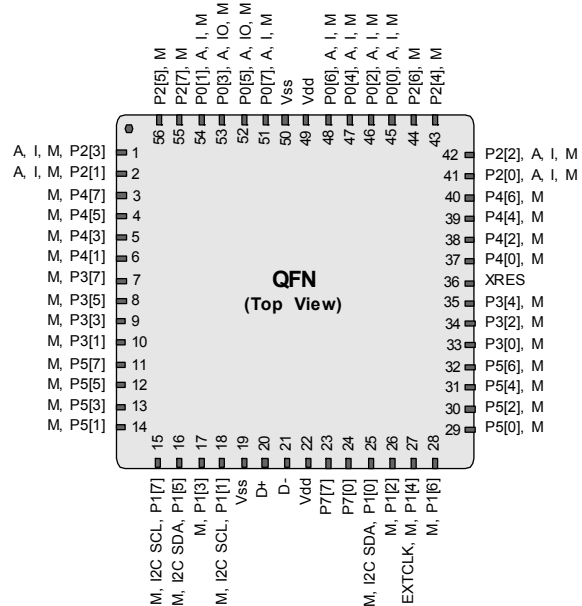

Pin No.	Type		Name	Description
	Digital	Analog		
44	I/O	M	P2[6]	External Voltage Reference (VREF) input.
45	I/O	I, M	P0[0]	Analog column mux input.
46	I/O	I, M	P0[2]	Analog column mux input.
47	I/O	I, M	P0[4]	Analog column mux input VREF.
48	I/O	I, M	P0[6]	Analog column mux input.
49	Power		Vdd	Supply voltage.
50	Power		Vss	Ground connection.
51	I/O	I, M	P0[7]	Analog column mux input.
52	I/O	I/O, M	P0[5]	Analog column mux input and column output.
53	I/O	I/O, M	P0[3]	Analog column mux input and column output.
54	I/O	I, M	P0[1]	Analog column mux input.
55	I/O	M	P2[7]	
56	I/O	M	P2[5]	

LEGEND A = Analog, I = Input, O = Output, and M = Analog Mux Input.

Notes

- These are the ISSP pins, which are not High Z at POR. See the PSoC Programmable System-on-Chip Technical Reference Manual for details.
- The center pad on the QFN package should be connected to ground (Vss) for best mechanical, thermal, and electrical performance. If not connected to ground, it should be electrically floated and not connected to any other signal.

7.3 68-Pin Part Pinout

The following 68-pin QFN part table and drawing is for the CY8C24994 PSoC device.

Table 7-3. 68-Pin Part Pinout (QFN^[2])

Pin No.	Type		Name	Description
	Digital	Analog		
1	I/O	M	P4[7]	
2	I/O	M	P4[5]	
3	I/O	M	P4[3]	
4	I/O	M	P4[1]	
5			NC	No connection.
6			NC	No connection.
7	Power		Vss	Ground connection.
8	I/O	M	P3[7]	
9	I/O	M	P3[5]	
10	I/O	M	P3[3]	
11	I/O	M	P3[1]	
12	I/O	M	P5[7]	
13	I/O	M	P5[5]	
14	I/O	M	P5[3]	
15	I/O	M	P5[1]	
16	I/O	M	P1[7]	I2C Serial Clock (SCL).
17	I/O	M	P1[5]	I2C Serial Data (SDA).
18	I/O	M	P1[3]	
19	I/O	M	P1[1]	I2C Serial Clock (SCL) ISSP SCLK ^[1] .
20	Power		Vss	Ground connection.
21	USB		D+	
22	USB		D-	
23	Power		Vdd	Supply voltage.
24	I/O		P7[7]	
25	I/O		P7[6]	
26	I/O		P7[5]	
27	I/O		P7[4]	
28	I/O		P7[3]	
29	I/O		P7[2]	
30	I/O		P7[1]	
31	I/O		P7[0]	
32	I/O	M	P1[0]	I2C Serial Data (SDA), ISSP SDATA ^[1] .
33	I/O	M	P1[2]	
34	I/O	M	P1[4]	Optional External Clock Input (EXTCLK).
35	I/O	M	P1[6]	
36	I/O	M	P5[0]	
37	I/O	M	P5[2]	
38	I/O	M	P5[4]	
39	I/O	M	P5[6]	
40	I/O	M	P3[0]	
41	I/O	M	P3[2]	
42	I/O	M	P3[4]	
43	I/O	M	P3[6]	
44			NC	No connection.
45			NC	No connection.
46	Input		XRES	Active high pin reset with internal pull down.
47	I/O	M	P4[0]	
48	I/O	M	P4[2]	
49	I/O	M	P4[4]	

Figure 7-3. CY8C24994 68-Pin PSoC Device

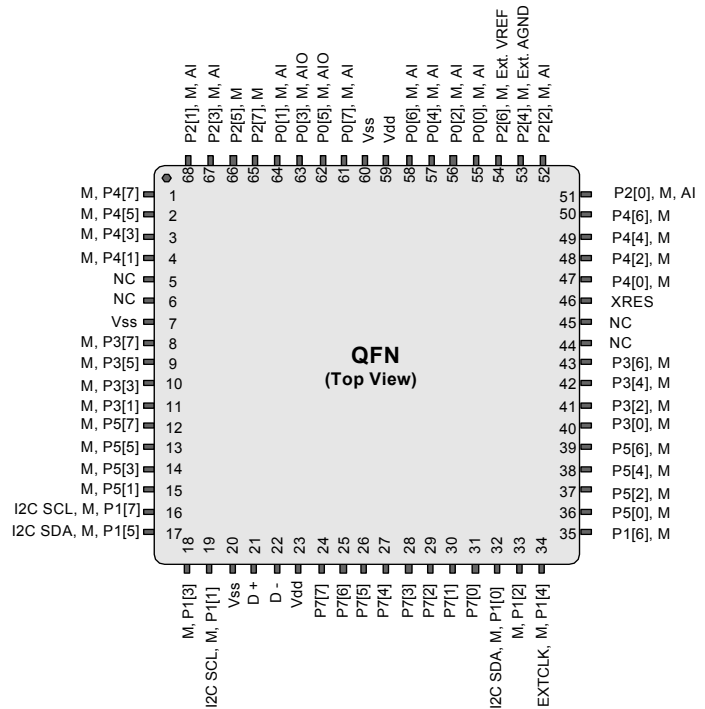

Pin No.	Type		Name	Description
	Digital	Analog		
50	I/O	M	P4[6]	
51	I/O	I,M	P2[0]	Direct switched capacitor block input.
52	I/O	I,M	P2[2]	Direct switched capacitor block input.
53	I/O	M	P2[4]	External Analog Ground (AGND) input.
54	I/O	M	P2[6]	External Voltage Reference (VREF) input.
55	I/O	I,M	P0[0]	Analog column mux input.
56	I/O	I,M	P0[2]	Analog column mux input and column output.
57	I/O	I,M	P0[4]	Analog column mux input and column output.
58	I/O	I,M	P0[6]	Analog column mux input.
59	Power		Vdd	Supply voltage.
60	Power		Vss	Ground connection.
61	I/O	I,M	P0[7]	Analog column mux input, integration input #1
62	I/O	I/O,M	P0[5]	Analog column mux input and column output, integration input #2.
63	I/O	I/O,M	P0[3]	Analog column mux input and column output.
64	I/O	I,M	P0[1]	Analog column mux input.
65	I/O	M	P2[7]	
66	I/O	M	P2[5]	
67	I/O	I,M	P2[3]	Direct switched capacitor block input.
68	I/O	I,M	P2[1]	Direct switched capacitor block input.

LEGENDA = Analog, I = Input, O = Output, NC = No Connection, M = Analog Mux Input.

7.5 100-Ball VFBGA Part Pinout

The 100-ball VFBGA part is for the CY8C24994 PSoC device.

Table 7-5. 100-Ball Part Pinout (VFBGA)

Pin No.	Digital	Analog	Name	Description	Pin No.	Digital	Analog	Name	Description
A1	Power		Vss	Ground connection.	F1			NC	No connection.
A2	Power		Vss	Ground connection.	F2	I/O	M	P5[7]	
A3			NC	No connection.	F3	I/O	M	P3[5]	
A4			NC	No connection.	F4	I/O	M	P5[1]	
A5			NC	No connection.	F5	Power		Vss	Ground connection.
A6	Power		Vdd	Supply voltage.	F6	Power		Vss	Ground connection.
A7			NC	No connection.	F7	I/O	M	P5[0]	
A8			NC	No connection.	F8	I/O	M	P3[0]	
A9	Power		Vss	Ground connection.	F9			XRES	Active high pin reset with internal pull down.
A10	Power		Vss	Ground connection.	F10	I/O		P7[1]	
B1	Power		Vss	Ground connection.	G1			NC	No connection.
B2	Power		Vss	Ground connection.	G2	I/O	M	P5[5]	
B3	I/O	I,M	P2[1]	Direct switched capacitor block input.	G3	I/O	M	P3[3]	
B4	I/O	I,M	P0[1]	Analog column mux input.	G4	I/O	M	P1[7]	I2C Serial Clock (SCL).
B5	I/O	I,M	P0[7]	Analog column mux input.	G5	I/O	M	P1[1]	I2C Serial Clock (SCL), ISSP SCLK ^{†1} .
B6	Power		Vdd	Supply voltage.	G6	I/O	M	P1[0]	I2C Serial Data (SDA), ISSP SDATA ^{†1} .
B7	I/O	I,M	P0[2]	Analog column mux input.	G7	I/O	M	P1[6]	
B8	I/O	I,M	P2[2]	Direct switched capacitor block input.	G8	I/O	M	P3[4]	
B9	Power		Vss	Ground connection.	G9	I/O	M	P5[6]	
B10	Power		Vss	Ground connection.	G10	I/O		P7[2]	
C1			NC	No connection.	H1			NC	No connection.
C2	I/O	M	P4[1]		H2	I/O	M	P5[3]	
C3	I/O	M	P4[7]		H3	I/O	M	P3[1]	
C4	I/O	M	P2[7]		H4	I/O	M	P1[5]	I2C Serial Data (SDA).
C5	I/O	I/O,M	P0[5]	Analog column mux input and column output.	H5	I/O	M	P1[3]	
C6	I/O	I,M	P0[6]	Analog column mux input.	H6	I/O	M	P1[2]	
C7	I/O	I,M	P0[0]	Analog column mux input.	H7	I/O	M	P1[4]	Optional External Clock Input (EXTCLK).
C8	I/O	I,M	P2[0]	Direct switched capacitor block input.	H8	I/O	M	P3[2]	
C9	I/O	M	P4[2]		H9	I/O	M	P5[4]	
C10			NC	No connection.	H10	I/O		P7[3]	
D1			NC	No connection.	J1	Power		Vss	Ground connection.
D2	I/O	M	P3[7]		J2	Power		Vss	Ground connection.
D3	I/O	M	P4[5]		J3	USB		D+	
D4	I/O	M	P2[5]		J4	USB		D-	
D5	I/O	I/O,M	P0[3]	Analog column mux input and column output.	J5	Power		Vdd	Supply voltage.
D6	I/O	I,M	P0[4]	Analog column mux input.	J6	I/O		P7[7]	
D7	I/O	M	P2[6]	External Voltage Reference (VREF) input.	J7	I/O		P7[0]	
D8	I/O	M	P4[6]		J8	I/O	M	P5[2]	
D9	I/O	M	P4[0]		J9	Power		Vss	Ground connection.
D10			NC	No connection.	J10	Power		Vss	Ground connection.
E1			NC	No connection.	K1	Power		Vss	Ground connection.
E2			NC	No connection.	K2	Power		Vss	Ground connection.
E3	I/O	M	P4[3]		K3			NC	No connection.
E4	I/O	I,M	P2[3]	Direct switched capacitor block input.	K4			NC	No connection.
E5	Power		Vss	Ground connection.	K5	Power		Vdd	Supply voltage.
E6	Power		Vss	Ground connection.	K6	I/O		P7[6]	
E7	I/O	M	P2[4]	External Analog Ground (AGND) input.	K7	I/O		P7[5]	
E8	I/O	M	P4[4]		K8	I/O		P7[4]	
E9	I/O	M	P3[6]		K9	Power		Vss	Ground connection.
E10			NC	No connection.	K10	Power		Vss	Ground connection.

LEGENDA = Analog, I = Input, O = Output, M = Analog Mux Input, NC = No Connection.

Figure 7-5. CY8C24094 OCD (Not for Production)

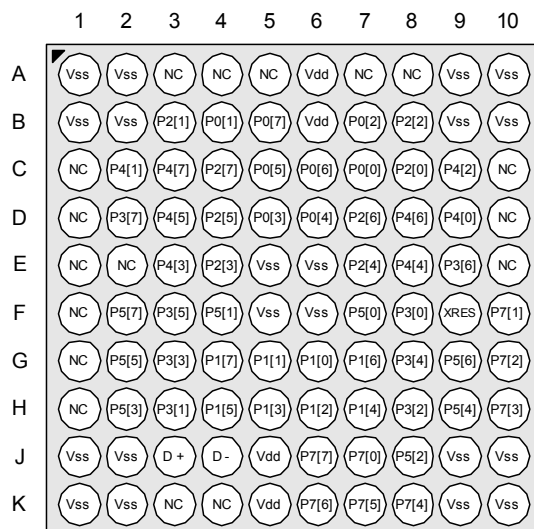

BGA (Top View)

7.6 100-Ball VFBGA Part Pinout (On-Chip Debug)

The following 100-pin VFBGA part table and drawing is for the CY8C24094 On-Chip Debug (OCD) PSoC device.

Note This part is only used for in-circuit debugging. It is NOT available for production.

Table 7-6. 100-Ball Part Pinout (VFBGA)

Pin No.	Digital	Analog	Name	Description	Pin No.	Digital	Analog	Name	Description
A1	Power		Vss	Ground connection.	F1			OCDE	OCD even data I/O.
A2	Power		Vss	Ground connection.	F2	I/O	M	P5[7]	
A3			NC	No connection.	F3	I/O	M	P3[5]	
A4			NC	No connection.	F4	I/O	M	P5[1]	
A5			NC	No connection.	F5	Power		Vss	Ground connection.
A6	Power		Vdd	Supply voltage.	F6	Power		Vss	Ground connection.
A7			NC	No connection.	F7	I/O	M	P5[0]	
A8			NC	No connection.	F8	I/O	M	P3[0]	
A9	Power		Vss	Ground connection.	F9			XRES	Active high pin reset with internal pull down.
A10	Power		Vss	Ground connection.	F10	I/O		P7[1]	
B1	Power		Vss	Ground connection.	G1			OCDO	OCD odd data output.
B2	Power		Vss	Ground connection.	G2	I/O	M	P5[5]	
B3	I/O	I,M	P2[1]	Direct switched capacitor block input.	G3	I/O	M	P3[3]	
B4	I/O	I,M	P0[1]	Analog column mux input.	G4	I/O	M	P1[7]	I2C Serial Clock (SCL).
B5	I/O	I,M	P0[7]	Analog column mux input.	G5	I/O	M	P1[1]	I2C Serial Clock (SCL), ISSP SCLK ¹ .
B6	Power		Vdd	Supply voltage.	G6	I/O	M	P1[0]	I2C Serial Data (SDA), ISSP SDA ¹ .
B7	I/O	I,M	P0[2]	Analog column mux input.	G7	I/O	M	P1[6]	
B8	I/O	I,M	P2[2]	Direct switched capacitor block input.	G8	I/O	M	P3[4]	
B9	Power		Vss	Ground connection.	G9	I/O	M	P5[6]	
B10	Power		Vss	Ground connection.	G10	I/O		P7[2]	
C1			NC	No connection.	H1			NC	No connection.
C2	I/O	M	P4[1]		H2	I/O	M	P5[3]	
C3	I/O	M	P4[7]		H3	I/O	M	P3[1]	
C4	I/O	M	P2[7]		H4	I/O	M	P1[5]	I2C Serial Data (SDA).
C5	I/O	I/O, M	P0[5]	Analog column mux input and column output.	H5	I/O	M	P1[3]	
C6	I/O	I,M	P0[6]	Analog column mux input.	H6	I/O	M	P1[2]	
C7	I/O	I,M	P0[0]	Analog column mux input.	H7	I/O	M	P1[4]	Optional External Clock Input (EXTCLK).

Table 7-6. 100-Ball Part Pinout (VFPGA) (continued)

C8	I/O	I,M	P2[0]	Direct switched capacitor block input.	H8	I/O	M	P3[2]	
C9	I/O	M	P4[2]		H9	I/O	M	P5[4]	
C10			NC	No connection.	H10	I/O		P7[3]	
D1			NC	No connection.	J1	Power		Vss	Ground connection.
D2	I/O	M	P3[7]		J2	Power		Vss	Ground connection.
D3	I/O	M	P4[5]		J3	USB		D+	
D4	I/O	M	P2[5]		J4	USB		D-	
D5	I/O	I/O, M	P0[3]	Analog column mux input and column output.	J5	Power		Vdd	Supply voltage.
D6	I/O	I,M	P0[4]	Analog column mux input.	J6	I/O		P7[7]	
D7	I/O	M	P2[6]	External Voltage Reference (VREF) input.	J7	I/O		P7[0]	
D8	I/O	M	P4[6]		J8	I/O	M	P5[2]	
D9	I/O	M	P4[0]		J9	Power		Vss	Ground connection.
D10			CCLK	OCD CPU clock output.	J10	Power		Vss	Ground connection.
E1			NC	No connection.	K1	Power		Vss	Ground connection.
E2			NC	No connection.	K2	Power		Vss	Ground connection.
E3	I/O	M	P4[3]		K3			NC	No connection.
E4	I/O	I,M	P2[3]	Direct switched capacitor block input.	K4			NC	No connection.
E5	Power		Vss	Ground connection.	K5	Power		Vdd	Supply voltage.
E6	Power		Vss	Ground connection.	K6	I/O		P7[6]	
E7	I/O	M	P2[4]	External Analog Ground (AGND) input.	K7	I/O		P7[5]	
E8	I/O	M	P4[4]		K8	I/O		P7[4]	
E9	I/O	M	P3[6]		K9	Power		Vss	Ground connection.
E10			HCLK	OCD high speed clock output.	K10	Power		Vss	Ground connection.

LEGENDA = Analog, I = Input, O = Output, M = Analog Mux Input, NC = No Connection, OCD = On-Chip Debugger.

Figure 7-6. CY8C24094 OCD (Not for Production)

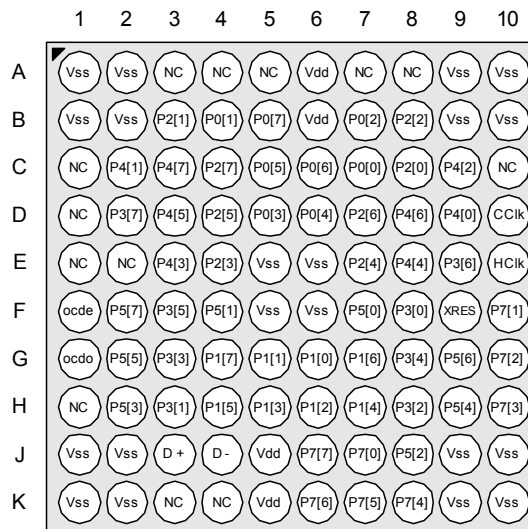

BGA (Top View)

7.7 100-Pin Part Pinout (On-Chip Debug)

The 100-pin TQFP part is for the CY8C24094 On-Chip Debug (OCD) PSoC device.

Note This part is only used for in-circuit debugging. It is NOT available for production.

Table 7-7. 100-Pin Part Pinout (TQFP)

Pin No.	Digital	Analog	Name	Description	Pin No.	Digital	Analog	Name	Description
1			NC	No connection.	51	I/O	M	P1[6]	
2			NC	No connection.	52	I/O	M	P5[0]	
3	I/O	I, M	P0[1]	Analog column mux input.	53	I/O	M	P5[2]	
4	I/O	M	P2[7]		54	I/O	M	P5[4]	
5	I/O	M	P2[5]		55	I/O	M	P5[6]	
6	I/O	I, M	P2[3]	Direct switched capacitor block input.	56	I/O	M	P3[0]	
7	I/O	I, M	P2[1]	Direct switched capacitor block input.	57	I/O	M	P3[2]	
8	I/O	M	P4[7]		58	I/O	M	P3[4]	
9	I/O	M	P4[5]		59	I/O	M	P3[6]	
10	I/O	M	P4[3]		60			HCLK	OCD high speed clock output.
11	I/O	M	P4[1]		61			CCLK	OCD CPU clock output.
12			OCDE	OCD even data I/O.	62	Input		XRES	Active high pin reset with internal pull down.
13			OCDO	OCD odd data output.	63	I/O	M	P4[0]	
14			NC	No connection.	64	I/O	M	P4[2]	
15	Power		Vss	Ground connection.	65	Power		Vss	Ground connection.
16	I/O	M	P3[7]		66	I/O	M	P4[4]	
17	I/O	M	P3[5]		67	I/O	M	P4[6]	
18	I/O	M	P3[3]		68	I/O	I, M	P2[0]	Direct switched capacitor block input.
19	I/O	M	P3[1]		69	I/O	I, M	P2[2]	Direct switched capacitor block input.
20	I/O	M	P5[7]		70	I/O		P2[4]	External Analog Ground (AGND) input.
21	I/O	M	P5[5]		71			NC	No connection.
22	I/O	M	P5[3]		72	I/O		P2[6]	External Voltage Reference (VREF) input.
23	I/O	M	P5[1]		73			NC	No connection.
24	I/O	M	P1[7]	I2C Serial Clock (SCL).	74	I/O	I	P0[0]	Analog column mux input.
25			NC	No connection.	75			NC	No connection.
26			NC	No connection.	76			NC	No connection.
27			NC	No connection.	77	I/O	I, M	P0[2]	Analog column mux input and column output.
28	I/O		P1[5]	I2C Serial Data (SDA)	78			NC	No connection.
29	I/O		P1[3]		79	I/O	I, M	P0[4]	Analog column mux input and column output.
30	I/O		P1[1]	Crystal (XTAL _{in}), I2C Serial Clock (SCL), ISSP SCLK ^[1] .	80			NC	No connection.
31			NC	No connection.	81	I/O	I, M	P0[6]	Analog column mux input.
32	Power		Vss	Ground connection.	82	Power		Vdd	Supply voltage.
33	USB		D+		83			NC	No connection.
34	USB		D-		84	Power		Vss	Ground connection.
35	Power		Vdd	Supply voltage.	85			NC	No connection.
36	I/O		P7[7]		86			NC	No connection.
37	I/O		P7[6]		87			NC	No connection.
38	I/O		P7[5]		88			NC	No connection.
39	I/O		P7[4]		89			NC	No connection.
40	I/O		P7[3]		90			NC	No connection.
41	I/O		P7[2]		91			NC	No connection.
42	I/O		P7[1]		92			NC	No connection.
43	I/O		P7[0]		93			NC	No connection.
44			NC	No connection.	94			NC	No connection.
45			NC	No connection.	95	I/O	I, M	P0[7]	Analog column mux input.
46			NC	No connection.	96			NC	No connection.
47			NC	No connection.	97	I/O	I/O, M	P0[5]	Analog column mux input and column output.
48	I/O		P1[0]	Crystal (XTAL _{out}), I2C Serial Data (SDA), ISSP SDA _{TA} ^[1] .	98			NC	No connection.
49	I/O		P1[2]		99	I/O	I/O, M	P0[3]	Analog column mux input and column output.
50	I/O		P1[4]	Optional External Clock Input (EXTCLK).	100			NC	No connection.

Table 7-7. 100-Pin Part Pinout (TQFP) (continued)

LEGENDA = Analog, I = Input, O = Output, NC = No Connection, M = Analog Mux Input, OCD = On-Chip Debugger.

Figure 7-7. CY8C24094 OCD (Not for Production)

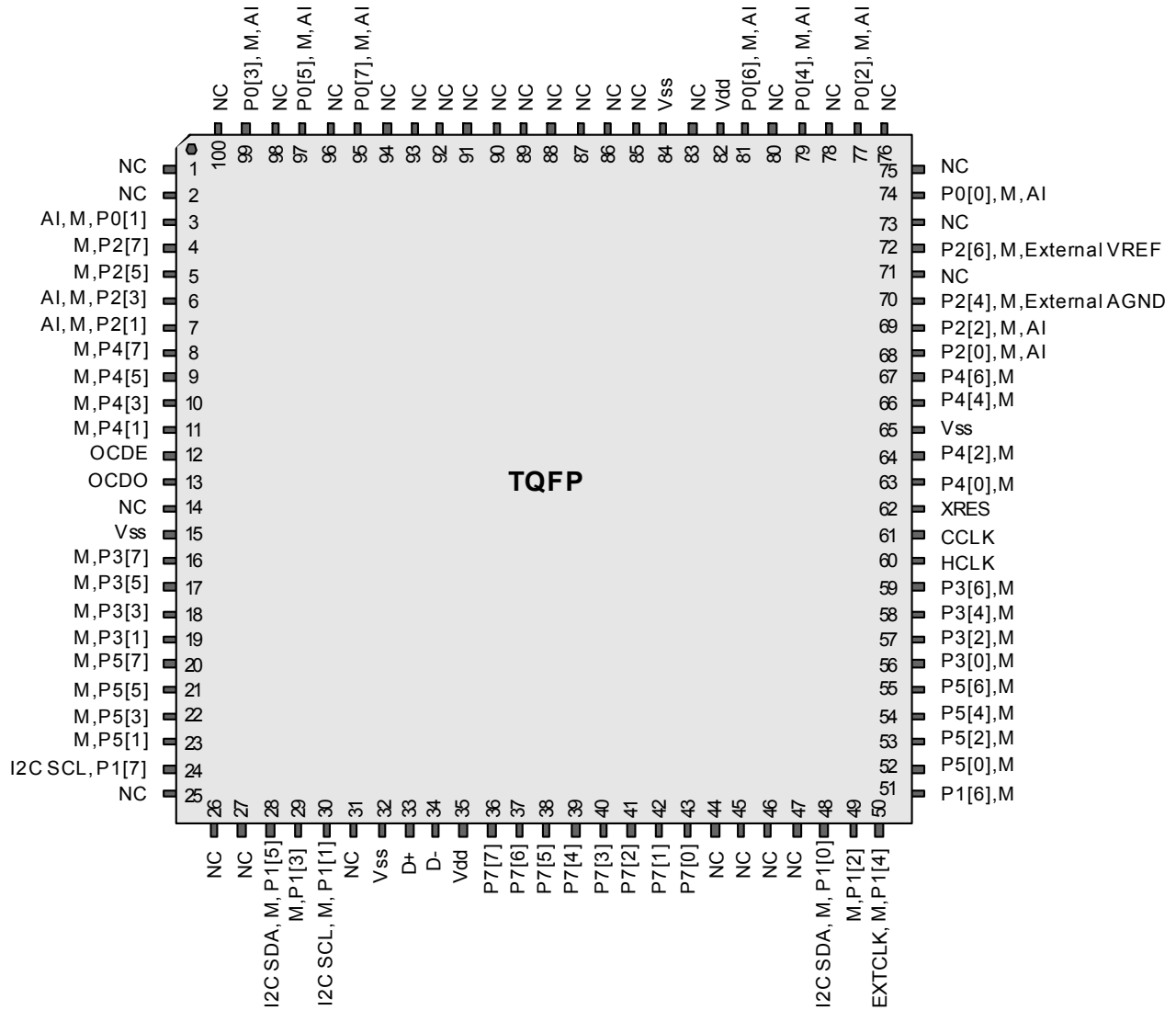

8. Register Reference

This section lists the registers of the CY8C24x94 PSoC device family. For detailed register information, reference the *PSoC Programmable System-on-Chip Technical Reference Manual*.

8.1 Register Conventions

The register conventions specific to this section are listed in the following table.

Convention	Description
R	Read register or bit(s)
W	Write register or bit(s)
L	Logical register or bit(s)
C	Clearable register or bit(s)
#	Access is bit specific

8.2 Register Mapping Tables

The PSoC device has a total register address space of 512 bytes. The register space is referred to as I/O space and is divided into two banks. The XO1 bit in the Flag register (CPU_F) determines which bank the user is currently in. When the XO1 bit is set the user is in Bank 1.

Note In the following register mapping tables, blank fields are Reserved and should not be accessed.



8.3 Register Map Bank 0 Table: User Space

Name	Addr (0,Hex)	Access	Name	Addr (0,Hex)	Access	Name	Addr (0,Hex)	Access	Name	Addr (0,Hex)	Access
PRT0DR	00	RW	PMA0_DR	40	RW	ASC10CR0	80	RW		C0	
PRT0IE	01	RW	PMA1_DR	41	RW	ASC10CR1	81	RW		C1	
PRT0GS	02	RW	PMA2_DR	42	RW	ASC10CR2	82	RW		C2	
PRT0DM2	03	RW	PMA3_DR	43	RW	ASC10CR3	83	RW		C3	
PRT1DR	04	RW	PMA4_DR	44	RW	ASD11CR0	84	RW		C4	
PRT1IE	05	RW	PMA5_DR	45	RW	ASD11CR1	85	RW		C5	
PRT1GS	06	RW	PMA6_DR	46	RW	ASD11CR2	86	RW		C6	
PRT1DM2	07	RW	PMA7_DR	47	RW	ASD11CR3	87	RW		C7	
PRT2DR	08	RW	USB_SOF0	48	R		88			C8	
PRT2IE	09	RW	USB_SOF1	49	R		89			C9	
PRT2GS	0A	RW	USB_CR0	4A	RW		8A			CA	
PRT2DM2	0B	RW	USB/O_CR0	4B	#		8B			CB	
PRT3DR	0C	RW	USB/O_CR1	4C	RW		8C			CC	
PRT3IE	0D	RW		4D			8D			CD	
PRT3GS	0E	RW	EP1_CNT1	4E	#		8E			CE	
PRT3DM2	0F	RW	EP1_CNT	4F	RW		8F			CF	
PRT4DR	10	RW	EP2_CNT1	50	#	ASD20CR0	90	RW	CUR_PP	D0	RW
PRT4IE	11	RW	EP2_CNT	51	RW	ASD20CR1	91	RW	STK_PP	D1	RW
PRT4GS	12	RW	EP3_CNT1	52	#	ASD20CR2	92	RW		D2	
PRT4DM2	13	RW	EP3_CNT	53	RW	ASD20CR3	93	RW	IDX_PP	D3	RW
PRT5DR	14	RW	EP4_CNT1	54	#	ASC21CR0	94	RW	MVR_PP	D4	RW
PRT5IE	15	RW	EP4_CNT	55	RW	ASC21CR1	95	RW	MVW_PP	D5	RW
PRT5GS	16	RW	EP0_CR	56	#	ASC21CR2	96	RW	I2C_CFG	D6	RW
PRT5DM2	17	RW	EP0_CNT	57	#	ASC21CR3	97	RW	I2C_SCR	D7	#
	18		EP0_DR0	58	RW		98		I2C_DR	D8	RW
	19		EP0_DR1	59	RW		99		I2C_MSCR	D9	#
	1A		EP0_DR2	5A	RW		9A		INT_CLR0	DA	RW
	1B		EP0_DR3	5B	RW		9B		INT_CLR1	DB	RW
PRT7DR	1C	RW	EP0_DR4	5C	RW		9C		INT_CLR2	DC	RW
PRT7IE	1D	RW	EP0_DR5	5D	RW		9D		INT_CLR3	DD	RW
PRT7GS	1E	RW	EP0_DR6	5E	RW		9E		INT_MSK3	DE	RW
PRT7DM2	1F	RW	EP0_DR7	5F	RW		9F		INT_MSK2	DF	RW
DBB00DR0	20	#	AMX_IN	60	RW		A0		INT_MSK0	E0	RW
DBB00DR1	21	W	AMUXCFG	61	RW		A1		INT_MSK1	E1	RW
DBB00DR2	22	RW		62			A2		INT_VC	E2	RC
DBB00CR0	23	#	ARF_CR	63	RW		A3		RES_WDT	E3	W
DBB01DR0	24	#	CMP_CR0	64	#		A4		DEC_DH	E4	RC
DBB01DR1	25	W	ASY_CR	65	#		A5		DEC_DL	E5	RC
DBB01DR2	26	RW	CMP_CR1	66	RW		A6		DEC_CR0	E6	RW
DBB01CR0	27	#		67			A7		DEC_CR1	E7	RW
DCB02DR0	28	#		68		MUL1_X	A8	W	MUL0_X	E8	W
DCB02DR1	29	W		69		MUL1_Y	A9	W	MUL0_Y	E9	W
DCB02DR2	2A	RW		6A		MUL1_DH	AA	R	MUL0_DH	EA	R
DCB02CR0	2B	#		6B		MUL1_DL	AB	R	MUL0_DL	EB	R
DCB03DR0	2C	#	TMP_DR0	6C	RW	ACC1_DR1	AC	RW	ACC0_DR1	EC	RW
DCB03DR1	2D	W	TMP_DR1	6D	RW	ACC1_DR0	AD	RW	ACC0_DR0	ED	RW
DCB03DR2	2E	RW	TMP_DR2	6E	RW	ACC1_DR3	AE	RW	ACC0_DR3	EE	RW
DCB03CR0	2F	#	TMP_DR3	6F	RW	ACC1_DR2	AF	RW	ACC0_DR2	EF	RW
	30		ACB00CR3	70	RW	RDI0RI	B0	RW		F0	
	31		ACB00CR0	71	RW	RDI0SYN	B1	RW		F1	
	32		ACB00CR1	72	RW	RDI0IS	B2	RW		F2	
	33		ACB00CR2	73	RW	RDI0LT0	B3	RW		F3	
	34		ACB01CR3	74	RW	RDI0LT1	B4	RW		F4	
	35		ACB01CR0	75	RW	RDI0RO0	B5	RW		F5	
	36		ACB01CR1	76	RW	RDI0RO1	B6	RW		F6	
	37		ACB01CR2	77	RW		B7		CPU_F	F7	RL
	38			78			B8			F8	
	39			79			B9			F9	
	3A			7A			BA			FA	
	3B			7B			BB			FB	
	3C			7C			BC			FC	
	3D			7D			BD		DAC_D	FD	RW
	3E			7E			BE		CPU_SCR1	FE	#
	3F			7F			BF		CPU_SCR0	FF	#

Blank fields are Reserved and should not be accessed.

Access is bit specific.



8.4 Register Map Bank 1 Table: Configuration Space

Name	Addr (1,Hex)	Access	Name	Addr (1,Hex)	Access	Name	Addr (1,Hex)	Access	Name	Addr (1,Hex)	Access
PRT0DM0	00	RW	PMA0_WA	40	RW	ASC10CR0	80	RW	USB/O_CR2	C0	RW
PRT0DM1	01	RW	PMA1_WA	41	RW	ASC10CR1	81	RW	USB_CR1	C1	#
PRT0IC0	02	RW	PMA2_WA	42	RW	ASC10CR2	82	RW			
PRT0IC1	03	RW	PMA3_WA	43	RW	ASC10CR3	83	RW			
PRT1DM0	04	RW	PMA4_WA	44	RW	ASD11CR0	84	RW	EP1_CR0	C4	#
PRT1DM1	05	RW	PMA5_WA	45	RW	ASD11CR1	85	RW	EP2_CR0	C5	#
PRT1IC0	06	RW	PMA6_WA	46	RW	ASD11CR2	86	RW	EP3_CR0	C6	#
PRT1IC1	07	RW	PMA7_WA	47	RW	ASD11CR3	87	RW	EP4_CR0	C7	#
PRT2DM0	08	RW		48			88			C8	
PRT2DM1	09	RW		49			89			C9	
PRT2IC0	0A	RW		4A			8A			CA	
PRT2IC1	0B	RW		4B			8B			CB	
PRT3DM0	0C	RW		4C			8C			CC	
PRT3DM1	0D	RW		4D			8D			CD	
PRT3IC0	0E	RW		4E			8E			CE	
PRT3IC1	0F	RW		4F			8F			CF	
PRT4DM0	10	RW	PMA0_RA	50	RW		90		GDI_O_IN	D0	RW
PRT4DM1	11	RW	PMA1_RA	51	RW	ASD20CR1	91	RW	GDI_E_IN	D1	RW
PRT4IC0	12	RW	PMA2_RA	52	RW	ASD20CR2	92	RW	GDI_O_OU	D2	RW
PRT4IC1	13	RW	PMA3_RA	53	RW	ASD20CR3	93	RW	GDI_E_OU	D3	RW
PRT5DM0	14	RW	PMA4_RA	54	RW	ASC21CR0	94	RW		D4	
PRT5DM1	15	RW	PMA5_RA	55	RW	ASC21CR1	95	RW		D5	
PRT5IC0	16	RW	PMA6_RA	56	RW	ASC21CR2	96	RW		D6	
PRT5IC1	17	RW	PMA7_RA	57	RW	ASC21CR3	97	RW		D7	
	18			58			98		MUX_CR0	D8	RW
	19			59			99		MUX_CR1	D9	RW
	1A			5A			9A		MUX_CR2	DA	RW
	1B			5B			9B		MUX_CR3	DB	RW
PRT7DM0	1C	RW		5C			9C			DC	
PRT7DM1	1D	RW		5D			9D		OSC_GO_EN	DD	RW
PRT7IC0	1E	RW		5E			9E		OSC_CR4	DE	RW
PRT7IC1	1F	RW		5F			9F		OSC_CR3	DF	RW
DBB00FN	20	RW	CLK_CR0	60	RW		A0		OSC_CR0	E0	RW
DBB00IN	21	RW	CLK_CR1	61	RW		A1		OSC_CR1	E1	RW
DBB00OU	22	RW	ABF_CR0	62	RW		A2		OSC_CR2	E2	RW
	23		AMD_CR0	63	RW		A3		VLT_CR	E3	RW
DBB01FN	24	RW	CMP_GO_EN	64	RW		A4		VLT_CMP	E4	R
DBB01IN	25	RW		65			A5			E5	
DBB01OU	26	RW	AMD_CR1	66	RW		A6			E6	
	27		ALT_CR0	67	RW		A7			E7	
DCB02FN	28	RW		68			A8		IMO_TR	E8	W
DCB02IN	29	RW		69			A9		ILO_TR	E9	W
DCB02OU	2A	RW		6A			AA		BDG_TR	EA	RW
	2B			6B			AB		ECO_TR	EB	W
DCB03FN	2C	RW	TMP_DR0	6C	RW		AC		MUX_CR4	EC	RW
DCB03IN	2D	RW	TMP_DR1	6D	RW		AD		MUX_CR5	ED	RW
DCB03OU	2E	RW	TMP_DR2	6E	RW		AE			EE	
	2F		TMP_DR3	6F	RW		AF			EF	
	30		ACB00CR3	70	RW	RDIO0RI	B0	RW		F0	
	31		ACB00CR0	71	RW	RDIO0SYN	B1	RW		F1	
	32		ACB00CR1	72	RW	RDIO0IS	B2	RW		F2	
	33		ACB00CR2	73	RW	RDIO0LT0	B3	RW		F3	
	34		ACB01CR3	74	RW	RDIO0LT1	B4	RW		F4	
	35		ACB01CR0	75	RW	RDIO0RO0	B5	RW		F5	
	36		ACB01CR1	76	RW	RDIO0RO1	B6	RW		F6	
	37		ACB01CR2	77	RW		B7		CPU_F	F7	RL
	38			78			B8			F8	
	39			79			B9			F9	
	3A			7A			BA			FA	
	3B			7B			BB			FB	
	3C			7C			BC			FC	
	3D			7D			BD		DAC_CR	FD	RW
	3E			7E			BE		CPU_SCR1	FE	#
	3F			7F			BF		CPU_SCR0	FF	#

Blank fields are Reserved and should not be accessed.

Access is bit specific.

9. Electrical Specifications

This section presents the DC and AC electrical specifications of the CY8C24x94 PSoC device family. For the most up to date electrical specifications, confirm that you have the most recent data sheet by going to the web at <http://www.cypress.com/psoc>.

Specifications are valid for $-40^{\circ}\text{C} \leq T_A \leq 85^{\circ}\text{C}$ and $T_J \leq 100^{\circ}\text{C}$, except where noted. Specifications for devices running at greater than 12 MHz are valid for $-40^{\circ}\text{C} \leq T_A \leq 70^{\circ}\text{C}$ and $T_J \leq 82^{\circ}\text{C}$.

Figure 9-1. Voltage versus CPU Frequency

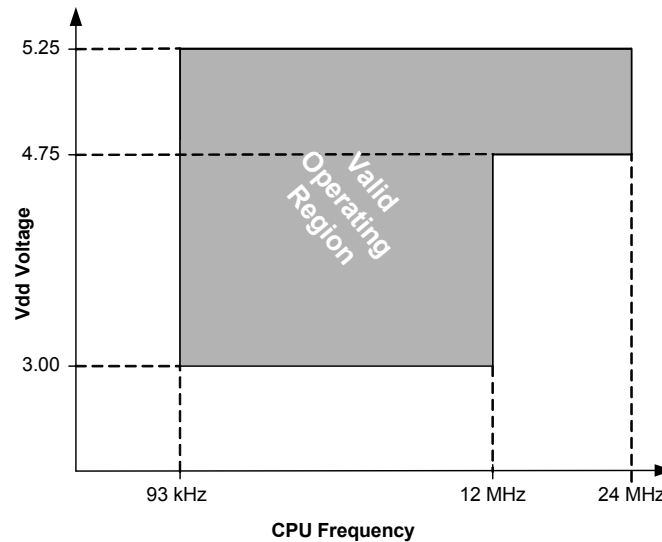

The following table lists the units of measure that are used in this chapter.

Table 9-1. Units of Measure

Symbol	Unit of Measure	Symbol	Unit of Measure
$^{\circ}\text{C}$	degree Celsius	μW	microwatts
dB	decibels	mA	milli-ampere
fF	femto farad	ms	milli-second
Hz	hertz	mV	milli-volts
KB	1024 bytes	nA	nanoampere
Kbit	1024 bits	ns	nanosecond
kHz	kilohertz	nV	nanovolts
k Ω	kilohm	W	ohm
MHz	megahertz	pA	picoampere
M Ω	megaohm	pF	picofarad
μA	microampere	pp	peak-to-peak
μF	microfarad	ppm	parts per million
μH	microhenry	ps	picosecond
μs	microsecond	sps	samples per second
μV	microvolts	s	sigma: one standard deviation
μV_{rms}	microvolts root-mean-square	V	volts

9.1 Absolute Maximum Ratings

Table 9-2. Absolute Maximum Ratings

Symbol	Description	Min	Typ	Max	Units	Notes
T _{STG}	Storage Temperature	-55	25	+100	°C	Higher storage temperatures reduces data retention time. Recommended storage temperature is +25°C ± 25°C. Extended duration storage temperatures above 65°C degrades reliability.
T _A	Ambient Temperature with Power Applied	-40	–	+85	°C	
V _{DD}	Supply Voltage on Vdd Relative to Vss	-0.5	–	+6.0	V	
V _{I/O}	DC Input Voltage	V _{SS} - 0.5	–	V _{DD} + 0.5	V	
V _{I/O2}	DC Voltage Applied to Tri-state	V _{SS} - 0.5	–	V _{DD} + 0.5	V	
I _{MI/O}	Maximum Current into any Port Pin	-25	–	+50	mA	
I _{MAI/O}	Maximum Current into any Port Pin Configured as Analog Driver	-50	–	+50	mA	
ESD	Electro Static Discharge Voltage	2000	–	–	V	Human Body Model ESD.
LU	Latch-up Current	–	–	200	mA	

9.2 Operating Temperature

Table 9-3. Operating Temperature

Symbol	Description	Min	Typ	Max	Units	Notes
T _A	Ambient Temperature	-40	–	+85	°C	
T _{AUSB}	Ambient Temperature using USB	-10	–	+85	°C	
T _J	Junction Temperature	-40	–	+100	°C	The temperature rise from ambient to junction is package specific. See Thermal Impedance on page 41. The user must limit the power consumption to comply with this requirement.

9.3 DC Electrical Characteristics

9.3.1 DC Chip Level Specifications

The following table lists guaranteed maximum and minimum specifications for the voltage and temperature ranges: 4.75V to 5.25V and $-40^{\circ}\text{C} \leq T_A \leq 85^{\circ}\text{C}$, or 3.0V to 3.6V and $-40^{\circ}\text{C} \leq T_A \leq 85^{\circ}\text{C}$, respectively. Typical parameters apply to 5V and 3.3V at 25°C and are for design guidance only.

Table 9-4. DC Chip-Level Specifications

Symbol	Description	Min	Typ	Max	Units	Notes
V _{DD}	Supply Voltage	3.0	–	5.25	V	See DC POR and LVD specifications, Table 9-14 on page 28 .
I _{DD5}	Supply Current, IMO = 24 MHz (5V)	–	14	27	mA	Conditions are V _{DD} = 5.0V, T _A = 25°C, CPU = 3 MHz, SYSCLK doubler disabled, VC1 = 1.5 MHz, VC2 = 93.75 kHz, VC3 = 93.75 kHz, analog power = off.
I _{DD3}	Supply Current, IMO = 24 MHz (3.3V)	–	8	14	mA	Conditions are V _{DD} = 3.3V, T _A = 25°C, CPU = 3 MHz, SYSCLK doubler disabled, VC1 = 1.5 MHz, VC2 = 93.75 kHz, VC3 = 0.367 kHz, analog power = off.
I _{SB}	Sleep (Mode) Current with POR, LVD, Sleep Timer, and WDT. ^[3]	–	3	6.5	μA	Conditions are with internal slow speed oscillator, V _{DD} = 3.3V, $-40^{\circ}\text{C} \leq T_A \leq 55^{\circ}\text{C}$, analog power = off.
I _{SBH}	Sleep (Mode) Current with POR, LVD, Sleep Timer, and WDT at high temperature. ^[3]	–	4	25	μA	Conditions are with internal slow speed oscillator, V _{DD} = 3.3V, $55^{\circ}\text{C} < T_A \leq 85^{\circ}\text{C}$, analog power = off.

9.3.2 DC General Purpose I/O Specifications

The following table lists guaranteed maximum and minimum specifications for the voltage and temperature ranges: 4.75V to 5.25V and $-40^{\circ}\text{C} \leq T_A \leq 85^{\circ}\text{C}$, or 3.0V to 3.6V and $-40^{\circ}\text{C} \leq T_A \leq 85^{\circ}\text{C}$, respectively. Typical parameters apply to 5V and 3.3V at 25°C and are for design guidance only.

Table 9-5. DC GPI/O Specifications

Symbol	Description	Min	Typ	Max	Units	Notes
R _{PU}	Pull Up Resistor	4	5.6	8	kΩ	
R _{PD}	Pull Down Resistor	4	5.6	8	kΩ	
V _{OH}	High Output Level	V _{DD} - 1.0	–	–	V	I/OH = 10 mA, V _{DD} = 4.75 to 5.25V (8 total loads, 4 on even port pins (for example, P0[2], P1[4]), 4 on odd port pins (for example, P0[3], P1[5])). 80 mA maximum combined I/OH budget.
V _{OL}	Low Output Level	–	–	0.75	V	I/OL = 25 mA, V _{DD} = 4.75 to 5.25V (8 total loads, 4 on even port pins (for example, P0[2], P1[4]), 4 on odd port pins (for example, P0[3], P1[5])). 200 mA maximum combined I/OL budget.
V _{IL}	Input Low Level	–	–	0.8	V	V _{DD} = 3.0 to 5.25.
V _{IH}	Input High Level	2.1	–	–	V	V _{DD} = 3.0 to 5.25.
V _H	Input Hysteresis	–	60	–	mV	
I _{IL}	Input Leakage (Absolute Value)	–	1	–	nA	Gross tested to 1 μA.
C _{IN}	Capacitive Load on Pins as Input	–	3.5	10	pF	Package and pin dependent. Temp = 25°C.
C _{OUT}	Capacitive Load on Pins as Output	–	3.5	10	pF	Package and pin dependent. Temp = 25°C.

Note

- Standby current includes all functions (POR, LVD, WDT, Sleep Time) needed for reliable system operation. This should be compared with devices that have similar functions enabled.

9.3.3 DC Full Speed USB Specifications

The following table lists guaranteed maximum and minimum specifications for the voltage and temperature ranges: 4.75V to 5.25V and $-10^{\circ}\text{C} \leq T_A \leq 85^{\circ}\text{C}$, or 3.0V to 3.6V and $-10^{\circ}\text{C} \leq T_A \leq 85^{\circ}\text{C}$, respectively. Typical parameters apply to 5V and 3.3V at 25°C and are for design guidance only.

Table 9-6. DC Full Speed (12 Mbps) USB Specifications

Symbol	Description	Min	Typ	Max	Units	Notes
USB Interface						
V _{DI}	Differential Input Sensitivity	0.2	–	–	V	(D+) - (D-)
V _{CM}	Differential Input Common Mode Range	0.8	–	2.5	V	
V _{SE}	Single Ended Receiver Threshold	0.8	–	2.0	V	
C _{IN}	Transceiver Capacitance	–	–	20	pF	
I _{I/O}	High-Z State Data Line Leakage	-10	–	10	μA	0V < V _{IN} < 3.3V.
R _{EXT}	External USB Series Resistor	23	–	25	W	In series with each USB pin.
V _{UOH}	Static Output High, Driven	2.8	–	3.6	V	15 kΩ ± 5% to Ground. Internal pull up enabled.
V _{UOHI}	Static Output High, Idle	2.7	–	3.6	V	15 kΩ ± 5% to Ground. Internal pull up enabled.
V _{UOL}	Static Output Low	–	–	0.3	V	15 kΩ ± 5% to Ground. Internal pull up enabled.
Z _O	USB Driver Output Impedance	28	–	44	W	Including R _{EXT} Resistor.
V _{CRS}	D+/D- Crossover Voltage	1.3	–	2.0	V	

9.3.4 DC Operational Amplifier Specifications

The following tables list guaranteed maximum and minimum specifications for the voltage and temperature ranges: 4.75V to 5.25V and $-40^{\circ}\text{C} \leq T_A \leq 85^{\circ}\text{C}$, or 3.0V to 3.6V and $-40^{\circ}\text{C} \leq T_A \leq 85^{\circ}\text{C}$, respectively. Typical parameters apply to 5V and 3.3V at 25°C and are for design guidance only.

The Operational Amplifier is a component of both the Analog Continuous Time PSoC blocks and the Analog Switched Capacitor PSoC blocks. The guaranteed specifications are measured in the Analog Continuous Time PSoC block.

Table 9-7. 5V DC Operational Amplifier Specifications

Symbol	Description	Min	Typ	Max	Units	Notes
V _{OSOA}	Input Offset Voltage (absolute value) Power = Low, Opamp Bias = High Power = Medium, Opamp Bias = High Power = High, Opamp Bias = High	–	1.6	10	mV	
		–	1.3	8	mV	
		–	1.2	7.5	mV	
TCV _{OSOA}	Average Input Offset Voltage Drift	–	7.0	35.0	μV/°C	
I _{EBOA}	Input Leakage Current (Port 0 Analog Pins)	–	20	–	pA	Gross tested to 1 μA.
C _{INOA}	Input Capacitance (Port 0 Analog Pins)	–	4.5	9.5	pF	Package and pin dependent. Temp = 25°C.
V _{CMOA}	Common Mode Voltage Range	0.0	–	V _{DD}	V	The common-mode input voltage range is measured through an analog output buffer. The specification includes the limitations imposed by the characteristics of the analog output buffer.
	Common Mode Voltage Range (high power or high opamp bias)	0.5	–	V _{DD} - 0.5		
G _{OLOA}	Open Loop Gain Power = Low, Opamp Bias = High Power = Medium, Opamp Bias = High Power = High, Opamp Bias = High	60	–	–	dB	
		60				
		80				

Table 9-7. 5V DC Operational Amplifier Specifications (continued)

Symbol	Description	Min	Typ	Max	Units	Notes
V _{OHIGHOA}	High Output Voltage Swing (internal signals)					
	Power = Low, Opamp Bias = High	V _{dd} - 0.2	–	–	V	
	Power = Medium, Opamp Bias = High	V _{dd} - 0.2	–	–	V	
	Power = High, Opamp Bias = High	V _{dd} - 0.5	–	–	V	
V _{LOWOA}	Low Output Voltage Swing (internal signals)					
	Power = Low, Opamp Bias = High	–	–	0.2	V	
	Power = Medium, Opamp Bias = High	–	–	0.2	V	
	Power = High, Opamp Bias = High	–	–	0.5	V	
I _{SOA}	Supply Current (including associated AGND buffer)	–	400	800	μA	
	Power = Low, Opamp Bias = Low	–	500	900	μA	
	Power = Low, Opamp Bias = High	–	800	1000	μA	
	Power = Medium, Opamp Bias = Low	–	1200	1600	μA	
	Power = Medium, Opamp Bias = High	–	2400	3200	μA	
	Power = High, Opamp Bias = Low	–	4600	6400	μA	
	Power = High, Opamp Bias = High	–	4600	6400	μA	
PSRR _{OA}	Supply Voltage Rejection Ratio	65	80	–	dB	V _{ss} ≤ VIN ≤ (V _{dd} - 2.25) or (V _{dd} - 1.25V) ≤ VIN ≤ V _{dd} .

9.3.5 DC Low Power Comparator Specifications

The following table lists guaranteed maximum and minimum specifications for the voltage and temperature ranges: 4.75V to 5.25V and -40°C ≤ T_A ≤ 85°C, 3.0V to 3.6V and -40°C ≤ T_A ≤ 85°C, or 2.4V to 3.0V and -40°C ≤ T_A ≤ 85°C, respectively. Typical parameters apply to 5V at 25°C and are for design guidance only.

Table 9-8. DC Low Power Comparator Specifications

Symbol	Description	Min	Typ	Max	Units	Notes
V _{REFLPC}	Low power comparator (LPC) reference voltage range	0.2	–	V _{dd} - 1	V	
I _{SLPC}	LPC supply current	–	10	40	μA	
V _{OSLPC}	LPC voltage offset	–	2.5	30	mV	

9.3.6 DC Analog Output Buffer Specifications

The following tables list guaranteed maximum and minimum specifications for the voltage and temperature ranges: 4.75V to 5.25V and $-40^{\circ}\text{C} \leq T_A \leq 85^{\circ}\text{C}$, or 3.0V to 3.6V and $-40^{\circ}\text{C} \leq T_A \leq 85^{\circ}\text{C}$, respectively. Typical parameters apply to 5V and 3.3V at 25°C and are for design guidance only.

Table 9-9. 5V DC Analog Output Buffer Specifications

Symbol	Description	Min	Typ	Max	Units	Notes
V_{OSOB}	Input Offset Voltage (Absolute Value)	–	3	12	mV	
TCV_{OSOB}	Average Input Offset Voltage Drift	–	+6	–	$\mu\text{V}/^{\circ}\text{C}$	
V_{CMOB}	Common-Mode Input Voltage Range	0.5	–	Vdd - 1.0	V	
R_{OUTOB}	Output Resistance Power = Low Power = High	– –	0.6 0.6	– –	W W	
$V_{OHIGHOB}$	High Output Voltage Swing (Load = 32 ohms to Vdd/2) Power = Low Power = High	$0.5 \times V_{dd} + 1.1$ $0.5 \times V_{dd} + 1.1$	– –	– –	V V	
V_{OLOWOB}	Low Output Voltage Swing (Load = 32 ohms to Vdd/2) Power = Low Power = High	– –	– –	$0.5 \times V_{dd} - 1.3$ $0.5 \times V_{dd} - 1.3$	V V	
I_{SOB}	Supply Current Including Bias Cell (No Load) Power = Low Power = High	– –	1.1 2.6	5.1 8.8	mA mA	
$PSRR_{OB}$	Supply Voltage Rejection Ratio	53	64	–	dB	$(0.5 \times V_{dd} - 1.3) \leq V_{OUT} \leq (V_{dd} - 2.3)$.

Table 9-10. 3.3V DC Analog Output Buffer Specifications

Symbol	Description	Min	Typ	Max	Units	Notes
V_{OSOB}	Input Offset Voltage (Absolute Value)	–	3	12	mV	
TCV_{OSOB}	Average Input Offset Voltage Drift	–	+6	–	$\mu\text{V}/^{\circ}\text{C}$	
V_{CMOB}	Common-Mode Input Voltage Range	0.5	–	Vdd - 1.0	V	
R_{OUTOB}	Output Resistance Power = Low Power = High	– –	1 1	– –	W W	
$V_{OHIGHOB}$	High Output Voltage Swing (Load = 1K ohms to Vdd/2) Power = Low Power = High	$0.5 \times V_{dd} + 1.0$ $0.5 \times V_{dd} + 1.0$	– –	– –	V V	
V_{OLOWOB}	Low Output Voltage Swing (Load = 1K ohms to Vdd/2) Power = Low Power = High	– –	– –	$0.5 \times V_{dd} - 1.0$ $0.5 \times V_{dd} - 1.0$	V V	
I_{SOB}	Supply Current Including Bias Cell (No Load) Power = Low Power = High	– –	0.8 2.0	2.0 4.3	mA mA	
$PSRR_{OB}$	Supply Voltage Rejection Ratio	34	64	–	dB	$(0.5 \times V_{dd} - 1.0) \leq V_{OUT} \leq (0.5 \times V_{dd} + 0.9)$.

9.3.7 DC Analog Reference Specifications

The following tables list guaranteed maximum and minimum specifications for the voltage and temperature ranges: 4.75V to 5.25V and $-40^{\circ}\text{C} \leq T_A \leq 85^{\circ}\text{C}$, or 3.0V to 3.6V and $-40^{\circ}\text{C} \leq T_A \leq 85^{\circ}\text{C}$, respectively. Typical parameters apply to 5V and 3.3V at 25°C and are for design guidance only.

The guaranteed specifications are measured through the Analog Continuous Time PSoC blocks. The power levels for AGND refer to the power of the Analog Continuous Time PSoC block. The power levels for RefHi and RefLo refer to the Analog Reference Control register. The limits stated for AGND include the offset error of the AGND buffer local to the Analog Continuous Time PSoC block. Reference control power is high.

Table 9-11. 5V DC Analog Reference Specifications

Symbol	Description	Min	Typ	Max	Units
BG	Bandgap Voltage Reference	1.28	1.30	1.32	V
–	AGND = $V_{dd}/2^{[4, 5]}$	$V_{dd}/2 - 0.04$	$V_{dd}/2 - 0.01$	$V_{dd}/2 + 0.007$	V
–	AGND = $2 \times \text{BandGap}^{[4, 5]}$	$2 \times \text{BG} - 0.048$	$2 \times \text{BG} - 0.030$	$2 \times \text{BG} + 0.024$	V
–	AGND = P2[4] (P2[4] = $V_{dd}/2$) ^[4, 5]	P2[4] - 0.011	P2[4]	P2[4] + 0.011	V
–	AGND = BandGap ^[4, 5]	BG - 0.009	BG + 0.008	BG + 0.016	V
–	AGND = $1.6 \times \text{BandGap}^{[4, 5]}$	$1.6 \times \text{BG} - 0.022$	$1.6 \times \text{BG} - 0.010$	$1.6 \times \text{BG} + 0.018$	V
–	AGND Block to Block Variation (AGND = $V_{dd}/2$) ^[4, 5]	-0.034	0.000	0.034	V
–	RefHi = $V_{dd}/2 + \text{BandGap}$	$V_{dd}/2 + \text{BG} - 0.10$	$V_{dd}/2 + \text{BG}$	$V_{dd}/2 + \text{BG} + 0.10$	V
–	RefHi = $3 \times \text{BandGap}$	$3 \times \text{BG} - 0.06$	$3 \times \text{BG}$	$3 \times \text{BG} + 0.06$	V
–	RefHi = $2 \times \text{BandGap} + \text{P2}[6]$ (P2[6] = 1.3V)	$2 \times \text{BG} + \text{P2}[6] - 0.113$	$2 \times \text{BG} + \text{P2}[6] - 0.018$	$2 \times \text{BG} + \text{P2}[6] + 0.077$	V
–	RefHi = P2[4] + BandGap (P2[4] = $V_{dd}/2$)	P2[4] + BG - 0.130	P2[4] + BG - 0.016	P2[4] + BG + 0.098	V
–	RefHi = P2[4] + P2[6] (P2[4] = $V_{dd}/2$, P2[6] = 1.3V)	P2[4] + P2[6] - 0.133	P2[4] + P2[6] - 0.016	P2[4] + P2[6] + 0.100	V
–	RefHi = $3.2 \times \text{BandGap}$	$3.2 \times \text{BG} - 0.112$	$3.2 \times \text{BG}$	$3.2 \times \text{BG} + 0.076$	V
–	RefLo = $V_{dd}/2 - \text{BandGap}$	$V_{dd}/2 - \text{BG} - 0.04$	$V_{dd}/2 - \text{BG} + 0.024$	$V_{dd}/2 - \text{BG} + 0.04$	V
–	RefLo = BandGap	BG - 0.06	BG	BG + 0.06	V
–	RefLo = $2 \times \text{BandGap} - \text{P2}[6]$ (P2[6] = 1.3V)	$2 \times \text{BG} - \text{P2}[6] - 0.084$	$2 \times \text{BG} - \text{P2}[6] + 0.025$	$2 \times \text{BG} - \text{P2}[6] + 0.134$	V
–	RefLo = P2[4] - BandGap (P2[4] = $V_{dd}/2$)	P2[4] - BG - 0.056	P2[4] - BG + 0.026	P2[4] - BG + 0.107	V
–	RefLo = P2[4] - P2[6] (P2[4] = $V_{dd}/2$, P2[6] = 1.3V)	P2[4] - P2[6] - 0.057	P2[4] - P2[6] + 0.026	P2[4] - P2[6] + 0.110	V

Table 9-12. 3.3V DC Analog Reference Specifications

Symbol	Description	Min	Typ	Max	Units
BG	Bandgap Voltage Reference	1.28	1.30	1.32	V
–	AGND = $V_{dd}/2^{[4, 5]}$	$V_{dd}/2 - 0.03$	$V_{dd}/2 - 0.01$	$V_{dd}/2 + 0.005$	V
–	AGND = $2 \times \text{BandGap}^{[4, 5]}$	Not Allowed			
–	AGND = P2[4] (P2[4] = $V_{dd}/2$)	P2[4] - 0.008	P2[4] + 0.001	P2[4] + 0.009	V
–	AGND = BandGap ^[4, 5]	BG - 0.009	BG + 0.005	BG + 0.015	V
–	AGND = $1.6 \times \text{BandGap}^{[4, 5]}$	$1.6 \times \text{BG} - 0.027$	$1.6 \times \text{BG} - 0.010$	$1.6 \times \text{BG} + 0.018$	V
–	AGND Column to Column Variation (AGND = $V_{dd}/2$) ^[4, 5]	-0.034	0.000	0.034	V
–	RefHi = $V_{dd}/2 + \text{BandGap}$	Not Allowed			
–	RefHi = $3 \times \text{BandGap}$	Not Allowed			
–	RefHi = $2 \times \text{BandGap} + \text{P2}[6]$ (P2[6] = 0.5V)	Not Allowed			
–	RefHi = P2[4] + BandGap (P2[4] = $V_{dd}/2$)	Not Allowed			
–	RefHi = P2[4] + P2[6] (P2[4] = $V_{dd}/2$, P2[6] = 0.5V)	P2[4] + P2[6] - 0.075	P2[4] + P2[6] - 0.009	P2[4] + P2[6] + 0.057	V

Table 9-12. 3.3V DC Analog Reference Specifications (continued)

Symbol	Description	Min	Typ	Max	Units
–	RefHi = 3.2 x BandGap		Not Allowed		
–	RefLo = Vdd/2 - BandGap		Not Allowed		
–	RefLo = BandGap		Not Allowed		
–	RefLo = 2 x BandGap - P2[6] (P2[6] = 0.5V)		Not Allowed		
–	RefLo = P2[4] – BandGap (P2[4] = Vdd/2)		Not Allowed		
–	RefLo = P2[4]-P2[6] (P2[4] = Vdd/2, P2[6] = 0.5V)	P2[4] - P2[6] - 0.048	P2[4]- P2[6] + 0.022	P2[4] - P2[6] + 0.092	V

9.3.8 DC Analog PSoC Block Specifications

The following table lists guaranteed maximum and minimum specifications for the voltage and temperature ranges: 4.75V to 5.25V and $-40^{\circ}\text{C} \leq T_A \leq 85^{\circ}\text{C}$, or 3.0V to 3.6V and $-40^{\circ}\text{C} \leq T_A \leq 85^{\circ}\text{C}$, respectively. Typical parameters apply to 5V and 3.3V at 25°C and are for design guidance only.

Table 9-13. DC Analog PSoC Block Specifications

Symbol	Description	Min	Typ	Max	Units	Notes
R _{CT}	Resistor Unit Value (Continuous Time)	–	12.2	–	kΩ	
C _{SC}	Capacitor Unit Value (Switched Capacitor)	–	80	–	fF	

Note

- AGND tolerance includes the offsets of the local buffer in the PSoC block. Bandgap voltage is $1.3\text{V} \pm 0.02\text{V}$.
- Avoid using P2[4] for digital signaling when using an analog resource that depends on the Analog Reference. Some coupling of the digital signal may appear on the AGND.

9.3.9 DC POR and LVD Specifications

The following table lists guaranteed maximum and minimum specifications for the voltage and temperature ranges: 4.75V to 5.25V and $-40^{\circ}\text{C} \leq T_A \leq 85^{\circ}\text{C}$, or 3.0V to 3.6V and $-40^{\circ}\text{C} \leq T_A \leq 85^{\circ}\text{C}$, respectively. Typical parameters apply to 5V or 3.3V at 25°C and are for design guidance only.

Note The bits PORLEV and VM in the following table refer to bits in the VLT_CR register. See the *PSoC Programmable System-on-Chip Technical Reference Manual* for more information on the VLT_CR register.

Table 9-14. DC POR and LVD Specifications

Symbol	Description	Min	Typ	Max	Units	Notes
V _{PPOR0R}	Vdd Value for PPOR Trip (positive ramp) PORLEV[1:0] = 00b		2.91		V	
V _{PPOR1R}	PORLEV[1:0] = 01b	–	4.39	–	V	
V _{PPOR2R}	PORLEV[1:0] = 10b		4.55		V	
V _{PPOR0}	Vdd Value for PPOR Trip (negative ramp) PORLEV[1:0] = 00b		2.82		V	
V _{PPOR1}	PORLEV[1:0] = 01b	–	4.39	–	V	
V _{PPOR2}	PORLEV[1:0] = 10b		4.55		V	
V _{PH0}	PPOR Hysteresis PORLEV[1:0] = 00b	–	92	–	mV	
V _{PH1}	PORLEV[1:0] = 01b	–	0	–	mV	
V _{PH2}	PORLEV[1:0] = 10b	–	0	–	mV	
V _{LVD0}	Vdd Value for LVD Trip VM[2:0] = 000b	2.86	2.92	2.98 ^[6]	V	
V _{LVD1}	VM[2:0] = 001b	2.96	3.02	3.08	V	
V _{LVD2}	VM[2:0] = 010b	3.07	3.13	3.20	V	
V _{LVD3}	VM[2:0] = 011b	3.92	4.00	4.08	V	
V _{LVD4}	VM[2:0] = 100b	4.39	4.48	4.57	V	
V _{LVD5}	VM[2:0] = 101b	4.55	4.64	4.74 ^[7]	V	
V _{LVD6}	VM[2:0] = 110b	4.63	4.73	4.82	V	
V _{LVD7}	VM[2:0] = 111b	4.72	4.81	4.91	V	

Notes

- 6. Always greater than 50 mV above PPOR (PORLEV = 00) for falling supply.
- 7. Always greater than 50 mV above PPOR (PORLEV = 10) for falling supply.

9.3.10 DC Programming Specifications

The following table lists guaranteed maximum and minimum specifications for the voltage and temperature ranges: 4.75V to 5.25V and $-40^{\circ}\text{C} \leq T_A \leq 85^{\circ}\text{C}$, or 3.0V to 3.6V and $-40^{\circ}\text{C} \leq T_A \leq 85^{\circ}\text{C}$, respectively. Typical parameters apply to 5V and 3.3V at 25°C and are for design guidance only.

Table 9-15. DC Programming Specifications

Symbol	Description	Min	Typ	Max	Units	Notes
I_{DDP}	Supply Current During Programming or Verify	–	15	30	mA	
V_{ILP}	Input Low Voltage During Programming or Verify	–	–	0.8	V	
V_{IHP}	Input High Voltage During Programming or Verify	2.1	–	–	V	
I_{ILP}	Input Current when Applying V_{ilp} to P1[0] or P1[1] During Programming or Verify	–	–	0.2	mA	Driving internal pull down resistor.
I_{IHP}	Input Current when Applying V_{ihp} to P1[0] or P1[1] During Programming or Verify	–	–	1.5	mA	Driving internal pull down resistor.
V_{OLV}	Output Low Voltage During Programming or Verify	–	–	$V_{SS} + 0.75$	V	
V_{OHV}	Output High Voltage During Programming or Verify	$V_{DD} - 1.0$	–	V_{DD}	V	
Flash_{ENPB}	Flash Endurance (per block)	50,000	–	–	–	Erase/write cycles per block.
Flash_{ENT}	Flash Endurance (total) ^[8]	1,800,000	–	–	–	Erase/write cycles.
Flash_{DR}	Flash Data Retention	10	–	–	Years	

Note

8. A maximum of 36 x 50,000 block endurance cycles is allowed. This may be balanced between operations on 36x1 blocks of 50,000 maximum cycles each, 36x2 blocks of 25,000 maximum cycles each, or 36x4 blocks of 12,500 maximum cycles each (to limit the total number of cycles to 36x50,000 and that no single block ever sees more than 50,000 cycles).
 For the full industrial range, the user must employ a temperature sensor user module (FlashTemp) and feed the result to the temperature argument before writing. Refer to the Flash APIs Application Note AN2015 at <http://www.cypress.com> under Application Notes for more information.

9.4 AC Electrical Characteristics

9.4.1 AC Chip-Level Specifications

The following table lists guaranteed maximum and minimum specifications for the voltage and temperature ranges: 4.75V to 5.25V and $-40^{\circ}\text{C} \leq T_A \leq 85^{\circ}\text{C}$, or 3.0V to 3.6V and $-40^{\circ}\text{C} \leq T_A \leq 85^{\circ}\text{C}$, respectively. Typical parameters apply to 5V and 3.3V at 25°C and are for design guidance only.

Table 9-16. AC Chip-Level Specifications

Symbol	Description	Min	Typ	Max	Units	Notes
F _{IMO245V}	Internal Main Oscillator Frequency for 24 MHz (5V)	23.04	24	24.96 ^[9,10]	MHz	Trimmed for 5V operation using factory trim values.
F _{IMO243V}	Internal Main Oscillator Frequency for 24 MHz (3.3V)	22.08	24	25.92 ^[10,11]	MHz	Trimmed for 3.3V operation using factory trim values.
F _{IMOUSB5V}	Internal Main Oscillator Frequency with USB (5V) Frequency locking enabled and USB traffic present.	23.94	24	24.06 ^[10]	MHz	$-10^{\circ}\text{C} \leq T_A \leq 85^{\circ}\text{C}$ $4.35 \leq V_{dd} \leq 5.15$
F _{IMOUSB3V}	Internal Main Oscillator Frequency with USB (3.3V) Frequency locking enabled and USB traffic present.	23.94	24	24.06 ^[10]	MHz	$-0^{\circ}\text{C} \leq T_A \leq 70^{\circ}\text{C}$ $3.15 \leq V_{dd} \leq 3.45$
F _{CPU1}	CPU Frequency (5V Nominal)	0.93	24	24.96 ^[9,10]	MHz	
F _{CPU2}	CPU Frequency (3.3V Nominal)	0.93	12	12.96 ^[10,11]	MHz	
F _{BLK5}	Digital PSoC Block Frequency (5V Nominal)	0	48	49.92 ^[9,10,12]	MHz	Refer to the AC Digital Block Specifications.
F _{BLK3}	Digital PSoC Block Frequency (3.3V Nominal)	0	24	25.92 ^[10,12]	MHz	
F _{32K1}	Internal Low Speed Oscillator Frequency	15	32	64	kHz	
Jitter32k	32 kHz Period Jitter	–	100		ns	
Step24M	24 MHz Trim Step Size	–	50	–	kHz	
F _{out48M}	48 MHz Output Frequency	46.08	48.0	49.92 ^[9,11]	MHz	Trimmed. Utilizing factory trim values.
Jitter24M1	24 MHz Period Jitter (IMO) Peak-to-Peak	–	300		ps	
F _{MAX}	Maximum frequency of signal on row input or row output.	–	–	12.96	MHz	
T _{RAMP}	Supply Ramp Time	0	–	–	μs	

Figure 9-2. 24 MHz Period Jitter (IMO) Timing Diagram

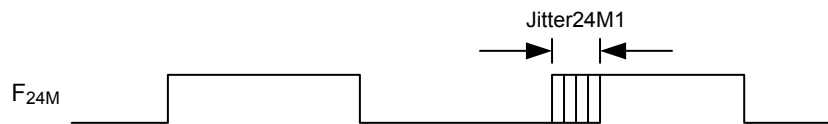

Notes

9. 4.75V < V_{dd} < 5.25V.

10. Accuracy derived from Internal Main Oscillator with appropriate trim for V_{dd} range.

11. 3.0V < V_{dd} < 3.6V. See Application Note AN2012 "Adjusting PSoC Microcontroller Trims for Dual Voltage-Range Operation" for information on trimming for operation at 3.3V.

12. See the individual user module data sheets for information on maximum frequencies for user modules

9.4.2 AC General Purpose I/O Specifications

The following table lists guaranteed maximum and minimum specifications for the voltage and temperature ranges: 4.75V to 5.25V and $-40^{\circ}\text{C} \leq T_A \leq 85^{\circ}\text{C}$, or 3.0V to 3.6V and $-40^{\circ}\text{C} \leq T_A \leq 85^{\circ}\text{C}$, respectively. Typical parameters apply to 5V and 3.3V at 25°C and are for design guidance only.

Table 9-17. AC GPIO Specifications

Symbol	Description	Min	Typ	Max	Units	Notes
F_{GPIO}	GPIO Operating Frequency	0	–	12	MHz	Normal Strong Mode
T_{RiseF}	Rise Time, Normal Strong Mode, Load = 50 pF	3	–	18	ns	Vdd = 4.5 to 5.25V, 10% - 90%
T_{FallF}	Fall Time, Normal Strong Mode, Load = 50 pF	2	–	18	ns	Vdd = 4.5 to 5.25V, 10% - 90%
T_{RiseS}	Rise Time, Slow Strong Mode, Load = 50 pF	10	27	–	ns	Vdd = 3 to 5.25V, 10% - 90%
T_{FallS}	Fall Time, Slow Strong Mode, Load = 50 pF	10	22	–	ns	Vdd = 3 to 5.25V, 10% - 90%

Figure 9-3. GPIO Timing Diagram

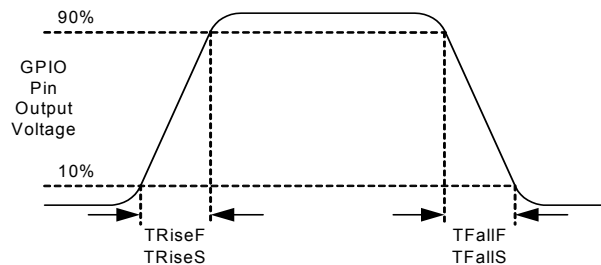

9.4.3 AC Full Speed USB Specifications

The following table lists guaranteed maximum and minimum specifications for the voltage and temperature ranges: 4.75V to 5.25V and $-10^{\circ}\text{C} \leq T_A \leq 85^{\circ}\text{C}$, or 3.0V to 3.6V and $-10^{\circ}\text{C} \leq T_A \leq 85^{\circ}\text{C}$, respectively. Typical parameters apply to 5V and 3.3V at 25°C and are for design guidance only.

Table 9-18. AC Full Speed (12 Mbps) USB Specifications

Symbol	Description	Min	Typ	Max	Units	Notes
T_{RFS}	Transition Rise Time	4	–	20	ns	For 50 pF load.
T_{FSS}	Transition Fall Time	4	–	20	ns	For 50 pF load.
T_{RFMFS}	Rise/Fall Time Matching: (T_R/T_F)	90	–	111	%	For 50 pF load.
T_{DRATEFS}	Full Speed Data Rate	12 - 0.25%	12	12 + 0.25%	Mbps	

9.4.4 AC Operational Amplifier Specifications

The following tables list guaranteed maximum and minimum specifications for the voltage and temperature ranges: 4.75V to 5.25V and $-40^{\circ}\text{C} \leq T_A \leq 85^{\circ}\text{C}$, or 3.0V to 3.6V and $-40^{\circ}\text{C} \leq T_A \leq 85^{\circ}\text{C}$, respectively. Typical parameters apply to 5V and 3.3V at 25°C and are for design guidance only.

Settling times, slew rates, and gain bandwidth are based on the Analog Continuous Time PSoC block.

Power = High and Opamp Bias = High is not supported at 3.3V.

Table 9-19. 5V AC Operational Amplifier Specifications

Symbol	Description	Min	Typ	Max	Units
T _{ROA}	Rising Settling Time from 80% of ΔV to 0.1% of ΔV (10 pF load, Unity Gain)				
	Power = Low, Opamp Bias = Low	–	–	3.9	μs
	Power = Medium, Opamp Bias = High	–	–	0.72	μs
T _{SOA}	Falling Settling Time from 20% of ΔV to 0.1% of ΔV (10 pF load, Unity Gain)				
	Power = Low, Opamp Bias = Low	–	–	5.9	μs
	Power = Medium, Opamp Bias = High	–	–	0.92	μs
SR _{ROA}	Rising Slew Rate (20% to 80%)(10 pF load, Unity Gain)				
	Power = Low, Opamp Bias = Low	0.15	–	–	V/ μs
	Power = Medium, Opamp Bias = High	1.7	–	–	V/ μs
SR _{FOA}	Falling Slew Rate (20% to 80%)(10 pF load, Unity Gain)				
	Power = Low, Opamp Bias = Low	0.01	–	–	V/ μs
	Power = Medium, Opamp Bias = High	0.5	–	–	V/ μs
BW _{OA}	Gain Bandwidth Product				
	Power = Low, Opamp Bias = Low	0.75	–	–	MHz
	Power = Medium, Opamp Bias = High	3.1	–	–	MHz
E _{NOA}	Noise at 1 kHz (Power = Medium, Opamp Bias = High)				
		–	100	–	nV/rt-Hz

Table 9-20. 3.3V AC Operational Amplifier Specifications

Symbol	Description	Min	Typ	Max	Units
T _{ROA}	Rising Settling Time from 80% of ΔV to 0.1% of ΔV (10 pF load, Unity Gain)				
	Power = Low, Opamp Bias = Low	–	–	3.92	μs
T _{SOA}	Falling Settling Time from 20% of ΔV to 0.1% of ΔV (10 pF load, Unity Gain)				
	Power = Low, Opamp Bias = Low	–	–	5.41	μs
SR _{ROA}	Rising Slew Rate (20% to 80%)(10 pF load, Unity Gain)				
	Power = Low, Opamp Bias = Low	0.31	–	–	V/ μs
SR _{FOA}	Falling Slew Rate (20% to 80%)(10 pF load, Unity Gain)				
	Power = Low, Opamp Bias = Low	1.8	–	–	V/ μs
BW _{OA}	Gain Bandwidth Product				
	Power = Low, Opamp Bias = Low	0.67	–	–	MHz
E _{NOA}	Noise at 1 kHz (Power = Medium, Opamp Bias = High)				
		–	100	–	nV/rt-Hz

When bypassed by a capacitor on P2[4], the noise of the analog ground signal distributed to each block is reduced by a factor of up to 5 (14 dB). This is at frequencies above the corner frequency defined by the on-chip 8.1k resistance and the external capacitor.

Figure 9-4. Typical AGND Noise with P2[4] Bypass

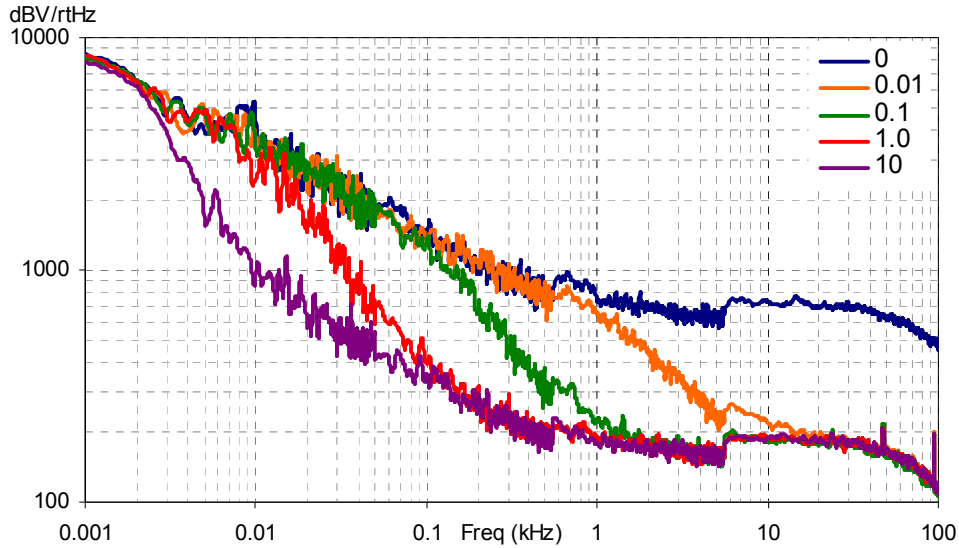

At low frequencies, the opamp noise is proportional to $1/f$, power independent, and determined by device geometry. At high frequencies, increased power level reduces the noise spectrum level.

Figure 9-5. Typical Opamp Noise

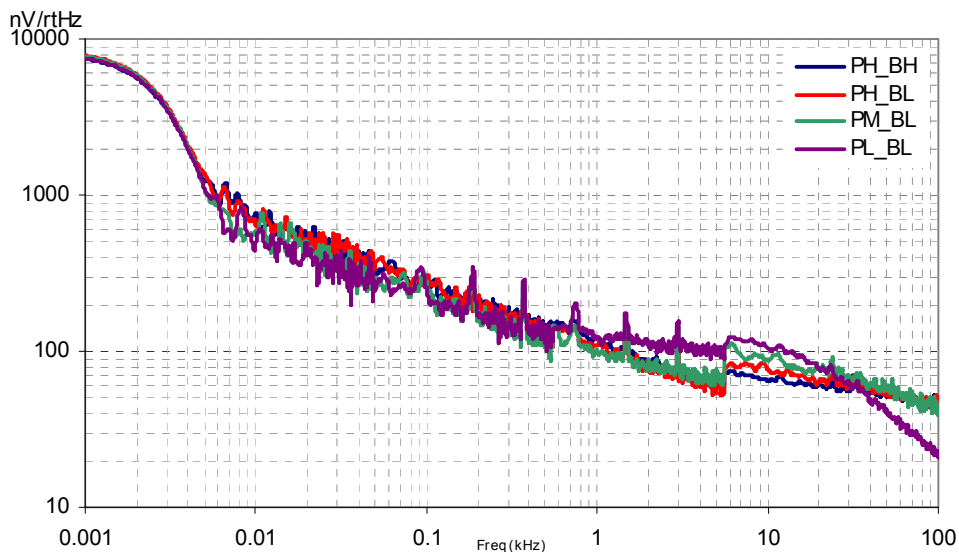

9.4.5 AC Low Power Comparator Specifications

The following table lists guaranteed maximum and minimum specifications for the voltage and temperature ranges: 4.75V to 5.25V and $-40^{\circ}\text{C} \leq T_A \leq 85^{\circ}\text{C}$, 3.0V to 3.6V and $-40^{\circ}\text{C} \leq T_A \leq 85^{\circ}\text{C}$, or 2.4V to 3.0V and $-40^{\circ}\text{C} \leq T_A \leq 85^{\circ}\text{C}$, respectively. Typical parameters apply to 5V at 25°C and are for design guidance only.

Table 9-21. AC Low Power Comparator Specifications

Symbol	Description	Min	Typ	Max	Units	Notes
T_{RLPC}	LPC response time	–	–	50	μs	≥ 50 mV overdrive comparator reference set within V_{REFLPC} .

9.4.6 AC Digital Block Specifications

The following table lists guaranteed maximum and minimum specifications for the voltage and temperature ranges: 4.75V to 5.25V and $-40^{\circ}\text{C} \leq T_A \leq 85^{\circ}\text{C}$, or 3.0V to 3.6V and $-40^{\circ}\text{C} \leq T_A \leq 85^{\circ}\text{C}$, respectively. Typical parameters apply to 5V and 3.3V at 25°C and are for design guidance only.

Table 9-22. AC Digital Block Specifications

Function	Description	Min	Typ	Max	Units	Notes
Timer	Capture Pulse Width	50 ^[13]	–	–	ns	
	Maximum Frequency, No Capture	–	–	49.92	MHz	4.75V < Vdd < 5.25V.
	Maximum Frequency, With Capture	–	–	25.92	MHz	
Counter	Enable Pulse Width	50 ^[13]	–	–	ns	
	Maximum Frequency, No Enable Input	–	–	49.92	MHz	4.75V < Vdd < 5.25V.
	Maximum Frequency, Enable Input	–	–	25.92	MHz	
Dead Band	Kill Pulse Width:					
	Asynchronous Restart Mode	20	–	–	ns	
	Synchronous Restart Mode	50 ^[13]	–	–	ns	
	Disable Mode	50 ^[13]	–	–	ns	
	Maximum Frequency	–	–	49.92	MHz	4.75V < Vdd < 5.25V.
CRCPRS (PRS Mode)	Maximum Input Clock Frequency	–	–	49.92	MHz	4.75V < Vdd < 5.25V.
CRCPRS (CRC Mode)	Maximum Input Clock Frequency	–	–	24.6	MHz	
SPIM	Maximum Input Clock Frequency	–	–	8.2	MHz	Maximum data rate at 4.1 MHz due to 2 x over clocking.
SPIS	Maximum Input Clock Frequency	–	–	4.1	MHz	
	Width of SS_ Negated Between Transmissions	50 ^[13]	–	–	ns	
Transmitter	Maximum Input Clock Frequency	–	–	24.6	MHz	Maximum data rate at 3.08 MHz due to 8 x over clocking.
Receiver	Maximum Input Clock Frequency	–	–	24.6	MHz	Maximum data rate at 3.08 MHz due to 8 x over clocking.

Note

13. 50 ns minimum input pulse width is based on the input synchronizers running at 24 MHz (42 ns nominal period).

9.4.7 AC External Clock Specifications

The following tables list guaranteed maximum and minimum specifications for the voltage and temperature ranges: 4.75V to 5.25V and $-40^{\circ}\text{C} \leq T_A \leq 85^{\circ}\text{C}$, or 3.0V to 3.6V and $-40^{\circ}\text{C} \leq T_A \leq 85^{\circ}\text{C}$, respectively. Typical parameters apply to 5V and 3.3V at 25°C and are for design guidance only.

Table 9-23. AC External Clock Specifications

Symbol	Description	Min	Typ	Max	Units	Notes
F _{OSCEXT}	Frequency for USB Applications	23.94	24	24.06	MHz	
–	Duty Cycle	47	50	53	%	
–	Power up to IMO Switch	150	–	–	μs	

9.4.8 AC Analog Output Buffer Specifications

The following tables list guaranteed maximum and minimum specifications for the voltage and temperature ranges: 4.75V to 5.25V and $-40^{\circ}\text{C} \leq T_A \leq 85^{\circ}\text{C}$, or 3.0V to 3.6V and $-40^{\circ}\text{C} \leq T_A \leq 85^{\circ}\text{C}$, respectively. Typical parameters apply to 5V and 3.3V at 25°C and are for design guidance only.

Table 9-24. 5V AC Analog Output Buffer Specifications

Symbol	Description	Min	Typ	Max	Units	Notes
T _{ROB}	Rising Settling Time to 0.1%, 1V Step, 100pF Load Power = Low Power = High	– –	– –	2.5 2.5	μs μs	
T _{SOB}	Falling Settling Time to 0.1%, 1V Step, 100pF Load Power = Low Power = High	– –	– –	2.2 2.2	μs μs	
SR _{ROB}	Rising Slew Rate (20% to 80%), 1V Step, 100 pF Load Power = Low Power = High	0.65 0.65	– –	– –	V/μs V/μs	
SR _{FOB}	Falling Slew Rate (80% to 20%), 1V Step, 100 pF Load Power = Low Power = High	0.65 0.65	– –	– –	V/μs V/μs	
BW _{OBSS}	Small Signal Bandwidth, 20mV _{pp} , 3dB BW, 100 pF Load Power = Low Power = High	0.8 0.8	– –	– –	MHz MHz	
BW _{OBLs}	Large Signal Bandwidth, 1V _{pp} , 3dB BW, 100 pF Load Power = Low Power = High	300 300	– –	– –	kHz kHz	

Table 9-25. 3.3V AC Analog Output Buffer Specifications

Symbol	Description	Min	Typ	Max	Units	Notes
T _{ROB}	Rising Settling Time to 0.1%, 1V Step, 100 pF Load	–	–	3.8	μs	
	Power = Low	–	–	3.8	μs	
	Power = High					
T _{SOB}	Falling Settling Time to 0.1%, 1V Step, 100 pF Load	–	–	2.6	μs	
	Power = Low	–	–	2.6	μs	
	Power = High					
SR _{ROB}	Rising Slew Rate (20% to 80%), 1V Step, 100 pF Load	0.5	–	–	V/μs	
	Power = Low	0.5	–	–	V/μs	
	Power = High					
SR _{FOB}	Falling Slew Rate (80% to 20%), 1V Step, 100 pF Load	0.5	–	–	V/μs	
	Power = Low	0.5	–	–	V/μs	
	Power = High					
BW _{OBSS}	Small Signal Bandwidth, 20mV _{pp} , 3dB BW, 100 pF Load	0.7	–	–	MHz	
	Power = Low	0.7	–	–	MHz	
	Power = High					
BW _{OBLs}	Large Signal Bandwidth, 1V _{pp} , 3dB BW, 100 pF Load	200	–	–	kHz	
	Power = Low	200	–	–	kHz	
	Power = High					

9.4.9 AC Programming Specifications

The following table lists guaranteed maximum and minimum specifications for the voltage and temperature ranges: 4.75V to 5.25V and $-40^{\circ}\text{C} \leq T_A \leq 85^{\circ}\text{C}$, or 3.0V to 3.6V and $-40^{\circ}\text{C} \leq T_A \leq 85^{\circ}\text{C}$, respectively. Typical parameters apply to 5V and 3.3V at 25°C and are for design guidance only.

Table 9-26. AC Programming Specifications

Symbol	Description	Min	Typ	Max	Units	Notes
T _{RSCLK}	Rise Time of SCLK	1	–	20	ns	
T _{FSCLK}	Fall Time of SCLK	1	–	20	ns	
T _{SSCLK}	Data Set up Time to Falling Edge of SCLK	40	–	–	ns	
T _{HSCLK}	Data Hold Time from Falling Edge of SCLK	40	–	–	ns	
F _{SCLK}	Frequency of SCLK	0	–	8	MHz	
T _{ERASEB}	Flash Erase Time (Block)	–	10	–	ms	
T _{WRITE}	Flash Block Write Time	–	30	–	ms	
T _{DSCLK}	Data Out Delay from Falling Edge of SCLK	–	–	45	ns	V _{dd} > 3.6
T _{DSCLK3}	Data Out Delay from Falling Edge of SCLK	–	–	50	ns	3.0 ≤ V _{dd} ≤ 3.6

9.4.10 AC I²C Specifications

The following table lists guaranteed maximum and minimum specifications for the voltage and temperature ranges: 4.75V to 5.25V and $-40^{\circ}\text{C} \leq T_A \leq 85^{\circ}\text{C}$, or 3.0V to 3.6V and $-40^{\circ}\text{C} \leq T_A \leq 85^{\circ}\text{C}$, respectively. Typical parameters apply to 5V and 3.3V at 25°C and are for design guidance only.

Table 9-27. AC Characteristics of the I²C SDA and SCL Pins for Vdd

Symbol	Description	Standard Mode		Fast Mode		Units	Notes
		Min	Max	Min	Max		
F _{SCL I2C}	SCL Clock Frequency	0	100	0	400	kHz	
T _{HDSTAI2C}	Hold Time (repeated) START Condition. After this period, the first clock pulse is generated.	4.0	–	0.6	–	μs	
T _{LOWI2C}	LOW Period of the SCL Clock	4.7	–	1.3	–	μs	
T _{HIGHI2C}	HIGH Period of the SCL Clock	4.0	–	0.6	–	μs	
T _{SUSTA I2C}	Setup Time for a Repeated START Condition	4.7	–	0.6	–	μs	
T _{HDDAT I2C}	Data Hold Time	0	–	0	–	μs	
T _{SUDAT I2C}	Data Setup Time	250	–	100 ^[14]	–	ns	
T _{SUSTO I2C}	Setup Time for STOP Condition	4.0	–	0.6	–	μs	
T _{BUFI2C}	Bus Free Time Between a STOP and START Condition	4.7	–	1.3	–	μs	
T _{SPI2C}	Pulse Width of spikes are suppressed by the input filter.	–	–	0	50	ns	

Figure 9-6. Definition for Timing for Fast/Standard Mode on the I²C Bus

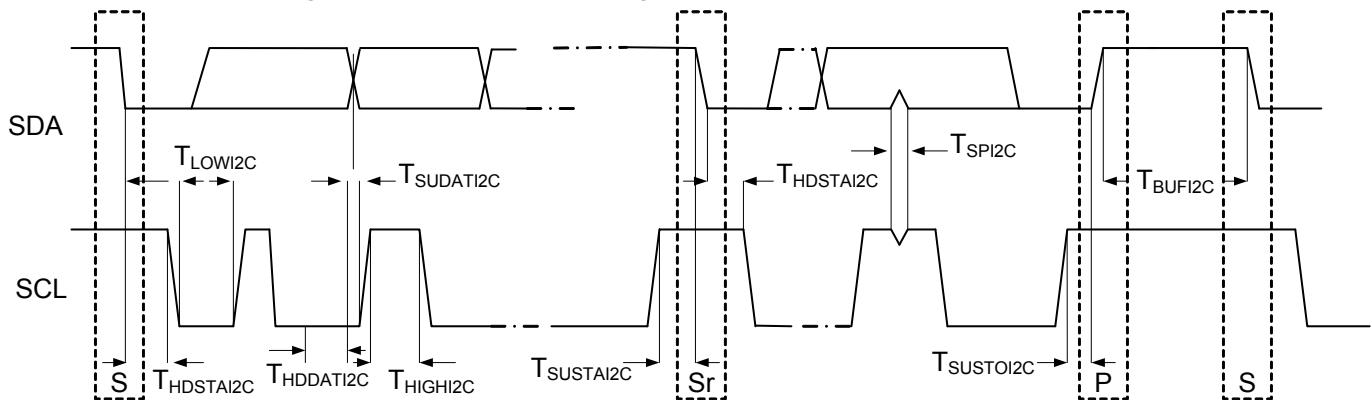

Note

14. A Fast-Mode I²C-bus device can be used in a Standard-Mode I²C-bus system, but the requirement $t_{SU,DAT} \lesssim 250$ ns must then be met. This automatically is the case if the device does not stretch the LOW period of the SCL signal. If such device does stretch the LOW period of the SCL signal, it must output the next data bit to the SDA line $t_{rmax} + t_{SU,DAT} = 1000 + 250 = 1250$ ns (according to the Standard-Mode I²C-bus specification) before the SCL line is released.

10. Packaging Dimensions

This section illustrates the package specification for the CY8C24x94 PSoC devices, along with the thermal impedance for the package and solder reflow peak temperatures.

Important Note Emulation tools may require a larger area on the target PCB than the chip's footprint. For a detailed description of the emulation tools' dimensions, refer to the document titled *PSoC Emulator Pod Dimensions* at <http://www.cypress.com/design/MR10161>.

Figure 10-1. 56-Pin (8x8 mm) QFN

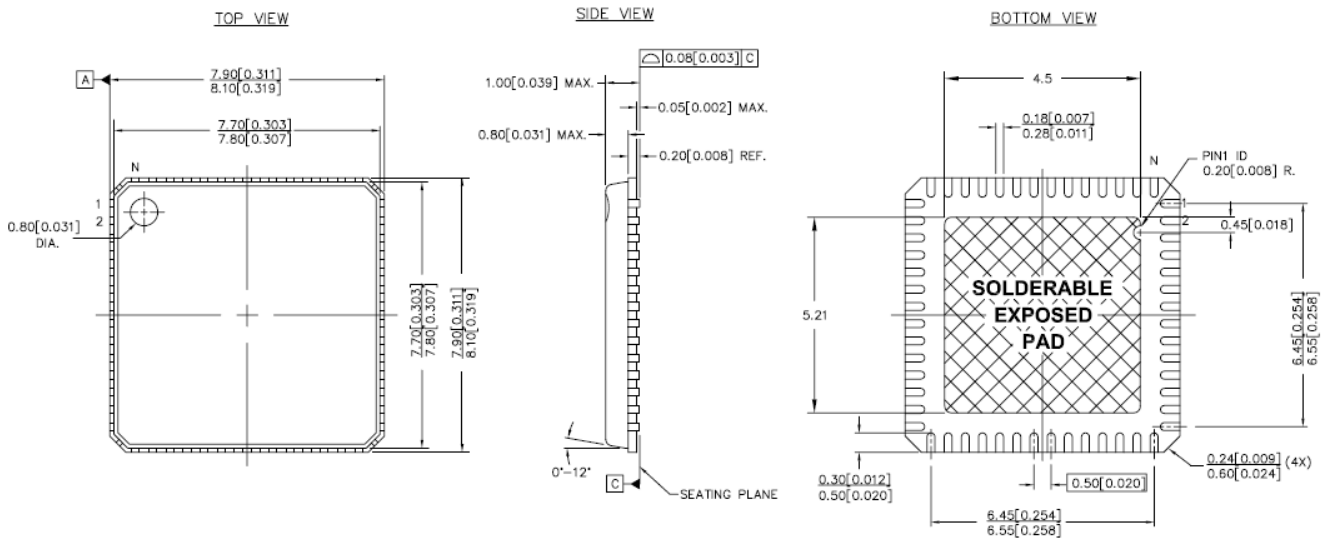

NOTES:

1.  HATCH AREA IS SOLDERABLE EXPOSED METAL.
2. REFERENCE JEDEC#: MO-220
3. PACKAGE WEIGHT: 0.162g
4. ALL DIMENSIONS ARE IN MM [MIN/MAX]
5. PACKAGE CODE

PART #	DESCRIPTION
LF56A	STANDARD
LY56A	PB-FREE

001-12921 **

Figure 10-2. 56-Pin QFN (8 X 8 X 0.9 MM) - Sawn

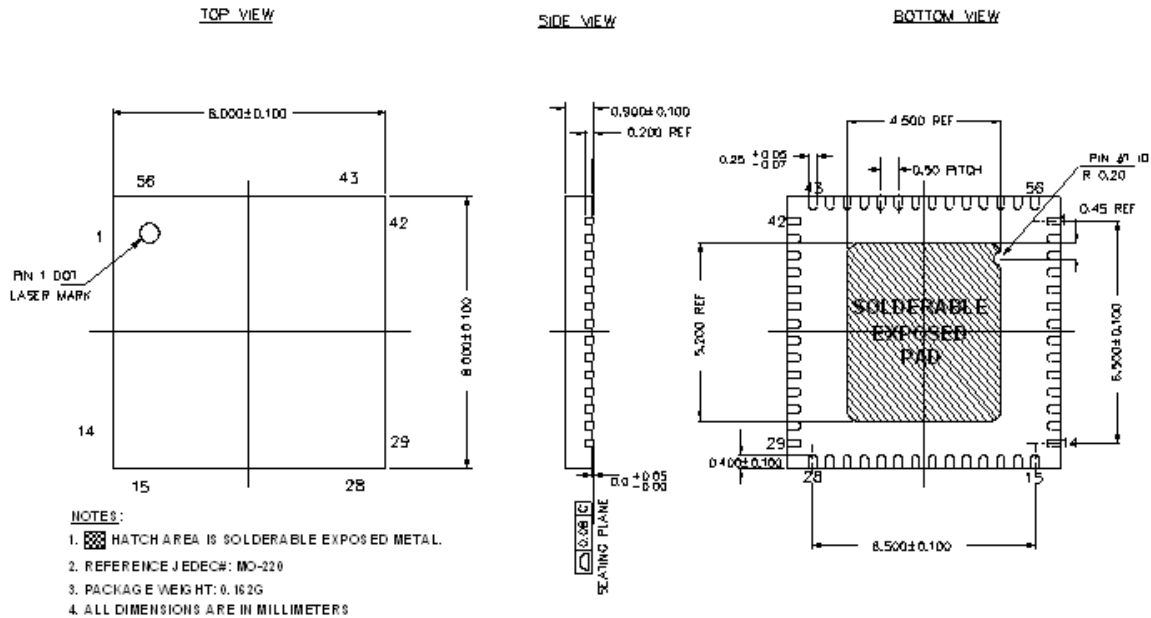

001-53450 **

Figure 10-3. 68-Pin (8x8 mm x 0.89 mm) QFN

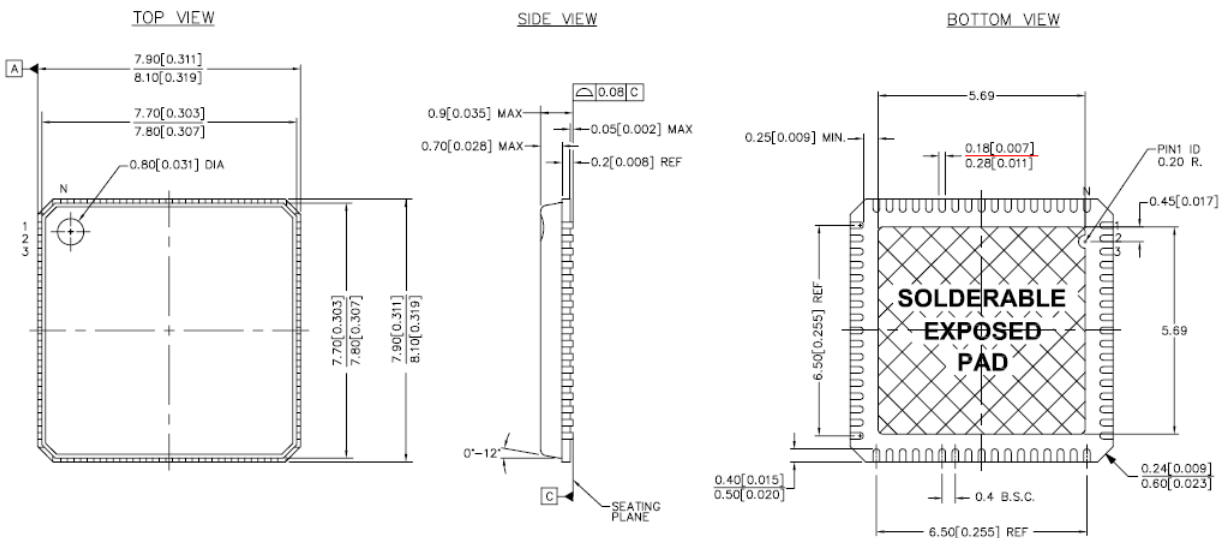

NOTES:

1.  HATCH IS SOLDERABLE EXPOSED PAD.
2. REFERENCE JEDEC#: MO-220
3. PACKAGE WEIGHT: 0.17g
4. ALL DIMENSIONS ARE IN MM [MIN/MAX]
5. PACKAGE CODE

PART #	DESCRIPTION
LF68	STANDARD
LY68	PB-FREE

NOTE: EXPOSED PAD DIMENSION VARIES BY LEADFRAME CAVITY (PADDLE) SIZE

51-85214 *C

Important Note

- For information on the preferred dimensions for mounting QFN packages, see the following Application Note at http://www.amkor.com/products/notes_papers/MLFAppNote.pdf.
- Pinned vias for thermal conduction are not required for the low-power PSoC device.

Figure 10-4. 68-Pin SAWN QFN (8X8 mm X 0.90 mm)

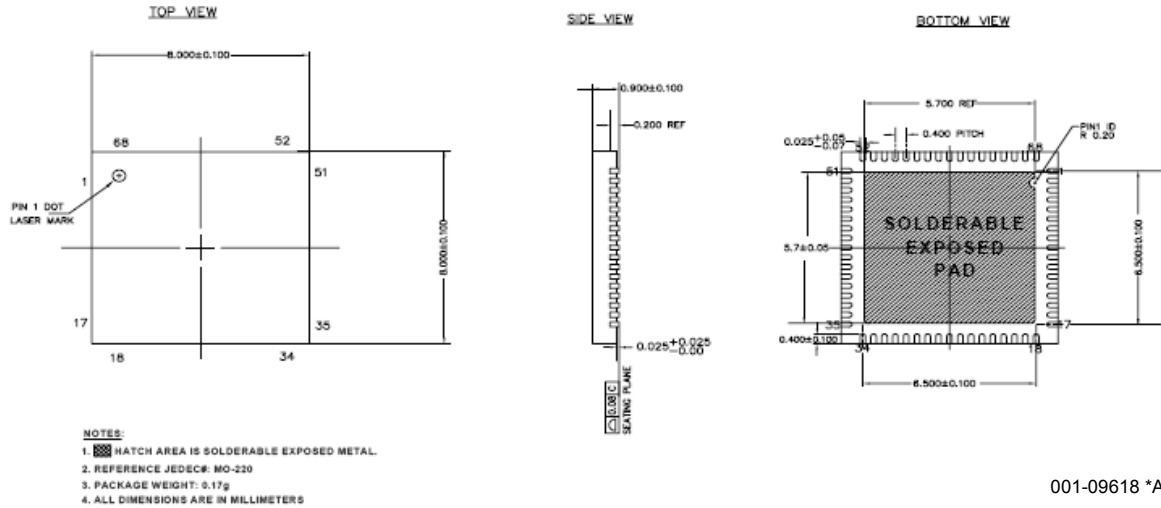

Figure 10-5. 100-Ball (6x6 mm) VFBGA

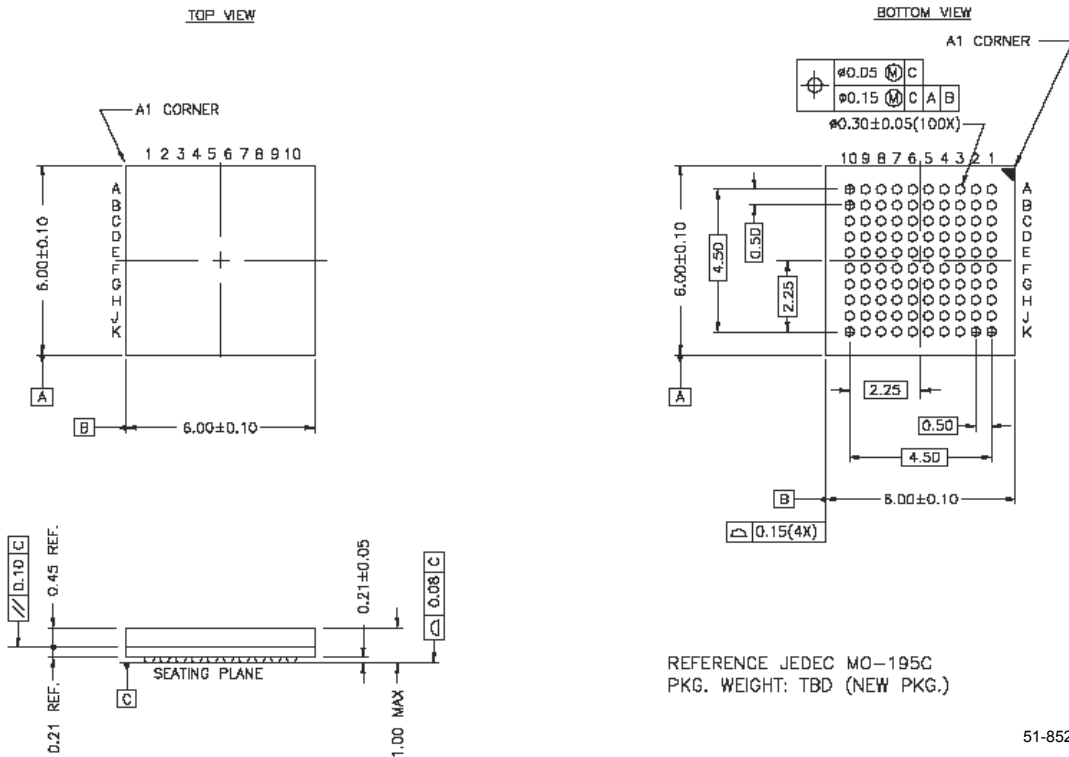
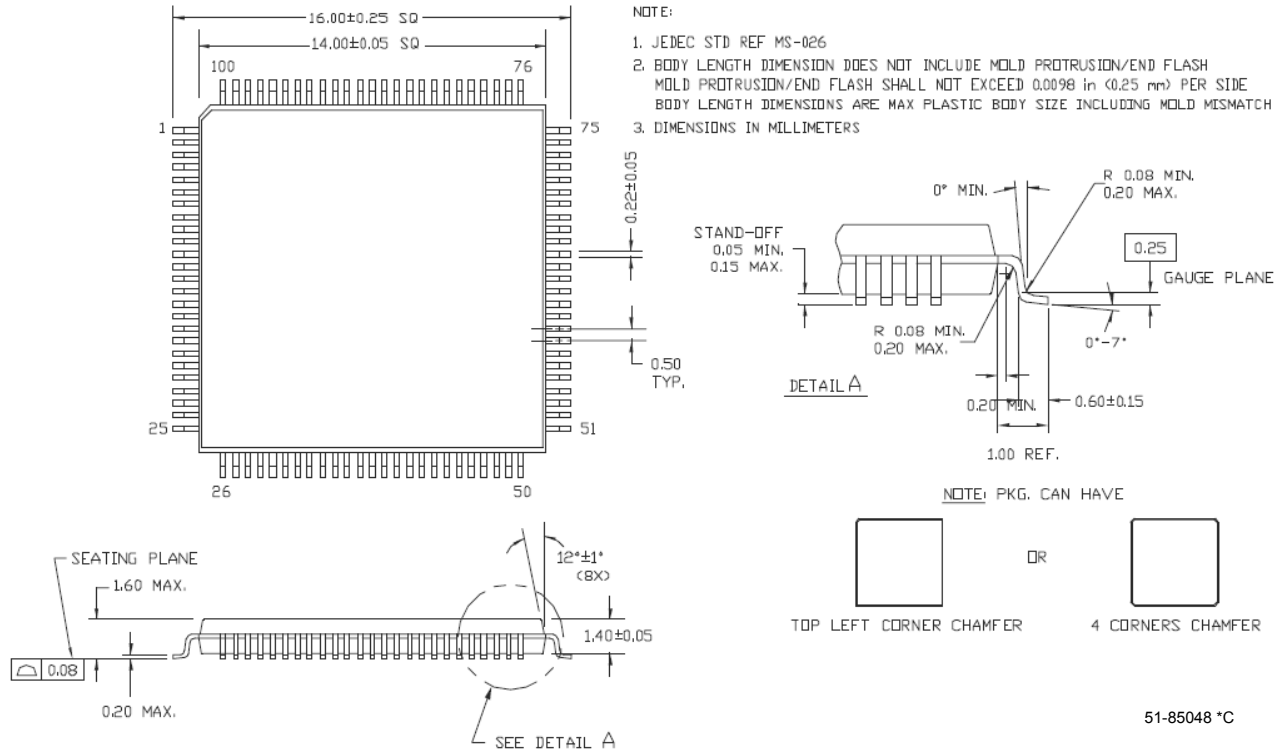

Figure 10-6. 100-Pin (14x14 x 1.4 mm) TQFP



10.1 Thermal Impedance

Table 10-1. Thermal Impedance for the Package

Package	Typical θ_{JA} [15]
56 QFN ^[16]	12.93 °C/W
68 QFN ^[16]	13.05 °C/W
100 VFBGA	65 °C/W
100 TQFP	51 °C/W

10.2 Solder Reflow Peak Temperature

Following is the minimum solder reflow peak temperature to achieve good solderability.

Table 10-2. Solder Reflow Peak Temperature

Package	Minimum Peak Temperature ^[17]	Maximum Peak Temperature
56 QFN	240°C	260°C
68 QFN	240°C	260°C
100 VFBGA	240°C	260°C

Notes

15. $T_J = T_A + \text{POWER} \times \theta_{JA}$

16. To achieve the thermal impedance specified for the QFN package, the center thermal pad should be soldered to the PCB ground plane.

17. Higher temperatures may be required based on the solder melting point. Typical temperatures for solder are $220 \pm 5^\circ\text{C}$ with Sn-Pb or $245 \pm 5^\circ\text{C}$ with Sn-Ag-Cu paste. Refer to the solder manufacturer specifications

11. Development Tool Selection

11.1 Software

11.1.1 PSoC Designer™

At the core of the PSoC development software suite is PSoC Designer, used to generate PSoC firmware applications. PSoC Designer is available free of charge at <http://www.cypress.com/psocdesigner> and includes a free C compiler.

11.1.2 PSoC Programmer

Flexible enough to be used on the bench in development, yet suitable for factory programming, PSoC Programmer works either as a standalone programming application or it can operate directly from PSoC Designer. PSoC Programmer software is compatible with both PSoC ICE-Cube In-Circuit Emulator and PSoC MiniProg. PSoC programmer is available free of charge at <http://www.cypress.com/psocprogrammer>.

11.2 Development Kits

All development kits can be purchased from the Cypress Online Store.

11.2.1 CY3215-DK Basic Development Kit

The CY3215-DK is for prototyping and development with PSoC Designer. This kit supports in-circuit emulation and the software interface enables users to run, halt, and single step the processor and view the content of specific memory locations. Advance emulation features also supported through PSoC Designer. The kit includes:

- PSoC Designer Software CD
- ICE-Cube In-Circuit Emulator
- ICE Flex-Pod for CY8C29x66 Family
- Cat-5 Adapter
- Mini-Eval Programming Board
- 110 ~ 240V Power Supply, Euro-Plug Adapter
- iMAGEcraft C Compiler (Registration Required)
- ISSP Cable
- USB 2.0 Cable and Blue Cat-5 Cable
- 2 CY8C29466-24PXI 28-PDIP Chip Samples

11.3 Evaluation Tools

All evaluation tools can be purchased from the Cypress Online Store.

11.3.1 CY3210-MiniProg1

The CY3210-MiniProg1 kit enables a user to program PSoC devices via the MiniProg1 programming unit. The MiniProg is a small, compact prototyping programmer that connects to the PC via a provided USB 2.0 cable. The kit includes:

- MiniProg Programming Unit
- MiniEval Socket Programming and Evaluation Board
- 28-Pin CY8C29466-24PXI PDIP PSoC Device Sample
- 28-Pin CY8C27443-24PXI PDIP PSoC Device Sample
- PSoC Designer Software CD
- Getting Started Guide
- USB 2.0 Cable

11.3.2 CY3210-PSoCEval1

The CY3210-PSoCEval1 kit features an evaluation board and the MiniProg1 programming unit. The evaluation board includes an LCD module, potentiometer, LEDs, and plenty of bread-boarding space to meet all of your evaluation needs. The kit includes:

- Evaluation Board with LCD Module
- MiniProg Programming Unit
- 28-Pin CY8C29466-24PXI PDIP PSoC Device Sample (2)
- PSoC Designer Software CD
- Getting Started Guide
- USB 2.0 Cable

11.3.3 CY3214-PSoCEvalUSB

The CY3214-PSoCEvalUSB evaluation kit features a development board for the CY8C24794-24LFXI PSoC device. Special features of the board include both USB and capacitive sensing development and debugging support. This evaluation board also includes an LCD module, potentiometer, LEDs, an enunciator and plenty of bread boarding space to meet all of your evaluation needs. The kit includes:

- PSoCEvalUSB Board
- LCD Module
- MiniProg Programming Unit
- Mini USB Cable
- PSoC Designer and Example Projects CD
- Getting Started Guide
- Wire Pack

11.4 Device Programmers

All device programmers can be purchased from the Cypress Online Store.

11.4.1 CY3216 Modular Programmer

The CY3216 Modular Programmer kit features a modular programmer and the MiniProg1 programming unit. The modular programmer includes three programming module cards and supports multiple Cypress products. The kit includes:

- Modular Programmer Base
- 3 Programming Module Cards
- MiniProg Programming Unit
- PSoC Designer Software CD
- Getting Started Guide
- USB 2.0 Cable

11.5 Accessories (Emulation and Programming)

Table 11-1. Emulation and Programming Accessories

Part #	Pin Package	Flex-Pod Kit ^[18]	Foot Kit ^[19]	Adapter ^[20]
CY8C24794-24LFXI	56 QFN	CY3250-24X94QFN	CY3250-56QFN-FK	AS-56-28
CY8C24894-24LFXI	56 QFN	CY3250-24X94QFN	CY3250-56QFN-FK	AS-28-28-02SS-6ENG-GANG

11.5.1 3rd-Party Tools

Several tools have been specially designed by the following 3rd-party vendors to accompany PSoC devices during development and production. Specific details for each of these tools are found at <http://www.cypress.com> under Design Resources > Evaluation Boards.

11.4.2 CY3207ISSP In-System Serial Programmer (ISSP)

The CY3207ISSP is a production programmer. It includes protection circuitry and an industrial case that is more robust than the MiniProg in a production-programming environment.

Note: CY3207ISSP needs special software and is not compatible with PSoC Programmer. The kit includes:

- CY3207 Programmer Unit
- PSoC ISSP Software CD
- 110 ~ 240V Power Supply, Euro-Plug Adapter
- USB 2.0 Cable

11.5.2 Build a PSoC Emulator into Your Board

For details on how to emulate your circuit before going to volume production using an on-chip debug (OCD) non-production PSoC device, see Application Note "Debugging - Build a PSoC Emulator into Your Board - AN2323" at <http://www.cypress.com/an2323>.

Notes

18. Flex-Pod kit includes a practice flex-pod and a practice PCB, in addition to two flex-pods.

19. Foot kit includes surface mount feet that are soldered to the target PCB.

20. Programming adapter converts non-DIP package to DIP footprint. Specific details and ordering information for each of the adapters are found at <http://www.emulation.com>.

12. Ordering Information

Table 12-1. CY8C24x94 PSoC Device's Key Features and Ordering Information

Package	Ordering Code	Flash (Bytes)	SRAM (Bytes)	Temperature Range	Digital Blocks	Analog Blocks	Digital I/O Pins	Analog Inputs	Analog Outputs	XRES Pin
56-Pin (8x8 mm) QFN (Sawn)	CY8C24794-24LTXI	16K	1K	-40°C to +85°C	4	6	50	48	2	No
56-Pin (8x8 mm) QFN (Sawn) (Tape and Reel)	CY8C24794-24LTXIT	16K	1K	-40°C to +85°C	4	6	50	48	2	No
56-Pin (8x8 mm) QFN	CY8C24894-24LTXI	16K	1K	-40°C to +85°C	4	6	50	48	2	No
56-Pin (8x8 mm) QFN	CY8C24894-24LTXIT	16K	1K	-40°C to +85°C	4	6	50	48	2	No
56-Pin (8x8 mm) QFN	CY8C24794-24LFXI	16K	1K	-40°C to +85°C	4	6	50	48	2	No
56-Pin (8x8 mm) QFN (Tape and Reel)	CY8C24794-24LFXIT	16K	1K	-40°C to +85°C	4	6	50	48	2	No
56-Pin (8x8 mm) QFN	CY8C24894-24LFXI	16K	1K	-40°C to +85°C	4	6	49	47	2	Yes
56-Pin (8x8 mm) QFN (Tape and Reel)	CY8C24894-24LFXIT	16K	1K	-40°C to +85°C	4	6	49	47	2	Yes
68 Pin OCD (8x8 mm) QFN ^[21]	CY8C24094-24LFXI	16K	1K	-40°C to +85°C	4	6	56	48	2	Yes
68 Pin (8x8 mm) QFN	CY8C24994-24LFXI	16K	1K	-40°C to +85°C	4	6	56	48	2	Yes
68 Pin (8x8 mm) QFN (Tape and Reel)	CY8C24994-24LFXIT	16K	1K	-40°C to +85°C	4	6	56	48	2	Yes
68-Pin QFN (Sawn)	CY8C24994-24LTXI	16K	1K	-40°C to +85°C	4	6	56	48	2	Yes
68-Pin QFN (Sawn)	CY8C24994-24LTXIT	16K	1K	-40°C to +85°C	4	6	56	48	2	Yes
100-Ball OCD (6x6 mm) VFBGA ^[21]	CY8C24094-24BVXI	16K	1K	-40°C to +85°C	4	6	56	48	2	Yes
100-Ball (6x6 mm) VFBGA	CY8C24994-24BVXI	16K	1K	-40°C to +85°C	4	6	56	48	2	Yes
100 Pin OCD TQFP ^[21]	CY8C24094-24AXI	16K	1K	-40°C to +85°C	4	6	56	48	2	Yes
68-Pin QFN (Sawn)	CY8C24094-24LTXI	16K	1K	-40°C to +85°C	4	6	56	48	2	Yes
68-Pin QFN (Sawn)	CY8C24094-24LTXIT	16K	1K	-40°C to +85°C	4	6	56	48	2	Yes

Note For Die sales information, contact a local Cypress sales office or Field Applications Engineer (FAE).

12.1 Ordering Code Definitions

CY 8 C 24 XXX-SP XX

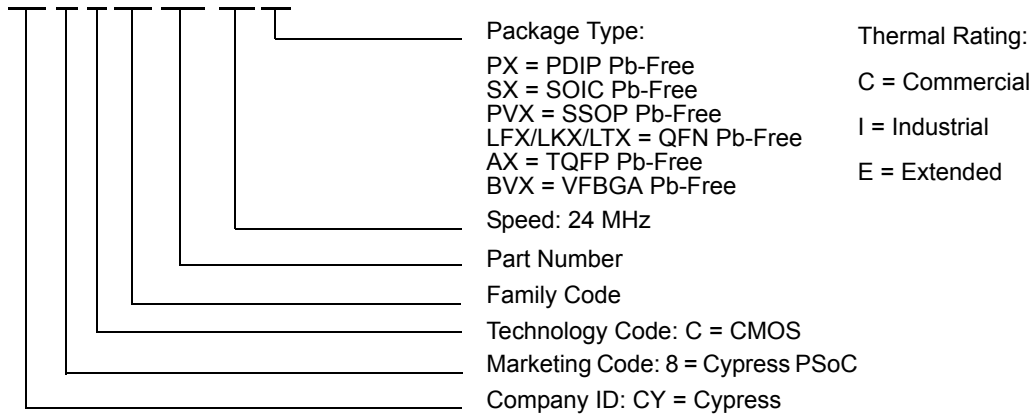

Note

21. This part may be used for in-circuit debugging. It is NOT available for production.

13. Document History Page

Document Title: CY8C24094, CY8C24794, CY8C24894 and CY8C24994 PSoC® Programmable System-on-Chip™ Document Number: 38-12018				
Rev.	ECN No.	Submission Date	Orig. of Change	Description of Change
**	133189	01.27.2004	NWJ	New silicon and new document – Advance Data Sheet.
*A	251672	See ECN	SFV	First Preliminary Data Sheet. Changed title to encompass only the CY8C24794 because the CY8C24494 and CY8C24694 are not being offered by Cypress.
*B	289742	See ECN	HMT	Add standard DS items from SFV memo. Add Analog Input Mux on pinouts. 2 MACs. Change 512 bytes of SRAM to 1K. Add dimension key to package. Remove HAPI. Update diagrams, registers and specs.
*C	335236	See ECN	HMT	Add CY logo. Update CY copyright. Update new CY.com URLs. Re-add ISSP programming pinout notation. Add Reflow Temp. table. Update features (MAC, Oscillator, and voltage range), registers (INT_CLR2/MSK2, second MAC), and specs. (Rext, IMO, analog output buffer...).
*D	344318	See ECN	HMT	Add new color and logo. Expand analog arch. diagram. Fix I/O#. Update Electrical Specifications.
*E	346774	See ECN	HMT	Add USB temperature specifications. Make data sheet Final.
*F	349566	See ECN	HMT	Remove USB logo. Add URL to preferred dimensions for mounting MLF packages.
*G	393164	See ECN	HMT	Add new device, CY8C24894 56-pin MLF with XRES pin. Add Fimousb3v char. to specs. Upgrade to CY Perform logo and update corporate address and copyright.
*H	469243	See ECN	HMT	Add ISSP note to pinout tables. Update typical and recommended Storage Temperature per industrial specs. Update Low Output Level maximum I/OL budget. Add FLS_PR1 to Register Map Bank 1 for users to specify which Flash bank should be used for SRAM operations. Add two new devices for a 68-pin QFN and 100-ball VFBGA under RPNs: CY8C24094 and CY8C24994. Add two packages for 68-pin QFN. Add OCD non-production pinouts and package diagrams. Update CY branding and QFN convention. Add new Dev. Tool section. Update copyright and trademarks.
*I	561158	See ECN	HMT	Add Low Power Comparator (LPC) AC/DC electrical spec. tables. Add CY8C20x34 to PSoC Device Characteristics table. Add detailed dimensions to 56-pin QFN package diagram and update revision. Secure one package diagram/manufacturing per QFN. Update emulation pod/feet kit part numbers. Fix pinout type-o per TestTrack.
*J	728238	See ECN	HMT	Add CapSense SNR requirement reference. Update figure standards. Update Technical Training paragraphs. Add QFN package clarifications and dimensions. Update ECN-ed Amkor dimensioned QFN package diagram revisions. Reword SNR reference. Add new 56-pin QFN spec.
*K	2552459	08/14/08	AZIE/PYRS	Add footnote on AGND descriptions to avoid using P2[4] for digital signaling as it may add noise to AGND. Remove reference to CMP_GO_EN1 in Map Bank 1 Table on Address 65; this register has no functionality on 24xxx. Add footnote on die sales. Add description 'Optional External Clock Input' on P1[4] to match description of P1[4].
*L	2616550	12/05/08	OGNE/PYRS	Updated Programmable Pin Configuration detail. Changed title from PSoC® Mixed-Signal Array to PSoC® Programmable System-on-Chip™
*M	2657956	02/11/09	DPT/PYRS	Added package diagram 001-09618 and updated Ordering Information table
*N	2708135	05/18/2009	BRW	Added Note in the Pin Information section on page 8. Removed reference to Hi-Tech Lite Compiler in the section Development Tools Selection on page 42.
*O	2718162	06/11/2009	DPT	Added 56-Pin QFN (Sawn) package diagram and updated ordering information

Sales, Solutions, and Legal Information

Worldwide Sales and Design Support

Cypress maintains a worldwide network of offices, solution centers, manufacturer's representatives, and distributors. To find the office closest to you, visit us at cypress.com/sales.

Products

PSoC	psoc.cypress.com
Clocks & Buffers	clocks.cypress.com
Wireless	wireless.cypress.com
Memories	memory.cypress.com
Image Sensors	image.cypress.com

PSoC Solutions

General	psoc.cypress.com/solutions
Low Power/Low Voltage	psoc.cypress.com/low-power
Precision Analog	psoc.cypress.com/precision-analog
LCD Drive	psoc.cypress.com/lcd-drive
CAN 2.0b	psoc.cypress.com/can
USB	psoc.cypress.com/usb

© Cypress Semiconductor Corporation, 2004-2009. The information contained herein is subject to change without notice. Cypress Semiconductor Corporation assumes no responsibility for the use of any circuitry other than circuitry embodied in a Cypress product. Nor does it convey or imply any license under patent or other rights. Cypress products are not warranted nor intended to be used for medical, life support, life saving, critical control or safety applications, unless pursuant to an express written agreement with Cypress. Furthermore, Cypress does not authorize its products for use as critical components in life-support systems where a malfunction or failure may reasonably be expected to result in significant injury to the user. The inclusion of Cypress products in life-support systems application implies that the manufacturer assumes all risk of such use and in doing so indemnifies Cypress against all charges.

Any Source Code (software and/or firmware) is owned by Cypress Semiconductor Corporation (Cypress) and is protected by and subject to worldwide patent protection (United States and foreign), United States copyright laws and international treaty provisions. Cypress hereby grants to licensee a personal, non-exclusive, non-transferable license to copy, use, modify, create derivative works of, and compile the Cypress Source Code and derivative works for the sole purpose of creating custom software and or firmware in support of licensee product to be used only in conjunction with a Cypress integrated circuit as specified in the applicable agreement. Any reproduction, modification, translation, compilation, or representation of this Source Code except as specified above is prohibited without the express written permission of Cypress.

Disclaimer: CYPRESS MAKES NO WARRANTY OF ANY KIND, EXPRESS OR IMPLIED, WITH REGARD TO THIS MATERIAL, INCLUDING, BUT NOT LIMITED TO, THE IMPLIED WARRANTIES OF MERCHANTABILITY AND FITNESS FOR A PARTICULAR PURPOSE. Cypress reserves the right to make changes without further notice to the materials described herein. Cypress does not assume any liability arising out of the application or use of any product or circuit described herein. Cypress does not authorize its products for use as critical components in life-support systems where a malfunction or failure may reasonably be expected to result in significant injury to the user. The inclusion of Cypress' product in a life-support systems application implies that the manufacturer assumes all risk of such use and in doing so indemnifies Cypress against all charges.

Use may be limited by and subject to the applicable Cypress software license agreement.

Looking for pricing, stock, or lifecycle information?

Click below to explore more details on WIN SOURCE:

 [View CY8C24894-24LFXI on WIN SOURCE](#)

 [Infineon Technologies](#) Information

Optimize Your Supply Chain with WIN SOURCE Solutions

-  Global Sourcing Solution
-  Obsolete Management
-  Cost Control Management
-  Shortage Management
-  Alternative Solution
-  Excess Inventory Management