



**THE DATASHEET OF
CY8C24423A-24PVXIT**



Features

- Powerful Harvard-architecture processor
 - M8C processor speeds up to 24 MHz
 - 8 × 8 multiply, 32-bit accumulate
 - Low power at high speed
 - Operating voltage: 2.4 V to 5.25 V
 - Operating voltages down to 1.0 V using on-chip switch mode pump (SMP)
 - Industrial temperature range: -40 °C to +85 °C
- Advanced peripherals (PSoC® blocks)
 - Six rail-to-rail analog PSoC blocks provide:
 - Up to 14-bit analog-to-digital converters (ADCs)
 - Up to 9-bit digital-to-analog converters (DACs)
 - Programmable gain amplifiers (PGAs)
 - Programmable filters and comparators
 - Four digital PSoC blocks provide:
 - 8- to 32-bit timers and counters, 8- and 16-bit pulse-width modulators (PWMs)
 - Cyclical redundancy check (CRC) and pseudo random sequence (PRS) modules
 - Full-duplex universal asynchronous receiver transmitter (UART)
 - Multiple serial peripheral interface (SPI) masters or slaves
 - Can connect to all general-purpose I/O (GPIO) pins
 - Complex peripherals by combining blocks
- Precision, programmable clocking
 - Internal ±5% 24- / 48-MHz main oscillator
 - High accuracy 24 MHz with optional 32 kHz crystal and phase-locked loop (PLL)
 - Optional external oscillator up to 24 MHz
 - Internal oscillator for watchdog and sleep
- Flexible on-chip memory
 - 4 KB flash program storage 50,000 erase/write cycles
 - 256-bytes SRAM data storage
 - In-system serial programming (ISSP)
 - Partial flash updates
 - Flexible protection modes
 - Electronically erasable programmable read only memory (EEPROM) emulation in flash
- Programmable pin configurations
 - 25-mA sink, 10-mA source on all GPIOs
 - Pull-up, pull-down, high Z, strong, or open-drain drive modes on all GPIOs
 - Eight standard analog inputs on all GPIOs, and four additional analog inputs with restricted routing
 - Two 30 mA analog outputs on all GPIOs
 - Configurable interrupt on all GPIOs
- New CY8C24x23A PSoC device
 - Derived from the CY8C24x23 device
 - Low power and low voltage (2.4 V)
- Additional system resources
 - I²C slave, master, and multi-master to 400 kHz
 - Watchdog and sleep timers
 - User-configurable low-voltage detection (LVD)
 - Integrated supervisory circuit
 - On-chip precision voltage reference
- Complete development tools
 - Free development software (PSoC Designer™)
 - Full-featured, in-circuit emulator (ICE), and programmer
 - Full-speed emulation
 - Complex breakpoint structure
 - 128 KB trace memory

Logic Block Diagram

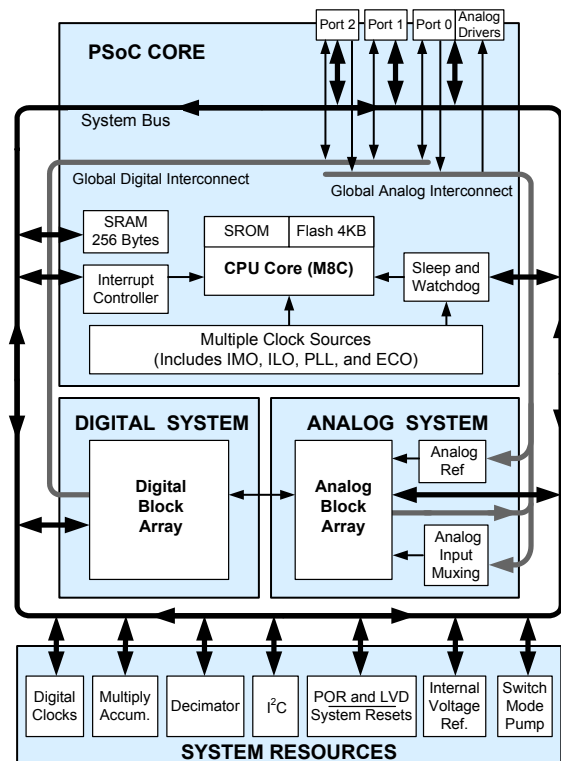

Errata: For information on silicon errata, see "Errata" on page 67. Details include trigger conditions, devices affected, and proposed workaround.

More Information

Cypress provides a wealth of data at www.cypress.com to help you to select the right PSoC device for your design, and to help you to quickly and effectively integrate the device into your design. Following is an abbreviated list for PSoC 1:

- Overview: [PSoC Portfolio](#), [PSoC Roadmap](#)
- Product Selectors: [PSoC 1](#), [PSoC 3](#), [PSoC 4](#), or [PSoC 5LP](#)
 In addition, [PSoC Designer](#) offers a device selection tool within PSoC 1, at the time of creating a new project.
- Datasheets: Describe and provide electrical specifications for all the PSoC 1 family of devices. Visit the [PSoC 1 datasheets](#) web page for a complete list
- Application notes and code examples:
 - Visit the [PSoC 1 Code Examples](#) web page for a comprehensive list of code examples
 - Cypress offers a large number of PSoC application notes covering a broad range of topics, from basic to advanced level. Recommended application notes for getting started with PSoC 1 are:
 - [AN75320](#): Getting Started with PSoC® 1
 - [AN2094](#): PSoC® 1 - Getting Started with GPIO
 - [AN2015](#): PSoC® 1 - Getting Started with Flash & E2PROM
 - [AN2014](#): Basics of PSoC® 1 Programming
 - [AN32200](#): PSoC® 1 - Clocks and Global Resources
 - [AN2010](#): PSoC® 1 Best Practices and Recommendations
- Technical Reference Manual (TRM):
 - Visit the [PSoC 1 TRM](#) page for the complete list of TRMs. Following documents provide detailed descriptions of the Architecture, Programming specification and Register map details of CY8C2XXXX PSoC 1 device family.
 - [PSoC1 CY8C2XXXX TRM](#)
 - [PSoC1 ISSP Programming Specifications](#)
 - Development Kits:
 - [CY3210 - CY8C24x23 PSoC\(R\) Evaluation Pods \(EvalPod\)](#) are 28-pin PDIP adapters that seamlessly connect any PSoC device to the 28-pin PDIP connector on any Cypress PSoC development kit. CY3210-24x23 provides evaluation of the CY8C24x23A PSoC device family on any PSoC developer kit. PSoC developer kits are sold separately.
 - Visit the [PSoC® 1 Kits](#) page and refer the [Kit Selector Guide](#) document to find out the suitable development kits and debuggers for all PSoC 1 families.
 - The [CY3217-MiniProg1](#) and [CY8CKIT-002 PSoC® MiniProg3](#) device provide an interface for flash programming.
 - [Knowledge Base Articles \(KBA\)](#): Provide design and application tips from experts on the devices/kits. For example, [Flash read/write access from firmware](#), explains how we can read and write to flash in PSoC 1 devices

PSoC Designer

[PSoC Designer](#) is a free Windows-based Integrated Design Environment (IDE). It enables concurrent hardware and firmware design of systems based on CapSense (see [Figure 1](#)). With PSoC Designer, you can:

1. Drag and drop user modules to build your hardware system design in the main design workspace
2. Codesign your application firmware with the PSoC hardware, using the PSoC Designer IDE C compiler
3. Configure user module
4. Explore the library of user modules
5. Review user module datasheets

Figure 1. PSoC Designer Features

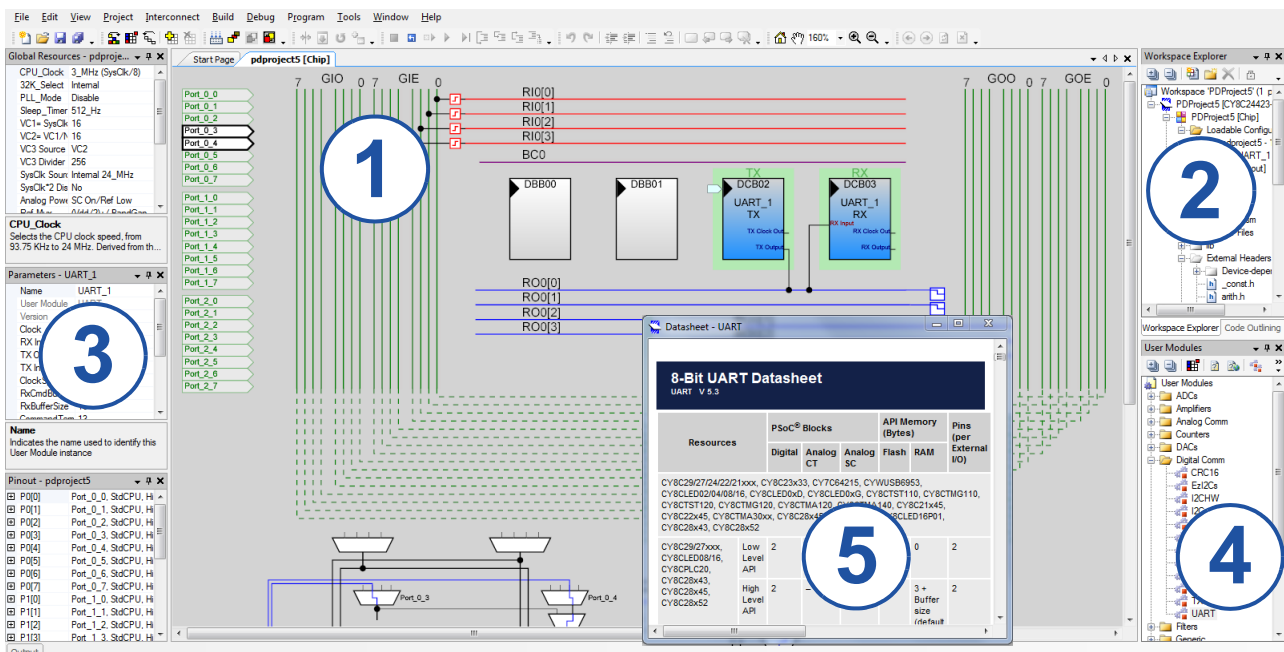



Contents

PSoC Functional Overview	4	AC Electrical Characteristics	37
PSoC Core	4	Packaging Information	51
Digital System	4	Packaging Dimensions	51
Analog System	5	Thermal Impedances	57
Additional System Resources	6	Capacitance on Crystal Pins	57
PSoC Device Characteristics	6	Solder Reflow Specifications	57
Getting Started	7	Development Tool Selection	58
Application Notes	7	Software	58
Development Kits	7	Development Kits	58
Training	7	Evaluation Tools	58
CYPros Consultants	7	Device Programmers	59
Solutions Library	7	Accessories (Emulation and Programming)	59
Technical Support	7	Ordering Information	60
Development Tools	8	Ordering Code Definitions	60
PSoC Designer Software Subsystems	8	Acronyms	61
Designing with PSoC Designer	9	Acronyms Used	61
Select User Modules	9	Reference Documents	61
Configure User Modules	9	Document Conventions	62
Organize and Connect	9	Units of Measure	62
Generate, Verify, and Debug	9	Numeric Conventions	62
Pinouts	10	Glossary	62
8-Pin Part Pinout	10	Errata	67
20-Pin Part Pinout	11	Part Numbers Affected	67
28-Pin Part Pinout	12	CY8C24123A Qualification Status	67
32-Pin Part Pinout	13	CY8C24123A Errata Summary	67
56-Pin Part Pinout	14	Document History Page	68
Register Reference	15	Sales, Solutions, and Legal Information	71
Register Conventions	15	Worldwide Sales and Design Support	71
Register Mapping Tables	15	Products	71
Electrical Specifications	18	PSoC® Solutions	71
Absolute Maximum Ratings	18	Cypress Developer Community	71
Operating Temperature	19	Technical Support	71
DC Electrical Characteristics	19		



PSoC Functional Overview

The PSoC family consists of many programmable system-on-chips with on-chip controller devices. These devices are designed to replace multiple traditional MCU-based system components with a low-cost single-chip programmable device. PSoC devices include configurable blocks of analog and digital logic, and programmable interconnects. This architecture makes it possible for you to create customized peripheral configurations that match the requirements of each individual application. Additionally, a fast CPU, flash program memory, SRAM data memory, and configurable I/O are included in a range of convenient pinouts and packages.

The PSoC architecture, shown in Figure 2, consists of four main areas: PSoC core, digital system, analog system, and system resources. Configurable global busing allows combining all the device resources into a complete custom system. The PSoC CY8C24x23A family can have up to three I/O ports that connect to the global digital and analog interconnects, providing access to four digital blocks and six analog blocks.

PSoC Core

The PSoC core is a powerful engine that supports a rich feature set. The core includes a CPU, memory, clocks, and configurable GPIOs.

The M8C CPU core is a powerful processor with speeds up to 24 Hz, providing a four-MIPS 8-bit Harvard-architecture microprocessor. The CPU uses an interrupt controller with 11 vectors, to simplify programming of real time embedded events. Program execution is timed and protected using the included sleep and watchdog timers (WDT).

Memory encompasses 4 KB of flash for program storage, 256 bytes of SRAM for data storage, and up to 2 KB of EEPROM emulated using the flash. Program flash uses four protection levels on blocks of 64 bytes, allowing customized software IP protection.

The PSoC device incorporates flexible internal clock generators, including a 24 MHz internal main oscillator (IMO) accurate to $\pm 2.5\%$ to $\pm 5\%$ over temperature and voltage^[1]. The 24 MHz IMO can also be doubled to 48 MHz for use by the digital system. A low power 32 kHz internal low speed oscillator (ILO) is provided for the sleep timer and WDT. If crystal accuracy is required, the ECO (32.768 kHz external crystal oscillator) is available for use as a real time clock (RTC) and can optionally generate a crystal-accurate 24 MHz system clock using a PLL. The clocks, together with programmable clock dividers (as a System Resource), provide the flexibility to integrate almost any timing requirement into the PSoC device.

PSoC GPIOs provide connection to the CPU, digital, and analog resources of the device. Each pin's drive mode may be selected from eight options, allowing great flexibility in external interfacing. Every pin can generate a system interrupt on high level, low level, and change from last read.

Digital System

The digital system consists of four digital PSoC blocks. Each block is an 8-bit resource that may be used alone or combined with other blocks to form 8-, 16-, 24-, and 32-bit peripherals, which are called user module references.

Figure 2. Digital System Block Diagram

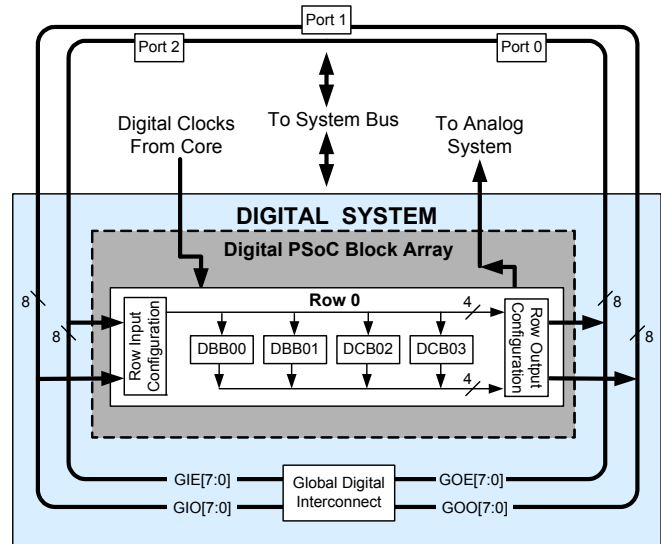

Digital peripheral configurations are:

- PWMs (8- and 16-bit)
- PWMs with dead band (8- and 16-bit)
- Counters (8- to 32-bit)
- Timers (8- to 32-bit)
- UART 8-bit with selectable parity
- SPI master and slave
- I²C slave and multi-master (one is available as a system resource)
- CRC generator (8- to 32-bit)
- IrDA
- PRS generators (8- to 32-bit)

The digital blocks may be connected to any GPIO through a series of global buses that can route any signal to any pin. The buses also allow for signal multiplexing and performing logic operations. This configurability frees your designs from the constraints of a fixed peripheral controller.

Digital blocks are provided in rows of four, where the number of blocks varies by PSoC device family. This gives a choice of system resources for your application. Family resources are shown in Table 1 on page 6.

Note

1. **Errata:** When the device is operated within 0 °C to 70 °C, the frequency tolerance is reduced to $\pm 2.5\%$, but if operated at extreme temperature (below 0 °C or above 70 °C), frequency tolerance deviates from $\pm 2.5\%$ to $\pm 5\%$. For more information, see "Errata" on page 67.



Analog System

The analog system consists of six configurable blocks, each consisting of an opamp circuit that allows the creation of complex analog signal flows. Analog peripherals are very flexible and can be customized to support specific application requirements. Some of the more common PSoC analog functions (most available as user modules) are:

- ADCs (up to two, with 6- to 14-bit resolution, selectable as incremental, delta sigma, and SAR)
- Filters (two and four pole band-pass, low-pass, and notch)
- Amplifiers (up to two, with selectable gain to 48x)
- Instrumentation amplifiers (one with selectable gain to 93x)
- Comparators (up to two, with 16 selectable thresholds)
- DACs (up to two, with 6 to 9-bit resolution)
- Multiplying DACs (up to two, with 6 to 9-bit resolution)
- High current output drivers (two with 30 mA drive as a PSoC Core resource)
- 1.3 V reference (as a system resource)
- DTMF dialer
- Modulators
- Correlators
- Peak detectors
- Many other topologies possible

Analog blocks are arranged in a column of three, which includes one continuous time (CT) and two switched capacitor (SC) blocks, as shown in [Figure 3](#)

Figure 3. Analog System Block Diagram

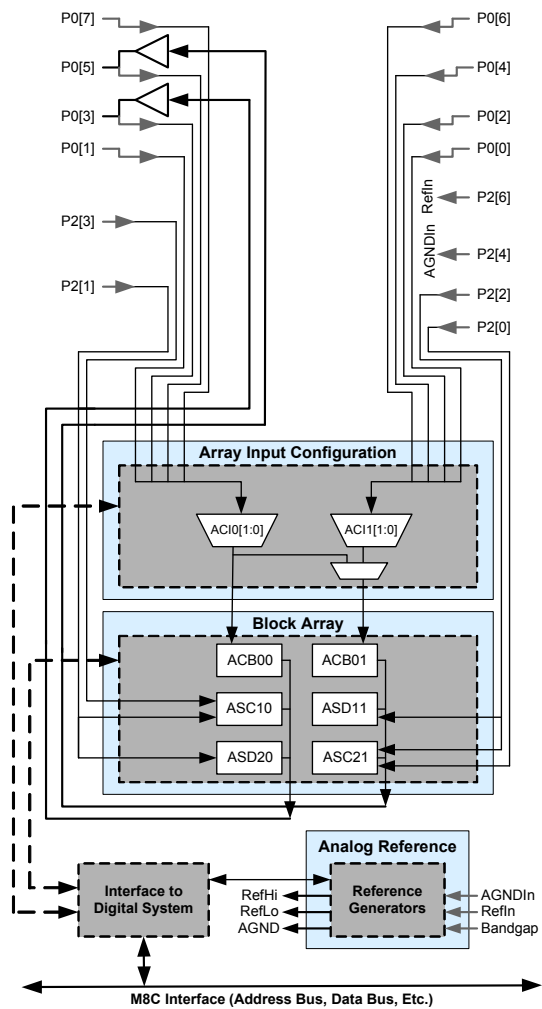

Additional System Resources

System resources, some of which are listed in the previous sections, provide additional capability useful to complete systems. Additional resources include a multiplier, decimator, switch-mode pump, low-voltage detection, and power-on-reset (POR). Statements describing the merits of each system resource follow:

- Digital clock dividers provide three customizable clock frequencies for use in applications. The clocks can be routed to both the digital and analog systems. Additional clocks may be generated using digital PSoC blocks as clock dividers.
- A multiply accumulate (MAC) provides a fast 8-bit multiplier with 32-bit accumulate, to assist in both general math and digital filters.
- The decimator provides a custom hardware filter for digital signal processing applications including the creation of Delta Sigma ADCs.
- The I²C module provides 100- and 400-kHz communication over two wires. slave, master, and multi-master are supported.
- Low-voltage detection (LVD) interrupts can signal the application of falling voltage levels, while the advanced POR circuit eliminates the need for a system supervisor.
- An internal 1.3 V reference provides an absolute reference for the analog system, including ADCs and DACs.
- An integrated switch-mode pump generates normal operating voltages from a single 1.2 V battery cell, providing a low cost boost converter.

PSoC Device Characteristics

Depending on your PSoC device characteristics, the digital and analog systems can have 16, 8, or 4 digital blocks, and 12, 6, or 4 analog blocks. Table 1 lists the resources available for specific PSoC device groups. The PSoC device covered by this datasheet is highlighted in this table.

Table 1. PSoC Device Characteristics

PSoC Part Number	Digital I/O	Digital Rows	Digital Blocks	Analog Inputs	Analog Outputs	Analog Columns	Analog Blocks	SRAM Size	Flash Size
CY8C29x66	up to 64	4	16	up to 12	4	4	12	2 K	32 K
CY8C28xxx	up to 44	up to 3	up to 12	up to 44	up to 4	up to 6	up to 12 + 4 ^[2]	1 K	16 K
CY8C27x43	up to 44	2	8	up to 12	4	4	12	256	16 K
CY8C24x94	up to 56	1	4	up to 48	2	2	6	1 K	16 K
CY8C24x23A	up to 24	1	4	up to 12	2	2	6	256	4 K
CY8C23x33	up to 26	1	4	up to 12	2	2	4	256	8 K
CY8C22x45	up to 38	2	8	up to 38	0	4	6 ^[2]	1 K	16 K
CY8C21x45	up to 24	1	4	up to 24	0	4	6 ^[2]	512	8 K
CY8C21x34	up to 28	1	4	up to 28	0	2	4 ^[2]	512	8 K
CY8C21x23	up to 16	1	4	up to 8	0	2	4 ^[2]	256	4 K
CY8C20x34	up to 28	0	0	up to 28	0	0	3 ^[2,3]	512	8 K
CY8C20xx6	up to 36	0	0	up to 36	0	0	3 ^[2,3]	up to 2 K	up to 32 K

Notes

2. Limited analog functionality.
3. Two analog blocks and one CapSense®.

Getting Started

For in depth information, along with detailed programming details, see the PSoC® [Technical Reference Manual](#).

For up-to-date ordering, packaging, and electrical specification information, see the latest [PSoC device datasheets](#) on the web.

Application Notes

[Cypress application notes](#) are an excellent introduction to the wide variety of possible PSoC designs.

Development Kits

[PSoC Development Kits](#) are available online from and through a growing number of regional and global distributors, which include Arrow, Avnet, Digi-Key, Farnell, Future Electronics, and Newark.

Training

[Free PSoC technical training](#) (on demand, webinars, and workshops), which is available online via www.cypress.com,

covers a wide variety of topics and skill levels to assist you in your designs.

CYPros Consultants

Certified PSoC Consultants offer everything from technical assistance to completed PSoC designs. To contact or become a PSoC Consultant go to the [CYPros Consultants](#) web site.

Solutions Library

Visit our growing [library of solution focused designs](#). Here you can find various application designs that include firmware and hardware design files that enable you to complete your designs quickly.

Technical Support

[Technical support](#) – including a searchable knowledge base articles and technical forums – is also available online. If you cannot find an answer to your question, call our Technical Support hotline at 1-800-541-4736.

Development Tools

PSoC Designer™ is the revolutionary integrated design environment (IDE) that you can use to customize PSoC to meet your specific application requirements. PSoC Designer software accelerates system design and time to market. Develop your applications using a library of precharacterized analog and digital peripherals (called user modules) in a drag-and-drop design environment. Then, customize your design by leveraging the dynamically generated application programming interface (API) libraries of code. Finally, debug and test your designs with the integrated debug environment, including in-circuit emulation and standard software debug features. PSoC Designer includes:

- Application editor graphical user interface (GUI) for device and user module configuration and dynamic reconfiguration
- Extensive user module catalog
- Integrated source-code editor (C and assembly)
- Free C compiler with no size restrictions or time limits
- Built-in debugger
- In-circuit emulation
- Built-in support for communication interfaces:
 - Hardware and software I²C slaves and masters
 - Full-speed USB 2.0
 - Up to four full-duplex universal asynchronous receiver/transmitters (UARTs), SPI master and slave, and wireless

PSoC Designer supports the entire library of PSoC 1 devices and runs on Windows XP, Windows Vista, and Windows 7.

PSoC Designer Software Subsystems

Design Entry

In the chip-level view, choose a base device to work with. Then select different onboard analog and digital components that use the PSoC blocks, which are called user modules. Examples of user modules are analog-to-digital converters (ADCs), digital-to-analog converters (DACs), amplifiers, and filters. Configure the user modules for your chosen application and connect them to each other and to the proper pins. Then generate your project. This prepopulates your project with APIs and libraries that you can use to program your application.

The tool also supports easy development of multiple configurations and dynamic reconfiguration. Dynamic reconfiguration makes it possible to change configurations at run time. In essence, this lets you to use more than 100 percent of PSoC's resources for an application.

Code Generation Tools

The code generation tools work seamlessly within the PSoC Designer interface and have been tested with a full range of debugging tools. You can develop your design in C, assembly, or a combination of the two.

Assemblers. The assemblers allow you to merge assembly code seamlessly with C code. Link libraries automatically use absolute addressing or are compiled in relative mode, and linked with other software modules to get absolute addressing.

C Language Compilers. C language compilers are available that support the PSoC family of devices. The products allow you to create complete C programs for the PSoC family devices. The optimizing C compilers provide all of the features of C, tailored to the PSoC architecture. They come complete with embedded libraries providing port and bus operations, standard keypad and display support, and extended math functionality.

Debugger

PSoC Designer has a debug environment that provides hardware in-circuit emulation, allowing you to test the program in a physical system while providing an internal view of the PSoC device. Debugger commands allow you to read and program and read and write data memory, and read and write I/O registers. You can read and write CPU registers, set and clear breakpoints, and provide program run, halt, and step control. The debugger also lets you to create a trace buffer of registers and memory locations of interest.

Online Help System

The online help system displays online, context-sensitive help. Designed for procedural and quick reference, each functional subsystem has its own context-sensitive help. This system also provides tutorials and links to FAQs and an Online Support Forum to aid the designer.

In-Circuit Emulator

A low-cost, high-functionality in-circuit emulator (ICE) is available for development support. This hardware can program single devices.

The emulator consists of a base unit that connects to the PC using a USB port. The base unit is universal and operates with all PSoC devices. Emulation pods for each device family are available separately. The emulation pod takes the place of the PSoC device in the target board and performs full-speed (24 MHz) operation.

Designing with PSoC Designer

The development process for the PSoC device differs from that of a traditional fixed-function microprocessor. The configurable analog and digital hardware blocks give the PSoC architecture a unique flexibility that pays dividends in managing specification change during development and lowering inventory costs. These configurable resources, called PSoC blocks, have the ability to implement a wide variety of user-selectable functions. The PSoC development process is:

1. Select [user modules](#).
2. Configure user modules.
3. Organize and connect.
4. Generate, verify, and debug.

Select User Modules

PSoC Designer provides a library of prebuilt, pretested hardware peripheral components called “user modules.” User modules make selecting and implementing peripheral devices, both analog and digital, simple.

Configure User Modules

Each user module that you select establishes the basic register settings that implement the selected function. They also provide parameters and properties that allow you to tailor their precise configuration to your particular application. For example, a PWM User Module configures one or more digital PSoC blocks, one for each eight bits of resolution. Using these parameters, you can establish the pulse width and duty cycle. Configure the parameters and properties to correspond to your chosen application. Enter values directly or by selecting values from drop-down menus. All of the user modules are documented in datasheets that may be viewed directly in PSoC Designer or on the Cypress website. These [user module datasheets](#) explain the internal operation of the user module and provide performance specifications. Each datasheet describes the use of each user

module parameter, and other information that you may need to successfully implement your design.

Organize and Connect

Build signal chains at the chip level by interconnecting user modules to each other and the I/O pins. Perform the selection, configuration, and routing so that you have complete control over all on-chip resources.

Generate, Verify, and Debug

When you are ready to test the hardware configuration or move on to developing code for the project, perform the “Generate Configuration Files” step. This causes PSoC Designer to generate source code that automatically configures the device to your specification and provides the software for the system. The generated code provides APIs with high-level functions to control and respond to hardware events at run time, and interrupt service routines that you can adapt as needed.

A complete code development environment lets you to develop and customize your applications in C, assembly language, or both.

The last step in the development process takes place inside PSoC Designer’s Debugger (accessed by clicking the Connect icon). PSoC Designer downloads the HEX image to the ICE where it runs at full-speed. PSoC Designer debugging capabilities rival those of systems costing many times more. In addition to traditional single-step, run-to-breakpoint, and watch-variable features, the debug interface provides a large trace buffer. It lets you to define complex breakpoint events that include monitoring address and data bus values, memory locations, and external signals.

Pinouts

This section describes, lists, and illustrates the CY8C24x23A PSoC device pins and pinout configurations. Every port pin (labeled with a “P”) is capable of digital I/O. However, V_{SS}, V_{DD}, SMP, and XRES are not capable of digital I/O.

8-Pin Part Pinout

Table 2. 8-Pin PDIP and SOIC

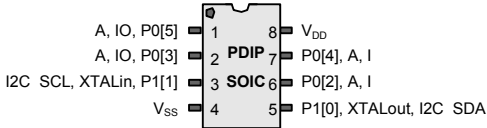
Pin No.	Type		Pin Name	Description	
	Digital	Analog			
1	I/O	I/O	P0[5]	Analog column mux input and column output	Figure 4. CY8C24123A 8-Pin PSoC Device 
2	I/O	I/O	P0[3]	Analog column mux input and column output	
3	I/O		P1[1]	Crystal input (XTALin), I ² C serial clock (SCL), ISSP-SCLK ^[4]	
4	Power		V _{SS}	Ground connection	
5	I/O		P1[0]	Crystal output (XTALout), I ² C serial data (SDA), ISSP-SDATA ^[4]	
6	I/O	I	P0[2]	Analog column mux input	
7	I/O	I	P0[4]	Analog column mux input	
8	Power		V _{DD}	Supply voltage	

LEGEND: A = Analog, I = Input, and O = Output.

Note

4. These are the ISSP pins, which are not high Z at POR. See the [PSoC Technical Reference Manual](#) for details.

20-Pin Part Pinout

Table 3. 20-Pin PDIP, SSOP, and SOIC

Pin No.	Type		Pin Name	Description
	Digital	Analog		
1	I/O	I	P0[7]	Analog column mux input
2	I/O	I/O	P0[5]	Analog column mux input and column output
3	I/O	I/O	P0[3]	Analog column mux input and column output
4	I/O	I	P0[1]	Analog column mux input
5	Power		SMP	SMP connection to external components required
6	I/O		P1[7]	I ² C SCL
7	I/O		P1[5]	I ² C SDA
8	I/O		P1[3]	
9	I/O		P1[1]	XTALin, I ² C SCL, ISSP-SCLK ^[5]
10	Power		V _{SS}	Ground connection.
11	I/O		P1[0]	XTALout, I ² C SDA, ISSP-SDATA ^[5]
12	I/O		P1[2]	
13	I/O		P1[4]	Optional external clock input (EXTCLK)
14	I/O		P1[6]	
15	Input		XRES	Active high external reset with internal pull-down
16	I/O	I	P0[0]	Analog column mux input
17	I/O	I	P0[2]	Analog column mux input
18	I/O	I	P0[4]	Analog column mux input
19	I/O	I	P0[6]	Analog column mux input
20	Power		V _{DD}	Supply voltage

Figure 5. CY8C24223A 20-Pin PSoC Device

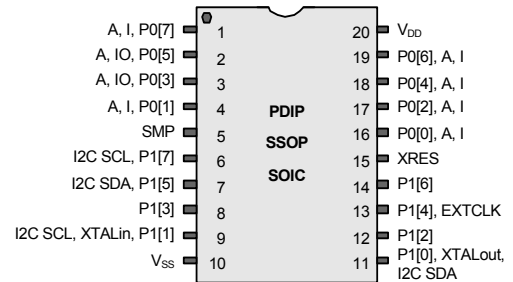

LEGEND: A = Analog, I = Input, and O = Output.

Note

5. These are the ISSP pins, which are not high Z at POR. See the [PSoC Technical Reference Manual](#) for details.

28-Pin Part Pinout

Table 4. 28-Pin PDIP, SSOP, and SOIC

Pin No.	Type		Pin Name	Description
	Digital	Analog		
1	I/O	I	P0[7]	Analog column mux input
2	I/O	I/O	P0[5]	Analog column mux input and column output
3	I/O	I/O	P0[3]	Analog column mux input and column output
4	I/O	I	P0[1]	Analog column mux input
5	I/O		P2[7]	
6	I/O		P2[5]	
7	I/O	I	P2[3]	Direct switched capacitor block input
8	I/O	I	P2[1]	Direct switched capacitor block input
9	Power		SMP	SMP connection to external components required
10	I/O		P1[7]	I ² C SCL
11	I/O		P1[5]	I ² C SDA
12	I/O		P1[3]	
13	I/O		P1[1]	XTALin, I ² C SCL, ISSP-SCLK ^[6]
14	Power		V _{SS}	Ground connection.
15	I/O		P1[0]	XTALout, I ² C SDA, ISSP-SDATA ^[6]
16	I/O		P1[2]	
17	I/O		P1[4]	Optional EXTCLK
18	I/O		P1[6]	
19	Input		XRES	Active high external reset with internal pull-down
20	I/O	I	P2[0]	Direct switched capacitor block input
21	I/O	I	P2[2]	Direct switched capacitor block input
22	I/O		P2[4]	External analog ground (AGND)
23	I/O		P2[6]	External voltage reference (V _{REF})
24	I/O	I	P0[0]	Analog column mux input
25	I/O	I	P0[2]	Analog column mux input
26	I/O	I	P0[4]	Analog column mux input
27	I/O	I	P0[6]	Analog column mux input
28	Power		V _{DD}	Supply voltage

Figure 6. CY8C24423A 28-Pin PSoC Device

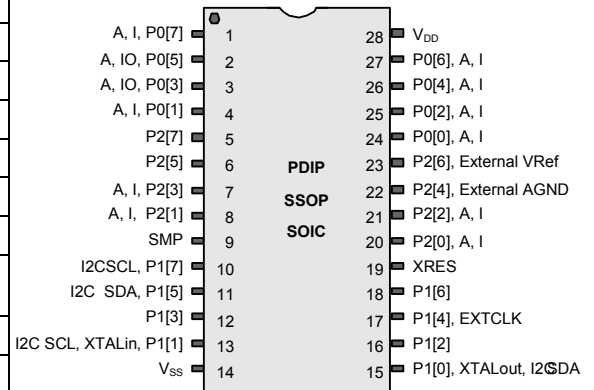

Not for Production

LEGEND: A = Analog, I = Input, and O = Output.

Note

6. These are the ISSP pins, which are not high Z at POR. See the [PSoC Technical Reference Manual](#) for details.



32-Pin Part Pinout

Table 5. 32-Pin QFN^[7]

Pin No.	Type		Pin Name	Description
	Digital	Analog		
1	I/O		P2[7]	
2	I/O		P2[5]	
3	I/O	I	P2[3]	Direct switched capacitor block input
4	I/O	I	P2[1]	Direct switched capacitor block input
5	Power		V _{SS}	Ground connection
6	Power		SMP	SMP connection to external components required
7	I/O		P1[7]	I ² C SCL
8	I/O		P1[5]	I ² C SDA
9			NC	No connection. Pin must be left floating
10	I/O		P1[3]	
11	I/O		P1[1]	XTALin, I ² C SCL, ISSP-SCLK ^[8]
12	Power		V _{SS}	Ground Connection
13	I/O		P1[0]	XTALout, I ² C SDA, ISSP-SDATA ^[8]
14	I/O		P1[2]	
15	I/O		P1[4]	Optional EXTCLK
16			NC	No connection. Pin must be left floating
17	I/O		P1[6]	
18	Input		XRES	Active high external reset with internal pull-down
19	I/O	I	P2[0]	Direct switched capacitor block input
20	I/O	I	P2[2]	Direct switched capacitor block input
21	I/O		P2[4]	External AGND
22	I/O		P2[6]	External V _{REF}
23	I/O	I	P0[0]	Analog column mux input
24	I/O	I	P0[2]	Analog column mux input
25			NC	No connection. Pin must be left floating
26	I/O	I	P0[4]	Analog column mux input
27	I/O	I	P0[6]	Analog column mux input
28	Power		V _{DD}	Supply voltage
29	I/O	I	P0[7]	Analog column mux input
30	I/O	I/O	P0[5]	Analog column mux input and column output
31	I/O	I/O	P0[3]	Analog column mux input and column output
32	I/O	I	P0[1]	Analog column mux input

LEGEND: A = Analog, I = Input, and O = Output.

Figure 7. CY8C24423A 32-Pin PSoC Device

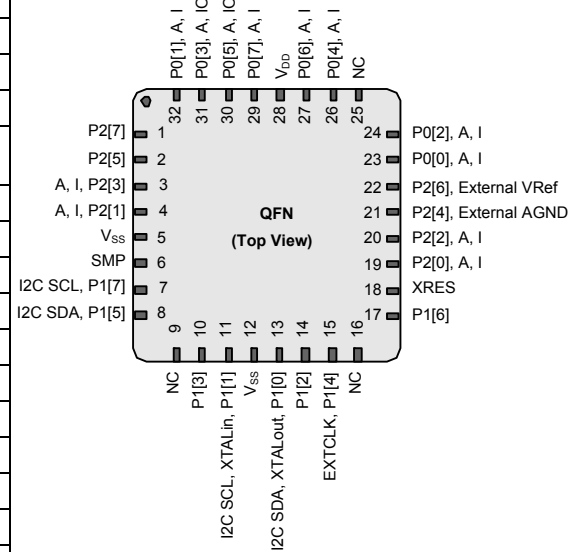

Notes

- The center pad on the QFN package must be connected to ground (V_{SS}) for best mechanical, thermal, and electrical performance. If not connected to ground, it must be electrically floated and not connected to any other signal.
- These are the ISSP pins, which are not high Z at POR. See the [PSoC Technical Reference Manual](#) for details.

56-Pin Part Pinout

The 56-pin SSOP part is for the CY8C24000A On-Chip Debug (OCD) PSoC device.

Note This part is only used for in-circuit debugging. It is NOT available for production.

Table 6. 56-Pin SSOP OCD

Pin No.	Type		Pin Name	Description
	Digital	Analog		
1			NC	No connection. Pin must be left floating
2	I/O	I	P0[7]	Analog column mux input
3	I/O	I	P0[5]	Analog column mux input and column output
4	I/O	I	P0[3]	Analog column mux input and column output
5	I/O	I	P0[1]	Analog column mux input
6	I/O		P2[7]	
7	I/O		P2[5]	
8	I/O	I	P2[3]	Direct switched capacitor block input
9	I/O	I	P2[1]	Direct switched capacitor block input
10			NC	No connection. Pin must be left floating
11			NC	No connection. Pin must be left floating
12			NC	No connection. Pin must be left floating
13			NC	No connection. Pin must be left floating
14	OCD		OCDE	OCD even data I/O
15	OCD		OCDO	OCD odd data output
16	Power		SMP	SMP connection to required external components
17			NC	No connection. Pin must be left floating
18			NC	No connection. Pin must be left floating
19			NC	No connection. Pin must be left floating
20			NC	No connection. Pin must be left floating
21			NC	No connection. Pin must be left floating
22			NC	No connection. Pin must be left floating
23	I/O		P1[7]	I ² C SCL
24	I/O		P1[5]	I ² C SDA
25			NC	No connection. Pin must be left floating
26	I/O		P1[3]	
27	I/O		P1[1]	XTALin, I ² C SCL, ISSP-SCLK ⁽⁹⁾
28	Power		V _{DD}	Supply voltage
29			NC	No connection. Pin must be left floating
30			NC	No connection. Pin must be left floating
31	I/O		P1[0]	XTALout, I ² C SDA, ISSP-SDATA ⁽⁹⁾
32	I/O		P1[2]	
33	I/O		P1[4]	Optional EXTCLK
34	I/O		P1[6]	
35			NC	No connection. Pin must be left floating
36			NC	No connection. Pin must be left floating
37			NC	No connection. Pin must be left floating
38			NC	No connection. Pin must be left floating
39			NC	No connection. Pin must be left floating
40			NC	No connection. Pin must be left floating
41	Input		XRES	Active high external reset with internal pull-down.
42	OCD		HCLK	OCD high speed clock output.
43	OCD		CCLK	OCD CPU clock output.
44			NC	No connection. Pin must be left floating
45			NC	No connection. Pin must be left floating
46			NC	No connection. Pin must be left floating
47			NC	No connection. Pin must be left floating
48	I/O	I	P2[0]	Direct switched capacitor block input.
49	I/O	I	P2[2]	Direct switched capacitor block input.
50	I/O		P2[4]	External AGND.
51	I/O		P2[6]	External V _{REF} .
52	I/O	I	P0[0]	Analog column mux input.
53	I/O	I	P0[2]	Analog column mux input and column output.
54	I/O	I	P0[4]	Analog column mux input and column output.
55	I/O	I	P0[6]	Analog column mux input.
56	Power		V _{DD}	Supply voltage.

LEGEND: A = Analog, I = Input, O = Output, and OCD = On-Chip Debug.

Figure 8. CY8C24000A 56-Pin PSoC Device

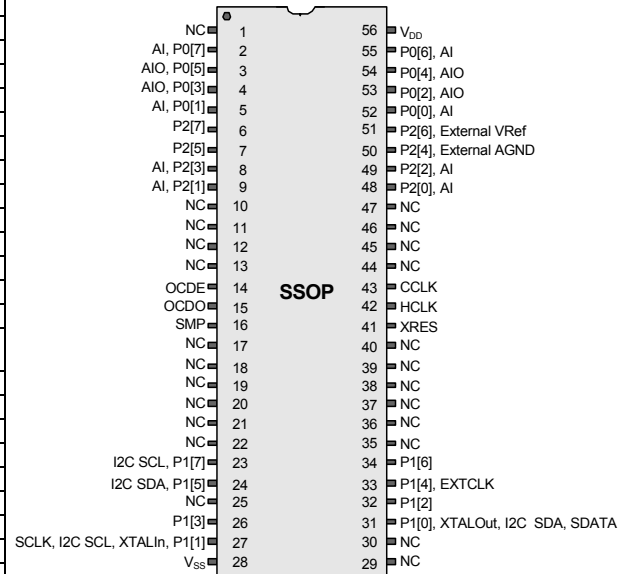

Note

9. These are the ISSP pins, which are not high Z at POR. See the PSoC Technical Reference Manual for details.

Register Reference

This section lists the registers of the CY8C24x23A PSoC device. For detailed register information, see the [PSoC Programmable System-on-Chip Reference Manual](#).

Register Conventions

Abbreviations Used

The register conventions specific to this section are listed in the following table.

Table 7. Abbreviations

Convention	Description
R	Read register or bit(s)
W	Write register or bit(s)
L	Logical register or bit(s)
C	Clearable register or bit(s)
#	Access is bit specific

Register Mapping Tables

The PSoC device has a total register address space of 512 bytes. The register space is referred to as I/O space and is divided into two banks, Bank 0 and Bank 1. The XOI bit in the Flag register (CPU_F) determines which bank the user is currently in. When the XOI bit is set, the user is in Bank 1.

Note In the following register mapping tables, blank fields are reserved and must not be accessed.



Table 8. Register Map Bank 0 Table: User Space

Name	Addr (0,Hex)	Access	Name	Addr (0,Hex)	Access	Name	Addr (0,Hex)	Access	Name	Addr (0,Hex)	Access
PRT0DR	00	RW		40		ASC10CR0	80	RW		C0	
PRT0IE	01	RW		41		ASC10CR1	81	RW		C1	
PRT0GS	02	RW		42		ASC10CR2	82	RW		C2	
PRT0DM2	03	RW		43		ASC10CR3	83	RW		C3	
PRT1DR	04	RW		44		ASD11CR0	84	RW		C4	
PRT1IE	05	RW		45		ASD11CR1	85	RW		C5	
PRT1GS	06	RW		46		ASD11CR2	86	RW		C6	
PRT1DM2	07	RW		47		ASD11CR3	87	RW		C7	
PRT2DR	08	RW		48			88			C8	
PRT2IE	09	RW		49			89			C9	
PRT2GS	0A	RW		4A			8A			CA	
PRT2DM2	0B	RW		4B			8B			CB	
	0C			4C			8C			CC	
	0D			4D			8D			CD	
	0E			4E			8E			CE	
	0F			4F			8F			CF	
	10			50		ASD20CR0	90	RW		D0	
	11			51		ASD20CR1	91	RW		D1	
	12			52		ASD20CR2	92	RW		D2	
	13			53		ASD20CR3	93	RW		D3	
	14			54		ASC21CR0	94	RW		D4	
	15			55		ASC21CR1	95	RW		D5	
	16			56		ASC21CR2	96	RW	I2C_CFG	D6	RW
	17			57		ASC21CR3	97	RW	I2C_SCR	D7	#
	18			58			98		I2C_DR	D8	RW
	19			59			99		I2C_MSCR	D9	#
	1A			5A			9A		INT_CLR0	DA	RW
	1B			5B			9B		INT_CLR1	DB	RW
	1C			5C			9C			DC	
	1D			5D			9D		INT_CLR3	DD	RW
	1E			5E			9E		INT_MSK3	DE	RW
	1F			5F			9F			DF	
DBB00DR0	20	#	AMX_IN	60	RW		A0		INT_MSK0	E0	RW
DBB00DR1	21	W		61			A1		INT_MSK1	E1	RW
DBB00DR2	22	RW		62			A2		INT_VC	E2	RC
DBB00CR0	23	#	ARF_CR	63	RW		A3		RES_WDT	E3	W
DBB01DR0	24	#	CMP_CR0	64	#		A4		DEC_DH	E4	RC
DBB01DR1	25	W	ASY_CR	65	#		A5		DEC_DL	E5	RC
DBB01DR2	26	RW	CMP_CR1	66	RW		A6		DEC_CR0	E6	RW
DBB01CR0	27	#		67			A7		DEC_CR1	E7	RW
DCB02DR0	28	#		68			A8		MUL_X	E8	W
DCB02DR1	29	W		69			A9		MUL_Y	E9	W
DCB02DR2	2A	RW		6A			AA		MUL_DH	EA	R
DCB02CR0	2B	#		6B			AB		MUL_DL	EB	R
DCB03DR0	2C	#		6C			AC		ACC_DR1	EC	RW
DCB03DR1	2D	W		6D			AD		ACC_DR0	ED	RW
DCB03DR2	2E	RW		6E			AE		ACC_DR3	EE	RW
DCB03CR0	2F	#		6F			AF		ACC_DR2	EF	RW
	30		ACB00CR3	70	RW	RDI0RI	B0	RW		F0	
	31		ACB00CR0	71	RW	RDI0SYN	B1	RW		F1	
	32		ACB00CR1	72	RW	RDI0IS	B2	RW		F2	
	33		ACB00CR2	73	RW	RDI0LT0	B3	RW		F3	
	34		ACB01CR3	74	RW	RDI0LT1	B4	RW		F4	
	35		ACB01CR0	75	RW	RDI0RO0	B5	RW		F5	
	36		ACB01CR1	76	RW	RDI0RO1	B6	RW		F6	
	37		ACB01CR2	77	RW		B7		CPU_F	F7	RL
	38			78			B8			F8	
	39			79			B9			F9	
	3A			7A			BA			FA	
	3B			7B			BB			FB	
	3C			7C			BC			FC	
	3D			7D			BD			FD	
	3E			7E			BE		CPU_SCR1	FE	#
	3F			7F			BF		CPU_SCR0	FF	#

Blank fields are Reserved and must not be accessed.

Access is bit specific.



Table 9. Register Map Bank 1 Table: Configuration Space

Name	Addr (1,Hex)	Access	Name	Addr (1,Hex)	Access	Name	Addr (1,Hex)	Access	Name	Addr (1,Hex)	Access
PRT0DM0	00	RW		40		ASC10CR0	80	RW		C0	
PRT0DM1	01	RW		41		ASC10CR1	81	RW		C1	
PRT0IC0	02	RW		42		ASC10CR2	82	RW		C2	
PRT0IC1	03	RW		43		ASC10CR3	83	RW		C3	
PRT1DM0	04	RW		44		ASD11CR0	84	RW		C4	
PRT1DM1	05	RW		45		ASD11CR1	85	RW		C5	
PRT1IC0	06	RW		46		ASD11CR2	86	RW		C6	
PRT1IC1	07	RW		47		ASD11CR3	87	RW		C7	
PRT2DM0	08	RW		48			88			C8	
PRT2DM1	09	RW		49			89			C9	
PRT2IC0	0A	RW		4A			8A			CA	
PRT2IC1	0B	RW		4B			8B			CB	
	0C			4C			8C			CC	
	0D			4D			8D			CD	
	0E			4E			8E			CE	
	0F			4F			8F			CF	
	10			50		ASD20CR0	90	RW	GDI_O_IN	D0	RW
	11			51		ASD20CR1	91	RW	GDI_E_IN	D1	RW
	12			52		ASD20CR2	92	RW	GDI_O_OU	D2	RW
	13			53		ASD20CR3	93	RW	GDI_E_OU	D3	RW
	14			54		ASC21CR0	94	RW		D4	
	15			55		ASC21CR1	95	RW		D5	
	16			56		ASC21CR2	96	RW		D6	
	17			57		ASC21CR3	97	RW		D7	
	18			58			98			D8	
	19			59			99			D9	
	1A			5A			9A			DA	
	1B			5B			9B			DB	
	1C			5C			9C			DC	
	1D			5D			9D		OSC_GO_EN	DD	RW
	1E			5E			9E		OSC_CR4	DE	RW
	1F			5F			9F		OSC_CR3	DF	RW
DBB00FN	20	RW	CLK_CR0	60	RW		A0		OSC_CR0	E0	RW
DBB00IN	21	RW	CLK_CR1	61	RW		A1		OSC_CR1	E1	RW
DBB00OU	22	RW	ABF_CR0	62	RW		A2		OSC_CR2	E2	RW
	23		AMD_CR0	63	RW		A3		VLT_CR	E3	RW
DBB01FN	24	RW		64			A4		VLT_CMP	E4	R
DBB01IN	25	RW		65			A5			E5	
DBB01OU	26	RW	AMD_CR1	66	RW		A6			E6	
	27		ALT_CR0	67	RW		A7			E7	
DCB02FN	28	RW		68			A8		IMO_TR	E8	W
DCB02IN	29	RW		69			A9		ILO_TR	E9	W
DCB02OU	2A	RW		6A			AA		BDG_TR	EA	RW
	2B			6B			AB		ECO_TR	EB	W
DCB03FN	2C	RW		6C			AC			EC	
DCB03IN	2D	RW		6D			AD			ED	
DCB03OU	2E	RW		6E			AE			EE	
	2F			6F			AF			EF	
	30		ACB00CR3	70	RW	RDI0RI	B0	RW		F0	
	31		ACB00CR0	71	RW	RDI0SYN	B1	RW		F1	
	32		ACB00CR1	72	RW	RDI0IS	B2	RW		F2	
	33		ACB00CR2	73	RW	RDI0LT0	B3	RW		F3	
	34		ACB01CR3	74	RW	RDI0LT1	B4	RW		F4	
	35		ACB01CR0	75	RW	RDI0RO0	B5	RW		F5	
	36		ACB01CR1	76	RW	RDI0RO1	B6	RW		F6	
	37		ACB01CR2	77	RW		B7		CPU_F	F7	RL
	38			78			B8			F8	
	39			79			B9			F9	
	3A			7A			BA			FA	
	3B			7B			BB			FB	
	3C			7C			BC			FC	
	3D			7D			BD			FD	
	3E			7E			BE		CPU_SCR1	FE	#
	3F			7F			BF		CPU_SCR0	FF	#

Blank fields are Reserved and must not be accessed.

Access is bit specific.

Electrical Specifications

This section presents the DC and AC electrical specifications of the CY8C24x23A PSoC device. For the latest electrical specifications, check if you have the most recent datasheet by visiting the website at <http://www.cypress.com>.

Specifications are valid for $-40\text{ }^{\circ}\text{C} \leq T_A \leq 85\text{ }^{\circ}\text{C}$ and $T_J \leq 100\text{ }^{\circ}\text{C}$, except where noted.

Refer to [Table 30 on page 37](#) for the electrical specifications for the IMO using SLIMO mode.

Figure 9. Voltage versus CPU Frequency

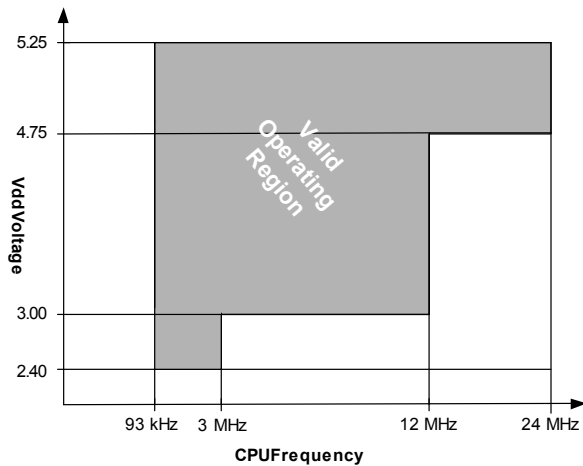
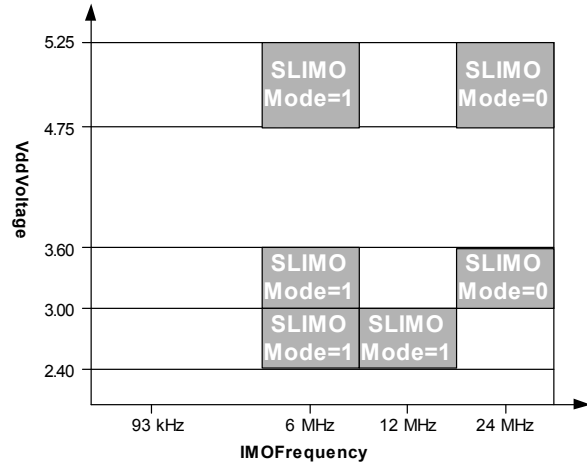

Figure 10. IMO Frequency Trim Options



Absolute Maximum Ratings

Exceeding maximum ratings may shorten the useful life of the device. User guidelines are not tested.

Table 10. Absolute Maximum Ratings

Symbol	Description	Min	Typ	Max	Units	Notes
T_{STG}	Storage temperature	-55	25	+100	$^{\circ}\text{C}$	Higher storage temperatures reduce data retention time. Recommended storage temperature is $+25\text{ }^{\circ}\text{C} \pm 25\text{ }^{\circ}\text{C}$. Extended duration storage temperatures above $65\text{ }^{\circ}\text{C}$ degrades reliability.
$T_{BAKETEMP}$	Bake temperature	-	125	See package label	$^{\circ}\text{C}$	
$t_{BAKETIME}$	Bake time	See package label	-	72	Hours	
T_A	Ambient temperature with power applied	-40	-	+85	$^{\circ}\text{C}$	
V_{DD}	Supply voltage on V_{DD} relative to V_{SS}	-0.5	-	+6.0	V	
V_{IO}	DC input voltage	$V_{SS} - 0.5$	-	$V_{DD} + 0.5$	V	
V_{IOZ}	DC voltage applied to tri-state	$V_{SS} - 0.5$	-	$V_{DD} + 0.5$	V	
I_{MIO}	Maximum current into any port pin	-25	-	+50	mA	
ESD	Electrostatic discharge voltage	2000	-	-	V	Human body model ESD.
LU	Latch up current	-	-	200	mA	



Operating Temperature

Table 11. Operating Temperature

Symbol	Description	Min	Typ	Max	Units	Notes
T _A	Ambient temperature	-40	-	+85	°C	
T _J	Junction temperature	-40	-	+100	°C	The temperature rise from ambient to junction is package specific. See Table 49 on page 57 . You must limit the power consumption to comply with this requirement

DC Electrical Characteristics

DC Chip-Level Specifications

Table 12 lists the guaranteed maximum and minimum specifications for the voltage and temperature ranges: 4.75 V to 5.25 V and -40 °C ≤ T_A ≤ 85 °C, 3.0 V to 3.6 V and -40 °C ≤ T_A ≤ 85 °C, or 2.4 V to 3.0 V and -40 °C ≤ T_A ≤ 85 °C, respectively. Typical parameters are measured at 5 V, 3.3 V, and 2.7 V at 25 °C and are for design guidance only.

Table 12. DC Chip-Level Specifications

Symbol	Description	Min	Typ	Max	Units	Notes
V _{DD}	Supply voltage	2.4	-	5.25	V	See DC POR and LVD specifications, Table 27 on page 35
I _{DD}	Supply current	-	5	8	mA	Conditions are V _{DD} = 5.0 V, T _A = 25 °C, CPU = 3 MHz, SYSCLK doubler disabled, VC1 = 1.5 MHz, VC2 = 93.75 kHz, VC3 = 93.75 kHz, analog power = off, SLIMO mode = 0. IMO = 24 MHz
I _{DD3}	Supply current	-	3.3	6.0	mA	Conditions are V _{DD} = 3.3 V, T _A = 25 °C, CPU = 3 MHz, SYSCLK doubler disabled, VC1 = 1.5 MHz, VC2 = 93.75 kHz, VC3 = 93.75 kHz, analog power = off. SLIMO mode = 0. IMO = 24 MHz
I _{DD27}	Supply current	-	2	4	mA	Conditions are V _{DD} = 2.7 V, T _A = 25 °C, CPU = 0.75 MHz, SYSCLK doubler disabled, VC1 = 0.375 MHz, VC2 = 23.44 kHz, VC3 = 0.09 kHz, analog power = off. SLIMO mode = 1. IMO = 6 MHz
I _{SB}	Sleep (mode) current with POR, LVD, sleep timer, and WDT. ^[10]	-	3	6.5	μA	Conditions are with internal slow speed oscillator, V _{DD} = 3.3 V, -40 °C ≤ T _A ≤ 55 °C, analog power = off
I _{SBH}	Sleep (mode) current with POR, LVD, sleep timer, and WDT at high temperature. ^[10]	-	4	25	μA	Conditions are with internal slow speed oscillator, V _{DD} = 3.3 V, 55 °C < T _A ≤ 85 °C, analog power = off
I _{SBXTL}	Sleep (mode) current with POR, LVD, sleep timer, WDT, and external crystal. ^[10]	-	4	7.5	μA	Conditions are with properly loaded, 1 μW max, 32.768 kHz crystal. V _{DD} = 3.3 V, -40 °C ≤ T _A ≤ 55 °C, analog power = off
I _{SBXTLH}	Sleep (Mode) current with POR, LVD, sleep timer, WDT, and external crystal at high temperature. ^[10]	-	5	26	μA	Conditions are with properly loaded, 1 μW max, 32.768 kHz crystal. V _{DD} = 3.3 V, 55 °C < T _A ≤ 85 °C, analog power = off
V _{REF}	Reference voltage (Bandgap)	1.28	1.30	1.32	V	Trimmed for appropriate V _{DD} . V _{DD} > 3.0 V
V _{REF27}	Reference voltage (Bandgap)	1.16	1.30	1.32	V	Trimmed for appropriate V _{DD} . V _{DD} = 2.4 V to 3.0 V

Note

10. Standby current includes all functions (POR, LVD, WDT, sleep time) needed for reliable system operation. This must be compared with devices that have similar functions enabled.



DC GPIO Specifications

The following tables list the guaranteed maximum and minimum specifications for the voltage and temperature ranges: 4.75 V to 5.25 V and $-40\text{ }^{\circ}\text{C} \leq T_A \leq 85\text{ }^{\circ}\text{C}$, 3.0 V to 3.6 V and $-40\text{ }^{\circ}\text{C} \leq T_A \leq 85\text{ }^{\circ}\text{C}$, or 2.4 V to 3.0 V and $-40\text{ }^{\circ}\text{C} \leq T_A \leq 85\text{ }^{\circ}\text{C}$, respectively. Typical parameters are measured at 5 V, 3.3 V, and 2.7 V at 25 °C and are for design guidance only.

Table 13. 5 V and 3.3 V DC GPIO Specifications

Symbol	Description	Min	Typ	Max	Units	Notes
R _{PU}	Pull-up resistor	4	5.6	8	kΩ	
R _{PD}	Pull-down resistor	4	5.6	8	kΩ	
V _{OH}	High output level	V _{DD} - 1.0	–	–	V	I _{OH} = 10 mA, V _{DD} = 4.75 to 5.25 V (maximum 40 mA on even port pins (for example, P0[2], P1[4]), maximum 40 mA on odd port pins (for example, P0[3], P1[5])). 80 mA maximum combined I _{OH} budget.
V _{OL}	Low output level	–	–	0.75	V	I _{OL} = 25 mA, V _{DD} = 4.75 to 5.25 V (maximum 100 mA on even port pins (for example, P0[2], P1[4]), maximum 100 mA on odd port pins (for example, P0[3], P1[5])). 150 mA maximum combined I _{OL} budget.
I _{OH}	High level source current	10	–	–	mA	V _{OH} = V _{DD} - 1.0 V, see the limitations of the total current in the note for V _{OH}
I _{OL}	Low level sink current	25	–	–	mA	V _{OL} = 0.75 V, see the limitations of the total current in the note for V _{OL}
V _{IL}	Input low level	–	–	0.8	V	V _{DD} = 3.0 to 5.25
V _{IH}	Input high level	2.1	–	–	V	V _{DD} = 3.0 to 5.25
V _H	Input hysteresis	–	60	–	mV	
I _{IL}	Input leakage (absolute value)	–	1	–	nA	Gross tested to 1 μA
C _{IN}	Capacitive load on pins as input	–	3.5	10	pF	Package and pin dependent. Temp = 25 °C
C _{OUT}	Capacitive load on pins as output	–	3.5	10	pF	Package and pin dependent. Temp = 25 °C

Table 14. 2.7 V DC GPIO Specifications

Symbol	Description	Min	Typ	Max	Units	Notes
R _{PU}	Pull-up resistor	4	5.6	8	kΩ	
R _{PD}	Pull-down resistor	4	5.6	8	kΩ	
V _{OH}	High output level	V _{DD} - 0.4	–	–	V	I _{OH} = 2 mA (6.25 Typ), V _{DD} = 2.4 to 3.0 V (16 mA maximum, 50 mA Typ combined I _{OH} budget).
V _{OL}	Low output level	–	–	0.75	V	I _{OL} = 11.25 mA, V _{DD} = 2.4 to 3.0 V (90 mA maximum combined I _{OL} budget).
I _{OH}	High level source current	2	–	–	mA	V _{OH} = V _{DD} - 0.4, see the limitations of total current in note for V _{OH} .
V _{IL}	Input low level	–	–	0.75	V	V _{DD} = 2.4 to 3.0
V _{IH}	Input high level	2.0	–	–	V	V _{DD} = 2.4 to 3.0
V _H	Input hysteresis	–	90	–	mV	
I _{OL}	Low level sink current	11.25	–	–	mA	V _{OL} = .75, see the limitations of total current in note for V _{OL} .
I _{IL}	Input leakage (absolute value)	–	1	–	nA	Gross tested to 1 μA
C _{IN}	Capacitive load on pins as input	–	3.5	10	pF	Package and pin dependent. Temp = 25 °C
C _{OUT}	Capacitive load on pins as output	–	3.5	10	pF	Package and pin dependent. Temp = 25 °C



DC Operational Amplifier Specifications

The following tables list the guaranteed maximum and minimum specifications for the voltage and temperature ranges: 4.75 V to 5.25 V and $-40\text{ }^{\circ}\text{C} \leq T_A \leq 85\text{ }^{\circ}\text{C}$, 3.0 V to 3.6 V and $-40\text{ }^{\circ}\text{C} \leq T_A \leq 85\text{ }^{\circ}\text{C}$, or 2.4 V to 3.0 V and $-40\text{ }^{\circ}\text{C} \leq T_A \leq 85\text{ }^{\circ}\text{C}$, respectively. Typical parameters are measured at 5 V, 3.3 V, and 2.7 V at 25 °C and are for design guidance only.

The operational amplifier is a component of both the analog continuous time PSoC blocks and the Analog Switched Cap PSoC blocks. The guaranteed specifications are measured in the analog continuous time PSoC block. Typical parameters are measured at 5 V at 25 °C and are for design guidance only.

Table 15. 5 V DC Operational Amplifier Specifications

Symbol	Description	Min	Typ	Max	Units	Notes
V_{OSOA}	Input offset voltage (absolute value)	–	1.6	10	mV	
	Power = low, Opamp bias = high	–	1.3	8	mV	
	Power = medium, Opamp bias = high	–	1.2	7.5	mV	
	Power = high, Opamp bias = high	–	–	–	–	
TCV_{OSOA}	Average input offset voltage drift	–	7.0	35.0	$\mu\text{V}/^{\circ}\text{C}$	
I_{EBOA}	Input leakage current (port 0 analog pins)	–	20	–	pA	Gross tested to 1 μA
C_{INOA}	Input capacitance (port 0 analog pins)	–	4.5	9.5	pF	Package and pin dependent. Temp = 25 °C
V_{CMOA}	Common mode voltage range	0.0	–	V_{DD}	V	The common mode input voltage range is measured through an analog output buffer. The specification includes the limitations imposed by the characteristics of the analog output buffer.
	Common mode voltage range (high power or high Opamp bias)	0.5	–	$V_{\text{DD}} - 0.5$	V	
G_{OLOA}	Open loop gain	–	–	–	dB	Specification is applicable at high Opamp bias. For low Opamp bias mode, minimum is 60 dB.
	Power = low, Opamp bias = high	60	–	–	dB	
	Power = medium, Opamp bias = high	60	–	–	dB	
V_{OHIGHOA}	High output voltage swing (internal signals)	–	–	–	V	
	Power = low, Opamp bias = high	$V_{\text{DD}} - 0.2$	–	–	V	
	Power = medium, Opamp bias = high	$V_{\text{DD}} - 0.2$	–	–	V	
V_{OLOWOA}	Low output voltage swing (internal signals)	–	–	0.2	V	
	Power = low, Opamp bias = high	–	–	0.2	V	
	Power = medium, Opamp bias = high	–	–	0.5	V	
I_{SOA}	Supply current (including associated AGND buffer)	–	150	200	μA	
	Power = low, Opamp bias = low	–	300	400	μA	
	Power = low, Opamp bias = high	–	600	800	μA	
	Power = medium, Opamp bias = low	–	1200	1600	μA	
	Power = medium, Opamp bias = high	–	2400	3200	μA	
	Power = high, Opamp bias = high	–	4600	6400	μA	
PSRR_{OA}	Supply voltage rejection ratio	64	80	–	dB	$V_{\text{SS}} \leq V_{\text{IN}} \leq (V_{\text{DD}} - 2.25)$ or $(V_{\text{DD}} - 1.25\text{ V}) \leq V_{\text{IN}} \leq V_{\text{DD}}$

Table 16. 3.3 V DC Operational Amplifier Specifications

Symbol	Description	Min	Typ	Max	Units	Notes
V_{OSOA}	Input offset voltage (absolute value) Power = low, Opamp bias = high Power = medium, Opamp bias = high Power = high, Opamp bias = high	–	1.65 1.32 –	10 8 –	mV mV mV	Power = high, Opamp bias = high setting is not allowed for 3.3 V V_{DD} operation.
TCV_{OSOA}	Average input offset voltage drift	–	7.0	35.0	$\mu V/^{\circ}C$	
I_{EBOA}	Input leakage current (port 0 analog pins)	–	20	–	pA	Gross tested to 1 μA
C_{INOA}	Input capacitance (port 0 analog pins)	–	4.5	9.5	pF	Package and pin dependent. Temp = 25 $^{\circ}C$
V_{CMOA}	Common mode voltage range	0.2	–	$V_{DD} - 0.2$	V	The common-mode input voltage range is measured through an analog output buffer. The specification includes the limitations imposed by the characteristics of the analog output buffer.
G_{OLOA}	Open loop gain Power = low, ppamp Opamp bias = low Power = medium, Opamp bias = low Power = high, Opamp bias = low	60 60 80	– – –	– – –	dB dB dB	Specification is applicable at low Opamp bias. For high Opamp bias mode (except high power, high Opamp bias), minimum is 60 dB.
$V_{OHIGHOA}$	High output voltage swing (internal signals) Power = low, Opamp bias = low Power = medium, Opamp bias = low Power = high, Opamp bias = low	$V_{DD} - 0.2$ $V_{DD} - 0.2$ $V_{DD} - 0.2$	– – –	– – –	V V V	Power = high, Opamp bias = high setting is not allowed for 3.3 V V_{DD} operation.
V_{OLOWOA}	Low output voltage swing (internal signals) Power = low, ppamp Opamp bias = low Power = medium, Opamp bias = low Power = high, Opamp bias = low	– – –	– – –	0.2 0.2 0.2	V V V	Power = high, Opamp bias = high setting is not allowed for 3.3 V V_{DD} operation.
I_{SOA}	Supply current (including associated AGND buffer) Power = low, Opamp bias = low Power = low, Opamp bias = high Power = medium, Opamp bias = low Power = medium, Opamp bias = high Power = high, Opamp bias = low Power = high, Opamp bias = high	– – – – – –	150 300 600 1200 2400 –	200 400 800 1600 3200 –	μA μA μA μA μA μA	Power = high, Opamp bias = high setting is not allowed for 3.3 V V_{DD} operation.
$PSRR_{OA}$	Supply voltage rejection ratio	64	80	–	dB	$V_{SS} \leq V_{IN} \leq (V_{DD} - 2.25)$ or $(V_{DD} - 1.25 V) \leq V_{IN} \leq V_{DD}$



Table 17. 2.7 V DC Operational Amplifier Specifications

Symbol	Description	Min	Typ	Max	Units	Notes
V_{OSOA}	Input offset voltage (absolute value) Power = low, Opamp bias = high Power = medium, Opamp bias = high Power = high, Opamp bias = high	– – –	1.65 1.32 –	10 8 –	mV mV mV	Power = high, Opamp bias = high setting is not allowed for 2.7 V V_{DD} operation.
TCV_{OSOA}	Average input offset voltage drift	–	7.0	35.0	$\mu V/^\circ C$	
I_{EBOA}	Input leakage current (port 0 analog pins)	–	20	–	pA	Gross tested to 1 μA
C_{INOA}	Input capacitance (port 0 analog pins)	–	4.5	9.5	pF	Package and pin dependent. Temp = 25 $^\circ C$
V_{CMOA}	Common mode voltage range	0.2	–	$V_{DD} - 0.2$	V	The common-mode input voltage range is measured through an analog output buffer. The specification includes the limitations imposed by the characteristics of the analog output buffer.
G_{OLOA}	Open loop gain Power = low, Opamp bias = low Power = medium, Opamp bias = low Power = high, Opamp bias = low	60 60 80	– – –	– – –	dB dB dB	Specification is applicable at low Opamp bias. For high Opamp bias mode, (except high power, high Opamp bias), minimum is 60 dB.
$V_{OHIGHOA}$	High output voltage swing (internal signals) Power = low, Opamp bias = low Power = medium, Opamp bias = low Power = high, Opamp bias = low	$V_{DD} - 0.2$ $V_{DD} - 0.2$ $V_{DD} - 0.2$	– – –	– – –	V V V	Power = high, Opamp bias = high setting is not allowed for 2.7 V V_{DD} operation.
V_{OLOWOA}	Low output voltage swing (internal signals) Power = low, Opamp bias = low Power = medium, Opamp bias = low Power = high, Opamp bias = low	– – –	– – –	0.2 0.2 0.2	V V V	Power = high, Opamp bias = high setting is not allowed for 2.7 V V_{DD} operation.
I_{SOA}	Supply current (including associated AGND buffer) Power = low, Opamp bias = low Power = low, Opamp bias = high Power = medium, Opamp bias = low Power = medium, Opamp bias = high Power = high, Opamp bias = low Power = high, Opamp bias = high	– – – – – –	150 300 600 1200 2400 –	200 400 800 1600 3200 –	μA μA μA μA μA μA	Power = high, Opamp bias = high setting is not allowed for 2.7 V V_{DD} operation.
$PSRR_{OA}$	Supply voltage rejection ratio	64	80	–	dB	$V_{SS} \leq V_{IN} \leq (V_{DD} - 2.25)$ or $(V_{DD} - 1.25 V) \leq V_{IN} \leq V_{DD}$

DC Low Power Comparator Specifications

Table 18 lists the guaranteed maximum and minimum specifications for the voltage and temperature ranges: 4.75 V to 5.25 V and $-40^\circ C \leq T_A \leq 85^\circ C$, 3.0 V to 3.6 V and $-40^\circ C \leq T_A \leq 85^\circ C$, or 2.4 V to 3.0 V and $-40^\circ C \leq T_A \leq 85^\circ C$, respectively. Typical parameters are measured at 5 V at 25 $^\circ C$ and are for design guidance only.

Table 18. DC Low Power Comparator Specifications

Symbol	Description	Min	Typ	Max	Units	Notes
V_{REFLPC}	Low power comparator (LPC) reference voltage range	0.2	–	$V_{DD} - 1$	V	
I_{SLPC}	LPC supply current	–	10	40	μA	
V_{OSLPC}	LPC voltage offset	–	2.5	30	mV	



DC Analog Output Buffer Specifications

The following tables list the guaranteed maximum and minimum specifications for the voltage and temperature ranges: 4.75 V to 5.25 V and $-40\text{ }^{\circ}\text{C} \leq T_A \leq 85\text{ }^{\circ}\text{C}$, 3.0 V to 3.6 V and $-40\text{ }^{\circ}\text{C} \leq T_A \leq 85\text{ }^{\circ}\text{C}$, or 2.4 V to 3.0 V and $-40\text{ }^{\circ}\text{C} \leq T_A \leq 85\text{ }^{\circ}\text{C}$, respectively. Typical parameters are measured at 5 V, 3.3 V, and 2.7 V at 25 °C and are for design guidance only.

Table 19. 5 V DC Analog Output Buffer Specifications

Symbol	Description	Min	Typ	Max	Units	Notes
C_L	Load Capacitance	–	–	200	pF	This specification applies to the external circuit that is being driven by the analog output buffer.
V_{OSOB}	Input offset voltage (absolute value)	–	3	12	mV	
TCV_{OSOB}	Average input offset voltage drift	–	+6	–	$\mu\text{V}/^{\circ}\text{C}$	
V_{CMOB}	Common mode input voltage range	0.5	–	$V_{DD} - 1.0$	V	
R_{OUTOB}	Output resistance Power = low Power = high	– –	1 1	– –	W W	
$V_{OHIGHOB}$	High output voltage swing (Load = 32 ohms to $V_{DD/2}$) Power = low Power = high	$0.5 \times V_{DD} + 1.1$ $0.5 \times V_{DD} + 1.1$	– –	– –	V V	
V_{OLOWOB}	Low output voltage swing (Load = 32 ohms to $V_{DD/2}$) Power = low Power = high	– –	– –	$.5 \times V_{DD} - 1.3$ $0.5 \times V_{DD} - 1.3$	V V	
I_{SOB}	Supply current including Opamp bias cell (No Load) Power = low Power = high	– –	1.1 2.6	5.1 8.8	mA mA	
$PSRR_{OB}$	Supply voltage rejection ratio	52	64	–	dB	$V_{OUT} > (V_{DD} - 1.25)$

Table 20. 3.3 V DC Analog Output Buffer Specifications

Symbol	Description	Min	Typ	Max	Units	Notes
C_L	Load Capacitance	–	–	200	pF	This specification applies to the external circuit that is being driven by the analog output buffer.
V_{OSOB}	Input offset voltage (absolute value)	–	3	12	mV	
TCV_{OSOB}	Average input offset voltage drift	–	+6	–	$\mu\text{V}/^{\circ}\text{C}$	
V_{CMOB}	Common mode input voltage range	0.5	–	$V_{DD} - 1.0$	V	
R_{OUTOB}	Output resistance Power = low Power = high	– –	1 1	– –	Ω Ω	
$V_{OHIGHOB}$	High output voltage swing (Load = 1 K ohms to $V_{DD/2}$) Power = low Power = high	$0.5 \times V_{DD} + 1.0$ $0.5 \times V_{DD} + 1.0$	– –	– –	V V	
V_{OLOWOB}	Low output voltage swing (Load = 1 K ohms to $V_{DD/2}$) Power = low Power = high	– –	– –	$0.5 \times V_{DD} - 1.0$ $0.5 \times V_{DD} - 1.0$	V V	
I_{SOB}	Supply current including Opamp bias cell (no load) Power = low Power = high	– –	0.8 2.0	2.0 4.3	mA mA	
$PSRR_{OB}$	Supply voltage rejection ratio	52	64	–	dB	$V_{OUT} > (V_{DD} - 1.25)$

Table 21. 2.7 V DC Analog Output Buffer Specifications

Symbol	Description	Min	Typ	Max	Units	Notes
C_L	Load Capacitance	–	–	200	pF	This specification applies to the external circuit that is being driven by the analog output buffer.
V_{OSOB}	Input offset voltage (absolute value)	–	3	12	mV	
TCV_{OSOB}	Average input offset voltage drift	–	+6	–	$\mu\text{V}/^\circ\text{C}$	
V_{CMOB}	Common mode input voltage range	0.5	–	$V_{DD} - 1.0$	V	
R_{OUTOB}	Output resistance Power = low Power = high	– –	1 1	– –	Ω Ω	
$V_{OHIGHOB}$	High output voltage swing (Load = 1 K ohms to $V_{DD}/2$) Power = low Power = high	$0.5 \times V_{DD} + 0.2$ $0.5 \times V_{DD} + 0.2$	– –	– –	V V	
V_{LOWOB}	Low output voltage swing (Load = 1 K ohms to $V_{DD}/2$) Power = low Power = high	– –	– –	$0.5 \times V_{DD} - 0.7$ $0.5 \times V_{DD} - 0.7$	V V	
I_{SOB}	Supply current including Opamp bias cell (No Load) Power = low Power = high	–	0.8 2.0	2.0 4.3	mA mA	
$PSRR_{OB}$	Supply voltage rejection ratio	52	64	–	dB	$V_{OUT} > (V_{DD} - 1.25)$.

DC Switch Mode Pump Specifications

Table 22 lists the guaranteed maximum and minimum specifications for the voltage and temperature ranges: 4.75 V to 5.25 V and $-40\text{ }^{\circ}\text{C} \leq T_A \leq 85\text{ }^{\circ}\text{C}$, 3.0 V to 3.6 V and $-40\text{ }^{\circ}\text{C} \leq T_A \leq 85\text{ }^{\circ}\text{C}$, or 2.4 V to 3.0 V and $-40\text{ }^{\circ}\text{C} \leq T_A \leq 85\text{ }^{\circ}\text{C}$, respectively. Typical parameters are measured at 5 V, 3.3 V, and 2.7 V at 25 °C and are for design guidance only.

Table 22. DC Switch Mode Pump (SMP) Specifications

Symbol	Description	Min	Typ	Max	Units	Notes
$V_{\text{PUMP } 5\text{ V}}$	5 V output voltage from pump	4.75	5.0	5.25	V	Configuration listed in footnote. ^[11] Average, neglecting ripple. SMP trip voltage is set to 5.0 V.
$V_{\text{PUMP } 3\text{ V}}$	3.3 V output voltage from pump	3.00	3.25	3.60	V	Configuration listed in footnote. ^[11] Average, neglecting ripple. SMP trip voltage is set to 3.25 V.
$V_{\text{PUMP } 2\text{ V}}$	2.6 V output voltage from pump	2.45	2.55	2.80	V	Configuration listed in footnote. ^[11] Average, neglecting ripple. SMP trip voltage is set to 2.55 V.
I_{PUMP}	Available output current $V_{\text{BAT}} = 1.8\text{ V}, V_{\text{PUMP}} = 5.0\text{ V}$ $V_{\text{BAT}} = 1.5\text{ V}, V_{\text{PUMP}} = 3.25\text{ V}$ $V_{\text{BAT}} = 1.3\text{ V}, V_{\text{PUMP}} = 2.55\text{ V}$	5 8 8	– – –	– – –	mA mA mA	Configuration listed in footnote. ^[11] SMP trip voltage is set to 5.0 V. SMP trip voltage is set to 3.25 V. SMP trip voltage is set to 2.55 V.
$V_{\text{BAT}5\text{ V}}$	Input voltage range from battery	1.8	–	5.0	V	Configuration listed in footnote. ^[11] SMP trip voltage is set to 5.0 V.
$V_{\text{BAT}3\text{ V}}$	Input voltage range from battery	1.0	–	3.3	V	Configuration listed in footnote. ^[11] SMP trip voltage is set to 3.25 V.
$V_{\text{BAT}2\text{ V}}$	Input voltage range from battery	1.0	–	3.0	V	Configuration listed in footnote. ^[11] SMP trip voltage is set to 2.55 V.
V_{BATSTART}	Minimum input voltage from battery to start pump	1.2	–	–	V	Configuration listed in footnote. ^[11] $0\text{ }^{\circ}\text{C} \leq T_A \leq 100$. 1.25 V at $T_A = -40\text{ }^{\circ}\text{C}$
$\Delta V_{\text{PUMP_Line}}$	Line regulation (over V_{BAT} range)	–	5	–	% V_{O}	Configuration listed in footnote. ^[11] V_{O} is the V_{DD} Value for PUMP Trip” specified by the VM[2:0] setting in the DC POR and LVD Specification, Table 27 on page 35 .
$\Delta V_{\text{PUMP_Load}}$	Load regulation	–	5	–	% V_{O}	Configuration listed in footnote. ^[11] V_{O} is the “ V_{DD} value for PUMP Trip” specified by the VM[2:0] setting in the DC POR and LVD Specification, Table 27 on page 35 .
$\Delta V_{\text{PUMP_Ripple}}$	Output voltage ripple (depends on capacitor/load)	–	100	–	mVpp	Configuration listed in footnote. ^[11] Load is 5 mA.
E_3	Efficiency	35	50	–	%	Configuration listed in footnote. ^[11] Load is 5 mA. SMP trip voltage is set to 3.25 V.
E_2	Efficiency	–	–	–		
F_{PUMP}	Switching frequency	–	1.3	–	MHz	
DC_{PUMP}	Switching duty cycle	–	50	–	%	

Note

11. $L_1 = 2\text{ mH}$ inductor, $C_1 = 10\text{ mF}$ capacitor, $D_1 =$ Schottky diode. See [Figure 11](#)

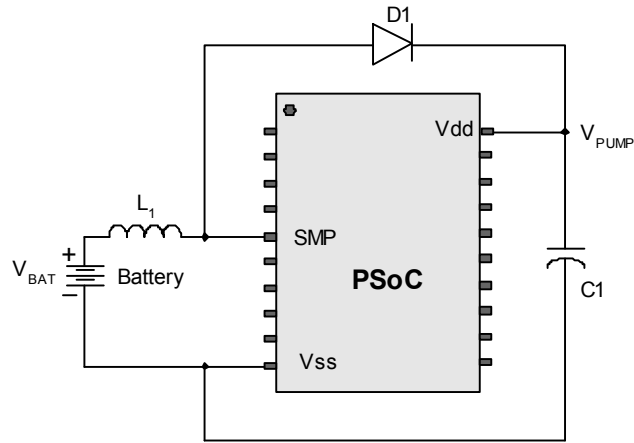
Figure 11. Basic Switch Mode Pump Circuit



DC Analog Reference Specifications

The following tables list the guaranteed maximum and minimum specifications for the voltage and temperature ranges: 4.75 V to 5.25 V and $-40\text{ }^{\circ}\text{C} \leq T_A \leq 85\text{ }^{\circ}\text{C}$, 3.0 V to 3.6 V and $-40\text{ }^{\circ}\text{C} \leq T_A \leq 85\text{ }^{\circ}\text{C}$, or 2.4 V to 3.0 V and $-40\text{ }^{\circ}\text{C} \leq T_A \leq 85\text{ }^{\circ}\text{C}$, respectively. Typical parameters are measured at 5 V, 3.3 V, and 2.7 V at 25 °C and are for design guidance only.

The guaranteed specifications for RefHi and RefLo are measured through the Analog Continuous Time PSoC blocks. The power levels for RefHi and RefLo refer to the Analog Reference Control register. AGND is measured at P2[4] in AGND bypass mode. Each Analog Continuous Time PSoC block adds a maximum of 10 mV additional offset error to guaranteed AGND specifications from the local AGND buffer. Reference control power can be set to medium or high unless otherwise noted.

Note Avoid using P2[4] for digital signaling when using an analog resource that depends on the analog reference. Some coupling of the digital signal may appear on the AGND.

Table 23. 5 V DC Analog Reference Specifications

Reference ARF_CR [5:3]	Reference Power Settings	Symbol	Reference	Description	Min	Typ	Max	Units
0b000	RefPower = high Opamp bias = high	V _{REFHI}	Ref High	V _{DD} /2 + Bandgap	V _{DD} /2 + 1.136	V _{DD} /2 + 1.288	V _{DD} /2 + 1.409	V
		V _{AGND}	AGND	V _{DD} /2	V _{DD} /2 – 0.138	V _{DD} /2 + 0.003	V _{DD} /2 + 0.132	V
		V _{REFLO}	Ref Low	V _{DD} /2 – Bandgap	V _{DD} /2 – 1.417	V _{DD} /2 – 1.289	V _{DD} /2 – 1.154	V
	RefPower = high Opamp bias = low	V _{REFHI}	Ref High	V _{DD} /2 + Bandgap	V _{DD} /2 + 1.202	V _{DD} /2 + 1.290	V _{DD} /2 + 1.358	V
		V _{AGND}	AGND	V _{DD} /2	V _{DD} /2 – 0.055	V _{DD} /2 + 0.001	V _{DD} /2 + 0.055	V
		V _{REFLO}	Ref Low	V _{DD} /2 – Bandgap	V _{DD} /2 – 1.369	V _{DD} /2 – 1.295	V _{DD} /2 – 1.218	V
	RefPower = medium Opamp bias = high	V _{REFHI}	Ref High	V _{DD} /2 + Bandgap	V _{DD} /2 + 1.211	V _{DD} /2 + 1.292	V _{DD} /2 + 1.357	V
		V _{AGND}	AGND	V _{DD} /2	V _{DD} /2 – 0.055	V _{DD} /2	V _{DD} /2 + 0.052	V
		V _{REFLO}	Ref Low	V _{DD} /2 – Bandgap	V _{DD} /2 – 1.368	V _{DD} /2 – 1.298	V _{DD} /2 – 1.224	V
	RefPower = medium Opamp bias = low	V _{REFHI}	Ref High	V _{DD} /2 + Bandgap	V _{DD} /2 + 1.215	V _{DD} /2 + 1.292	V _{DD} /2 + 1.353	V
		V _{AGND}	AGND	V _{DD} /2	V _{DD} /2 – 0.040	V _{DD} /2 – 0.001	V _{DD} /2 + 0.033	V
		V _{REFLO}	Ref Low	V _{DD} /2 – Bandgap	V _{DD} /2 – 1.368	V _{DD} /2 – 1.299	V _{DD} /2 – 1.225	V
0b001	RefPower = high Opamp bias = high	V _{REFHI}	Ref High	P2[4]+P2[6] (P2[4] = V _{DD} /2, P2[6] = 1.3 V)	P2[4] + P2[6] – 0.076	P2[4] + P2[6] – 0.021	P2[4] + P2[6] + 0.041	V
		V _{AGND}	AGND	P2[4]	P2[4]	P2[4]	P2[4]	–
		V _{REFLO}	Ref Low	P2[4]–P2[6] (P2[4] = V _{DD} /2, P2[6] = 1.3 V)	P2[4] – P2[6] – 0.025	P2[4] – P2[6] + 0.011	P2[4] – P2[6] + 0.085	V
	RefPower = high Opamp bias = low	V _{REFHI}	Ref High	P2[4]+P2[6] (P2[4] = V _{DD} /2, P2[6] = 1.3 V)	P2[4] + P2[6] – 0.069	P2[4] + P2[6] – 0.014	P2[4] + P2[6] + 0.043	V
		V _{AGND}	AGND	P2[4]	P2[4]	P2[4]	P2[4]	–
		V _{REFLO}	Ref Low	P2[4]–P2[6] (P2[4] = V _{DD} /2, P2[6] = 1.3 V)	P2[4] – P2[6] – 0.029	P2[4] – P2[6] + 0.005	P2[4] – P2[6] + 0.052	V
	RefPower = medium Opamp bias = high	V _{REFHI}	Ref High	P2[4]+P2[6] (P2[4] = V _{DD} /2, P2[6] = 1.3 V)	P2[4] + P2[6] – 0.072	P2[4] + P2[6] – 0.011	P2[4] + P2[6] + 0.048	V
		V _{AGND}	AGND	P2[4]	P2[4]	P2[4]	P2[4]	–
		V _{REFLO}	Ref Low	P2[4]–P2[6] (P2[4] = V _{DD} /2, P2[6] = 1.3 V)	P2[4] – P2[6] – 0.031	P2[4] – P2[6] + 0.002	P2[4] – P2[6] + 0.057	V
	RefPower = medium Opamp bias = low	V _{REFHI}	Ref High	P2[4]+P2[6] (P2[4] = V _{DD} /2, P2[6] = 1.3 V)	P2[4] + P2[6] – 0.070	P2[4] + P2[6] – 0.009	P2[4] + P2[6] + 0.047	V
		V _{AGND}	AGND	P2[4]	P2[4]	P2[4]	P2[4]	–
		V _{REFLO}	Ref Low	P2[4]–P2[6] (P2[4] = V _{DD} /2, P2[6] = 1.3 V)	P2[4] – P2[6] – 0.033	P2[4] – P2[6] + 0.001	P2[4] – P2[6] + 0.039	V

Table 23. 5 V DC Analog Reference Specifications (continued)

Reference ARF_CR [5:3]	Reference Power Settings	Symbol	Reference	Description	Min	Typ	Max	Units
0b010	ReffPower = high Opamp bias = high	V _{REFHI}	Ref High	V _{DD}	V _{DD} - 0.121	V _{DD} - 0.003	V _{DD}	V
		V _{AGND}	AGND	V _{DD} /2	V _{DD} /2 - 0.040	V _{DD} /2	V _{DD} /2 + 0.034	V
		V _{REFLO}	Ref Low	V _{SS}	V _{SS}	V _{SS} + 0.006	V _{SS} + 0.019	V
	ReffPower = high Opamp bias = low	V _{REFHI}	Ref High	V _{DD}	V _{DD} - 0.083	V _{DD} - 0.002	V _{DD}	V
		V _{AGND}	AGND	V _{DD} /2	V _{DD} /2 - 0.040	V _{DD} /2 - 0.001	V _{DD} /2 + 0.033	V
		V _{REFLO}	Ref Low	V _{SS}	V _{SS}	V _{SS} + 0.004	V _{SS} + 0.016	V
	ReffPower = medium Opamp bias = high	V _{REFHI}	Ref High	V _{DD}	V _{DD} - 0.075	V _{DD} - 0.002	V _{DD}	V
		V _{AGND}	AGND	V _{DD} /2	V _{DD} /2 - 0.040	V _{DD} /2 - 0.001	V _{DD} /2 + 0.032	V
		V _{REFLO}	Ref Low	V _{SS}	V _{SS}	V _{SS} + 0.003	V _{SS} + 0.015	V
ReffPower = medium Opamp bias = low	V _{REFHI}	Ref High	V _{DD}	V _{DD} - 0.074	V _{DD} - 0.002	V _{DD}	V	
	V _{AGND}	AGND	V _{DD} /2	V _{DD} /2 - 0.040	V _{DD} /2 - 0.001	V _{DD} /2 + 0.032	V	
	V _{REFLO}	Ref Low	V _{SS}	V _{SS}	V _{SS} + 0.002	V _{SS} + 0.014	V	
0b011	ReffPower = high Opamp bias = high	V _{REFHI}	Ref High	3 × Bandgap	3.753	3.874	3.979	V
		V _{AGND}	AGND	2 × Bandgap	2.511	2.590	2.657	V
		V _{REFLO}	Ref Low	Bandgap	1.243	1.297	1.333	V
	ReffPower = high Opamp bias = low	V _{REFHI}	Ref High	3 × Bandgap	3.767	3.881	3.974	V
		V _{AGND}	AGND	2 × Bandgap	2.518	2.592	2.652	V
		V _{REFLO}	Ref Low	Bandgap	1.241	1.295	1.330	V
	ReffPower = medium Opamp bias = high	V _{REFHI}	Ref High	3 × Bandgap	2.771	3.885	3.979	V
		V _{AGND}	AGND	2 × Bandgap	2.521	2.593	2.649	V
		V _{REFLO}	Ref Low	Bandgap	1.240	1.295	1.331	V
ReffPower = medium Opamp bias = low	V _{REFHI}	Ref High	3 × Bandgap	3.771	3.887	3.977	V	
	V _{AGND}	AGND	2 × Bandgap	2.522	2.594	2.648	V	
	V _{REFLO}	Ref Low	Bandgap	1.239	1.295	1.332	V	
0b100	ReffPower = high Opamp bias = high	V _{REFHI}	Ref High	2 × Bandgap + P2[6] (P2[6] = 1.3 V)	2.481 + P2[6]	2.569 + P2[6]	2.639 + P2[6]	V
		V _{AGND}	AGND	2 × Bandgap	2.511	2.590	2.658	V
		V _{REFLO}	Ref Low	2 × Bandgap - P2[6] (P2[6] = 1.3 V)	2.515 - P2[6]	2.602 - P2[6]	2.654 - P2[6]	V
	ReffPower = high Opamp bias = low	V _{REFHI}	Ref High	2 × Bandgap + P2[6] (P2[6] = 1.3 V)	2.498 + P2[6]	2.579 + P2[6]	2.642 + P2[6]	V
		V _{AGND}	AGND	2 × Bandgap	2.518	2.592	2.652	V
		V _{REFLO}	Ref Low	2 × Bandgap - P2[6] (P2[6] = 1.3 V)	2.513 - P2[6]	2.598 - P2[6]	2.650 - P2[6]	V
	ReffPower = medium Opamp bias = high	V _{REFHI}	Ref High	2 × Bandgap + P2[6] (P2[6] = 1.3 V)	2.504 + P2[6]	2.583 + P2[6]	2.646 + P2[6]	V
		V _{AGND}	AGND	2 × Bandgap	2.521	2.592	2.650	V
		V _{REFLO}	Ref Low	2 × Bandgap - P2[6] (P2[6] = 1.3 V)	2.513 - P2[6]	2.596 - P2[6]	2.649 - P2[6]	V
ReffPower = medium Opamp bias = low	V _{REFHI}	Ref High	2 × Bandgap + P2[6] (P2[6] = 1.3 V)	2.505 + P2[6]	2.586 + P2[6]	2.648 + P2[6]	V	
	V _{AGND}	AGND	2 × Bandgap	2.521	2.594	2.648	V	
	V _{REFLO}	Ref Low	2 × Bandgap - P2[6] (P2[6] = 1.3 V)	2.513 - P2[6]	2.595 - P2[6]	2.648 - P2[6]	V	

Table 23. 5 V DC Analog Reference Specifications (continued)

Reference ARF_CR [5:3]	Reference Power Settings	Symbol	Reference	Description	Min	Typ	Max	Units
0b101	RefPower = high Opamp bias = high	V _{REFHI}	Ref High	P2[4] + Bandgap (P2[4] = V _{DD} /2)	P2[4] + 1.228	P2[4] + 1.284	P2[4] + 1.332	V
		V _{AGND}	AGND	P2[4]	P2[4]	P2[4]	P2[4]	–
		V _{REFLO}	Ref Low	P2[4] – Bandgap (P2[4] = V _{DD} /2)	P2[4] – 1.358	P2[4] – 1.293	P2[4] – 1.226	V
	RefPower = high Opamp bias = low	V _{REFHI}	Ref High	P2[4] + Bandgap (P2[4] = V _{DD} /2)	P2[4] + 1.236	P2[4] + 1.289	P2[4] + 1.332	V
		V _{AGND}	AGND	P2[4]	P2[4]	P2[4]	P2[4]	–
		V _{REFLO}	Ref Low	P2[4] – Bandgap (P2[4] = V _{DD} /2)	P2[4] – 1.357	P2[4] – 1.297	P2[4] – 1.229	V
	RefPower = medium Opamp bias = high	V _{REFHI}	Ref High	P2[4] + Bandgap (P2[4] = V _{DD} /2)	P2[4] + 1.237	P2[4] + 1.291	P2[4] + 1.337	V
		V _{AGND}	AGND	P2[4]	P2[4]	P2[4]	P2[4]	–
		V _{REFLO}	Ref Low	P2[4] – Bandgap (P2[4] = V _{DD} /2)	P2[4] – 1.356	P2[4] – 1.299	P2[4] – 1.232	V
	RefPower = medium Opamp bias = low	V _{REFHI}	Ref High	P2[4] + Bandgap (P2[4] = V _{DD} /2)	P2[4] + 1.237	P2[4] + 1.292	P2[4] + 1.337	V
		V _{AGND}	AGND	P2[4]	P2[4]	P2[4]	P2[4]	–
		V _{REFLO}	Ref Low	P2[4] – Bandgap (P2[4] = V _{DD} /2)	P2[4] – 1.357	P2[4] – 1.300	P2[4] – 1.233	V
0b110	RefPower = high Opamp bias = high	V _{REFHI}	Ref High	2 × Bandgap	2.512	2.594	2.654	V
		V _{AGND}	AGND	Bandgap	1.250	1.303	1.346	V
		V _{REFLO}	Ref Low	V _{SS}	V _{SS}	V _{SS} + 0.011	V _{SS} + 0.027	V
	RefPower = high Opamp bias = low	V _{REFHI}	Ref High	2 × Bandgap	2.515	2.592	2.654	V
		V _{AGND}	AGND	Bandgap	1.253	1.301	1.340	V
		V _{REFLO}	Ref Low	V _{SS}	V _{SS}	V _{SS} + 0.006	V _{SS} + 0.02	V
	RefPower = medium Opamp bias = high	V _{REFHI}	Ref High	2 × Bandgap	2.518	2.593	2.651	V
		V _{AGND}	AGND	Bandgap	1.254	1.301	1.338	V
		V _{REFLO}	Ref Low	V _{SS}	V _{SS}	V _{SS} + 0.004	V _{SS} + 0.017	V
	RefPower = medium Opamp bias = low	V _{REFHI}	Ref High	2 × Bandgap	2.517	2.594	2.650	V
		V _{AGND}	AGND	Bandgap	1.255	1.300	1.337	V
		V _{REFLO}	Ref Low	V _{SS}	V _{SS}	V _{SS} + 0.003	V _{SS} + 0.015	V
0b111	RefPower = high Opamp bias = high	V _{REFHI}	Ref High	3.2 × Bandgap	4.011	4.143	4.203	V
		V _{AGND}	AGND	1.6 × Bandgap	2.020	2.075	2.118	V
		V _{REFLO}	Ref Low	V _{SS}	V _{SS}	V _{SS} + 0.011	V _{SS} + 0.026	V
	RefPower = high Opamp bias = low	V _{REFHI}	Ref High	3.2 × Bandgap	4.022	4.138	4.203	V
		V _{AGND}	AGND	1.6 × Bandgap	2.023	2.075	2.114	V
		V _{REFLO}	Ref Low	V _{SS}	V _{SS}	V _{SS} + 0.006	V _{SS} + 0.017	V
	RefPower = medium Opamp bias = high	V _{REFHI}	Ref High	3.2 × Bandgap	4.026	4.141	4.207	V
		V _{AGND}	AGND	1.6 × Bandgap	2.024	2.075	2.114	V
		V _{REFLO}	Ref Low	V _{SS}	V _{SS}	V _{SS} + 0.004	V _{SS} + 0.015	V
	RefPower = medium Opamp bias = low	V _{REFHI}	Ref High	3.2 × Bandgap	4.030	4.143	4.206	V
		V _{AGND}	AGND	1.6 × Bandgap	2.024	2.076	2.112	V
		V _{REFLO}	Ref Low	V _{SS}	V _{SS}	V _{SS} + 0.003	V _{SS} + 0.013	V



Table 24. 3.3 V DC Analog Reference Specifications

Reference ARF_CR [5:3]	Reference Power Settings	Symbol	Reference	Description	Min	Typ	Max	Units
0b000	RefPower = high Opamp bias = high	V _{REFHI}	Ref High	V _{DD} /2 + Bandgap	V _{DD} /2 + 1.170	V _{DD} /2 + 1.288	V _{DD} /2 + 1.376	V
		V _{AGND}	AGND	V _{DD} /2	V _{DD} /2 - 0.098	V _{DD} /2 + 0.003	V _{DD} /2 + 0.097	V
		V _{REFLO}	Ref Low	V _{DD} /2 - Bandgap	V _{DD} /2 - 1.386	V _{DD} /2 - 1.287	V _{DD} /2 - 1.169	V
	RefPower = high Opamp bias = low	V _{REFHI}	Ref High	V _{DD} /2 + Bandgap	V _{DD} /2 + 1.210	V _{DD} /2 + 1.290	V _{DD} /2 + 1.355	V
		V _{AGND}	AGND	V _{DD} /2	V _{DD} /2 - 0.055	V _{DD} /2 + 0.001	V _{DD} /2 + 0.054	V
		V _{REFLO}	Ref Low	V _{DD} /2 - Bandgap	V _{DD} /2 - 1.359	V _{DD} /2 - 1.292	V _{DD} /2 - 1.214	V
	RefPower = medium Opamp bias = high	V _{REFHI}	Ref High	V _{DD} /2 + Bandgap	V _{DD} /2 + 1.198	V _{DD} /2 + 1.292	V _{DD} /2 + 1.368	V
		V _{AGND}	AGND	V _{DD} /2	V _{DD} /2 - 0.041	V _{DD} /2	V _{DD} /2 + 0.04	V
		V _{REFLO}	Ref Low	V _{DD} /2 - Bandgap	V _{DD} /2 - 1.362	V _{DD} /2 - 1.295	V _{DD} /2 - 1.220	V
	RefPower = medium Opamp bias = low	V _{REFHI}	Ref High	V _{DD} /2 + Bandgap	V _{DD} /2 + 1.202	V _{DD} /2 + 1.292	V _{DD} /2 + 1.364	V
		V _{AGND}	AGND	V _{DD} /2	V _{DD} /2 - 0.033	V _{DD} /2	V _{DD} /2 + 0.030	V
		V _{REFLO}	Ref Low	V _{DD} /2 - Bandgap	V _{DD} /2 - 1.364	V _{DD} /2 - 1.297	V _{DD} /2 - 1.222	V
0b001	RefPower = high Opamp bias = high	V _{REFHI}	Ref High	P2[4]+P2[6] (P2[4] = V _{DD} /2, P2[6] = 0.5 V)	P2[4] + P2[6] - 0.072	P2[4] + P2[6] - 0.017	P2[4] + P2[6] + 0.041	V
		V _{AGND}	AGND	P2[4]	P2[4]	P2[4]	P2[4]	-
		V _{REFLO}	Ref Low	P2[4]-P2[6] (P2[4] = V _{DD} /2, P2[6] = 0.5 V)	P2[4] - P2[6] - 0.029	P2[4] - P2[6] + 0.010	P2[4] - P2[6] + 0.048	V
	RefPower = high Opamp bias = low	V _{REFHI}	Ref High	P2[4]+P2[6] (P2[4] = V _{DD} /2, P2[6] = 0.5 V)	P2[4] + P2[6] - 0.066	P2[4] + P2[6] - 0.010	P2[4] + P2[6] + 0.043	V
		V _{AGND}	AGND	P2[4]	P2[4]	P2[4]	P2[4]	-
		V _{REFLO}	Ref Low	P2[4]-P2[6] (P2[4] = V _{DD} /2, P2[6] = 0.5 V)	P2[4] - P2[6] - 0.024	P2[4] - P2[6] + 0.004	P2[4] - P2[6] + 0.034	V
	RefPower = medium Opamp bias = high	V _{REFHI}	Ref High	P2[4]+P2[6] (P2[4] = V _{DD} /2, P2[6] = 0.5 V)	P2[4] + P2[6] - 0.073	P2[4] + P2[6] - 0.007	P2[4] + P2[6] + 0.053	V
		V _{AGND}	AGND	P2[4]	P2[4]	P2[4]	P2[4]	-
		V _{REFLO}	Ref Low	P2[4]-P2[6] (P2[4] = V _{DD} /2, P2[6] = 0.5 V)	P2[4] - P2[6] - 0.028	P2[4] - P2[6] + 0.002	P2[4] - P2[6] + 0.033	V
	RefPower = medium Opamp bias = low	V _{REFHI}	Ref High	P2[4]+P2[6] (P2[4] = V _{DD} /2, P2[6] = 0.5 V)	P2[4] + P2[6] - 0.073	P2[4] + P2[6] - 0.006	P2[4] + P2[6] + 0.056	V
		V _{AGND}	AGND	P2[4]	P2[4]	P2[4]	P2[4]	-
		V _{REFLO}	Ref Low	P2[4]-P2[6] (P2[4] = V _{DD} /2, P2[6] = 0.5 V)	P2[4] - P2[6] - 0.030	P2[4] - P2[6]	P2[4] - P2[6] + 0.032	V
0b010	RefPower = high Opamp bias = high	V _{REFHI}	Ref High	V _{DD}	V _{DD} - 0.102	V _{DD} - 0.003	V _{DD}	V
		V _{AGND}	AGND	V _{DD} /2	V _{DD} /2 - 0.040	V _{DD} /2 + 0.001	V _{DD} /2 + 0.039	V
		V _{REFLO}	Ref Low	V _{SS}	V _{SS}	V _{SS} + 0.005	V _{SS} + 0.020	V
	RefPower = high Opamp bias = low	V _{REFHI}	Ref High	V _{DD}	V _{DD} - 0.082	V _{DD} - 0.002	V _{DD}	V
		V _{AGND}	AGND	V _{DD} /2	V _{DD} /2 - 0.031	V _{DD} /2	V _{DD} /2 + 0.028	V
		V _{REFLO}	Ref Low	V _{SS}	V _{SS}	V _{SS} + 0.003	V _{SS} + 0.015	V
	RefPower = medium Opamp bias = high	V _{REFHI}	Ref High	V _{DD}	V _{DD} - 0.083	V _{DD} - 0.002	V _{DD}	V
		V _{AGND}	AGND	V _{DD} /2	V _{DD} /2 - 0.032	V _{DD} /2 - 0.001	V _{DD} /2 + 0.029	V
		V _{REFLO}	Ref Low	V _{SS}	V _{SS}	V _{SS} + 0.002	V _{SS} + 0.014	V
	RefPower = medium Opamp bias = low	V _{REFHI}	Ref High	V _{DD}	V _{DD} - 0.081	V _{DD} - 0.002	V _{DD}	V
		V _{AGND}	AGND	V _{DD} /2	V _{DD} /2 - 0.033	V _{DD} /2 - 0.001	V _{DD} /2 + 0.029	V
		V _{REFLO}	Ref Low	V _{SS}	V _{SS}	V _{SS} + 0.002	V _{SS} + 0.013	V
0b011	All power settings Not allowed at 3.3 V	-	-	-	-	-	-	-

Table 24. 3.3 V DC Analog Reference Specifications (continued)

Reference ARF_CR [5:3]	Reference Power Settings	Symbol	Reference	Description	Min	Typ	Max	Units
0b100	All power settings Not allowed at 3.3 V	–	–	–	–	–	–	–
0b101	RefPower = high Opamp bias = high	V _{REFHI}	Ref High	P2[4] + Bandgap (P2[4] = V _{DD} /2)	P2[4] + 1.211	P2[4] + 1.285	P2[4] + 1.348	V
		V _{AGND}	AGND	P2[4]	P2[4]	P2[4]	P2[4]	–
		V _{REFLO}	Ref Low	P2[4] – Bandgap (P2[4] = V _{DD} /2)	P2[4] – 1.354	P2[4] – 1.290	P2[4] – 1.197	V
	RefPower = high Opamp bias = low	V _{REFHI}	Ref High	P2[4] + Bandgap (P2[4] = V _{DD} /2)	P2[4] + 1.209	P2[4] + 1.289	P2[4] + 1.353	V
		V _{AGND}	AGND	P2[4]	P2[4]	P2[4]	P2[4]	–
		V _{REFLO}	Ref Low	P2[4] – Bandgap (P2[4] = V _{DD} /2)	P2[4] – 1.352	P2[4] – 1.294	P2[4] – 1.222	V
	RefPower = medium Opamp bias = high	V _{REFHI}	Ref High	P2[4] + Bandgap (P2[4] = V _{DD} /2)	P2[4] + 1.218	P2[4] + 1.291	P2[4] + 1.351	V
		V _{AGND}	AGND	P2[4]	P2[4]	P2[4]	P2[4]	–
		V _{REFLO}	Ref Low	P2[4] – Bandgap (P2[4] = V _{DD} /2)	P2[4] – 1.351	P2[4] – 1.296	P2[4] – 1.224	V
	RefPower = medium Opamp bias = low	V _{REFHI}	Ref High	P2[4] + Bandgap (P2[4] = V _{DD} /2)	P2[4] + 1.215	P2[4] + 1.292	P2[4] + 1.354	V
		V _{AGND}	AGND	P2[4]	P2[4]	P2[4]	P2[4]	–
		V _{REFLO}	Ref Low	P2[4] – Bandgap (P2[4] = V _{DD} /2)	P2[4] – 1.352	P2[4] – 1.297	P2[4] – 1.227	V
0b110	RefPower = high Opamp bias = high	V _{REFHI}	Ref High	2 × Bandgap	2.460	2.594	2.695	V
		V _{AGND}	AGND	Bandgap	1.257	1.302	1.335	V
		V _{REFLO}	Ref Low	V _{SS}	V _{SS}	V _{SS} + 0.01	V _{SS} + 0.029	V
	RefPower = high Opamp bias = low	V _{REFHI}	Ref High	2 × Bandgap	2.462	2.592	2.692	V
		V _{AGND}	AGND	Bandgap	1.256	1.301	1.332	V
		V _{REFLO}	Ref Low	V _{SS}	V _{SS}	V _{SS} + 0.005	V _{SS} + 0.017	V
	RefPower = medium Opamp bias = high	V _{REFHI}	Ref High	2 × Bandgap	2.473	2.593	2.682	V
		V _{AGND}	AGND	Bandgap	1.257	1.301	1.330	V
		V _{REFLO}	Ref Low	V _{SS}	V _{SS}	V _{SS} + 0.003	V _{SS} + 0.014	V
	RefPower = medium Opamp bias = low	V _{REFHI}	Ref High	2 × Bandgap	2.470	2.594	2.685	V
		V _{AGND}	AGND	Bandgap	1.256	1.300	1.332	V
		V _{REFLO}	Ref Low	V _{SS}	V _{SS}	V _{SS} + 0.002	V _{SS} + 0.012	V
0b111	All power settings Not allowed at 3.3 V	–	–	–	–	–	–	

Table 25. 2.7 V DC Analog Reference Specifications

Reference ARF_CR [5:3]	Reference Power Settings	Symbol	Reference	Description	Min	Typ	Max	Units
0b000	All power settings Not allowed at 2.7 V	–	–	–	–	–	–	–
0b001	RefPower = medium Opamp bias = high	V _{REFHI}	Ref High	P2[4]+P2[6] (P2[4] = V _{DD} /2, P2[6] = 0.5 V)	P2[4] + P2[6] – 0.739	P2[4] + P2[6] – 0.016	P2[4] + P2[6] + 0.759	V
		V _{AGND}	AGND	P2[4]	P2[4]	P2[4]	P2[4]	–
		V _{REFLO}	Ref Low	P2[4]–P2[6] (P2[4] = V _{DD} /2, P2[6] = 0.5 V)	P2[4] – P2[6] – 1.675	P2[4] – P2[6] + 0.013	P2[4] – P2[6] + 1.825	V
	RefPower = medium Opamp bias = low	V _{REFHI}	Ref High	P2[4]+P2[6] (P2[4] = V _{DD} /2, P2[6] = 0.5 V)	P2[4] + P2[6] – 0.098	P2[4] + P2[6] – 0.011	P2[4] + P2[6] + 0.067	V
		V _{AGND}	AGND	P2[4]	P2[4]	P2[4]	P2[4]	–
		V _{REFLO}	Ref Low	P2[4]–P2[6] (P2[4] = V _{DD} /2, P2[6] = 0.5 V)	P2[4] – P2[6] – 0.308	P2[4] – P2[6] + 0.004	P2[4] – P2[6] + 0.362	V
	RefPower = low Opamp bias = high	V _{REFHI}	Ref High	P2[4]+P2[6] (P2[4] = V _{DD} /2, P2[6] = 0.5 V)	P2[4] + P2[6] – 0.042	P2[4] + P2[6] – 0.005	P2[4] + P2[6] + 0.035	V
		V _{AGND}	AGND	P2[4]	P2[4]	P2[4]	P2[4]	–
		V _{REFLO}	Ref Low	P2[4]–P2[6] (P2[4] = V _{DD} /2, P2[6] = 0.5 V)	P2[4] – P2[6] – 0.030	P2[4] – P2[6]	P2[4] – P2[6] + 0.030	V
	RefPower = low Opamp bias = low	V _{REFHI}	Ref High	P2[4]+P2[6] (P2[4] = V _{DD} /2, P2[6] = 0.5 V)	P2[4] + P2[6] – 0.367	P2[4] + P2[6] – 0.005	P2[4] + P2[6] + 0.308	V
		V _{AGND}	AGND	P2[4]	P2[4]	P2[4]	P2[4]	–
		V _{REFLO}	Ref Low	P2[4]–P2[6] (P2[4] = V _{DD} /2, P2[6] = 0.5 V)	P2[4] – P2[6] – 0.345	P2[4] – P2[6]	P2[4] – P2[6] + 0.301	V
0b010	RefPower = high Opamp bias = high	V _{REFHI}	Ref High	V _{DD}	V _{DD} – 0.100	V _{DD} – 0.003	V _{DD}	V
		V _{AGND}	AGND	V _{DD} /2	V _{DD} /2 – 0.038	V _{DD} /2	V _{DD} /2 + 0.036	V
		V _{REFLO}	Ref Low	V _{SS}	V _{SS}	V _{SS} + 0.005	V _{SS} + 0.016	V
	RefPower = high Opamp bias = low	V _{REFHI}	Ref High	V _{DD}	V _{DD} – 0.065	V _{DD} – 0.002	V _{DD}	V
		V _{AGND}	AGND	V _{DD} /2	V _{DD} /2 – 0.025	V _{DD} /2	V _{DD} /2 + 0.023	V
		V _{REFLO}	Ref Low	V _{SS}	V _{SS}	V _{SS} + 0.003	V _{SS} + 0.012	V
	RefPower = medium Opamp bias = high	V _{REFHI}	Ref High	V _{DD}	V _{DD} – 0.054	V _{DD} – 0.002	V _{DD}	V
		V _{AGND}	AGND	V _{DD} /2	V _{DD} /2 – 0.024	V _{DD} /2 – 0.001	V _{DD} /2 + 0.020	V
		V _{REFLO}	Ref Low	V _{SS}	V _{SS}	V _{SS} + 0.002	V _{SS} + 0.012	V
	RefPower = medium Opamp bias = low	V _{REFHI}	Ref High	V _{DD}	V _{DD} – 0.042	V _{DD} – 0.002	V _{DD}	V
		V _{AGND}	AGND	V _{DD} /2	V _{DD} /2 – 0.027	V _{DD} /2 – 0.001	V _{DD} /2 + 0.022	V
		V _{REFLO}	Ref Low	V _{SS}	V _{SS}	V _{SS} + 0.001	V _{SS} + 0.010	V
	RefPower = low Opamp bias = high	V _{REFHI}	Ref High	V _{DD}	V _{DD} – 0.042	V _{DD} – 0.002	V _{DD}	V
		V _{AGND}	AGND	V _{DD} /2	V _{DD} /2 – 0.028	V _{DD} /2 – 0.001	V _{DD} /2 + 0.023	V
		V _{REFLO}	Ref Low	V _{SS}	V _{SS}	V _{SS} + 0.001	V _{SS} + 0.010	V
	RefPower = low Opamp bias = low	V _{REFHI}	Ref High	V _{DD}	V _{DD} – 0.036	V _{DD} – 0.002	V _{DD}	V
		V _{AGND}	AGND	V _{DD} /2	V _{DD} /2 – 0.184	V _{DD} /2 – 0.001	V _{DD} /2 + 0.159	V
		V _{REFLO}	Ref Low	V _{SS}	V _{SS}	V _{SS} + 0.001	V _{SS} + 0.009	V



Table 25. 2.7 V DC Analog Reference Specifications (continued)

Reference ARF_CR [5:3]	Reference Power Settings	Symbol	Reference	Description	Min	Typ	Max	Units
0b011	All power settings Not allowed at 2.7 V	–	–	–	–	–	–	–
0b100	All power settings Not allowed at 2.7 V	–	–	–	–	–	–	–
0b101	All power settings Not allowed at 2.7 V	–	–	–	–	–	–	–
0b110	RefPower = high Opamp bias = high	V _{REFHI}	Ref High	2 × Bandgap	Not allowed	Not allowed	Not allowed	V
		V _{AGND}	AGND	Bandgap	1.160	1.302	1.340	V
		V _{REFLO}	Ref Low	V _{SS}	V _{SS}	V _{SS} + 0.007	V _{SS} + 0.025	V
	RefPower = high Opamp bias = low	V _{REFHI}	Ref High	2 × Bandgap	Not allowed	Not allowed	Not allowed	V
		V _{AGND}	AGND	Bandgap	1.160	1.301	1.338	V
		V _{REFLO}	Ref Low	V _{SS}	V _{SS}	V _{SS} + 0.004	V _{SS} + 0.017	V
	RefPower = medium Opamp bias = high	V _{REFHI}	Ref High	2 × Bandgap	Not allowed	Not allowed	Not allowed	V
		V _{AGND}	AGND	Bandgap	1.160	1.301	1.338	V
		V _{REFLO}	Ref Low	V _{SS}	V _{SS}	V _{SS} + 0.003	V _{SS} + 0.013	V
	RefPower = medium Opamp bias = low	V _{REFHI}	Ref High	2 × Bandgap	Not allowed	Not allowed	Not allowed	V
		V _{AGND}	AGND	Bandgap	1.160	1.300	1.337	V
		V _{REFLO}	Ref Low	V _{SS}	V _{SS}	V _{SS} + 0.002	V _{SS} + 0.011	V
	RefPower = low Opamp bias = high	V _{REFHI}	Ref High	2 × Bandgap	Not allowed	Not allowed	Not allowed	V
		V _{AGND}	AGND	Bandgap	1.252	1.300	1.339	V
		V _{REFLO}	Ref Low	V _{SS}	V _{SS}	V _{SS} + 0.002	V _{SS} + 0.011	V
	RefPower = low Opamp bias = low	V _{REFHI}	Ref High	2 × Bandgap	Not allowed	Not allowed	Not allowed	V
		V _{AGND}	AGND	Bandgap	1.252	1.300	1.339	V
		V _{REFLO}	Ref Low	V _{SS}	V _{SS}	V _{SS} + 0.001	V _{SS} + 0.01	V
0b111	All power settings Not allowed at 2.7 V	–	–	–	–	–	–	

DC Analog PSoC Block Specifications

Table 25 lists the guaranteed maximum and minimum specifications for the voltage and temperature ranges: 4.75 V to 5.25 V and –40 °C ≤ T_A ≤ 85 °C, 3.0 V to 3.6 V and –40 °C ≤ T_A ≤ 85 °C, or 2.4 V to 3.0 V and –40 °C ≤ T_A ≤ 85 °C, respectively. Typical parameters are measured at 5 V, 3.3 V, and 2.7 V at 25 °C and are for design guidance only.

Table 26. DC Analog PSoC Block Specifications

Symbol	Description	Min	Typ	Max	Units	Notes
R _{CT}	Resistor unit value (continuous time)	–	12.2	–	kΩ	
C _{SC}	Capacitor unit value (switched capacitor)	–	80	–	fF	

DC POR, SMP, and LVD Specifications

Table 26 lists the guaranteed maximum and minimum specifications for the voltage and temperature ranges: 4.75 V to 5.25 V and $-40\text{ }^{\circ}\text{C} \leq T_A \leq 85\text{ }^{\circ}\text{C}$, 3.0 V to 3.6 V and $-40\text{ }^{\circ}\text{C} \leq T_A \leq 85\text{ }^{\circ}\text{C}$, or 2.4 V to 3.0 V and $-40\text{ }^{\circ}\text{C} \leq T_A \leq 85\text{ }^{\circ}\text{C}$, respectively. Typical parameters are measured at 5 V, 3.3 V, and 2.7 V at 25 °C and are for design guidance only.

Note The bits PORLEV and VM in the following table refer to bits in the VLT_CR register. See the [PSoC Programmable System-on-Chip Technical Reference Manual](#) for more information on the VLT_CR register.

Table 27. DC POR and LVD Specifications

Symbol	Description	Min	Typ	Max	Units	Notes
V_{PPOR0}	V_{DD} value for PPOR trip PORLEV[1:0] = 00b	–	2.36	2.40	V	V_{DD} must be greater than or equal to 2.5 V during startup, reset from the XRES pin, or reset from watchdog.
V_{PPOR1}	PORLEV[1:0] = 01b		2.82	2.95	V	
V_{PPOR2}	PORLEV[1:0] = 10b		4.55	4.70	V	
V_{LVD0}	V_{DD} value for LVD trip VM[2:0] = 000b	2.40	2.45	2.51 ^[12]	V	
V_{LVD1}	VM[2:0] = 001b	2.85	2.92	2.99 ^[13]	V	
V_{LVD2}	VM[2:0] = 010b	2.95	3.02	3.09	V	
V_{LVD3}	VM[2:0] = 011b	3.06	3.13	3.20	V	
V_{LVD4}	VM[2:0] = 100b	4.37	4.48	4.55	V	
V_{LVD5}	VM[2:0] = 101b	4.50	4.64	4.75	V	
V_{LVD6}	VM[2:0] = 110b	4.62	4.73	4.83	V	
V_{LVD7}	VM[2:0] = 111b	4.71	4.81	4.95	V	
V_{PUMP0}	V_{DD} value for SMP trip VM[2:0] = 000b	2.50	2.55	2.62 ^[14]	V	
V_{PUMP1}	VM[2:0] = 001b	2.96	3.02	3.09	V	
V_{PUMP2}	VM[2:0] = 010b	3.03	3.10	3.16	V	
V_{PUMP3}	VM[2:0] = 011b	3.18	3.25	3.32 ^[15]	V	
V_{PUMP4}	VM[2:0] = 100b	4.54	4.64	4.74	V	
V_{PUMP5}	VM[2:0] = 101b	4.62	4.73	4.83	V	
V_{PUMP6}	VM[2:0] = 110b	4.71	4.82	4.92	V	
V_{PUMP7}	VM[2:0] = 111b	4.89	5.00	5.12	V	

Notes

12. Always greater than 50 mV above V_{PPOR} (PORLEV=00) for falling supply.
13. Always greater than 50 mV above V_{PPOR} (PORLEV=01) for falling supply.
14. Always greater than 50 mV above V_{LVD0} .
15. Always greater than 50 mV above V_{LVD3} .



DC Programming Specifications

Table 28 lists the guaranteed maximum and minimum specifications for the voltage and temperature ranges: 4.75 V to 5.25 V and $-40\text{ }^{\circ}\text{C} \leq T_A \leq 85\text{ }^{\circ}\text{C}$, 3.0 V to 3.6 V and $-40\text{ }^{\circ}\text{C} \leq T_A \leq 85\text{ }^{\circ}\text{C}$, or 2.4 V to 3.0 V and $-40\text{ }^{\circ}\text{C} \leq T_A \leq 85\text{ }^{\circ}\text{C}$, respectively. Typical parameters are measured at 5 V, 3.3 V, and 2.7 V at 25 °C and are for design guidance only.

Table 28. DC Programming Specifications

Symbol	Description	Min	Typ	Max	Units	Notes
V _{DDP}	V _{DD} for programming and erase	4.5	5	5.5	V	This specification applies to the functional requirements of external programmer tools
V _{DDL}	Low V _{DD} for verify	2.4	2.5	2.6	V	This specification applies to the functional requirements of external programmer tools
V _{DDH}	High V _{DD} for verify	5.1	5.2	5.3	V	This specification applies to the functional requirements of external programmer tools
V _{DDIWRITE}	Supply voltage for flash write operation	2.7		5.25	V	This specification applies to this device when it is executing internal flash writes
I _{DDP}	Supply current during programming or verify	–	5	25	mA	
V _{ILP}	Input low voltage during programming or verify	–	–	0.8	V	
V _{IHP}	Input high voltage during programming or verify	2.1	–	–	V	
I _{ILP}	Input current when applying V _{ILP} to P1[0] or P1[1] during programming or verify	–	–	0.2	mA	Driving internal pull-down resistor
I _{IHP}	Input current when applying V _{IHP} to P1[0] or P1[1] during programming or verify	–	–	1.5	mA	Driving internal pull-down resistor
V _{OLV}	Output low voltage during programming or verify	–	–	V _{SS} + 0.75	V	
V _{OHV}	Output high voltage during programming or verify	V _{DD} – 1.0	–	V _{DD}	V	
Flash _{ENPB}	Flash endurance (per block)	50,000 ^[16]	–	–	–	Erase/write cycles per block
Flash _{ENT}	Flash endurance (total) ^[17]	1,800,000	–	–	–	Erase/write cycles
Flash _{DR}	Flash data retention	10	–	–	Years	

DC I²C Specifications

Table 29 lists the guaranteed maximum and minimum specifications for the voltage and temperature ranges: 4.75 V to 5.25 V and $-40\text{ }^{\circ}\text{C} \leq T_A \leq 85\text{ }^{\circ}\text{C}$, 3.0 V to 3.6 V and $-40\text{ }^{\circ}\text{C} \leq T_A \leq 85\text{ }^{\circ}\text{C}$, or 2.4 V to 3.0 V and $-40\text{ }^{\circ}\text{C} \leq T_A \leq 85\text{ }^{\circ}\text{C}$, respectively. Typical parameters are measured at 5 V, 3.3 V, and 2.7 V at 25 °C and are for design guidance only.

Table 29. DC I²C Specifications^[18]

Symbol	Description	Min	Typ	Max	Units	Notes
V _{IL2C}	Input low level	–	–	0.3 × V _{DD}	V	2.4 V ≤ V _{DD} ≤ 3.6 V
		–	–	0.25 × V _{DD}	V	4.75 V ≤ V _{DD} ≤ 5.25 V
V _{IH2C}	Input high level	0.7 × V _{DD}	–	–	V	2.4 V ≤ V _{DD} ≤ 5.25 V

Notes

- The 50,000 cycle flash endurance per block is only guaranteed if the flash is operating within one voltage range. Voltage ranges are 2.4 V to 3.0 V, 3.0 V to 3.6 V, and 4.75 V to 5.25 V.
- A maximum of 36 × 50,000 block endurance cycles is allowed. This may be balanced between operations on 36 × 1 blocks of 50,000 maximum cycles each, 36 × 2 blocks of 25,000 maximum cycles each, or 36 × 4 blocks of 12,500 maximum cycles each (to limit the total number of cycles to 36 × 50,000 and that no single block ever sees more than 50,000 cycles).
For the full industrial range, the user must employ a temperature sensor user module (FlashTemp) and feed the result to the temperature argument before writing. Refer to the Flash APIs application note [Design Aids – Reading and Writing PSoC® Flash – AN2015](#) for more information.
- All GPIOs meet the DC GPIO V_{IL} and V_{IH} specifications found in the DC GPIO Specifications sections. The I²C GPIO pins also meet the above specs.



AC Electrical Characteristics

AC Chip-Level Specifications

These tables list the guaranteed maximum and minimum specifications for the voltage and temperature ranges: 4.75 V to 5.25 V and $-40\text{ }^{\circ}\text{C} \leq T_A \leq 85\text{ }^{\circ}\text{C}$, 3.0 V to 3.6 V and $-40\text{ }^{\circ}\text{C} \leq T_A \leq 85\text{ }^{\circ}\text{C}$, or 2.4 V to 3.0 V and $-40\text{ }^{\circ}\text{C} \leq T_A \leq 85\text{ }^{\circ}\text{C}$, respectively. Typical parameters are measured at 5 V, 3.3 V, and 2.7 V at 25 °C and are for design guidance only.

Table 30. 5 V and 3.3 V AC Chip-Level Specifications

Symbol	Description	Min	Typ	Max	Units	Notes
F _{IMO24} ^[19]	Internal main oscillator (IMO) frequency for 24 MHz	22.8	24	25.2 ^[20,21]	MHz	Trimmed for 5 V or 3.3 V operation using factory trim values. See Figure 10 on page 18. SLIMO mode = 0.
F _{IMO6}	IMO frequency for 6 MHz	5.5	6	6.5 ^[20,21]	MHz	Trimmed for 5 V or 3.3 V operation using factory trim values. See Figure 10 on page 18. SLIMO mode = 1.
F _{CPU1}	CPU frequency (5 V nominal)	0.937	24	24.6 ^[20]	MHz	SLIMO mode = 0.
F _{CPU2}	CPU frequency (3.3 V nominal)	0.937	12	12.3 ^[21]	MHz	SLIMO mode = 0.
F _{48M}	Digital PSoC block frequency	0	48	49.2 ^[20,22]	MHz	Refer to the AC Digital Block Specifications.
F _{24M}	Digital PSoC block frequency	0	24	24.6 ^[22]	MHz	
F _{32K1}	ILO frequency	15	32	64	kHz	
F _{32K2}	External crystal oscillator	–	32.768	–	kHz	Accuracy is capacitor and crystal dependent. 50% duty cycle.
F _{32K_U}	ILO untrimmed frequency	5	–	100	kHz	After a reset and before the M8C starts to run, the ILO is not trimmed. See the System Resets section of the PSoC Technical Reference Manual for details on timing this
F _{PLL}	PLL frequency	–	23.986	–	MHz	Is a multiple (x732) of crystal frequency.
T _{PLLSLEW}	PLL lock time	0.5	–	10	ms	
T _{PLLSLEWSLOW}	PLL lock time for low gain setting	0.5	–	50	ms	
T _{OS}	External crystal oscillator startup to 1%	–	1700	2620	ms	
T _{OSACC}	External crystal oscillator startup to 100 ppm	–	2800	3800	ms	The crystal oscillator frequency is within 100 ppm of its final value by the end of the T _{OSACC} period. Correct operation assumes a properly loaded 1 μW maximum drive level 32.768 kHz crystal. 3.0 V ≤ V _{DD} ≤ 5.5 V, –40 °C ≤ T _A ≤ 85 °C.
t _{XRST}	External reset pulse width	10	–	–	μs	

Notes

19. **Errata:** When the device is operated within 0 °C to 70 °C, the frequency tolerance is reduced to ±2.5%, but if operated at extreme temperature (below 0 °C or above 70 °C), frequency tolerance deviates from ±2.5% to ±5%. For more information, see "Errata" on page 67.
20. 4.75 V < V_{DD} < 5.25 V.
21. 3.0 V < V_{DD} < 3.6 V. See application note [Adjusting PSoC® Trims for 3.3 V and 2.7 V Operation – AN2012](#) for information on trimming for operation at 3.3 V.
22. See the individual user module datasheets for information on maximum frequencies for user modules.
23. Refer to Cypress Jitter Specifications application note, [Understanding Datasheet Jitter Specifications for Cypress Timing Products – AN5054](#) for more information.



Table 30. 5 V and 3.3 V AC Chip-Level Specifications (continued)

Symbol	Description	Min	Typ	Max	Units	Notes
DC24M	24 MHz duty cycle	40	50	60	%	
DC _{ILO}	ILO duty cycle	20	50	80	%	
Step24M	24 MHz trim step size	–	50	–	kHz	
F _{out48M}	48 MHz output frequency	46.8	48.0	49.2 ^[24, 25]	MHz	Trimmed. Using factory trim values.
F _{MAX}	Maximum frequency of signal on row input or row output.	–	–	12.3	MHz	
SR _{POWER_UP}	Power supply slew rate	–	–	250	V/ms	V _{DD} slew rate during power-up.
t _{POWERUP}	Time from end of POR to CPU executing code	–	16	100	ms	Power-up from 0 V. See the System Resets section of the PSoC Technical Reference Manual.
t _{jit_IMO} ^[26]	24 MHz IMO cycle-to-cycle jitter (RMS)	–	200	700	ps	N = 32
	24 MHz IMO long term N cycle-to-cycle jitter (RMS)	–	300	900	ps	
	24 MHz IMO period jitter (RMS)	–	100	400	ps	
t _{jit_PLL} ^[26]	24 MHz IMO cycle-to-cycle jitter (RMS)	–	200	800	ps	N = 32
	24 MHz IMO long term N cycle-to-cycle jitter (RMS)	–	300	1200		
	24 MHz IMO period jitter (RMS)	–	100	700		

Notes

24. 4.75 V < V_{DD} < 5.25 V.

25. 3.0 V < V_{DD} < 3.6 V. See application note [Adjusting PSoC® Trims for 3.3 V and 2.7 V Operation – AN2012](#) for information on trimming for operation at 3.3 V.

26. Refer to Cypress Jitter Specifications application note, [Understanding Datasheet Jitter Specifications for Cypress Timing Products – AN5054](#) for more information.



Table 31. 2.7 V AC Chip-Level Specifications

Symbol	Description	Min	Typ	Max	Units	Notes
F _{IMO12}	IMO frequency for 12 MHz	11.5	12	12.7 ^[27, 28]	MHz	Trimmed for 2.7 V operation using factory trim values. See Figure 10 on page 18 . SLIMO mode = 1.
F _{IMO6}	IMO frequency for 6 MHz	5.5	6	6.5 ^[27, 28]	MHz	Trimmed for 2.7 V operation using factory trim values. See Figure 10 on page 18 . SLIMO mode = 1.
F _{CPU1}	CPU frequency (2.7 V nominal)	0.937	3	3.15 ^[27]	MHz	SLIMO mode = 0.
F _{BLK27}	Digital PSoC block frequency (2.7 V nominal)	0	12	12.7 ^[27, 28]	MHz	Refer to the AC Digital Block Specifications.
F _{32K1}	ILO frequency	8	32	96	kHz	
F _{32K_U}	ILO untrimmed frequency	5	–	100	kHz	After a reset and before the M8C starts to run, the ILO is not trimmed. See the System Resets section of the PSoC Technical Reference Manual for details on timing this
t _{XRST}	External reset pulse width	10	–	–	µs	
DC _{12M}	12 MHz duty cycle	40	50	60	%	
DC _{ILO}	ILO duty cycle	20	50	80	%	
F _{MAX}	Maximum frequency of signal on row input or row output.	–	–	12.7	MHz	
SR _{POWER_UP}	Power supply slew rate	–	–	250	V/ms	V _{DD} slew rate during power-up.
t _{POWERUP}	Time from end of POR to CPU executing code	–	16	100	ms	Power-up from 0 V. See the System Resets section of the PSoC Technical Reference Manual .
t _{jit_IMO} ^[29]	12 MHz IMO cycle-to-cycle jitter (RMS)	–	400	1000	ps	N = 32
	12 MHz IMO long term N cycle-to-cycle jitter (RMS)	–	600	1300	ps	
	12 MHz IMO period jitter (RMS)	–	100	500	ps	
t _{jit_PLL} ^[29]	12 MHz IMO cycle-to-cycle jitter (RMS)	–	400	1000	ps	N = 32
	12 MHz IMO long term N cycle-to-cycle jitter (RMS)	–	700	1300		
	12 MHz IMO period jitter (RMS)	–	300	500		

Notes

27. 2.4 V < V_{DD} < 3.0 V.

28. Refer to application note [Adjusting PSoC® Trims for 3.3 V and 2.7 V Operation – AN2012](#) for information on trimming for operation at 3.3 V.

29. Refer to Cypress Jitter Specifications application note, [Understanding Datasheet Jitter Specifications for Cypress Timing Products – AN5054](#) for more information.

Figure 12. PLL Lock Timing Diagram

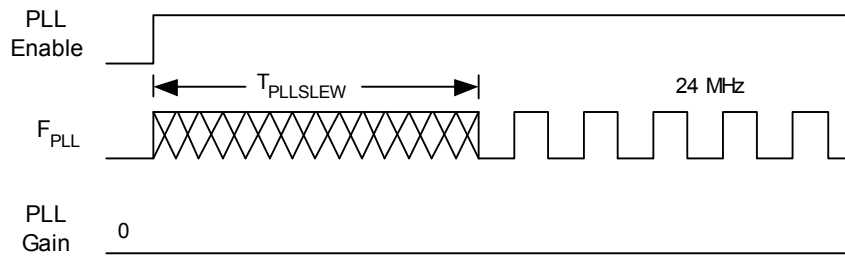

Figure 13. PLL Lock for Low Gain Setting Timing Diagram

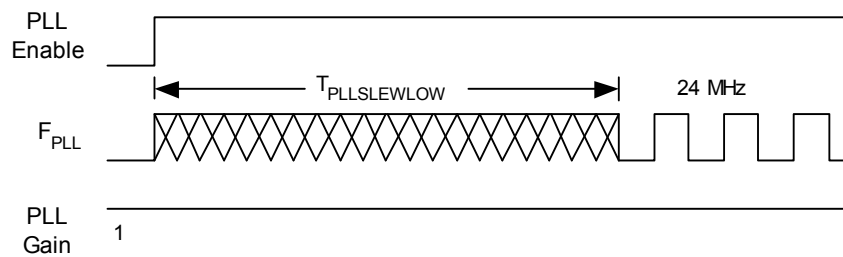
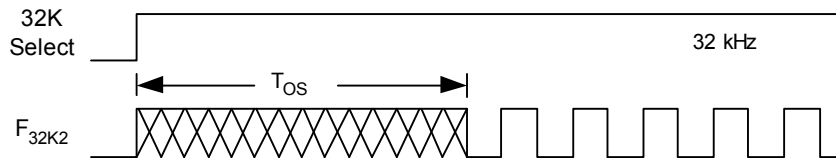

Figure 14. External Crystal Oscillator Startup Timing Diagram



AC GPIO Specifications

These tables list the guaranteed maximum and minimum specifications for the voltage and temperature ranges: 4.75 V to 5.25 V and $-40\text{ }^{\circ}\text{C} \leq T_A \leq 85\text{ }^{\circ}\text{C}$, 3.0 V to 3.6 V and $-40\text{ }^{\circ}\text{C} \leq T_A \leq 85\text{ }^{\circ}\text{C}$, or 2.4 V to 3.0 V and $-40\text{ }^{\circ}\text{C} \leq T_A \leq 85\text{ }^{\circ}\text{C}$, respectively. Typical parameters are measured at 5 V, 3.3 V, and 2.7 V at 25 °C and are for design guidance only.

Table 32. 5 V and 3.3 V AC GPIO Specifications

Symbol	Description	Min	Typ	Max	Units	Notes
F_{GPIO}	GPIO operating frequency	0	–	12	MHz	Normal Strong Mode
t_{RiseF}	Rise time, normal strong mode, Clload = 50 pF	3	–	18	ns	$V_{\text{DD}} = 4.5$ to 5.25 V, 10% to 90%
t_{FallF}	Fall time, normal strong mode, Clload = 50 pF	2	–	18	ns	$V_{\text{DD}} = 4.5$ to 5.25 V, 10% to 90%
t_{RiseS}	Rise time, slow strong mode, Clload = 50 pF	10	27	–	ns	$V_{\text{DD}} = 3$ to 5.25 V, 10% to 90%
t_{FallS}	Fall time, slow strong mode, Clload = 50 pF	10	22	–	ns	$V_{\text{DD}} = 3$ to 5.25 V, 10% to 90%

Table 33. 2.7 V AC GPIO Specifications

Symbol	Description	Min	Typ	Max	Units	Notes
F_{GPIO}	GPIO operating frequency	0	–	3	MHz	Normal strong mode
t_{RiseF}	Rise time, normal strong mode, Clload = 50 pF	6	–	50	ns	$V_{\text{DD}} = 2.4$ to 3.0 V, 10% to 90%
t_{FallF}	Fall time, normal strong mode, Clload = 50 pF	6	–	50	ns	$V_{\text{DD}} = 2.4$ to 3.0 V, 10% to 90%
t_{RiseS}	Rise time, slow strong mode, Clload = 50 pF	18	40	120	ns	$V_{\text{DD}} = 2.4$ to 3.0 V, 10% to 90%
t_{FallS}	Fall time, slow strong mode, Clload = 50 pF	18	40	120	ns	$V_{\text{DD}} = 2.4$ to 3.0 V, 10% to 90%

Figure 15. GPIO Timing Diagram

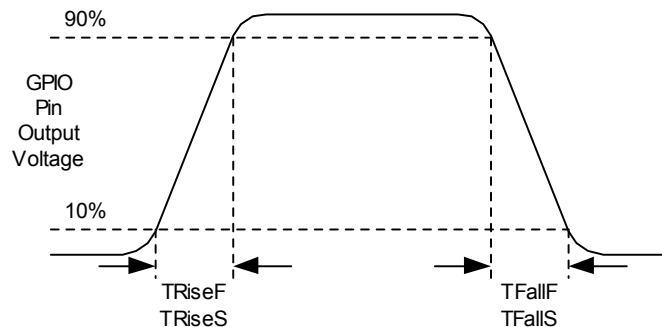

AC Operational Amplifier Specifications

The following tables list the guaranteed maximum and minimum specifications for the voltage and temperature ranges: 4.75 V to 5.25 V and $-40\text{ }^{\circ}\text{C} \leq T_A \leq 85\text{ }^{\circ}\text{C}$, 3.0 V to 3.6 V and $-40\text{ }^{\circ}\text{C} \leq T_A \leq 85\text{ }^{\circ}\text{C}$, or 2.4 V to 3.0 V and $-40\text{ }^{\circ}\text{C} \leq T_A \leq 85\text{ }^{\circ}\text{C}$, respectively. Typical parameters are measured at 5 V, 3.3 V, and 2.7 V at 25 °C and are for design guidance only.

Settling times, slew rates, and gain bandwidth are based on the analog continuous time PSoC block.

Power = high and Opamp bias = high is not supported at 3.3 V and 2.7 V.

Table 34. 5 V AC Operational Amplifier Specifications

Symbol	Description	Min	Typ	Max	Units
t_{ROA}	Rising settling time from 80% of ΔV to 0.1% of ΔV (10 pF load, unity gain)				
	Power = low, Opamp bias = low	–	–	3.9	μs
	Power = medium, Opamp bias = high	–	–	0.72	μs
t_{SOA}	Falling settling time from 20% of ΔV to 0.1% of ΔV (10 pF load, unity gain)				
	Power = low, Opamp bias = low	–	–	5.9	μs
	Power = medium, Opamp bias = high	–	–	0.92	μs
SR_{ROA}	Rising slew rate (20% to 80%) (10 pF load, unity gain)				
	Power = low, Opamp bias = low	0.15	–	–	V/ μs
	Power = medium, Opamp bias = high	1.7	–	–	V/ μs
SR_{FOA}	Falling slew rate (20% to 80%) (10 pF load, unity gain)				
	Power = low, Opamp bias = low	0.01	–	–	V/ μs
	Power = medium, Opamp bias = high	0.5	–	–	V/ μs
BW_{OA}	Gain bandwidth product				
	Power = low, Opamp bias = low	0.75	–	–	MHz
	Power = medium, Opamp bias = high	3.1	–	–	MHz
E_{NOA}	Noise at 1 kHz (Power = medium, Opamp bias = high)	–	100	–	nV/rt-Hz

Table 35. 3.3 V AC Operational Amplifier Specifications

Symbol	Description	Min	Typ	Max	Units
t_{ROA}	Rising settling time from 80% of ΔV to 0.1% of ΔV (10 pF load, unity gain)				
	Power = low, Opamp bias = low	–	–	3.92	μs
t_{SOA}	Falling settling time from 20% of ΔV to 0.1% of ΔV (10 pF load, unity gain)				
	Power = low, Opamp bias = low	–	–	5.41	μs
SR_{ROA}	Rising slew rate (20% to 80%) (10 pF load, unity gain)				
	Power = low, Opamp bias = low	0.31	–	–	V/ μs
SR_{FOA}	Falling slew rate (20% to 80%) (10 pF load, unity gain)				
	Power = low, Opamp bias = low	0.24	–	–	V/ μs
BW_{OA}	Gain bandwidth product				
	Power = low, Opamp bias = low	0.67	–	–	MHz
E_{NOA}	Noise at 1 kHz (Power = medium, Opamp bias = high)	–	100	–	nV/rt-Hz

Table 36. 2.7 V AC Operational Amplifier Specifications

Symbol	Description	Min	Typ	Max	Units
t_{ROA}	Rising settling time from 80% of ΔV to 0.1% of ΔV (10 pF load, unity gain) Power = low, Opamp bias = low Power = medium, Opamp bias = high	–	–	3.92	μs
		–	–	0.72	μs
t_{SOA}	Falling settling time from 20% of ΔV to 0.1% of ΔV (10 pF load, unity gain) Power = low, Opamp bias = low Power = medium, Opamp bias = high	–	–	5.41	μs
		–	–	0.72	μs
SR_{ROA}	Rising slew rate (20% to 80%) (10 pF load, unity gain) Power = low, Opamp bias = low Power = medium, Opamp bias = high	0.31	–	–	V/ μs
		2.7	–	–	V/ μs
SR_{FOA}	Falling slew rate (20% to 80%) (10 pF load, unity gain) Power = low, Opamp bias = low Power = medium, Opamp bias = high	0.24	–	–	V/ μs
		1.8	–	–	V/ μs
BW_{OA}	Gain bandwidth product Power = low, Opamp bias = low Power = medium, Opamp bias = high	0.67	–	–	MHz
		2.8	–	–	MHz
E_{NOA}	Noise at 1 kHz (Power = medium, Opamp bias = high)	–	100	–	nV/rt-Hz

When bypassed by a capacitor on P2[4], the noise of the analog ground signal distributed to each block is reduced by a factor of up to 5 (14 dB). This is at frequencies above the corner frequency defined by the on-chip 8.1 K resistance and the external capacitor.

Figure 16. Typical AGND Noise with P2[4] Bypass

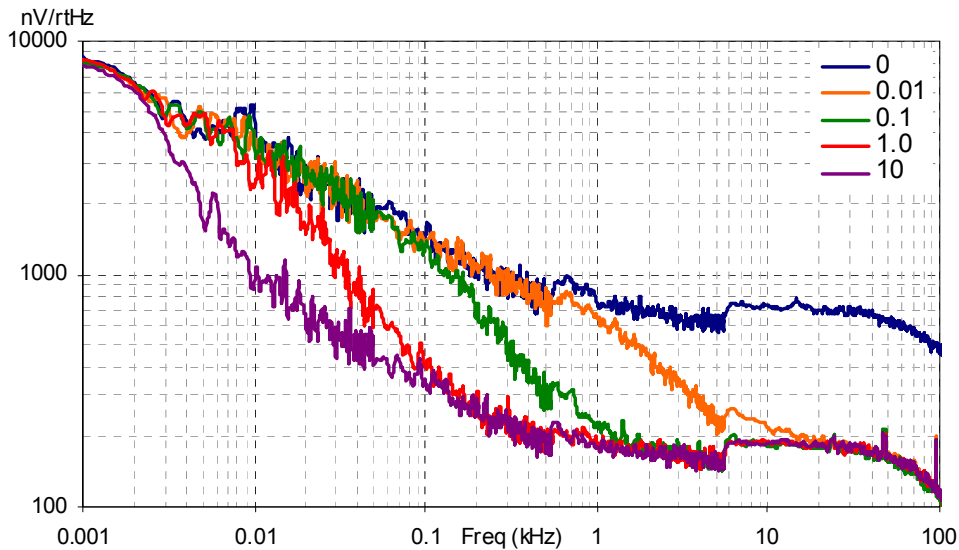

At low frequencies, the opamp noise is proportional to $1/f$, power independent, and determined by device geometry. At high frequencies, increased power level reduces the noise spectrum level.

Figure 17. Typical Opamp Noise

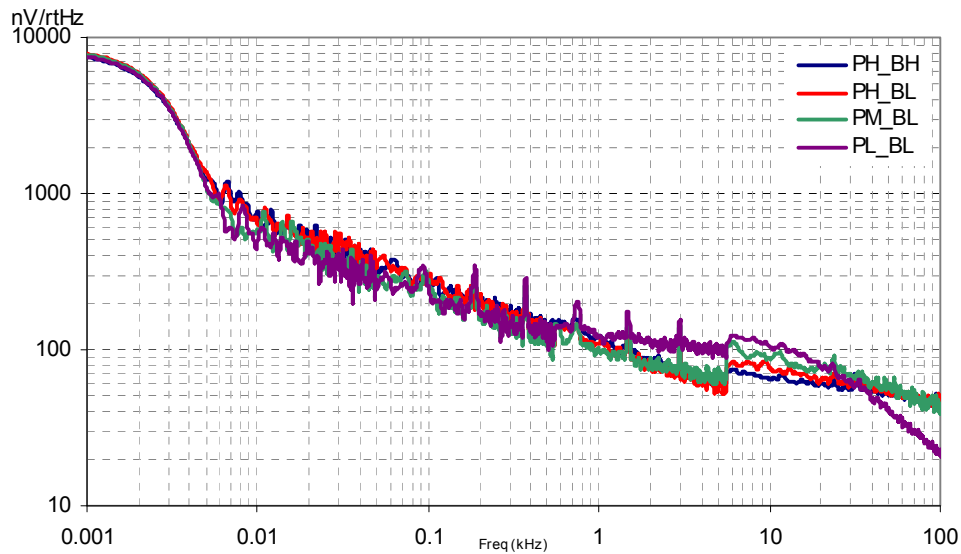

AC Low Power Comparator Specifications

Table 37 lists the guaranteed maximum and minimum specifications for the voltage and temperature ranges: 4.75 V to 5.25 V and $-40\text{ }^{\circ}\text{C} \leq T_A \leq 85\text{ }^{\circ}\text{C}$, 3.0 V to 3.6 V and $-40\text{ }^{\circ}\text{C} \leq T_A \leq 85\text{ }^{\circ}\text{C}$, or 2.4 V to 3.0 V and $-40\text{ }^{\circ}\text{C} \leq T_A \leq 85\text{ }^{\circ}\text{C}$, respectively. Typical parameters are measured at 5 V at 25 °C and are for design guidance only.

Table 37. AC Low Power Comparator Specifications

Symbol	Description	Min	Typ	Max	Units	Notes
t_{RLPC}	LPC response time	–	–	50	μs	$\geq 50\text{ mV}$ overdrive comparator reference set within V_{REFLPC}

AC Digital Block Specifications

The following tables list the guaranteed maximum and minimum specifications for the voltage and temperature ranges: 4.75 V to 5.25 V and $-40\text{ }^{\circ}\text{C} \leq T_A \leq 85\text{ }^{\circ}\text{C}$, 3.0 V to 3.6 V and $-40\text{ }^{\circ}\text{C} \leq T_A \leq 85\text{ }^{\circ}\text{C}$, or 2.4 V to 3.0 V and $-40\text{ }^{\circ}\text{C} \leq T_A \leq 85\text{ }^{\circ}\text{C}$, respectively. Typical parameters are measured at 5 V, 3.3 V, and 2.7 V at 25 °C and are for design guidance only.

Table 38. 5 V and 3.3 V AC Digital Block Specifications

Function	Description	Min	Typ	Max	Unit	Notes
All functions	Block input clock frequency					
	$V_{DD} \geq 4.75\text{ V}$	–	–	50.4	MHz	
	$V_{DD} < 4.75\text{ V}$	–	–	25.2	MHz	
Timer	Input clock frequency					
	No capture, $V_{DD} \geq 4.75\text{ V}$	–	–	50.4	MHz	
	No capture, $V_{DD} < 4.75\text{ V}$	–	–	25.2	MHz	
	With capture	–	–	25.2	MHz	
	Capture pulse width	50 ^[30]	–	–	ns	
Counter	Input clock frequency					
	No enable input, $V_{DD} \geq 4.75\text{ V}$	–	–	50.4	MHz	
	No enable input, $V_{DD} < 4.75\text{ V}$	–	–	25.2	MHz	
	With enable input	–	–	25.2	MHz	
	Enable input pulse width	50 ^[30]	–	–	ns	
Dead Band	Kill pulse width					
	Asynchronous restart mode	20	–	–	ns	
	Synchronous restart mode	50 ^[30]	–	–	ns	
	Disable mode	50 ^[30]	–	–	ns	
	Input clock frequency					
	$V_{DD} \geq 4.75\text{ V}$	–	–	50.4	MHz	
	$V_{DD} < 4.75\text{ V}$	–	–	25.2	MHz	
CRCPRS (PRS Mode)	Input clock frequency					
	$V_{DD} \geq 4.75\text{ V}$	–	–	50.4	MHz	
	$V_{DD} < 4.75\text{ V}$	–	–	25.2	MHz	
CRCPRS (CRC Mode)	Input clock frequency	–	–	25.2	MHz	
SPI M	Input clock frequency	–	–	8.2	MHz	The SPI serial clock (SCLK) frequency is equal to the input clock frequency divided by 2.
SPIS	Input clock (SCLK) frequency	–	–	4.1	MHz	The input clock is the SPI SCLK in SPIS mode.
	Width of SS_negated between transmissions	50 ^[30]	–	–	ns	
Transmitter	Input clock frequency					The baud rate is equal to the input clock frequency divided by 8.
	$V_{DD} \geq 4.75\text{ V}$, 2 stop bits	–	–	50.4	MHz	
	$V_{DD} \geq 4.75\text{ V}$, 1 stop bit	–	–	25.2	MHz	
	$V_{DD} < 4.75\text{ V}$	–	–	25.2	MHz	
Receiver	Input clock frequency					The baud rate is equal to the input clock frequency divided by 8.
	$V_{DD} \geq 4.75\text{ V}$, 2 stop bits	–	–	50.4	MHz	
	$V_{DD} \geq 4.75\text{ V}$, 1 stop bit	–	–	25.2	MHz	
	$V_{DD} < 4.75\text{ V}$	–	–	25.2	MHz	

Note

30. 50 ns minimum input pulse width is based on the input synchronizers running at 24 MHz (42 ns nominal period).

Table 39. 2.7 V AC Digital Block Specifications

Function	Description	Min	Typ	Max	Units	Notes
All Functions	Block input clock frequency	–	–	12.7	MHz	2.4 V < V _{DD} < 3.0 V
Timer	Capture pulse width	100 ^[31]	–	–	ns	
	Input clock frequency, with or without capture	–	–	12.7	MHz	
Counter	Enable Input Pulse Width	100 ^[31]	–	–	ns	
	Input clock frequency, no enable input	–	–	12.7	MHz	
	Input clock frequency, enable input	–	–	12.7	MHz	
Dead Band	Kill pulse width:					
	Asynchronous restart mode	20	–	–	ns	
	Synchronous restart mode	100 ^[31]	–	–	ns	
	Disable mode	100 ^[31]	–	–	ns	
	Input clock frequency	–	–	12.7	MHz	
CRCPRS (PRS Mode)	Input clock frequency	–	–	12.7	MHz	
CRCPRS (CRC Mode)	Input clock frequency	–	–	12.7	MHz	
SPIM	Input clock frequency	–	–	6.35	MHz	The SPI serial clock (SCLK) frequency is equal to the input clock frequency divided by 2.
SPIS	Input clock frequency	–	–	4.23	MHz	
	Width of SS_ Negated between transmissions	100 ^[31]	–	–	ns	
Transmitter	Input clock frequency	–	–	12.7	MHz	The baud rate is equal to the input clock frequency divided by 8.
Receiver	Input clock frequency	–	–	12.7	MHz	The baud rate is equal to the input clock frequency divided by 8.

Note

31. 50 ns minimum input pulse width is based on the input synchronizers running at 12 MHz (84 ns nominal period).

AC Analog Output Buffer Specifications

The following tables list the guaranteed maximum and minimum specifications for the voltage and temperature ranges: 4.75 V to 5.25 V and $-40\text{ }^{\circ}\text{C} \leq T_A \leq 85\text{ }^{\circ}\text{C}$, 3.0 V to 3.6 V and $-40\text{ }^{\circ}\text{C} \leq T_A \leq 85\text{ }^{\circ}\text{C}$, or 2.4 V to 3.0 V and $-40\text{ }^{\circ}\text{C} \leq T_A \leq 85\text{ }^{\circ}\text{C}$, respectively. Typical parameters are measured at 5 V, 3.3 V, and 2.7 V at 25 °C and are for design guidance only.

Table 40. 5 V AC Analog Output Buffer Specifications

Symbol	Description	Min	Typ	Max	Units
t_{ROB}	Rising settling time to 0.1%, 1 V Step, 100 pF load Power = low Power = high	–	–	2.5	μs
		–	–	2.5	μs
t_{SOB}	Falling settling time to 0.1%, 1 V Step, 100 pF load Power = low Power = high	–	–	2.2	μs
		–	–	2.2	μs
SR_{ROB}	Rising slew rate (20% to 80%), 1 V Step, 100 pF load Power = low Power = high	0.65	–	–	V/ μs
		0.65	–	–	V/ μs
SR_{FOB}	Falling slew rate (80% to 20%), 1 V Step, 100 pF load Power = low Power = high	0.65	–	–	V/ μs
		0.65	–	–	V/ μs
BW_{OB}	Small signal bandwidth, 20mV _{pp} , 3dB BW, 100 pF load Power = low Power = high	0.8	–	–	MHz
		0.8	–	–	MHz
BW_{OB}	Large signal bandwidth, 1V _{pp} , 3dB BW, 100 pF load Power = low Power = high	300	–	–	kHz
		300	–	–	kHz

Table 41. 3.3 V AC Analog Output Buffer Specifications

Symbol	Description	Min	Typ	Max	Units
t_{ROB}	Rising settling time to 0.1%, 1 V Step, 100 pF load Power = low Power = high	–	–	3.8	μs
		–	–	3.8	μs
t_{SOB}	Falling settling time to 0.1%, 1 V Step, 100 pF load Power = low Power = high	–	–	2.6	μs
		–	–	2.6	μs
SR_{ROB}	Rising slew rate (20% to 80%), 1 V Step, 100 pF load Power = low Power = high	0.5	–	–	V/ μs
		0.5	–	–	V/ μs
SR_{FOB}	Falling slew rate (80% to 20%), 1 V Step, 100 pF load Power = low Power = high	0.5	–	–	V/ μs
		0.5	–	–	V/ μs
BW_{OB}	Small signal bandwidth, 20mV _{pp} , 3dB BW, 100 pF load Power = low Power = high	0.7	–	–	MHz
		0.7	–	–	MHz
BW_{OB}	Large signal bandwidth, 1V _{pp} , 3dB BW, 100 pF load Power = low Power = high	200	–	–	kHz
		200	–	–	kHz

Table 42. 2.7 V AC Analog Output Buffer Specifications

Symbol	Description	Min	Typ	Max	Units
t _{ROB}	Rising settling time to 0.1%, 1 V Step, 100 pF load Power = low Power = high	–	–	4	μs
		–	–	4	μs
t _{SOB}	Falling settling time to 0.1%, 1 V Step, 100 pF load Power = low Power = high	–	–	3	μs
		–	–	3	μs
SR _{ROB}	Rising slew rate (20% to 80%), 1 V Step, 100 pF load Power = low Power = high	0.4	–	–	V/μs
		0.4	–	–	V/μs
SR _{FOB}	Falling slew rate (80% to 20%), 1 V Step, 100 pF load Power = low Power = high	0.4	–	–	V/μs
		0.4	–	–	V/μs
BW _{OB}	Small signal bandwidth, 20 mV _{pp} , 3dB BW, 100 pF load Power = low Power = high	0.6	–	–	MHz
		0.6	–	–	MHz
BW _{OB}	Large signal bandwidth, 1 V _{pp} , 3dB BW, 100 pF load Power = low Power = high	180	–	–	kHz
		180	–	–	kHz

AC External Clock Specifications

The following tables list the guaranteed maximum and minimum specifications for the voltage and temperature ranges: 4.75 V to 5.25 V and $-40\text{ }^{\circ}\text{C} \leq T_A \leq 85\text{ }^{\circ}\text{C}$, 3.0 V to 3.6 V and $-40\text{ }^{\circ}\text{C} \leq T_A \leq 85\text{ }^{\circ}\text{C}$, or 2.4 V to 3.0 V and $-40\text{ }^{\circ}\text{C} \leq T_A \leq 85\text{ }^{\circ}\text{C}$, respectively. Typical parameters are measured at 5 V, 3.3 V, and 2.7 V at 25 °C and are for design guidance only.

Table 43. 5 V AC External Clock Specifications

Symbol	Description	Min	Typ	Max	Units
F _{OSCEXT}	Frequency	0.093	–	24.6	MHz
–	High period	20.6	–	5300	ns
–	Low period	20.6	–	–	ns
–	Power-up IMO to switch	150	–	–	μs

Table 44. 3.3 V AC External Clock Specifications

Symbol	Description	Min	Typ	Max	Units
F _{OSCEXT}	Frequency with CPU clock divide by 1 ^[32]	0.093	–	12.3	MHz
F _{OSCEXT}	Frequency with CPU clock divide by 2 or greater ^[33]	0.186	–	24.6	MHz
–	High period with CPU clock divide by 1	41.7	–	5300	ns
–	Low period with CPU clock divide by 1	41.7	–	–	ns
–	Power-up IMO to switch	150	–	–	μs

Notes

32. Maximum CPU frequency is 12 MHz at 3.3 V. With the CPU clock divider set to 1, the external clock must adhere to the maximum frequency and duty cycle requirements.

33. If the frequency of the external clock is greater than 12 MHz, the CPU clock divider must be set to 2 or greater. In this case, the CPU clock divider ensures that the fifty percent duty cycle requirement is met.

Table 45. 2.7 V AC External Clock Specifications

Symbol	Description	Min	Typ	Max	Units	Notes
F _{OSCEXT}	Frequency with CPU clock divide by 1 ^[34]	0.093	–	12.3	MHz	
F _{OSCEXT}	Frequency with CPU clock divide by 2 or greater ^[35]	0.186	–	12.3	MHz	
–	High period with CPU clock divide by 1	41.7	–	5300	ns	
–	Low period with CPU clock divide by 1	41.7	–	–	ns	
–	Power-up IMO to switch	150	–	–	µs	

AC Programming Specifications

Table 46 lists the guaranteed maximum and minimum specifications for the voltage and temperature ranges: 4.75 V to 5.25 V and $-40\text{ °C} \leq T_A \leq 85\text{ °C}$, 3.0 V to 3.6 V and $-40\text{ °C} \leq T_A \leq 85\text{ °C}$, or 2.4 V to 3.0 V and $-40\text{ °C} \leq T_A \leq 85\text{ °C}$, respectively. Typical parameters are measured at 5 V, 3.3 V, and 2.7 V at 25 °C and are for design guidance only.

Table 46. AC Programming Specifications

Symbol	Description	Min	Typ	Max	Units	Notes
t _{RCLK}	Rise time of SCLK	1	–	20	ns	
t _{FCLK}	Fall time of SCLK	1	–	20	ns	
t _{SSCLK}	Data setup time to falling edge of SCLK	40	–	–	ns	
t _{HSCLK}	Data hold time from falling edge of SCLK	40	–	–	ns	
F _{SCLK}	Frequency of SCLK	0	–	8	MHz	
t _{ERASEB}	Flash erase time (block)	–	20	–	ms	
t _{WRITE}	Flash block write time	–	80	–	ms	
t _{DSCLK}	Data out delay from falling edge of SCLK	–	–	45	ns	V _{DD} > 3.6
t _{DSCLK3}	Data out delay from falling edge of SCLK	–	–	50	ns	3.0 ≤ V _{DD} ≤ 3.6
t _{DSCLK2}	Data out delay from falling edge of SCLK	–	–	70	ns	2.4 ≤ V _{DD} ≤ 3.0
t _{ERASEALL}	Flash erase time (Bulk)	–	20	–	ms	Erase all blocks and protection fields at once
t _{PROGRAM_HOT}	Flash block erase + flash block write time	–	–	200 ^[36]	ms	0 °C ≤ T _j ≤ 100 °C
t _{PROGRAM_COLD}	Flash block erase + flash block write time	–	–	400 ^[36]	ms	-40 °C ≤ T _j ≤ 0 °C

Notes

34. Maximum CPU frequency is 12 MHz at 3.3 V. With the CPU clock divider set to 1, the external clock must adhere to the maximum frequency and duty cycle requirements.
35. If the frequency of the external clock is greater than 12 MHz, the CPU clock divider must be set to 2 or greater. In this case, the CPU clock divider ensures that the fifty percent duty cycle requirement is met.
36. For the full industrial range, you must employ a temperature sensor user module (FlashTemp) and feed the result to the temperature argument before writing. Refer to the Flash APIs application note [Design Aids – Reading and Writing PSoC® Flash – AN2015](#) for more information.

AC I²C Specifications

The following tables list the guaranteed maximum and minimum specifications for the voltage and temperature ranges: 4.75 V to 5.25 V and $-40\text{ }^{\circ}\text{C} \leq T_A \leq 85\text{ }^{\circ}\text{C}$, 3.0 V to 3.6 V and $-40\text{ }^{\circ}\text{C} \leq T_A \leq 85\text{ }^{\circ}\text{C}$, or 2.4 V to 3.0 V and $-40\text{ }^{\circ}\text{C} \leq T_A \leq 85\text{ }^{\circ}\text{C}$, respectively. Typical parameters are measured at 5 V, 3.3 V, and 2.7 V at 25 °C and are for design guidance only.

Table 47. AC Characteristics of the I²C SDA and SCL Pins for $V_{DD} > 3.0\text{ V}$

Symbol	Description	Standard-Mode		Fast-Mode		Units
		Min	Max	Min	Max	
$F_{SCL I2C}$	SCL clock frequency	0	100	0	400	kHz
$t_{HDSTA I2C}$	Hold time (repeated) start condition. After this period, the first clock pulse is generated	4.0	–	0.6	–	μs
$t_{LOW I2C}$	Low period of the SCL clock	4.7	–	1.3	–	μs
$t_{HIGH I2C}$	High period of the SCL clock	4.0	–	0.6	–	μs
$t_{SUSTA I2C}$	Setup time for a repeated start condition	4.7	–	0.6	–	μs
$t_{HDDAT I2C}$	Data hold time	0	–	0	–	μs
$t_{SUDAT I2C}$	Data setup time	250	–	100 ^[37]	–	ns
$t_{SUSTOI2C}$	Setup time for stop condition	4.0	–	0.6	–	μs
t_{BUFI2C}	Bus free time between a stop and start condition	4.7	–	1.3	–	μs
t_{SPI2C}	Pulse width of spikes are suppressed by the input filter	–	–	0	50	ns

Table 48. AC Characteristics of the I²C SDA and SCL Pins for $V_{DD} < 3.0\text{ V}$ (Fast Mode Not Supported)

Symbol	Description	Standard-Mode		Fast-Mode		Units
		Min	Max	Min	Max	
$F_{SCL I2C}$	SCL clock frequency	0	100	–	–	kHz
$t_{HDSTA I2C}$	Hold time (repeated) start condition. After this period, the first clock pulse is generated	4.0	–	–	–	μs
$t_{LOW I2C}$	Low period of the SCL clock	4.7	–	–	–	μs
$t_{HIGH I2C}$	High period of the SCL clock	4.0	–	–	–	μs
$t_{SUSTA I2C}$	Setup time for a repeated start condition	4.7	–	–	–	μs
$t_{HDDAT I2C}$	Data hold time	0	–	–	–	μs
$t_{SUDAT I2C}$	Data setup time	250	–	–	–	ns
$t_{SUSTOI2C}$	Setup time for stop condition	4.0	–	–	–	μs
t_{BUFI2C}	Bus free time between a stop and start condition	4.7	–	–	–	μs
t_{SPI2C}	Pulse width of spikes are suppressed by the input filter	–	–	–	–	ns

Figure 18. Definition for Timing for Fast-/Standard-Mode on the I²C Bus

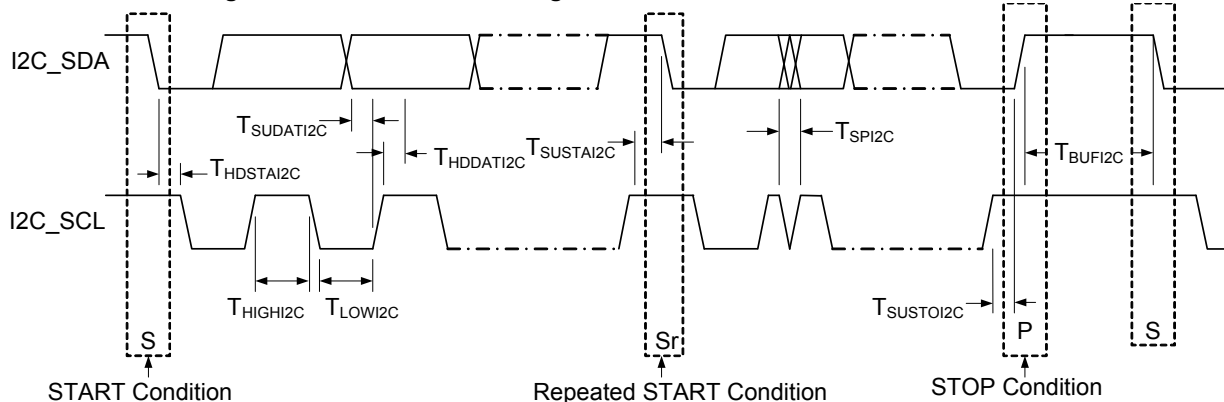

Note

37. A fast-mode I²C-bus device can be used in a Standard-Mode I²C-bus system, but the requirement $t_{SUDAT} \geq 250\text{ ns}$ must then be met. This is automatically the case if the device does not stretch the LOW period of the SCL signal. If such device does stretch the LOW period of the SCL signal, it must output the next data bit to the SDA line $t_{\text{max}} + t_{SUDAT} = 1000 + 250 = 1250\text{ ns}$ (according to the Standard-Mode I²C-bus specification) before the SCL line is released.

Packaging Information

This section illustrates the packaging specifications for the CY8C24x23A PSoC device, along with the thermal impedances for each package and the typical package capacitance on crystal pins.

Important Note Emulation tools may require a larger area on the target PCB than the chip's footprint. For a detailed description of the emulation tools' dimensions, see the emulator pod drawings at <http://www.cypress.com/design/MR10161>.

Packaging Dimensions

Figure 19. 8-Pin PDIP (300 Mils)

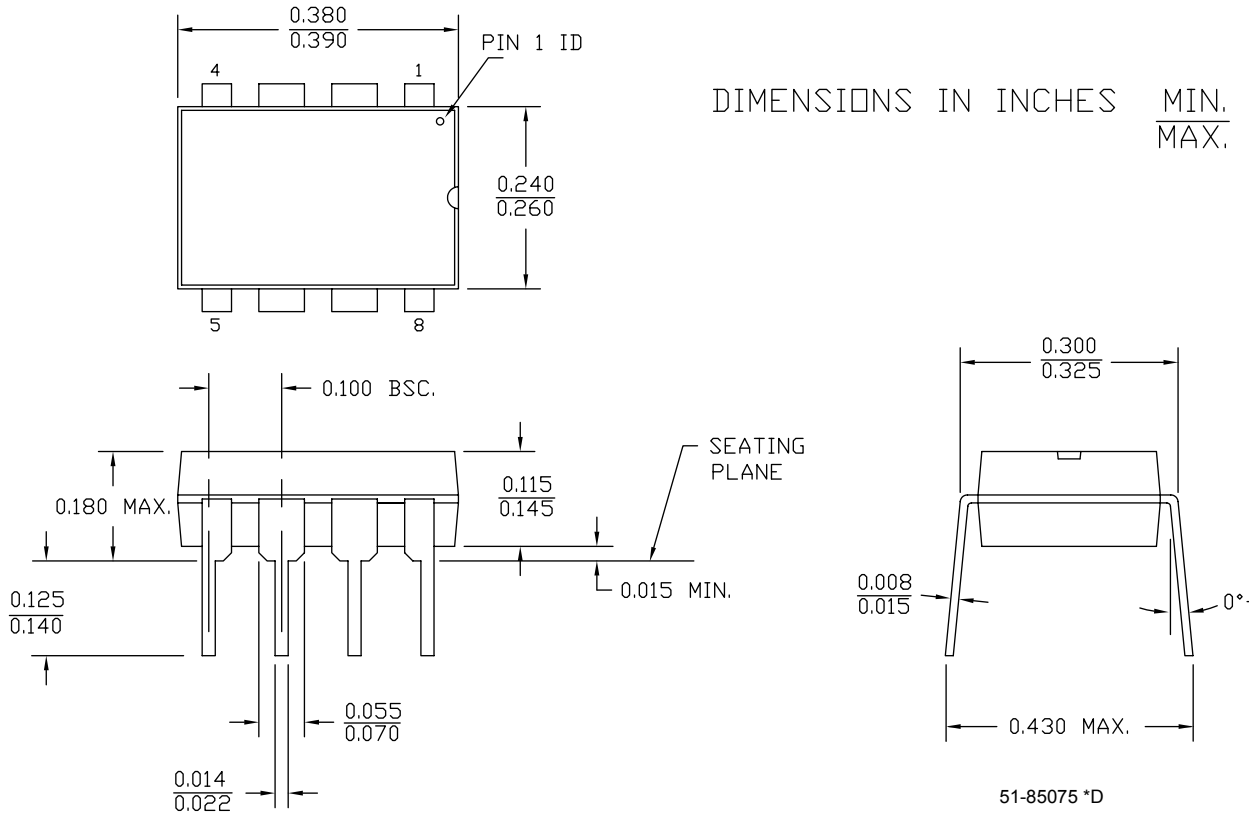

Figure 20. 8-Pin SOIC (150 Mils)

1. DIMENSIONS IN INCHES[MM] MIN. MAX.
2. PIN 1 ID IS OPTIONAL, ROUND ON SINGLE LEADFRAME RECTANGULAR ON MATRIX LEADFRAME
3. REFERENCE JEDEC MS-012
4. PACKAGE WEIGHT 0.07gms

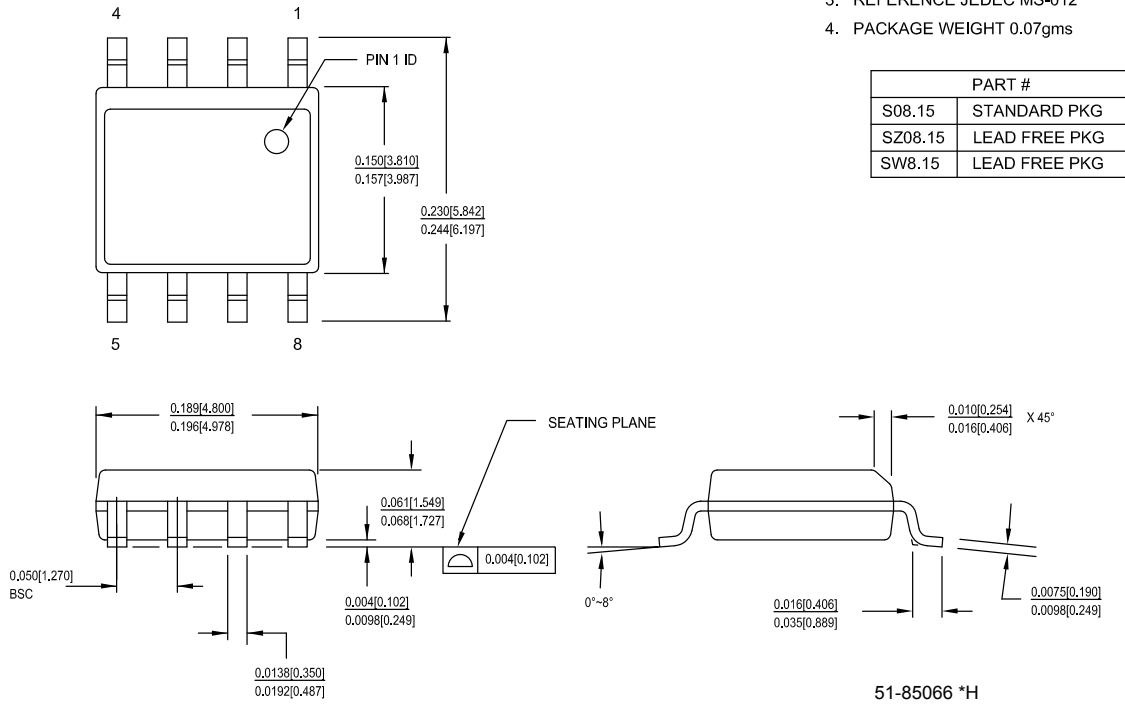

Figure 21. 20-Pin Molded DIP (300 Mils)

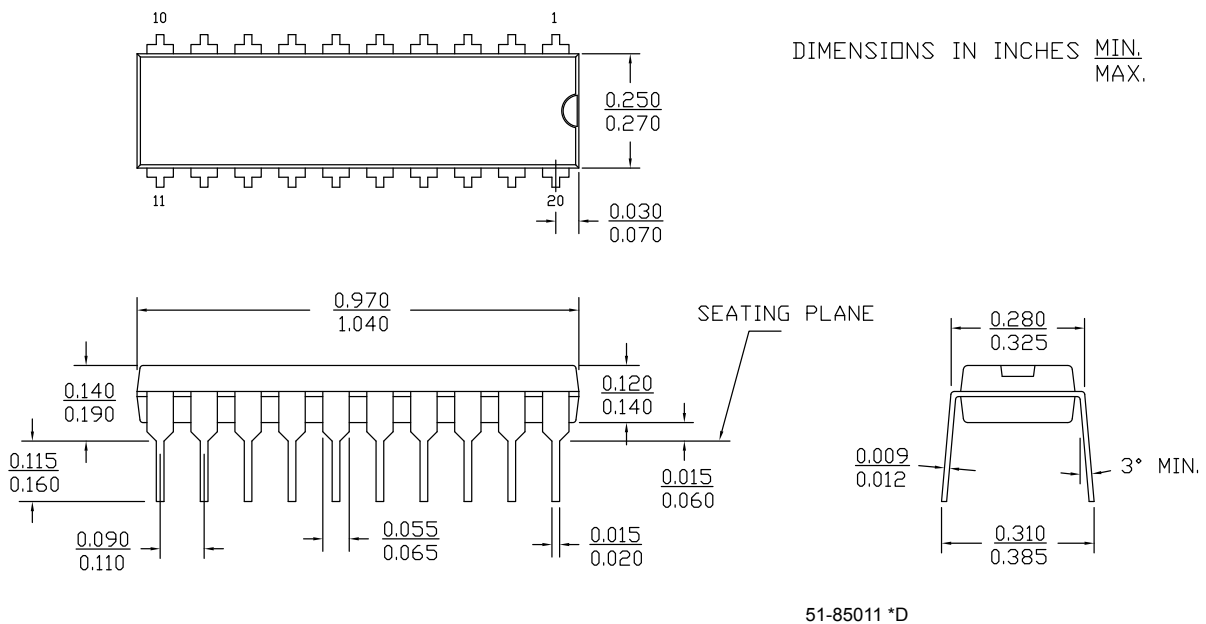

Figure 22. 20-Pin SSOP (210 Mils)

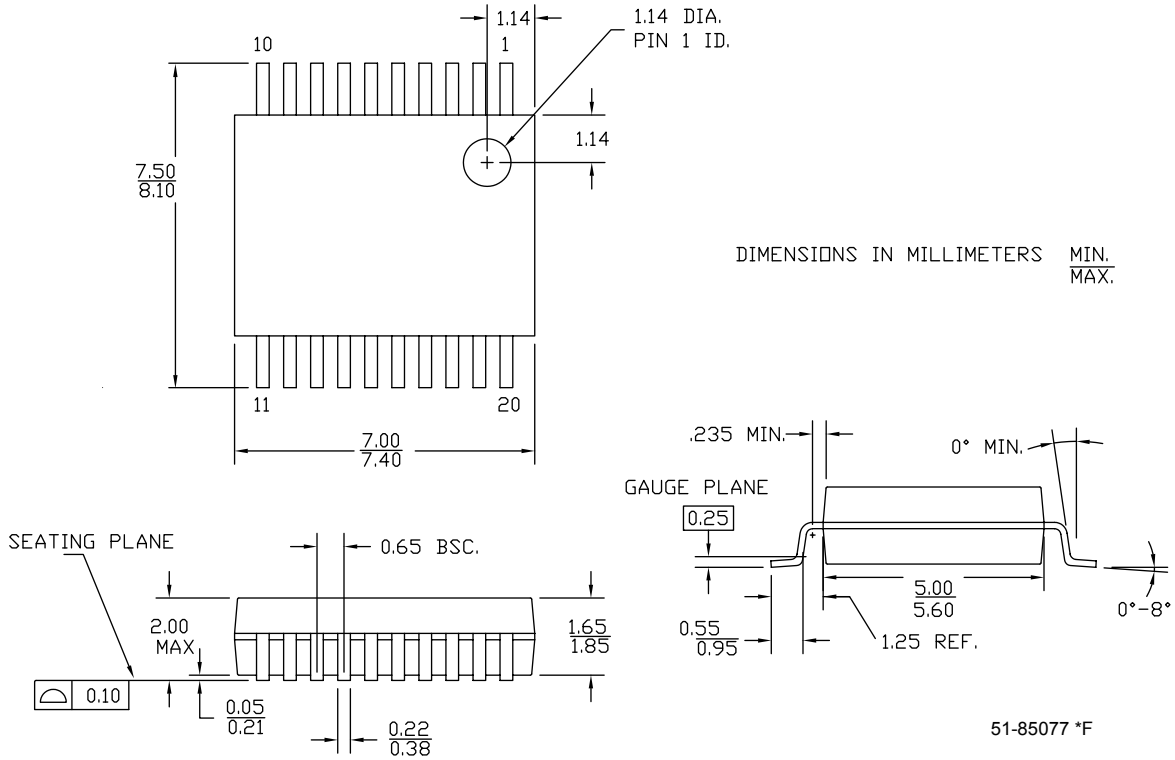

Figure 23. 20-Pin Molded SOIC (300 Mils)

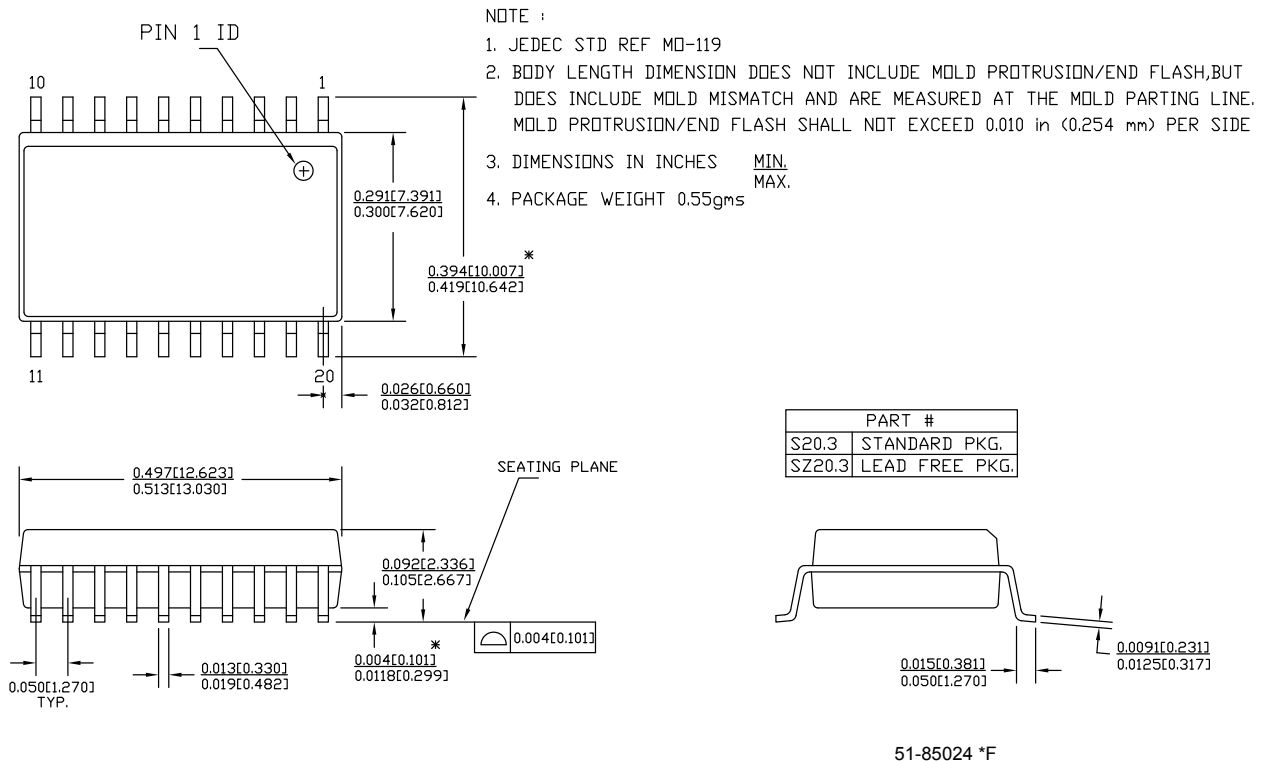

Figure 24. 28-Pin Molded DIP (300 Mils)

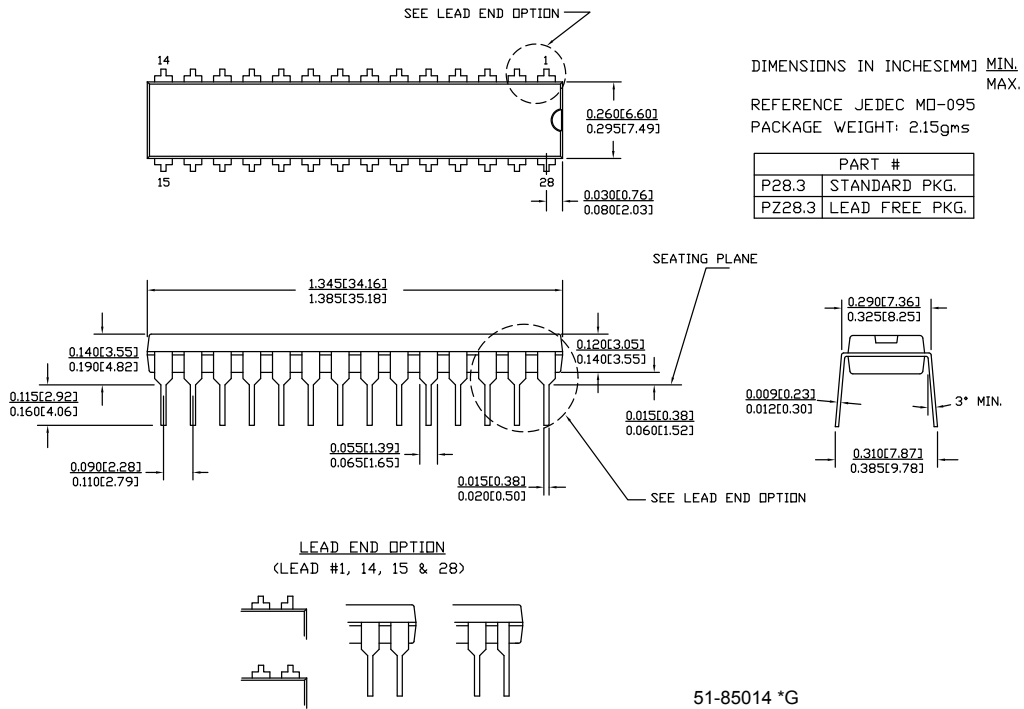

Figure 25. 28-Pin SSOP (210 Mils)

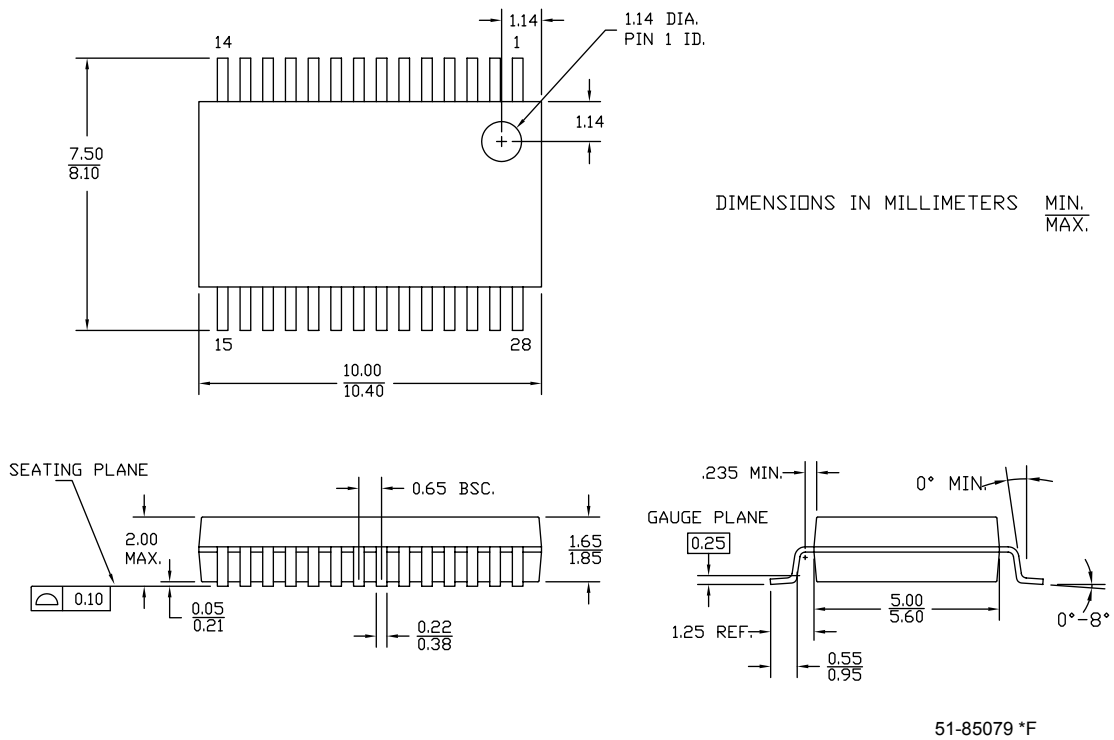
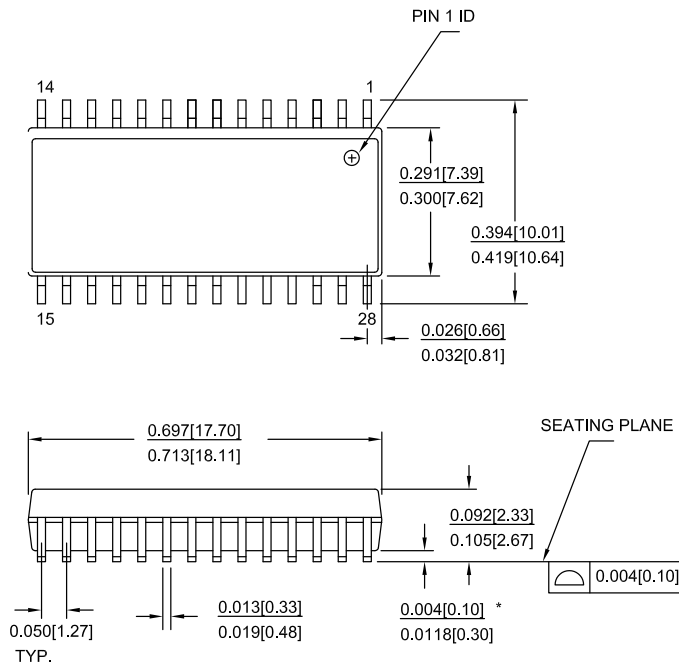

Figure 26. 28-Pin SOIC (300 Mils)

NOTE :

1. JEDEC STD REF MO-119
2. BODY LENGTH DIMENSION DOES NOT INCLUDE MOLD PROTRUSION/END FLASH, BUT DOES INCLUDE MOLD MISMATCH AND ARE MEASURED AT THE MOLD PARTING LINE. MOLD PROTRUSION/END FLASH SHALL NOT EXCEED 0.010 in (0.254 mm) PER SIDE
3. DIMENSIONS IN INCHES MIN.
MAX.



PART #	
S28.3	STANDARD PKG.
SZ28.3	LEAD FREE PKG.
SX28.3	LEAD FREE PKG.

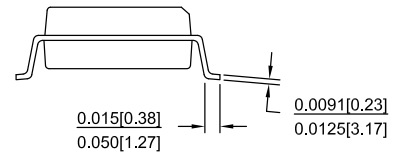

51-85026 *H

Figure 27. 32-Pin QFN (Sawn) Package

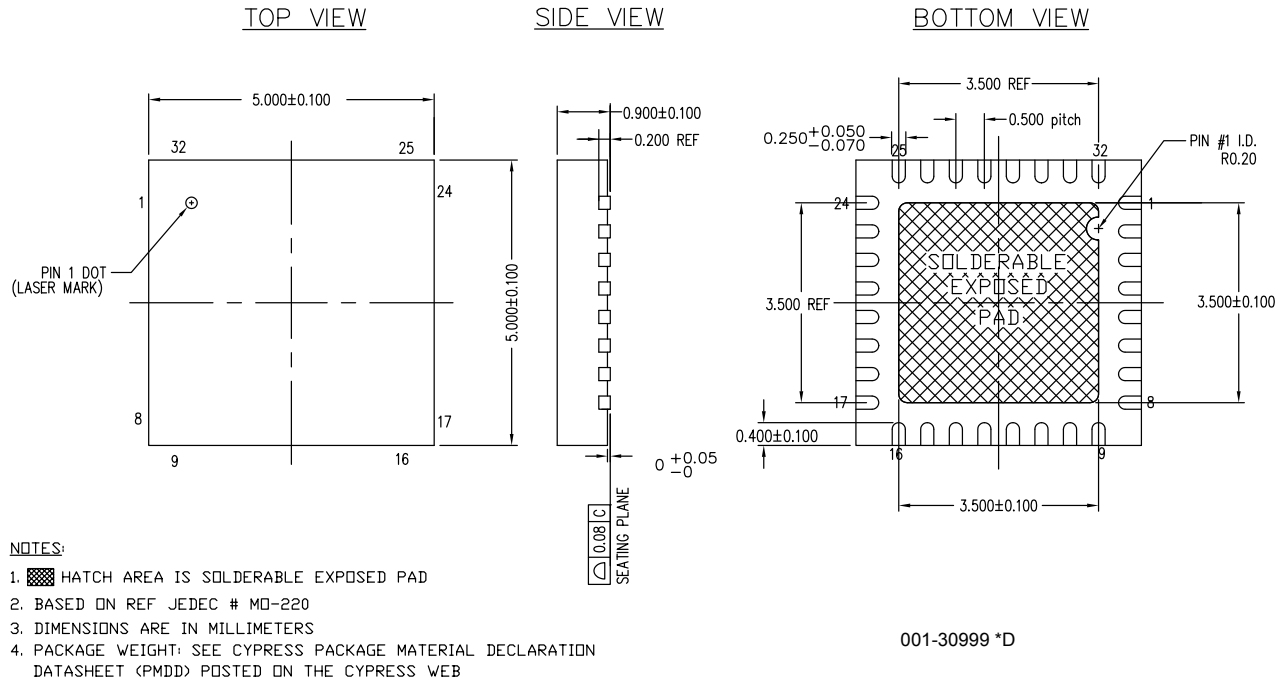

Important Note For information on the preferred dimensions for mounting QFN packages, see the application note, *Application Notes for Surface Mount Assembly of Amkor's MicroLeadFrame (MLF) Packages* available at <http://www.amkor.com>.

Figure 28. 56-Pin SSOP (300 Mils)

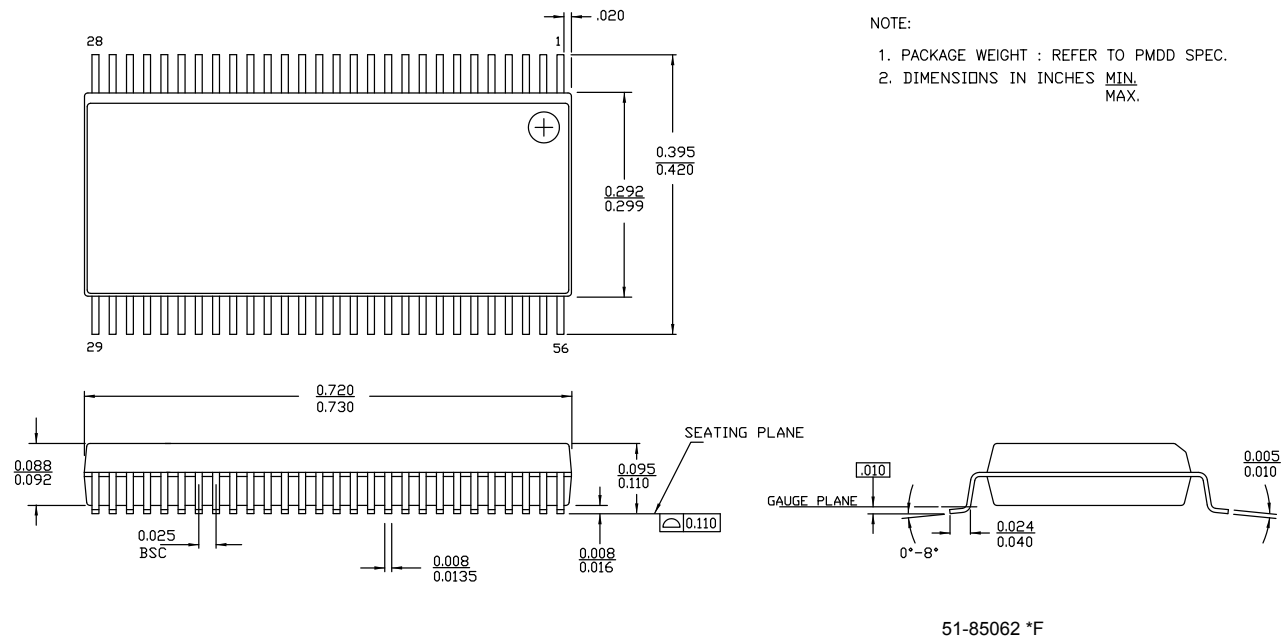



Thermal Impedances

Table 49. Thermal Impedances per Package

Package	Typical θ_{JA} ^[38]
8-pin PDIP	123 °C/W
8-pin SOIC	185 °C/W
20-pin PDIP	109 °C/W
20-pin SSOP	117 °C/W
20-pin SOIC	81 °C/W
28-pin PDIP	69 °C/W
28-pin SSOP	101 °C/W
28-pin SOIC	74 °C/W
32-pin QFN ^[39]	22 °C/W

Capacitance on Crystal Pins

Table 50. Typical Package Capacitance on Crystal Pins

Package	Package Capacitance
8-pin PDIP	2.8 pF
8-pin SOIC	2.0 pF
20-pin PDIP	3.0 pF
20-pin SSOP	2.6 pF
20-pin SOIC	2.5 pF
28-pin PDIP	3.5 pF
28-pin SSOP	2.8 pF
28-pin SOIC	2.7 pF
32-pin QFN	2.0 pF

Solder Reflow Specifications

Table 51 shows the solder reflow temperature limits that must not be exceeded.

Table 51. Solder Reflow Specifications

Package	Maximum Peak Temperature (T_C)	Maximum Time above $T_C - 5\text{ °C}$
8-pin PDIP	260 °C	30 seconds
8-pin SOIC	260 °C	30 seconds
20-pin PDIP	260 °C	30 seconds
20-pin SSOP	260 °C	30 seconds
20-pin SOIC	260 °C	30 seconds
28-pin PDIP	260 °C	30 seconds
28-pin SSOP	260 °C	30 seconds
28-pin SOIC	260 °C	30 seconds
32-pin QFN	260 °C	30 seconds

Notes

38. $T_J = T_A + \text{Power} \times \theta_{JA}$

39. To achieve the thermal impedance specified for the QFN package, refer to *Application Notes for Surface Mount Assembly of Amkor's MicroLeadFrame (MLF) Packages* available at www.amkor.com.

Development Tool Selection

This section presents the development tools available for all current PSoC device families including the CY8C24x23A family.

Software

PSoC Designer™

At the core of the PSoC development software suite is PSoC Designer, used to generate PSoC firmware applications. PSoC Designer is available free of charge at <http://www.cypress.com> and includes a free C compiler.

PSoC Programmer

Flexible enough to be used on the bench in development, yet suitable for factory programming, PSoC Programmer works either as a standalone programming application or it can operate directly from PSoC Designer. PSoC Programmer software is compatible with both PSoC ICE-Cube In-Circuit Emulator and PSoC MiniProg. PSoC programmer is available free of charge at <http://www.cypress.com>.

Development Kits

All development kits can be purchased from the Cypress Online Store.

CY3215-DK Basic Development Kit

The **CY3215-DK** is for prototyping and development with PSoC Designer. This kit supports in-circuit emulation and the software interface lets you to run, halt, and single step the processor and view the content of specific memory locations. Advance emulation features also supported through PSoC Designer. The kit includes:

- PSoC Designer software CD
- ICE-Cube in-circuit emulator
- ICE Flex-Pod for CY8C29x66 family
- Cat-5 adapter
- Mini-Eval programming board
- 110 ~ 240 V power supply, Euro-Plug adapter
- iMAGEcraft C compiler (registration required)
- ISSP cable
- USB 2.0 cable and Blue Cat-5 cable
- 2 CY8C29466-24PXI 28-PDIP chip samples

Evaluation Tools

All evaluation tools can be purchased from the Cypress Online Store.

CY3210-MiniProg1

The **CY3210-MiniProg1** kit lets you to program PSoC devices through the MiniProg1 programming unit. The MiniProg is a small, compact prototyping programmer that connects to the PC through a provided USB 2.0 cable. The kit includes:

- MiniProg programming unit
- MiniEval socket programming and evaluation board
- 28-pin CY8C29466-24PXI PDIP PSoC device sample
- 28-pin CY8C27443-24PXI PDIP PSoC device sample
- PSoC Designer software CD
- Getting Started guide
- USB 2.0 cable

CY3210-PSoCEval1

The **CY3210-PSoCEval1** kit features an evaluation board and the MiniProg1 programming unit. The evaluation board includes an LCD module, potentiometer, LEDs, and plenty of bread-boarding space to meet all of your evaluation needs. The kit includes:

- Evaluation board with LCD module
- MiniProg programming unit
- 28-pin CY8C29466-24PXI PDIP PSoC device sample (2)
- PSoC Designer software CD
- Getting Started guide
- USB 2.0 cable

CY3214-PSoCEvalUSB

The **CY3214-PSoCEvalUSB** evaluation kit features a development board for the CY8C24794-24LFXI PSoC device. Special features of the board include both USB and capacitive sensing development and debugging support. This evaluation board also includes an LCD module, potentiometer, LEDs, an enunciator and plenty of bread boarding space to meet all of your evaluation needs. The kit includes:

- PSoCEvalUSB board
- LCD module
- MiniProg programming unit
- Mini USB cable
- PSoC Designer and Example Projects CD
- Getting Started guide
- Wire pack

Device Programmers

All device programmers can be purchased from the Cypress Online Store.

CY3216 Modular Programmer

The **CY3216 Modular Programmer kit** features a modular programmer and the MiniProg1 programming unit. The modular programmer includes three programming module cards and supports multiple Cypress products. The kit includes:

- Modular programmer base
- Three programming module cards
- MiniProg programming unit
- PSoC Designer software CD
- Getting Started guide
- USB 2.0 cable

CY3207ISSP In-System Serial Programmer (ISSP)

The **CY3207ISSP** is a production programmer. It includes protection circuitry and an industrial case that is more robust than the MiniProg in a production-programming environment.

Note CY3207ISSP needs special software and is not compatible with PSoC Programmer. The kit includes:

- CY3207 programmer unit
- PSoC ISSP software CD
- 110 ~ 240 V power supply, Euro-Plug adapter
- USB 2.0 cable

Accessories (Emulation and Programming)

Table 52. Emulation and Programming Accessories

Part Number	Pin Package	Flex-Pod Kit ^[40]	Foot Kit ^[41]	Adapter ^[42]
All non-QFN	All non-QFN	CY3250-24X23A	CY3250-8DIP-FK, CY3250-8SOIC-FK, CY3250-20DIP-FK, CY3250-20SOIC-FK, CY3250-20SSOP-FK, CY3250-28DIP-FK, CY3250-28SOIC-FK, CY3250-28SSOP-FK	Adapters can be found at http://www.emulation.com .

Notes

40. Flex-Pod kit includes a practice flex-pod and a practice PCB, in addition to two flex-pods.

41. Foot kit includes surface mount feet that can be soldered to the target PCB.

42. Programming adapter converts non-DIP package to DIP footprint. Specific details and ordering information for each of the adapters can be found at <http://www.emulation.com>.

Ordering Information

The following table lists the CY8C24x23A PSoC device's key package features and ordering codes.

Table 53. CY8C24x23A PSoC Device Key Features and Ordering Information

Package	Ordering Code	Flash (Bytes)	SRAM (Bytes)	Switch Mode Pump	Temperature Range	Digital Blocks	Analog Blocks	Digital I/O Pins	Analog Inputs	Analog Outputs	XRES Pin
8-pin (300-mil) DIP	CY8C24123A-24PXI	4K	256	No	-40 °C to +85 °C	4	6	6	4	2	No
8-pin (150-mil) SOIC	CY8C24123A-24SXI	4K	256	No	-40 °C to +85 °C	4	6	6	4	2	No
8-pin (150-mil) SOIC (Tape and Reel)	CY8C24123A-24SXIT	4K	256	No	-40 °C to +85 °C	4	6	6	4	2	No
20-pin (300-mil) DIP	CY8C24223A-24PXI	4K	256	Yes	-40 °C to +85 °C	4	6	16	8	2	Yes
20-pin (210-mil) SSOP	CY8C24223A-24PVXI	4K	256	Yes	-40 °C to +85 °C	4	6	16	8	2	Yes
20-pin (210-mil) SSOP (Tape and Reel)	CY8C24223A-24PVXIT	4K	256	Yes	-40 °C to +85 °C	4	6	16	8	2	Yes
20-pin (300-mil) SOIC	CY8C24223A-24SXI	4K	256	Yes	-40 °C to +85 °C	4	6	16	8	2	Yes
20-pin (300-mil) SOIC (Tape and Reel)	CY8C24223A-24SXIT	4K	256	Yes	-40 °C to +85 °C	4	6	16	8	2	Yes
28-pin (210-mil) SSOP	CY8C24423A-24PVXI	4K	256	Yes	-40 °C to +85 °C	4	6	24	10	2	Yes
28-pin (210-mil) SSOP (Tape and Reel)	CY8C24423A-24PVXIT	4K	256	Yes	-40 °C to +85 °C	4	6	24	10	2	Yes
28-pin (300-mil) SOIC	CY8C24423A-24SXI	4K	256	Yes	-40 °C to +85 °C	4	6	24	10	2	Yes
28-pin (300-mil) SOIC (Tape and Reel)	CY8C24423A-24SXIT	4K	256	Yes	-40 °C to +85 °C	4	6	24	10	2	Yes
32-pin (5 × 5 mm 1.00 max) Sawn QFN	CY8C24423A-24LTXI	4K	256	Yes	-40 °C to +85 °C	4	6	24	10	2	Yes
32-pin (5 × 5 mm 1.00 max) Sawn QFN (Tape and Reel)	CY8C24423A-24LTXIT	4K	256	Yes	-40 °C to +85 °C	4	6	24	10	2	Yes
56-pin OCD SSOP	CY8C24000A-24PVXI ^[43]	4K	256	Yes	-40 °C to +85 °C	4	6	24	10	2	Yes

Note For Die sales information, contact a local Cypress sales office or Field Applications Engineer (FAE).

Ordering Code Definitions

CY 8 C 24 xxx-SPxx

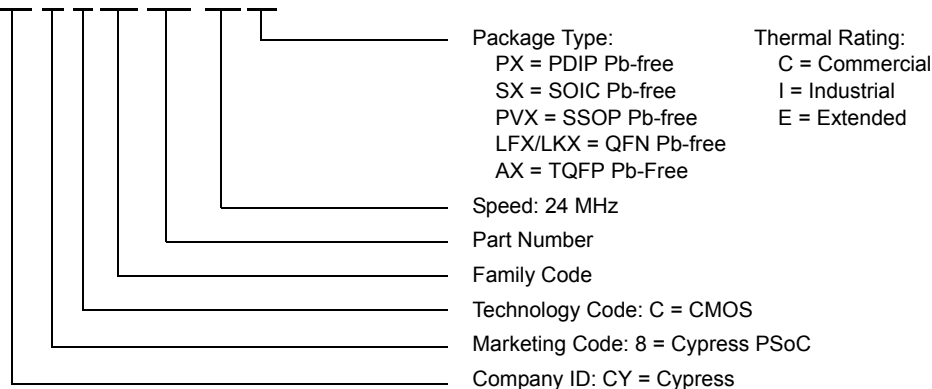

Note

43. This part may be used for in-circuit debugging. It is NOT available for production.

Acronyms

Acronyms Used

Table 54 lists the acronyms that are used in this document.

Table 54. Acronyms Used in this Datasheet

Acronym	Description	Acronym	Description
AC	alternating current	MIPS	million instructions per second
ADC	analog-to-digital converter	OCD	on-chip debug
API	application programming interface	PCB	printed circuit board
CMOS	complementary metal oxide semiconductor	PDIP	plastic dual-in-line package
CPU	central processing unit	PGA	programmable gain amplifier
CRC	cyclic redundancy check	PLL	phase-locked loop
CT	continuous time	POR	power on reset
DAC	digital-to-analog converter	PPOR	precision power on reset
DC	direct current	PRS	pseudo-random sequence
DTMF	dual-tone multi-frequency	PSoC®	Programmable System-on-Chip
ECO	external crystal oscillator	PWM	pulse width modulator
EEPROM	electrically erasable programmable read-only memory	QFN	quad flat no leads
GPIO	general purpose I/O	RTC	real time clock
ICE	in-circuit emulator	SAR	successive approximation
IDE	integrated development environment	SC	switched capacitor
ILO	internal low speed oscillator	SLIMO	slow IMO
IMO	internal main oscillator	SMP	switch mode pump
I/O	input/output	SOIC	small-outline integrated circuit
IrDA	infrared data association	SPI™	serial peripheral interface
ISSP	in-system serial programming	SRAM	static random access memory
LCD	liquid crystal display	SROM	supervisory read only memory
LED	light-emitting diode	SSOP	shrink small-outline package
LPC	low power comparator	UART	universal asynchronous receiver / transmitter
LVD	low voltage detect	USB	universal serial bus
MAC	multiply-accumulate	WDT	watchdog timer
MCU	microcontroller unit	XRES	external reset

Reference Documents

CY8CPLC20, CY8CLED16P01, CY8C29x66, CY8C27x43, CY8C24x94, CY8C24x23, CY8C24x23A, CY8C22x13, CY8C21x34, CY8C21x23, CY7C64215, CY7C603xx, CY8CNP1xx, and CYWUSB6953 PSoC® Programmable System-on-Chip Technical Reference Manual (TRM) (001-14463)

Design Aids – Reading and Writing PSoC® Flash – AN2015 (001-40459)

Application Notes for Surface Mount Assembly of Amkor's MicroLeadFrame (MLF) Packages – available at <http://www.amkor.com>.



Document Conventions

Units of Measure

Table 55 lists the units of measures.

Table 55. Units of Measure

Symbol	Units of Measure	Symbol	Units of Measure
kB	1024 bytes	μs	microsecond
dB	decibels	ms	millisecond
°C	degree Celsius	ns	nanosecond
fF	femto farad	ps	picosecond
pF	picofarad	μV	microvolts
kHz	kilohertz	mV	millivolts
MHz	megahertz	mVpp	millivolts peak-to-peak
rt-Hz	root hertz	nV	nanovolts
kΩ	kilohm	V	volts
Ω	ohm	μW	microwatts
μA	microampere	W	watt
mA	milliampere	mm	millimeter
nA	nanoampere	ppm	parts per million
pA	pikoampere	%	percent
mH	millihenry		

Numeric Conventions

Hexadecimal numbers are represented with all letters in uppercase with an appended lowercase 'h' (for example, '14h' or '3Ah'). Hexadecimal numbers may also be represented by a '0x' prefix, the C coding convention. Binary numbers have an appended lowercase 'b' (for example, '01010100b' or '01000011b'). Numbers not indicated by an 'h' or 'b' are decimals.

Glossary

active high	<ol style="list-style-type: none"> 5. A logic signal having its asserted state as the logic 1 state. 6. A logic signal having the logic 1 state as the higher voltage of the two states.
analog blocks	The basic programmable opamp circuits. These are SC (switched capacitor) and CT (continuous time) blocks. These blocks can be interconnected to provide ADCs, DACs, multi-pole filters, gain stages, and much more.
analog-to-digital (ADC)	A device that changes an analog signal to a digital signal of corresponding magnitude. Typically, an ADC converts a voltage to a digital number. The digital-to-analog (DAC) converter performs the reverse operation.
API (Application Programming Interface)	A series of software routines that comprise an interface between a computer application and lower level services and functions (for example, user modules and libraries). APIs serve as building blocks for programmers that create software applications.
asynchronous	A signal whose data is acknowledged or acted upon immediately, irrespective of any clock signal.
Bandgap reference	A stable voltage reference design that matches the positive temperature coefficient of VT with the negative temperature coefficient of VBE, to produce a zero temperature coefficient (ideally) reference.
bandwidth	<ol style="list-style-type: none"> 1. The frequency range of a message or information processing system measured in hertz. 2. The width of the spectral region over which an amplifier (or absorber) has substantial gain (or loss); it is sometimes represented more specifically as, for example, full width at half maximum.

Glossary (continued)

bias	<ol style="list-style-type: none"> 1. A systematic deviation of a value from a reference value. 2. The amount by which the average of a set of values departs from a reference value. 3. The electrical, mechanical, magnetic, or other force (field) applied to a device to establish a reference level to operate the device.
block	<ol style="list-style-type: none"> 1. A functional unit that performs a single function, such as an oscillator. 2. A functional unit that may be configured to perform one of several functions, such as a digital PSoC block or an analog PSoC block.
buffer	<ol style="list-style-type: none"> 1. A storage area for data that is used to compensate for a speed difference, when transferring data from one device to another. Usually refers to an area reserved for IO operations, into which data is read, or from which data is written. 2. A portion of memory set aside to store data, often before it is sent to an external device or as it is received from an external device. 3. An amplifier used to lower the output impedance of a system.
bus	<ol style="list-style-type: none"> 1. A named connection of nets. Bundling nets together in a bus makes it easier to route nets with similar routing patterns. 2. A set of signals performing a common function and carrying similar data. Typically represented using vector notation; for example, address[7:0]. 3. One or more conductors that serve as a common connection for a group of related devices.
clock	The device that generates a periodic signal with a fixed frequency and duty cycle. A clock is sometimes used to synchronize different logic blocks.
comparator	An electronic circuit that produces an output voltage or current whenever two input levels simultaneously satisfy predetermined amplitude requirements.
compiler	A program that translates a high level language, such as C, into machine language.
configuration space	In PSoC devices, the register space accessed when the XIO bit, in the CPU_F register, is set to '1'.
crystal oscillator	An oscillator in which the frequency is controlled by a piezoelectric crystal. Typically a piezoelectric crystal is less sensitive to ambient temperature than other circuit components.
cyclic redundancy check (CRC)	A calculation used to detect errors in data communications, typically performed using a linear feedback shift register. Similar calculations may be used for a variety of other purposes such as data compression.
data bus	A bi-directional set of signals used by a computer to convey information from a memory location to the central processing unit and vice versa. More generally, a set of signals used to convey data between digital functions.
debugger	A hardware and software system that allows the user to analyze the operation of the system under development. A debugger usually allows the developer to step through the firmware one step at a time, set break points, and analyze memory.
dead band	A period of time when neither of two or more signals are in their active state or in transition.
digital blocks	The 8-bit logic blocks that can act as a counter, timer, serial receiver, serial transmitter, CRC generator, pseudo-random number generator, or SPI.
digital-to-analog (DAC)	A device that changes a digital signal to an analog signal of corresponding magnitude. The analog-to-digital (ADC) converter performs the reverse operation.

Glossary (continued)

duty cycle	The relationship of a clock period high time to its low time, expressed as a percent.
emulator	Duplicates (provides an emulation of) the functions of one system with a different system, so that the second system appears to behave like the first system.
external reset (XRES)	An active high signal that is driven into the PSoC device. It causes all operation of the CPU and blocks to stop and return to a pre-defined state.
flash	An electrically programmable and erasable, non-volatile technology that provides users with the programmability and data storage of EPROMs, plus in-system erasability. Non-volatile means that the data is retained when power is off.
Flash block	The smallest amount of Flash ROM space that may be programmed at one time and the smallest amount of Flash space that may be protected. A Flash block holds 64 bytes.
frequency	The number of cycles or events per unit of time, for a periodic function.
gain	The ratio of output current, voltage, or power to input current, voltage, or power, respectively. Gain is usually expressed in dB.
I ² C	A two-wire serial computer bus by Philips Semiconductors (now NXP Semiconductors). I2C is an Inter-Integrated Circuit. It is used to connect low-speed peripherals in an embedded system. The original system was created in the early 1980s as a battery control interface, but it was later used as a simple internal bus system for building control electronics. I2C uses only two bi-directional pins, clock and data, both running at +5 V and pulled high with resistors. The bus operates at 100 kbits/second in standard mode and 400 kbits/second in fast mode.
ICE	The in-circuit emulator that allows users to test the project in a hardware environment, while viewing the debugging device activity in a software environment (PSoC Designer).
input/output (I/O)	A device that introduces data into or extracts data from a system.
interrupt	A suspension of a process, such as the execution of a computer program, caused by an event external to that process, and performed in such a way that the process can be resumed.
interrupt service routine (ISR)	A block of code that normal code execution is diverted to when the M8C receives a hardware interrupt. Many interrupt sources may each exist with its own priority and individual ISR code block. Each ISR code block ends with the RETI instruction, returning the device to the point in the program where it left normal program execution.
jitter	<ol style="list-style-type: none">1. A misplacement of the timing of a transition from its ideal position. A typical form of corruption that occurs on serial data streams.2. The abrupt and unwanted variations of one or more signal characteristics, such as the interval between successive pulses, the amplitude of successive cycles, or the frequency or phase of successive cycles.
low-voltage detect (LVD)	A circuit that senses V _{DD} and provides an interrupt to the system when V _{DD} falls lower than a selected threshold.
M8C	An 8-bit Harvard-architecture microprocessor. The microprocessor coordinates all activity inside a PSoC by interfacing to the Flash, SRAM, and register space.
master device	A device that controls the timing for data exchanges between two devices. Or when devices are cascaded in width, the master device is the one that controls the timing for data exchanges between the cascaded devices and an external interface. The controlled device is called the slave device .

Glossary (continued)

microcontroller	An integrated circuit chip that is designed primarily for control systems and products. In addition to a CPU, a microcontroller typically includes memory, timing circuits, and IO circuitry. The reason for this is to permit the realization of a controller with a minimal quantity of chips, thus achieving maximal possible miniaturization. This in turn, reduces the volume and the cost of the controller. The microcontroller is normally not used for general-purpose computation as is a microprocessor.
mixed-signal	The reference to a circuit containing both analog and digital techniques and components.
modulator	A device that imposes a signal on a carrier.
noise	<ol style="list-style-type: none">1. A disturbance that affects a signal and that may distort the information carried by the signal.2. The random variations of one or more characteristics of any entity such as voltage, current, or data.
oscillator	A circuit that may be crystal controlled and is used to generate a clock frequency.
parity	A technique for testing transmitting data. Typically, a binary digit is added to the data to make the sum of all the digits of the binary data either always even (even parity) or always odd (odd parity).
phase-locked loop (PLL)	An electronic circuit that controls an oscillator so that it maintains a constant phase angle relative to a reference signal.
pinouts	The pin number assignment: the relation between the logical inputs and outputs of the PSoC device and their physical counterparts in the printed circuit board (PCB) package. Pinouts involve pin numbers as a link between schematic and PCB design (both being computer generated files) and may also involve pin names.
port	A group of pins, usually eight.
power on reset (POR)	A circuit that forces the PSoC device to reset when the voltage is lower than a pre-set level. This is one type of hardware reset.
PSoC®	Cypress Semiconductor's PSoC® is a registered trademark and Programmable System-on-Chip™ is a trademark of Cypress.
PSoC Designer™	The software for Cypress' Programmable System-on-Chip technology.
pulse width modulator (PWM)	An output in the form of duty cycle which varies as a function of the applied measurand.
RAM	An acronym for random access memory. A data-storage device from which data can be read out and new data can be written in.
register	A storage device with a specific capacity, such as a bit or byte.
reset	A means of bringing a system back to a know state. See hardware reset and software reset.
ROM	An acronym for read only memory. A data-storage device from which data can be read out, but new data cannot be written in.
serial	<ol style="list-style-type: none">1. Pertaining to a process in which all events occur one after the other.2. Pertaining to the sequential or consecutive occurrence of two or more related activities in a single device or channel.
settling time	The time it takes for an output signal or value to stabilize after the input has changed from one value to another.

Glossary (continued)

shift register	A memory storage device that sequentially shifts a word either left or right to output a stream of serial data.
slave device	A device that allows another device to control the timing for data exchanges between two devices. Or when devices are cascaded in width, the slave device is the one that allows another device to control the timing of data exchanges between the cascaded devices and an external interface. The controlling device is called the master device.
SRAM	An acronym for static random access memory. A memory device allowing users to store and retrieve data at a high rate of speed. The term static is used because, after a value has been loaded into an SRAM cell, it remains unchanged until it is explicitly altered or until power is removed from the device.
SROM	An acronym for supervisory read only memory. The SROM holds code that is used to boot the device, calibrate circuitry, and perform Flash operations. The functions of the SROM may be accessed in normal user code, operating from Flash.
stop bit	A signal following a character or block that prepares the receiving device to receive the next character or block.
synchronous	<ol style="list-style-type: none">1. A signal whose data is not acknowledged or acted upon until the next active edge of a clock signal.2. A system whose operation is synchronized by a clock signal.
tri-state	A function whose output can adopt three states: 0, 1, and Z (high-impedance). The function does not drive any value in the Z state and, in many respects, may be considered to be disconnected from the rest of the circuit, allowing another output to drive the same net.
UART	A UART or universal asynchronous receiver-transmitter translates between parallel bits of data and serial bits.
user modules	Pre-build, pre-tested hardware/firmware peripheral functions that take care of managing and configuring the lower level Analog and Digital PSoC Blocks. User Modules also provide high level API (Application Programming Interface) for the peripheral function.
user space	The bank 0 space of the register map. The registers in this bank are more likely to be modified during normal program execution and not just during initialization. Registers in bank 1 are most likely to be modified only during the initialization phase of the program.
V _{DD}	A name for a power net meaning “voltage drain.” The most positive power supply signal. Usually 5 V or 3.3 V.
V _{SS}	A name for a power net meaning “voltage source.” The most negative power supply signal.
watchdog timer	A timer that must be serviced periodically. If it is not serviced, the CPU resets after a specified period of time.

Errata

This section describes the errata for the CY8C24xxx device family. Details include errata trigger conditions, scope of impact, available workaround, and silicon revision applicability. Contact your local Cypress Sales Representative if you have questions.

Part Numbers Affected

Part Number	Ordering Information
CY8C24123A	CY8C24123A-24PXI
	CY8C24123A-24SXI
	CY8C24123A-24SXIT
	CY8C24223A-24PXI
	CY8C24223A-24PVXI
	CY8C24223A-24PVXIT
	CY8C24223A-24SXI
	CY8C24223A-24SXIT
	CY8C24423A-24PVXI
	CY8C24423A-24PVXIT
	CY8C24423A-24SXI
	CY8C24423A-24SXIT
	CY8C24423A-24LFXI
	CY8C24423A-24LTXI
	CY8C24423A-24LTXIT
	CY8C24000A-24PVXI

CY8C24123A Qualification Status

Product Status: Production

CY8C24123A Errata Summary

The following table defines the errata applicability to available CY8C24123A family devices.

Items	Part Number	Silicon Revision	Fix Status
[1.]. Internal Main Oscillator (IMO) Tolerance Deviation at Temperature Extremes	CY8C24123A	*A	No silicon fix planned. Workaround is required.

1. Internal Main Oscillator (IMO) Tolerance Deviation at Temperature Extremes

■ Problem Definition

Asynchronous Digital Communications Interfaces may fail framing beyond 0 to 70 °C. This problem does not affect end-product usage between 0 and 70 °C.

■ Parameters Affected

The IMO frequency tolerance. The worst case deviation when operated below 0°C and above +70 °C and within the upper and lower datasheet temperature range is ±5%.

■ Trigger Condition(S)

The asynchronous Rx/Tx clock source IMO frequency tolerance may deviate beyond the data sheet limit of ±2.5% when operated beyond the temperature range of 0 to +70 °C.

■ Scope of Impact

This problem may affect UART, IrDA, and FSK implementations.

■ Workaround

Implement a quartz crystal stabilized clock source on at least one end of the asynchronous digital communications interface.

■ Fix Status

Silicon fix is not planned. The workaround mentioned above should be used.

Document History Page

Document Title: CY8C24123A/CY8C24223A/CY8C24423A, PSoC® Programmable System-on-Chip Document Number: 38-12028				
Revision	ECN	Orig. of Change	Submission Date	Description of Change
**	236409	SFV	See ECN	New silicon and new document – Preliminary datasheet.
*A	247589	SFV	See ECN	Changed the title to read “Final” datasheet. Updated Electrical Specifications chapter.
*B	261711	HMT	See ECN	Input all SFV memo changes. Updated Electrical Specifications chapter.
*C	279731	HMT	See ECN	Update Electrical Specifications chapter, including 2.7 VIL DC GPIO spec. Add Solder Reflow Peak Temperature table. Clean up pinouts and fine tune wording and format throughout.
*D	352614	HMT	See ECN	Add new color and CY logo. Add URL to preferred dimensions for mounting MLF packages. Update Transmitter and Receiver AC Digital Block Electrical Specifications. Re-add ISSP pinout identifier. Delete Electrical Specification sentence re: devices running at greater than 12 MHz. Update Solder Reflow Peak Temperature table. Fix CY.com URLs. Update CY copyright.
*E	424036	HMT	See ECN	Fix SMP 8-pin SOIC error in Feature and Order table. Update 32-pin QFN E-Pad dimensions and rev. *A. Add ISSP note to pinout tables. Update typical and recommended Storage Temperature per industrial specs. Add OCD non-production pinout and package diagram. Update CY branding and QFN convention. Update package diagram revisions.
*F	521439	HMT	See ECN	Add Low Power Comparator (LPC) AC/DC electrical spec. tables. Add new Dev. Tool section. Add CY8C20x34 to PSoC Device Characteristics table.
*G	2256806	UVS / PYRS	See ECN	Added Sawn pin information.
*H	2425586	DSO / AESA	See ECN	Corrected Ordering Information to include CY8C24423A-24LTXI and CY8C24423A-24LTXIT
*I	2619935	OGNE / AESA	12/11/2008	Changed title to “CY8C24123A, CY8C24223A, CY8C24423A PSoC® Programmable System-on-Chip™” Updated package diagram 001-30999 to *A. Added note on digital signaling in DC Analog Reference Specifications on page 28 . Added Die Sales information note to Ordering Information on page 60 .
*J	2692871	DPT / PYRS	04/16/2009	Updated Max package thickness for 32-pin QFN package Formatted Notes Updated “ Getting Started ” on page 7 Updated “ Development Tools ” on page 8 and “ Designing with PSoC Designer ” on page 9
*K	2762168	JVY / AESA	06/25/2009	Updated DC GPIO, AC Chip-Level, and AC Programming Specifications as follows: Modified FIMO6 and TWRITE specifications. Replaced T _{RAMP} (time) specification with SR _{POWER_UP} (slew rate) specification. Added note [9] to Flash Endurance specification. Added IOH, IOL, DC _{ILO} , F _{32K_U} , T _{POWERUP} , T _{ERASEALL} , T _{PROGRAM_HOT} , and T _{PROGRAM_COLD} specifications.

Document History Page (continued)

Document Title: CY8C24123A/CY8C24223A/CY8C24423A, PSoC® Programmable System-on-Chip				
Document Number: 38-12028				
Revision	ECN	Orig. of Change	Submission Date	Description of Change
*L	2897881	MAXK / NJF	03/23/2010	Add " More Information " on page 2. Update unit in Table 10-28 and Table 39 of SPIS Maximum Input Clock Frequency from ns to MHz. Update revision of package diagrams for 8 PDIP, 8 SOIC, 20 PDIP, 20 SSOP, 20 SOIC, 28 PDIP, 28 SSOP, 28 SOIC, 32 QFN. Updated Cypress website links. Removed reference to PSoC Designer 4.4. Updated 56-Pin SSOP definitions and diagram. Added T _{BAKETEMP} and T _{BAKETIME} parameters in Absolute Maximum Ratings . Updated 5 V DC Analog Reference Specifications table. Updated Note in Packaging Information . Added Note 29. Updated Solder Reflow Specifications table. Removed Third Party Tools and Build a PSoC Emulator into your Board. Removed inactive parts from Ordering Information . Update trademark info. and Sales, Solutions, and Legal Information .
*M	2942375	VMAD	06/02/2010	Updated content to match current style guide and datasheet template. No technical updates.
*N	3032514	NJF	09/17/10	Added PSoC Device Characteristics table. Added DC I ² C Specifications table. Added F _{32K_U} max limit. Added T _{jitter_IMO} specification, removed existing jitter specifications. Updated Analog reference tables. Updated Units of Measure, Acronyms, Glossary, and References sections. Updated solder reflow specifications. No specific changes were made to AC Digital Block Specifications table and I ² C Timing Diagram. They were updated for clearer understanding. Updated Figure 13 since the labelling for y-axis was incorrect. Template and styles update.
*O	3098766	YJI	12/01/2010	No technical updates. Completing Sunset Review.
*P	3351721	YJI	08/31/2011	Full annual review of document. No changes are required.
*Q	3367463	BTK / GIR	09/22/2011	Updated text under DC Analog Reference Specifications on page 28 . Removed package diagram spec 51-85188 as there is no active MPN using this outline drawing. The text "Pin must be left floating" is included under Description of NC pin in Table 5 on page 13 and Table 6 on page 14 . Updated Table 51 on page 57 to give more clarity. Removed Footnote #35.
*R	3598291	LURE / XZNG	04/24/2012	Changed the PWM description string from "8- to 32-bit" to "8- and 16-bit".
*S	3991993	PMAD	05/08/2013	Updated Packaging Information : spec 51-85066 – Changed revision from *E to *F. spec 51-85014 – Changed revision from *F to *G. spec 51-85026 – Changed revision from *F to *G. spec 001-30999 – Changed revision from *C to *D. spec 51-85062 – Changed revision from *E to *F. Updated Reference Documents (Removed 001-17397 spec, 001-14503 spec related information). Added Errata .

Document History Page (continued)

Document Title: CY8C24123A/CY8C24223A/CY8C24423A, PSoC® Programmable System-on-Chip				
Document Number: 38-12028				
Revision	ECN	Orig. of Change	Submission Date	Description of Change
*T	4066332	PMAD	07/17/2013	Added Errata Footnotes (Note 1, 19). Updated PSoC Functional Overview : Updated PSoC Core : Added Note 1 and referred the same note in 4th paragraph in PSoC Core. Updated Electrical Specifications : Updated AC Electrical Characteristics : Updated AC Chip-Level Specifications : Added Note 19 and referred the same note in F _{IMO24} parameter. Updated minimum and maximum values of F _{IMO24} parameter. Updated AC Digital Block Specifications : Replaced all instances of maximum value "49.2" with "50.4" and "24.6" with "25.2" in Table 38 . Updated to new template.
*U	4479672	RJVB	08/20/2014	Updated Packaging Information : Updated Packaging Dimensions : spec 51-85011 – Changed revision from *C to *D. spec 51-85024 – Changed revision from *E to *F. spec 51-85026 – Changed revision from *G to *H. Updated Errata : Updated CY8C24123A Errata Summary : Updated details in "Fix Status" column in the table. Updated details in "Fix Status" bulleted point below the table. Completing Sunset Review.
*V	4622083	RKRM	01/13/2015	Added More Information .
*W	5688158	XKJ	05/03/2017	Updated Packaging Information : Updated Packaging Dimensions : spec 51-85066 – Changed revision from *G to *H. Updated Ordering Information : Updated part numbers. Updated Errata : Updated Part Numbers Affected : Updated part numbers. Updated to new template.



Sales, Solutions, and Legal Information

Worldwide Sales and Design Support

Cypress maintains a worldwide network of offices, solution centers, manufacturer's representatives, and distributors. To find the office closest to you, visit us at [Cypress Locations](#).

Products

ARM® Cortex® Microcontrollers	cypress.com/arm
Automotive	cypress.com/automotive
Clocks & Buffers	cypress.com/clocks
Interface	cypress.com/interface
Internet of Things	cypress.com/iot
Memory	cypress.com/memory
Microcontrollers	cypress.com/mcu
PSoC	cypress.com/psoc
Power Management ICs	cypress.com/pmic
Touch Sensing	cypress.com/touch
USB Controllers	cypress.com/usb
Wireless Connectivity	cypress.com/wireless

PSoC® Solutions

[PSoC 1](#) | [PSoC 3](#) | [PSoC 4](#) | [PSoC 5LP](#)

Cypress Developer Community

[Forums](#) | [WICED IOT Forums](#) | [Projects](#) | [Video](#) | [Blogs](#) | [Training](#) | [Components](#)

Technical Support

cypress.com/support



© Cypress Semiconductor Corporation, 2004–2017. This document is the property of Cypress Semiconductor Corporation and its subsidiaries, including Spansion LLC ("Cypress"). This document, including any software or firmware included or referenced in this document ("Software"), is owned by Cypress under the intellectual property laws and treaties of the United States and other countries worldwide. Cypress reserves all rights under such laws and treaties and does not, except as specifically stated in this paragraph, grant any license under its patents, copyrights, trademarks, or other intellectual property rights. If the Software is not accompanied by a license agreement and you do not otherwise have a written agreement with Cypress governing the use of the Software, then Cypress hereby grants you a personal, non-exclusive, nontransferable license (without the right to sublicense) (1) under its copyright rights in the Software (a) for Software provided in source code form, to modify and reproduce the Software solely for use with Cypress hardware products, only internally within your organization, and (b) to distribute the Software in binary code form externally to end users (either directly or indirectly through resellers and distributors), solely for use on Cypress hardware product units, and (2) under those claims of Cypress's patents that are infringed by the Software (as provided by Cypress, unmodified) to make, use, distribute, and import the Software solely for use with Cypress hardware products. Any other use, reproduction, modification, translation, or compilation of the Software is prohibited.

TO THE EXTENT PERMITTED BY APPLICABLE LAW, CYPRESS MAKES NO WARRANTY OF ANY KIND, EXPRESS OR IMPLIED, WITH REGARD TO THIS DOCUMENT OR ANY SOFTWARE OR ACCOMPANYING HARDWARE, INCLUDING, BUT NOT LIMITED TO, THE IMPLIED WARRANTIES OF MERCHANTABILITY AND FITNESS FOR A PARTICULAR PURPOSE. To the extent permitted by applicable law, Cypress reserves the right to make changes to this document without further notice. Cypress does not assume any liability arising out of the application or use of any product or circuit described in this document. Any information provided in this document, including any sample design information or programming code, is provided only for reference purposes. It is the responsibility of the user of this document to properly design, program, and test the functionality and safety of any application made of this information and any resulting product. Cypress products are not designed, intended, or authorized for use as critical components in systems designed or intended for the operation of weapons, weapons systems, nuclear installations, life-support devices or systems, other medical devices or systems (including resuscitation equipment and surgical implants), pollution control or hazardous substances management, or other uses where the failure of the device or system could cause personal injury, death, or property damage ("Unintended Uses"). A critical component is any component of a device or system whose failure to perform can be reasonably expected to cause the failure of the device or system, or to affect its safety or effectiveness. Cypress is not liable, in whole or in part, and you shall and hereby do release Cypress from any claim, damage, or other liability arising from or related to all Unintended Uses of Cypress products. You shall indemnify and hold Cypress harmless from and against all claims, costs, damages, and other liabilities, including claims for personal injury or death, arising from or related to any Unintended Uses of Cypress products.





Cypress, the Cypress logo, Spansion, the Spansion logo, and combinations thereof, WICED, PSoC, CapSense, EZ-USB, F-RAM, and Traveo are trademarks or registered trademarks of Cypress in the United States and other countries. For a more complete list of Cypress trademarks, visit cypress.com. Other names and brands may be claimed as property of their respective owners.

Looking for pricing, stock, or lifecycle information?

Click below to explore more details on WIN SOURCE:

-  [View CY8C24423A-24PVXIT on WIN SOURCE](#)
-  [Cypress Semiconductor Corp Information](#)

Optimize Your Supply Chain with WIN SOURCE Solutions

-  Global Sourcing Solution
-  Obsolete Management
-  Cost Control Management
-  Shortage Management
-  Alternative Solution
-  Excess Inventory Management