



**THE DATASHEET OF  
CY8C24423A-12PVXET**



# Automotive - Extended Temperature PSoC<sup>®</sup> Programmable System-on-Chip

## Features

- AEC qualified
- Powerful Harvard architecture processor
  - M8C processor speeds up to 12 MHz
  - 8x8 multiply, 32-bit accumulate
  - Low power at high speed
  - 4.75V to 5.25V operating voltage
  - Automotive temperature range: -40°C to +125°C
- Advanced peripherals (PSoC<sup>®</sup> blocks)
  - Six rail-to-rail analog PSoC blocks provide:
    - Up to 14-Bit Analog-to-Digital Converters (ADCs)
    - Up to 9-Bit Digital-to-Analog Converters (DACs)
    - Programmable Gain Amplifiers (PGAs)
    - Programmable filters and comparators
  - Four digital PSoC blocks provide:
    - 8- to 32-bit timers and counters, 8- and 16-bit pulse-width modulators (PWMs)
    - CRC and PRS modules
    - Full- or Half-Duplex UART
    - SPI master or slave
    - Connectable to all General Purpose I/O (GPIO) pins
  - Complex peripherals by combining blocks
- Precision, programmable clocking
  - Internal ±4% 24 MHz oscillator
  - High accuracy 24 MHz with optional 32 kHz crystal and Phase Locked Loop (PLL)
  - Optional external oscillator, up to 24 MHz
  - Internal low speed, low power oscillator for Watchdog and Sleep functionality
- Flexible on-chip memory
  - 4K bytes Flash program storage, 100 erase/write cycles
  - 256 bytes SRAM data storage
  - In-System Serial Programming (ISSP)
  - Partial Flash updates
  - Flexible protection modes
  - EEPROM emulation in Flash
- Programmable pin configurations
  - 25 mA Sink, 10 mA Drive on all GPIO
  - Pull up, pull down, High Z, strong, or open drain drive modes on all GPIO
  - Up to 12 analog inputs on GPIO<sup>[1]</sup>
  - Two 30 mA analog outputs on GPIO
  - Configurable interrupt on all GPIO

- Additional system resources
  - I<sup>2</sup>C™ slave, master, or multi-master operation up to 400 kHz
  - Watchdog and Sleep timers
  - User-configurable Low Voltage Detection (LVD)
  - Integrated supervisory circuit
  - On-chip precision voltage reference
- Complete development tools
  - Free development software (PSoC Designer™)
  - Full Featured, In-Circuit Emulator (ICE) and Programmer
  - Full speed emulation
  - Complex breakpoint structure
  - 128K bytes trace memory

## Logic Block Diagram

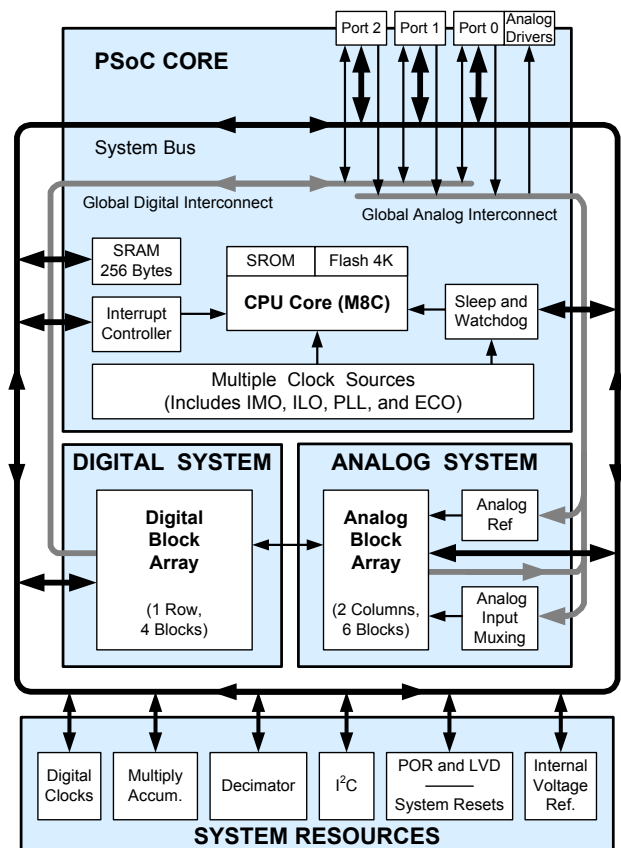

### Note

1. There are eight standard analog inputs on the GPIO. The other four analog inputs connect from the GPIO directly to specific switched-capacitor block inputs. See the *PSoC Technical Reference Manual* for more details

## Contents

<b>PSoC Functional Overview</b> .....	<b>3</b>	<b>Registers</b> .....	<b>11</b>
PSoC Core .....	3	Register Conventions .....	11
Digital System .....	3	Register Mapping Tables .....	11
Analog System .....	4	<b>Electrical Specifications</b> .....	<b>14</b>
Additional System Resources .....	5	Absolute Maximum Ratings .....	15
PSoC Device Characteristics .....	5	Operating Temperature .....	15
<b>Getting Started</b> .....	<b>5</b>	DC Electrical Characteristics .....	16
Application Notes .....	5	AC Electrical Characteristics .....	21
Development Kits .....	5	<b>Packaging Information</b> .....	<b>28</b>
Training .....	5	Thermal Impedances .....	29
CYPros Consultants .....	5	Capacitance on Crystal Pins .....	29
Solutions Library .....	5	Solder Reflow Specifications .....	29
Technical Support .....	5	<b>Development Tool Selection</b> .....	<b>30</b>
<b>Development Tools</b> .....	<b>6</b>	Software .....	30
PSoC Designer Software Subsystems .....	6	Development Kits .....	30
<b>Designing with PSoC Designer</b> .....	<b>7</b>	Evaluation Tools .....	30
Select User Modules .....	7	Device Programmers .....	31
Configure User Modules .....	7	Accessories (Emulation and Programming) .....	31
Organize and Connect .....	7	<b>Ordering Information</b> .....	<b>32</b>
Generate, Verify, and Debug .....	7	Ordering Code Definitions .....	32
<b>Document Conventions</b> .....	<b>8</b>	<b>Document History Page</b> .....	<b>33</b>
Acronyms Used .....	8	<b>Sales, Solutions, and Legal Information</b> .....	<b>34</b>
Units of Measure .....	8	Worldwide Sales and Design Support .....	34
Numeric Naming .....	8	Products .....	34
<b>Pinouts</b> .....	<b>9</b>	PSoC® Solutions .....	34
20-Pin Part Pinout .....	9	Cypress Developer Community .....	34
28-Pin Part Pinout .....	10	Technical Support .....	34

## PSoC Functional Overview

The PSoC family consists of many programmable system-on-chips with on-chip Controller devices. These devices are designed to replace multiple traditional microcontroller unit (MCU)-based system components with one, low cost single-chip programmable device. PSoC devices include configurable blocks of analog and digital logic, and programmable interconnects. This architecture enables the user to create customized peripheral configurations that match the requirements of each individual application. Additionally, a fast CPU, Flash program memory, SRAM data memory, and configurable I/O are included in a range of convenient pinouts and packages.

The PSoC architecture, as shown in the [Logic Block Diagram](#) on page 1, is comprised of four main areas: PSoC Core, Digital System, Analog System, and System Resources. Configurable global buses allow all the device resources to be combined into a complete custom system. Each CY8C24x23A PSoC device includes four digital blocks and six analog blocks. Depending on the PSoC package, up to 24 GPIO are also included. The GPIO provide access to the global digital and analog interconnects.

### PSoC Core

The PSoC Core is a powerful engine that supports a rich feature set. The core includes a CPU, memory, clocks, and configurable GPIO.

The M8C CPU core is a powerful processor with speeds up to 12 MHz, providing a two MIPS 8-bit Harvard architecture microprocessor. The CPU uses an interrupt controller with multiple vectors, to simplify programming of real time embedded events. Program execution is timed and protected using the included Sleep Timer and Watchdog Timer (WDT).

Memory includes 4 KB of Flash for program storage and 256 bytes of SRAM for data storage. Program Flash uses four protection levels on blocks of 64 bytes, allowing customized software IP protection.

The PSoC device incorporates flexible internal clock generators, including a 24 MHz IMO (internal main oscillator) accurate to  $\pm 4\%$  over temperature and voltage. A low power 32 kHz internal low speed oscillator (ILO) is provided for the Sleep Timer and WDT. If crystal accuracy is desired, the ECO (32.768 kHz external crystal oscillator) is available for use as a Real Time Clock (RTC) and can optionally generate a crystal-accurate 24 MHz system clock using a PLL. The clocks, together with programmable clock dividers (as a System Resource), provide the flexibility to integrate almost any timing requirement into the PSoC device.

PSoC GPIOs provide connection to the CPU, digital, and analog resources of the device. Each pin's drive mode may be selected from eight options, allowing great flexibility in external interfacing. Every pin also has the capability to generate a system interrupt.

## Digital System

The Digital System is composed of four digital PSoC blocks. Each block is an 8-bit resource that can be used alone or combined with other blocks to form 8, 16, 24, and 32-bit peripherals, which are called user modules.

**Figure 1. Digital System Block Diagram**

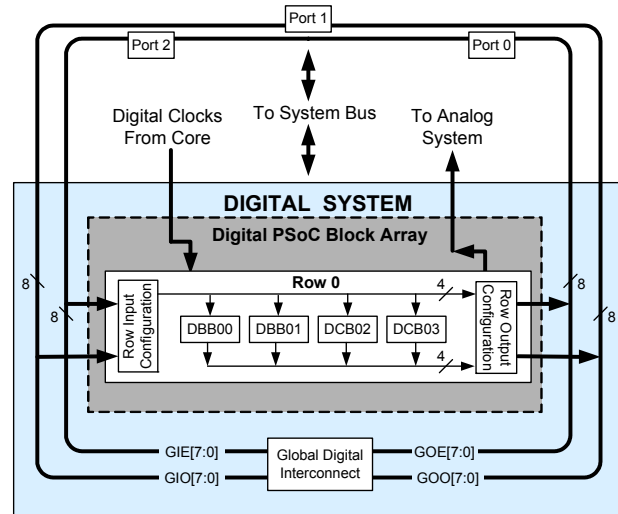

Digital peripheral configurations include:

- PWMs (8- and 16-bit)
- PWMs with Dead Band (8- and 16-bit)
- Counters (8 to 32 bit)
- Timers (8 to 32 bit)
- Full or Half-Duplex 8-bit UART with selectable parity
- SPI master and slave
- I<sup>2</sup>C master, slave, or multi-master
- Cyclical Redundancy Checker/Generator (16 bit)
- IrDA
- Pseudo Random Sequence Generators (8 to 32 bit)

The digital blocks can be connected to any GPIO through a series of global buses that can route any signal to any pin. The buses also allow for signal multiplexing and for performing logic operations. This configurability frees your designs from the constraints of a fixed peripheral controller.

Digital blocks are provided in rows of four, where the number of blocks varies by PSoC device family. This allows the optimum choice of system resources for your application. Family resources are shown in [Table 1](#) on page 5.

### Analog System

The Analog System is composed of six configurable blocks, each comprised of an opamp circuit allowing the creation of complex analog signal flows. Analog peripherals are very flexible and can be customized to support specific application requirements. Some of the common PSoC analog functions for this device (most available as user modules) are:

- ADCs (up to two, with 6 to 14-bit resolution, selectable as Incremental, Delta-Sigma, and SAR)
- Filters (two and four pole band-pass, low-pass, and notch)
- Amplifiers (up to two, with selectable gain up to 48x)
- Instrumentation amplifiers (one with selectable gain up to 93x)
- Comparators (up to two, with 16 selectable thresholds)
- DACs (up to two, with 6 to 9-bit resolution)
- Multiplying DACs (up to two, with 6 to 9-bit resolution)
- High current output drivers (two with 30 mA drive)
- 1.3V reference (as a System Resource)
- DTMF Dialer
- Modulators
- Correlators
- Peak Detectors
- Many other topologies possible

Analog blocks are arranged in a column of three, which includes one Continuous Time (CT) and two Switched Capacitor (SC) blocks, as shown in [Figure 2](#).

Figure 2. Analog System Block Diagram

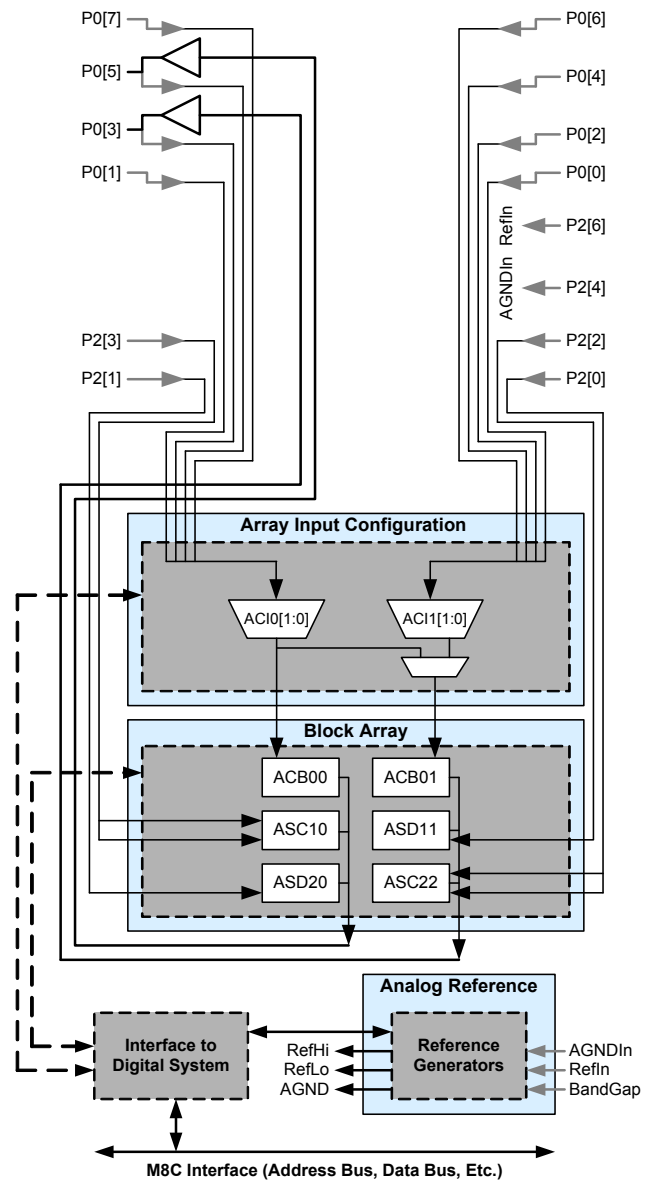

## Additional System Resources

System Resources, some of which have been previously listed, provide additional capability useful for complete systems. Additional resources include a multiplier, decimator, low voltage detection, and power on reset. Brief statements describing the merits of each system resource follow:

- Digital clock dividers provide three customizable clock frequencies for use in applications. The clocks can be routed to both the digital and analog systems. Additional clocks can be generated using digital PSoC blocks as clock dividers.
- A multiply accumulate (MAC) provides a fast 8-bit multiplier with 32-bit accumulate, to assist in both general math as well as digital filters.
- The decimator provides a custom hardware filter for digital signal processing applications including the creation of Delta Sigma ADCs.
- The I<sup>2</sup>C module provides 0 to 400 kHz communication over two wires. Slave, master, and multi-master modes are all supported.
- LVD interrupts can signal the application of falling voltage levels, while the advanced POR (Power On Reset) circuit eliminates the need for a system supervisor.
- An internal 1.3V voltage reference provides an absolute reference for the analog system, including ADCs and DACs.

## Getting Started

For in-depth information, along with detailed programming details, see the PSoC® [Technical Reference Manual](#).

For up-to-date ordering, packaging, and electrical specification information, see the latest [PSoC device datasheets](#) on the web.

## Application Notes

[Cypress application notes](#) are an excellent introduction to the wide variety of possible PSoC designs.

## Development Kits

[PSoC Development Kits](#) are available online from and through a growing number of regional and global distributors, which include Arrow, Avnet, Digi-Key, Farnell, Future Electronics, and Newark.

## Training

[Free PSoC technical training](#) (on demand, webinars, and workshops), which is available online via [www.cypress.com](http://www.cypress.com), covers a wide variety of topics and skill levels to assist you in your designs.

## PSoC Device Characteristics

Depending on your PSoC device characteristics, the digital and analog systems can have a varying number of digital and analog blocks. The following table lists the resources available for specific PSoC device groups. The PSoC device covered by this data sheet is highlighted in [Table 1](#).

**Table 1. PSoC Device Characteristics**

PSoC Part Number	Digital I/O	Digital Rows	Digital Blocks	Analog Inputs	Analog Outputs	Analog Columns	Analog Blocks	SRAM Size	Flash Size
CY8C29x66 <sup>[2]</sup>	up to 64	4	16	12	4	4	12	2K	32K
CY8C27x43	up to 44	2	8	12	4	4	12	256 Bytes	16K
CY8C24x94	64	1	4	48	2	2	6	1K	16K
CY8C24x23A <sup>[2]</sup>	up to 24	1	4	12	2	2	6	256 Bytes	4K
CY8C23x33	up to	1	4	12	2	2	4	256 Bytes	8K
CY8C21x34 <sup>[2]</sup>	up to 28	1	4	28	0	2	4 <sup>[3]</sup>	512 Bytes	8K
CY8C21x23	16	1	4	8	0	2	4 <sup>[3]</sup>	256 Bytes	4K
CY8C20x34	up to 28	0	0	28	0	0	3 <sup>[3, 4]</sup>	512 Bytes	8K

## CYPros Consultants

Certified PSoC consultants offer everything from technical assistance to completed PSoC designs. To contact or become a PSoC consultant go to the [CYPros Consultants](#) web site.

## Solutions Library

Visit our growing [library of solution focused designs](#). Here you can find various application designs that include firmware and hardware design files that enable you to complete your designs quickly.

## Technical Support

[Technical support](#) – including a searchable Knowledge Base articles and technical forums – is also available online. If you cannot find an answer to your question, call our Technical Support hotline at 1-800-541-4736.

### Notes

2. Automotive qualified devices available in this group.
3. Limited analog functionality.
4. Two analog blocks and one CapSense™ block.

## Development Tools

PSoC Designer™ is the revolutionary integrated design environment (IDE) that you can use to customize PSoC to meet your specific application requirements. PSoC Designer software accelerates system design and time to market. Develop your applications using a library of precharacterized analog and digital peripherals (called user modules) in a drag-and-drop design environment. Then, customize your design by leveraging the dynamically generated application programming interface (API) libraries of code. Finally, debug and test your designs with the integrated debug environment, including in-circuit emulation and standard software debug features. PSoC Designer includes:

- Application editor graphical user interface (GUI) for device and user module configuration and dynamic reconfiguration
- Extensive user module catalog
- Integrated source-code editor (C and assembly)
- Free C compiler with no size restrictions or time limits
- Built-in debugger
- In-circuit emulation
- Built-in support for communication interfaces:
  - Hardware and software I<sup>2</sup>C slaves and masters
  - Full-speed USB 2.0
  - Up to four full-duplex universal asynchronous receiver/transmitters (UARTs), SPI master and slave, and wireless

PSoC Designer supports the entire library of PSoC 1 devices and runs on Windows XP, Windows Vista, and Windows 7.

## PSoC Designer Software Subsystems

### *Design Entry*

In the chip-level view, choose a base device to work with. Then select different onboard analog and digital components that use the PSoC blocks, which are called user modules. Examples of user modules are ADCs, DACs, amplifiers, and filters. Configure the user modules for your chosen application and connect them to each other and to the proper pins. Then generate your project. This prepopulates your project with APIs and libraries that you can use to program your application.

The tool also supports easy development of multiple configurations and dynamic reconfiguration. Dynamic reconfiguration makes it possible to change configurations at run time. In essence, this allows you to use more than 100 percent of PSoC's resources for an application.

### *Code Generation Tools*

The code generation tools work seamlessly within the PSoC Designer interface and have been tested with a full range of debugging tools. You can develop your design in C, assembly, or a combination of the two.

**Assemblers.** The assemblers allow you to merge assembly code seamlessly with C code. Link libraries automatically use absolute addressing or are compiled in relative mode, and are linked with other software modules to get absolute addressing.

**C Language Compilers.** C language compilers are available that support the PSoC family of devices. The products allow you to create complete C programs for the PSoC family devices. The optimizing C compilers provide all of the features of C, tailored to the PSoC architecture. They come complete with embedded libraries providing port and bus operations, standard keypad and display support, and extended math functionality.

### *Debugger*

PSoC Designer has a debug environment that provides hardware in-circuit emulation, allowing you to test the program in a physical system while providing an internal view of the PSoC device. Debugger commands allow you to read and program and read and write data memory, and read and write I/O registers. You can read and write CPU registers, set and clear breakpoints, and provide program run, halt, and step control. The debugger also allows you to create a trace buffer of registers and memory locations of interest.

### *Online Help System*

The online help system displays online, context-sensitive help. Designed for procedural and quick reference, each functional subsystem has its own context-sensitive help. This system also provides tutorials and links to FAQs and an online support Forum to aid the designer.

### *In-Circuit Emulator*

A low-cost, high-functionality in-circuit emulator (ICE) is available for development support. This hardware can program single devices.

The emulator consists of a base unit that connects to the PC using a USB port. The base unit is universal and operates with all PSoC devices. Emulation pods for each device family are available separately. The emulation pod takes the place of the PSoC device in the target board and performs full-speed (24 MHz) operation.

## Designing with PSoC Designer

The development process for the PSoC device differs from that of a traditional fixed function microprocessor. The configurable analog and digital hardware blocks give the PSoC architecture a unique flexibility that pays dividends in managing specification change during development and by lowering inventory costs. These configurable resources, called PSoC Blocks, have the ability to implement a wide variety of user-selectable functions. The PSoC development process is summarized in four steps:

1. Select [User Modules](#).
2. Configure User Modules.
3. Organize and Connect.
4. Generate, Verify, and Debug.

### Select User Modules

PSoC Designer provides a library of prebuilt, pretested hardware peripheral components called “user modules.” User modules make selecting and implementing peripheral devices, both analog and digital, simple.

### Configure User Modules

Each user module that you select establishes the basic register settings that implement the selected function. They also provide parameters and properties that allow you to tailor their precise configuration to your particular application. For example, a PWM User Module configures one or more digital PSoC blocks, one for each 8 bits of resolution. The user module parameters permit you to establish the pulse width and duty cycle. Configure the parameters and properties to correspond to your chosen application. Enter values directly or by selecting values from drop-down menus. All the user modules are documented in datasheets that may be viewed directly in PSoC Designer or on the Cypress website. These [user module datasheets](#) explain the internal operation of the user module and provide performance specifications. Each datasheet describes the use of each user

module parameter, and other information you may need to successfully implement your design.

### Organize and Connect

You build signal chains at the chip level by interconnecting user modules to each other and the I/O pins. You perform the selection, configuration, and routing so that you have complete control over all on-chip resources.

### Generate, Verify, and Debug

When you are ready to test the hardware configuration or move on to developing code for the project, you perform the “Generate Configuration Files” step. This causes PSoC Designer to generate source code that automatically configures the device to your specification and provides the software for the system. The generated code provides application programming interfaces (APIs) with high-level functions to control and respond to hardware events at run-time and interrupt service routines that you can adapt as needed.

A complete code development environment allows you to develop and customize your applications in either C, assembly language, or both.

The last step in the development process takes place inside PSoC Designer’s debugger (access by clicking the Connect icon). PSoC Designer downloads the HEX image to the ICE where it runs at full speed. PSoC Designer debugging capabilities rival those of systems costing many times more. In addition to traditional single-step, run-to-breakpoint, and watch-variable features, the debug interface provides a large trace buffer and allows you to define complex breakpoint events. These include monitoring address and data bus values, memory locations, and external signals.

## Document Conventions

### Acronyms Used

The following table lists the acronyms that are used in this document.

**Table 2. Acronyms**

Acronym	Description
AC	alternating current
ADC	analog-to-digital converter
API	application programming interface
CPU	central processing unit
CT	continuous time
DAC	digital-to-analog converter
DC	direct current
ECO	external crystal oscillator
EEPROM	electrically erasable programmable read-only memory
FSR	full scale range
GPIO	general purpose I/O
GUI	graphical user interface
HBM	human body model
ICE	in-circuit emulator
ILO	internal low speed oscillator
IMO	internal main oscillator
I/O	input/output
IPOR	imprecise power on reset
LSb	least-significant bit
LVD	low voltage detect
MSb	most-significant bit
PC	program counter
PLL	phase-locked loop
POR	power on reset
PPOR	precision power on reset
PSoC®	Programmable System-on-Chip
PWM	pulse width modulator
SC	switched capacitor
SRAM	static random access memory

### Units of Measure

A units of measure table is located in the Electrical Specifications section. [Table 8](#) on page 14 lists all the abbreviations used to measure the PSoC devices.

### Numeric Naming

Hexadecimal numbers are represented with all letters in uppercase with an appended lowercase 'h' (for example, '14h' or '3Ah'). Hexadecimal numbers may also be represented by a '0x' prefix, the C coding convention. Binary numbers have an appended lowercase 'b' (for example, '01010100b' or '01000011b'). Numbers not indicated by an 'h', 'b', or '0x' are decimal.

## Pinouts

The automotive CY8C24x23A PSoC device is available in a variety of packages which are listed and illustrated in the following tables. Every port pin (labeled with a “P”) is capable of Digital I/O. However, Vss, Vdd, and XRES are not capable of Digital I/O.

### 20-Pin Part Pinout

**Table 3. 20-Pin Part Pinout (SSOP)**

Pin No.	Type		Pin Name	Description
	Digital	Analog		
1	I/O	I	P0[7]	Analog column mux input
2	I/O	I/O	P0[5]	Analog column mux input and column output
3	I/O	I/O	P0[3]	Analog column mux input and column output
4	I/O	I	P0[1]	Analog column mux input
5	Power		Vss	Ground connection
6	I/O		P1[7]	I <sup>2</sup> C Serial Clock (SCL)
7	I/O		P1[5]	I <sup>2</sup> C Serial Data (SDA)
8	I/O		P1[3]	
9	I/O		P1[1]	Crystal Input (XTALin), I <sup>2</sup> C Serial Clock (SCL), ISSP-SCLK <sup>[5]</sup>
10	Power		Vss	Ground connection
11	I/O		P1[0]	Crystal Output (XTALout), I <sup>2</sup> C Serial Data (SDA), ISSP-SDATA <sup>[5]</sup>
12	I/O		P1[2]	
13	I/O		P1[4]	Optional External Clock Input (EXTCLK)
14	I/O		P1[6]	
15	Input		XRES	Active high external reset with internal pull down
16	I/O	I	P0[0]	Analog column mux input
17	I/O	I	P0[2]	Analog column mux input
18	I/O	I	P0[4]	Analog column mux input
19	I/O	I	P0[6]	Analog column mux input
20	Power		Vdd	Supply voltage

**LEGEND:** A = Analog, I = Input, and O = Output.

**Figure 3. CY8C24223A 20-Pin PSoC Device**

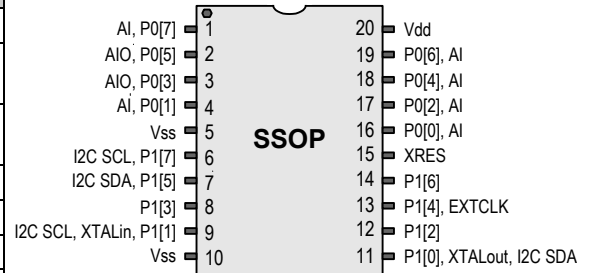

**Note**

5. These are the ISSP pins, which are not High Z when coming out of POR (Power On Reset). See the *PSoC Technical Reference Manual* for details.

## 28-Pin Part Pinout

**Table 4. 28-Pin Part Pinout (SSOP)**

Pin No.	Type		Pin Name	Description
	Digital	Analog		
1	I/O	I	P0[7]	Analog column mux input
2	I/O	I/O	P0[5]	Analog column mux input and column output
3	I/O	I/O	P0[3]	Analog column mux input and column output
4	I/O	I	P0[1]	Analog column mux input
5	I/O		P2[7]	
6	I/O		P2[5]	
7	I/O	I	P2[3]	Direct switched capacitor block input
8	I/O	I	P2[1]	Direct switched capacitor block input
9	Power		Vss	Ground connection
10	I/O		P1[7]	I <sup>2</sup> C Serial Clock (SCL)
11	I/O		P1[5]	I <sup>2</sup> C Serial Data (SDA)
12	I/O		P1[3]	
13	I/O		P1[1]	Crystal Input (XTALin), I <sup>2</sup> C Serial Clock (SCL), ISSP-SCLK <sup>[5]</sup>
14	Power		Vss	Ground connection
15	I/O		P1[0]	Crystal Output (XTALout), I <sup>2</sup> C Serial Data (SDA), ISSP-SDATA <sup>[5]</sup>
16	I/O		P1[2]	
17	I/O		P1[4]	Optional External Clock Input (EXTCLK)
18	I/O		P1[6]	
19	Input		XRES	Active high external reset with internal pull down
20	I/O	I	P2[0]	Direct switched capacitor block input
21	I/O	I	P2[2]	Direct switched capacitor block input
22	I/O		P2[4]	External Analog Ground (AGND)
23	I/O		P2[6]	External Voltage Reference (VRef)
24	I/O	I	P0[0]	Analog column mux input
25	I/O	I	P0[2]	Analog column mux input
26	I/O	I	P0[4]	Analog column mux input
27	I/O	I	P0[6]	Analog column mux input
28	Power		Vdd	Supply voltage

**LEGEND:** A = Analog, I = Input, and O = Output.

**Figure 4. CY8C24423A 28-Pin PSoC Device**

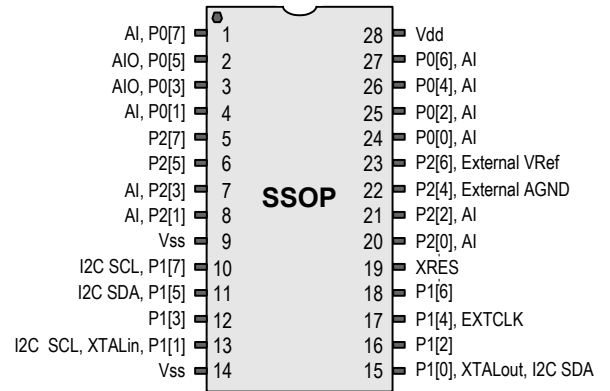

## Registers

### Register Conventions

This section lists the registers of the automotive CY8C24x23A PSoC device. For detailed register information, refer to the [PSoC Technical Reference Manual](#).

The register conventions specific to this section are listed in the following table.

**Table 5. Abbreviations**

Convention	Description
R	Read register or bit(s)
W	Write register or bit(s)
L	Logical register or bit(s)
C	Clearable register or bit(s)
#	Access is bit specific

### Register Mapping Tables

The PSoC device has a total register address space of 512 bytes. The register space is referred to as I/O space and is divided into two banks. The XIO bit in the Flag register (CPU\_F) determines which bank the user is currently in. When the XIO bit is set the user is in Bank 1.

**Note** In the following register mapping tables, blank fields are Reserved and must not be accessed.

**Table 6. Register Map Bank 0 Table: User Space**

Name	Addr (0,Hex)	Access	Name	Addr (0,Hex)	Access	Name	Addr (0,Hex)	Access	Name	Addr (0,Hex)	Access
PRT0DR	00	RW		40		ASC10CR0	80	RW		C0	
PRT0IE	01	RW		41		ASC10CR1	81	RW		C1	
PRT0GS	02	RW		42		ASC10CR2	82	RW		C2	
PRT0DM2	03	RW		43		ASC10CR3	83	RW		C3	
PRT1DR	04	RW		44		ASD11CR0	84	RW		C4	
PRT1IE	05	RW		45		ASD11CR1	85	RW		C5	
PRT1GS	06	RW		46		ASD11CR2	86	RW		C6	
PRT1DM2	07	RW		47		ASD11CR3	87	RW		C7	
PRT2DR	08	RW		48			88			C8	
PRT2IE	09	RW		49			89			C9	
PRT2GS	0A	RW		4A			8A			CA	
PRT2DM2	0B	RW		4B			8B			CB	
	0C			4C			8C			CC	
	0D			4D			8D			CD	
	0E			4E			8E			CE	
	0F			4F			8F			CF	
	10			50		ASD20CR0	90	RW		D0	
	11			51		ASD20CR1	91	RW		D1	
	12			52		ASD20CR2	92	RW		D2	
	13			53		ASD20CR3	93	RW		D3	
	14			54		ASC21CR0	94	RW		D4	
	15			55		ASC21CR1	95	RW		D5	
	16			56		ASC21CR2	96	RW	I2C_CFG	D6	RW
	17			57		ASC21CR3	97	RW	I2C_SCR	D7	#
	18			58			98		I2C_DR	D8	RW
	19			59			99		I2C_MSCR	D9	#
	1A			5A			9A		INT_CLR0	DA	RW
	1B			5B			9B		INT_CLR1	DB	RW
	1C			5C			9C			DC	
	1D			5D			9D		INT_CLR3	DD	RW
	1E			5E			9E		INT_MSK3	DE	RW
	1F			5F			9F			DF	
DBB00DR0	20	#	AMX_IN	60	RW		A0		INT_MSK0	E0	RW
DBB00DR1	21	W		61			A1		INT_MSK1	E1	RW
DBB00DR2	22	RW		62			A2		INT_VC	E2	RC
DBB00CR0	23	#	ARF_CR	63	RW		A3		RES_WDT	E3	W
DBB01DR0	24	#	CMP_CR0	64	#		A4		DEC_DH	E4	RC
DBB01DR1	25	W	ASY_CR	65	#		A5		DEC_DL	E5	RC
DBB01DR2	26	RW	CMP_CR1	66	RW		A6		DEC_CR0	E6	RW
DBB01CR0	27	#		67			A7		DEC_CR1	E7	RW
DCB02DR0	28	#		68			A8		MUL_X	E8	W
DCB02DR1	29	W		69			A9		MUL_Y	E9	W
DCB02DR2	2A	RW		6A			AA		MUL_DH	EA	R
DCB02CR0	2B	#		6B			AB		MUL_DL	EB	R
DCB03DR0	2C	#		6C			AC		ACC_DR1	EC	RW
DCB03DR1	2D	W		6D			AD		ACC_DR0	ED	RW
DCB03DR2	2E	RW		6E			AE		ACC_DR3	EE	RW
DCB03CR0	2F	#		6F			AF		ACC_DR2	EF	RW
	30		ACB00CR3	70	RW	RDI0RI	B0	RW		F0	
	31		ACB00CR0	71	RW	RDI0SYN	B1	RW		F1	
	32		ACB00CR1	72	RW	RDI0IS	B2	RW		F2	
	33		ACB00CR2	73	RW	RDI0LT0	B3	RW		F3	
	34		ACB01CR3	74	RW	RDI0LT1	B4	RW		F4	
	35		ACB01CR0	75	RW	RDI0RO0	B5	RW		F5	
	36		ACB01CR1	76	RW	RDI0RO1	B6	RW		F6	
	37		ACB01CR2	77	RW		B7		CPU_F	F7	RL
	38			78			B8			F8	
	39			79			B9			F9	
	3A			7A			BA			FA	
	3B			7B			BB			FB	
	3C			7C			BC			FC	
	3D			7D			BD			FD	
	3E			7E			BE		CPU_SCR1	FE	#
	3F			7F			BF		CPU_SCR0	FF	#

Blank fields are Reserved and must not be accessed.

# Access is bit specific.

Table 7. Register Map Bank 1 Table: Configuration Space

Name	Addr (1,Hex)	Access	Name	Addr (1,Hex)	Access	Name	Addr (1,Hex)	Access	Name	Addr (1,Hex)	Access
PRT0DM0	00	RW		40		ASC10CR0	80	RW		C0	
PRT0DM1	01	RW		41		ASC10CR1	81	RW		C1	
PRT0IC0	02	RW		42		ASC10CR2	82	RW		C2	
PRT0IC1	03	RW		43		ASC10CR3	83	RW		C3	
PRT1DM0	04	RW		44		ASD11CR0	84	RW		C4	
PRT1DM1	05	RW		45		ASD11CR1	85	RW		C5	
PRT1IC0	06	RW		46		ASD11CR2	86	RW		C6	
PRT1IC1	07	RW		47		ASD11CR3	87	RW		C7	
PRT2DM0	08	RW		48			88			C8	
PRT2DM1	09	RW		49			89			C9	
PRT2IC0	0A	RW		4A			8A			CA	
PRT2IC1	0B	RW		4B			8B			CB	
	0C			4C			8C			CC	
	0D			4D			8D			CD	
	0E			4E			8E			CE	
	0F			4F			8F			CF	
	10			50		ASD20CR0	90	RW	GDI_O_IN	D0	RW
	11			51		ASD20CR1	91	RW	GDI_E_IN	D1	RW
	12			52		ASD20CR2	92	RW	GDI_O_OU	D2	RW
	13			53		ASD20CR3	93	RW	GDI_E_OU	D3	RW
	14			54		ASC21CR0	94	RW		D4	
	15			55		ASC21CR1	95	RW		D5	
	16			56		ASC21CR2	96	RW		D6	
	17			57		ASC21CR3	97	RW		D7	
	18			58			98			D8	
	19			59			99			D9	
	1A			5A			9A			DA	
	1B			5B			9B			DB	
	1C			5C			9C			DC	
	1D			5D			9D		OSC_GO_EN	DD	RW
	1E			5E			9E		OSC_CR4	DE	RW
	1F			5F			9F		OSC_CR3	DF	RW
DBB00FN	20	RW	CLK_CR0	60	RW		A0		OSC_CR0	E0	RW
DBB00IN	21	RW	CLK_CR1	61	RW		A1		OSC_CR1	E1	RW
DBB00OU	22	RW	ABF_CR0	62	RW		A2		OSC_CR2	E2	RW
	23		AMD_CR0	63	RW		A3		VLT_CR	E3	RW
DBB01FN	24	RW		64			A4		VLT_CMP	E4	R
DBB01IN	25	RW		65			A5			E5	
DBB01OU	26	RW	AMD_CR1	66	RW		A6			E6	
	27		ALT_CR0	67	RW		A7			E7	
DCB02FN	28	RW		68			A8		IMO_TR	E8	W
DCB02IN	29	RW		69			A9		ILO_TR	E9	W
DCB02OU	2A	RW		6A			AA		BDG_TR	EA	RW
	2B			6B			AB		ECO_TR	EB	W
DCB03FN	2C	RW		6C			AC			EC	
DCB03IN	2D	RW		6D			AD			ED	
DCB03OU	2E	RW		6E			AE			EE	
	2F			6F			AF			EF	
	30		ACB00CR3	70	RW	RDI0RI	B0	RW		F0	
	31		ACB00CR0	71	RW	RDI0SYN	B1	RW		F1	
	32		ACB00CR1	72	RW	RDI0IS	B2	RW		F2	
	33		ACB00CR2	73	RW	RDI0LT0	B3	RW		F3	
	34		ACB01CR3	74	RW	RDI0LT1	B4	RW		F4	
	35		ACB01CR0	75	RW	RDI0RO0	B5	RW		F5	
	36		ACB01CR1	76	RW	RDI0RO1	B6	RW		F6	
	37		ACB01CR2	77	RW		B7		CPU_F	F7	RL
	38			78			B8			F8	
	39			79			B9			F9	
	3A			7A			BA			FA	
	3B			7B			BB			FB	
	3C			7C			BC			FC	
	3D			7D			BD			FD	
	3E			7E			BE		CPU_SCR1	FE	#
	3F			7F			BF		CPU_SCR0	FF	#

Blank fields are Reserved and must not be accessed.

# Access is bit specific.

## Electrical Specifications

This section presents the DC and AC electrical specifications of the automotive CY8C24x23A PSoC device. For the latest electrical specifications, visit <http://www.cypress.com>.

Specifications are valid for  $-40^{\circ}\text{C} \leq T_A \leq 125^{\circ}\text{C}$  and  $T_J \leq 135^{\circ}\text{C}$ , except where noted.

Figure 5. Voltage versus CPU Frequency

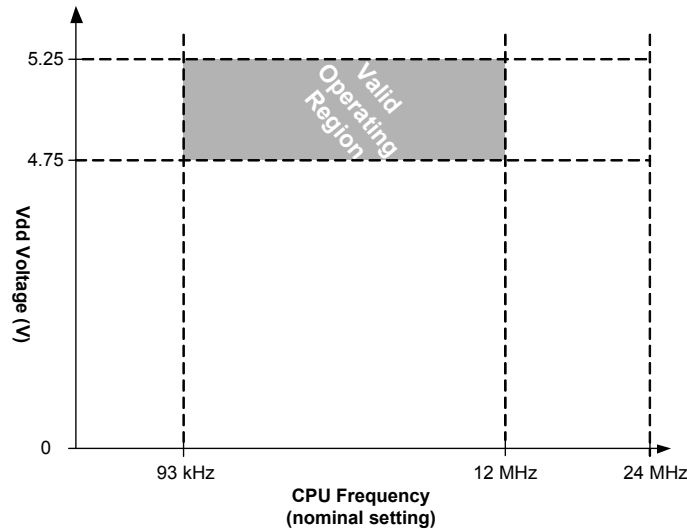

The following table lists the units of measure that are used in this section.

Table 8. Units of Measure

Symbol	Unit of Measure	Symbol	Unit of Measure
°C	degree Celsius	μVrms	microvolts root-mean-square
dB	decibels	μW	microwatts
fF	femto farad	mA	milli-ampere
Hz	hertz	ms	milli-second
KB	1024 bytes	mV	milli-volts
Kbit	1024 bits	nA	nanoampere
kHz	kilohertz	ns	nanosecond
kΩ	kilohm	nV	nanovolts
Mbaud	megabaud	Ω	ohm
Mbps	megabits per second	pA	picoampere
MHz	megahertz	pF	picofarad
MΩ	megaohm	pp	peak-to-peak
μA	microampere	ppm	parts per million
μF	microfarad	ps	picosecond
μH	microhenry	sps	samples per second
μs	microsecond	σ	sigma: one standard deviation
μV	microvolts	V	volts

## Absolute Maximum Ratings

Exceeding maximum ratings may shorten the useful life of the device. User guidelines are not tested.

**Table 9. Absolute Maximum Ratings**

Symbol	Description	Min	Typ	Max	Units	Notes
T <sub>STG</sub>	Storage Temperature	-55	+25	+125	°C	Higher storage temperatures reduce data retention time. Recommended storage temperature is +25°C ± 25°C. Storage temperatures above 65°C degrades reliability. Maximum combined storage and operational time at +125°C is 7000 hours.
T <sub>BAKETEMP</sub>	Bake Temperature	–	125	See package label	°C	
T <sub>BAKETIME</sub>	Bake Time	See package label	–	72	Hours	
T <sub>A</sub>	Ambient Temperature with Power Applied	-40	–	+125	°C	
V <sub>DD</sub>	Supply Voltage on V <sub>DD</sub> Relative to V <sub>SS</sub>	-0.5	–	+6.0	V	
V <sub>IO</sub>	DC Input Voltage	V <sub>SS</sub> - 0.5	–	V <sub>DD</sub> + 0.5	V	
V <sub>IOZ</sub>	DC Voltage Applied to Tri-state	V <sub>SS</sub> - 0.5	–	V <sub>DD</sub> + 0.5	V	
I <sub>MIO</sub>	Maximum Current into any Port Pin	-25	–	+25	mA	
ESD	Electro Static Discharge Voltage	2000	–	–	V	Human Body Model ESD.
LU	Latch up Current	–	–	200	mA	

## Operating Temperature

**Table 10. Operating Temperature**

Symbol	Description	Min	Typ	Max	Units	Notes
T <sub>A</sub>	Ambient Temperature	-40	–	+125	°C	
T <sub>J</sub>	Junction Temperature	-40	–	+135	°C	The temperature rise from ambient to junction is package specific. See <a href="#">Thermal Impedances</a> on page 29. The user must limit the power consumption to comply with this requirement.

**DC Electrical Characteristics**
*DC Chip-Level Specifications*

The following table lists guaranteed maximum and minimum specifications for the voltage and temperature ranges: 4.75V to 5.25V and  $-40^{\circ}\text{C} \leq T_A \leq 125^{\circ}\text{C}$ . Typical parameters apply to 5V at  $25^{\circ}\text{C}$  and are for design guidance only.

**Table 11. DC Chip-Level Specifications**

Symbol	Description	Min	Typ	Max	Units	Notes
V <sub>DD</sub>	Supply Voltage	4.75	–	5.25	V	See table titled <a href="#">DC POR and LVD Specifications</a> on page 20
I <sub>DD</sub>	Supply Current	–	5	8	mA	Conditions are V <sub>DD</sub> = 5.25V, $-40^{\circ}\text{C} \leq T_A \leq 125^{\circ}\text{C}$ , CPU = 3 MHz, 48 MHz disabled, VC1 = 1.5 MHz, VC2 = 93.75 kHz, VC3 = 93.75 kHz, Analog power = off.
I <sub>SB</sub>	Sleep (Mode) Current with POR, LVD, Sleep Timer, and WDT. <sup>[6]</sup>	–	4	13	μA	Conditions are with internal low speed oscillator active, V <sub>DD</sub> = 5.25V, $-40^{\circ}\text{C} \leq T_A \leq 55^{\circ}\text{C}$ . Analog power = off.
I <sub>SBH</sub>	Sleep (Mode) Current with POR, LVD, Sleep Timer, and WDT at high temperature. <sup>[6]</sup>	–	4	100	μA	Conditions are with internal slow speed oscillator active, V <sub>DD</sub> = 5.25V, $55^{\circ}\text{C} < T_A \leq 125^{\circ}\text{C}$ . Analog power = off.
I <sub>SBXTL</sub>	Sleep (Mode) Current with POR, LVD, Sleep Timer, WDT, and external crystal. <sup>[6]</sup>	–	6	15	μA	Conditions are with properly loaded, 1 μW max, 32.768 kHz crystal. V <sub>DD</sub> = 5.25V, $-40^{\circ}\text{C} \leq T_A \leq 55^{\circ}\text{C}$ . Analog power = off.
I <sub>SBXTLH</sub>	Sleep (Mode) Current with POR, LVD, Sleep Timer, WDT, and external crystal at high temperature. <sup>[6]</sup>	–	6	100	μA	Conditions are with properly loaded, 1 μW max, 32.768 kHz crystal. V <sub>DD</sub> = 5.25V, $55^{\circ}\text{C} < T_A \leq 125^{\circ}\text{C}$ . Analog power = off.
V <sub>REF</sub>	Reference Voltage (Bandgap)	1.25	1.3	1.35	V	Trimmed for appropriate V <sub>DD</sub> .

*DC General Purpose I/O Specifications*

The following tables list guaranteed maximum and minimum specifications for the voltage and temperature ranges: 4.75V to 5.25V and  $-40^{\circ}\text{C} \leq T_A \leq 125^{\circ}\text{C}$ . Typical parameters apply to 5V at  $25^{\circ}\text{C}$  and are for design guidance.

**Table 12. DC GPIO Specifications**

Symbol	Description	Min	Typ	Max	Units	Notes
R <sub>PU</sub>	Pull up Resistor	4	5.6	8	kΩ	
R <sub>PD</sub>	Pull down Resistor	4	5.6	8	kΩ	
V <sub>OH</sub>	High Output Level	3.5	–	–	V	I <sub>OH</sub> = 10 mA, V <sub>DD</sub> = 4.75 to 5.25V (maximum 40 mA on even port pins (for example, P0[2], P1[4]), maximum 40 mA on odd port pins (for example, P0[3], P1[5])). 80 mA maximum combined I <sub>OH</sub> budget.
V <sub>OL</sub>	Low Output Level	–	–	0.75	V	I <sub>OL</sub> = 25 mA, V <sub>DD</sub> = 4.75 to 5.25V (maximum 100 mA on even port pins (for example, P0[2], P1[4]), maximum 100 mA on odd port pins (for example, P0[3], P1[5])). 150 mA maximum combined I <sub>OL</sub> budget.
I <sub>OH</sub>	High Level Source Current	10	–	–	mA	V <sub>OH</sub> ≥ V <sub>DD</sub> -1.0V, see the limitations of the total current in the note for V <sub>OH</sub> .
I <sub>OL</sub>	Low Level Sink Current	25	–	–	mA	V <sub>OL</sub> ≤ 0.75V, see the limitations of the total current in the note for V <sub>OL</sub> .
V <sub>IL</sub>	Input Low Level	–	–	0.8	V	

**Note**

6. Standby current includes all functions (POR, LVD, WDT, Sleep Timer) needed for reliable system operation. This must be compared with devices that have similar functions enabled.

**Table 12. DC GPIO Specifications (continued)**

Symbol	Description	Min	Typ	Max	Units	Notes
V <sub>IH</sub>	Input High Level	2.1	–		V	
V <sub>H</sub>	Input Hysteresis	–	60	–	mV	
I <sub>IL</sub>	Input Leakage (Absolute Value)	–	1	–	nA	Gross tested to 1 μA
C <sub>IN</sub>	Capacitive Load on Pins as Input	–	3.5	10	pF	Package and pin dependent. Temp = 25°C
C <sub>OUT</sub>	Capacitive Load on Pins as Output	–	3.5	10	pF	Package and pin dependent. Temp = 25°C

**DC Operational Amplifier Specifications**

The following tables list guaranteed maximum and minimum specifications for the voltage and temperature ranges: 4.75V to 5.25V and  $-40^{\circ}\text{C} \leq T_A \leq 125^{\circ}\text{C}$ . Typical parameters apply to 5V at 25°C and are for design guidance only.

The Operational Amplifier is a component of both the Analog Continuous Time (CT) PSoC blocks and the Analog Switched Capacitor (SC) PSoC blocks. The guaranteed specifications are measured in the Analog Continuous Time (CT) PSoC blocks.

**Table 13. DC Operational Amplifier Specifications**

Symbol	Description	Min	Typ	Max	Units	Notes
V <sub>OSOA</sub>	Input Offset Voltage (absolute value) Low Power Input Offset Voltage (absolute value) Mid Power Input Offset Voltage (absolute value) High Power	–	1.6 1.3 1.2	11 9 9	mV mV mV	
TCV <sub>OSOA</sub>	Input Offset Voltage Drift	–	7.0	35.0	μV/°C	
I <sub>EBOA</sub>	Input Leakage Current (Port 0 Analog Pins)	–	200	–	pA	Gross tested to 1 μA
C <sub>INOA</sub>	Input Capacitance (Port 0 Analog Pins)	–	4.5	9.5	pF	Package and pin dependent. Temp = 25°C.
V <sub>CMOA</sub>	Common Mode Voltage Range Common Mode Voltage Range (high power or high opamp bias)	0.0 0.5	– –	V <sub>DD</sub> V <sub>DD</sub> - 0.5	V –	The common-mode input voltage range is measured through an analog output buffer. The specification includes the limitations imposed by the characteristics of the analog output buffer.
G <sub>OLOA</sub>	Open Loop Gain Power = Low Power = Medium Power = High	– – –	80 80 80	– – –	dB dB dB	Specification is applicable at high power. For all other bias modes (except high power, high opamp bias), minimum is 60 dB.
V <sub>OHIGHOA</sub>	High Output Voltage Swing (worst case internal load) Power = Low Power = Medium Power = High	V <sub>DD</sub> - 0.2 V <sub>DD</sub> - 0.2 V <sub>DD</sub> - 0.5	– – –	– – –	V V V	
V <sub>OLOWOA</sub>	Low Output Voltage Swing (worst case internal load) Power = Low Power = Medium Power = High	– – –	– – –	0.2 0.2 0.5	V V V	
I <sub>SOA</sub>	Supply Current (including associated AGND buffer) Power = Low, Opamp Bias = Low Power = Low, Opamp Bias = High Power = Medium, Opamp Bias = Low Power = Medium, Opamp Bias = High Power = High, Opamp Bias = Low Power = High, Opamp Bias = High	– – – – – –	150 300 600 1200 2400 4600	200 400 800 1600 3200 6400	μA μA μA μA μA μA	
PSRR <sub>OA</sub>	Supply Voltage Rejection Ratio	–	80	–	dB	V <sub>SS</sub> ≤ VIN ≤ (V <sub>DD</sub> - 2.25) or (V <sub>DD</sub> - 1.25V) ≤ VIN ≤ V <sub>DD</sub>

**DC Low Power Comparator Specifications**

The following tables list guaranteed maximum and minimum specifications for the voltage and temperature ranges: 4.75V to 5.25V and  $-40^{\circ}\text{C} \leq T_A \leq 125^{\circ}\text{C}$ . Typical parameters apply to 5V at  $25^{\circ}\text{C}$  and are for design guidance only.

**Table 14. DC Low Power Comparator Specifications**

Symbol	Description	Min	Typ	Max	Units	Notes
$V_{\text{REFLPC}}$	Low power comparator (LPC) reference voltage range	0.2	–	$V_{\text{dd}} - 1$	V	
$I_{\text{SLPC}}$	LPC supply current	–	10	40	$\mu\text{A}$	
$V_{\text{OSLPC}}$	LPC voltage offset	–	2.5	30	mV	

**DC Analog Output Buffer Specifications**

The following tables list guaranteed maximum and minimum specifications for the voltage and temperature ranges: 4.75V to 5.25V and  $-40^{\circ}\text{C} \leq T_A \leq 125^{\circ}\text{C}$ . Typical parameters apply to 5V at  $25^{\circ}\text{C}$  and are for design guidance only.

**Table 15. DC Analog Output Buffer Specifications**

Symbol	Description	Min	Typ	Max	Units	Notes
$V_{\text{OSOB}}$	Input Offset Voltage (Absolute Value)	–	3	18	mV	
$\text{TCV}_{\text{OSOB}}$	Input Offset Voltage Drift	–	+6	–	$\mu\text{V}/^{\circ}\text{C}$	
$V_{\text{CMOB}}$	Common-Mode Input Voltage Range	0.5	–	$V_{\text{dd}} - 1.0$	V	
$R_{\text{OUTOB}}$	Output Resistance	–	1	–	$\Omega$	
$V_{\text{OHIGHOB}}$	High Output Voltage Swing (Load = $32\Omega$ to $V_{\text{dd}}/2$ )	$0.5 \times V_{\text{dd}}$ $+ 1.1$	–	–	V	
$V_{\text{OLOWOB}}$	Low Output Voltage Swing (Load = $32\Omega$ to $V_{\text{dd}}/2$ )	–	–	$0.5 \times V_{\text{dd}}$ $- 1.3$	V	
$I_{\text{SOB}}$	Supply Current Including Bias Cell (No Load)					
	Power = Low	–	1.1	5.1	mA	
	Power = High	–	2.6	8.8	mA	
$\text{PSRR}_{\text{OB}}$	Supply Voltage Rejection Ratio	–	64	–	dB	

### DC Analog Reference Specifications

The following tables list guaranteed maximum and minimum specifications for the voltage and temperature ranges: 4.75V to 5.25V and  $-40^{\circ}\text{C} \leq T_A \leq 125^{\circ}\text{C}$ . Typical parameters apply to 5V at 25°C and are for design guidance only.

The guaranteed specifications are measured through the Analog Continuous Time PSoC blocks. The power levels for AGND refer to the power of the Analog Continuous Time PSoC block. The power levels for RefHi and RefLo refer to the Analog Reference Control register. The limits stated for AGND include the offset error of the AGND buffer local to the Analog Continuous Time PSoC block.

**Note** Avoid using P2[4] for digital signaling when using an analog resource that depends on the Analog Reference. Some coupling of the digital signal may appear on the AGND.

**Table 16. DC Analog Reference Specifications**

Symbol	Description	Min	Typ	Max	Units
BG	Bandgap Voltage Reference	1.25	1.30	1.35	V
–	AGND = $V_{dd}/2$ <sup>[7]</sup>	$V_{dd}/2 - 0.02$	$V_{dd}/2$	$V_{dd}/2 + 0.02$	V
–	AGND = $2 \times \text{BandGap}$ <sup>[7]</sup>	2.4	2.6	2.8	V
–	AGND = P2[4] (P2[4] = $V_{dd}/2$ ) <sup>[7]</sup>	P2[4] - 0.02	P2[4]	P2[4] + 0.02	V
–	AGND = $\text{BandGap}$ <sup>[7]</sup>	1.23	1.30	1.37	V
–	AGND = $1.6 \times \text{BandGap}$ <sup>[7]</sup>	1.98	2.08	2.14	V
–	AGND Column to Column Variation (AGND = $V_{dd}/2$ ) <sup>[7]</sup>	-0.035	0.000	0.035	V
–	RefHi = $V_{dd}/2 + \text{BandGap}$ <sup>[8]</sup>	$V_{dd}/2 + 1.15$	$V_{dd}/2 + 1.30$	$V_{dd}/2 + 1.45$	V
–	RefHi = $3 \times \text{BandGap}$ <sup>[8]</sup>	3.65	3.9	4.15	V
–	RefHi = $2 \times \text{BandGap} + \text{P2}[6]$ (P2[6] = 1.3V) <sup>[8]</sup>	P2[6] + 2.4	P2[6] + 2.6	P2[6] + 2.8	V
–	RefHi = P2[4] + $\text{BandGap}$ (P2[4] = $V_{dd}/2$ ) <sup>[8]</sup>	P2[4] + 1.24	P2[4] + 1.30	P2[4] + 1.36	V
–	RefHi = P2[4] + P2[6] (P2[4] = $V_{dd}/2$ , P2[6] = 1.3V) <sup>[8]</sup>	P2[4] + P2[6] - 0.1	P2[4] + P2[6]	P2[4] + P2[6] + 0.1	V
–	RefHi = $3.2 \times \text{BandGap}$ <sup>[8]</sup>	3.9	4.16	4.42	V
–	RefLo = $V_{dd}/2 - \text{BandGap}$ <sup>[8]</sup>	$V_{dd}/2 - 1.45$	$V_{dd}/2 - 1.3$	1.15	V
–	RefLo = $\text{BandGap}$ <sup>[8]</sup>	1.15	1.3	1.45	V
–	RefLo = $2 \times \text{BandGap} - \text{P2}[6]$ (P2[6] = 1.3V) <sup>[8]</sup>	2.4 - P2[6]	2.6 - P2[6]	2.8 - P2[6]	V
–	RefLo = P2[4] - $\text{BandGap}$ (P2[4] = $V_{dd}/2$ ) <sup>[8]</sup>	P2[4] - 1.45	1.3	P2[4] - 1.15	V
–	RefLo = P2[4] - P2[6] (P2[4] = $V_{dd}/2$ , P2[6] = 1.3V) <sup>[8]</sup>	P2[4] - P2[6] - 0.1	P2[4] - P2[6]	P2[4] - P2[6] + 0.1	V

**Notes**

7. This specification is only valid when CT Block Power = High. AGND tolerance includes the offsets of the local buffer in the PSoC block. Bandgap voltage is  $1.3V \pm 0.05V$ .
8. This specification is only valid when Ref Control Power = High.

### DC Analog PSoC Block Specifications

The following table lists guaranteed maximum and minimum specifications for the voltage and temperature ranges: 4.75V to 5.25V and  $-40^{\circ}\text{C} \leq T_A \leq 125^{\circ}\text{C}$ . Typical parameters apply to 5V at  $25^{\circ}\text{C}$  and are for design guidance only.

**Table 17. DC Analog PSoC Block Specifications**

Symbol	Description	Min	Typ	Max	Units	Notes
$R_{CT}$	Resistor Unit Value (Continuous Time)	–	12.24	–	$k\Omega$	
$C_{SC}$	Capacitor Unit Value (Switch Cap)	–	80	–	fF	

### DC POR and LVD Specifications

The following table lists guaranteed maximum and minimum specifications for the voltage and temperature ranges: 4.75V to 5.25V and  $-40^{\circ}\text{C} \leq T_A \leq 125^{\circ}\text{C}$ . Typical parameters apply to 5V at  $25^{\circ}\text{C}$  and are for design guidance only.

**Note** The bits PORLEV and VM in the following table refer to bits in the VLT\_CR register. See the *PSoC Technical Reference Manual* for more information on the VLT\_CR register.

**Table 18. DC POR and LVD Specifications**

Symbol	Description	Min	Typ	Max	Units	Notes
$V_{PPOR2}$	Vdd Value for PPOR Trip PORLEV[1:0] = 10b	–	4.55	4.70	V	Vdd must be greater than or equal to 2.5V during startup, reset from the XRES pin, or reset from watchdog.
$V_{LVD6}$ $V_{LVD7}$	Vdd Value for LVD Trip VM[2:0] = 110b VM[2:0] = 111b	4.62 4.710	4.73 4.814	4.83 4.950	V V	

### DC Programming Specifications

The following table lists guaranteed maximum and minimum specifications for the voltage and temperature ranges: 4.75V to 5.25V and  $-40^{\circ}\text{C} \leq T_A \leq 125^{\circ}\text{C}$ . Typical parameters apply to 5V at  $25^{\circ}\text{C}$  and are for design guidance only.

**Table 19. DC Programming Specifications**

Symbol	Description	Min	Typ	Max	Units	Notes
$V_{ddIWRITE}$	Supply Voltage for Flash Write Operations	4.75	–	–	V	
$I_{DDP}$	Supply Current During Programming or Verify	–	10	25	mA	
$V_{ILP}$	Input Low Voltage During Programming or Verify	–	–	0.8	V	
$V_{IHP}$	Input High Voltage During Programming or Verify	2.1	–	–	V	
$I_{ILP}$	Input Current when Applying $V_{ILP}$ to P1[0] or P1[1] During Programming or Verify	–	–	0.2	mA	Driving internal pull down resistor.
$I_{IHP}$	Input Current when Applying $V_{IHP}$ to P1[0] or P1[1] During Programming or Verify	–	–	1.5	mA	Driving internal pull down resistor.
$V_{OLV}$	Output Low Voltage During Programming or Verify	–	–	0.75	V	
$V_{OHV}$	Output High Voltage During Programming or Verify	3.5	–	Vdd	V	
$\text{Flash}_{ENPB}$	Flash Endurance (per block) <sup>[9]</sup>	100	–	–	–	Erase/write cycles per block.
$\text{Flash}_{ENT}$	Flash Endurance (total) <sup>[9, 10]</sup>	6,400	–	–	–	Erase/write cycles.
$\text{Flash}_{DR}$	Flash Data Retention <sup>[11]</sup>	15	–	–	Years	

#### Notes

- For the full temperature range, the user must employ a temperature sensor user module (FlashTemp) or other temperature sensor, and feed the result to the temperature argument before writing. Refer to the Flash APIs Application Note AN2015 at <http://www.cypress.com> under Application Notes for more information.
- The maximum total number of allowed erase/write cycles is the minimum  $\text{Flash}_{ENPB}$  value multiplied by the number of flash blocks in the device.
- Flash data retention based on the use condition of  $\leq 7000$  hours at  $T_A \leq 125^{\circ}\text{C}$  and the remaining time at  $T_A \leq 65^{\circ}\text{C}$ .

## AC Electrical Characteristics

### AC Chip-Level Specifications

The following tables list guaranteed maximum and minimum specifications for the voltage and temperature ranges: 4.75V to 5.25V and  $-40^{\circ}\text{C} \leq T_A \leq 125^{\circ}\text{C}$ . Typical parameters apply to 5V at 25°C and are for design guidance only.

**Table 20. AC Chip-Level Specifications**

Symbol	Description	Min	Typ	Max	Units	Notes
F <sub>IMO24</sub>	Internal Main Oscillator Frequency for 24 MHz	23.04 <sup>[12]</sup>	24	24.96 <sup>[12]</sup>	MHz	Trimmed using factory trim values.
F <sub>CPU1</sub>	CPU Frequency (5V V <sub>DD</sub> Nominal)	0.09 <sup>[12]</sup>	12	12.48 <sup>[12]</sup>	MHz	
F <sub>24M</sub>	Digital PSoC Block Frequency	0	24	24.96 <sup>[12, 13]</sup>	MHz	
F <sub>32K1</sub>	Internal Low Speed Oscillator Frequency	15	32	64	kHz	This specification applies when the ILO has been trimmed.
F <sub>32KU</sub>	Internal Low Speed Oscillator (ILO) Untrimmed Frequency	5	–	–	kHz	After a reset and before the M8C processor starts to execute, the ILO is not trimmed.
F <sub>32K2</sub>	External Crystal Oscillator	–	32.768	–	kHz	Accuracy is capacitor and crystal dependent. 50% duty cycle.
F <sub>PLL</sub>	PLL Frequency	–	23.986	–	MHz	A multiple (x732) of crystal frequency.
Jitter24M2	24 MHz Period Jitter (PLL)	–	–	800	ps	Refer to <a href="#">Figure 9</a> on page 22.
T <sub>PLLSLEW</sub>	PLL Lock Time	0.5	–	10	ms	Refer to <a href="#">Figure 6</a> on page 22.
T <sub>PLLSLEWSLOW</sub>	PLL Lock Time for Low Gain Setting	0.5	–	50	ms	Refer to <a href="#">Figure 7</a> on page 22.
T <sub>OS</sub>	External Crystal Oscillator Startup to 1%	–	1700	2620	ms	Refer to <a href="#">Figure 8</a> on page 22.
T <sub>OSACC</sub>	External Crystal Oscillator Startup to 100 ppm	–	2800	3800	ms	
Jitter32k	32 kHz Period Jitter	–	100	–	ns	Refer to <a href="#">Figure 10</a> on page 22.
T <sub>XRST</sub>	External Reset Pulse Width	10	–	–	μs	
DC <sub>24M</sub>	24 MHz Duty Cycle	40	50	60	%	
DC <sub>ILO</sub>	Internal Low Speed Oscillator (ILO) Duty Cycle	20	50	80	%	
Step24M	24 MHz Trim Step Size	–	50	–	kHz	
Jitter24M1P	24 MHz Period Jitter (IMO) Peak-to-Peak	–	600	–	ps	Refer to <a href="#">Figure 9</a> on page 22.
Jitter24M1R	24 MHz Period Jitter (IMO) Root Mean Squared	–	–	600	ps	
F <sub>MAX</sub>	Maximum frequency of signal on row input or row output.	–	–	12.48 <sup>[12]</sup>	MHz	
SR <sub>POWERUP</sub>	Power Supply Slew Rate	–	–	250	V/ms	V <sub>DD</sub> slew rate during power up.
T <sub>POWERUP</sub>	Time between end of POR state and CPU code execution	–	16	100	ms	Power up from 0V.

#### Notes

12. Accuracy derived from Internal Main Oscillator with appropriate trim for V<sub>DD</sub> range.

13. See the individual user module data sheets for information on maximum frequencies for user modules.

**Figure 6. PLL Lock Timing Diagram**

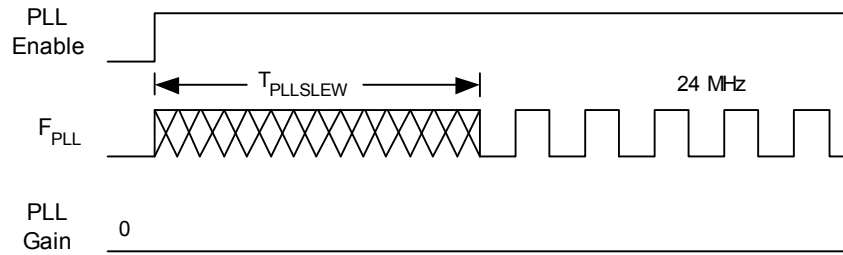

**Figure 7. PLL Lock for Low Gain Setting Timing Diagram**

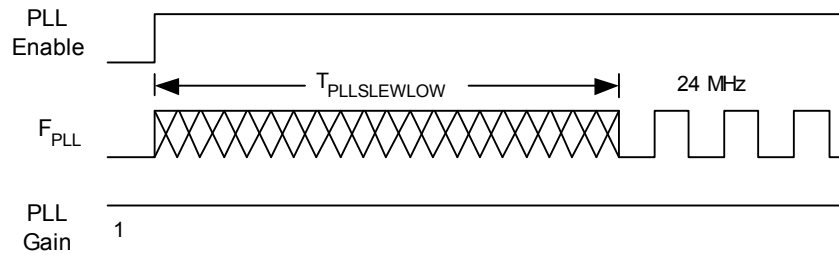

**Figure 8. External Crystal Oscillator Startup Timing Diagram**

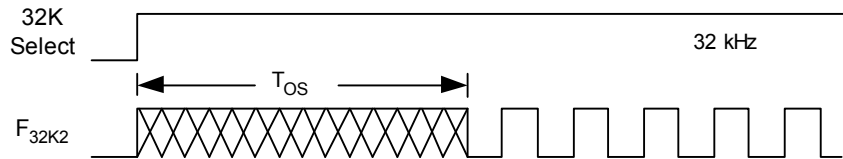

**Figure 9. 24 MHz Period Jitter (IMO) Timing Diagram**

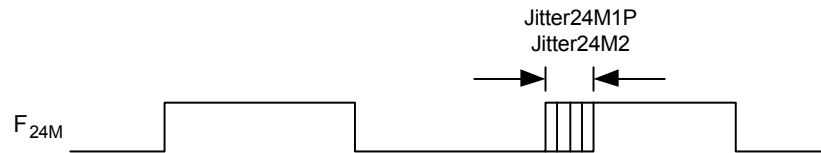

**Figure 10. 32 kHz Period Jitter (ECO) Timing Diagram**



AC General Purpose I/O Specifications

The following tables list guaranteed maximum and minimum specifications for the voltage and temperature ranges: 4.75V to 5.25V and  $-40^{\circ}\text{C} \leq T_A \leq 125^{\circ}\text{C}$ . Typical parameters apply to 5V at 25°C and are for design guidance only.

Table 21. AC GPIO Specifications

Symbol	Description	Min	Typ	Max	Units	Notes
F <sub>GPIO</sub>	GPIO Operating Frequency	0	–	12.48 <sup>[12]</sup>	MHz	Normal Strong Mode
T <sub>RiseF</sub>	Rise Time, Normal Strong Mode, Clload = 50 pF	2	–	22	ns	10% - 90%
T <sub>FallF</sub>	Fall Time, Normal Strong Mode, Clload = 50 pF	2	–	22	ns	10% - 90%
T <sub>RiseS</sub>	Rise Time, Slow Strong Mode, Clload = 50 pF	9	27	–	ns	10% - 90%
T <sub>FallS</sub>	Fall Time, Slow Strong Mode, Clload = 50 pF	9	22	–	ns	10% - 90%

Figure 11. GPIO Timing Diagram

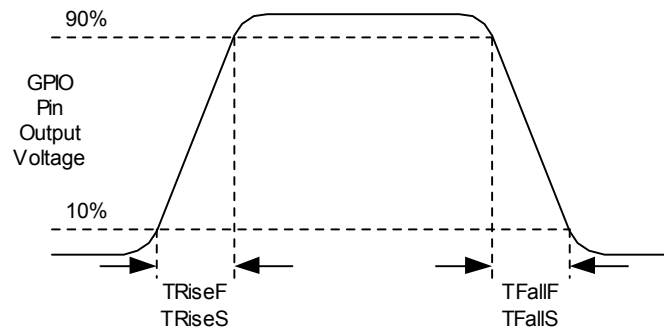

AC Operational Amplifier Specifications

The following tables list guaranteed maximum and minimum specifications for the voltage and temperature ranges: 4.75V to 5.25V and  $-40^{\circ}\text{C} \leq T_A \leq 125^{\circ}\text{C}$ . Typical parameters apply to 5V at 25°C and are for design guidance only.

**Note** Settling times, slew rates, and gain bandwidth are based on the Analog Continuous Time PSoC block.

Table 22. AC Operational Amplifier Specifications

Symbol	Description	Min	Typ	Max	Units
SR <sub>ROA</sub>	Rising Slew Rate (20% to 80%) (10 pF load, Unity Gain)				
	Power = Low, Opamp Bias = Low	0.15	–	–	V/μs
	Power = Low, Opamp Bias = High	0.15	–	–	V/μs
	Power = Medium, Opamp Bias = Low	0.15	–	–	V/μs
	Power = Medium, Opamp Bias = High	1.7	–	–	V/μs
	Power = High, Opamp Bias = Low	1.7	–	–	V/μs
	Power = High, Opamp Bias = High	6.5	–	–	V/μs
SR <sub>FOA</sub>	Falling Slew Rate (80% to 20%) (10 pF load, Unity Gain)				
	Power = Low, Opamp Bias = Low	0.01	–	–	V/μs
	Power = Low, Opamp Bias = High	0.01	–	–	V/μs
	Power = Medium, Opamp Bias = Low	0.01	–	–	V/μs
	Power = Medium, Opamp Bias = High	0.5	–	–	V/μs
	Power = High, Opamp Bias = Low	0.5	–	–	V/μs
	Power = High, Opamp Bias = High	4.0	–	–	V/μs
BW <sub>OA</sub>	Gain Bandwidth Product				
	Power = Low, Opamp Bias = Low	0.75	–	–	MHz
	Power = Low, Opamp Bias = High	0.75	–	–	MHz
	Power = Medium, Opamp Bias = Low	0.75	–	–	MHz
	Power = Medium, Opamp Bias = High	3.1	–	–	MHz
	Power = High, Opamp Bias = Low	3.1	–	–	MHz
	Power = High, Opamp Bias = High	5.4	–	–	MHz

AC Low Power Comparator Specifications

The following tables list guaranteed maximum and minimum specifications for the voltage and temperature ranges: 4.75V to 5.25V and  $-40^{\circ}\text{C} \leq T_A \leq 125^{\circ}\text{C}$ . Typical parameters apply to 5V at 25°C and are for design guidance only.

Table 23. AC Low Power Comparator Specifications

Symbol	Description	Min	Typ	Max	Units	Notes
T <sub>RLPC</sub>	LPC response time	–	–	50	μs	≥ 50 mV overdrive comparator reference set within V <sub>REFLPC</sub> .

When bypassed by a capacitor on P2[4], the noise of the analog ground signal distributed to each block is reduced by a factor of up to 5 (14 dB). This is at frequencies above the corner frequency defined by the on-chip 8.1k resistance and the external capacitor.

Figure 12. Typical AGND Noise with P2[4] Bypass

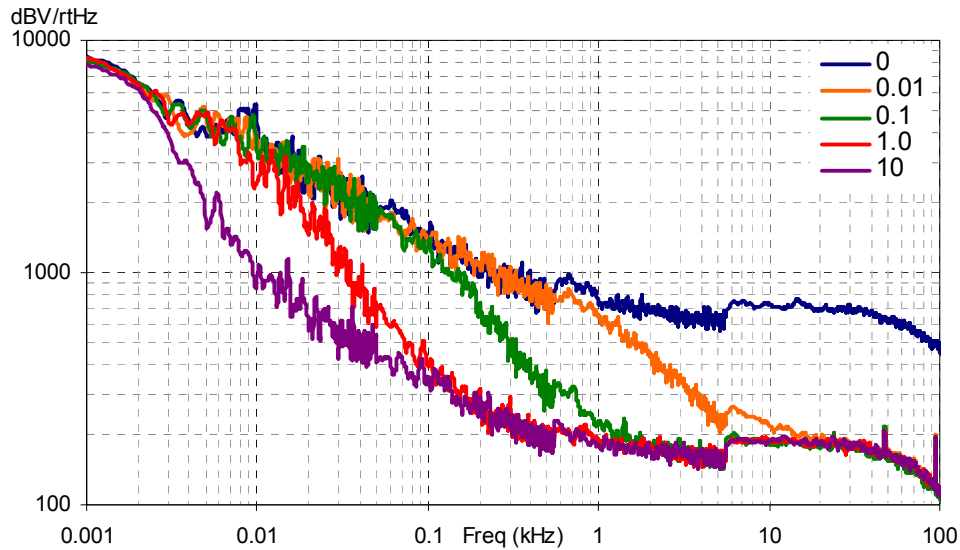

At low frequencies, the opamp noise is proportional to 1/f, power independent, and determined by device geometry. At high frequencies, increased power level reduces the noise spectrum level.

Figure 13. Typical Opamp Noise

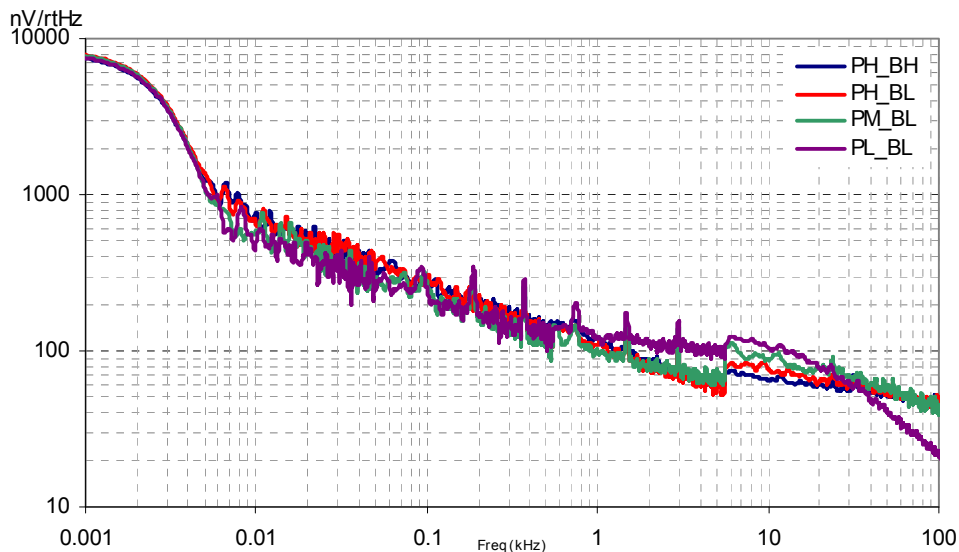

**AC Digital Block Specifications**

The following tables list guaranteed maximum and minimum specifications for the voltage and temperature ranges: 4.75V to 5.25V and  $-40^{\circ}\text{C} \leq T_A \leq 125^{\circ}\text{C}$ . Typical parameters apply to 5V at 25°C and are for design guidance only.

**Table 24. AC Digital Block Specifications**

Function	Description	Min	Typ	Max	Units	Notes
All Functions	Maximum Block Clocking Frequency	–	–	24.96 <sup>[12]</sup>	MHz	
Timer	Capture Pulse Width	50 <sup>[14]</sup>	–	–	ns	
	Maximum Frequency, No Capture	–	–	24.96 <sup>[12]</sup>	MHz	
	Maximum Frequency, With Capture	–	–	24.96 <sup>[12]</sup>	MHz	
Counter	Enable Pulse Width	50 <sup>[14]</sup>	–	–	ns	
	Maximum Frequency, No Enable Input	–	–	24.96 <sup>[12]</sup>	MHz	
	Maximum Frequency, Enable Input	–	–	24.96 <sup>[12]</sup>	MHz	
Dead Band	Kill Pulse Width:					
	Asynchronous Restart Mode	20	–	–	ns	
	Synchronous Restart Mode	50 <sup>[14]</sup>	–	–	ns	
	Disable Mode	50 <sup>[14]</sup>	–	–	ns	
	Maximum Frequency	–	–	24.96 <sup>[12]</sup>	MHz	
CRCPRS (PRS Mode)	Maximum Input Clock Frequency	–	–	24.96 <sup>[12]</sup>	MHz	
CRCPRS (CRC Mode)	Maximum Input Clock Frequency	–	–	24.96 <sup>[12]</sup>	MHz	
SPIM	Maximum Input Clock Frequency	–	–	4.16 <sup>[12]</sup>	MHz	Maximum data rate is 2.08 Mbps due to 2 x over clocking.
SPIS	Maximum Input Clock Frequency	–	–	2.08 <sup>[12]</sup>	MHz	
	Width of SS_ Negated Between Transmissions	50 <sup>[14]</sup>	–	–	ns	
Transmitter	Maximum Input Clock Frequency	–	–	8.32 <sup>[12]</sup>	MHz	Maximum baud rate is 1.04 Mbaud due to 8 x over clocking.
Receiver	Maximum Input Clock Frequency	–	–	24.96 <sup>[12]</sup>	MHz	Maximum baud rate is 3.12 Mbaud due to 8 x over clocking.

**Note**

14. 50 ns minimum input pulse width is based on the input synchronizers running at 24 MHz (42 ns nominal period).

### AC Analog Output Buffer Specifications

The following tables list guaranteed maximum and minimum specifications for the voltage and temperature ranges: 4.75V to 5.25V and  $-40^{\circ}\text{C} \leq T_A \leq 125^{\circ}\text{C}$ . Typical parameters apply to 5V at  $25^{\circ}\text{C}$  and are for design guidance only.

**Table 25. AC Analog Output Buffer Specifications**

Symbol	Description	Min	Typ	Max	Units
T <sub>ROB</sub>	Rising Settling Time to 0.1%, 1V Step, 100 pF Load Power = Low Power = High	–	–	3	μs
		–	–	3	μs
T <sub>SOB</sub>	Falling Settling Time to 0.1%, 1V Step, 100 pF Load Power = Low Power = High	–	–	3	μs
		–	–	3	μs
SR <sub>ROB</sub>	Rising Slew Rate (20% to 80%), 1V Step, 100 pF Load Power = Low Power = High	0.6	–	–	V/μs
		0.6	–	–	V/μs
SR <sub>FOB</sub>	Falling Slew Rate (80% to 20%), 1V Step, 100 pF Load Power = Low Power = High	0.6	–	–	V/μs
		0.6	–	–	V/μs
BW <sub>OB</sub>	Small Signal Bandwidth, 20mV <sub>pp</sub> , 3dB BW, 100 pF Load Power = Low Power = High	0.8	–	–	MHz
		0.8	–	–	MHz
BW <sub>OB</sub>	Large Signal Bandwidth, 1V <sub>pp</sub> , 3dB BW, 100 pF Load Power = Low Power = High	300	–	–	kHz
		300	–	–	kHz

### AC External Clock Specifications

The following tables list guaranteed maximum and minimum specifications for the voltage and temperature ranges: 4.75V to 5.25V and  $-40^{\circ}\text{C} \leq T_A \leq 125^{\circ}\text{C}$ . Typical parameters apply to 5V at  $25^{\circ}\text{C}$  and are for design guidance only.

**Table 26. AC External Clock Specifications**

Symbol	Description	Min	Typ	Max	Units	Notes
F <sub>OSCEXT</sub>	Frequency	0.093	–	24.24	MHz	
–	High Period	20.6	–	–	ns	
–	Low Period	20.6	–	–	ns	
–	Power Up IMO to Switch	150	–	–	μs	

### AC Programming Specifications

The following table lists guaranteed maximum and minimum specifications for the voltage and temperature ranges: 4.75V to 5.25V and  $-40^{\circ}\text{C} \leq T_A \leq 125^{\circ}\text{C}$ . Typical parameters apply to 5V at  $25^{\circ}\text{C}$  and are for design guidance only.

**Table 27. AC Programming Specifications**

Symbol	Description	Min	Typ	Max	Units	Notes
T <sub>RSCLK</sub>	Rise Time of SCLK	1	–	20	ns	
T <sub>FSCLK</sub>	Fall Time of SCLK	1	–	20	ns	
T <sub>SSCLK</sub>	Data Set up Time to Falling Edge of SCLK	40	–	–	ns	
T <sub>HSCLK</sub>	Data Hold Time from Falling Edge of SCLK	40	–	–	ns	
F <sub>SCLK</sub>	Frequency of SCLK	0	–	8	MHz	
T <sub>ERASEB</sub>	Flash Erase Time (Block)	–	20	80 <sup>[9]</sup>	ms	
T <sub>WRITE</sub>	Flash Block Write Time	–	80	320 <sup>[9]</sup>	ms	
T <sub>DSCLK</sub>	Data Out Delay from Falling Edge of SCLK	–	–	50	ns	
T <sub>PRGH</sub>	Total Flash Block Program Time (T <sub>ERASEB</sub> + T <sub>WRITE</sub> ), Hot	–	–	200 <sup>[9]</sup>	ms	T <sub>J</sub> ≥ 0°C
T <sub>PRGC</sub>	Total Flash Block Program Time (T <sub>ERASEB</sub> + T <sub>WRITE</sub> ), Cold	–	–	400 <sup>[9]</sup>	ms	T <sub>J</sub> < 0°C

**AC I<sup>2</sup>C Specifications**

The following tables list guaranteed maximum and minimum specifications for the voltage and temperature ranges: 4.75V to 5.25V and  $-40^{\circ}\text{C} \leq T_A \leq 125^{\circ}\text{C}$ . Typical parameters apply to 5V at 25°C and are for design guidance only.

**Table 28. AC Characteristics of the I<sup>2</sup>C SDA and SCL Pins**

Symbol	Description	Standard Mode		Fast Mode		Units
		Min	Max	Min	Max	
F <sub>SCL I2C</sub>	SCL Clock Frequency	0	100 <sup>[15]</sup>	0	400 <sup>[15]</sup>	kHz
T <sub>HDSTAI2C</sub>	Hold Time (repeated) START Condition. After this period, the first clock pulse is generated.	4.0	–	0.6	–	μs
T <sub>LOWI2C</sub>	LOW Period of the SCL Clock	4.7	–	1.3	–	μs
T <sub>HIGHI2C</sub>	HIGH Period of the SCL Clock	4.0	–	0.6	–	μs
T <sub>SUSTA I2C</sub>	Setup Time for a Repeated START Condition	4.7	–	0.6	–	μs
T <sub>HDDATI2C</sub>	Data Hold Time	0	–	0	–	μs
T <sub>SUDATI2C</sub>	Data Setup Time	250	–	100 <sup>[16]</sup>	–	ns
T <sub>SUSTOI2C</sub>	Setup Time for STOP Condition	4.0	–	0.6	–	μs
T <sub>BUFI2C</sub>	Bus Free Time Between a STOP and START Condition	4.7	–	1.3	–	μs
T <sub>SPI2C</sub>	Pulse Width of spikes are suppressed by the input filter.	–	–	0	50	ns

**Figure 14. Definition for Timing for Fast/Standard Mode on the I<sup>2</sup>C Bus**

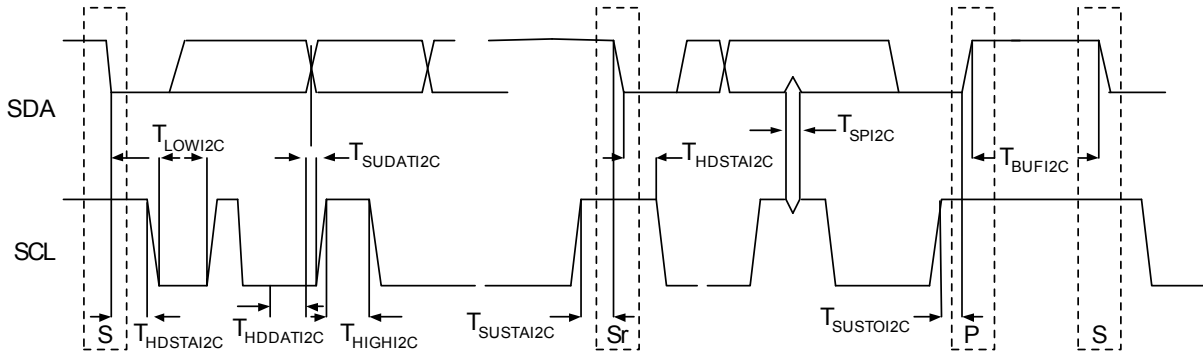

**Notes**

15. F<sub>SCL I2C</sub> is derived from SysClk of the PSoC. This specification assumes that SysClk is operating at 24 MHz, nominal. If SysClk is at a lower frequency, then the F<sub>SCL I2C</sub> specification adjusts accordingly.
16. A Fast-Mode I<sup>2</sup>C-bus device can be used in a Standard-Mode I<sup>2</sup>C-bus system, but the requirement T<sub>SUDATI2C</sub> ≥ 250 ns must then be met. This is automatically the case if the device does not stretch the LOW period of the SCL signal. If such device does stretch the LOW period of the SCL signal, it must output the next data bit to the SDA line t<sub>max</sub> + T<sub>SUDATI2C</sub> = 1000 + 250 = 1250 ns (according to the Standard-Mode I<sup>2</sup>C-bus specification) before the SCL line is released.

### Packaging Information

This section illustrates the packaging specifications for the automotive CY8C24x23A PSoC device, along with the thermal impedances for each package and the typical package capacitance on crystal pins.

**Important Note** Emulation tools may require a larger area on the target PCB than the chip's footprint. For a detailed description of the emulation tools' dimensions, refer to the emulator pod drawings at <http://www.cypress.com>.

Figure 15. 20-Pin (210-Mil) SSOP

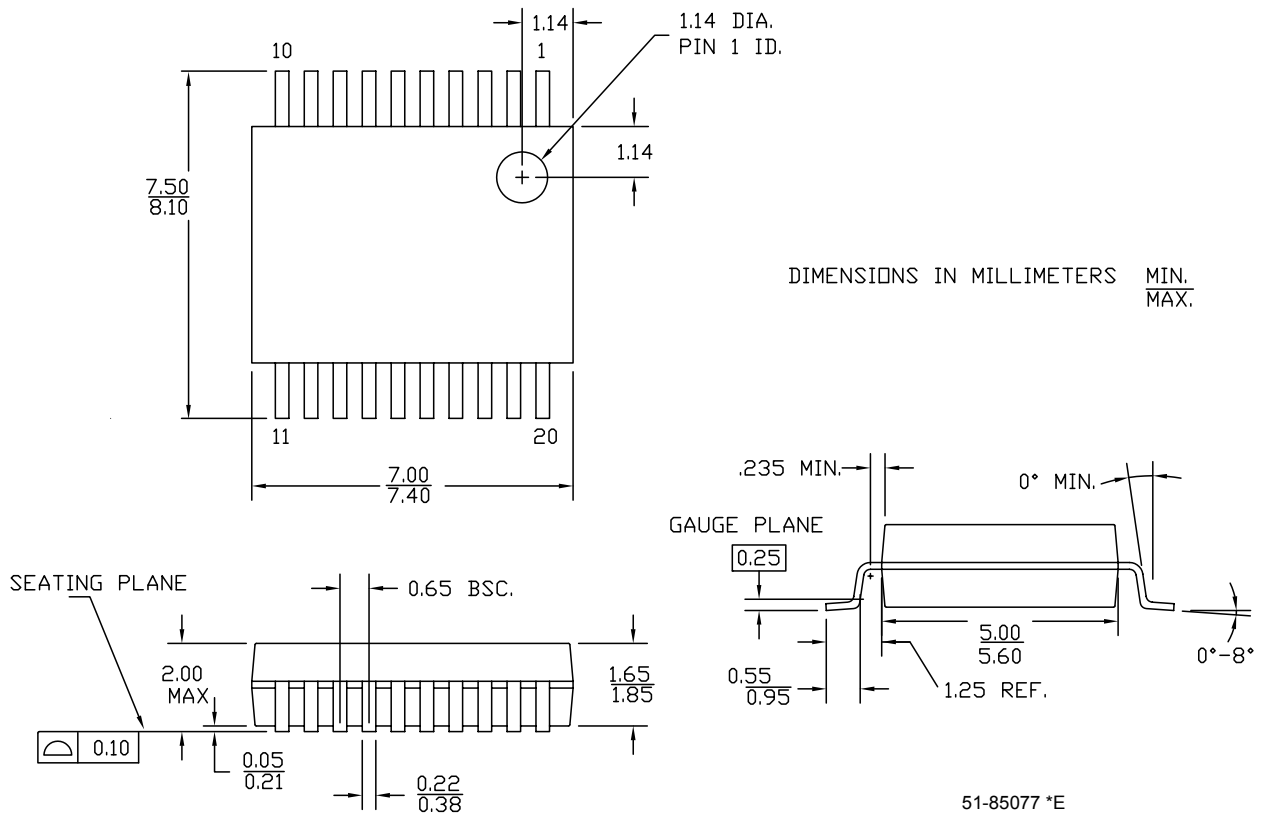
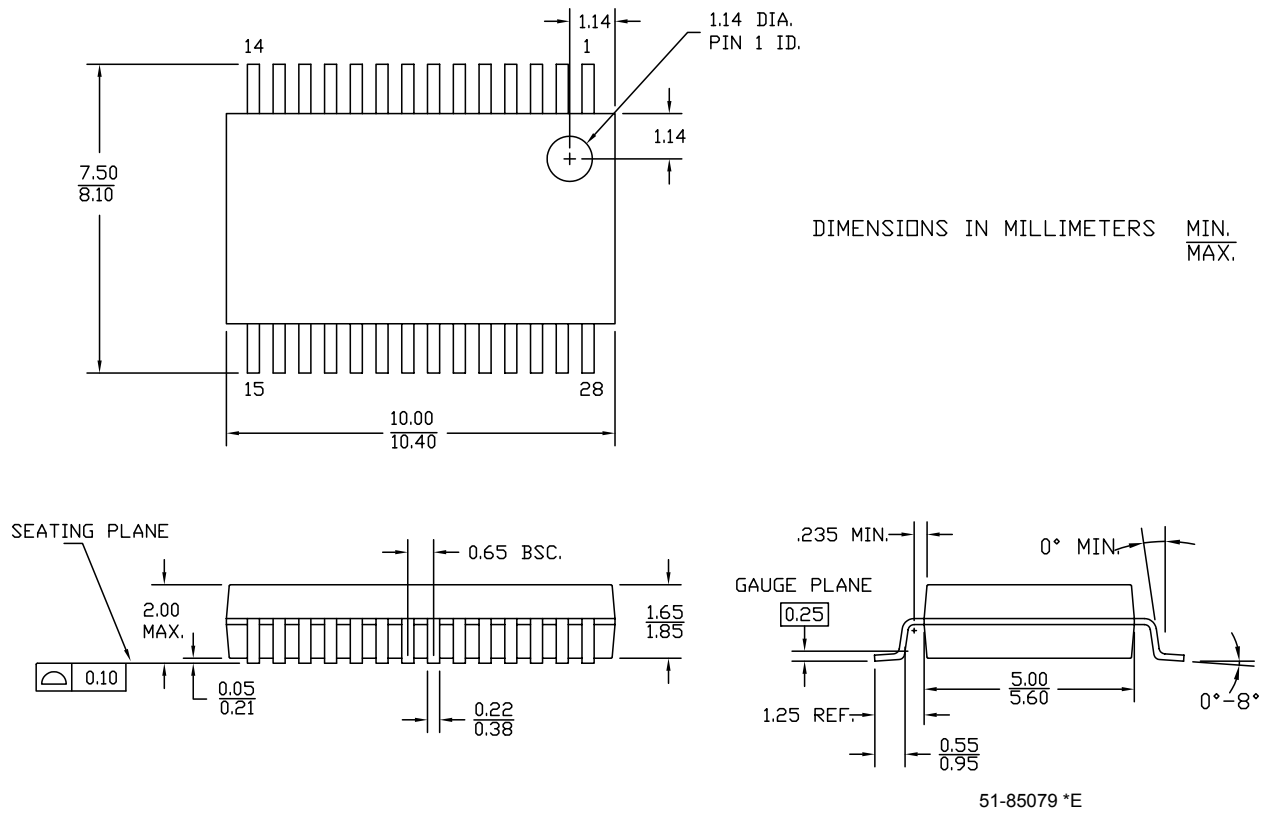

Figure 16. 28-Pin (210-Mil) SSOP



**Thermal Impedances**

Package	Typical $\theta_{JA}$ <sup>[17]</sup>
20 SSOP	117 °C/W
28 SSOP	101 °C/W

**Capacitance on Crystal Pins**

Package	Package Capacitance
20 SSOP	2.6 pF
28 SSOP	2.8 pF

**Solder Reflow Specifications**

The following table shows the solder reflow temperature limits that must not be exceeded.

Package	Maximum Time above $T_C - 5\text{ °C}$	Maximum Peak Temperature
20 SSOP	30 seconds	260°C
28 SSOP	30 seconds	260°C

**Note**  
17.  $T_J = T_A + \text{POWER} \times \theta_{JA}$

## Development Tool Selection

This section presents the development tools available for the CY8C24x23A family.

### Software

#### *PSoC Designer*

At the core of the PSoC development software suite is PSoC Designer. Utilized by thousands of PSoC developers, this robust software has been facilitating PSoC designs for years. PSoC Designer is available free of charge at <http://www.cypress.com>. PSoC Designer comes with a free C compiler.

#### *PSoC Programmer*

Flexible enough to be used on the bench in development, yet suitable for factory programming, PSoC Programmer works either as a standalone programming application or it can operate directly from PSoC Designer. PSoC Programmer software is compatible with both PSoC ICE-Cube In-Circuit Emulator and PSoC MiniProg. PSoC programmer is available free of charge at <http://www.cypress.com>.

### Development Kits

All development kits can be purchased from the Cypress Online Store. The online store also has the most up to date information on kit contents, descriptions, and availability.

#### *CY3215-DK Basic Development Kit*

The CY3215-DK is for prototyping and development with PSoC Designer. This kit supports in-circuit emulation and the software interface allows users to run, halt, and single step the processor and view the contents of specific memory locations. Advanced emulation features are also supported through PSoC Designer. The kit includes:

- ICE-Cube Unit
- 28-Pin PDIP Emulation Pod for CY8C29466-24PXI
- 28-Pin CY8C29466-24PXI PDIP PSoC Device Samples (two)
- PSoC Designer Software CD
- ISSP Cable
- MiniEval Socket Programming and Evaluation board
- Backward Compatibility Cable (for connecting to legacy Pods)
- Universal 110/220 Power Supply (12V)
- European Plug Adapter
- USB 2.0 Cable
- Getting Started Guide
- Development Kit Registration form

### Evaluation Tools

All evaluation tools can be purchased from the Cypress Online Store. The online store also has the most up to date information on kit contents, descriptions, and availability.

#### *CY3210-PSoCEval1*

The CY3210-PSoCEval1 kit features an evaluation board and the MiniProg1 programming unit. The evaluation board includes an LCD module, potentiometer, LEDs, an RS-232 port, and plenty of breadboarding space to meet all of your evaluation needs. The kit includes:

- Evaluation Board with LCD Module
- MiniProg Programming Unit
- 28-Pin CY8C29466-24PXI PDIP PSoC Device Sample (2)
- PSoC Designer Software CD
- Getting Started Guide
- USB 2.0 Cable

#### *CY3210-24X23 Evaluation Pod (EvalPod)*

PSoC EvalPods are pods that connect to the ICE In-Circuit Emulator (CY3215-DK kit) to allow debugging capability. They can also function as a standalone device without debugging capability. The EvalPod has a 28-pin DIP footprint on the bottom for easy connection to development kits or other hardware. The top of the EvalPod has prototyping headers for easy connection to the device's pins. CY3210-24X23 provides evaluation of the CY8C24x23A PSoC device family.

**Device Programmers**

All device programmers can be purchased from the Cypress Online Store.

*CY3210-MiniProg1*

The CY3210-MiniProg1 kit allows a user to program PSoC devices via the MiniProg1 programming unit. The MiniProg is a small, compact prototyping programmer that connects to the PC via a provided USB 2.0 cable. The kit includes:

- MiniProg Programming Unit
- MiniEval Socket Programming and Evaluation Board
- 28-Pin CY8C29466-24PXI PDIP PSoC Device Sample
- PSoC Designer Software CD
- Getting Started Guide
- USB 2.0 Cable

**Accessories (Emulation and Programming)**

**Table 29. Emulation and Programming Accessories**

Part Number	Pin Package	Pod Kit <sup>[18]</sup>	Foot Kit <sup>[19]</sup>	Adapter <sup>[20]</sup>
CY8C24223A-12PVXE	20 SSOP	CY3250-24X23A	CY3250-20SSOP-FK	Adapters can be found at <a href="http://www.emulation.com">http://www.emulation.com</a> .
CY8C24423A-12PVXE	28 SSOP	CY3250-24X23A	CY3250-28SSOP-FK	

*CY3207ISSP In-System Serial Programmer (ISSP)*

The CY3207ISSP is a production programmer. It includes protection circuitry and an industrial case that is more robust than the MiniProg in a production-programming environment.

**Note:** CY3207ISSP needs special software and is not compatible with PSoC Programmer. This software is free and can be downloaded from <http://www.cypress.com>. The kit includes:

- CY3207 Programmer Unit
- PSoC ISSP Software CD
- 110 ~ 240V Power Supply, Euro-Plug Adapter
- USB 2.0 Cable

**Notes**

18. Pod kit contains an emulation pod, a flex-cable (connects the pod to the ICE), two feet, and device samples.

19. Foot kit includes surface mount feet that can be soldered to the target PCB.

20. Programming adapter converts non-DIP package to DIP footprint. Specific details and ordering information for each of the adapters can be found at <http://www.emulation.com>.

## Ordering Information

The following table lists the automotive CY8C24x23A PSoC device group's key package features and ordering codes.

Package	Ordering Code	Flash (Bytes)	RAM (Bytes)	Switch Mode Pump	Temperature Range	Digital Blocks	Analog Blocks	Digital I/O Pins	Analog Inputs	Analog Outputs	XRES Pin
20 Pin (210 Mil) SSOP	CY8C24223A-12PVXE	4K	256	No	-40°C to +125°C	4	6	16	8	2	Yes
20 Pin (210 Mil) SSOP (Tape and Reel)	CY8C24223A-12PVXET	4K	256	No	-40°C to +125°C	4	6	16	8	2	Yes
28 Pin (210 Mil) SSOP	CY8C24423A-12PVXE	4K	256	No	-40°C to +125°C	4	6	24	12 <sup>[1]</sup>	2	Yes
28 Pin (210 Mil) SSOP (Tape and Reel)	CY8C24423A-12PVXET	4K	256	No	-40°C to +125°C	4	6	24	12 <sup>[1]</sup>	2	Yes

## Ordering Code Definitions

CY 8 C 24 xxx-12xx

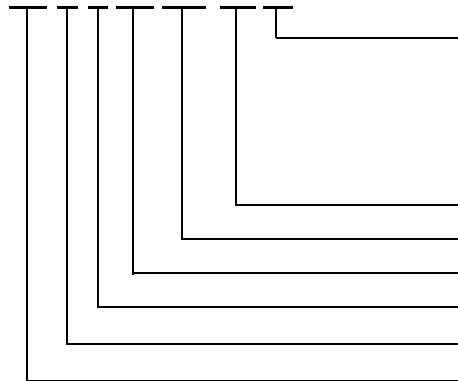

**Package Type:**

- PX = PDIP Pb-free
- SX = SOIC Pb-free
- PVX = SSOP Pb-free
- LFX/LKX = QFN Pb-free
- AX = TQFP Pb-free

**Thermal Rating:**

- A = Automotive -40°C to +85°C
- C = Commercial
- I = Industrial
- E = Automotive Extended -40°C to +125°C

CPU Speed: 12 MHz

Part Number

Family Code

Technology Code: C = CMOS

Marketing Code: 8 = PSoC

Company ID: CY = Cypress

**Document History Page**

Document Title: CY8C24223A, CY8C24423A Automotive - Extended Temperature PSoC® Programmable System-on-Chip Document Number: 38-12029				
Rev.	ECN	Orig. of Change	Submission Date	Description of Change
**	238268	SFV	See ECN	First release of CY8C24x23A Automotive Preliminary Data Sheet.
*A	271471	HMT	See ECN	Update per SFV memo. Input MWR changes, including removing SMP. Change to Final.
*B	286089	HMT	See ECN	Update characterization data. Fine tune pinouts. Add Reflow Peak Temp. table.
*C	512475	HMT	See ECN	Add Low Power Comparator (LPC) AC/DC electrical spec. tables. Add ISSP note to pinout tables. Update typical and recommended Storage Temperature per extended temp. specs. Update CY branding and QFN convention. Update copyright and trademarks.
*D	2101387	AESA	See ECN	Post to <a href="http://www.cypress.com">www.cypress.com</a>
*E	2619935	OGNE/AESA	12/11/2008	Changed title to "CY8C24223A, CY8C24423A PSoC® Programmable System-on-Chip™" Added note on digital signaling in <a href="#">DC Analog Reference Specifications</a> on page 19. Added Die Sales information note to <a href="#">Ordering Information</a> on page 32. Updated data sheet template.
*F	2659314	PRKA/PYRS	02/13/09	Changed title to "Automotive - Extended Temperature CY8C24223A, CY8C24423A PSoC® Programmable System-on-Chip™" Updated Development Tools and Designing with PSoC Designer sections on pages 5 and 6.
*G	2719510	BTK	06/16/09	Changed title. Updated Features section. Updated text of PSoC Functional Overview section. Updated Getting Started section. Made corrections and minor text edits to Pinouts section. Changed the name of the Register Reference section to "Registers". Improved formatting of the register tables. Added clarifying comments to some electrical specifications. Changed T <sub>RAMP</sub> specification per MASJ input. Changed number of analog inputs for 28-pin package to 12 from 10. Fixed all AC specifications to conform to a ±4% IMO accuracy. Made other miscellaneous minor text edits. Deleted some non-applicable or redundant information. Added a footnote to clarify that 8 of the 12 analog inputs are regular and the other 4 are direct SC block connections. Added Development Tool Selection section.
*H	2822792	BTK/AESA	12/07/2009	Added T <sub>PRGH</sub> , T <sub>PRGC</sub> , I <sub>OL</sub> , I <sub>OH</sub> , F <sub>32KU</sub> , DC <sub>ILO</sub> , and T <sub>POWERUP</sub> electrical specifications. Updated the text of footnote 10. Added maximum values and updated typical values for T <sub>ERASEB</sub> and T <sub>WRITE</sub> electrical specifications. Replaced T <sub>RAMP</sub> electrical specification with SR <sub>POWERUP</sub> electrical specification. Added " <a href="#">Contents</a> " on page 2. This revision fixes CDT 63984.
*I	2888007	NJF	03/30/2010	Updated Cypress website links. Updated PSoC Designer Software Subsystems. Added T <sub>BAKETEMP</sub> and T <sub>BAKETIME</sub> parameters in Absolute Maximum Ratings. Updated links in <a href="#">Sales, Solutions, and Legal Information</a> . Removed Third Party Tools and Build a PSoC Emulator into your Board.
*J	3184892	PRKA/VIVG	03/01/2011	No change. Sunset review spec.
*K	3726340	08/28/2012	tess_ukr/ LURE	Updated the following sections: Getting Started, Development Tools, and Designing with PSoC Designer as all the System level designs have been de-emphasized. Changed the PWM description string from "8- to 32-bit" to "8- and 16-bit". Updated package diagrams. Updated solder reflow specifications.
*L	4304787	03/11/2014	JICG	Updated in new template.  Completing Sunset Review.

## Sales, Solutions, and Legal Information

### Worldwide Sales and Design Support

Cypress maintains a worldwide network of offices, solution centers, manufacturer's representatives, and distributors. To find the office closest to you, visit us at [Cypress Locations](#).

#### Products

Automotive	<a href="http://cypress.com/go/automotive">cypress.com/go/automotive</a>
Clocks & Buffers	<a href="http://cypress.com/go/clocks">cypress.com/go/clocks</a>
Interface	<a href="http://cypress.com/go/interface">cypress.com/go/interface</a>
Lighting & Power Control	<a href="http://cypress.com/go/powerpsoc">cypress.com/go/powerpsoc</a> <a href="http://cypress.com/go/plc">cypress.com/go/plc</a>
Memory	<a href="http://cypress.com/go/memory">cypress.com/go/memory</a>
PSoC	<a href="http://cypress.com/go/psoc">cypress.com/go/psoc</a>
Touch Sensing	<a href="http://cypress.com/go/touch">cypress.com/go/touch</a>
USB Controllers	<a href="http://cypress.com/go/USB">cypress.com/go/USB</a>
Wireless/RF	<a href="http://cypress.com/go/wireless">cypress.com/go/wireless</a>

#### PSoC<sup>®</sup> Solutions

[psoc.cypress.com/solutions](http://psoc.cypress.com/solutions)  
PSoC 1 | PSoC 3 | PSoC 4 | PSoC 5LP

#### Cypress Developer Community

[Community](#) | [Forums](#) | [Blogs](#) | [Video](#) | [Training](#)

#### Technical Support

[cypress.com/go/support](http://cypress.com/go/support)

---

© Cypress Semiconductor Corporation, 2004-2014. The information contained herein is subject to change without notice. Cypress Semiconductor Corporation assumes no responsibility for the use of any circuitry other than circuitry embodied in a Cypress product. Nor does it convey or imply any license under patent or other rights. Cypress products are not warranted nor intended to be used for medical, life support, life saving, critical control or safety applications, unless pursuant to an express written agreement with Cypress. Furthermore, Cypress does not authorize its products for use as critical components in life-support systems where a malfunction or failure may reasonably be expected to result in significant injury to the user. The inclusion of Cypress products in life-support systems application implies that the manufacturer assumes all risk of such use and in doing so indemnifies Cypress against all charges.

Any Source Code (software and/or firmware) is owned by Cypress Semiconductor Corporation (Cypress) and is protected by and subject to worldwide patent protection (United States and foreign), United States copyright laws and international treaty provisions. Cypress hereby grants to licensee a personal, non-exclusive, non-transferable license to copy, use, modify, create derivative works of, and compile the Cypress Source Code and derivative works for the sole purpose of creating custom software and/or firmware in support of licensee product to be used only in conjunction with a Cypress integrated circuit as specified in the applicable agreement. Any reproduction, modification, translation, compilation, or representation of this Source Code except as specified above is prohibited without the express written permission of Cypress.

Disclaimer: CYPRESS MAKES NO WARRANTY OF ANY KIND, EXPRESS OR IMPLIED, WITH REGARD TO THIS MATERIAL, INCLUDING, BUT NOT LIMITED TO, THE IMPLIED WARRANTIES OF MERCHANTABILITY AND FITNESS FOR A PARTICULAR PURPOSE. Cypress reserves the right to make changes without further notice to the materials described herein. Cypress does not assume any liability arising out of the application or use of any product or circuit described herein. Cypress does not authorize its products for use as critical components in life-support systems where a malfunction or failure may reasonably be expected to result in significant injury to the user. The inclusion of Cypress' product in a life-support systems application implies that the manufacturer assumes all risk of such use and in doing so indemnifies Cypress against all charges.

Use may be limited by and subject to the applicable Cypress software license agreement.

## Looking for pricing, stock, or lifecycle information?

Click below to explore more details on WIN SOURCE:

- ⊖ [View CY8C24423A-12PVXET on WIN SOURCE](#)
- ⊖ [Cypress Semiconductor Corp Information](#)

## Optimize Your Supply Chain with WIN SOURCE Solutions

- ✓ Global Sourcing Solution
- ✓ Obsolete Management
- ✓ Cost Control Management
- ✓ Shortage Management
- ✓ Alternative Solution
- ✓ Excess Inventory Management