



**THE DATASHEET OF
SN74ALS29821DW**



SN54ALS29821, SN74ALS29821 10-BIT BUS-INTERFACE FLIP-FLOPS WITH 3-STATE OUTPUTS

SDAS145B – JANUARY 1986 – REVISED JANUARY 1995

- Functionally Equivalent to AMD's AM29821
- Provide Extra Data Width Necessary for Wider Address/Data Paths or Buses With Parity
- Outputs Have Undershoot-Protection Circuitry
- Power-Up High-Impedance State
- Buffered Control Inputs Reduce dc Loading Effects
- Package Options Include Plastic Small-Outline (DW) Packages and Standard Plastic (NT) and Ceramic (JT) 300-mil DIPs

SN54ALS29821 . . . JT PACKAGE
SN74ALS29821 . . . DW OR NT PACKAGE
(TOP VIEW)

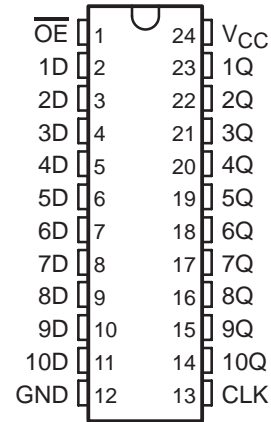

description

These 10-bit edge-triggered D-type flip-flops feature 3-state outputs designed specifically for driving highly capacitive or relatively low-impedance loads. These devices are particularly suitable for implementing wider buffer registers, I/O ports, bidirectional bus drivers with parity, and working registers.

On the positive transition of the clock (CLK) input, the Q outputs are true to the data (D) input.

A buffered output-enable (\overline{OE}) input can place the ten outputs in either a normal logic state (high or low logic levels) or a high-impedance state. The outputs also are in the high-impedance state during power-up and power-down conditions. The outputs remain in the high-impedance state while the device is powered down. In the high-impedance state, the outputs neither load nor drive the bus lines significantly. The high-impedance state and increased drive provide the capability to drive bus lines without interface or pullup components.

\overline{OE} does not affect the internal operation of the flip-flops. Old data can be retained or new data can be entered while the outputs are in the high-impedance state.

The SN54ALS29821 is characterized for operation over the full military temperature range of -55°C to 125°C . The SN74ALS29821 is characterized for operation from 0°C to 70°C .

FUNCTION TABLE
(each flip-flop)

INPUTS			OUTPUT
\overline{OE}	CLK	D	Q
L	\uparrow	H	H
L	\uparrow	L	L
L	L	X	Q_0
H	X	X	Z

SN54ALS29821, SN74ALS29821 10-BIT BUS-INTERFACE FLIP-FLOPS WITH 3-STATE OUTPUTS

SDAS145B – JANUARY 1986 – REVISED JANUARY 1995

logic symbol†

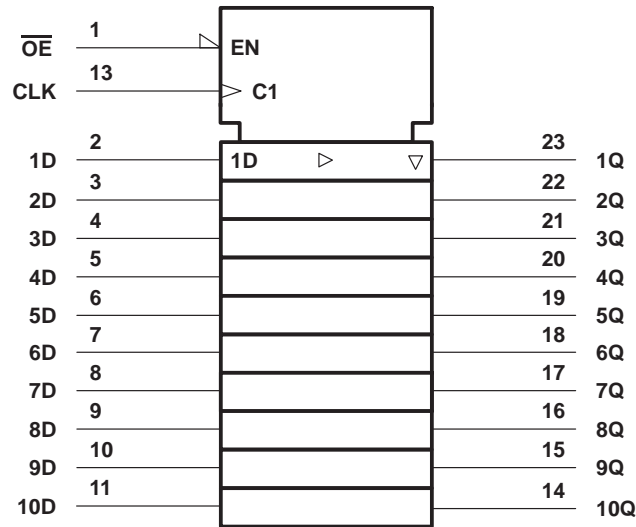

† This symbol is in accordance with ANSI/IEEE Std 91-1984 and IEC Publication 617-12.

logic diagram (positive logic)

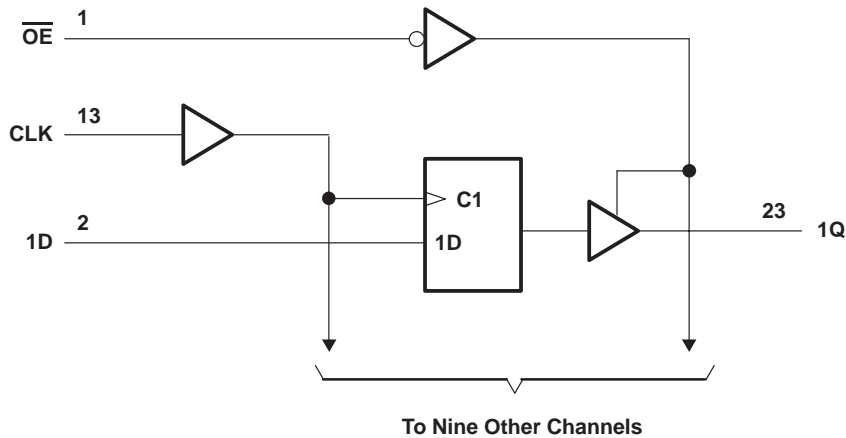

absolute maximum ratings over operating free-air temperature range (unless otherwise noted)‡

Supply voltage, V_{CC}	7 V
Input voltage, V_I	5.5 V
Voltage applied to a disabled 3-state output	5.5 V
Operating free-air temperature range, T_A : SN54ALS29821	-55°C to 125°C
SN74ALS29821	0°C to 70°C
Storage temperature range	-65°C to 150°C

‡ Stresses beyond those listed under "absolute maximum ratings" may cause permanent damage to the device. These are stress ratings only, and functional operation of the device at these or any other conditions beyond those indicated under "recommended operating conditions" is not implied. Exposure to absolute-maximum-rated conditions for extended periods may affect device reliability.

SN54ALS29821, SN74ALS29821 10-BIT BUS-INTERFACE FLIP-FLOPS WITH 3-STATE OUTPUTS

SDAS145B – JANUARY 1986 – REVISED JANUARY 1995

recommended operating conditions

		SN54ALS29821			SN74ALS29821			UNIT
		MIN	NOM	MAX	MIN	NOM	MAX	
V_{CC}	Supply voltage	4.5	5	5.5	4.75	5	5.25	V
V_{IH}	High-level input voltage	2			2			V
V_{IL}	Low-level input voltage			0.8			0.8	V
I_{OH}	High-level output current			-24			-24	mA
I_{OL}	Low-level output current			48			48	mA
t_w	Pulse duration, CLK high or low	7			7			ns
t_{su}	Setup time, data before CLK \uparrow	4			4			ns
t_h	Hold time, data after CLK \uparrow	2			2			ns
T_A	Operating free-air temperature	-55		125	0		70	°C

electrical characteristics over recommended operating free-air temperature range (unless otherwise noted)

PARAMETER	TEST CONDITIONS		SN54ALS29821			SN74ALS29821			UNIT	
			MIN	TYP \dagger	MAX	MIN	TYP \dagger	MAX		
V_{IK}	$V_{CC} = 4.75\text{ V}$,	$I_I = -18\text{ mA}$			-1.2			-1.2	V	
V_{OH}	$V_{CC} = 4.75\text{ V}$	$I_{OH} = -15\text{ mA}$	2.4	3.3		2.4	3.3		V	
		$I_{OH} = -24\text{ mA}$	2	3.1		2	3.1			
V_{OL}	$V_{CC} = 4.75\text{ V}$,	$I_{OL} = 48\text{ mA}$			0.35			0.35	0.5	V
I_{OZH}	$V_{CC} = 5.25\text{ V}$,	$V_O = 2.4\text{ V}$			50			20	μA	
I_{OZL}	$V_{CC} = 5.25\text{ V}$,	$V_O = 0.4\text{ V}$			-50			-20	μA	
I_I	$V_{CC} = 5.25\text{ V}$,	$V_I = 5.5\text{ V}$			0.1			0.1	mA	
I_{IH}	$V_{CC} = 5.25\text{ V}$,	$V_I = 2.7\text{ V}$			20			20	μA	
I_{IL}	$V_{CC} = 5.25\text{ V}$,	$V_I = 0.4\text{ V}$			-0.5			-0.2	mA	
I_{OS}^\ddagger	$V_{CC} = 5.25\text{ V}$,	$V_O = 0$			-75			-250	mA	
I_{CC}	$V_{CC} = 5.25\text{ V}$,	Outputs open			80			115	mA	

\dagger All typical values are at $V_{CC} = 5\text{ V}$, $T_A = 25^\circ\text{C}$.

\ddagger Not more than one output should be shorted at a time, and the duration of the short circuit should not exceed one second.



SN54ALS29821, SN74ALS29821 10-BIT BUS-INTERFACE FLIP-FLOPS WITH 3-STATE OUTPUTS

SDAS145B – JANUARY 1986 – REVISED JANUARY 1995

switching characteristics (see Figure 1)

PARAMETER	FROM (INPUT)	TO (OUTPUT)	TEST CONDITIONS	V _{CC} = MIN to MAX†, T _A = MIN to MAX†				UNIT
				SN54ALS29821		SN74ALS29821		
				MIN	MAX	MIN	MAX	
t _{PLH}	CLK	Any Q	C _L = 50 pF	2	11.5	2	10	ns
t _{PHL}				2	11.5	2	10	
t _{PLH}	CLK	Any Q	C _L = 300 pF	2	21	16		ns
t _{PHL}				2	21	16		
t _{PZH}	\overline{OE}	Any Q	C _L = 50 pF	1	17	14		ns
t _{PZL}				1	17	14		
t _{PZH}	\overline{OE}	Any Q	C _L = 300 pF	1	25	20		ns
t _{PZL}				1	29.5	23		
t _{PHZ}	\overline{OE}	Any Q	C _L = 50 pF	1	16	14		ns
t _{PLZ}				1	14	12		
t _{PHZ}	\overline{OE}	Any Q	C _L = 5 pF	1	12	9		ns
t _{PLZ}				1	11	9		

† For conditions shown as MIN or MAX, use the appropriate value specified under recommended operating conditions.



PARAMETER MEASUREMENT INFORMATION

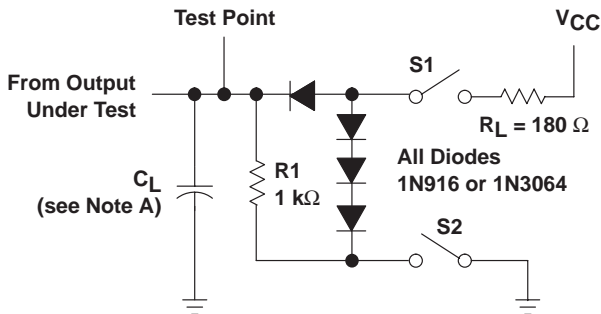

LOAD CIRCUIT

SWITCH POSITION TABLE

TEST	S1	S2
t _{PLH}	Closed	Closed
t _{PHL}	Closed	Closed
t _{PZH}	Open	Closed
t _{PZL}	Closed	Open
t _{PHZ}	Closed	Closed
t _{PLZ}	Closed	Closed

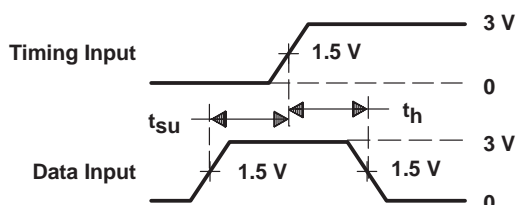

VOLTAGE WAVEFORMS
SETUP AND HOLD TIMES

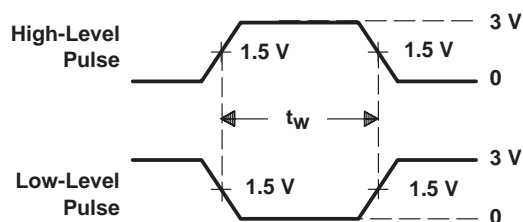

VOLTAGE WAVEFORMS
PULSE DURATIONS

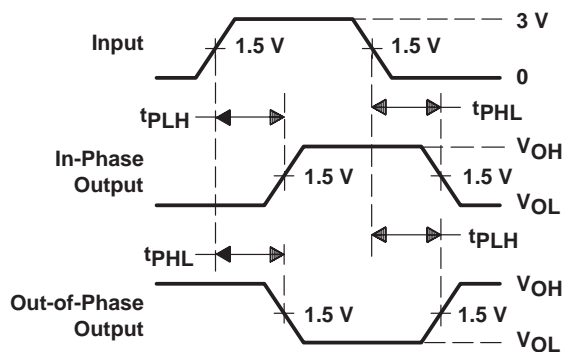

VOLTAGE WAVEFORMS
PROPAGATION DELAY TIMES

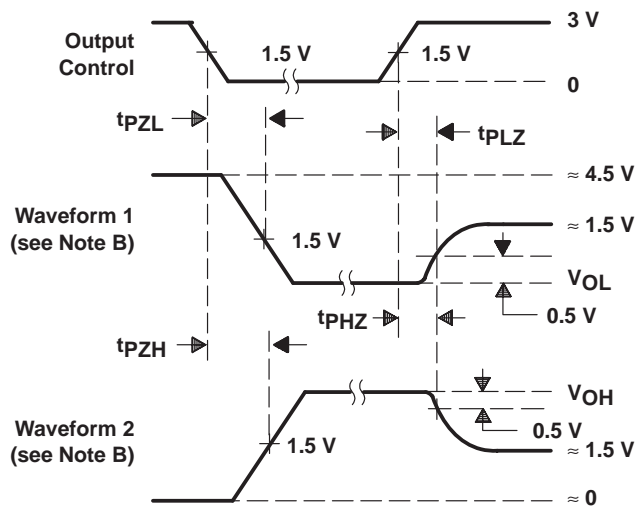

VOLTAGE WAVEFORMS
ENABLE AND DISABLE TIMES, 3-STATE OUTPUTS

- NOTES: A. C_L includes probe and jig capacitance.
B. Waveform 1 is for an output with internal conditions such that the output is low except when disabled by the output control. Waveform 2 is for an output with internal conditions such that the output is high except when disabled by the output control.
C. All input pulses are supplied by generators having the following characteristics: PRR \leq 10 MHz, $Z_O = 50 \Omega$, $t_r \leq 2.5$ ns, $t_f \leq 2.5$ ns.

Figure 1. Load Circuit and Voltage Waveforms

PACKAGING INFORMATION

Orderable Device	Status (1)	Package Type	Package Drawing	Pins	Package Qty	Eco Plan (2)	Lead finish/ Ball material (6)	MSL Peak Temp (3)	Op Temp (°C)	Device Marking (4/5)	Samples
5962-9061601LA	ACTIVE	CDIP	JT	24	15	Non-RoHS & Green	SNPB	N / A for Pkg Type	-55 to 125	5962-9061601LA SNJ54ALS29821J T	Samples
SN74ALS29821DW	ACTIVE	SOIC	DW	24	25	RoHS & Green	NIPDAU	Level-1-260C-UNLIM	0 to 70	ALS29821	Samples
SNJ54ALS29821JT	ACTIVE	CDIP	JT	24	15	Non-RoHS & Green	SNPB	N / A for Pkg Type	-55 to 125	5962-9061601LA SNJ54ALS29821J T	Samples

(1) The marketing status values are defined as follows:

ACTIVE: Product device recommended for new designs.

LIFEBUY: TI has announced that the device will be discontinued, and a lifetime-buy period is in effect.

NRND: Not recommended for new designs. Device is in production to support existing customers, but TI does not recommend using this part in a new design.

PREVIEW: Device has been announced but is not in production. Samples may or may not be available.

OBSOLETE: TI has discontinued the production of the device.

(2) **RoHS:** TI defines "RoHS" to mean semiconductor products that are compliant with the current EU RoHS requirements for all 10 RoHS substances, including the requirement that RoHS substance do not exceed 0.1% by weight in homogeneous materials. Where designed to be soldered at high temperatures, "RoHS" products are suitable for use in specified lead-free processes. TI may reference these types of products as "Pb-Free".

RoHS Exempt: TI defines "RoHS Exempt" to mean products that contain lead but are compliant with EU RoHS pursuant to a specific EU RoHS exemption.

Green: TI defines "Green" to mean the content of Chlorine (Cl) and Bromine (Br) based flame retardants meet JS709B low halogen requirements of <=1000ppm threshold. Antimony trioxide based flame retardants must also meet the <=1000ppm threshold requirement.

(3) MSL, Peak Temp. - The Moisture Sensitivity Level rating according to the JEDEC industry standard classifications, and peak solder temperature.

(4) There may be additional marking, which relates to the logo, the lot trace code information, or the environmental category on the device.

(5) Multiple Device Markings will be inside parentheses. Only one Device Marking contained in parentheses and separated by a "~" will appear on a device. If a line is indented then it is a continuation of the previous line and the two combined represent the entire Device Marking for that device.

(6) Lead finish/Ball material - Orderable Devices may have multiple material finish options. Finish options are separated by a vertical ruled line. Lead finish/Ball material values may wrap to two lines if the finish value exceeds the maximum column width.

Important Information and Disclaimer:The information provided on this page represents TI's knowledge and belief as of the date that it is provided. TI bases its knowledge and belief on information provided by third parties, and makes no representation or warranty as to the accuracy of such information. Efforts are underway to better integrate information from third parties. TI has taken and

continues to take reasonable steps to provide representative and accurate information but may not have conducted destructive testing or chemical analysis on incoming materials and chemicals. TI and TI suppliers consider certain information to be proprietary, and thus CAS numbers and other limited information may not be available for release.

In no event shall TI's liability arising out of such information exceed the total purchase price of the TI part(s) at issue in this document sold by TI to Customer on an annual basis.

OTHER QUALIFIED VERSIONS OF SN54ALS29821, SN74ALS29821 :

- Catalog : [SN74ALS29821](#)
- Military : [SN54ALS29821](#)

NOTE: Qualified Version Definitions:

- Catalog - TI's standard catalog product
- Military - QML certified for Military and Defense Applications

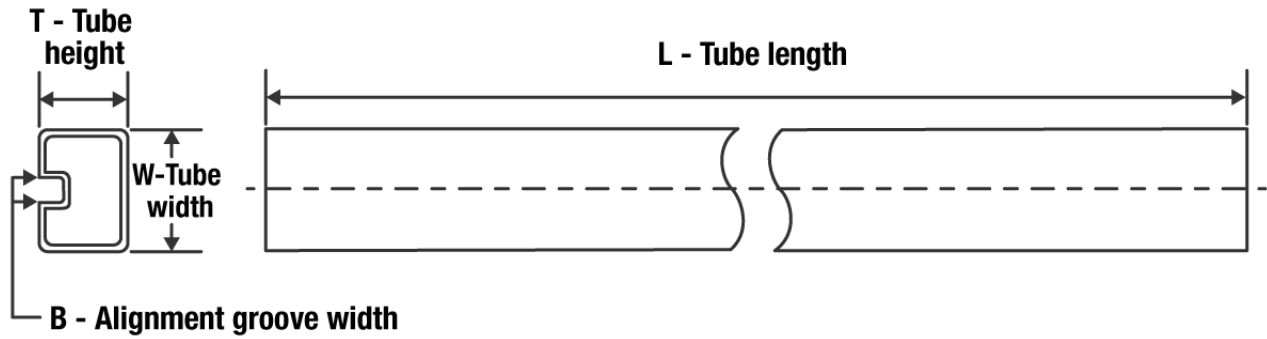
TUBE

*All dimensions are nominal

Device	Package Name	Package Type	Pins	SPQ	L (mm)	W (mm)	T (μm)	B (mm)
SN74ALS29821DW	DW	SOIC	24	25	506.98	12.7	4826	6.6

JT (R-GDIP-T**)

CERAMIC DUAL-IN-LINE

24 LEADS SHOWN



- NOTES: A. All linear dimensions are in inches (millimeters).
 B. This drawing is subject to change without notice.
 C. This package can be hermetically sealed with a ceramic lid using glass frit.
 D. Index point is provided on cap for terminal identification.
 E. Falls within MIL STD 1835 GDIP3-T24, GDIP4-T28, and JEDEC MO-058 AA, MO-058 AB

DW (R-PDSO-G24)

PLASTIC SMALL OUTLINE

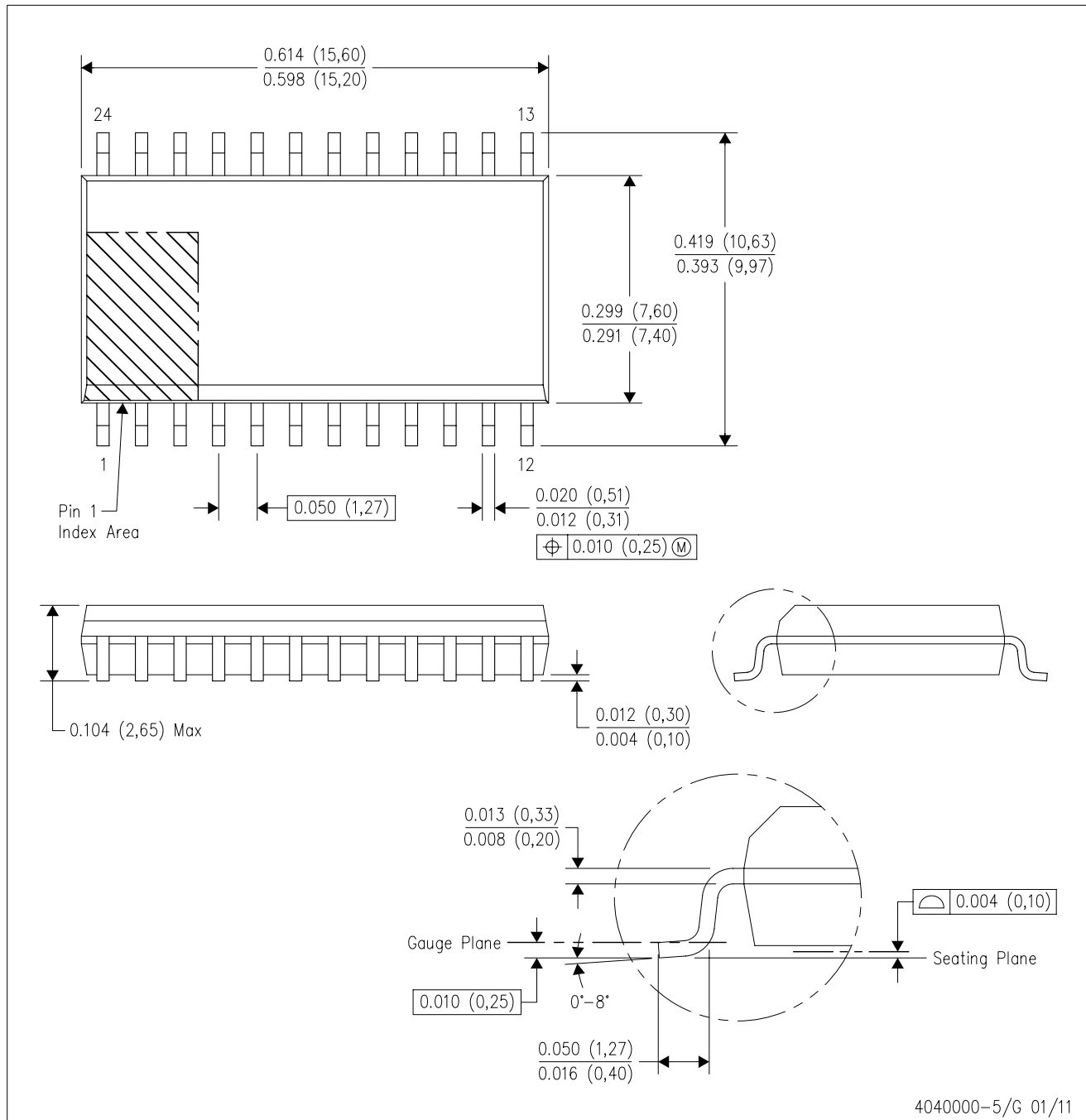

- NOTES:
- All linear dimensions are in inches (millimeters). Dimensioning and tolerancing per ASME Y14.5M-1994.
 - This drawing is subject to change without notice.
 - Body dimensions do not include mold flash or protrusion not to exceed 0.006 (0,15).
 - Falls within JEDEC MS-013 variation AD.

IMPORTANT NOTICE AND DISCLAIMER

TI PROVIDES TECHNICAL AND RELIABILITY DATA (INCLUDING DATA SHEETS), DESIGN RESOURCES (INCLUDING REFERENCE DESIGNS), APPLICATION OR OTHER DESIGN ADVICE, WEB TOOLS, SAFETY INFORMATION, AND OTHER RESOURCES "AS IS" AND WITH ALL FAULTS, AND DISCLAIMS ALL WARRANTIES, EXPRESS AND IMPLIED, INCLUDING WITHOUT LIMITATION ANY IMPLIED WARRANTIES OF MERCHANTABILITY, FITNESS FOR A PARTICULAR PURPOSE OR NON-INFRINGEMENT OF THIRD PARTY INTELLECTUAL PROPERTY RIGHTS.

These resources are intended for skilled developers designing with TI products. You are solely responsible for (1) selecting the appropriate TI products for your application, (2) designing, validating and testing your application, and (3) ensuring your application meets applicable standards, and any other safety, security, regulatory or other requirements.

These resources are subject to change without notice. TI grants you permission to use these resources only for development of an application that uses the TI products described in the resource. Other reproduction and display of these resources is prohibited. No license is granted to any other TI intellectual property right or to any third party intellectual property right. TI disclaims responsibility for, and you will fully indemnify TI and its representatives against, any claims, damages, costs, losses, and liabilities arising out of your use of these resources.

TI's products are provided subject to [TI's Terms of Sale](#) or other applicable terms available either on [ti.com](https://www.ti.com) or provided in conjunction with such TI products. TI's provision of these resources does not expand or otherwise alter TI's applicable warranties or warranty disclaimers for TI products.

TI objects to and rejects any additional or different terms you may have proposed.

Mailing Address: Texas Instruments, Post Office Box 655303, Dallas, Texas 75265
Copyright © 2023, Texas Instruments Incorporated

Looking for pricing, stock, or lifecycle information?

Click below to explore more details on WIN SOURCE:

 [View SN74ALS29821DW on WIN SOURCE](#)

 [Texas Instruments](#) Information

Optimize Your Supply Chain with WIN SOURCE Solutions

-  Global Sourcing Solution
-  Obsolete Management
-  Cost Control Management
-  Shortage Management
-  Alternative Solution
-  Excess Inventory Management