



**THE DATASHEET OF
CY8C21223-24LGXIT**



Features

- Powerful Harvard-architecture processor:
 - M8C processor speeds up to 24 MHz
 - Low power at high speed
 - Operating voltage: 2.4 V to 5.25 V
 - Operating voltages down to 1.0 V using on-chip switch mode pump (SMP)
 - Industrial temperature range: -40 °C to +85 °C
- Advanced peripherals (PSoC® blocks):
 - Four analog type “E” PSoC blocks provide:
 - Two comparators with digital to analog converter (DAC) references
 - Single or dual 10-Bit 8-to-1 analog to digital converter (ADC)
 - Four digital PSoC blocks provide:
 - 8- to 32-bit timers and counters, 8- and 16-bit pulse-width modulators (PWMs)
 - CRC and PRS modules
 - Full duplex UART, SPI™ master or slave: Connectable to all general-purpose I/O (GPIO) pins
 - Complex peripherals by combining blocks
- Flexible on-chip memory:
 - 4 KB flash program storage 50,000 erase/write cycles
 - 256 bytes SRAM data storage
 - In-system serial programming (ISSP)
 - Partial flash updates
 - Flexible protection modes
 - EEPROM emulation in flash
- Complete development tools:
 - Free development software (PSoC Designer™)
 - Full-featured, in-circuit emulator (ICE) and programmer
 - Full-speed emulation
 - Complex breakpoint structure
 - 128-KB trace memory
- Precision, programmable clocking:
 - Internal ±5% 24- / 48-MHz main oscillator
 - Internal low-speed, low-power oscillator for watchdog and sleep functionality
- Programmable pin configurations:
 - 25-mA sink, 10-mA source on all GPIOs
 - Pull-up, pull-down, high Z, strong, or open-drain drive modes on all GPIOs
 - Up to eight analog inputs on all GPIOs
 - Configurable interrupt on all GPIOs

- Additional system resources:
 - I²C master, slave and multi-master to 400 kHz
 - Watchdog and sleep timers
 - User-configurable low-voltage detection (LVD)
 - Integrated supervisory circuit
 - On-chip precision voltage reference

Logic Block Diagram

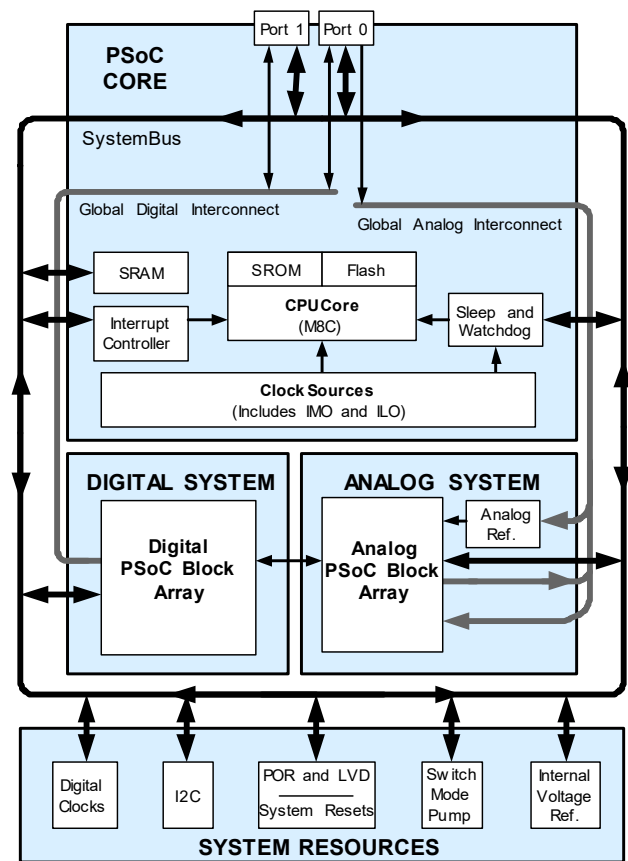

Errata: When the device is operated within 0 °C to 70 °C, the frequency tolerance is reduced to ±2.5%, but if operated at extreme temperature (below 0 °C or above 70 °C), frequency tolerance deviates from ±2.5% to ±5%. For information on silicon errata, see “Errata” on page 43.

Contents

PSoC Functional Overview	3	Absolute Maximum Ratings	16
PSoC Core	3	Operating Temperature	17
Digital System	3	DC Electrical Characteristics	17
Analog System	4	AC Electrical Characteristics	23
Additional System Resources	4	Packaging Information	31
PSoC Device Characteristics	5	Packaging Dimensions	31
Getting Started	5	Thermal Impedances	35
Application Notes	5	Solder Reflow Specifications	35
Development Kits	5	Ordering Information	36
Training	5	Ordering Code Definitions	36
CYPros Consultants	5	Acronyms	37
Solutions Library	5	Acronyms Used	37
Technical Support	5	Reference Documents	37
Development Tool Selection	6	Document Conventions	38
Software	6	Units of Measure	38
Designing with PSoC Designer	7	Numeric Conventions	38
Select Components	7	Glossary	38
Configure Components	7	Errata	43
Organize and Connect	7	Part Numbers Affected	43
Generate, Verify, and Debug	7	CY8C21123 Qualification Status	43
Pin Information	8	CY8C21123 Errata Summary	43
8-Pin Part Pinout	8	Document History Page	44
16-Pin Part Pinout	8	Sales, Solutions, and Legal Information	47
20-Pin Part Pinout	10	Worldwide Sales and Design Support	47
24-Pin Part Pinout	11	Products	47
Register Reference	12	PSoC [®] Solutions	47
Register Conventions	12	Cypress Developer Community	47
Register Mapping Tables	12	Technical Support	47
Electrical Specifications	16		

PSoC Functional Overview

The PSoC family consists of many programmable system-on-chip controller devices. These devices are designed to replace multiple traditional MCU-based system components with a low cost single-chip programmable component. A PSoC device includes configurable blocks of analog and digital logic, and programmable interconnect. This architecture allows you to create customized peripheral configurations, to match the requirements of each individual application. Additionally, a fast CPU, Flash program memory, SRAM data memory, and configurable I/O are included in a range of convenient pinouts.

The PSoC architecture, as shown in [Figure 1](#), consists of four main areas: the Core, the System Resources, the Digital System, and the Analog System. Configurable global bus resources allow the combining of all device resources into a complete custom system. Each PSoC device includes four digital blocks. Depending on the PSoC package, up to two analog comparators and up to 16 GPIO are also included. The GPIO provide access to the global digital and analog interconnects.

PSoC Core

The PSoC Core is a powerful engine that supports a rich instruction set. It encompasses SRAM for data storage, an interrupt controller, sleep and watchdog timers, and internal main oscillator (IMO), and internal low-speed oscillator (ILO). The CPU core, called the M8C, is a powerful processor with speeds up to 24 MHz. The M8C is a four MIPS 8-bit Harvard-architecture microprocessor.

System Resources provide additional capability, such as digital clocks or I²C functionality for implementing an I²C master, slave, MultiMaster, an internal voltage reference that provides an absolute value of 1.3 V to a number of PSoC subsystems, an SMP that generates normal operating voltages off a single battery cell, and various system resets supported by the M8C.

The digital system consists of an array of digital PSoC blocks, which can be configured into any number of digital peripherals. The digital blocks can be connected to the GPIO through a series of global bus that can route any signal to any pin. This frees designs from the constraints of a fixed peripheral controller.

The analog system consists of four analog PSoC blocks, supporting comparators and analog-to-digital conversion up to 10 bits of precision.

Digital System

The digital system consists of four digital PSoC blocks. Each block is an 8-bit resource that can be used alone or combined with other blocks to form 8, 16, 24, and 32-bit peripherals, which are called user modules. Digital peripheral configurations include:

- PWMs (8- and 16-bit)
- PWMs with dead band (8- and 16-bit)
- Counters (8- to 32-bit)
- Timers (8- to 32-bit)
- UART 8-bit with selectable parity (up to two)
- SPI master and slave
- I²C slave, master, multi-master (one available as a system resource)
- Cyclical redundancy checker/generator (8-bit)
- IrDA (up to two)
- Pseudo random sequence generators (8- to 32-bit)

The digital blocks can be connected to any GPIO through a series of global bus that can route any signal to any pin. The busses also allow for signal multiplexing and performing logic operations. This configurability frees your designs from the constraints of a fixed peripheral controller.

Digital blocks are provided in rows of four, where the number of blocks varies by PSoC device family. This provides an optimum choice of system resources for your application. Family resources are shown in [Table 1 on page 5](#).

Figure 1. Digital System Block Diagram

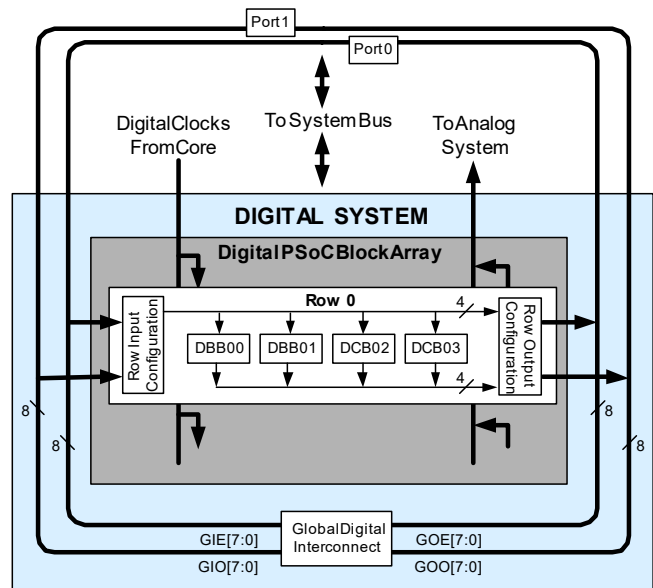

Analog System

The analog system consists of four configurable blocks to allow creation of complex analog signal flows. Analog peripherals are very flexible and may be customized to support specific application requirements. Some of the more common PSoC analog functions (most available as user modules) are:

- Analog-to-digital converters (single or dual, with 8-bit or 10-bit resolution)
- Pin-to-pin comparators (one)
- Single-ended comparators (up to 2) with absolute (1.3 V) reference or 8-bit DAC reference
- 1.3 V reference (as a system resource)

In most PSoC devices, analog blocks are provided in columns of three, which includes one CT (continuous time) and two SC (switched capacitor) blocks. The CY8C21x23 devices provide limited functionality Type “E” analog blocks. Each column contains one CT block and one SC block.

The number of blocks on the device family is listed in [Table 1 on page 5](#).

Figure 2. CY8C21x23 Analog System Block Diagram

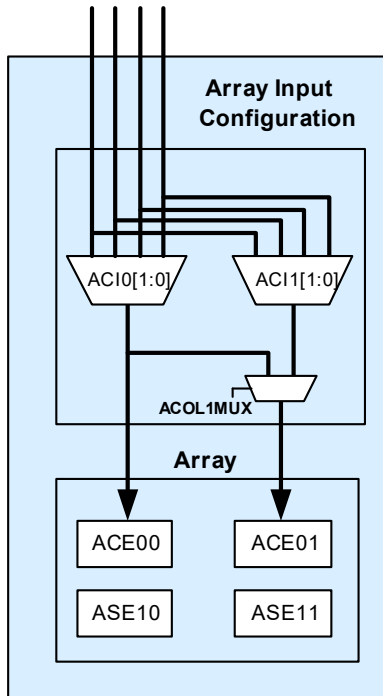

Additional System Resources

System resources, some of which listed in the previous sections, provide additional capability useful to complete systems. Additional resources include a switch mode pump, low voltage detection, and power on reset. The merits of each system resource are.

- Digital clock dividers provide three customizable clock frequencies for use in applications. The clocks can be routed to both the digital and analog systems. Additional clocks can be generated using digital PSoC blocks as clock dividers.
- The I²C module provides 100 and 400 kHz communication over two wires. Slave, master, and multi-master modes are all supported.
- LVD interrupts can signal the application of falling voltage levels, while the advanced POR (power on reset) circuit eliminates the need for a system supervisor.
- An internal 1.3 V voltage reference provides an absolute reference for the analog system, including ADCs and DACs.
- An integrated switch mode pump (SMP) generates normal operating voltages from a single 1.2 V battery cell, providing a low cost boost converter.

PSoC Device Characteristics

Depending on your PSoC device characteristics, the digital and analog systems can have 16, 8, or 4 digital blocks, and 12, 6, or 4 analog blocks. Table 1 lists the resources available for specific PSoC device groups. The PSoC device covered by this datasheet is highlighted.

Table 1. PSoC Device Characteristics

PSoC Part Number	Digital I/O	Digital Rows	Digital Blocks	Analog Inputs	Analog Outputs	Analog Columns	Analog Blocks	SRAM Size	Flash Size
CY8C29x66	up to 64	4	16	up to 12	4	4	12	2 K	32 K
CY8C28xxx	up to 44	up to 3	up to 12	up to 44	up to 4	up to 6	up to 12 + 4 ^[1]	1 K	16 K
CY8C27x43	up to 44	2	8	up to 12	4	4	12	256	16 K
CY8C24x94	up to 56	1	4	up to 48	2	2	6	1 K	16 K
CY8C24x23A	up to 24	1	4	up to 12	2	2	6	256	4 K
CY8C23x33	up to 26	1	4	up to 12	2	2	4	256	8 K
CY8C22x45	up to 38	2	8	up to 38	0	4	6 ^[1]	1 K	16 K
CY8C21x45	up to 24	1	4	up to 24	0	4	6 ^[1]	512	8 K
CY8C21x34	up to 28	1	4	up to 28	0	2	4 ^[1]	512	8 K
CY8C21x23	up to 16	1	4	up to 8	0	2	4 ^[1]	256	4 K
CY8C20x34	up to 28	0	0	up to 28	0	0	3 ^[1,2]	512	8 K
CY8C20xx6	up to 36	0	0	up to 36	0	0	3 ^[1,2]	up to 2 K	up to 32 K

Getting Started

The quickest way to understand PSoC silicon is to read this datasheet and then use the PSoC Designer Integrated Development Environment (IDE). This datasheet is an overview of the PSoC integrated circuit and presents specific pin, register, and electrical specifications.

For in depth information, along with detailed programming details, see the [Technical Reference Manual](#) for this PSoC device.

For up to date ordering, packaging, and electrical specification information, see the latest PSoC device datasheets on the web at <http://www.cypress.com>.

Application Notes

Application notes are an excellent introduction to the wide variety of possible PSoC designs. They can be found at <http://www.cypress.com>.

Development Kits

PSoC Development Kits are available online from Cypress at <http://www.cypress.com> and through a growing number of regional and global distributors, which include Arrow, Avnet, Digi-Key, Farnell, Future Electronics, and Newark.

Training

Free PSoC technical training (on demand, webinars, and workshops) is available online at <http://www.cypress.com>. The training covers a wide variety of topics and skill levels to assist you in your designs.

CYPros Consultants

Certified PSoC Consultants offer everything from technical assistance to completed PSoC designs. To contact or become a PSoC Consultant go to <http://www.cypress.com> and refer to CYPros Consultants.

Solutions Library

Visit our growing library of solution focused designs at <http://www.cypress.com>. Here you can find various application designs that include firmware and hardware design files that enable you to complete your designs quickly.

Technical Support

For assistance with technical issues, search KnowledgeBase articles and forums at <http://www.cypress.com>. If you cannot find an answer to your question, call technical support at 1-800-541-4736.

Notes

1. Limited analog functionality.
2. Two analog blocks and one CapSense®.

Development Tool Selection

Software

PSoC Designer

At the core of the PSoC development software suite is PSoC Designer. Utilized by thousands of PSoC developers, this robust software has been facilitating PSoC designs for years. PSoC Designer is available free of charge at <http://www.cypress.com>. PSoC Designer comes with a free C compiler.

PSoC Designer Software Subsystems

You choose a base device to work with and then select different onboard analog and digital components called user modules that use the PSoC blocks. Examples of user modules are ADCs, DACs, Amplifiers, and Filters. You configure the user modules for your chosen application and connect them to each other and to the proper pins. Then you generate your project. This prepopulates your project with APIs and libraries that you can use to program your application.

The tool also supports easy development of multiple configurations and dynamic reconfiguration. Dynamic reconfiguration allows for changing configurations at run time. Code Generation Tools PSoC Designer supports multiple third-party C compilers and assemblers. The code generation tools work seamlessly within the PSoC Designer interface and have been tested with a full range of debugging tools. The choice is yours.

Assemblers. The assemblers allow assembly code to be merged seamlessly with C code. Link libraries automatically use absolute addressing or are compiled in relative mode, and linked with other software modules to get absolute addressing.

C Language Compilers. C language compilers are available that support the PSoC family of devices. The products allow you to create complete C programs for the PSoC family devices. The optimizing C compilers provide all the features of C tailored to the PSoC architecture. They come complete with embedded libraries providing port and bus operations, standard keypad and display support, and extended math functionality.

Debugger

PSoC Designer has a debug environment that provides hardware in-circuit emulation, allowing you to test the program in a physical system while providing an internal view of the PSoC device. Debugger commands allow the designer to read and program and read and write data memory, read and write I/O registers, read and write CPU registers, set and clear breakpoints, and provide program run, halt, and step control. The debugger also allows the designer to create a trace buffer of registers and memory locations of interest.

In-Circuit Emulator

A low cost, high functionality In-Circuit Emulator (ICE) is available for development support. This hardware has the capability to program single devices. The emulator consists of a base unit that connects to the PC by way of a USB port. The base unit is universal and operates with all PSoC devices. Emulation pods for each device family are available separately. The emulation pod takes the place of the PSoC device in the target board and performs full speed (24MHz) operation.

Standard Cypress PSoC IDE tools are available for debugging the CY8C20x36A/66A family of parts. However, the additional trace length and a minimal ground plane in the Flex-Pod can create noise problems that make it difficult to debug the design. A custom bonded On-Chip Debug (OCD) device is available in a 48-pin QFN package. The OCD device is recommended for debugging designs that have high current and/or high analog accuracy requirements. The QFN package is compact and is connected to the ICE through a high density connector.

PSoC Programmer

Flexible enough to be used on the bench in development, yet suitable for factory programming, PSoC Programmer works either as a standalone programming application or it can operate directly from PSoC Designer. PSoC Programmer software is compatible with both PSoC ICE-Cube in-circuit emulator and PSoC MiniProg. PSoC programmer is available free of charge at <http://www.cypress.com/psocprogrammer>.

Designing with PSoC Designer

The development process for the PSoC device differs from that of a traditional fixed function microprocessor. The configurable analog and digital hardware blocks give the PSoC architecture a unique flexibility that pays dividends in managing specification change during development and by lowering inventory costs. These configurable resources, called PSoC Blocks, have the ability to implement a wide variety of user-selectable functions.

The PSoC development process can be summarized in the following four steps:

1. Select [User Modules](#)
2. Configure User Modules
3. Organize and Connect
4. Generate, Verify, and Debug

Select Components

PSoC Designer provides a library of pre-built, pre-tested hardware peripheral components called "user modules." User modules make selecting and implementing peripheral devices, both analog and digital, simple.

Configure Components

Each of the User Modules you select establishes the basic register settings that implement the selected function. They also provide parameters and properties that allow you to tailor their precise configuration to your particular application. For example, a PWM User Module configures one or more

digital PSoC blocks, one for each 8 bits of resolution. The user module parameters permit you to establish the pulse width and duty cycle. Configure the parameters and properties to correspond to your chosen application. Enter values directly or by selecting values from drop-down menus. All the user modules are documented in datasheets that may be viewed directly in PSoC Designer or on the Cypress website. These [user module datasheets](#) explain the internal operation of the User Module and provide performance specifications. Each datasheet describes the use of each user module parameter, and other information you may need to successfully implement your design.

Organize and Connect

You build signal chains at the chip level by interconnecting user modules to each other and the I/O pins. You perform the selection, configuration, and routing so that you have complete control over all on-chip resources.

Generate, Verify, and Debug

When you are ready to test the hardware configuration or move on to developing code for the project, you perform the "Generate Configuration Files" step. This causes PSoC Designer to generate source code that automatically configures the device to your specification and provides the software for the system. The generated code provides application programming interfaces (APIs) with high-level functions to control and respond to hardware events at run time and interrupt service routines that you can adapt as needed.

A complete code development environment allows you to develop and customize your applications in C, assembly language, or both.

The last step in the development process takes place inside PSoC Designer's Debugger (access by clicking the Connect icon). PSoC Designer downloads the HEX image to the ICE where it runs at full speed. PSoC Designer debugging capabilities rival those of systems costing many times more. In addition to traditional single-step, run-to-breakpoint and watch-variable features, the debug interface provides a large trace buffer and allows you to define complex breakpoint events that include monitoring address and data bus values, memory locations and external signals.

Pin Information

This section describes, lists, and illustrates the CY8C21x23 PSoC device pins and pinout configurations. Every port pin (labeled with a "P") is capable of Digital I/O. However, V_{SS}, V_{DD}, SMP, and XRES are not capable of Digital I/O.

8-Pin Part Pinout

Table 2. Pin Definitions – CY8C21123 8-Pin SOIC

Pin No.	Type		Pin Name	Description
	Digital	Analog		
1	I/O	I	P0[5]	Analog column mux input
2	I/O	I	P0[3]	Analog column mux input
3	I/O		P1[1]	I ² C serial clock (SCL), ISSP-SCLK ^[3]
4	Power		V _{SS}	Ground connection
5	I/O		P1[0]	I ² C serial data (SDA), ISSP-SDATA ^[3]
6	I/O	I	P0[2]	Analog column mux input
7	I/O	I	P0[4]	Analog column mux input
8	Power		V _{DD}	Supply voltage

LEGEND: A = Analog, I = Input, and O = Output.

Figure 3. CY8C21123 8-Pin SOIC

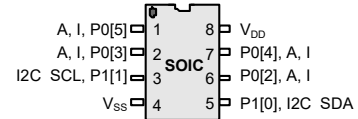

16-Pin Part Pinout

Table 3. Pin Definitions – CY8C21223 16-Pin SOIC

Pin No.	Type		Pin Name	Description
	Digital	Analog		
1	I/O	I	P0[7]	Analog column mux input
2	I/O	I	P0[5]	Analog column mux input
3	I/O	I	P0[3]	Analog column mux input
4	I/O	I	P0[1]	Analog column mux input
5	Power		SMP	SMP connection to required external components
6	Power		V _{SS}	Ground connection
7	I/O		P1[1]	I ² C SCL, ISSP-SCLK ^[3]
8	Power		V _{SS}	Ground connection
9	I/O		P1[0]	I ² C SDA, ISSP-SDATA ^[3]
10	I/O		P1[2]	
11	I/O		P1[4]	Optional external clock input (EXTCLK)
12	I/O	I	P0[0]	Analog column mux input
13	I/O	I	P0[2]	Analog column mux input
14	I/O	I	P0[4]	Analog column mux input
15	I/O	I	P0[6]	Analog column mux input
16	Power		V _{DD}	Supply voltage

LEGEND A = Analog, I = Input, and O = Output.

Figure 4. CY8C21223 16-Pin SOIC

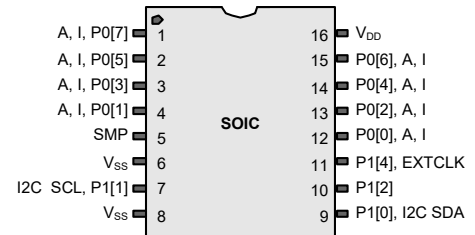

Note

3. These are the ISSP pins, which are not high Z at POR (power on reset). See the [PSoC Technical Reference Manual](#) for details.

Table 4. Pin Definitions – CY8C21223 16-Pin QFN with no E-Pad ^[4]

Pin No.	Type		Pin Name	Description
	Digital	Analog		
1	I/O	I	P0[3]	Analog column mux input
2	I/O	I	P0[1]	Analog column mux input
3	I/O		P1[7]	I ² C SCL
4	I/O		P1[5]	I ² C SDA
5	I/O		P1[3]	
6	I/O		P1[1]	I ² C SCL, ISSP-SCLK ^[5]
7	Power		V _{SS}	Ground connection
8	I/O		P1[0]	I ² C SDA, ISSP-SDATA ^[5]
9	I/O		P1[6]	
10	I/O		P1[4]	EXTCLK
11	Input		XRES	Active high external reset with internal pull-down
12	I/O	I	P0[4]	V _{REF}
13	Power		V _{DD}	Supply voltage
14	I/O	I	P0[7]	Analog column mux input
15	I/O	I	P0[5]	Analog column mux input
16			NC	No Connection. Pin must be left floating

LEGEND A = Analog, I = Input, and O = Output.

Figure 5. CY8C21223 16-Pin QFN

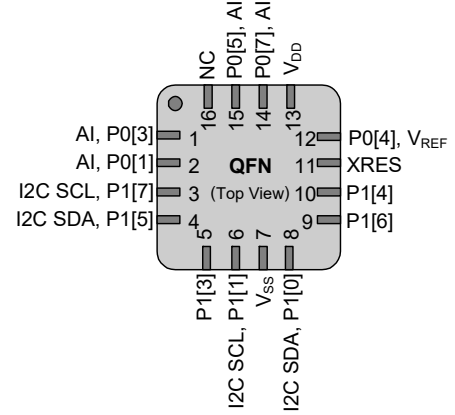

Notes

- The center pad on the QFN package must be connected to ground (V_{SS}) for best mechanical, thermal, and electrical performance. If not connected to ground, it must be electrically floated and not connected to any other signal.
- These are the ISSP pins, which are not high Z at POR (power on reset). See the [PSoC Technical Reference Manual](#) for details.

20-Pin Part Pinout
Table 5. Pin Definitions – CY8C21323 20-Pin SSOP

Pin No.	Type		Pin Name	Description
	Digital	Analog		
1	I/O	I	P0[7]	Analog column mux input
2	I/O	I	P0[5]	Analog column mux input
3	I/O	I	P0[3]	Analog column mux input
4	I/O	I	P0[1]	Analog column mux input
5	Power		V _{SS}	Ground connection ^[6]
6	I/O		P1[7]	I ² C SCL
7	I/O		P1[5]	I ² C SDA
8	I/O		P1[3]	
9	I/O		P1[1]	I ² C SCL, ISSP-SCLK ^[7]
10	Power		V _{SS}	Ground connection ^[6]
11	I/O		P1[0]	I ² C SDA, ISSP-SDATA ^[7]
12	I/O		P1[2]	
13	I/O		P1[4]	Optional EXTCLK input
14	I/O		P1[6]	
15	Input		XRES	Active high external reset with internal pull-down
16	I/O	I	P0[0]	Analog column mux input
17	I/O	I	P0[2]	Analog column mux input
18	I/O	I	P0[4]	Analog column mux input
19	I/O	I	P0[6]	Analog column mux input
20	Power		V _{DD}	Supply voltage

LEGEND A = Analog, I = Input, and O = Output.

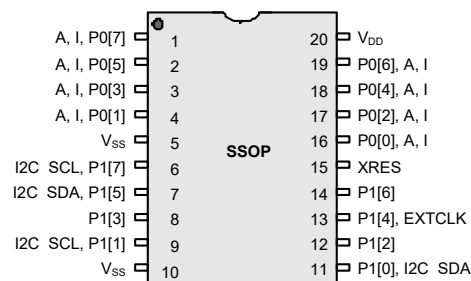
Figure 6. CY8C21323 20-Pin SSOP

Notes

- All V_{SS} pins should be brought out to one common GND plane.
- These are the ISSP pins, which are not high Z at POR (power on reset). See the [PSoC Technical Reference Manual](#) for details.

24-Pin Part Pinout

Table 6. Pin Definitions – CY8C21323 24-Pin QFN^[8]

Pin No.	Type		Pin Name	Description
	Digital	Analog		
1	I/O	I	P0[1]	Analog column mux input
2	Power		SMP	SMP connection to required external components
3	Power		V _{SS}	Ground connection ^[9]
4	I/O		P1[7]	I ² C SCL
5	I/O		P1[5]	I ² C SDA
6	I/O		P1[3]	
7	I/O		P1[1]	I ² C SCL, ISSP-SCLK ^[10]
8			NC	No connection. Pin must be left floating
9	Power		V _{SS}	Ground connection ^[9]
10	I/O		P1[0]	I ² C SDA, ISSP-SDATA ^[10]
11	I/O		P1[2]	
12	I/O		P1[4]	Optional (EXTCLK) input
13	I/O		P1[6]	
14	Input		XRES	Active high external reset with internal pull-down
15			NC	No connection. Pin must be left floating
16	I/O	I	P0[0]	Analog column mux input
17	I/O	I	P0[2]	Analog column mux input
18	I/O	I	P0[4]	Analog column mux input
19	I/O	I	P0[6]	Analog column mux input
20	Power		V _{DD}	Supply voltage
21	Power		V _{SS}	Ground connection ^[9]
22	I/O	I	P0[7]	Analog column mux input
23	I/O	I	P0[5]	Analog column mux input
24	I/O	I	P0[3]	Analog column mux input

LEGEND A = Analog, I = Input, and O = Output.

Figure 7. CY8C21323 24-Pin QFN

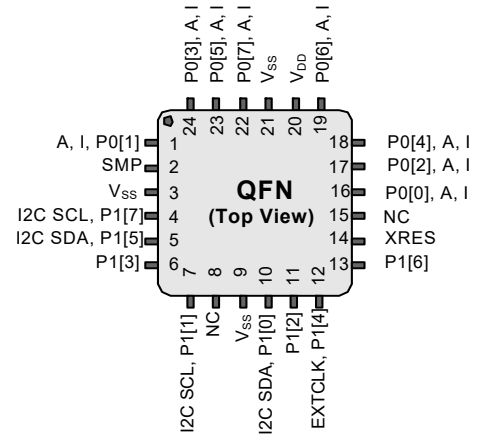

Notes

- 8. The center pad on the QFN package must be connected to ground (V_{SS}) for best mechanical, thermal, and electrical performance. If not connected to ground, it must be electrically floated and not connected to any other signal.
- 9. All V_{SS} pins should be brought out to one common GND plane.
- 10. These are the ISSP pins, which are not high Z at POR (power on reset). See the [PSoC Technical Reference Manual](#) for details.

Register Reference

This section lists the registers of the CY8C21x23 PSoC device. For detailed register information, refer the [PSoC Technical Reference Manual](#).

Register Conventions

The register conventions specific to this section are listed in [Table 7](#).

Table 7. Register Conventions

Convention	Description
R	Read register or bit(s)
W	Write register or bit(s)
L	Logical register or bit(s)
C	Clearable register or bit(s)
#	Access is bit specific

Register Mapping Tables

The PSoC device has a total register address space of 512 bytes. The register space is referred to as I/O space and is divided into two banks. The XOI bit in the Flag register (CPU_F) determines the bank you are currently in. When the XOI bit is set, you are in Bank 1.

Note In the following register mapping tables, blank fields are Reserved and must not be accessed.

Table 8. Register Map Bank 0 Table: User Space

Name	Addr (0,Hex)	Access	Name	Addr (0,Hex)	Access	Name	Addr (0,Hex)	Access	Name	Addr (0,Hex)	Access
PRT0DR	00	RW		40		ASE10CR0	80	RW		C0	
PRT0IE	01	RW		41			81			C1	
PRT0GS	02	RW		42			82			C2	
PRT0DM2	03	RW		43			83			C3	
PRT1DR	04	RW		44		ASE11CR0	84	RW		C4	
PRT1IE	05	RW		45			85			C5	
PRT1GS	06	RW		46			86			C6	
PRT1DM2	07	RW		47			87			C7	
	08			48			88			C8	
	09			49			89			C9	
	0A			4A			8A			CA	
	0B			4B			8B			CB	
	0C			4C			8C			CC	
	0D			4D			8D			CD	
	0E			4E			8E			CE	
	0F			4F			8F			CF	
	10			50			90			D0	
	11			51			91			D1	
	12			52			92			D2	
	13			53			93			D3	
	14			54			94			D4	
	15			55			95			D5	
	16			56			96		I2C_CFG	D6	RW
	17			57			97		I2C_SCR	D7	#
	18			58			98		I2C_DR	D8	RW
	19			59			99		I2C_MSCR	D9	#
	1A			5A			9A		INT_CLR0	DA	RW
	1B			5B			9B		INT_CLR1	DB	RW
	1C			5C			9C			DC	
	1D			5D			9D		INT_CLR3	DD	RW
	1E			5E			9E		INT_MSK3	DE	RW
	1F			5F			9F			DF	
DBB00DR0	20	#	AMX_IN	60	RW		A0		INT_MSK0	E0	RW
DBB00DR1	21	W		61			A1		INT_MSK1	E1	RW
DBB00DR2	22	RW	PWM_CR	62	RW		A2		INT_VC	E2	RC
DBB00CR0	23	#		63			A3		RES_WDT	E3	W
DBB01DR0	24	#	CMP_CR0	64	#		A4			E4	
DBB01DR1	25	W		65			A5			E5	
DBB01DR2	26	RW	CMP_CR1	66	RW		A6		DEC_CR0	E6	RW
DBB01CR0	27	#		67			A7		DEC_CR1	E7	RW
DCB02DR0	28	#	ADC0_CR	68	#		A8			E8	
DCB02DR1	29	W	ADC1_CR	69	#		A9			E9	
DCB02DR2	2A	RW		6A			AA			EA	
DCB02CR0	2B	#		6B			AB			EB	
DCB03DR0	2C	#	TMP_DR0	6C	RW		AC			EC	
DCB03DR1	2D	W	TMP_DR1	6D	RW		AD			ED	
DCB03DR2	2E	RW	TMP_DR2	6E	RW		AE			EE	
DCB03CR0	2F	#	TMP_DR3	6F	RW		AF			EF	

Blank fields are Reserved and must not be accessed.

Access is bit specific.

Table 8. Register Map Bank 0 Table: User Space (continued)

Name	Addr (0,Hex)	Access	Name	Addr (0,Hex)	Access	Name	Addr (0,Hex)	Access	Name	Addr (0,Hex)	Access
	30			70		RDI0RI	B0	RW		F0	
	31			71		RDI0SYN	B1	RW		F1	
	32		ACE00CR1	72	RW	RDI0IS	B2	RW		F2	
	33		ACE00CR2	73	RW	RDI0LT0	B3	RW		F3	
	34			74		RDI0LT1	B4	RW		F4	
	35			75		RDI0RO0	B5	RW		F5	
	36		ACE01CR1	76	RW	RDI0RO1	B6	RW		F6	
	37		ACE01CR2	77	RW		B7		CPU_F	F7	RL
	38			78			B8			F8	
	39			79			B9			F9	
	3A			7A			BA			FA	
	3B			7B			BB			FB	
	3C			7C			BC			FC	
	3D			7D			BD			FD	
	3E			7E			BE		CPU_SCR1	FE	#
	3F			7F			BF		CPU_SCR0	FF	#

Blank fields are Reserved and must not be accessed.

Access is bit specific.

Table 9. Register Map Bank 1 Table: Configuration Space

Name	Addr (1,Hex)	Access	Name	Addr (1,Hex)	Access	Name	Addr (1,Hex)	Access	Name	Addr (1,Hex)	Access
PRT0DM0	00	RW		40		ASE10CR0	80	RW		C0	
PRT0DM1	01	RW		41			81			C1	
PRT0IC0	02	RW		42			82			C2	
PRT0IC1	03	RW		43			83			C3	
PRT1DM0	04	RW		44		ASE11CR0	84	RW		C4	
PRT1DM1	05	RW		45			85			C5	
PRT1IC0	06	RW		46			86			C6	
PRT1IC1	07	RW		47			87			C7	
	08			48			88			C8	
	09			49			89			C9	
	0A			4A			8A			CA	
	0B			4B			8B			CB	
	0C			4C			8C			CC	
	0D			4D			8D			CD	
	0E			4E			8E			CE	
	0F			4F			8F			CF	
	10			50			90		GDI_O_IN	D0	RW
	11			51			91		GDI_E_IN	D1	RW
	12			52			92		GDI_O_OU	D2	RW
	13			53			93		GDI_E_OU	D3	RW
	14			54			94			D4	
	15			55			95			D5	
	16			56			96			D6	
	17			57			97			D7	
	18			58			98			D8	
	19			59			99			D9	
	1A			5A			9A			DA	
	1B			5B			9B			DB	

Blank fields are Reserved and must not be accessed.

Access is bit specific.

Table 9. Register Map Bank 1 Table: Configuration Space (continued)

Name	Addr (1,Hex)	Access	Name	Addr (1,Hex)	Access	Name	Addr (1,Hex)	Access	Name	Addr (1,Hex)	Access
	1C			5C			9C			DC	
	1D			5D			9D		OSC_GO_EN	DD	RW
	1E			5E			9E		OSC_CR4	DE	RW
	1F			5F			9F		OSC_CR3	DF	RW
DBB00FN	20	RW	CLK_CR0	60	RW		A0		OSC_CR0	E0	RW
DBB00IN	21	RW	CLK_CR1	61	RW		A1		OSC_CR1	E1	RW
DBB00OU	22	RW	ABF_CR0	62	RW		A2		OSC_CR2	E2	RW
	23		AMD_CR0	63	RW		A3		VLT_CR	E3	RW
DBB01FN	24	RW	CMP_GO_EN	64	RW		A4		VLT_CMP	E4	R
DBB01IN	25	RW		65			A5		ADC0_TR	E5	RW
DBB01OU	26	RW	AMD_CR1	66	RW		A6		ADC1_TR	E6	RW
	27		ALT_CR0	67	RW		A7			E7	
DCB02FN	28	RW		68			A8		IMO_TR	E8	W
DCB02IN	29	RW		69			A9		ILO_TR	E9	W
DCB02OU	2A	RW		6A			AA		BDG_TR	EA	RW
	2B		CLK_CR3	6B	RW		AB		ECO_TR	EB	W
DCB03FN	2C	RW	TMP_DR0	6C	RW		AC			EC	
DCB03IN	2D	RW	TMP_DR1	6D	RW		AD			ED	
DCB03OU	2E	RW	TMP_DR2	6E	RW		AE			EE	
	2F		TMP_DR3	6F	RW		AF			EF	
	30			70		RDI0RI	B0	RW		F0	
	31			71		RDI0SYN	B1	RW		F1	
	32		ACE00CR1	72	RW	RDI0IS	B2	RW		F2	
	33		ACE00CR2	73	RW	RDI0LT0	B3	RW		F3	
	34			74		RDI0LT1	B4	RW		F4	
	35			75		RDI0RO0	B5	RW		F5	
	36		ACE01CR1	76	RW	RDI0RO1	B6	RW		F6	
	37		ACE01CR2	77	RW		B7		CPU_F	F7	RL
	38			78			B8			F8	
	39			79			B9			F9	
	3A			7A			BA		FLS_PR1	FA	RW
	3B			7B			BB			FB	
	3C			7C			BC			FC	
	3D			7D			BD			FD	
	3E			7E			BE		CPU_SCR1	FE	#
	3F			7F			BF		CPU_SCR0	FF	#

Blank fields are Reserved and must not be accessed.

Access is bit specific.

Electrical Specifications

This section presents the DC and AC electrical specifications of the CY8C21x23 PSoC device. For up to date electrical specifications, check if you have the latest datasheet by visiting the web at <http://www.cypress.com>.

Specifications are valid for $-40\text{ }^{\circ}\text{C} \leq T_A \leq 85\text{ }^{\circ}\text{C}$ and $T_J \leq 100\text{ }^{\circ}\text{C}$, except where noted.

Refer to Table 24 on page 25 for the electrical specifications on the IMO using SLIMO mode.

Figure 10. Voltage versus CPU Frequency

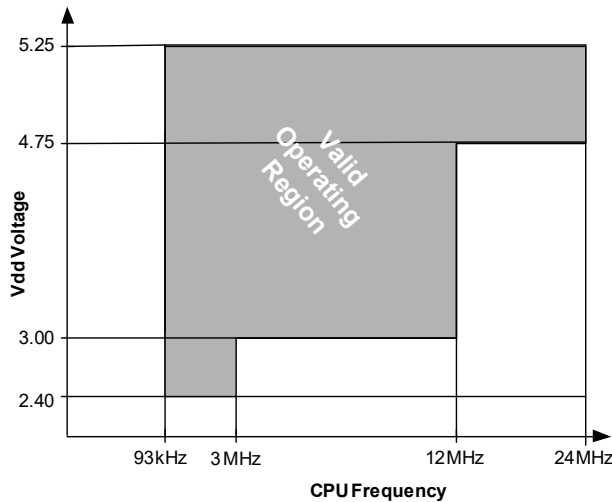
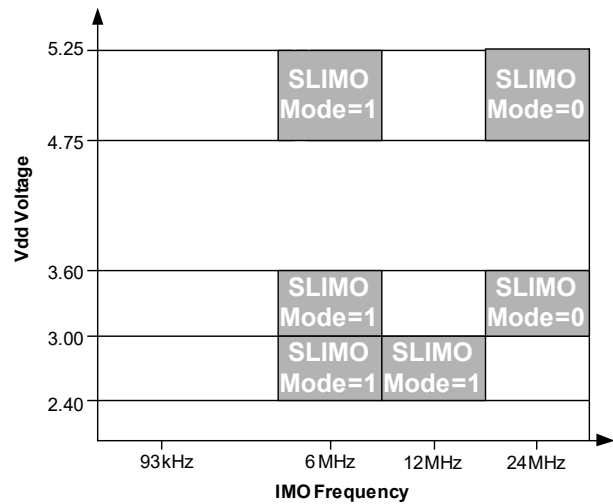

Figure 11. Voltage versus IMO Frequency



Absolute Maximum Ratings

Exceeding maximum ratings may shorten the useful life of the device. User guidelines are not tested.

Table 10. Absolute Maximum Ratings

Symbol	Description	Min	Typ	Max	Units	Notes
T _{STG}	Storage temperature	-55	-	+100	°C	Higher storage temperatures reduce data retention time. Recommended storage temperature is +25 °C ± 25 °C. Extended duration storage temperatures higher than 65 °C degrade reliability.
T _{BAKETEMP}	Bake temperature	-	125	See package label	°C	
t _{BAKETIME}	Bake time	See package label	-	72	Hours	
T _A	Ambient temperature with power applied	-40	-	+85	°C	
V _{DD}	Supply voltage on V _{DD} relative to V _{SS}	-0.5	-	+6.0	V	
V _{IO}	DC input voltage	V _{SS} - 0.5	-	V _{DD} + 0.5	V	
V _{IOZ}	DC voltage applied to tristate	V _{SS} - 0.5	-	V _{DD} + 0.5	V	
I _{MIO}	Maximum current into any port pin	-25	-	+50	mA	
ESD	Electro static discharge voltage	2000	-	-	V	Human body model ESD
LU	Latch-up current	-	-	200	mA	

Operating Temperature

Table 11. Operating Temperature

Symbol	Description	Min	Typ	Max	Units	Notes
T_A	Ambient temperature	-40	-	+85	°C	
T_J	Junction temperature	-40	-	+100	°C	The temperature rise from ambient to junction is package specific. See Table 36 on page 35 . You must limit the power consumption to comply with this requirement.

DC Electrical Characteristics

DC Chip-Level Specifications

[Table 12](#) lists the guaranteed maximum and minimum specifications for the voltage and temperature ranges: 4.75 V to 5.25 V and $-40\text{ °C} \leq T_A \leq 85\text{ °C}$, 3.0 V to 3.6 V and $-40\text{ °C} \leq T_A \leq 85\text{ °C}$, or 2.4 V to 3.0 V and $-40\text{ °C} \leq T_A \leq 85\text{ °C}$, respectively. Typical parameters apply to 5 V, 3.3 V, or 2.7 V at 25 °C and are for design guidance only.

Table 12. DC Chip-Level Specifications

Symbol	Description	Min	Typ	Max	Units	Notes
V_{DD}	Supply voltage	2.40	-	5.25	V	See DC POR and LVD specifications, Table 19 on page 21 .
I_{DD}	Supply current, IMO = 24 MHz	-	3	4	mA	Conditions are $V_{DD} = 5.0\text{ V}$, 25 °C, CPU = 3 MHz, SYSCLOCK doubler disabled. VC1 = 1.5 MHz VC2 = 93.75 kHz VC3 = 0.366 kHz
I_{DD3}	Supply current, IMO = 6 MHz	-	1.2	2	mA	Conditions are $V_{DD} = 3.3\text{ V}$, 25 °C, CPU = 3 MHz, clock doubler disabled. VC1 = 375 kHz VC2 = 23.4 kHz VC3 = 0.091 kHz
I_{DD27}	Supply current, IMO = 6 MHz	-	1.1	1.5	mA	Conditions are $V_{DD} = 2.55\text{ V}$, 25 °C, CPU = 3 MHz, clock doubler disabled. VC1 = 375 kHz VC2 = 23.4 kHz VC3 = 0.091 kHz
I_{SB27}	Sleep (mode) current with POR, LVD, sleep timer, WDT, and internal slow oscillator active. Mid temperature range.	-	2.6	4	μA	$V_{DD} = 2.55\text{ V}$, 0 °C to 40 °C
I_{SB}	Sleep (mode) current with POR, LVD, sleep timer, WDT, and internal slow oscillator active.	-	2.8	5	μA	$V_{DD} = 3.3\text{ V}$, $-40\text{ °C} \leq T_A \leq 85\text{ °C}$
V_{REF}	Reference voltage (bandgap)	1.28	1.30	1.32	V	Trimmed for appropriate V_{DD} . $V_{DD} = 3.0\text{ V to }5.25\text{ V}$
V_{REF27}	Reference voltage (bandgap)	1.16	1.30	1.330	V	Trimmed for appropriate V_{DD} . $V_{DD} = 2.4\text{ V to }3.0\text{ V}$
AGND	Analog ground	$V_{REF} - 0.003$	V_{REF}	$V_{REF} + 0.003$	V	

DC GPIO Specifications

Table 13 lists the guaranteed maximum and minimum specifications for the voltage and temperature ranges: 4.75 V to 5.25 V and $-40\text{ }^{\circ}\text{C} \leq T_A \leq 85\text{ }^{\circ}\text{C}$, 3.0 V to 3.6 V and $-40\text{ }^{\circ}\text{C} \leq T_A \leq 85\text{ }^{\circ}\text{C}$, respectively. Typical parameters apply to 5 V, 3.3 V, or 2.7 V at 25 °C and are for design guidance only.

Table 13. 5-V and 3.3-V DC GPIO Specifications

Symbol	Description	Min	Typ	Max	Units	Notes
R _{PU}	Pull-up resistor	4	5.6	8	kΩ	
R _{PD}	Pull-down resistor	4	5.6	8	kΩ	
V _{OH}	High output level	V _{DD} - 1.0	-	-	V	I _{OH} = 10 mA, V _{DD} = 4.75 to 5.25 V (8 total loads, 4 on even port pins (for example, P0[2], P1[4]), 4 on odd port pins (for example, P0[3], P1[5])). 80 mA maximum combined I _{OH} budget.
V _{OL}	Low output level	-	-	0.75	V	I _{OL} = 25 mA, V _{DD} = 4.75 to 5.25 V (8 total loads, 4 on even port pins (for example, P0[2], P1[4]), 4 on odd port pins (for example, P0[3], P1[5])). 150 mA maximum combined I _{OL} budget.
I _{OH}	High level source current	10	-	-	mA	V _{OH} = V _{DD} - 1.0 V, see the limitations of the total current in the note for V _{OH} .
I _{OL}	Low level sink current	25	-	-	mA	V _{OL} = 0.75 V, see the limitations of the total current in the note for V _{OL} .
V _{IL}	Input low level	-	-	0.8	V	V _{DD} = 3.0 to 5.25
V _{IH}	Input high level	2.1	-	-	V	V _{DD} = 3.0 to 5.25
V _H	Input hysteresis	-	60	-	mV	
I _{IL}	Input leakage (absolute value)	-	1	-	nA	Gross tested to 1 μA
C _{IN}	Capacitive load on pins as input	-	3.5	10	pF	Package and pin dependent. Temp = 25 °C
C _{OUT}	Capacitive load on pins as output	-	3.5	10	pF	Package and pin dependent. Temp = 25 °C

Table 14 lists the guaranteed maximum and minimum specifications for the voltage and temperature ranges: 2.4 V to 3.0 V and $-40\text{ }^{\circ}\text{C} \leq T_A \leq 85\text{ }^{\circ}\text{C}$. Typical parameters apply to 2.7 V at 25 °C and are for design guidance only.

Table 14. 2.7-V DC GPIO Specifications

Symbol	Description	Min	Typ	Max	Units	Notes
R _{PU}	Pull-up resistor	4	5.6	8	kΩ	
R _{PD}	Pull-down resistor	4	5.6	8	kΩ	
V _{OH}	High output level	V _{DD} - 0.4	-	-	V	I _{OH} = 2.5 mA (6.25 Typ), V _{DD} = 2.4 to 3.0 V (16 mA maximum, 50 mA Typ combined I _{OH} budget).
V _{OL}	Low output level	-	-	0.75	V	I _{OL} = 10 mA, V _{DD} = 2.4 to 3.0 V (90 mA maximum combined I _{OL} budget).
I _{OH}	High level source current	2.5	-	-	mA	V _{OH} = V _{DD} - 0.4 V, see the limitations of the total current in the note for V _{OH} .
I _{OL}	Low level sink current	10	-	-	mA	V _{OL} = 0.75 V, see the limitations of the total current in the note for V _{OL} .
V _{IL}	Input low level	-	-	0.75	V	V _{DD} = 2.4 to 3.0
V _{IH}	Input high level	2.0	-	-	V	V _{DD} = 2.4 to 3.0
V _H	Input hysteresis	-	60	-	mV	
I _{IL}	Input leakage (absolute value)	-	1	-	nA	Gross tested to 1 μA
C _{IN}	Capacitive load on pins as input	-	3.5	10	pF	Package and pin dependent. Temp = 25 °C
C _{OUT}	Capacitive load on pins as output	-	3.5	10	pF	Package and pin dependent. Temp = 25 °C

DC Amplifier Specifications

The following tables list the guaranteed maximum and minimum specifications for the voltage and temperature ranges: 4.75 V to 5.25 V and $-40\text{ }^{\circ}\text{C} \leq T_A \leq 85\text{ }^{\circ}\text{C}$, 3.0 V to 3.6 V and $-40\text{ }^{\circ}\text{C} \leq T_A \leq 85\text{ }^{\circ}\text{C}$, or 2.4 V to 3.0 V and $-40\text{ }^{\circ}\text{C} \leq T_A \leq 85\text{ }^{\circ}\text{C}$, respectively. Typical parameters apply to 5 V, 3.3 V, or 2.7 V at 25 °C and are for design guidance only.

Table 15. 5-V DC Amplifier Specifications

Symbol	Description	Min	Typ	Max	Units	Notes
V_{OSOA}	Input offset voltage (absolute value)	–	2.5	15	mV	
TCV_{OSOA}	Average input offset voltage drift	–	10	–	$\mu\text{V}/^{\circ}\text{C}$	
I_{EBOA}	Input leakage current (port 0 analog pins)	–	200	–	pA	Gross tested to 1 μA
C_{INOA}	Input capacitance (port 0 analog pins)	–	4.5	9.5	pF	Package and pin dependent. Temp = 25 °C
V_{CMOA}	Common mode voltage range	0.0	–	$V_{\text{DD}} - 1$	V	
G_{OLOA}	Open loop gain	80	–	–	dB	
I_{SOA}	Amplifier supply current	–	10	30	μA	

Table 16. 3.3-V DC Amplifier Specifications

Symbol	Description	Min	Typ	Max	Units	Notes
V_{OSOA}	Input offset voltage (absolute value)	–	2.5	15	mV	
TCV_{OSOA}	Average input offset voltage drift	–	10	–	$\mu\text{V}/^{\circ}\text{C}$	
I_{EBOA}	Input leakage current (port 0 analog pins)	–	200	–	pA	Gross tested to 1 μA
C_{INOA}	Input capacitance (port 0 analog pins)	–	4.5	9.5	pF	Package and pin dependent. Temp = 25 °C
V_{CMOA}	Common mode voltage range	0	–	$V_{\text{DD}} - 1$	V	
G_{OLOA}	Open loop gain	80	–	–	dB	
I_{SOA}	Amplifier supply current	–	10	30	μA	

Table 17. 2.7V DC Amplifier Specifications

Symbol	Description	Min	Typ	Max	Units	Notes
V_{OSOA}	Input offset voltage (absolute value)	–	2.5	15	mV	
TCV_{OSOA}	Average input offset voltage drift	–	10	–	$\mu\text{V}/^{\circ}\text{C}$	
I_{EBOA}	Input leakage current (port 0 analog pins)	–	200	–	pA	Gross tested to 1 μA
C_{INOA}	Input capacitance (port 0 analog pins)	–	4.5	9.5	pF	Package and pin dependent. Temp = 25 °C
V_{CMOA}	Common mode voltage range	0	–	$V_{\text{DD}} - 1$	V	
G_{OLOA}	Open loop gain	80	–	–	dB	
I_{SOA}	Amplifier supply current	–	10	30	μA	

DC Switch Mode Pump Specifications

Table 18 lists the guaranteed maximum and minimum specifications for the voltage and temperature ranges: 4.75 V to 5.25 V and $-40\text{ }^{\circ}\text{C} \leq T_A \leq 85\text{ }^{\circ}\text{C}$, 3.0 V to 3.6 V and $-40\text{ }^{\circ}\text{C} \leq T_A \leq 85\text{ }^{\circ}\text{C}$, or 2.4 V to 3.0 V and $-40\text{ }^{\circ}\text{C} \leq T_A \leq 85\text{ }^{\circ}\text{C}$, respectively. Typical parameters apply to 5 V, 3.3 V, or 2.7 V at 25 °C and are for design guidance only.

Table 18. DC Switch Mode Pump (SMP) Specifications

Symbol	Description	Min	Typ	Max	Units	Notes
V_{PUMP5V}	5 V output voltage from pump	4.75	5.0	5.25	V	Configuration of footnote. ^[11] Average, neglecting ripple. SMP trip voltage is set to 5.0 V.
V_{PUMP3V}	3.3 V output voltage from pump	3.00	3.25	3.60	V	Configuration of footnote. ^[11] Average, neglecting ripple. SMP trip voltage is set to 3.25 V.
V_{PUMP2V}	2.6 V output voltage from pump	2.45	2.55	2.80	V	Configuration of footnote. ^[11] Average, neglecting ripple. SMP trip voltage is set to 2.55 V.
I_{PUMP}	Available output current $V_{BAT} = 1.8\text{ V}, V_{PUMP} = 5.0\text{ V}$ $V_{BAT} = 1.5\text{ V}, V_{PUMP} = 3.25\text{ V}$ $V_{BAT} = 1.3\text{ V}, V_{PUMP} = 2.55\text{ V}$	5 8 8	– – –	– – –	mA mA mA	Configuration of footnote. ^[11] SMP trip voltage is set to 5.0 V. SMP trip voltage is set to 3.25 V. SMP trip voltage is set to 2.55 V.
V_{BAT5V}	Input voltage range from battery	1.8	–	5.0	V	Configuration of footnote. ^[11] SMP trip voltage is set to 5.0 V.
V_{BAT3V}	Input voltage range from battery	1.0	–	3.3	V	Configuration of footnote. ^[11] SMP trip voltage is set to 3.25 V.
V_{BAT2V}	Input voltage range from battery	1.0	–	2.8	V	Configuration of footnote. ^[11] SMP trip voltage is set to 2.55 V.
$V_{BATSTART}$	Minimum input voltage from battery to start pump	1.2	–	–	V	Configuration of footnote. ^[11] $0\text{ }^{\circ}\text{C} \leq T_A \leq 100$. 1.25 V at $T_A = -40\text{ }^{\circ}\text{C}$.
ΔV_{PUMP_Line}	Line regulation (over V_i range)	–	5	–	% V_O	Configuration of footnote. ^[11] V_O is the “ V_{DD} Value for PUMP Trip” specified by the VM[2:0] setting in the DC POR and LVD Specification, Table 19 on page 21.
ΔV_{PUMP_Load}	Load regulation	–	5	–	% V_O	Configuration of footnote. ^[11] V_O is the “ V_{DD} Value for PUMP Trip” specified by the VM[2:0] setting in the DC POR and LVD Specification, Table 19 on page 21.
ΔV_{PUMP_Ripple}	Output voltage ripple (depends on cap/load)	–	100	–	mVpp	Configuration of footnote. ^[11] Load is 5 mA.
E_3	Efficiency	35	50	–	%	Configuration of footnote. ^[11] Load is 5 mA. SMP trip voltage is set to 3.25 V.
E_2	Efficiency	35	80	–	%	For $I_{load} = 1\text{ mA}$, $V_{PUMP} = 2.55\text{ V}$, $V_{BAT} = 1.3\text{ V}$, 10 μH inductor, 1 μF capacitor, and Schottky diode.
F_{PUMP}	Switching frequency	–	1.3	–	MHz	
DC_{PUMP}	Switching duty cycle	–	50	–	%	

Note

11. $L_1 = 2\text{ mH}$ inductor, $C_1 = 10\text{ mF}$ capacitor, $D_1 =$ Schottky diode. Refer to Figure 12 on page 21.

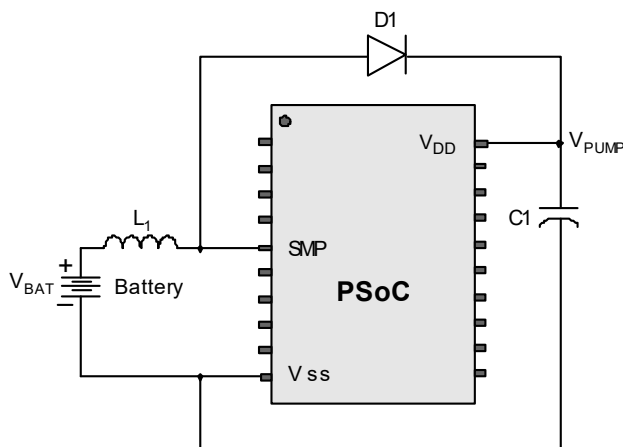
Figure 12. Basic Switch Mode Pump Circuit

DC POR and LVD Specifications

Table 19 lists the guaranteed maximum and minimum specifications for the voltage and temperature ranges: 4.75 V to 5.25 V and $-40\text{ }^{\circ}\text{C} \leq T_A \leq 85\text{ }^{\circ}\text{C}$, 3.0 V to 3.6 V and $-40\text{ }^{\circ}\text{C} \leq T_A \leq 85\text{ }^{\circ}\text{C}$, or 2.4 V to 3.0 V and $-40\text{ }^{\circ}\text{C} \leq T_A \leq 85\text{ }^{\circ}\text{C}$, respectively. Typical parameters apply to 5 V, 3.3 V, or 2.7 V at 25 °C and are for design guidance only.

Table 19. DC POR and LVD Specifications

Symbol	Description	Min	Typ	Max	Units	Notes
V_{PPOR0}	V_{DD} value for PPOR trip PORLEV[1:0] = 00b	–	2.36	2.40	V	V_{DD} must be greater than or equal to 2.5 V during startup, reset from the XRES pin, or reset from watchdog.
V_{PPOR1}	PORLEV[1:0] = 01b	–	2.82	2.95	V	
V_{PPOR2}	PORLEV[1:0] = 10b	–	4.55	4.70	V	
V_{LVD0}	V_{DD} value for LVD trip VM[2:0] = 000b	2.40	2.45	2.51 ^[12]	V	
V_{LVD1}	VM[2:0] = 001b	2.85	2.92	2.99 ^[13]	V	
V_{LVD2}	VM[2:0] = 010b	2.95	3.02	3.09	V	
V_{LVD3}	VM[2:0] = 011b	3.06	3.13	3.20	V	
V_{LVD4}	VM[2:0] = 100b	4.37	4.48	4.55	V	
V_{LVD5}	VM[2:0] = 101b	4.50	4.64	4.75	V	
V_{LVD6}	VM[2:0] = 110b	4.62	4.73	4.83	V	
V_{LVD7}	VM[2:0] = 111b	4.71	4.81	4.95	V	
V_{PUMP0}	V_{DD} value for PUMP trip VM[2:0] = 000b	2.45	2.55	2.62 ^[14]	V	
V_{PUMP1}	VM[2:0] = 001b	2.96	3.02	3.09	V	
V_{PUMP2}	VM[2:0] = 010b	3.03	3.10	3.16	V	
V_{PUMP3}	VM[2:0] = 011b	3.18	3.25	3.32 ^[15]	V	
V_{PUMP4}	VM[2:0] = 100b	4.54	4.64	4.74	V	
V_{PUMP5}	VM[2:0] = 101b	4.62	4.73	4.83	V	
V_{PUMP6}	VM[2:0] = 110b	4.71	4.82	4.92	V	
V_{PUMP7}	VM[2:0] = 111b	4.89	5.00	5.12	V	

Notes

12. Always greater than 50 mV above V_{PPOR} (PORLEV = 00) for falling supply.
13. Always greater than 50 mV above V_{PPOR} (PORLEV = 01) for falling supply.
14. Always greater than 50 mV above V_{LVD0} .
15. Always greater than 50 mV above V_{LVD3} .

DC Programming Specifications

Table 20 lists the guaranteed maximum and minimum specifications for the voltage and temperature ranges: 4.75 V to 5.25 V and $-40\text{ }^{\circ}\text{C} \leq T_A \leq 85\text{ }^{\circ}\text{C}$, 3.0 V to 3.6 V and $-40\text{ }^{\circ}\text{C} \leq T_A \leq 85\text{ }^{\circ}\text{C}$, or 2.4 V to 3.0 V and $-40\text{ }^{\circ}\text{C} \leq T_A \leq 85\text{ }^{\circ}\text{C}$, respectively. Typical parameters apply to 5 V, 3.3 V, or 2.7 V at 25 °C and are for design guidance only.

Table 20. DC Programming Specifications

Symbol	Description	Min	Typ	Max	Units	Notes
V _{DDP}	V _{DD} for programming and erase	4.5	5.0	5.5	V	This specification applies to the functional requirements of external programmer tools
V _{DDL}	Low V _{DD} for verify	2.4	2.5	2.6	V	This specification applies to the functional requirements of external programmer tools
V _{DDHV}	High V _{DD} for verify	5.1	5.2	5.3	V	This specification applies to the functional requirements of external programmer tools
V _{DDIWRITE}	Supply voltage for flash write operations	2.70	–	5.25	V	This specification applies to this device when it is executing internal flash writes
I _{DDP}	Supply current during programming or verify	–	5	25	mA	
V _{ILP}	Input low voltage during programming or verify	–	–	0.8	V	
V _{IHP}	Input high voltage during programming or verify	2.2	–	–	V	
I _{ILP}	Input current when applying V _{ILP} to P1[0] or P1[1] during programming or verify	–	–	0.2	mA	Driving internal pull-down resistor
I _{IHP}	Input current when applying V _{IHP} to P1[0] or P1[1] during programming or verify	–	–	1.5	mA	Driving internal pull-down resistor
V _{OLV}	Output low voltage during programming or verify	–	–	V _{SS} + 0.75	V	
V _{OHV}	Output high voltage during programming or verify	V _{DD} – 1.0	–	V _{DD}	V	
Flash _{ENPB}	Flash endurance (per block)	50,000 ^[16]	–	–	–	Erase/write cycles per block
Flash _{ENT}	Flash endurance (total) ^[17]	1,800,000	–	–	–	Erase/write cycles
Flash _{DR}	Flash data retention	10	–	–	Years	

DC I²C Specifications

Table 20 lists the guaranteed maximum and minimum specifications for the voltage and temperature ranges: 4.75 V to 5.25 V and $-40\text{ }^{\circ}\text{C} \leq T_A \leq 85\text{ }^{\circ}\text{C}$, 3.0 V to 3.6 V and $-40\text{ }^{\circ}\text{C} \leq T_A \leq 85\text{ }^{\circ}\text{C}$, or 2.4 V to 3.0 V and $-40\text{ }^{\circ}\text{C} \leq T_A \leq 85\text{ }^{\circ}\text{C}$, respectively. Typical parameters apply to 5 V, 3.3 V, or 2.7 V at 25 °C and are for design guidance only.

Table 21. DC I²C Specifications^[18]

Symbol	Description	Min	Typ	Max	Units	Notes
V _{ILI2C}	Input low level	–	–	0.3 × V _{DD}	V	2.4 V ≤ V _{DD} ≤ 3.6 V
		–	–	0.25 × V _{DD}	V	4.75 V ≤ V _{DD} ≤ 5.25 V
V _{IHI2C}	Input high level	0.7 × V _{DD}	–	–	V	2.4 V ≤ V _{DD} ≤ 5.25 V

Notes

16. The 50,000 cycle flash endurance per block is guaranteed if the flash is operating within one voltage range. Voltage ranges are 2.4 V to 3.0 V, 3.0 V to 3.6 V, and 4.75 V to 5.25 V.

17. A maximum of 36 × 50,000 block endurance cycles is allowed. This may be balanced between operations on 36 × 1 blocks of 50,000 maximum cycles each, 36 × 2 blocks of 25,000 maximum cycles each, or 36 × 4 blocks of 12,500 maximum cycles each (and so forth to limit the total number of cycles to 36 × 50,000 and that no single block ever sees more than 50,000 cycles). For the full industrial range, you must employ a temperature sensor user module (FlashTemp) and feed the result to the temperature argument before writing. Refer to the application note, [Design Aids — Reading and Writing PSoC[®] Flash — AN2015](#) for more information on Flash APIs.

18. All GPIO meet the DC GPIO V_{IL} and V_{IH} specifications mentioned in section [DC GPIO Specifications on page 18](#). The I²C GPIO pins also meet the mentioned specs.

AC Electrical Characteristics

AC Chip-Level Specifications

Table 22 lists the guaranteed maximum and minimum specifications for the voltage and temperature ranges: 4.75 V to 5.25 V and $-40\text{ }^{\circ}\text{C} \leq T_A \leq 85\text{ }^{\circ}\text{C}$, 3.0 V to 3.6 V and $-40\text{ }^{\circ}\text{C} \leq T_A \leq 85\text{ }^{\circ}\text{C}$, or 2.4 V to 3.0 V and $-40\text{ }^{\circ}\text{C} \leq T_A \leq 85\text{ }^{\circ}\text{C}$, respectively. Typical parameters apply to 5 V, 3.3 V, or 2.7 V at 25 °C and are for design guidance only.

Table 22. 5-V and 3.3-V AC Chip-Level Specifications

Symbol	Description	Min	Typ	Max	Units	Notes
$F_{\text{IMO}24}$ ^[19]	IMO frequency for 24 MHz	22.8	24	25.2 ^[20,21]	MHz	Trimmed for 5 V or 3.3 V operation using factory trim values. Refer to Figure 11 on page 16 . SLIMO mode = 0.
$F_{\text{IMO}6}$	IMO frequency for 6 MHz	5.5	6	6.5 ^[20,21]	MHz	Trimmed for 3.3 V operation using factory trim values. See Figure 11 on page 16 . SLIMO mode = 1.
$F_{\text{CPU}1}$	CPU frequency (5 V nominal)	0.0937	24	24.6 ^[20]	MHz	12 MHz only for SLIMO mode = 0.
$F_{\text{CPU}2}$	CPU frequency (3.3 V nominal)	0.0937	12	12.3 ^[21]	MHz	SLIMO Mode = 0.
$F_{\text{BLK}5}$	Digital PSoC block frequency (5 V nominal)	0	48	49.2 ^[20,22]	MHz	Refer to the section AC Digital Block Specifications on page 26 .
$F_{\text{BLK}33}$	Digital PSoC block frequency (3.3 V nominal)	0	24	24.6 ^[22]	MHz	
F_{32K1}	ILO frequency	15	32	64	kHz	
F_{32K_U}	ILO untrimmed frequency	5	–	100	kHz	After a reset and before the M8C starts to run, the ILO is not trimmed. See the system resets section of the PSoC Technical Reference Manual for details on this timing.
t_{XRST}	External reset pulse width	10	–	–	μs	
DC _{24M}	24 MHz duty cycle	40	50	60	%	
DC _{ILO}	ILO duty cycle	20	50	80	%	
Step _{24M}	24 MHz trim step size	–	50	–	kHz	
$F_{\text{out}48M}$	48 MHz output frequency	46.8	48.0	49.2 ^[20,21]	MHz	Trimmed. Using factory trim values.
F_{MAX}	Maximum frequency of signal on row input or row output.	–	–	12.3	MHz	
$SR_{\text{POWER_UP}}$	Power supply slew rate	–	–	250	V/ms	V_{DD} slew rate during power-up.
t_{POWERUP}	Time from end of POR to CPU executing code	–	16	100	ms	Power-up from 0 V. See the system resets section of the PSoC Technical Reference Manual .
$t_{\text{jit_IMO}}$	24-MHz IMO cycle-to-cycle jitter (RMS) ^[23]	–	200	700	ps	
	24-MHz IMO long term N cycle-to-cycle jitter (RMS) ^[23]	–	300	900	ps	N = 32
	24-MHz IMO period jitter (RMS) ^[23]	–	100	400	ps	

Notes

19. **Errata:** When the device is operated within 0 °C to 70 °C, the frequency tolerance is reduced to $\pm 2.5\%$, but if operated at extreme temperature (below 0 °C or above 70 °C), frequency tolerance deviates from $\pm 2.5\%$ to $\pm 5\%$. For more information, see ["Errata"](#) on page 43.

20. 4.75 V < V_{DD} < 5.25 V.

21. 3.0 V < V_{DD} < 3.6 V. Refer to the application note, [Adjusting PSoC® Trims for 3.3V and 2.7V Operation - AN2012](#) for more information on trimming for operation at 3.3 V.

22. See the individual user module datasheets for information on maximum frequencies for user modules.

23. Refer to the application note, [Understanding Datasheet Jitter Specifications for Cypress Timing Products – AN5054](#) for more information on jitter specifications.

Table 23. 2.7-V AC Chip-Level Specifications

Symbol	Description	Min	Typ	Max	Units	Notes
F _{IMO12}	IMO frequency for 12 MHz	11.5	12	12.7 ^[24,25]	MHz	Trimmed for 2.7 V operation using factory trim values. See Figure 11 on page 16 . SLIMO mode = 1.
F _{IMO6}	IMO frequency for 6 MHz	5.5	6	6.5 ^[24,25]	MHz	Trimmed for 2.7 V operation using factory trim values. See Figure 11 on page 16 . SLIMO mode = 1.
F _{CPU1}	CPU frequency (2.7 V nominal)	0.093	3	3.15 ^[24]	MHz	24 MHz only for SLIMO mode = 0.
F _{BLK27}	Digital PSoC block frequency (2.7 V nominal)	0	12	12.5 ^[24,25]	MHz	Refer to the section AC Digital Block Specifications on page 26 .
F _{32K1}	ILO frequency	8	32	96	kHz	
F _{32K_U}	ILO untrimmed frequency	5	–	100	kHz	After a reset and before the M8C starts to run, the ILO is not trimmed. See the system resets section of the PSoC Technical Reference Manual for details on this timing.
t _{XRST}	External reset pulse width	10	–	–	μs	
DC _{ILO}	ILO duty cycle	20	50	80	%	
F _{MAX}	Maximum frequency of signal on row input or row output	–	–	12.3	MHz	
SR _{POWER_UP}	Power supply slew rate	–	–	250	V/ms	V _{DD} slew rate during power-up.
t _{POWERUP}	Time from end of POR to CPU executing code	–	16	100	ms	Power-up from 0 V. See the system resets section of the PSoC Technical Reference Manual .
t _{jit_IMO}	12-MHz IMO cycle-to-cycle jitter (RMS) ^[26]	–	400	1000	ps	
	12-MHz IMO long term N cycle-to-cycle jitter (RMS) ^[26]	–	600	1300	ps	N = 32
	12-MHz IMO period jitter (RMS) ^[26]	–	100	500	ps	

Notes

24. 2.4 V < V_{DD} < 3.0 V.

25. Refer to the application note, [Adjusting PSoC® Trims for 3.3V and 2.7V Operation - AN2012](#) for more information on maximum frequency for user modules.

26. Refer to the application note, [Understanding Datasheet Jitter Specifications for Cypress Timing Products – AN5054](#) for more information on jitter specifications.

AC General Purpose I/O Specifications

Table 24 lists the guaranteed maximum and minimum specifications for the voltage and temperature ranges: 4.75 V to 5.25 V and $-40\text{ }^{\circ}\text{C} \leq T_A \leq 85\text{ }^{\circ}\text{C}$, 3.0 V to 3.6 V and $-40\text{ }^{\circ}\text{C} \leq T_A \leq 85\text{ }^{\circ}\text{C}$, or 2.4 V to 3.0 V and $-40\text{ }^{\circ}\text{C} \leq T_A \leq 85\text{ }^{\circ}\text{C}$, respectively. Typical parameters apply to 5 V, 3.3 V, or 2.7 V at 25 °C and are for design guidance only.

Table 24. 5-V and 3.3-V AC GPIO Specifications

Symbol	Description	Min	Typ	Max	Units	Notes
F_{GPIO}	GPIO operating frequency	0	–	12	MHz	Normal strong mode
t_{RiseF}	Rise time, normal strong mode, $C_{\text{load}} = 50\text{ pF}$	3	–	18	ns	$V_{\text{DD}} = 4.5\text{ V to }5.25\text{ V}$, 10% to 90%
t_{FallF}	Fall time, normal strong mode, $C_{\text{load}} = 50\text{ pF}$	2	–	18	ns	$V_{\text{DD}} = 4.5\text{ V to }5.25\text{ V}$, 10% to 90%
t_{RiseS}	Rise time, slow strong mode, $C_{\text{load}} = 50\text{ pF}$	10	27	–	ns	$V_{\text{DD}} = 3\text{ V to }5.25\text{ V}$, 10% to 90%
t_{FallS}	Fall time, slow strong mode, $C_{\text{load}} = 50\text{ pF}$	10	22	–	ns	$V_{\text{DD}} = 3\text{ V to }5.25\text{ V}$, 10% to 90%

Table 25. 2.7-V AC GPIO Specifications

Symbol	Description	Min	Typ	Max	Units	Notes
F_{GPIO}	GPIO operating frequency	0	–	3	MHz	Normal strong mode
t_{RiseF}	Rise time, normal strong mode, $C_{\text{load}} = 50\text{ pF}$	6	–	50	ns	$V_{\text{DD}} = 2.4\text{ V to }3.0\text{ V}$, 10% to 90%
t_{FallF}	Fall time, normal strong mode, $C_{\text{load}} = 50\text{ pF}$	6	–	50	ns	$V_{\text{DD}} = 2.4\text{ V to }3.0\text{ V}$, 10% to 90%
t_{RiseS}	Rise time, slow strong mode, $C_{\text{load}} = 50\text{ pF}$	18	40	120	ns	$V_{\text{DD}} = 2.4\text{ V to }3.0\text{ V}$, 10% to 90%
t_{FallS}	Fall time, slow strong mode, $C_{\text{load}} = 50\text{ pF}$	18	40	120	ns	$V_{\text{DD}} = 2.4\text{ V to }3.0\text{ V}$, 10% to 90%

Figure 13. GPIO Timing Diagram

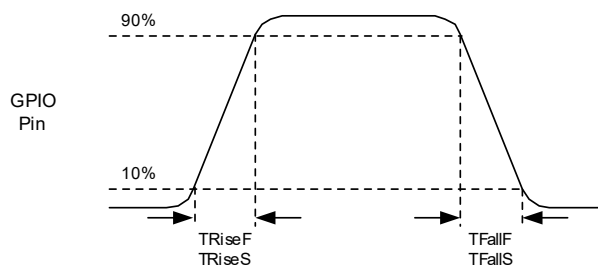

AC Amplifier Specifications

The following tables list the guaranteed maximum and minimum specifications for the voltage and temperature ranges: 4.75 V to 5.25 V and $-40\text{ }^{\circ}\text{C} \leq T_A \leq 85\text{ }^{\circ}\text{C}$, 3.0 V to 3.6 V and $-40\text{ }^{\circ}\text{C} \leq T_A \leq 85\text{ }^{\circ}\text{C}$, or 2.4 V to 3.0 V and $-40\text{ }^{\circ}\text{C} \leq T_A \leq 85\text{ }^{\circ}\text{C}$, respectively. Typical parameters apply to 5 V, 3.3 V, or 2.7 V at 25 °C and are for design guidance only.

Settling times, slew rates, and gain bandwidth are based on the analog continuous time PSoC block.

Table 26. 5-V and 3.3-V AC Amplifier Specifications

Symbol	Description	Min	Typ	Max	Units
t_{COMP1}	Comparator mode response time, 50 mVpp signal centered on Ref	–	–	100	ns
t_{COMP2}	Comparator mode response time, 2.5 V input, 0.5 V overdrive	–	–	300	ns

Table 27. 2.7-V AC Amplifier Specifications

Symbol	Description	Min	Typ	Max	Units
t_{COMP1}	Comparator mode response time, 50 mVpp signal centered on Ref	–	–	600	ns
t_{COMP2}	Comparator mode response time, 1.5 V input, 0.5 V overdrive	–	–	300	ns

AC Digital Block Specifications

Table 28 lists the guaranteed maximum and minimum specifications for the voltage and temperature ranges: 4.75 V to 5.25 V and $-40\text{ }^{\circ}\text{C} \leq T_A \leq 85\text{ }^{\circ}\text{C}$, 3.0 V to 3.6 V and $-40\text{ }^{\circ}\text{C} \leq T_A \leq 85\text{ }^{\circ}\text{C}$, or 2.4 V to 3.0 V and $-40\text{ }^{\circ}\text{C} \leq T_A \leq 85\text{ }^{\circ}\text{C}$, respectively. Typical parameters apply to 5 V, 3.3 V, or 2.7 V at 25 °C and are for design guidance only.

Table 28. 5-V and 3.3-V AC Digital Block Specifications

Function	Description	Min	Typ	Max	Unit	Notes
All functions	Block input clock frequency					
	$V_{DD} \geq 4.75\text{ V}$	–	–	50.4	MHz	
	$V_{DD} < 4.75\text{ V}$	–	–	25.2	MHz	
Timer	Input clock frequency					
	No capture, $V_{DD} \geq 4.75\text{ V}$	–	–	50.4	MHz	
	No capture, $V_{DD} < 4.75\text{ V}$	–	–	25.2	MHz	
	With capture	–	–	25.2	MHz	
	Capture pulse width	50 ^[27]	–	–	ns	
Counter	Input clock frequency					
	No enable input, $V_{DD} \geq 4.75\text{ V}$	–	–	50.4	MHz	
	No enable input, $V_{DD} < 4.75\text{ V}$	–	–	25.2	MHz	
	With enable input	–	–	25.2	MHz	
	Enable input pulse width	50 ^[27]	–	–	ns	
Dead Band	Kill pulse width					
	Asynchronous restart mode	20	–	–	ns	
	Synchronous restart mode	50 ^[27]	–	–	ns	
	Disable mode	50 ^[27]	–	–	ns	
	Input clock frequency					
	$V_{DD} \geq 4.75\text{ V}$	–	–	50.4	MHz	
	$V_{DD} < 4.75\text{ V}$	–	–	25.2	MHz	
CRCPRS (PRS Mode)	Input clock frequency					
	$V_{DD} \geq 4.75\text{ V}$	–	–	50.4	MHz	
	$V_{DD} < 4.75\text{ V}$	–	–	25.2	MHz	
CRCPRS (CRC Mode)	Input clock frequency	–	–	25.2	MHz	
SPIM	Input clock frequency	–	–	8.2	MHz	The SPI serial clock (SCLK) frequency is equal to the input clock frequency divided by 2.
SPIS	Input clock (SCLK) frequency	–	–	4.1	MHz	The input clock is the SPI SCLK in SPIS mode.
	Width of SS_negated between transmissions	50 ^[27]	–	–	ns	
Transmitter	Input clock frequency					The baud rate is equal to the input clock frequency divided by 8.
	$V_{DD} \geq 4.75\text{ V}$, 2 stop bits	–	–	50.4	MHz	
	$V_{DD} \geq 4.75\text{ V}$, 1 stop bit	–	–	25.2	MHz	
	$V_{DD} < 4.75\text{ V}$	–	–	25.2	MHz	
Receiver	Input clock frequency					The baud rate is equal to the input clock frequency divided by 8.
	$V_{DD} \geq 4.75\text{ V}$, 2 stop bits	–	–	50.4	MHz	
	$V_{DD} \geq 4.75\text{ V}$, 1 stop bit	–	–	25.2	MHz	
	$V_{DD} < 4.75\text{ V}$	–	–	25.2	MHz	

Note

27. 50 ns minimum input pulse width is based on the input synchronizers running at 24 MHz (42 ns nominal period).

Table 29. 2.7-V AC Digital Block Specifications

Function	Description	Min	Typ	Max	Units	Notes
All functions	Block input clock frequency	–	–	12.7	MHz	2.4 V < V _{DD} < 3.0 V.
Timer	Capture pulse width	100 ^[28]	–	–	ns	
	Input clock frequency, with or without capture	–	–	12.7	MHz	
Counter	Enable input pulse width	100	–	–	ns	
	Input clock frequency, no enable input	–	–	12.7	MHz	
	Input clock frequency, enable input	–	–	12.7	MHz	
Dead band	Kill pulse width:					
	Asynchronous restart mode	20	–	–	ns	
	Synchronous restart mode	100	–	–	ns	
	Disable mode	100	–	–	ns	
	Input clock frequency	–	–	12.7	MHz	
CRCPRS (PRS mode)	Input clock frequency	–	–	12.7	MHz	
CRCPRS (CRC mode)	Input clock frequency	–	–	12.7	MHz	
SPIM	Input clock frequency	–	–	6.35	MHz	The SPI serial clock (SCLK) frequency is equal to the input clock frequency divided by 2.
SPIS	Input clock (SCLK) frequency	–	–	4.1	MHz	
	Width of SS_ Negated between transmissions	100	–	–	ns	
Transmitter	Input clock frequency	–	–	12.7	MHz	The baud rate is equal to the input clock frequency divided by 8.
Receiver	Input clock frequency	–	–	12.7	MHz	The baud rate is equal to the input clock frequency divided by 8.

Note

28. 100 ns minimum input pulse width is based on the input synchronizers running at 12 MHz (84 ns nominal period).

AC External Clock Specifications

The following tables list the guaranteed maximum and minimum specifications for the voltage and temperature ranges: 4.75 V to 5.25 V and $-40\text{ }^{\circ}\text{C} \leq T_A \leq 85\text{ }^{\circ}\text{C}$, or 3.0 V to 3.6 V and $-40\text{ }^{\circ}\text{C} \leq T_A \leq 85\text{ }^{\circ}\text{C}$, respectively. Typical parameters apply to 5 V, 3.3 V, or 2.7 V at 25 °C and are for design guidance only.

Table 30. 5-V AC External Clock Specifications

Symbol	Description	Min	Typ	Max	Units	Notes
F _{OSCEXT}	Frequency	0.093	–	24.6	MHz	
–	High period	20.6	–	5300	ns	
–	Low period	20.6	–	–	ns	
–	Power-up IMO to switch	150	–	–	μs	

Table 31. 3.3-V AC External Clock Specifications

Symbol	Description	Min	Typ	Max	Units	Notes
F _{OSCEXT}	Frequency with CPU clock divide by 1	0.093	–	12.3	MHz	Maximum CPU frequency is 12 MHz at 3.3 V. With the CPU clock divider set to 1, the external clock must adhere to the maximum frequency and duty cycle requirements.
F _{OSCEXT}	Frequency with CPU clock divide by 2 or greater	0.186	–	24.6	MHz	If the frequency of the external clock is greater than 12 MHz, the CPU clock divider must be set to 2 or greater. In this case, the CPU clock divider ensures that the fifty percent duty cycle requirement is met.
–	High period with CPU clock divide by 1	41.7	–	5300	ns	
–	Low period with CPU clock divide by 1	41.7	–	–	ns	
–	Power-up IMO to switch	150	–	–	μs	

Table 32. 2.7-V AC External Clock Specifications

Symbol	Description	Min	Typ	Max	Units	Notes
F _{OSCEXT}	Frequency with CPU clock divide by 1	0.093	–	6.06	MHz	Maximum CPU frequency is 3 MHz at 2.7 V. With the CPU clock divider set to 1, the external clock must adhere to the maximum frequency and duty cycle requirements.
F _{OSCEXT}	Frequency with CPU clock divide by 2 or greater	0.186	–	12.12	MHz	If the frequency of the external clock is greater than 3 MHz, the CPU clock divider must be set to 2 or greater. In this case, the CPU clock divider ensures that the fifty percent duty cycle requirement is met.
–	High period with CPU clock divide by 1	83.4	–	5300	ns	
–	Low period with CPU clock divide by 1	83.4	–	–	ns	
–	Power-up IMO to switch	150	–	–	μs	

AC Programming Specifications

Table 33 lists the guaranteed maximum and minimum specifications for the voltage and temperature ranges: 4.75 V to 5.25 V and $-40\text{ }^{\circ}\text{C} \leq T_A \leq 85\text{ }^{\circ}\text{C}$, or 3.0 V to 3.6 V and $-40\text{ }^{\circ}\text{C} \leq T_A \leq 85\text{ }^{\circ}\text{C}$, respectively. Typical parameters apply to 5 V, 3.3 V, or 2.7 V at 25 °C and are for design guidance only.

Table 33. AC Programming Specifications

Symbol	Description	Min	Typ	Max	Units	Notes
t_{RSCLK}	Rise time of SCLK	1	–	20	ns	
t_{FSCLK}	Fall time of SCLK	1	–	20	ns	
t_{SSCLK}	Data set up time to falling edge of SCLK	40	–	–	ns	
t_{HSCLK}	Data hold time from falling edge of SCLK	40	–	–	ns	
F_{SCLK}	Frequency of SCLK	0	–	8	MHz	
t_{ERASEB}	Flash erase time (block)	–	10	–	ms	
t_{WRITE}	Flash block write time	–	80	–	ms	
t_{DSCLK3}	Data out delay from falling edge of SCLK	–	–	50	ns	$3.0 \leq V_{DD} \leq 3.6$.
t_{DSCLK2}	Data out delay from falling edge of SCLK	–	–	70	ns	$2.4 \leq V_{DD} \leq 3.0$.
$t_{ERASEALL}$	Flash erase time (bulk)	–	20	–	ms	Erase all blocks and protection fields at once.
$t_{PROGRAM_HOT}$	Flash block erase + flash block write time	–	–	180 ^[30]	ms	$0\text{ }^{\circ}\text{C} \leq T_j \leq 100\text{ }^{\circ}\text{C}$.
$t_{PROGRAM_COLD}$	Flash block erase + flash block write time	–	–	360 ^[30]	ms	$-40\text{ }^{\circ}\text{C} \leq T_j \leq 0\text{ }^{\circ}\text{C}$.

AC I²C Specifications

Table 34 lists the guaranteed maximum and minimum specifications for the voltage and temperature ranges: 4.75 V to 5.25 V and $-40\text{ }^{\circ}\text{C} \leq T_A \leq 85\text{ }^{\circ}\text{C}$, 3.0 V to 3.6 V and $-40\text{ }^{\circ}\text{C} \leq T_A \leq 85\text{ }^{\circ}\text{C}$, or 2.4 V to 3.0 V and $-40\text{ }^{\circ}\text{C} \leq T_A \leq 85\text{ }^{\circ}\text{C}$, respectively. Typical parameters apply to 5 V, 3.3 V, or 2.7 V at 25 °C and are for design guidance only.

Table 34. AC Characteristics of the I²C SDA and SCL Pins for $V_{CC} \geq 3.0\text{ V}$

Symbol	Description	Standard Mode		Fast Mode		Units
		Min	Max	Min	Max	
F_{SCL2C}	SCL clock frequency	0	100	0	400	kHz
$t_{HDSTA2C}$	Hold time (repeated) START condition. After this period, the first clock pulse is generated.	4.0	–	0.6	–	μs
t_{LOW2C}	Low period of the SCL clock	4.7	–	1.3	–	μs
t_{HIGH2C}	High period of the SCL clock	4.0	–	0.6	–	μs
$t_{SUSTA2C}$	Setup time for a repeated START condition	4.7	–	0.6	–	μs
$t_{HDDAT2C}$	Data hold time	0	–	0	–	μs
$t_{SUDAT2C}$	Data setup time	250	–	100 ^[29]	–	ns
$t_{SUSTOI2C}$	Setup time for STOP condition	4.0	–	0.6	–	μs
t_{BUFI2C}	Bus free time between a STOP and START condition	4.7	–	1.3	–	μs
t_{SPI2C}	Pulse width of spikes are suppressed by the input filter	–	–	0	50	ns

Notes

29. A fast-mode I²C-bus device can be used in a standard-mode I²C-bus system, but the requirement $t_{SUDAT} \geq 250\text{ ns}$ must then be met. This automatically becomes the case if the device does not stretch the LOW period of the SCL signal. If such device does stretch the LOW period of the SCL signal, it must output the next data bit to the SDA line $t_{max} + t_{SUDAT} = 1000 + 250 = 1250\text{ ns}$ (according to the standard-mode I²C-bus specification) before the SCL line is released.
30. For the full industrial range, you must employ a temperature sensor user module (FlashTemp) and feed the result to the temperature argument before writing. Refer to the application note, [Design Aids — Reading and Writing PSoC[®] Flash – AN2015](#) for more information on Flash APIs.

Table 35. 2.7-V AC Characteristics of the I²C SDA and SCL Pins (Fast Mode Not Supported)

Symbol	Description	Standard Mode		Fast Mode		Units
		Min	Max	Min	Max	
F _{SCL I2C}	SCL clock frequency	0	100	–	–	kHz
t _{HDSTAI2C}	Hold time (repeated) START Condition. After this period, the first clock pulse is generated.	4.0	–	–	–	μs
t _{LOWI2C}	Low period of the SCL clock	4.7	–	–	–	μs
t _{HIGHI2C}	High period of the SCL clock	4.0	–	–	–	μs
t _{SUSTAI2C}	Setup time for a repeated START condition	4.7	–	–	–	μs
t _{HDDATI2C}	Data hold time	0	–	–	–	μs
t _{SUDATI2C}	Data setup time	250	–	–	–	ns
t _{SUSTOI2C}	Setup time for STOP condition	4.0	–	–	–	μs
t _{BUF I2C}	Bus free time between a STOP and START condition	4.7	–	–	–	μs
t _{SPI2C}	Pulse width of spikes are suppressed by the input filter.	–	–	–	–	ns

Figure 14. Definition for Timing for Fast/Standard Mode on the I²C Bus

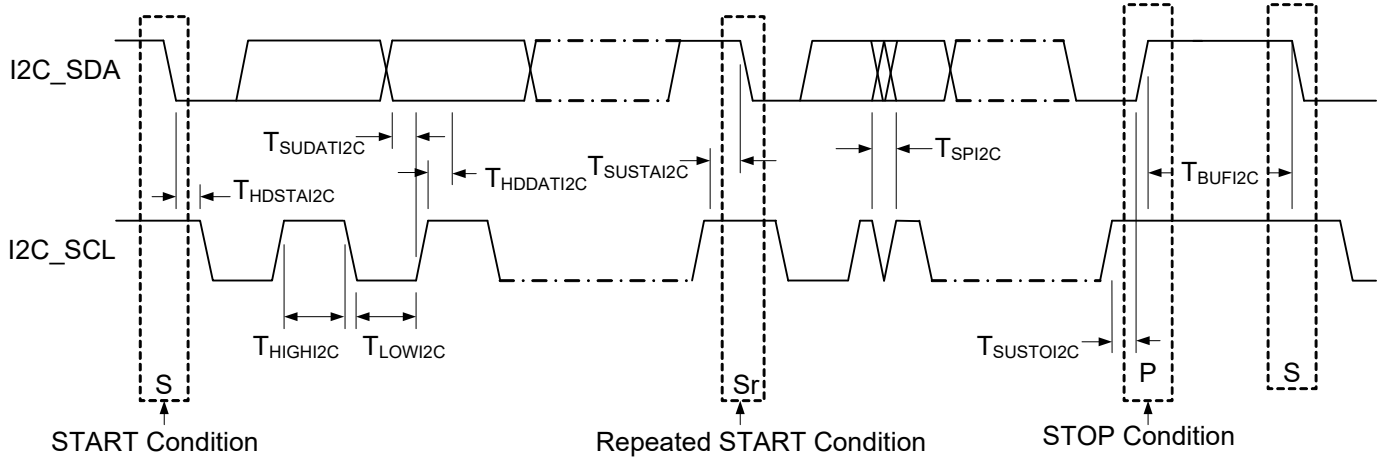

Packaging Information

This section illustrates the packaging specifications for the CY8C21x23 PSoC device, along with the thermal impedances for each package and minimum solder reflow peak temperature.

Important Note Emulation tools may require a larger area on the target PCB than the chip's footprint. For a detailed description of the emulation tools' dimensions, refer to the emulator pod drawings at <http://www.cypress.com>.

Packaging Dimensions

Figure 15. 8-pin SOIC (150 Mils) S0815/SZ815/SW815 Package Outline, 51-85066

8 Lead (150 Mil) SOIC – S08

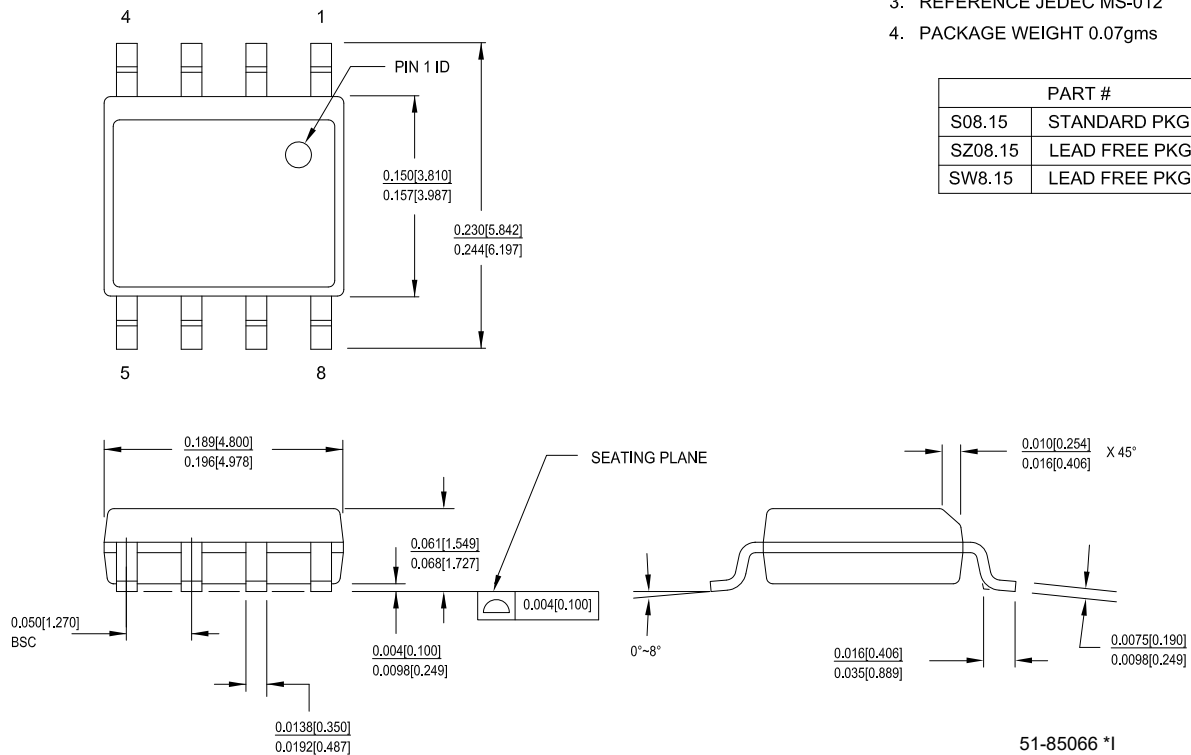

1. DIMENSIONS IN INCHES[MM] MIN. MAX.
2. PIN 1 ID IS OPTIONAL, ROUND ON SINGLE LEADFRAME RECTANGULAR ON MATRIX LEADFRAME
3. REFERENCE JEDEC MS-012
4. PACKAGE WEIGHT 0.07gms

Figure 16. 16-Pin (150-Mil) SOIC

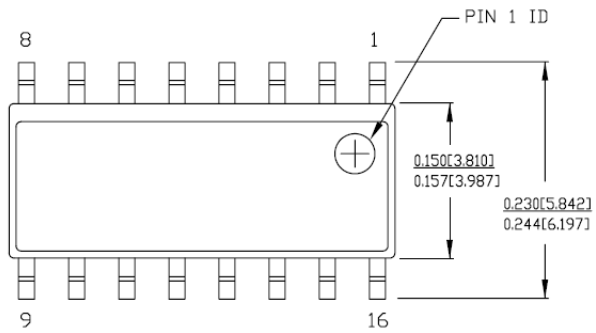

NOTE:

1. DIMENSIONS IN INCHES[MM] MAX.
2. REFERENCE JEDEC MS-012
3. PACKAGE WEIGHT : refer to PMDD spec. 001-04308

PART #	
S16.15	STANDARD PKG.
SZ16.15	LEAD FREE PKG.

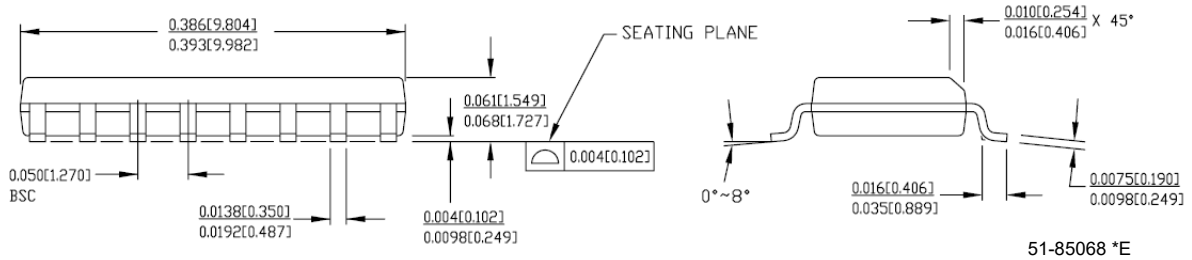
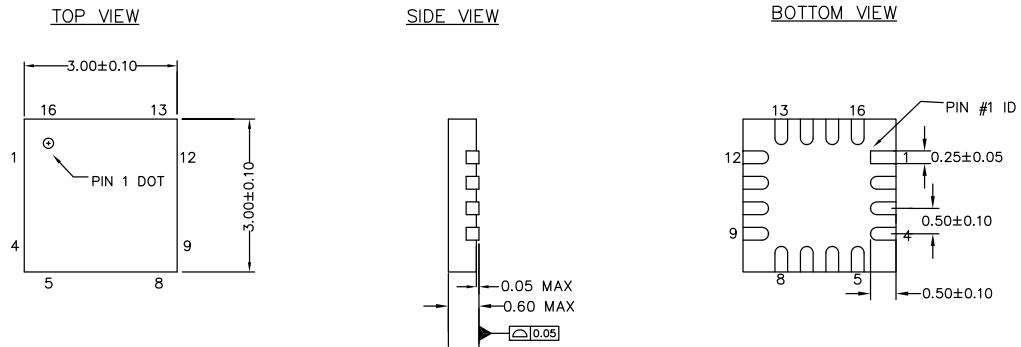

Figure 17. 16-Pin QFN with no E-Pad



NOTES

1. REFERENCE JEDEC # MO-220
2. ALL DIMENSIONS ARE IN MILLIMETERS

001-09116 *J

Figure 18. 20-pin SSOP (210 Mils) O20.21 Package Outline, 51-85077

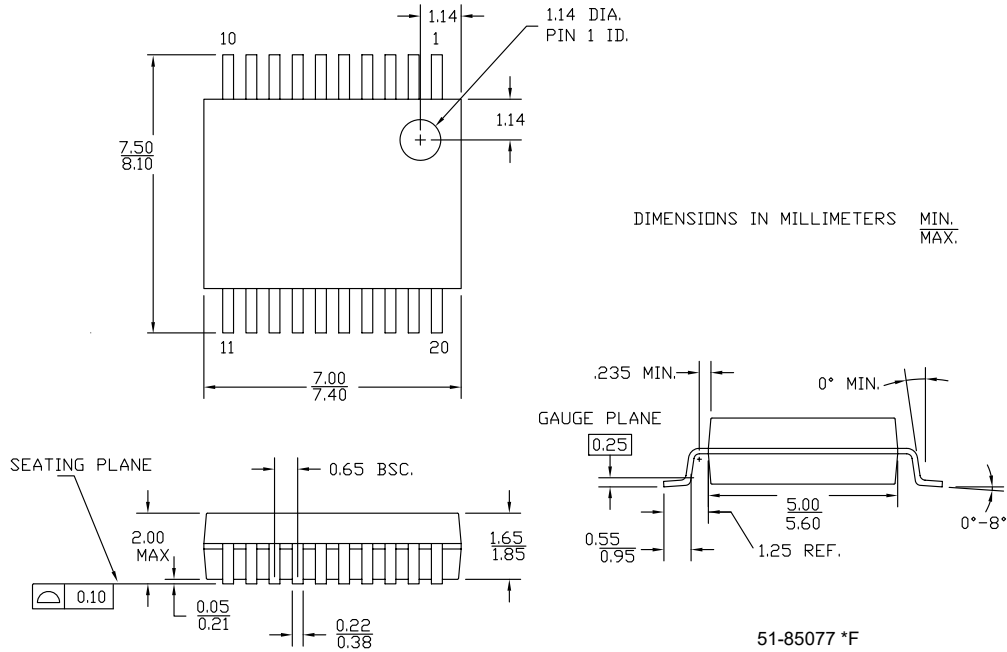
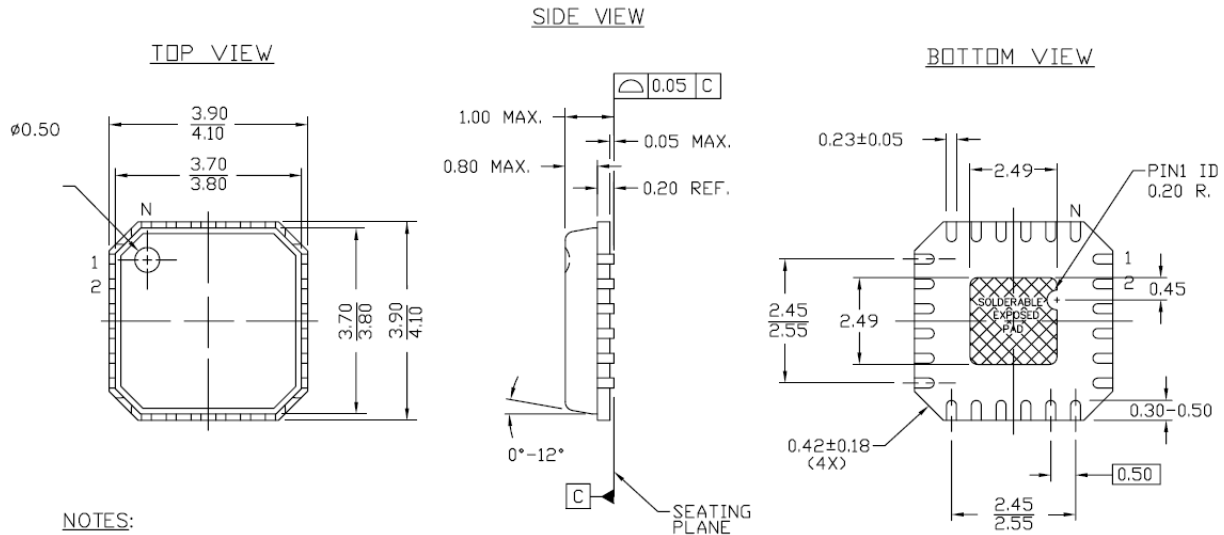



Figure 19. 24-Pin (4 × 4) QFN (Punched)



NOTES:

1.  HATCH IS SOLDERABLE EXPOSED METAL.
2. REFERENCE JEDEC#: MO-220
3. PACKAGE WEIGHT: REFER TO PMDD SPEC.
4. ALL DIMENSIONS ARE IN MM [MIN/MAX]
5. PACKAGE CODE

PART #	DESCRIPTION
LF24A	STANDARD
LY24A	LEAD FREE

Figure 20. 24-Pin (4 × 4) QFN (Sawn)

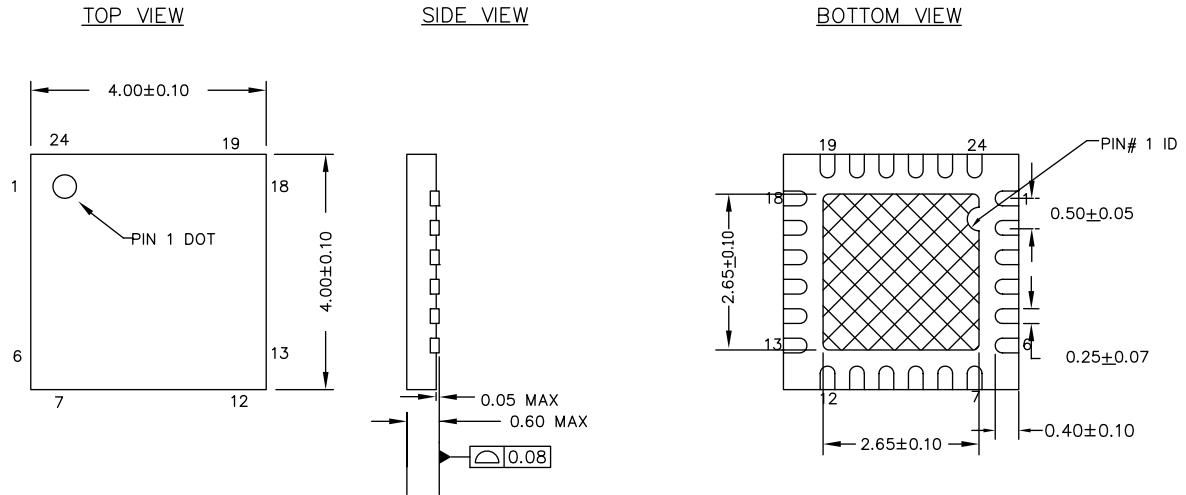

NOTES :

1.  HATCH IS SOLDERABLE EXPOSED METAL.
2. REFERENCE JEDEC # MO-248
3. PACKAGE WEIGHT : 29 ± 3 mg
4. ALL DIMENSIONS ARE IN MILLIMETERS

001-13937 *F

Important Note For information on the preferred dimensions for mounting QFN packages, refer the application note, Application Notes for Surface Mount Assembly of Amkor's MicroLeadFrame (MLF) Packages available at <http://www.amkor.com>.

Note that pinned vias for thermal conduction are not required for the low power 24, 32, and 48-pin QFN PSoC devices.

Thermal Impedances

Table 36. Thermal Impedances per Package

Package	Typical θ_{JA} ^[31]
8-pin SOIC	186 °C/W
16-pin SOIC	125 °C/W
16-pin QFN	46 °C/W
20-pin SSOP	117 °C/W
24-pin QFN ^[32]	40 °C/W

Solder Reflow Specifications

Table 37 shows the solder reflow temperature limits that must not be exceeded.

Table 37. Solder Reflow Specifications

Package	Maximum Peak Temperature (T_C)	Maximum Time above $T_C - 5$ °C
8-pin SOIC	260 °C	30 seconds
16-pin SOIC	260 °C	30 seconds
16-pin QFN	260 °C	30 seconds
20-pin SSOP	260 °C	30 seconds
24-pin QFN	260 °C	30 seconds

Notes

31. $T_J = T_A + \text{POWER} \times \theta_{JA}$

32. To achieve the thermal impedance specified for the QFN package, refer to “Application Notes for Surface Mount Assembly of Amkor’s MicroLeadFrame (MLF) Packages” available at <http://www.amkor.com>.

33. Higher temperatures may be required based on the solder melting point. Typical temperatures for solder are 220+/-5 °C with Sn-Pb or 245+/-5 °C with Sn-Ag-Cu paste. Refer to the solder manufacturer specifications.

Ordering Information

The following table lists the CY8C21x23 PSoC device's key package features and ordering codes.

Table 38. CY8C21x23 PSoC Device Key Features and Ordering Information

Package	Ordering Code	Flash (Bytes)	RAM (Bytes)	Switch Mode Pump	Temperature Range	Digital PSoC Blocks	Analog Blocks	Digital I/O Pins	Analog Inputs	Analog Outputs	XRES Pin
8-Pin (150-Mil) SOIC	CY8C21123-24SXI	4 K	256	No	-40 °C to +85 °C	4	4	6	4	0	No
8-Pin (150-Mil) SOIC (Tape and Reel)	CY8C21123-24SXIT	4 K	256	No	-40 °C to +85 °C	4	4	6	4	0	No
16-Pin (150-Mil) SOIC	CY8C21223-24SXI	4 K	256	Yes	-40 °C to +85 °C	4	4	12	8	0	No
16-Pin (150-Mil) SOIC (Tape and Reel)	CY8C21223-24SXIT	4 K	256	Yes	-40 °C to +85 °C	4	4	12	8	0	No
16-Pin (3 × 3) QFN with no E-Pad	CY8C21223-24LGXI	4 K	256	No	-40 °C to +85 °C	4	4	12	8	0	Yes
20-Pin (210-Mil) SSOP	CY8C21323-24PVXI	4 K	256	No	-40 °C to +85 °C	4	4	16	8	0	Yes
20-Pin (210-Mil) SSOP (Tape and Reel)	CY8C21323-24PVXIT	4 K	256	No	-40 °C to +85 °C	4	4	16	8	0	Yes
24-Pin (4 × 4) QFN (Punched)	CY8C21323-24LFXI	4 K	256	Yes	-40 °C to +85 °C	4	4	16	8	0	Yes
24-Pin (4 × 4) QFN (Punched) (Tape and Reel)	CY8C21323-24LFXIT	4 K	256	Yes	-40 °C to +85 °C	4	4	16	8	0	Yes
24-Pin (4 × 4) QFN (Sawn)	CY8C21323-24LQXI	4 K	256	Yes	-40 °C to +85 °C	4	4	16	8	0	Yes
24-Pin (4 × 4) QFN (Sawn) (Tape and Reel)	CY8C21323-24LQXIT	4 K	256	Yes	-40 °C to +85 °C	4	4	16	8	0	Yes

Note For Die sales information, contact a local Cypress sales office or Field Applications Engineer (FAE).

Ordering Code Definitions

CY 8 C 21 xxx-24xx

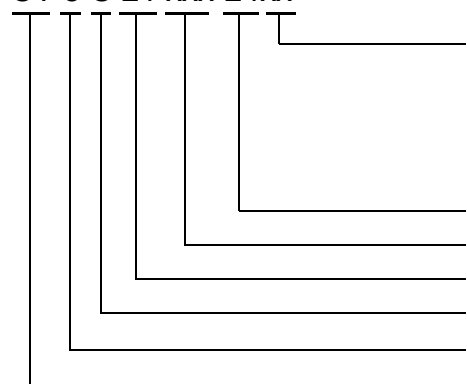

Package Type:
 SX = SOIC Pb-Free
 PVX = SSOP Pb-Free
 LGX = QFN (sawn, 3 × 3 mm), Pb-Free
 LFX = QFN (punched, 4 × 4 mm), Pb-Free
 LQX = QFN (sawn, 4 × 4 mm), Pb-Free

Speed: 24 MHz

Part Number

Family Code

Technology Code: C = CMOS

Marketing Code: 8 = Cypress PSoC

Company ID: CY = Cypress

Thermal Rating:
 C = Commercial
 I = Industrial
 E = Extended

Acronyms

Acronyms Used

Table 39 lists the acronyms that are used in this document.

Table 39. Acronyms Used in this Datasheet

Acronym	Description	Acronym	Description
AC	alternating current	PCB	printed circuit board
ADC	analog-to-digital converter	PGA	programmable gain amplifier
API	application programming interface	POR	power on reset
CMOS	complementary metal oxide semiconductor	PPOR	precision power on reset
CPU	central processing unit	PRS	pseudo-random sequence
CRC	cyclic redundancy check	PSoC®	Programmable System-on-Chip
CT	continuous time	PWM	pulse width modulator
DAC	digital-to-analog converter	QFN	quad flat no leads
DC	direct current	SC	switched capacitor
EEPROM	electrically erasable programmable read-only memory	SLIMO	slow IMO
GPIO	general purpose I/O	SMP	switch mode pump
ICE	in-circuit emulator	SOIC	small-outline integrated circuit
IDE	integrated development environment	SPI™	serial peripheral interface
ILO	internal low speed oscillator	SRAM	static random access memory
IMO	internal main oscillator	SROM	supervisory read only memory
I/O	input/output	SSOP	shrink small-outline package
IrDA	infrared data association	UART	universal asynchronous receiver / transmitter
ISSP	in-system serial programming	USB	universal serial bus
LVD	low voltage detect	WDT	watchdog timer
MCU	microcontroller unit	XRES	external reset
MIPS	million instructions per second		

Reference Documents

CY8CPLC20, CY8CLED16P01, CY8C29x66, CY8C27x43, CY8C24x94, CY8C24x23, CY8C24x23A, CY8C22x13, CY8C21x34, CY8C21x23, CY7C64215, CY7C603xx, CY8CNP1xx, and CYWUSB6953 PSoC® Programmable System-on-Chip Technical Reference Manual (TRM) (001-14463)

Design Aids – Reading and Writing PSoC® Flash – AN2015 (001-40459)

Adjusting PSoC® Trims for 3.3V and 2.7V Operation - AN2012 (001-17397)

Understanding Datasheet Jitter Specifications for Cypress Timing Products – AN5054 (001-14503)

Application Notes for Surface Mount Assembly of Amkor's MicroLeadFrame (MLF) Packages – available at <http://www.amkor.com>.

Document Conventions

Units of Measure

Table 40 lists the units of measures.

Table 40. Units of Measure

Symbol	Unit of Measure	Symbol	Unit of Measure
dB	decibels	mH	millihenry
°C	degree Celsius	μH	microhenry
μF	microfarad	μs	microsecond
pF	picofarad	ms	millisecond
kHz	kilohertz	ns	nanosecond
MHz	megahertz	ps	picosecond
rt-Hz	root hertz	μV	microvolt
kΩ	kilohm	mV	millivolt
Ω	ohm	mVpp	millivolts peak-to-peak
μA	microampere	V	volt
mA	milliampere	W	watt
nA	nanoampere	mm	millimeter
pA	pikoampere	%	percent

Numeric Conventions

Hexadecimal numbers are represented with all letters in uppercase with an appended lowercase 'h' (for example, '14h' or '3Ah'). Hexadecimal numbers may also be represented by a '0x' prefix, the C coding convention. Binary numbers have an appended lowercase 'b' (for example, '01010100b' or '01000011b'). Numbers not indicated by an 'h' or 'b' are decimals.

Glossary

active high	<ol style="list-style-type: none"> 1. A logic signal having its asserted state as the logic 1 state. 2. A logic signal having the logic 1 state as the higher voltage of the two states.
analog blocks	The basic programmable opamp circuits. These are SC (switched capacitor) and CT (continuous time) blocks. These blocks can be interconnected to provide ADCs, DACs, multi-pole filters, gain stages, and much more.
analog-to-digital (ADC)	A device that changes an analog signal to a digital signal of corresponding magnitude. Typically, an ADC converts a voltage to a digital number. The digital-to-analog (DAC) converter performs the reverse operation.
Application programming interface (API)	A series of software routines that comprise an interface between a computer application and lower level services and functions (for example, user modules and libraries). APIs serve as building blocks for programmers that create software applications.
asynchronous	A signal whose data is acknowledged or acted upon immediately, irrespective of any clock signal.
bandgap reference	A stable voltage reference design that matches the positive temperature coefficient of VT with the negative temperature coefficient of VBE, to produce a zero temperature coefficient (ideally) reference.
bandwidth	<ol style="list-style-type: none"> 1. The frequency range of a message or information processing system measured in hertz. 2. The width of the spectral region over which an amplifier (or absorber) has substantial gain (or loss); it is sometimes represented more specifically as, for example, full width at half maximum.

Glossary (continued)

bias	<ol style="list-style-type: none">1. A systematic deviation of a value from a reference value.2. The amount by which the average of a set of values departs from a reference value.3. The electrical, mechanical, magnetic, or other force (field) applied to a device to establish a reference level to operate the device.
block	<ol style="list-style-type: none">1. A functional unit that performs a single function, such as an oscillator.2. A functional unit that may be configured to perform one of several functions, such as a digital PSoC block or an analog PSoC block.
buffer	<ol style="list-style-type: none">1. A storage area for data that is used to compensate for a speed difference, when transferring data from one device to another. Usually refers to an area reserved for IO operations, into which data is read, or from which data is written.2. A portion of memory set aside to store data, often before it is sent to an external device or as it is received from an external device.3. An amplifier used to lower the output impedance of a system.
bus	<ol style="list-style-type: none">1. A named connection of nets. Bundling nets together in a bus makes it easier to route nets with similar routing patterns.2. A set of signals performing a common function and carrying similar data. Typically represented using vector notation; for example, address[7:0].3. One or more conductors that serve as a common connection for a group of related devices.
clock	The device that generates a periodic signal with a fixed frequency and duty cycle. A clock is sometimes used to synchronize different logic blocks.
comparator	An electronic circuit that produces an output voltage or current whenever two input levels simultaneously satisfy predetermined amplitude requirements.
compiler	A program that translates a high level language, such as C, into machine language.
configuration space	In PSoC devices, the register space accessed when the XIO bit, in the CPU_F register, is set to '1'.
crystal oscillator	An oscillator in which the frequency is controlled by a piezoelectric crystal. Typically a piezoelectric crystal is less sensitive to ambient temperature than other circuit components.
cyclic redundancy check (CRC)	A calculation used to detect errors in data communications, typically performed using a linear feedback shift register. Similar calculations may be used for a variety of other purposes such as data compression.
data bus	A bi-directional set of signals used by a computer to convey information from a memory location to the central processing unit and vice versa. More generally, a set of signals used to convey data between digital functions.
debugger	A hardware and software system that allows you to analyze the operation of the system under development. A debugger usually allows the developer to step through the firmware one step at a time, set break points, and analyze memory.
dead band	A period of time when neither of two or more signals are in their active state or in transition.
digital blocks	The 8-bit logic blocks that can act as a counter, timer, serial receiver, serial transmitter, CRC generator, pseudo-random number generator, or SPI.
digital-to-analog (DAC)	A device that changes a digital signal to an analog signal of corresponding magnitude. The analog-to-digital (ADC) converter performs the reverse operation.

Glossary (continued)

duty cycle	The relationship of a clock period high time to its low time, expressed as a percent.
emulator	Duplicates (provides an emulation of) the functions of one system with a different system, so that the second system appears to behave like the first system.
External Reset (XRES)	An active high signal that is driven into the PSoC device. It causes all operation of the CPU and blocks to stop and return to a pre-defined state.
Flash	An electrically programmable and erasable, non-volatile technology that provides you the programmability and data storage of EPROMs, plus in-system erasability. Non-volatile means that the data is retained when power is OFF.
Flash block	The smallest amount of Flash ROM space that may be programmed at one time and the smallest amount of Flash space that may be protected. A Flash block holds 64 bytes.
frequency	The number of cycles or events per unit of time, for a periodic function.
gain	The ratio of output current, voltage, or power to input current, voltage, or power, respectively. Gain is usually expressed in dB.
I ² C	A two-wire serial computer bus by Philips Semiconductors (now NXP Semiconductors). I2C is an Inter-Integrated Circuit. It is used to connect low-speed peripherals in an embedded system. The original system was created in the early 1980s as a battery control interface, but it was later used as a simple internal bus system for building control electronics. I2C uses only two bi-directional pins, clock and data, both running at +5 V and pulled high with resistors. The bus operates at 100 kbits/second in standard mode and 400 kbits/second in fast mode.
ICE	The in-circuit emulator that allows you to test the project in a hardware environment, while viewing the debugging device activity in a software environment (PSoC Designer).
input/output (I/O)	A device that introduces data into or extracts data from a system.
interrupt	A suspension of a process, such as the execution of a computer program, caused by an event external to that process, and performed in such a way that the process can be resumed.
interrupt service routine (ISR)	A block of code that normal code execution is diverted to when the M8C receives a hardware interrupt. Many interrupt sources may each exist with its own priority and individual ISR code block. Each ISR code block ends with the RETI instruction, returning the device to the point in the program where it left normal program execution.
jitter	<ol style="list-style-type: none">1. A misplacement of the timing of a transition from its ideal position. A typical form of corruption that occurs on serial data streams.2. The abrupt and unwanted variations of one or more signal characteristics, such as the interval between successive pulses, the amplitude of successive cycles, or the frequency or phase of successive cycles.
low-voltage detect (LVD)	A circuit that senses V_{DD} and provides an interrupt to the system when V_{DD} falls lower than a selected threshold.
M8C	An 8-bit Harvard-architecture microprocessor. The microprocessor coordinates all activity inside a PSoC by interfacing to the Flash, SRAM, and register space.
master device	A device that controls the timing for data exchanges between two devices. Or when devices are cascaded in width, the master device is the one that controls the timing for data exchanges between the cascaded devices and an external interface. The controlled device is called the slave device .

Glossary (continued)

microcontroller	An integrated circuit chip that is designed primarily for control systems and products. In addition to a CPU, a microcontroller typically includes memory, timing circuits, and IO circuitry. The reason for this is to permit the realization of a controller with a minimal quantity of chips, thus achieving maximal possible miniaturization. This in turn, reduces the volume and the cost of the controller. The microcontroller is normally not used for general-purpose computation as is a microprocessor.
mixed-signal	The reference to a circuit containing both analog and digital techniques and components.
modulator	A device that imposes a signal on a carrier.
noise	<ol style="list-style-type: none">1. A disturbance that affects a signal and that may distort the information carried by the signal.2. The random variations of one or more characteristics of any entity such as voltage, current, or data.
oscillator	A circuit that may be crystal controlled and is used to generate a clock frequency.
parity	A technique for testing transmitting data. Typically, a binary digit is added to the data to make the sum of all the digits of the binary data either always even (even parity) or always odd (odd parity).
Phase-locked loop (PLL)	An electronic circuit that controls an oscillator so that it maintains a constant phase angle relative to a reference signal.
pinouts	The pin number assignment: the relation between the logical inputs and outputs of the PSoC device and their physical counterparts in the printed circuit board (PCB) package. Pinouts involve pin numbers as a link between schematic and PCB design (both being computer generated files) and may also involve pin names.
port	A group of pins, usually eight.
Power on reset (POR)	A circuit that forces the PSoC device to reset when the voltage is lower than a pre-set level. This is one type of hardware reset.
PSoC®	Cypress Semiconductor's PSoC® is a registered trademark and Programmable System-on-Chip™ is a trademark of Cypress.
PSoC Designer™	The software for Cypress' Programmable System-on-Chip technology.
pulse width modulator (PWM)	An output in the form of duty cycle which varies as a function of the applied measurand.
RAM	An acronym for random access memory. A data-storage device from which data can be read out and new data can be written in.
register	A storage device with a specific capacity, such as a bit or byte.
reset	A means of bringing a system back to a know state. See hardware reset and software reset.
ROM	An acronym for read only memory. A data-storage device from which data can be read out, but new data cannot be written in.
serial	<ol style="list-style-type: none">1. Pertaining to a process in which all events occur one after the other.2. Pertaining to the sequential or consecutive occurrence of two or more related activities in a single device or channel.
settling time	The time it takes for an output signal or value to stabilize after the input has changed from one value to another.

Glossary (continued)

shift register	A memory storage device that sequentially shifts a word either left or right to output a stream of serial data.
slave device	A device that allows another device to control the timing for data exchanges between two devices. Or when devices are cascaded in width, the slave device is the one that allows another device to control the timing of data exchanges between the cascaded devices and an external interface. The controlling device is called the master device.
SRAM	An acronym for static random access memory. A memory device where you can store and retrieve data at a high rate of speed. The term static is used because, after a value is loaded into an SRAM cell, it remains unchanged until it is explicitly altered or until power is removed from the device.
SROM	An acronym for supervisory read only memory. The SROM holds code that is used to boot the device, calibrate circuitry, and perform Flash operations. The functions of the SROM may be accessed in normal user code, operating from Flash.
stop bit	A signal following a character or block that prepares the receiving device to receive the next character or block.
synchronous	<ol style="list-style-type: none">1. A signal whose data is not acknowledged or acted upon until the next active edge of a clock signal.2. A system whose operation is synchronized by a clock signal.
tri-state	A function whose output can adopt three states: 0, 1, and Z (high-impedance). The function does not drive any value in the Z state and, in many respects, may be considered to be disconnected from the rest of the circuit, allowing another output to drive the same net.
UART	A UART or universal asynchronous receiver-transmitter translates between parallel bits of data and serial bits.
user modules	Pre-build, pre-tested hardware/firmware peripheral functions that take care of managing and configuring the lower level Analog and Digital PSoC Blocks. User Modules also provide high level API (Application Programming Interface) for the peripheral function.
user space	The bank 0 space of the register map. The registers in this bank are more likely to be modified during normal program execution and not just during initialization. Registers in bank 1 are most likely to be modified only during the initialization phase of the program.
V _{DD}	A name for a power net meaning "voltage drain." The most positive power supply signal. Usually 5 V or 3.3 V.
V _{SS}	A name for a power net meaning "voltage source." The most negative power supply signal.
watchdog timer	A timer that must be serviced periodically. If it is not serviced, the CPU resets after a specified period of time.

Errata

This section describes the errata for the CY8C21x23 PSoC[®] programmable system-on-chip family. Details include errata trigger conditions, scope of impact, available workarounds, and silicon revision applicability.

Contact your local Cypress Sales Representative if you have questions.

Part Numbers Affected

Part Number	Ordering Information
CY8C21123	CY8C21123-24SXI
	CY8C21123-24SXIT
	CY8C21223-24SXI
	CY8C21223-24SXIT
	CY8C21323-24PVXI
	CY8C21323-24PVXIT
	CY8C21323-24LFXI
	CY8C21323-24LFXIT
	CY8C21323-24LQXI
	CY8C21323-24LQXIT

CY8C21123 Qualification Status

Product Status: Production

CY8C21123 Errata Summary

The following table defines the errata applicability to available CY8C21123 family devices. An "X" indicates that the errata pertains to the selected device.

Note Errata items, in the table below, are hyperlinked. Click on any item entry to jump to its description.

Items	Part Number	Silicon Revision	Fix Status
[1.] Internal Main Oscillator (IMO) Tolerance Deviation at Temperature Extremes	CY8C21123	A	No silicon fix is planned. Workaround is required.

1. Internal Main Oscillator (IMO) Tolerance Deviation at Temperature Extremes

■ Problem Definition

Asynchronous Digital Communications Interfaces may fail framing beyond 0 to 70 °C. This problem does not affect end-product usage between 0 and 70 °C.

■ Parameters Affected

The IMO frequency tolerance. The worst case deviation when operated below 0 °C and above +70 °C and within the upper and lower datasheet temperature range is ±5%.

■ Trigger Condition(S)

The asynchronous Rx/Tx clock source IMO frequency tolerance may deviate beyond the data sheet limit of ±2.5% when operated beyond the temperature range of 0 to +70 °C.

■ Scope of Impact

This problem may affect UART, IrDA, and FSK implementations.

■ Workaround

Implement a quartz crystal stabilized clock source on at least one end of the asynchronous digital communications interface.

■ Fix Status

No silicon fix is planned. The workaround mentioned above should be used.

Document History Page

Document Title: CY8C21123/CY8C21223/CY8C21323, PSoc [®] Programmable System-on-Chip™ Document Number: 38-12022				
Revision	ECN	Orig. of Change	Submission Date	Description of Change
**	133248	NWJ	See ECN	New silicon and document (Revision **).
*A	208900	NWJ	See ECN	Add new part, new package and update all ordering codes to Pb-free.
*B	212081	NWJ	See ECN	Expand and prepare Preliminary version.
*C	227321	CMS Team	See ECN	Update specs., data, format.
*D	235973	SFV	See ECN	Updated Overview and Electrical Spec. chapters, along with 24-pin pinout. Added CMP_GO_EN register (1,64h) to mapping table.
*E	290991	HMT	See ECN	Update datasheet standards per SFV memo. Fix device table. Add part numbers to pinouts and fine tune. Change 20-pin SSOP to CY8C21323. Add Reflow Temp. table. Update diagrams and specs.
*F	301636	HMT	See ECN	DC Chip-Level Specification changes. Update links to new CY.com Portal.
*G	324073	HMT	See ECN	Obtained clearer 16 SOIC package. Update Thermal Impedances and Solder Reflow tables. Re-add pinout ISSP notation. Fix ADC type-o. Fix TMP register names. Update Electrical Specifications. Add CY logo. Update CY copyright. Make datasheet Final.
*H	2588457	KET / HMI / AESA	10/22/2008	New package information on page 9. Converted datasheet to new template. Added 16-Pin OFN package diagram.
*I	2618175	OGNE / PYRS	12/09/2008	Added Note in Ordering Information Section. Changed title from PSoc Mixed-Signal Array to PSoc Programmable System-on-Chip. Updated 'Development Tools' and 'Designing with PSoc Designer' sections on pages 5 and 6
*J	2682782	MAXK / AESA	04/03/2009	Corrected 16 COL pinout.
*K	2699713	MAXK	04/29/2009	Minor ECN to correct paragraph style of 16 COL Pinout. No change in content.
*L	2762497	JVY	09/11/2009	Updated DC GPIO, AC Chip-Level, and AC Programming Specifications as follows: Modified F _{IMO6} and T _{WRITE} specifications. Replaced T _{RAMP} time) specification with SR _{POWER_UP} (slew rate) specification. Added note [11] to Flash Endurance specification. Added I _{OH} , I _{OL} , DC _{ILO} , F _{32K_U} , T _{POWERUP} , T _{ERASEALL} , T _{PROGRAM_HOT} , and T _{PROGRAM_COLD} specifications..
*M	2792630	TTO	10/26/2009	Updated ordering information for CY8C21223-24LGXI to indicate availability of XRES pin.
*N	2901653	NJF	03/30/2010	Changed 16-pin COL to 16-pin QFN in the datasheet. Added Contents . Updated links in Sales, Solutions, and Legal Information Updated Cypress website links. Added T _{BAKETEMP} and T _{BAKETIME} parameters in Absolute Maximum Ratings Updated 5-V and 3.3-V AC Chip-Level Specifications Updated Notes in Packaging Information and package diagrams. Updated Ordering Code Definitions
*O	2928895	YJI	05/06/2010	No technical updates. Included with EROS spec.

Document History Page (continued)

Document Title: CY8C21123/CY8C21223/CY8C21323, PSoC [®] Programmable System-on-Chip™				
Document Number: 38-12022				
Revision	ECN	Orig. of Change	Submission Date	Description of Change
*P	3044869	NJF	10/01/2010	Added PSoC Device Characteristics table. Added DC I ² C Specifications table. Added F _{32K U} max limit. Added T _{jitter} IMO specification, removed existing jitter specifications. Updated Units of Measure, Acronyms, Glossary, and References sections. Updated solder reflow specifications. No specific changes were made to AC Digital Block Specifications table and I ² C Timing Diagram. They were updated for clearer understanding. Updated Figure 13 since the labelling for y-axis was incorrect. Template and styles update.
*Q	3263669	YJI	05/23/2011	Updated 16-pin SOIC and 20-pin SSOP package diagrams. Updated Development Tool Selection and Designing with PSoC Designer sections.
*R	3383787	GIR	09/26/2011	The text "Pin must be left floating" is included under Description of NC pin in Table 6 on page 11 . Updated Table 37 on page 35 for improved clarity.
*S	3558729	RJVB	03/22/2012	Updated 16-pin SOIC package.
*T	3598261	LURE / XZNG	04/24/2012	Changed the PWM description string from "8- to 32-bit" to "8- and 16-bit".
*U	3649990	BVI / YLIU	06/19/2012	Updated description of NC pin as "No Connection. Pin must be left floating"
*V	3873870	UVS	01/18/2013	Updated Packaging Information : spec 51-85068 – Changed revision from *D to *E. spec 001-09116 – Changed revision from *F to *G. spec 51-85203 – Changed revision from *C to *D.
*W	3993321	UVS	05/07/2013	Added Errata .
*X	4067216	UVS	07/18/2013	Added Errata footnotes (Note 19). Updated Features : Replaced 2.5% with 5% under "Precision, programmable clocking". Updated Electrical Specifications : Updated AC Electrical Characteristics : Updated AC Chip-Level Specifications : Added Note 19 and referred the same note in F _{IMO24} parameter. Updated minimum and maximum values of F _{IMO24} parameter. Updated AC Digital Block Specifications : Replaced all instances of maximum value "49.2" with "50.4" and "24.6" with "25.2" in Table 28 . Updated Packaging Information : spec 51-85066 – Changed revision from *E to *F. spec 001-09116 – Changed revision from *G to *H. Updated to new template.
*Y	4479648	RJVB	08/20/2014	Updated Errata : Updated CY8C21123 Errata Summary : Updated details in "Fix Status" column in the table. Updated details in "Fix Status" bulleted point below the table.

Document History Page (continued)

Document Title: CY8C21123/CY8C21223/CY8C21323, PSoC® Programmable System-on-Chip™ Document Number: 38-12022				
Revision	ECN	Orig. of Change	Submission Date	Description of Change
*Z	4623500	DIMA	01/14/2015	Updated Pin Information : Updated 20-Pin Part Pinout : Updated Table 5 : Added Note 6 and referred the same note in description of pin 5 and pin 10. Updated 24-Pin Part Pinout : Updated Table 6 : Added Note 9 and referred the same note in description of pin 3, pin 9 and pin 21. Updated Packaging Information : spec 51-85066 – Changed revision from *F to *G. spec 51-85077 – Changed revision from *E to *F. Completing Sunset Review.
AA	5090662	ARVI	01/18/2016	Updated Ordering Information , Ordering Code Definitions , and Errata . Updated figure title in Figure 19 . Updated Table 38 . Updated Figure 15 (spec 51-85066 *G to *H) in Packaging Information . Added Figure 20 (spec 001-13937 *F) in Packaging Information .
AB	5773393	AESATMP9	06/14/2017	Updated logo and copyright.
AC	5974328	ARVI	11/22/2017	Updated Figure 15 (spec 51-85066 *H to *I) in Packaging Information .

Sales, Solutions, and Legal Information

Worldwide Sales and Design Support

Cypress maintains a worldwide network of offices, solution centers, manufacturer's representatives, and distributors. To find the office closest to you, visit us at [Cypress Locations](#).

Products

ARM® Cortex® Microcontrollers	cypress.com/arm
Automotive	cypress.com/automotive
Clocks & Buffers	cypress.com/clocks
Interface	cypress.com/interface
Internet of Things	cypress.com/iot
Memory	cypress.com/memory
Microcontrollers	cypress.com/mcu
PSoC	cypress.com/psoc
Power Management ICs	cypress.com/pmic
Touch Sensing	cypress.com/touch
USB Controllers	cypress.com/usb
Wireless Connectivity	cypress.com/wireless

PSoC® Solutions

[PSoC 1](#) | [PSoC 3](#) | [PSoC 4](#) | [PSoC 5LP](#) | [PSoC 6](#)

Cypress Developer Community

[Forums](#) | [WICED IOT Forums](#) | [Projects](#) | [Video](#) | [Blogs](#) | [Training](#) | [Components](#)

Technical Support

cypress.com/support



© Cypress Semiconductor Corporation, 2004-2017. This document is the property of Cypress Semiconductor Corporation and its subsidiaries, including Spansion LLC ("Cypress"). This document, including any software or firmware included or referenced in this document ("Software"), is owned by Cypress under the intellectual property laws and treaties of the United States and other countries worldwide. Cypress reserves all rights under such laws and treaties and does not, except as specifically stated in this paragraph, grant any license under its patents, copyrights, trademarks, or other intellectual property rights. If the Software is not accompanied by a license agreement and you do not otherwise have a written agreement with Cypress governing the use of the Software, then Cypress hereby grants you a personal, non-exclusive, nontransferable license (without the right to sublicense) (1) under its copyright rights in the Software (a) for Software provided in source code form, to modify and reproduce the Software solely for use with Cypress hardware products, only internally within your organization, and (b) to distribute the Software in binary code form externally to end users (either directly or indirectly through resellers and distributors), solely for use on Cypress hardware product units, and (2) under those claims of Cypress's patents that are infringed by the Software (as provided by Cypress, unmodified) to make, use, distribute, and import the Software solely for use with Cypress hardware products. Any other use, reproduction, modification, translation, or compilation of the Software is prohibited.

TO THE EXTENT PERMITTED BY APPLICABLE LAW, CYPRESS MAKES NO WARRANTY OF ANY KIND, EXPRESS OR IMPLIED, WITH REGARD TO THIS DOCUMENT OR ANY SOFTWARE OR ACCOMPANYING HARDWARE, INCLUDING, BUT NOT LIMITED TO, THE IMPLIED WARRANTIES OF MERCHANTABILITY AND FITNESS FOR A PARTICULAR PURPOSE. To the extent permitted by applicable law, Cypress reserves the right to make changes to this document without further notice. Cypress does not assume any liability arising out of the application or use of any product or circuit described in this document. Any information provided in this document, including any sample design information or programming code, is provided only for reference purposes. It is the responsibility of the user of this document to properly design, program, and test the functionality and safety of any application made of this information and any resulting product. Cypress products are not designed, intended, or authorized for use as critical components in systems designed or intended for the operation of weapons, weapons systems, nuclear installations, life-support devices or systems, other medical devices or systems (including resuscitation equipment and surgical implants), pollution control or hazardous substances management, or other uses where the failure of the device or system could cause personal injury, death, or property damage ("Unintended Uses"). A critical component is any component of a device or system whose failure to perform can be reasonably expected to cause the failure of the device or system, or to affect its safety or effectiveness. Cypress is not liable, in whole or in part, and you shall and hereby do release Cypress from any claim, damage, or other liability arising from or related to all Unintended Uses of Cypress products. You shall indemnify and hold Cypress harmless from and against all claims, costs, damages, and other liabilities, including claims for personal injury or death, arising from or related to any Unintended Uses of Cypress products.

Cypress, the Cypress logo, Spansion, the Spansion logo, and combinations thereof, WICED, PSoC, CapSense, EZ-USB, F-RAM, and Traveo are trademarks or registered trademarks of Cypress in the United States and other countries. For a more complete list of Cypress trademarks, visit cypress.com. Other names and brands may be claimed as property of their respective owners.

Looking for pricing, stock, or lifecycle information?

Click below to explore more details on WIN SOURCE:

-  [View CY8C21223-24LGXIT on WIN SOURCE](#)
-  [Cypress Semiconductor Corp Information](#)

Optimize Your Supply Chain with WIN SOURCE Solutions

-  Global Sourcing Solution
-  Obsolete Management
-  Cost Control Management
-  Shortage Management
-  Alternative Solution
-  Excess Inventory Management