



# THE DATASHEET OF SN74AC533NSRE4



# SN54AC533, SN74AC533 OCTAL TRANSPARENT D-TYPE LATCHES WITH 3-STATE OUTPUTS

SCAS555C – NOVEMBER 1995 – REVISED OCTOBER 2003

- 2-V to 6-V  $V_{CC}$  Operation
- Inputs Accept Voltages to 6 V
- Max  $t_{pd}$  of 10.5 ns at 5 V
- 3-State Inverting Outputs Drive Bus Lines Directly
- Full Parallel Access for Loading

## description/ordering information

The 'AC533 devices are octal transparent D-type latches with 3-state outputs. When the latch-enable (LE) input is high, the  $\bar{Q}$  outputs follow the complements of the data (D) inputs. When LE is taken low, the  $\bar{Q}$  outputs are latched at the inverse logic levels set up at the D inputs.

A buffered output-enable ( $\overline{OE}$ ) input can be used to place the eight outputs in either a normal logic state (high or low logic levels) or the high-impedance state. In the high-impedance state, the outputs neither load nor drive the bus lines significantly. The high-impedance state and increased drive provide the capability to drive bus lines without need for interface or pullup components.

$\overline{OE}$  does not affect the internal operations of the latches. Old data can be retained or new data can be entered while the outputs are in the high-impedance state.

To ensure the high-impedance state during power up or power down,  $\overline{OE}$  should be tied to  $V_{CC}$  through a pullup resistor; the minimum value of the resistor is determined by the current-sinking capability of the driver.

SN54AC533 . . . J OR W PACKAGE  
SN74AC533 . . . DB, DW, N, NS, OR PW PACKAGE  
(TOP VIEW)

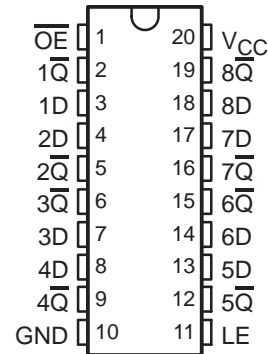

SN54AC533 . . . FK PACKAGE  
(TOP VIEW)

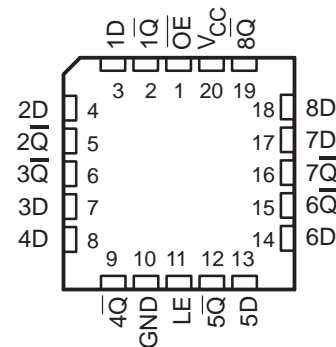

## ORDERING INFORMATION

$T_A$	PACKAGE†		ORDERABLE PART NUMBER	TOP-SIDE MARKING
-40°C to 85°C	PDIP – N	Tube	SN74AC533N	SN74AC533N
	SOIC – DW	Tube	SN74AC533DW	AC533
		Tape and reel	SN74AC533DWR	
	SOP – NS	Tape and reel	SN74AC533NSR	AC533
	SSOP – DB	Tape and reel	SN74AC533DBR	AC533
-55°C to 125°C	TSSOP – PW	Tube	SN74AC533PW	AC533
		Tape and reel	SN74AC533PWR	
-55°C to 125°C	CDIP – J	Tube	SNJ54AC533J	SNJ54AC533J
	CFP – W	Tube	SNJ54AC533W	SNJ54AC533W
	LCCC – FK	Tube	SNJ54AC533FK	SNJ54AC533FK

† Package drawings, standard packing quantities, thermal data, symbolization, and PCB design guidelines are available at [www.ti.com/sc/package](http://www.ti.com/sc/package).



Please be aware that an important notice concerning availability, standard warranty, and use in critical applications of Texas Instruments semiconductor products and disclaimers thereto appears at the end of this data sheet.

UNLESS OTHERWISE NOTED this document contains PRODUCTION DATA information current as of publication date. Products conform to specifications per the terms of Texas Instruments standard warranty. Production processing does not necessarily include testing of all parameters.

 **TEXAS  
INSTRUMENTS**

POST OFFICE BOX 655303 • DALLAS, TEXAS 75265

Copyright © 2003, Texas Instruments Incorporated

# SN54AC533, SN74AC533 OCTAL TRANSPARENT D-TYPE LATCHES WITH 3-STATE OUTPUTS

SCAS555C – NOVEMBER 1995 – REVISED OCTOBER 2003

FUNCTION TABLE  
(each latch)

INPUTS			OUTPUT
$\overline{OE}$	LE	D	$\overline{Q}$
L	H	H	L
L	H	L	H
L	L	X	$\overline{Q_0}$
H	X	X	Z

## logic diagram (positive logic)

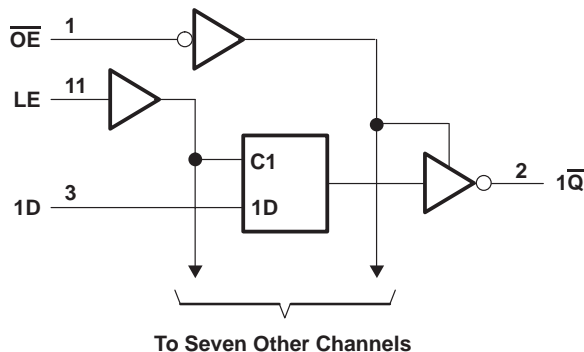

## absolute maximum ratings over operating free-air temperature range (unless otherwise noted)†

Supply voltage range, $V_{CC}$	-0.5 V to 7 V
Input voltage range, $V_I$ (see Note 1)	-0.5 V to $V_{CC} + 0.5$ V
Output voltage range, $V_O$ (see Note 1)	-0.5 V to $V_{CC} + 0.5$ V
Input clamp current, $I_{IK}$ ( $V_I < 0$ or $V_I > V_{CC}$ )	$\pm 20$ mA
Output clamp current, $I_{OK}$ ( $V_O < 0$ or $V_O > V_{CC}$ )	$\pm 20$ mA
Continuous output current, $I_O$ ( $V_O = 0$ to $V_{CC}$ )	$\pm 50$ mA
Continuous current through $V_{CC}$ or GND	$\pm 200$ mA
Package thermal impedance, $\theta_{JA}$ (see Note 2):	
DB package	70°C/W
DW package	58°C/W
N package	69°C/W
NS package	60°C/W
PW package	83°C/W
Storage temperature range, $T_{stg}$	-65°C to 150°C

† Stresses beyond those listed under "absolute maximum ratings" may cause permanent damage to the device. These are stress ratings only, and functional operation of the device at these or any other conditions beyond those indicated under "recommended operating conditions" is not implied. Exposure to absolute-maximum-rated conditions for extended periods may affect device reliability.

- NOTES: 1. The input and output voltage ratings may be exceeded if the input and output current ratings are observed.  
2. The package thermal impedance is calculated in accordance with JESD 51-7.

# SN54AC533, SN74AC533 OCTAL TRANSPARENT D-TYPE LATCHES WITH 3-STATE OUTPUTS

SCAS555C – NOVEMBER 1995 – REVISED OCTOBER 2003

## recommended operating conditions (see Note 3)

		SN54AC533		SN74AC533		UNIT
		MIN	MAX	MIN	MAX	
$V_{CC}$	Supply voltage	2	6	2	6	V
$V_{IH}$	High-level input voltage	$V_{CC} = 3\text{ V}$		2.1		V
		$V_{CC} = 4.5\text{ V}$		3.15		
		$V_{CC} = 5.5\text{ V}$		3.85		
$V_{IL}$	Low-level input voltage	$V_{CC} = 3\text{ V}$		0.9		V
		$V_{CC} = 4.5\text{ V}$		1.35		
		$V_{CC} = 5.5\text{ V}$		1.65		
$V_I$	Input voltage	0	$V_{CC}$	0	$V_{CC}$	V
$V_O$	Output voltage	0	$V_{CC}$	0	$V_{CC}$	V
$I_{OH}$	High-level output current	$V_{CC} = 3\text{ V}$		-12		mA
		$V_{CC} = 4.5\text{ V}$		-24		
		$V_{CC} = 5.5\text{ V}$		-24		
$I_{OL}$	Low-level output current	$V_{CC} = 3\text{ V}$		12		mA
		$V_{CC} = 4.5\text{ V}$		24		
		$V_{CC} = 5.5\text{ V}$		24		
$\Delta t/\Delta v$	Input transition rise or fall rate			8		ns/V
$T_A$	Operating free-air temperature	-55	125	-40	85	°C

NOTE 3: All unused inputs of the device must be held at  $V_{CC}$  or GND to ensure proper device operation. Refer to the TI application report, *Implications of Slow or Floating CMOS Inputs*, literature number SCBA004.

## electrical characteristics over recommended operating free-air temperature range (unless otherwise noted)

PARAMETER	TEST CONDITIONS	$V_{CC}$	$T_A = 25^\circ\text{C}$			SN54AC533		SN74AC533		UNIT
			MIN	TYP	MAX	MIN	MAX	MIN	MAX	
$V_{OH}$	$I_{OH} = -50\ \mu\text{A}$	3 V	2.9			2.9		2.9	V	
		4.5 V	4.4			4.4		4.4		
		5.5 V	5.4			5.4		5.4		
	$I_{OH} = -12\ \text{mA}$	3 V	2.56			2.4		2.46		
		4.5 V	3.86			3.7		3.76		
		5.5 V	4.86			4.7		4.76		
$V_{OL}$	$I_{OL} = 50\ \mu\text{A}$	3 V				0.1		0.1	V	
		4.5 V				0.1		0.1		
		5.5 V				0.1		0.1		
	$I_{OL} = 12\ \text{mA}$	3 V			0.36		0.5	0.44		
		4.5 V			0.36		0.5	0.44		
		5.5 V			0.36		0.5	0.44		
$I_{OZ}$	$V_O = V_{CC}$ or GND	5.5 V			$\pm 0.25$	$\pm 5$	$\pm 2.5$	$\mu\text{A}$		
$I_I$	$V_I = V_{CC}$ or GND	5.5 V			$\pm 0.1$	$\pm 1$	$\pm 1$	$\mu\text{A}$		
$I_{CC}$	$V_I = V_{CC}$ or GND, $I_O = 0$	5.5 V			4	80	40	$\mu\text{A}$		
$C_i$	$V_I = V_{CC}$ or GND	5 V		4.5				pF		

PRODUCT PREVIEW information concerns products in the formative or design phase of development. Characteristic data and other specifications are design goals. Texas Instruments reserves the right to change or discontinue these products without notice.



# SN54AC533, SN74AC533 OCTAL TRANSPARENT D-TYPE LATCHES WITH 3-STATE OUTPUTS

SCAS555C – NOVEMBER 1995 – REVISED OCTOBER 2003

timing requirements over recommended operating free-air temperature range,  $V_{CC} = 3.3 V \pm 0.3 V$  (unless otherwise noted) (see Figure 1)

		$T_A = 25^\circ C$		SN54AC533		SN74AC533		UNIT
		MIN	MAX	MIN	MAX	MIN	MAX	
$t_w$	Pulse duration, LE high	6		8		6.5		ns
$t_{su}$	Setup time, data before LE $\downarrow$	5.5		7.5		6		ns
$t_h$	Hold time, data after LE $\downarrow$	1.5		2.5		1		ns

timing requirements over recommended operating free-air temperature range,  $V_{CC} = 5 V \pm 0.5 V$  (unless otherwise noted) (see Figure 1)

		$T_A = 25^\circ C$		SN54AC533		SN74AC533		UNIT
		MIN	MAX	MIN	MAX	MIN	MAX	
$t_w$	Pulse duration, LE high	4.5		6.5		5		ns
$t_{su}$	Setup time, data before LE $\downarrow$	4		6		4.5		ns
$t_h$	Hold time, data after LE $\downarrow$	1.5		2.5		1		ns

switching characteristics over recommended operating free-air temperature range,  $V_{CC} = 3.3 V \pm 0.3 V$  (unless otherwise noted) (see Figure 1)

PARAMETER	FROM (INPUT)	TO (OUTPUT)	$T_A = 25^\circ C$		SN54AC533		SN74AC533		UNIT
			MIN	MAX	MIN	MAX	MIN	MAX	
$t_{PLH}$	D	$\bar{Q}$	2	14	1	17.5	1.5	16	ns
$t_{PHL}$			2	13	1	16	1.5	14.5	
$t_{PLH}$	LE	$\bar{Q}$	2	14.5	1	18	1.5	16.5	ns
$t_{PHL}$			2	13	1	16	1.5	14.5	
$t_{PZH}$	$\overline{OE}$	$\bar{Q}$	2	12.5	1	15.5	1.5	14	ns
$t_{PZL}$			2	12.5	1	15.5	1.5	14	
$t_{PHZ}$	$\overline{OE}$	$\bar{Q}$	2	13	1	16	1.5	14.5	ns
$t_{PLZ}$			2	13	1	16	1.5	14.5	

switching characteristics over recommended operating free-air temperature range,  $V_{CC} = 5 V \pm 0.5 V$  (unless otherwise noted) (see Figure 1)

PARAMETER	FROM (INPUT)	TO (OUTPUT)	$T_A = 25^\circ C$		SN54AC533		SN74AC533		UNIT
			MIN	MAX	MIN	MAX	MIN	MAX	
$t_{PLH}$	D	$\bar{Q}$	2	10	1	12.5	1.5	11	ns
$t_{PHL}$			2	9.5	1	12	1.5	10.5	
$t_{PLH}$	LE	$\bar{Q}$	2	10.5	1	13	1.5	11.5	ns
$t_{PHL}$			2	10	1	13	1.5	11	
$t_{PZH}$	$\overline{OE}$	$\bar{Q}$	2	9.5	1	12	1.5	10.5	ns
$t_{PZL}$			2	9.5	1	12	1.5	10.5	
$t_{PHZ}$	$\overline{OE}$	$\bar{Q}$	2	10	1	12.5	1.5	11	ns
$t_{PLZ}$			2	10	1	12.5	1.5	11	

operating characteristics,  $V_{CC} = 5 V, T_A = 25^\circ C$

PARAMETER	TEST CONDITIONS	TYP	UNIT
$C_{pd}$ Power dissipation capacitance	$C_L = 50 pF, f = 1 MHz$	40	pF

PRODUCT PREVIEW information concerns products in the formative or design phase of development. Characteristic data and other specifications are design goals. Texas Instruments reserves the right to change or discontinue these products without notice.



PARAMETER MEASUREMENT INFORMATION

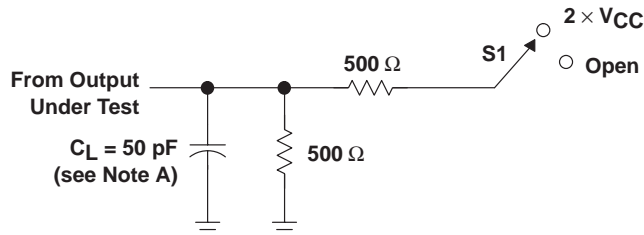

LOAD CIRCUIT

TEST	S1
$t_{PLH}/t_{PHL}$	Open
$t_{PLZ}/t_{PZL}$	$2 \times V_{CC}$
$t_{PHZ}/t_{PZH}$	Open

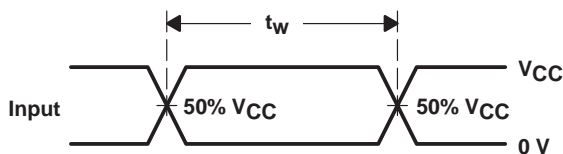

VOLTAGE WAVEFORMS

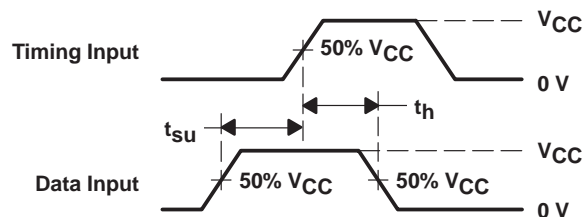

VOLTAGE WAVEFORMS

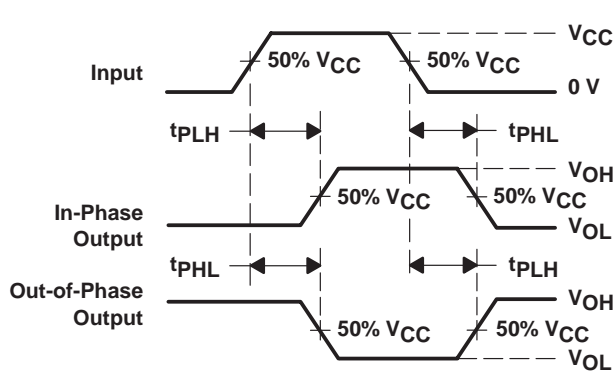

VOLTAGE WAVEFORMS

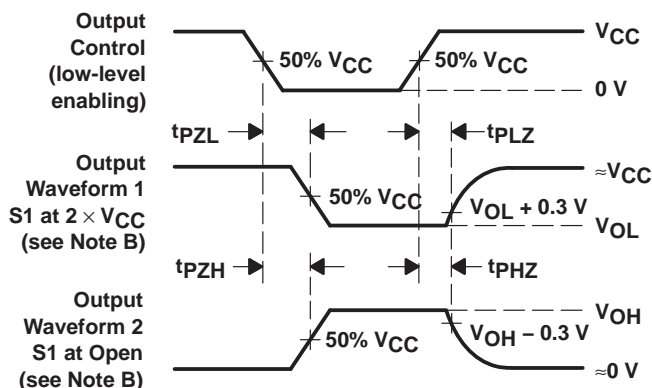

VOLTAGE WAVEFORMS

- NOTES: A.  $C_L$  includes probe and jig capacitance.  
 B. Waveform 1 is for an output with internal conditions such that the output is low except when disabled by the output control.  
 Waveform 2 is for an output with internal conditions such that the output is high except when disabled by the output control.  
 C. All input pulses are supplied by generators having the following characteristics:  $PRR \leq 1 \text{ MHz}$ ,  $Z_O = 50 \Omega$ ,  $t_r \leq 2.5 \text{ ns}$ ,  $t_f \leq 2.5 \text{ ns}$ .  
 D. The outputs are measured one at a time with one input transition per measurement.

Figure 1. Load Circuit and Voltage Waveforms

**PACKAGING INFORMATION**

Orderable Device	Status (1)	Package Type	Package Drawing	Pins	Package Qty	Eco Plan (2)	Lead finish/ Ball material (6)	MSL Peak Temp (3)	Op Temp (°C)	Device Marking (4/5)	Samples
SN74AC533DW	ACTIVE	SOIC	DW	20	25	RoHS & Green	NIPDAU	Level-1-260C-UNLIM	-40 to 85	AC533	Samples

(1) The marketing status values are defined as follows:

**ACTIVE:** Product device recommended for new designs.

**LIFEBUY:** TI has announced that the device will be discontinued, and a lifetime-buy period is in effect.

**NRND:** Not recommended for new designs. Device is in production to support existing customers, but TI does not recommend using this part in a new design.

**PREVIEW:** Device has been announced but is not in production. Samples may or may not be available.

**OBSOLETE:** TI has discontinued the production of the device.

(2) **RoHS:** TI defines "RoHS" to mean semiconductor products that are compliant with the current EU RoHS requirements for all 10 RoHS substances, including the requirement that RoHS substance do not exceed 0.1% by weight in homogeneous materials. Where designed to be soldered at high temperatures, "RoHS" products are suitable for use in specified lead-free processes. TI may reference these types of products as "Pb-Free".

**RoHS Exempt:** TI defines "RoHS Exempt" to mean products that contain lead but are compliant with EU RoHS pursuant to a specific EU RoHS exemption.

**Green:** TI defines "Green" to mean the content of Chlorine (Cl) and Bromine (Br) based flame retardants meet JS709B low halogen requirements of <=1000ppm threshold. Antimony trioxide based flame retardants must also meet the <=1000ppm threshold requirement.

(3) MSL, Peak Temp. - The Moisture Sensitivity Level rating according to the JEDEC industry standard classifications, and peak solder temperature.

(4) There may be additional marking, which relates to the logo, the lot trace code information, or the environmental category on the device.

(5) Multiple Device Markings will be inside parentheses. Only one Device Marking contained in parentheses and separated by a "-" will appear on a device. If a line is indented then it is a continuation of the previous line and the two combined represent the entire Device Marking for that device.

(6) Lead finish/Ball material - Orderable Devices may have multiple material finish options. Finish options are separated by a vertical ruled line. Lead finish/Ball material values may wrap to two lines if the finish value exceeds the maximum column width.

**Important Information and Disclaimer:** The information provided on this page represents TI's knowledge and belief as of the date that it is provided. TI bases its knowledge and belief on information provided by third parties, and makes no representation or warranty as to the accuracy of such information. Efforts are underway to better integrate information from third parties. TI has taken and continues to take reasonable steps to provide representative and accurate information but may not have conducted destructive testing or chemical analysis on incoming materials and chemicals. TI and TI suppliers consider certain information to be proprietary, and thus CAS numbers and other limited information may not be available for release.

In no event shall TI's liability arising out of such information exceed the total purchase price of the TI part(s) at issue in this document sold by TI to Customer on an annual basis.

**TUBE**

\*All dimensions are nominal

Device	Package Name	Package Type	Pins	SPQ	L (mm)	W (mm)	T (μm)	B (mm)
SN74AC533DW	DW	SOIC	20	25	507	12.83	5080	6.6

# DW0020A



# PACKAGE OUTLINE

## SOIC - 2.65 mm max height

SOIC

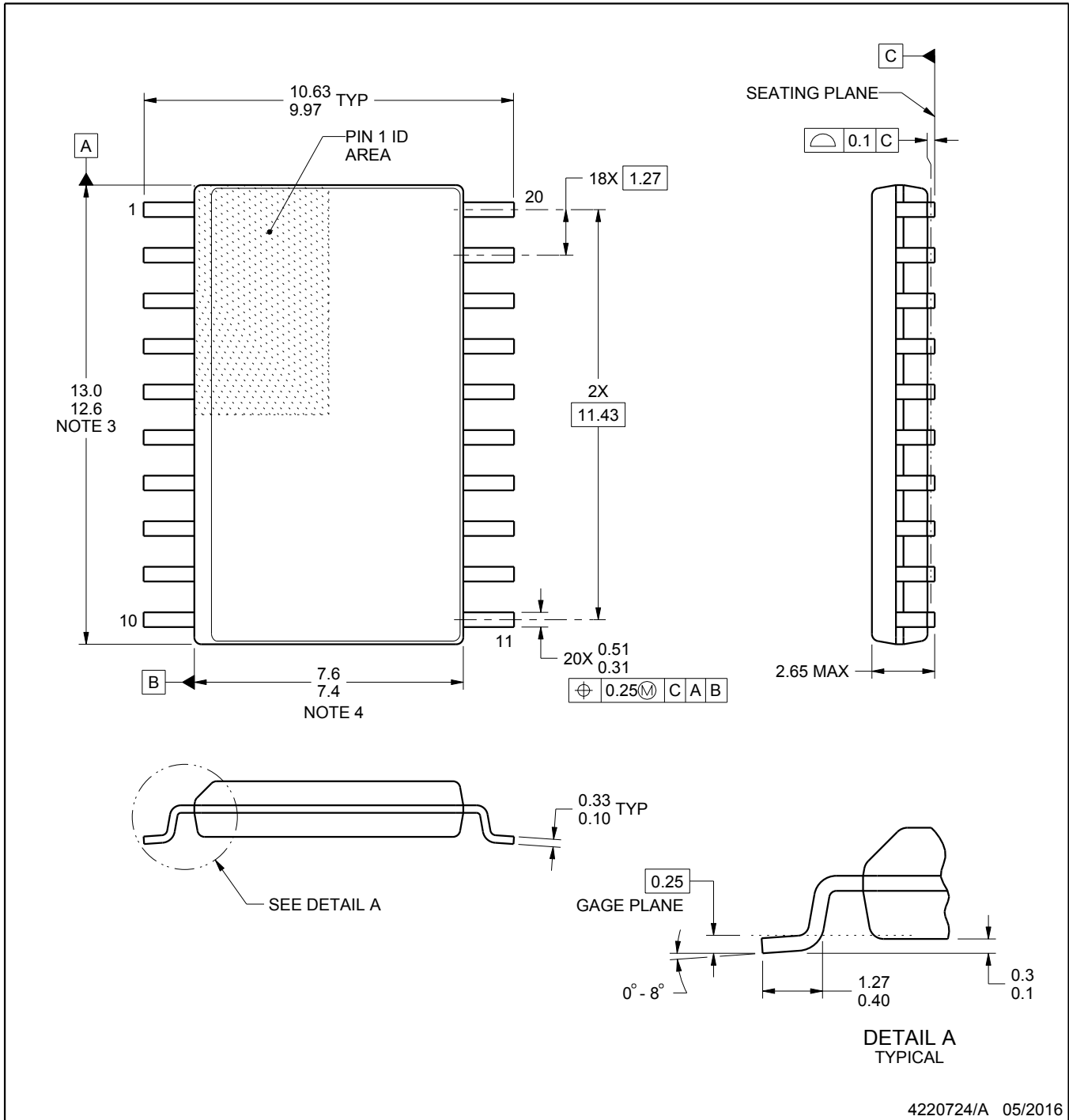

4220724/A 05/2016

**NOTES:**

1. All linear dimensions are in millimeters. Dimensions in parenthesis are for reference only. Dimensioning and tolerancing per ASME Y14.5M.
2. This drawing is subject to change without notice.
3. This dimension does not include mold flash, protrusions, or gate burrs. Mold flash, protrusions, or gate burrs shall not exceed 0.15 mm per side.
4. This dimension does not include interlead flash. Interlead flash shall not exceed 0.43 mm per side.
5. Reference JEDEC registration MS-013.

# EXAMPLE BOARD LAYOUT

DW0020A

SOIC - 2.65 mm max height

SOIC

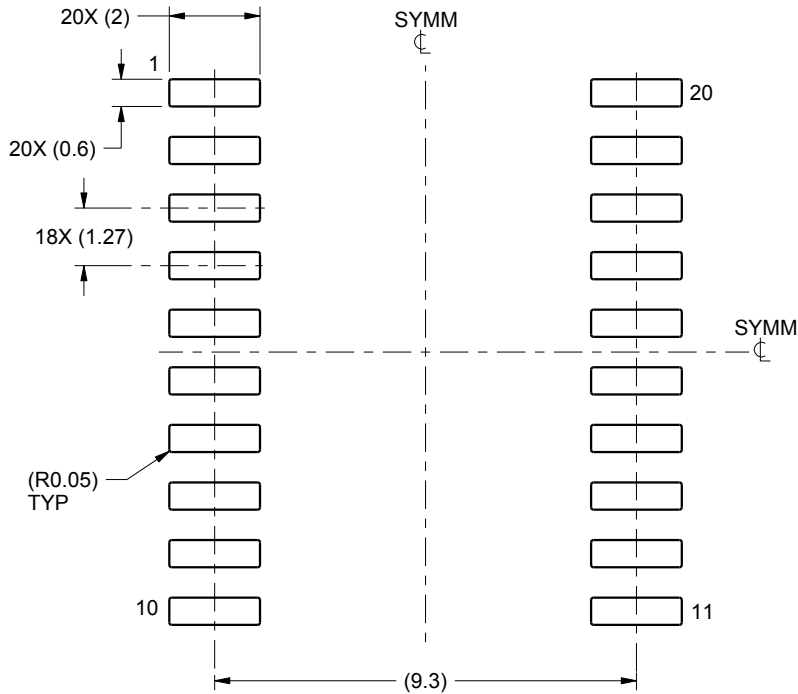

LAND PATTERN EXAMPLE  
SCALE:6X

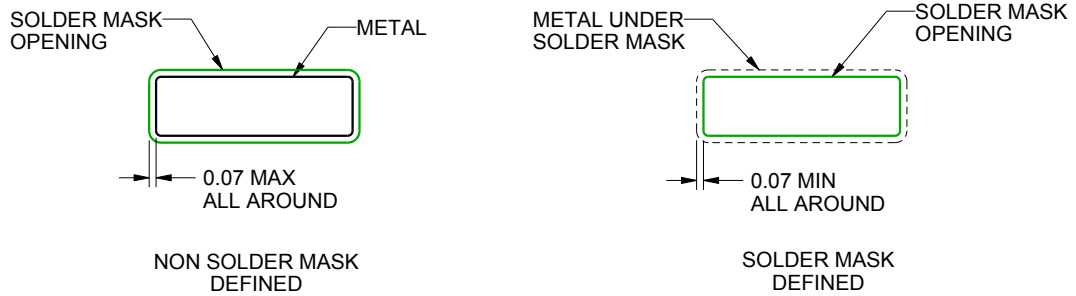

SOLDER MASK DETAILS

4220724/A 05/2016

NOTES: (continued)

- 6. Publication IPC-7351 may have alternate designs.
- 7. Solder mask tolerances between and around signal pads can vary based on board fabrication site.

# EXAMPLE STENCIL DESIGN

DW0020A

SOIC - 2.65 mm max height

SOIC

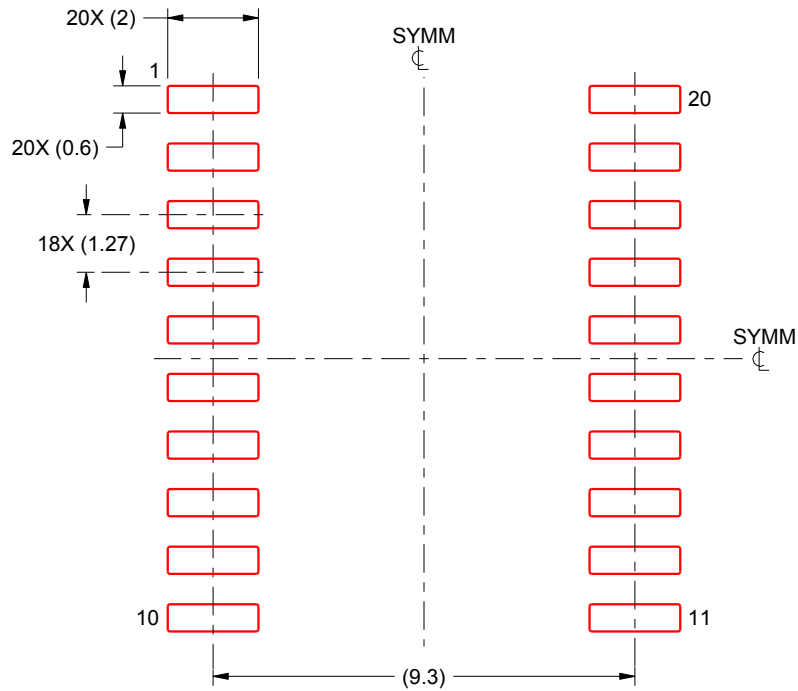

SOLDER PASTE EXAMPLE  
BASED ON 0.125 mm THICK STENCIL  
SCALE:6X

4220724/A 05/2016

NOTES: (continued)

8. Laser cutting apertures with trapezoidal walls and rounded corners may offer better paste release. IPC-7525 may have alternate design recommendations.
9. Board assembly site may have different recommendations for stencil design.

## IMPORTANT NOTICE AND DISCLAIMER

TI PROVIDES TECHNICAL AND RELIABILITY DATA (INCLUDING DATA SHEETS), DESIGN RESOURCES (INCLUDING REFERENCE DESIGNS), APPLICATION OR OTHER DESIGN ADVICE, WEB TOOLS, SAFETY INFORMATION, AND OTHER RESOURCES "AS IS" AND WITH ALL FAULTS, AND DISCLAIMS ALL WARRANTIES, EXPRESS AND IMPLIED, INCLUDING WITHOUT LIMITATION ANY IMPLIED WARRANTIES OF MERCHANTABILITY, FITNESS FOR A PARTICULAR PURPOSE OR NON-INFRINGEMENT OF THIRD PARTY INTELLECTUAL PROPERTY RIGHTS.

These resources are intended for skilled developers designing with TI products. You are solely responsible for (1) selecting the appropriate TI products for your application, (2) designing, validating and testing your application, and (3) ensuring your application meets applicable standards, and any other safety, security, regulatory or other requirements.

These resources are subject to change without notice. TI grants you permission to use these resources only for development of an application that uses the TI products described in the resource. Other reproduction and display of these resources is prohibited. No license is granted to any other TI intellectual property right or to any third party intellectual property right. TI disclaims responsibility for, and you will fully indemnify TI and its representatives against, any claims, damages, costs, losses, and liabilities arising out of your use of these resources.

TI's products are provided subject to [TI's Terms of Sale](#) or other applicable terms available either on [ti.com](http://ti.com) or provided in conjunction with such TI products. TI's provision of these resources does not expand or otherwise alter TI's applicable warranties or warranty disclaimers for TI products.

TI objects to and rejects any additional or different terms you may have proposed.

Mailing Address: Texas Instruments, Post Office Box 655303, Dallas, Texas 75265  
Copyright © 2022, Texas Instruments Incorporated

## Looking for pricing, stock, or lifecycle information?

Click below to explore more details on WIN SOURCE:

 [View SN74AC533NSRE4 on WIN SOURCE](#)

 [Texas Instruments](#) Information

## Optimize Your Supply Chain with WIN SOURCE Solutions

-  Global Sourcing Solution
-  Obsolete Management
-  Cost Control Management
-  Shortage Management
-  Alternative Solution
-  Excess Inventory Management