



**THE DATASHEET OF
74LVC1G123DP-Q100H**



74LVC1G123-Q100

Single retriggerable monostable multivibrator;
Schmitt trigger inputs

Rev. 5 — 14 August 2023

Product data sheet

1. General description

The 74LVC1G123-Q100 is a single retriggerable monostable multivibrator with Schmitt trigger inputs. Output pulse width is controlled by three methods:

1. The basic pulse is programmed by selection of an external resistor (R_{EXT}) and capacitor (C_{EXT}).
2. Once triggered, the basic output pulse width may be extended by retriggering the gated active LOW-going edge input (\overline{A}) or the active HIGH-going edge input (B). By repeating this process, the output pulse period ($Q = \text{HIGH}$) can be made as long as desired. Alternatively an output delay can be terminated at any time by a LOW-going edge on input \overline{CLR} , which also inhibits the triggering.
3. An internal connection from \overline{CLR} to the input gates makes it possible to trigger the circuit by a HIGH-going signal at input \overline{CLR} .

Inputs can be driven from either 3.3 V or 5 V devices. This feature allows the use of these devices as translators in a mixed 3.3 V and 5 V environment. Schmitt trigger inputs, makes the circuit highly tolerant to slower input rise and fall times.

This device is fully specified for partial power-down applications using I_{OFF} . The I_{OFF} circuitry disables the output, preventing the damaging backflow current through the device when it is powered down.

This product has been qualified to the Automotive Electronics Council (AEC) standard Q100 (Grade 1) and is suitable for use in automotive applications.

2. Features and benefits

- Automotive product qualification in accordance with AEC-Q100 (Grade 1)
 - Specified from $-40\text{ }^{\circ}\text{C}$ to $+85\text{ }^{\circ}\text{C}$ and from $-40\text{ }^{\circ}\text{C}$ to $+125\text{ }^{\circ}\text{C}$
- Wide supply voltage range from 1.65 V to 5.5 V
- High noise immunity
- $\pm 24\text{ mA}$ output drive ($V_{CC} = 3.0\text{ V}$)
- CMOS low power consumption
- DC triggered from active HIGH or active LOW inputs
- Retriggerable for very long pulses up to 100 % duty factor
- Direct reset terminates output pulse
- Schmitt trigger on all inputs
- Complies with JEDEC standard:
 - JESD8-7 (1.65 V to 1.95 V)
 - JESD8-5 (2.3 V to 2.7 V)
 - JESD8-B/JESD36 (2.7 V to 3.6 V)
- Power-on-reset on outputs
- Latch-up performance exceeds 100 mA
- Direct interface with TTL levels
- Inputs accept voltages up to 5.5 V
- ESD protection:
 - HBM: ANSI/ESDA/JEDEC JS-001 class 2 exceeds 2000 V
 - CDM: ANSI/ESDA/JEDEC JS-002 class C3 exceeds 1000 V

3. Ordering information

Table 1. Ordering information

Type number	Package			Version
	Temperature range	Name	Description	
74LVC1G123DP-Q100	-40 °C to +125 °C	TSSOP8	plastic thin shrink small outline package; 8 leads; body width 3 mm; lead length 0.5 mm	SOT505-2
74LVC1G123DC-Q100	-40 °C to +125 °C	VSSOP8	plastic very thin shrink small outline package; 8 leads; body width 2.3 mm	SOT765-1

4. Marking

Table 2. Marking codes

Type number	Marking code ^[1]
74LVC1G123DP-Q100	Y3
74LVC1G123DC-Q100	Y3

[1] The pin 1 indicator is located on the lower left corner of the device, below the marking code.

5. Functional diagram

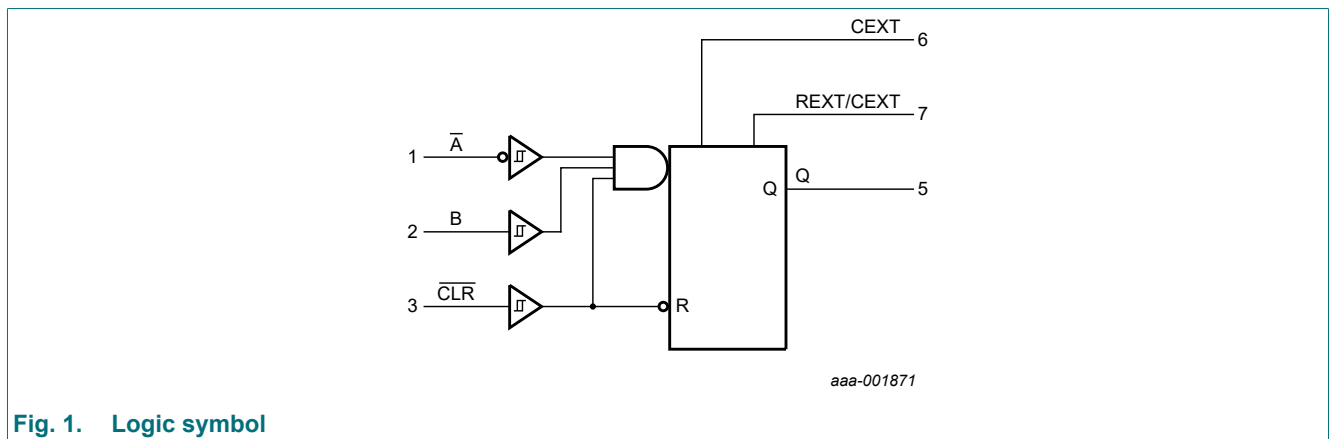

Fig. 1. Logic symbol

Single retriggerable monostable multivibrator; Schmitt trigger inputs

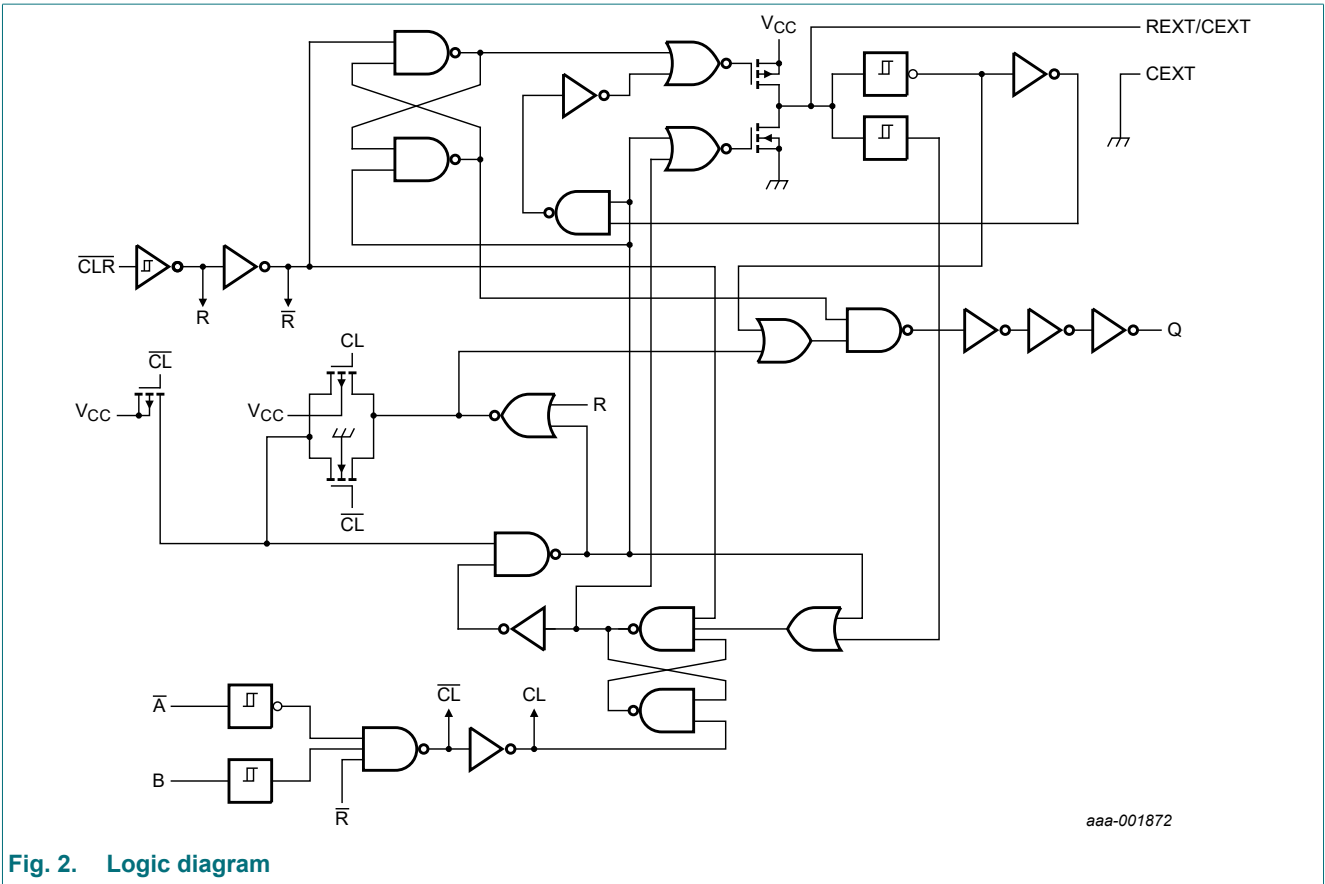

Fig. 2. Logic diagram

6. Pinning information

6.1. Pinning

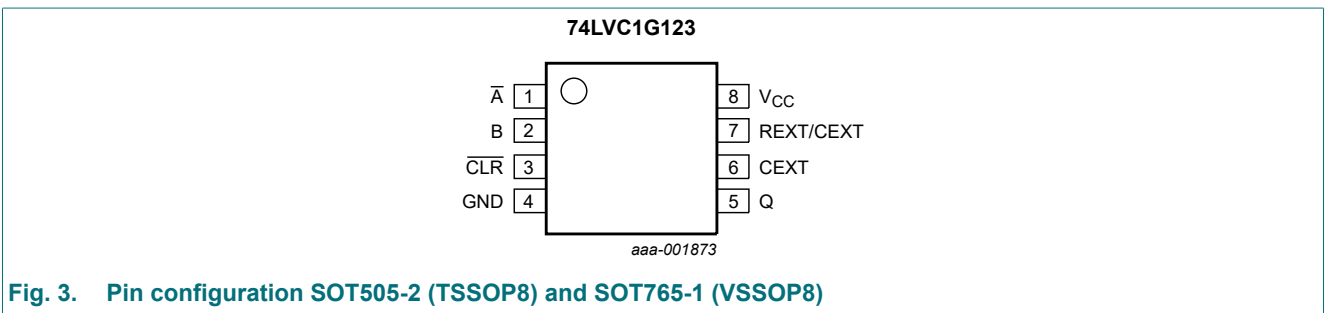

Fig. 3. Pin configuration SOT505-2 (TSSOP8) and SOT765-1 (VSSOP8)

6.2. Pin description

Table 3. Pin description

Symbol	Pin	Description
\bar{A}	1	negative-edge triggered input
B	2	positive-edge triggered input
$\overline{\text{CLR}}$	3	direct reset LOW and positive-edge triggered input
GND	4	ground (0 V)
Q	5	active HIGH output
CEXT	6	external capacitor connection
REXT/CEXT	7	external resistor and capacitor connection
V _{CC}	8	supply voltage

7. Functional description

Table 4. Function table

H = HIGH voltage level; L = LOW voltage level; X = don't care; \uparrow = LOW-to-HIGH transition; \downarrow = HIGH-to-LOW transition; \square = one HIGH level output pulse.

Input			Output
CLR	\bar{A}	B	Q
L	X	X	L
X	H	X	L ^[1]
X	X	L	L ^[1]
H	L	\uparrow	\square
H	\downarrow	H	\square
\uparrow	L	H	\square

[1] If the monostable was triggered before this condition was established, the pulse continues as programmed.

8. Limiting values

Table 5. Limiting values

In accordance with the Absolute Maximum Rating System (IEC 60134). Voltages are referenced to GND (ground = 0 V).

Symbol	Parameter	Conditions	Min	Max	Unit
V _{CC}	supply voltage		-0.5	+6.5	V
V _I	input voltage	[1]	-0.5	+6.5	V
V _O	output voltage	Active mode	[1]	V _{CC} + 0.5	V
		Power-down mode; V _{CC} = 0 V	[1]	+6.5	V
I _{IK}	input clamping current	V _I < 0 V	-50	-	mA
I _{OK}	output clamping current	V _O < 0 V or V _O > V _{CC}	-	±50	mA
I _O	output current	V _O = 0 V to V _{CC}	-	±50	mA
I _{CC}	supply current		-	100	mA
I _{GND}	ground current		-100	-	mA
T _{stg}	storage temperature		-65	+150	°C

Single retriggerable monostable multivibrator; Schmitt trigger inputs

Symbol	Parameter	Conditions	Min	Max	Unit
P_{tot}	total power dissipation	$T_{\text{amb}} = -40\text{ °C to }+125\text{ °C}$ [2]	-	250	mW

[1] The input and output voltage ratings may be exceeded if the input and output current ratings are observed.

[2] For SOT505-2 (TSSOP8) package: P_{tot} derates linearly with 4.6 mW/K above 96 °C.
For SOT765-1 (VSSOP8) package: P_{tot} derates linearly with 4.9 mW/K above 99 °C.

9. Recommended operating conditions

Table 6. Operating conditions

Symbol	Parameter	Conditions	Min	Max	Unit
V_{CC}	supply voltage		1.65	5.5	V
V_{I}	input voltage		0	5.5	V
V_{O}	output voltage	Active mode	0	V_{CC}	V
		Power-down mode; $V_{\text{CC}} = 0\text{ V}$	0	5.5	V
T_{amb}	ambient temperature		-40	+125	°C
$\Delta t/\Delta V$	input transition rise and fall rate	$V_{\text{CC}} = 1.65\text{ V to }5.5\text{ V}$	-	1	ms/V

10. Static characteristics

Table 7. Static characteristics

At recommended operating conditions; voltages are referenced to GND (ground = 0 V).

Symbol	Parameter	Conditions	Min	Typ[1]	Max	Unit
$T_{\text{amb}} = -40\text{ °C to }+85\text{ °C}$						
V_{OH}	HIGH-level output voltage	$V_{\text{I}} = V_{\text{T+}}$ or $V_{\text{T-}}$				
		$I_{\text{O}} = -100\text{ }\mu\text{A}$; $V_{\text{CC}} = 1.65\text{ V to }5.5\text{ V}$	$V_{\text{CC}} - 0.1$	-	-	V
		$I_{\text{O}} = -4\text{ mA}$; $V_{\text{CC}} = 1.65\text{ V}$	1.2	-	-	V
		$I_{\text{O}} = -8\text{ mA}$; $V_{\text{CC}} = 2.3\text{ V}$	1.9	-	-	V
		$I_{\text{O}} = -12\text{ mA}$; $V_{\text{CC}} = 2.7\text{ V}$	2.2	-	-	V
		$I_{\text{O}} = -24\text{ mA}$; $V_{\text{CC}} = 3.0\text{ V}$	2.4	-	-	V
		$I_{\text{O}} = -32\text{ mA}$; $V_{\text{CC}} = 4.5\text{ V}$	3.8	-	-	V
V_{OL}	LOW-level output voltage	$V_{\text{I}} = V_{\text{T+}}$ or $V_{\text{T-}}$				
		$I_{\text{O}} = 100\text{ }\mu\text{A}$; $V_{\text{CC}} = 1.65\text{ V to }5.5\text{ V}$	-	-	0.1	V
		$I_{\text{O}} = 4\text{ mA}$; $V_{\text{CC}} = 1.65\text{ V}$	-	-	0.45	V
		$I_{\text{O}} = 8\text{ mA}$; $V_{\text{CC}} = 2.3\text{ V}$	-	-	0.3	V
		$I_{\text{O}} = 12\text{ mA}$; $V_{\text{CC}} = 2.7\text{ V}$	-	-	0.4	V
		$I_{\text{O}} = 24\text{ mA}$; $V_{\text{CC}} = 3.0\text{ V}$	-	-	0.55	V
		$I_{\text{O}} = 32\text{ mA}$; $V_{\text{CC}} = 4.5\text{ V}$	-	-	0.55	V
I_{I}	input leakage current	$V_{\text{I}} = 5.5\text{ V or GND}$; $V_{\text{CC}} = 0\text{ V to }5.5\text{ V}$	-	-	± 2	μA
I_{OFF}	power-off leakage current	V_{I} or $V_{\text{O}} = 5.5\text{ V}$; $V_{\text{CC}} = 0\text{ V}$	-	-	± 2	μA

Single retriggerable monostable multivibrator; Schmitt trigger inputs

Symbol	Parameter	Conditions	Min	Typ[1]	Max	Unit
I _{CC}	supply current	V _I = 5.5 V or GND;				
		Quiescent; V _{CC} = 1.65 V to 5.5 V; I _O = 0 A	-	0.1	10	μA
		Active state; R _{EXT} /C _{EXT} = 0.5V _{CC}				
		V _{CC} = 1.65 V	-	-	80	μA
		V _{CC} = 2.3 V	-	-	130	μA
		V _{CC} = 3 V	-	-	240	μA
		V _{CC} = 4.5 V	-	-	400	μA
		V _{CC} = 5.5 V	-	-	650	μA
C _I	input capacitance		-	2.0	-	pF
T_{amb} = -40 °C to +125 °C						
V _{OH}	HIGH-level output voltage	V _I = V _{T+} or V _{T-}				
		I _O = -100 μA; V _{CC} = 1.65 V to 5.5 V	V _{CC} - 0.1	-	-	V
		I _O = -4 mA; V _{CC} = 1.65 V	1.2	-	-	V
		I _O = -8 mA; V _{CC} = 2.3 V	1.9	-	-	V
		I _O = -12 mA; V _{CC} = 2.7 V	2.2	-	-	V
		I _O = -24 mA; V _{CC} = 3.0 V	2.4	-	-	V
		I _O = -32 mA; V _{CC} = 4.5 V	3.8	-	-	V
V _{OL}	LOW-level output voltage	V _I = V _{T+} or V _{T-}				
		I _O = 100 μA; V _{CC} = 1.65 V to 5.5 V	-	-	0.1	V
		I _O = 4 mA; V _{CC} = 1.65 V	-	-	0.45	V
		I _O = 8 mA; V _{CC} = 2.3 V	-	-	0.3	V
		I _O = 12 mA; V _{CC} = 2.7 V	-	-	0.4	V
		I _O = 24 mA; V _{CC} = 3.0 V	-	-	0.55	V
		I _O = 32 mA; V _{CC} = 4.5 V	-	-	0.55	V
I _I	input leakage current	V _I = 5.5 V or GND; V _{CC} = 0 V to 5.5 V	-	-	±10	μA
I _{OFF}	power-off leakage current	V _I or V _O = 5.5 V; V _{CC} = 0 V	-	-	±10	μA
I _{CC}	supply current	V _I = 5.5 V or GND;				
		Quiescent; V _{CC} = 1.65 V to 5.5 V; I _O = 0 A	-	-	20	μA
		Active state; R _{EXT} /C _{EXT} = 0.5V _{CC}				
		V _{CC} = 1.65 V	-	-	80	μA
		V _{CC} = 2.3 V	-	-	130	μA
		V _{CC} = 3 V	-	-	240	μA
		V _{CC} = 4.5 V	-	-	400	μA
		V _{CC} = 5.5 V	-	-	650	μA

[1] All typical values are measured at T_{amb} = 25 °C.

Single retriggerable monostable multivibrator; Schmitt trigger inputs

Table 8. Transfer characteristics

Voltages are referenced to GND (ground = 0 V); for test circuit see Fig. 16.

Symbol	Parameter	Conditions	-40 °C to +85 °C			-40 °C to +125 °C		Unit
			Min	Typ[1]	Max	Min	Max	
V _{T+}	positive-going threshold voltage	\bar{A} , B and \bar{CLR} input; see Fig. 4						
		V _{CC} = 1.65 V to 1.95 V	0.72	0.98	1.22	0.71	1.22	V
		V _{CC} = 2.3 V to 2.7 V	0.97	1.26	1.52	0.97	1.52	V
		V _{CC} = 3.0 V to 3.6 V	1.20	1.58	1.90	1.20	1.90	V
		V _{CC} = 4.5 V to 5.5 V	1.74	2.27	2.75	1.74	2.78	V
V _{T-}	negative-going threshold voltage	\bar{A} , B and \bar{CLR} input; see Fig. 4						
		V _{CC} = 1.65 V to 1.95 V	0.56	0.81	1.04	0.56	1.04	V
		V _{CC} = 2.3 V to 2.7 V	0.83	1.09	1.33	0.82	1.33	V
		V _{CC} = 3.0 V to 3.6 V	1.08	1.40	1.70	1.08	1.72	V
		V _{CC} = 4.5 V to 5.5 V	1.61	2.07	2.53	1.61	2.57	V
V _H	hysteresis voltage	\bar{A} , B and \bar{CLR} input; (V _{T+} - V _{T-}); see Fig. 4						
		V _{CC} = 1.65 V to 1.95 V	61	170	295	54	295	mV
		V _{CC} = 2.3 V to 2.7 V	41	174	304	41	304	mV
		V _{CC} = 3.0 V to 3.6 V	40	183	319	40	319	mV
		V _{CC} = 4.5 V to 5.5 V	32	199	363	26	363	mV

[1] Typical values are measured at T_{amb} = 25 °C and V_{CC} = 1.8 V, 2.5 V, 3.3 V and 5.0 V respectively.

10.1. Waveform transfer characteristics

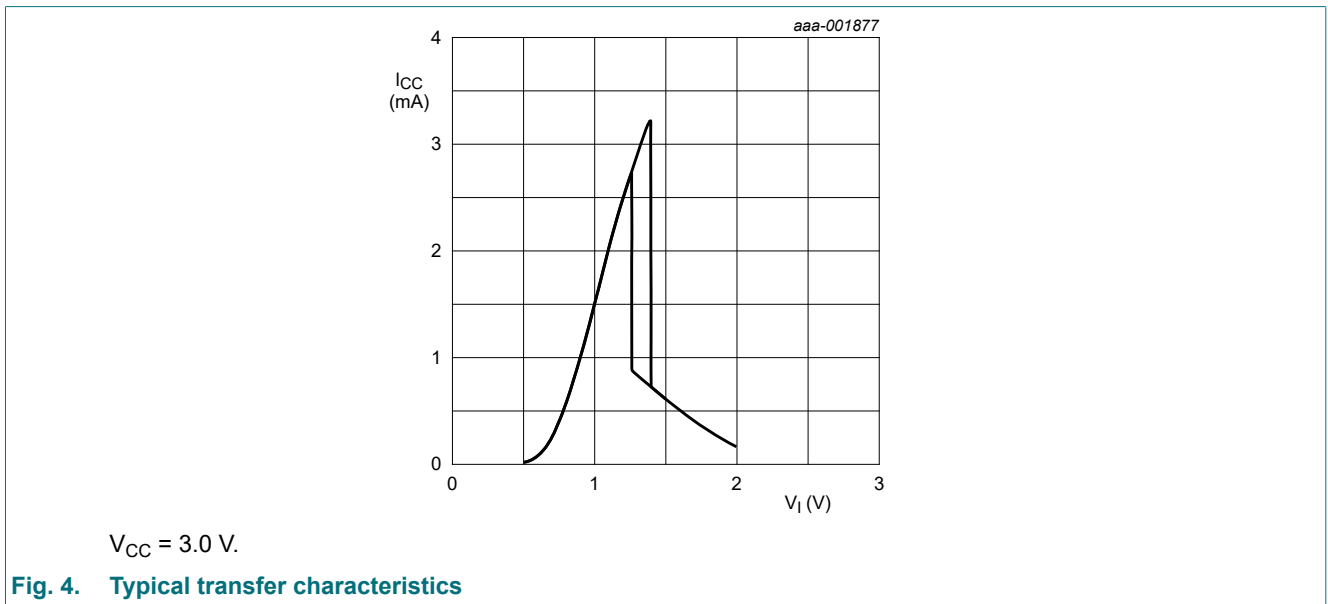

11. Dynamic characteristics

Table 9. Dynamic characteristics

Voltages are referenced to GND (ground = 0 V); for test circuit see Fig. 16.

Symbol	Parameter	Conditions	-40 °C to +85 °C			-40 °C to +125 °C		Unit
			Min	Typ[1]	Max	Min	Max	
t _{pd}	propagation delay	\bar{A} , B to Q; see Fig. 5 [2]						
		C _L = 15 pF;						
		V _{CC} = 1.65 V to 1.95 V	2.5	7.1	16.3	2.5	17.6	ns
		V _{CC} = 2.3 V to 2.7 V	1.9	-	10.3	1.9	11.2	ns
		V _{CC} = 2.7 V	1.9	-	8.5	1.9	9.3	ns
		V _{CC} = 3.0 V to 3.6 V	1.5	-	7.6	1.5	8.3	ns
		V _{CC} = 4.5 V to 5.5 V	1.2	-	5.3	1.2	5.8	ns
		C _L = 30 pF or C _L = 50 pF						
		V _{CC} = 1.65 V to 1.95 V	2.9	7.8	17.6	2.9	19.0	ns
		V _{CC} = 2.3 V to 2.7 V	2.2	-	11.3	2.2	12.3	ns
		V _{CC} = 2.7 V	2.7	-	10.5	2.7	11.4	ns
		V _{CC} = 3.0 V to 3.6 V	2.0	-	9.5	2.0	10.3	ns
		V _{CC} = 4.5 V to 5.5 V	1.5	-	6.7	1.5	7.2	ns
		\bar{CLR} to Q; see Fig. 5						
		C _L = 15 pF;						
		V _{CC} = 1.65 V to 1.95 V	3.0	6.9	16.2	3.0	17.4	ns
		V _{CC} = 2.3 V to 2.7 V	2.2	-	9.6	2.2	10.5	ns
		V _{CC} = 2.7 V	2.2	-	8.2	2.2	8.9	ns
		V _{CC} = 3.0 V to 3.6 V	2.0	-	7.3	2.0	8.0	ns
		V _{CC} = 4.5 V to 5.5 V	1.5	-	5.1	1.5	5.5	ns
		C _L = 30 pF or C _L = 50 pF						
		V _{CC} = 1.65 V to 1.95 V	3.3	7.5	17.2	3.8	18.6	ns
		V _{CC} = 2.3 V to 2.7 V	2.5	-	10.3	2.0	11.2	ns
V _{CC} = 2.7 V	2.8	-	9.3	2.8	10.2	ns		
V _{CC} = 3.0 V to 3.6 V	1.5	-	8.4	1.5	9.2	ns		
V _{CC} = 4.5 V to 5.5 V	1.5	-	6.0	1.5	6.6	ns		
t _{pd}	propagation delay	\bar{CLR} to Q (trigger); see Fig. 5 [2]						
		C _L = 15 pF;						
		V _{CC} = 1.65 V to 1.95 V	2.7	7.6	17.4	2.7	18.9	ns
		V _{CC} = 2.3 V to 2.7 V	2.1	-	11.0	2.1	12.0	ns
		V _{CC} = 2.7 V	2.1	-	9.2	2.1	10.0	ns
		V _{CC} = 3.0 V to 3.6 V	1.7	-	8.2	1.7	8.9	ns
		V _{CC} = 4.5 V to 5.5 V	1.4	-	5.9	1.4	6.4	ns
		C _L = 30 pF or C _L = 50 pF						
		V _{CC} = 1.65 V to 1.95 V	3.1	8.3	18.8	3.3	20.3	ns
		V _{CC} = 2.3 V to 2.7 V	2.5	-	12.0	2.5	13.1	ns
		V _{CC} = 2.7 V	2.8	-	11.1	2.8	12.1	ns
		V _{CC} = 3.0 V to 3.6 V	2.0	-	10.1	2.0	11.0	ns
		V _{CC} = 4.5 V to 5.5 V	1.5	-	7.1	1.5	7.7	ns

Single retriggerable monostable multivibrator; Schmitt trigger inputs

Symbol	Parameter	Conditions	-40 °C to +85 °C			-40 °C to +125 °C		Unit
			Min	Typ[1]	Max	Min	Max	
t _w	pulse width	input \bar{A} LOW; B HIGH; see Fig. 5 and Fig. 6						
		V _{CC} = 1.65 V to 1.95 V	8.0	-	-	8.0	-	ns
		V _{CC} = 2.3 V to 2.7 V	4.0	-	-	4.0	-	ns
		V _{CC} = 2.7 V	3.0	-	-	3.0	-	ns
		V _{CC} = 3.0 V to 3.6 V	3.0	-	-	3.0	-	ns
		V _{CC} = 4.5 V to 5.5 V	2.5	-	-	2.5	-	ns
		input \bar{C} LR LOW; see Fig. 5 and Fig. 7						
		V _{CC} = 1.65 V to 1.95 V	8.0	-	-	8.0	-	ns
		V _{CC} = 2.3 V to 2.7 V	4.0	-	-	4.0	-	ns
		V _{CC} = 2.7 V	3.0	-	-	3.0	-	ns
		V _{CC} = 3.0 V to 3.6 V	3.0	-	-	3.0	-	ns
		V _{CC} = 4.5 V to 5.5 V	2.5	-	-	2.5	-	ns
t _w	pulse width	output Q HIGH; see Fig. 5, Fig. 6 and Fig. 7; [3] R _{EXT} = 10 kΩ						
		C _{EXT} = 100 pF						
		V _{CC} = 1.65 V to 1.95 V	-	1.4	2.2	-	2.2	μs
		V _{CC} = 2.3 V to 2.7 V	-	1.3	1.8	-	1.8	μs
		V _{CC} = 2.7 V	-	1.2	1.8	-	1.8	μs
		V _{CC} = 3.0 V to 3.6 V	-	1.2	1.8	-	1.8	μs
		V _{CC} = 4.5 V to 5.5 V	-	1.2	1.8	-	1.8	μs
		C _{EXT} = 0.01 μF [3]						
		V _{CC} = 1.65 V to 1.95 V	-	100	110	-	110	μs
		V _{CC} = 2.3 V to 2.7 V	-	100	110	-	110	μs
		V _{CC} = 2.7 V	-	100	110	-	110	μs
		V _{CC} = 3.0 V to 3.6 V	-	100	110	-	110	μs
		V _{CC} = 4.5 V to 5.5 V	-	100	110	-	110	μs
		C _{EXT} = 0.1 μF [3]						
		V _{CC} = 1.65 V to 1.95 V	-	1.0	1.05	-	1.05	ms
		V _{CC} = 2.7 V	-	1.0	1.05	-	1.05	ms
		V _{CC} = 3.0 V to 3.6 V	-	1.0	1.05	-	1.05	ms
		V _{CC} = 3.0 V to 3.6 V	-	1.0	1.05	-	1.05	ms
		V _{CC} = 4.5 V to 5.5 V	-	1.0	1.05	-	1.05	ms

Single retriggerable monostable multivibrator; Schmitt trigger inputs

Symbol	Parameter	Conditions	-40 °C to +85 °C			-40 °C to +125 °C		Unit
			Min	Typ[1]	Max	Min	Max	
t _{trig}	retrigger time	\bar{A} , B; see Fig. 6						
		C _{EXT} = 100 pF; R _{EXT} = 5 kΩ						
		V _{CC} = 1.65 V to 1.95 V	-	174	-	-	-	ns
		V _{CC} = 2.3 V to 2.7 V	-	59	-	-	-	ns
		C _{EXT} = 100 pF; R _{EXT} = 1 kΩ						
		V _{CC} = 3.0 V to 3.6 V	-	32	-	-	-	ns
		V _{CC} = 4.5 V to 5.5 V	-	20	-	-	-	ns
		C _{EXT} = 100 μF; R _{EXT} = 5 kΩ						
		V _{CC} = 1.65 V to 1.95 V	-	14	-	-	-	ms
		V _{CC} = 2.3 V to 2.7 V	-	10	-	-	-	ms
		C _{EXT} = 100 μF; R _{EXT} = 1 kΩ						
		V _{CC} = 3.0 V to 3.6 V	-	10	-	-	-	ms
V _{CC} = 4.5 V to 5.5 V	-	8	-	-	-	ms		
R _{ext}	external resistance	see Fig. 10, Fig. 11 and Fig. 12						
		V _{CC} = 2.0 V	5	-	-	-	-	kΩ
		V _{CC} ≥ 3.0 V	1	-	-	-	-	kΩ
C _{ext}	external capacitance	V _{CC} = 5.0 V; see Fig. 10, Fig. 11 and Fig. 12	-	-	-	-	-	pF
C _{PD}	power dissipation capacitance	V _I = GND to V _{CC} ; C _{EXT} = 0 pF;						
		R _{EXT} = 5 kΩ						
		V _{CC} = 1.8 V	-	35	-	-	-	pF
		V _{CC} = 2.5 V	-	35	-	-	-	pF
		R _{EXT} = 1 kΩ						
		V _{CC} = 3.3 V	-	27	-	-	-	pF
V _{CC} = 5.0 V	-	29	-	-	-	pF		

- [1] Typical values are measured at T_{amb} = 25 °C and V_{CC} = 1.8 V, 2.5 V, 3.3 V and 5.0 V respectively.
- [2] t_{pd} is the same as t_{PHL} and t_{PLH}
- [3] For other R_{EXT} and C_{EXT} combinations see Fig. 10, Fig. 11 and Fig. 12. If C_{EXT} > 10 nF, the next formula is valid.
 $t_W = K \times R_{EXT} \times C_{EXT}$, where:
 t_W = typical output pulse width in ns;
 R_{EXT} = external resistor in kΩ;
 C_{EXT} = external capacitor in pF;
 K = constant = 1; see Fig. 13 for typical "K" factor as function of V_{CC}.

11.1. Waveforms, graphs and test circuit

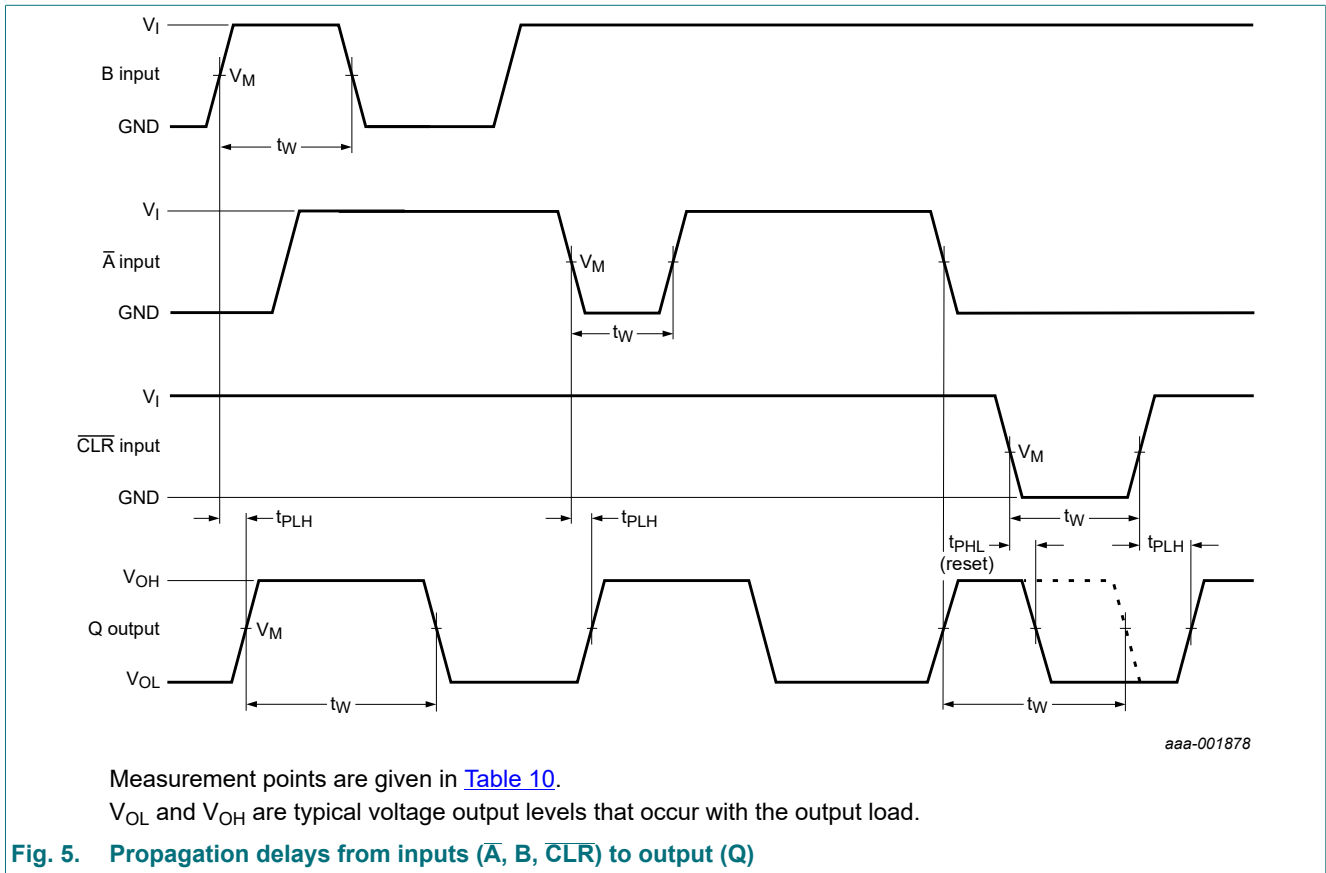
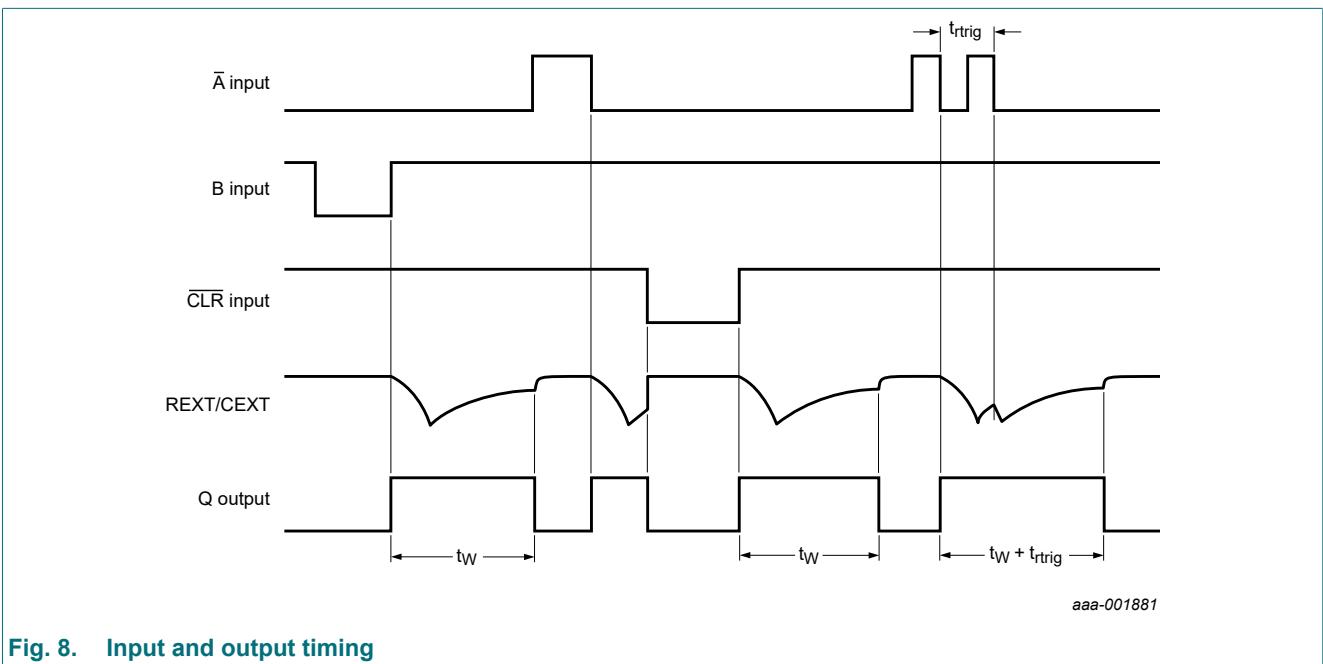
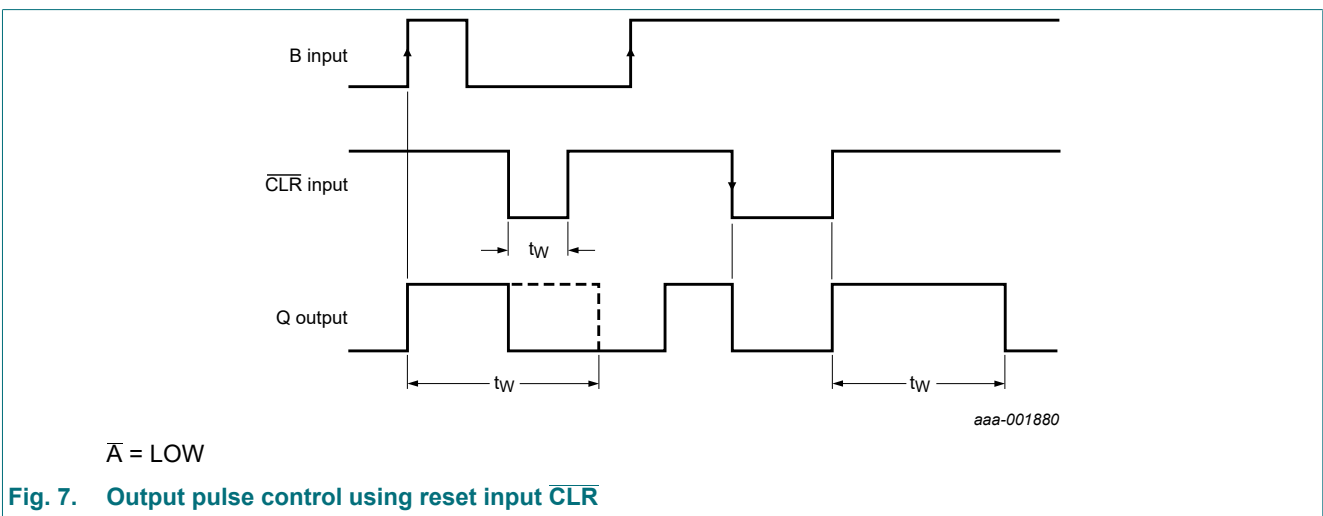
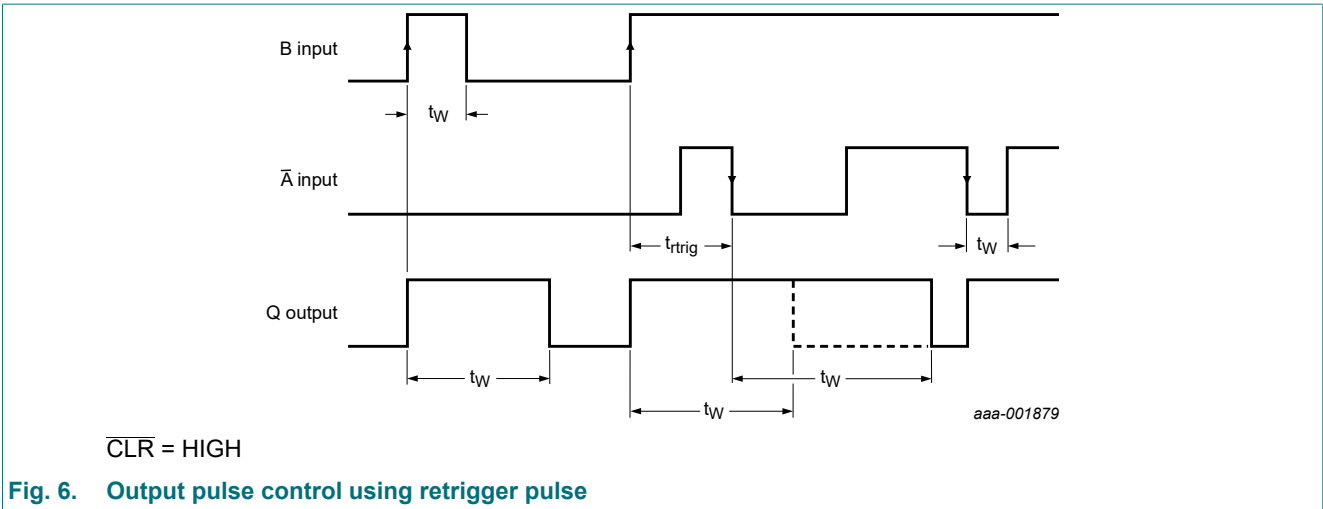

Fig. 5. Propagation delays from inputs (\bar{A} , B, \overline{CLR}) to output (Q)

Table 10. Measurement points

Supply voltage	Input	Output
V_{CC}	V_M	V_M
1.65 V to 1.95 V	$0.5V_{CC}$	$0.5V_{CC}$
2.3 V to 2.7 V	$0.5V_{CC}$	$0.5V_{CC}$
2.7 V	1.5 V	1.5 V
3.0 V to 3.6 V	1.5 V	1.5 V
4.5 V to 5.5 V	$0.5V_{CC}$	$0.5V_{CC}$

Single retriggerable monostable multivibrator; Schmitt trigger inputs



Single retriggerable monostable multivibrator; Schmitt trigger inputs

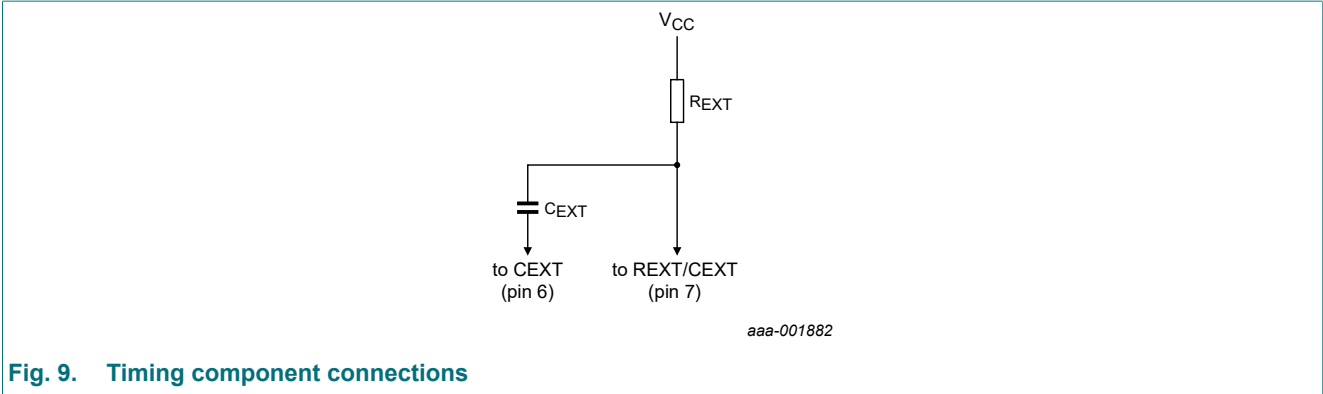

Fig. 9. Timing component connections

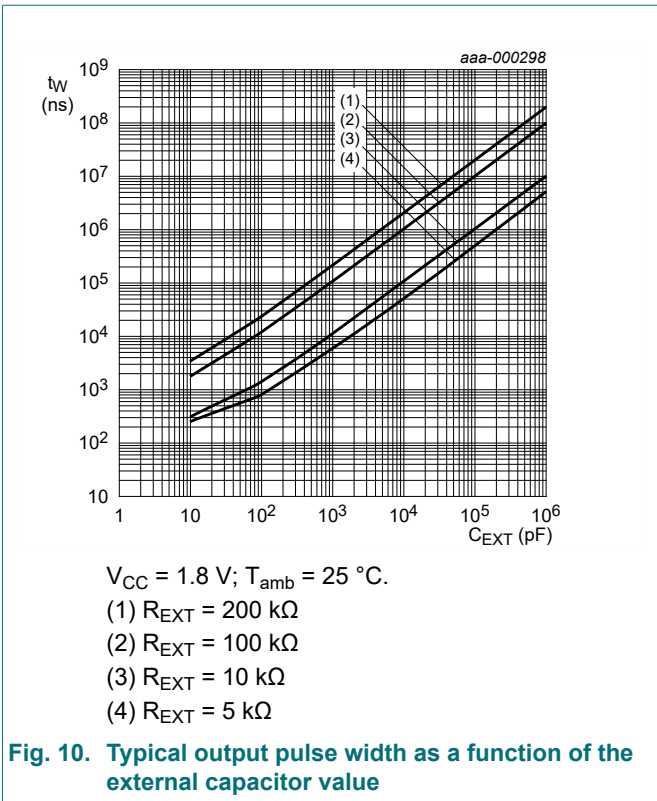

Fig. 10. Typical output pulse width as a function of the external capacitor value

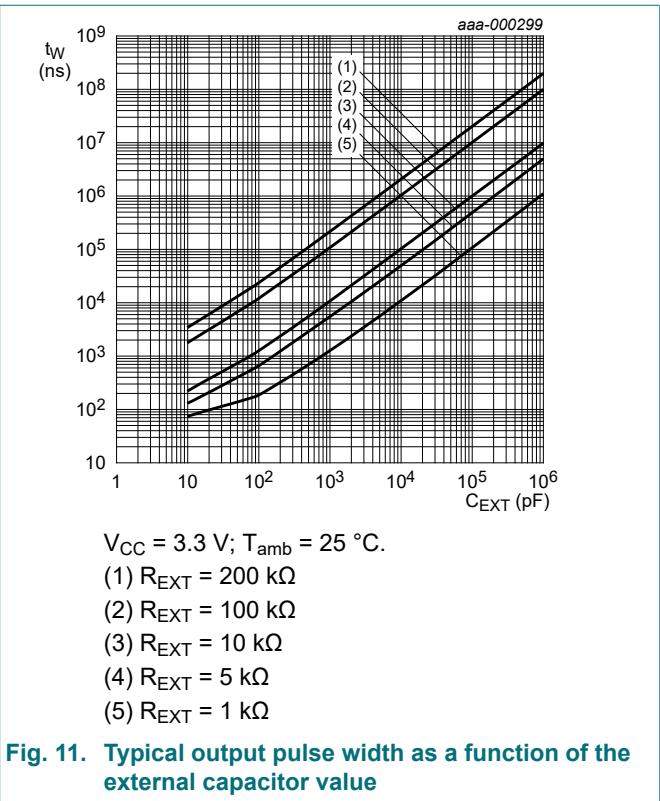
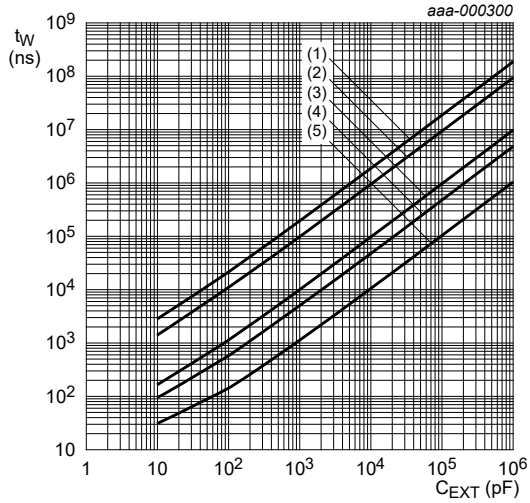

Fig. 11. Typical output pulse width as a function of the external capacitor value

Single retriggerable monostable multivibrator; Schmitt trigger inputs



$V_{CC} = 5.0 \text{ V}; T_{amb} = 25 \text{ }^\circ\text{C}.$

- (1) $R_{EXT} = 200 \text{ k}\Omega$
- (2) $R_{EXT} = 100 \text{ k}\Omega$
- (3) $R_{EXT} = 10 \text{ k}\Omega$
- (4) $R_{EXT} = 5 \text{ k}\Omega$
- (5) $R_{EXT} = 1 \text{ k}\Omega$

Fig. 12. Typical output pulse width as a function of the external capacitor value

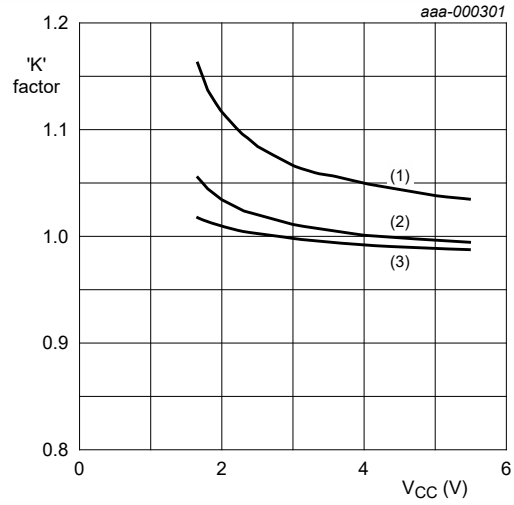

$R_{EXT} = 10 \text{ k}\Omega; T_{amb} = 25 \text{ }^\circ\text{C}.$

- (1) $C_{EXT} = 1000 \text{ pF}$
- (2) $C_{EXT} = 0.01 \text{ }\mu\text{F}$
- (3) $C_{EXT} = 0.1 \text{ }\mu\text{F}$

Fig. 13. Typical 'K' factor as function of V_{CC}

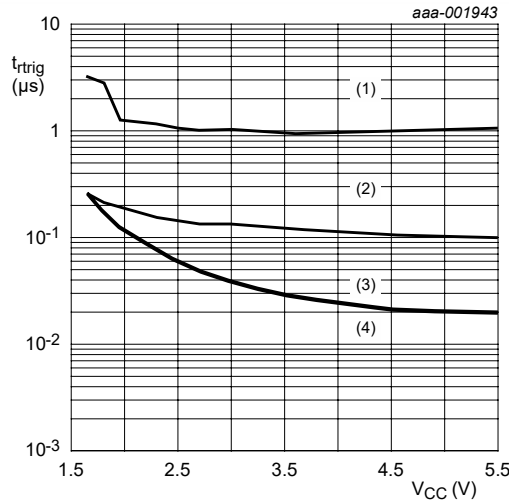

$T_{amb} = 25 \text{ }^\circ\text{C}.$

- (1) $C_{EXT} = 0.01 \text{ }\mu\text{F}$
- (2) $C_{EXT} = 1000 \text{ pF}$
- (3) $C_{EXT} = 100 \text{ pF}$
- (4) $C_{EXT} = 10 \text{ pF}$

Fig. 14. Minimum retrigger time as function of the supply voltage

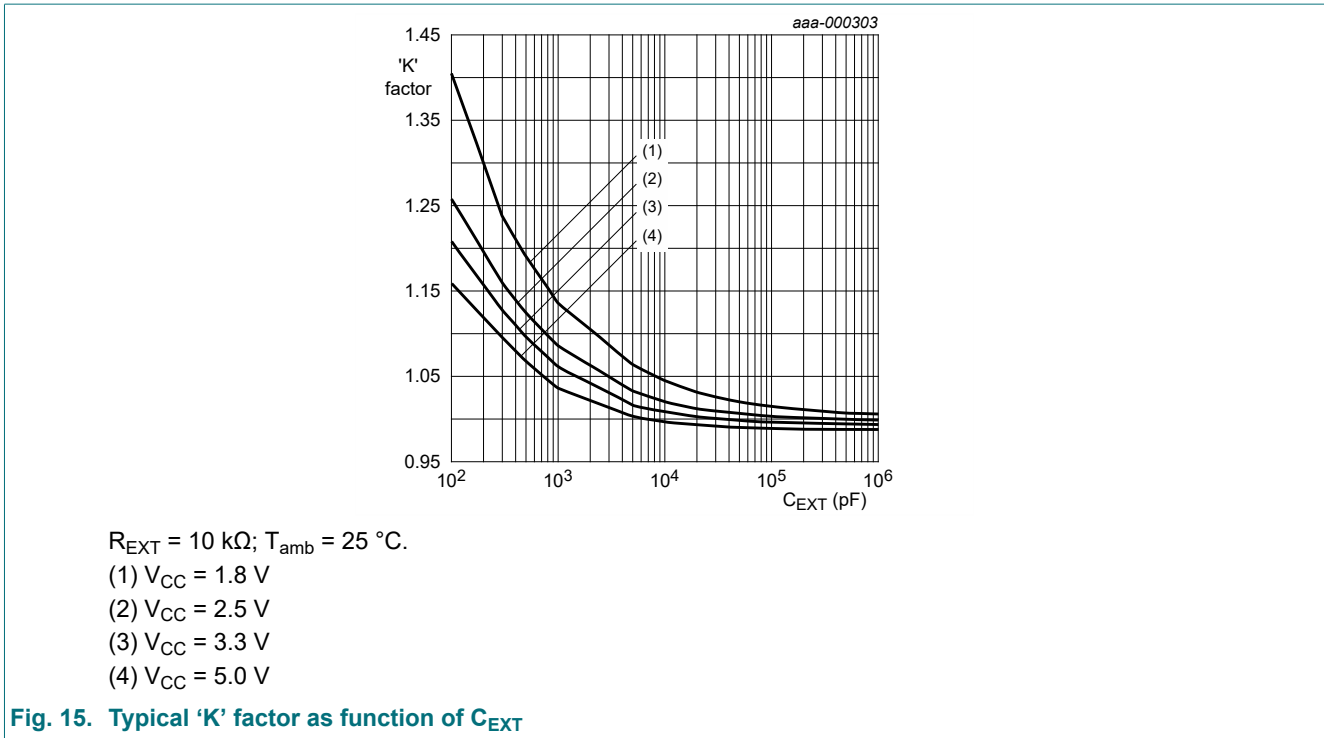

Single retriggerable monostable multivibrator; Schmitt trigger inputs

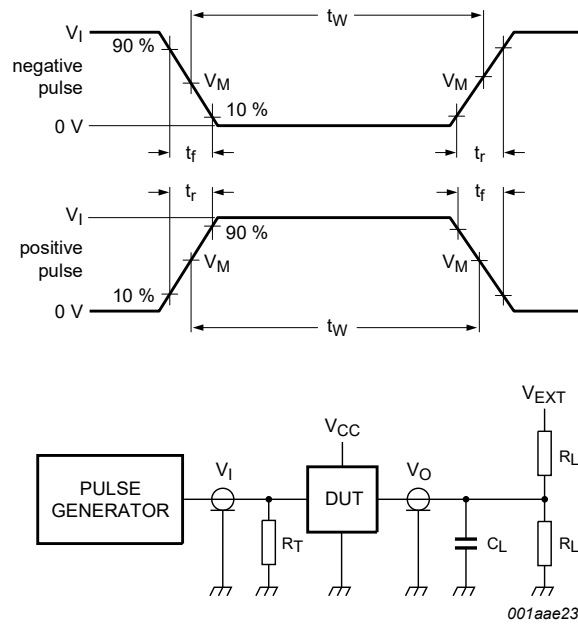

Test data is given in [Table 11](#).

Definitions for test circuit:

R_L = Load resistance.

C_L = Load capacitance including jig and probe capacitance.

R_T = Termination resistance should be equal to output impedance Z_o of the pulse generator.

V_{EXT} = Test voltage for switching times.

Fig. 16. Test circuit for measuring switching times

Table 11. Test data

Supply voltage	Input		Load		V_{EXT}
V_{CC}	V_I	t_r, t_f	C_L	R_L	t_{PLH}, t_{PHL}
1.65 V to 1.95 V	V_{CC}	≤ 2.0 ns	15 pF	1 M Ω	open
2.3 V to 2.7 V	V_{CC}	≤ 2.0 ns	15 pF	1 M Ω	open
2.7 V	2.7 V	≤ 2.5 ns	15 pF	1 M Ω	open
3.0 V to 3.6 V	2.7 V	≤ 2.5 ns	15 pF	1 M Ω	open
4.5 V to 5.5 V	V_{CC}	≤ 2.5 ns	15 pF	1 M Ω	open
1.65 V to 1.95 V	V_{CC}	≤ 2.0 ns	30 pF	1 k Ω	open
2.3 V to 2.7 V	V_{CC}	≤ 2.0 ns	30 pF	500 Ω	open
2.7 V	2.7 V	≤ 2.5 ns	50 pF	500 Ω	open
3.0 V to 3.6 V	2.7 V	≤ 2.5 ns	50 pF	500 Ω	open
4.5 V to 5.5 V	V_{CC}	≤ 2.5 ns	50 pF	500 Ω	open

12. Package outline

TSSOP8: plastic thin shrink small outline package; 8 leads; body width 3 mm; lead length 0.5 mm SOT505-2

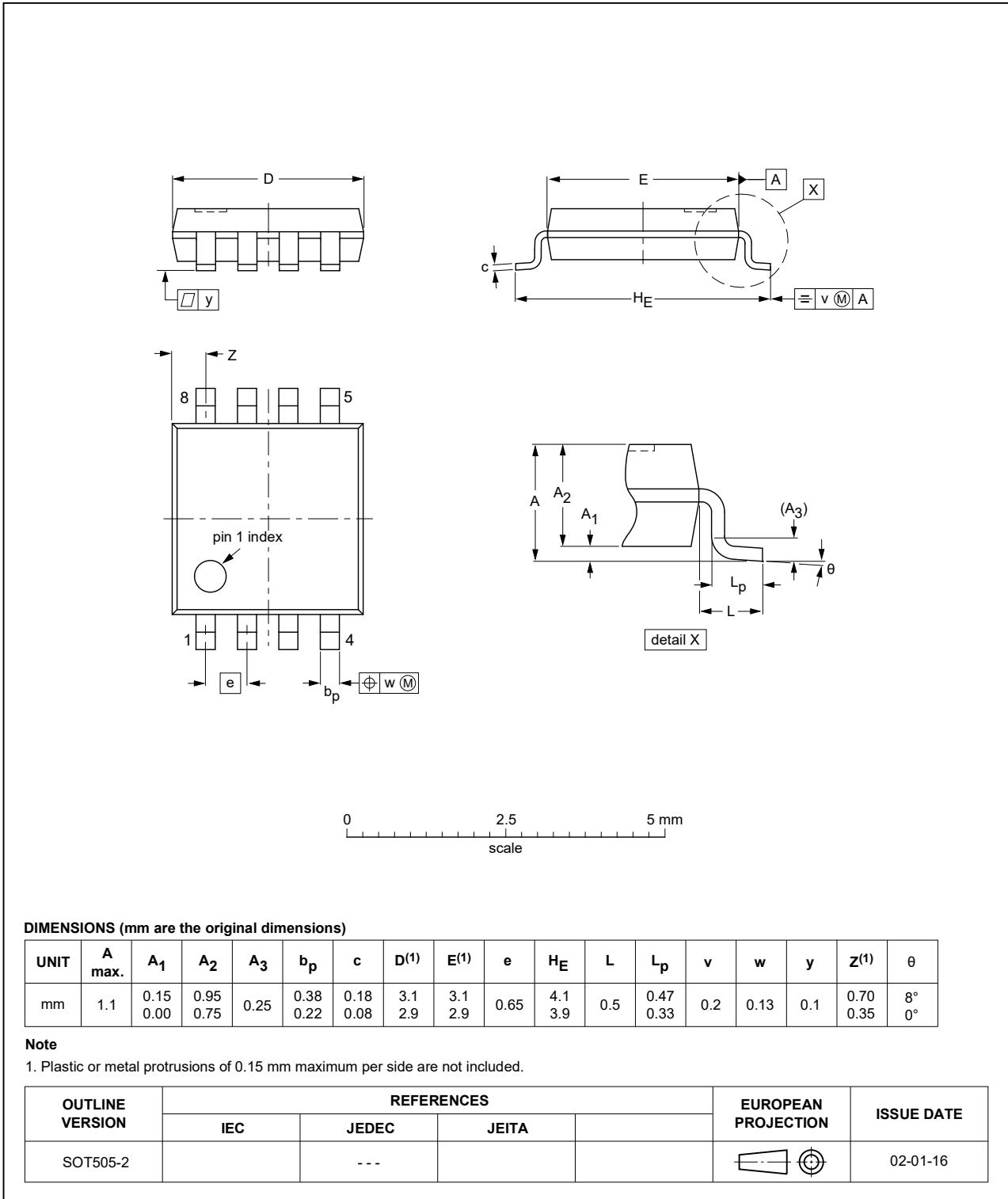

Fig. 17. Package outline SOT505-2 (TSSOP8)

VSSOP8: plastic very thin shrink small outline package; 8 leads; body width 2.3 mm

SOT765-1

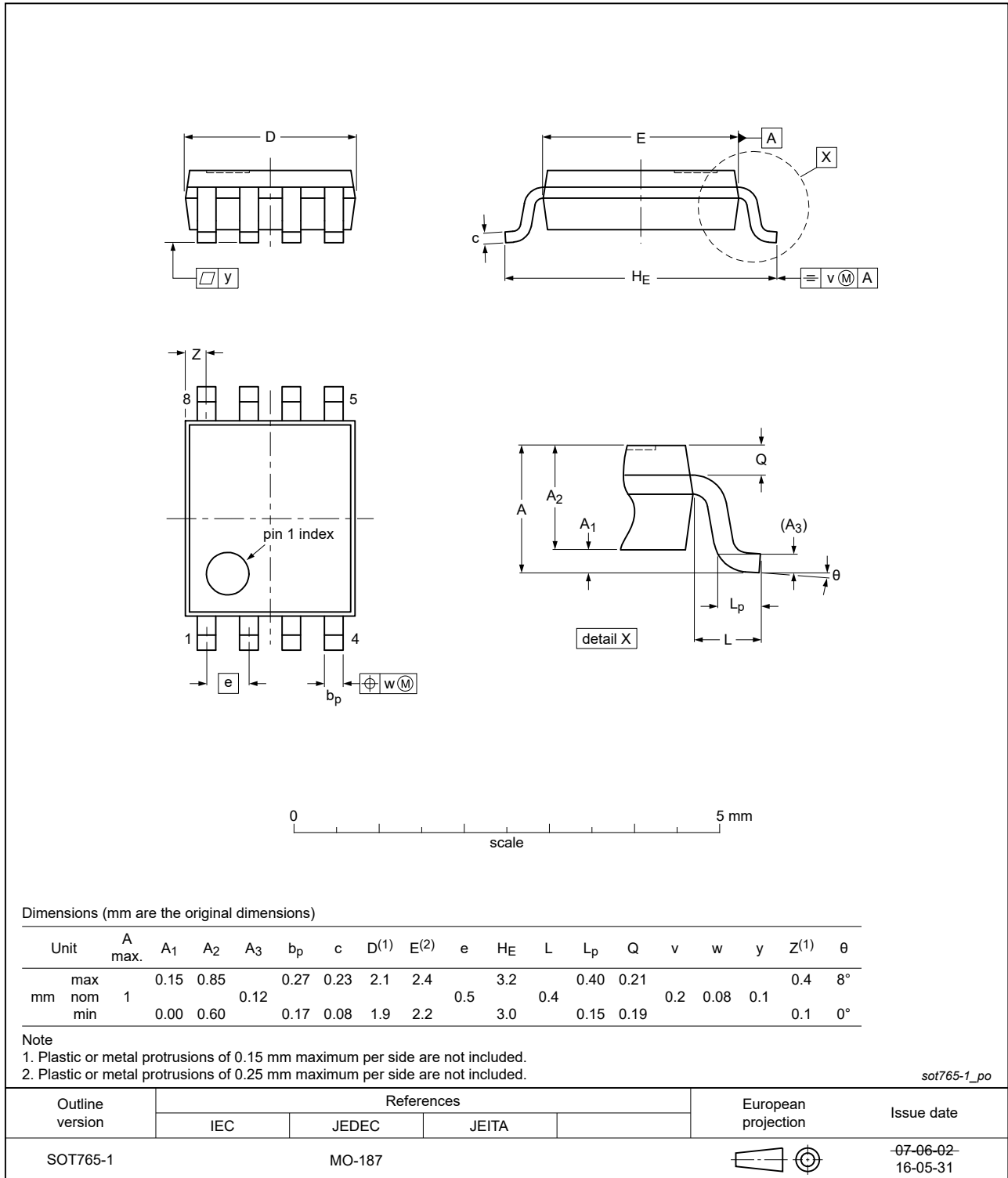

Fig. 18. Package outline SOT765-1 (VSSOP8)

13. Abbreviations

Table 12. Abbreviations

Acronym	Description
CDM	Charged Device Model
CMOS	Complementary Metal-Oxide Semiconductor
DUT	Device Under Test
ESD	ElectroStatic Discharge
HBM	Human Body Model
TTL	Transistor-Transistor Logic

14. Revision history

Table 13. Revision history

Document ID	Release date	Data sheet status	Change notice	Supersedes
74LVC1G123_Q100 v.5	20230814	Product data sheet	-	74LVC1G123_Q100 v.4
Modifications:	<ul style="list-style-type: none"> Section 2: ESD specification updated according to the latest JEDEC standard. 			
74LVC1G123_Q100 v.4	20210420	Product data sheet	-	74LVC1G123_Q100 v.3
Modifications:	<ul style="list-style-type: none"> Section 8: Derating values for P_{tot} total power dissipation have been updated. 			
74LVC1G123_Q100 v.3	20181102	Product data sheet	-	74LVC1G123_Q100 v.2
Modifications:	<ul style="list-style-type: none"> The format of this data sheet has been redesigned to comply with the identity guidelines of Nexperia. Legal texts have been adapted to the new company name where appropriate. 			
74LVC1G123_Q100 v.2	20160613	Product data sheet	-	74LVC1G123_Q100 v.1
Modifications:	<ul style="list-style-type: none"> Fig. 18, package outline drawing for SOT765-1 has changed 			
74LVC1G123_Q100 v.1	20140310	Product data sheet	-	-

15. Legal information

Data sheet status

Document status [1][2]	Product status [3]	Definition
Objective [short] data sheet	Development	This document contains data from the objective specification for product development.
Preliminary [short] data sheet	Qualification	This document contains data from the preliminary specification.
Product [short] data sheet	Production	This document contains the product specification.

- [1] Please consult the most recently issued document before initiating or completing a design.
- [2] The term 'short data sheet' is explained in section "Definitions".
- [3] The product status of device(s) described in this document may have changed since this document was published and may differ in case of multiple devices. The latest product status information is available on the internet at <https://www.nexperia.com>.

Definitions

Draft — The document is a draft version only. The content is still under internal review and subject to formal approval, which may result in modifications or additions. Nexperia does not give any representations or warranties as to the accuracy or completeness of information included herein and shall have no liability for the consequences of use of such information.

Short data sheet — A short data sheet is an extract from a full data sheet with the same product type number(s) and title. A short data sheet is intended for quick reference only and should not be relied upon to contain detailed and full information. For detailed and full information see the relevant full data sheet, which is available on request via the local Nexperia sales office. In case of any inconsistency or conflict with the short data sheet, the full data sheet shall prevail.

Product specification — The information and data provided in a Product data sheet shall define the specification of the product as agreed between Nexperia and its customer, unless Nexperia and customer have explicitly agreed otherwise in writing. In no event however, shall an agreement be valid in which the Nexperia product is deemed to offer functions and qualities beyond those described in the Product data sheet.

Disclaimers

Limited warranty and liability — Information in this document is believed to be accurate and reliable. However, Nexperia does not give any representations or warranties, expressed or implied, as to the accuracy or completeness of such information and shall have no liability for the consequences of use of such information. Nexperia takes no responsibility for the content in this document if provided by an information source outside of Nexperia.

In no event shall Nexperia be liable for any indirect, incidental, punitive, special or consequential damages (including - without limitation - lost profits, lost savings, business interruption, costs related to the removal or replacement of any products or rework charges) whether or not such damages are based on tort (including negligence), warranty, breach of contract or any other legal theory.

Notwithstanding any damages that customer might incur for any reason whatsoever, Nexperia's aggregate and cumulative liability towards customer for the products described herein shall be limited in accordance with the Terms and conditions of commercial sale of Nexperia.

Right to make changes — Nexperia reserves the right to make changes to information published in this document, including without limitation specifications and product descriptions, at any time and without notice. This document supersedes and replaces all information supplied prior to the publication hereof.

Suitability for use in automotive applications — This Nexperia product has been qualified for use in automotive applications. Unless otherwise agreed in writing, the product is not designed, authorized or warranted to be suitable for use in life support, life-critical or safety-critical systems or

equipment, nor in applications where failure or malfunction of an Nexperia product can reasonably be expected to result in personal injury, death or severe property or environmental damage. Nexperia and its suppliers accept no liability for inclusion and/or use of Nexperia products in such equipment or applications and therefore such inclusion and/or use is at the customer's own risk.

Quick reference data — The Quick reference data is an extract of the product data given in the Limiting values and Characteristics sections of this document, and as such is not complete, exhaustive or legally binding.

Applications — Applications that are described herein for any of these products are for illustrative purposes only. Nexperia makes no representation or warranty that such applications will be suitable for the specified use without further testing or modification.

Customers are responsible for the design and operation of their applications and products using Nexperia products, and Nexperia accepts no liability for any assistance with applications or customer product design. It is customer's sole responsibility to determine whether the Nexperia product is suitable and fit for the customer's applications and products planned, as well as for the planned application and use of customer's third party customer(s). Customers should provide appropriate design and operating safeguards to minimize the risks associated with their applications and products.

Nexperia does not accept any liability related to any default, damage, costs or problem which is based on any weakness or default in the customer's applications or products, or the application or use by customer's third party customer(s). Customer is responsible for doing all necessary testing for the customer's applications and products using Nexperia products in order to avoid a default of the applications and the products or of the application or use by customer's third party customer(s). Nexperia does not accept any liability in this respect.

Limiting values — Stress above one or more limiting values (as defined in the Absolute Maximum Ratings System of IEC 60134) will cause permanent damage to the device. Limiting values are stress ratings only and (proper) operation of the device at these or any other conditions above those given in the Recommended operating conditions section (if present) or the Characteristics sections of this document is not warranted. Constant or repeated exposure to limiting values will permanently and irreversibly affect the quality and reliability of the device.

Terms and conditions of commercial sale — Nexperia products are sold subject to the general terms and conditions of commercial sale, as published at <http://www.nexperia.com/profile/terms>, unless otherwise agreed in a valid written individual agreement. In case an individual agreement is concluded only the terms and conditions of the respective agreement shall apply. Nexperia hereby expressly objects to applying the customer's general terms and conditions with regard to the purchase of Nexperia products by customer.

No offer to sell or license — Nothing in this document may be interpreted or construed as an offer to sell products that is open for acceptance or the grant, conveyance or implication of any license under any copyrights, patents or other industrial or intellectual property rights.

Export control — This document as well as the item(s) described herein may be subject to export control regulations. Export might require a prior authorization from competent authorities.

Translations — A non-English (translated) version of a document is for reference only. The English version shall prevail in case of any discrepancy between the translated and English versions.

Trademarks

Notice: All referenced brands, product names, service names and trademarks are the property of their respective owners.

Contents



1. General description	1
2. Features and benefits	1
3. Ordering information	2
4. Marking	2
5. Functional diagram	2
6. Pinning information	3
6.1. Pinning.....	3
6.2. Pin description.....	4
7. Functional description	4
8. Limiting values	4
9. Recommended operating conditions	5
10. Static characteristics	5
10.1. Waveform transfer characteristics.....	7
11. Dynamic characteristics	8
11.1. Waveforms, graphs and test circuit.....	11
12. Package outline	17
13. Abbreviations	19
14. Revision history	19
15. Legal information	20

© Nexperia B.V. 2023. All rights reserved

For more information, please visit: <http://www.nexperia.com>
For sales office addresses, please send an email to: salesaddresses@nexperia.com
Date of release: 14 August 2023

Looking for pricing, stock, or lifecycle information?

Click below to explore more details on WIN SOURCE:

-  [View 74LVC1G123DP-Q100H on WIN SOURCE](#)
-  [Nexperia USA Inc. Information](#)

Optimize Your Supply Chain with WIN SOURCE Solutions

-  Global Sourcing Solution
-  Obsolete Management
-  Cost Control Management
-  Shortage Management
-  Alternative Solution
-  Excess Inventory Management