



# EZ-USB® NX2LP-Flex™ Flexible USB NAND Flash Controller

## CY7C68033/CY7C68034 Silicon Features

- Certified compliant for bus- or self-powered USB 2.0 operation (TID# 40490118)
  - Single-chip, integrated USB 2.0 transceiver and smart SIE
  - Ultra low power – 43 mA typical current draw in any mode
  - Enhanced 8051 core
    - Firmware runs from internal RAM that is downloaded from NAND Flash at startup
    - No external EEPROM required
  - 15 KBytes of on-chip code/data RAM
    - Default NAND firmware – 8 kB
    - Default free space – 7 kB
  - Four programmable bulk/interrupt/isochronous endpoints
    - Buffering options: double, triple, and quad
  - Additional programmable (bulk/interrupt) 64-byte endpoint
  - SmartMedia standard hardware ECC generation with 1-bit correction and 2-bit detection
  - General programmable interface (GPIF)
    - Enables direct connection to most parallel interfaces
    - Programmable waveform descriptors and configuration registers to define waveforms
    - Supports multiple ready (RDY) inputs and control (CTL) outputs
  - 12 fully programmable general purpose I/O (GPIO) pins
- Integrated, industry-standard enhanced 8051
    - 48-MHz, 24-MHz, or 12-MHz CPU operation
    - Four clocks for each instruction cycle
    - Three counter/timers
    - Expanded interrupt system
    - Two data pointers
  - 3.3-V operation with 5 V tolerant inputs
  - Vectored USB interrupts and GPIF/FIFO interrupts
  - Separate data buffers for the setup and data portions of a control transfer
  - Integrated I<sup>2</sup>C controller, runs at 100 or 400 kHz
  - Four integrated FIFOs
    - Integrated glue logic and FIFOs lower system cost
    - Automatic conversion to and from 16-bit buses
    - Master or slave operation
    - Uses external clock or asynchronous strobes
    - Easy interface to ASIC and DSP ICs
  - Available in space saving 56-pin QFN package

### CY7C68034 Only Silicon Features

- Ideal for battery powered applications
  - Suspend current: 100 μA (typ)

### CY7C68033 Only Silicon Features

- Ideal for non-battery powered applications
  - Suspend current: 300 μA (typ)

## Logic Block Diagram

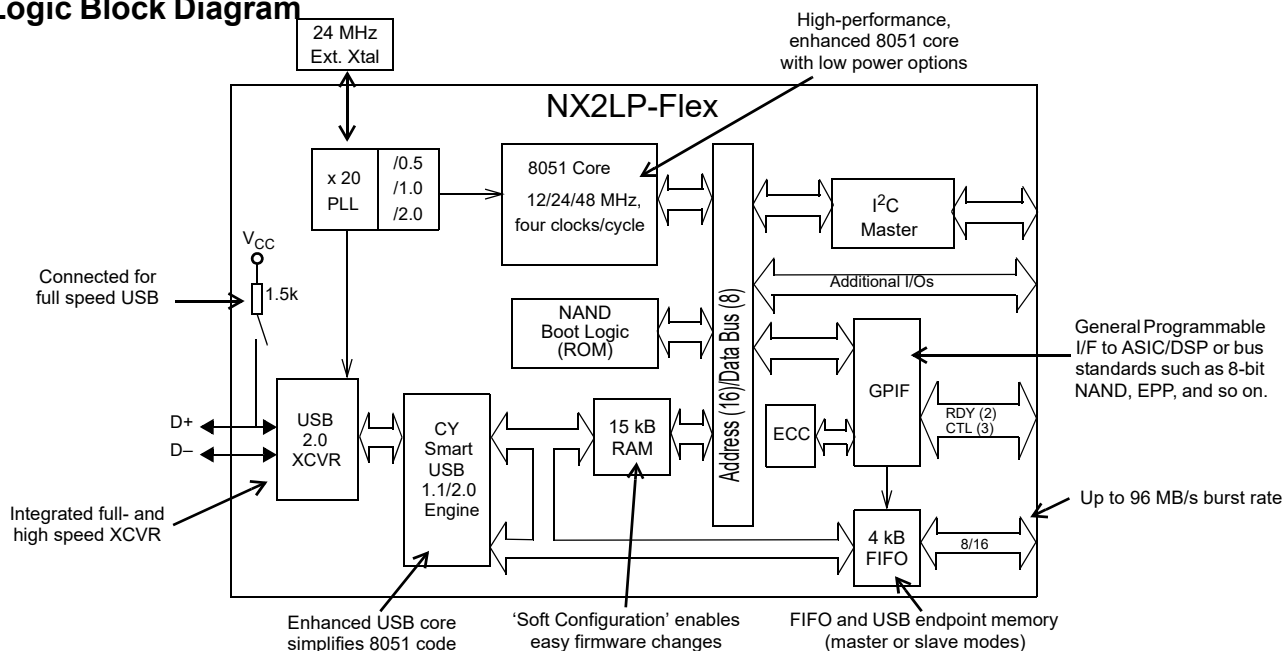

## Default NAND Firmware Features

Because the NX2LP-Flex<sup>®</sup> is intended for NAND Flash-based USB mass storage applications, a default firmware image is included in the development kit with the following features:

- High-Speed (480 Mbps) or Full-Speed (12 Mbps) USB support
- NAND sizes supported per chip select
  - 512 bytes for up to 1 Gb capacity
  - 2K bytes for up to 8 Gb capacity
  - 4K bytes for up to 16 Gb capacity
- 12 configurable GPIO pins
  - Two dedicated chip enable (CE#) pins
  - Six configurable CE#/GPIO pins
    - Up to eight NAND Flash single-device (single-die) chips are supported
    - Up to four NAND Flash dual-device (dual-die) chips are supported
    - Compile option enables unused CE# pins to be configured as GPIOs
  - Four dedicated GPIO pins
- Industry-standard ECC NAND flash correction
  - 1-bit error correction for every 256 bytes
  - 2-bit error detection for every 256 bytes

- Industry standard (SmartMedia) page management for wear leveling algorithm, bad block handling, and physical to logical management.
- 8-bit NAND Flash interface support
- Support for 30 ns, 50 ns, and 100 ns NAND Flash timing
- Complies with the USB mass storage class specification revision 1.0

The default firmware image implements a USB 2.0 NAND Flash controller. This controller adheres to the *Mass Storage Class Bulk-Only Transport Specification*. The USB port of the NX2LP-Flex is connected to a host computer directly or through the downstream port of a USB hub. The host software issues commands and data to the NX2LP-Flex and receives status and data from the NX2LP-Flex using standard USB protocol.

The default firmware image supports industry leading 8-bit NAND Flash interfaces and both common NAND page sizes of 512 and 2k bytes. Up to eight CE# pins enable the NX2LP-Flex to be connected to up to eight single or four dual-die NAND Flash chips.

Complete source code and documentation for the default firmware image are included in the [NX2LP-Flex development kit](#) to enable customization for meeting design requirements. Additionally, compile options for the default firmware enable quick configuration of some features to decrease design effort and increase time-to-market advantages.

## Functional Description

Cypress Semiconductor Corporation's EZ-USB® NX2LP-Flex (CY7C68033/CY7C68034) is a firmware-based, programmable version of the EZ-USB NX2LP (CY7C68023/CY7C68024), which is a fixed-function, low power USB 2.0 NAND Flash controller. By integrating the USB 2.0 transceiver, serial interface engine (SIE), enhanced 8051 microcontroller, and a programmable peripheral interface in a single chip, Cypress has created a very cost-effective solution that enables feature-rich NAND Flash-based applications.

The ingenious architecture of NX2LP-Flex results in USB data transfer rates of over 53 Mbytes per second, the maximum allowable USB 2.0 bandwidth, while still using a low cost 8051 microcontroller in a small 56-pin QFN package. Because it incorporates the USB 2.0 transceiver, the NX2LP-Flex is more economical, providing a smaller footprint solution than external USB 2.0 SIE or transceiver implementations. With EZ-USB NX2LP-Flex, the Cypress Smart SIE handles most of the USB 1.1 and 2.0 protocol, freeing the embedded microcontroller for application-specific functions and decreasing development time while ensuring USB compatibility.

The GPIF and master/slave endpoint FIFO (8- or 16-bit data bus) provide an easy and glueless interface to popular interfaces such as UTOPIA, EPP, I<sup>2</sup>C, PCMCIA, and most DSP processors.

## Applications

The NX2LP-Flex enables designers to add extra functionality to basic NAND Flash mass storage designs, or to interface them with other peripheral devices. Applications may include:

- NAND Flash-based GPS devices
- NAND Flash-based DVB video capture devices
- Wireless pointer/presenter tools with NAND Flash storage
- NAND Flash-based MPEG/TV conversion devices
- Legacy conversion devices with NAND Flash storage
- NAND Flash-based cameras
- NAND Flash mass storage device with biometric (for example, fingerprint) security
- Home PNA devices with NAND Flash storage

- Wireless LAN with NAND Flash storage
- NAND Flash-based MP3 players
- LAN networking with NAND Flash storage

**Figure 1. Example DVB Block Diagram**

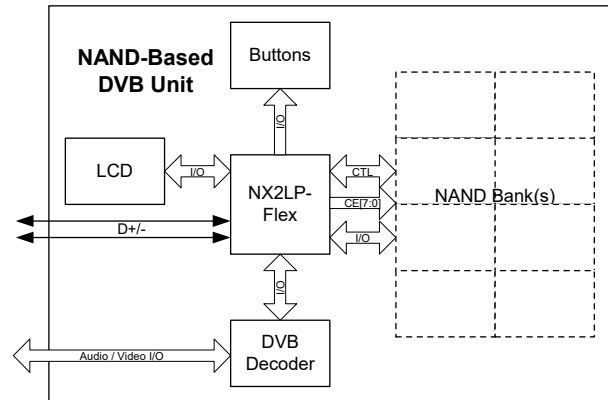

**Figure 2. Example GPS Block Diagram**

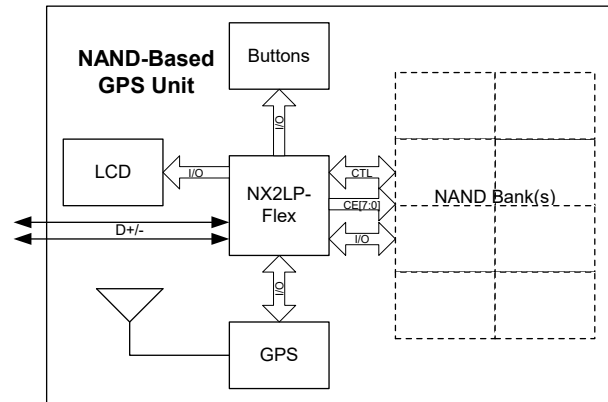

The "Reference Designs" section of the Cypress web site provides additional tools for typical USB 2.0 applications. Each reference design comes complete with firmware source and object code, schematics, and documentation.

## Contents

<b>Functional Overview</b> .....	<b>5</b>	<b>AC Electrical Characteristics</b> .....	<b>29</b>
USB Signaling Speed .....	5	USB Transceiver .....	29
8051 Microprocessor .....	5	Slave FIFO Asynchronous Read .....	29
I2C Bus .....	5	Slave FIFO Asynchronous Write .....	29
Buses .....	6	Slave FIFO Asynchronous Packet End Strobe .....	30
Enumeration .....	6	Slave FIFO Output Enable .....	30
Default Silicon ID Values .....	6	Slave FIFO Address to Flags/Data .....	31
ReNumeration™ .....	6	Slave FIFO Asynchronous Address .....	31
Bus-powered Applications .....	6	Sequence Diagram .....	32
Interrupt System .....	6	<b>Ordering Information</b> .....	<b>34</b>
Reset and Wakeup .....	9	Ordering Code Definitions .....	34
Program/Data RAM .....	10	<b>Package Diagrams</b> .....	<b>35</b>
Register Addresses .....	10	<b>PCB Layout Recommendations</b> .....	<b>36</b>
Endpoint RAM .....	11	<b>Quad Flat Package No Leads (QFN) Package</b>	
External FIFO Interface .....	13	<b>Design Notes</b> .....	<b>36</b>
GPIF .....	13	<b>Acronyms</b> .....	<b>38</b>
ECC Generation <sup>[5]</sup> .....	14	<b>Document Conventions</b> .....	<b>38</b>
Autopointer Access .....	14	Units of Measure .....	38
I2C Controller .....	14	<b>Document History Page</b> .....	<b>39</b>
<b>Pin Assignments</b> .....	<b>15</b>	<b>Sales, Solutions, and Legal Information</b> .....	<b>41</b>
<b>Register Summary</b> .....	<b>21</b>	Worldwide Sales and Design Support .....	41
<b>Absolute Maximum Ratings</b> .....	<b>28</b>	Products .....	41
<b>Operating Conditions</b> .....	<b>28</b>	PSoC® Solutions .....	41
<b>DC Electrical Characteristics</b> .....	<b>28</b>	Cypress Developer Community .....	41
USB Transceiver .....	28	Technical Support .....	41

## Functional Overview

### USB Signaling Speed

NX2LP-Flex operates at two of the three rates defined in the USB Specification Revision 2.0, dated April 27, 2000:

- Full speed, with a signaling bit rate of 12 Mbps
- High speed, with a signaling bit rate of 480 Mbps.

NX2LP-Flex does not support the low speed signaling mode of 1.5 Mbps.

### 8051 Microprocessor

The 8051 microprocessor embedded in the NX2LP-Flex has 256 bytes of register RAM, an expanded interrupt system and three timer/counters.

#### 8051 Clock Frequency

NX2LP-Flex has an on-chip oscillator circuit that uses an external 24 MHz ( $\pm 100$  ppm) crystal with the following characteristics:

- Parallel resonant
- Fundamental mode
- 500  $\mu$ W drive level
- 12 pF (5% tolerance) load capacitors.

An on-chip PLL multiplies the 24-MHz oscillator up to 480 MHz, as required by the transceiver/PHY, and internal counters divide it down for use as the 8051 clock. The default 8051 clock frequency is 12 MHz. The clock frequency of the 8051 can be changed by the 8051 through the CPUCS register, dynamically

**Figure 3. Crystal Configuration**

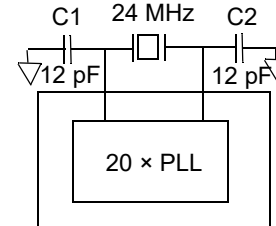

12-pF capacitor values assumes a trace capacitance of 3 pF per side on a four-layer FR4 PCA

#### Special Function Registers

Certain 8051 SFR addresses are populated to provide fast access to critical NX2LP-Flex functions. These SFR additions are shown in [Table 1](#). Bold type indicates non-standard, enhanced 8051 registers. The two SFR rows that end with '0' and '8' contain bit-addressable registers. The four I/O ports A–D use the SFR addresses used in the standard 8051 for ports 0–3, which are not implemented in NX2LP-Flex. Because of the faster and more efficient SFR addressing, the NX2LP-Flex I/O ports are not addressable in external RAM space (using the MOVX instruction).

**Table 1. Special Function Registers**

x	8x	9x	Ax	Bx	Cx	Dx	Ex	Fx
0	<b>IOA</b>	<b>IOB</b>	<b>IOC</b>	<b>IOD</b>	SCON1	PSW	ACC	B
1	SP	<b>EXIF</b>	<b>INT2CLR</b>	<b>IOE</b>	SBUF1			
2	DPL0	<b>MPAGE</b>	<b>INT4CLR</b>	<b>OEA</b>				
3	DPH0			<b>OEB</b>				
4	<b>DPL1</b>			<b>OEC</b>				
5	<b>DPH1</b>			<b>OED</b>				
6	<b>DPS</b>			<b>OEE</b>				
7	PCON							
8	TCON	SCON0	IE	IP	T2CON	<b>EICON</b>	<b>EIE</b>	<b>EIP</b>
9	TMOD	SBUF0						
A	TL0	<b>AUTOPTRH1</b>	<b>EP2468STAT</b>	<b>EP01STAT</b>	RCAP2L			
B	TL1	<b>AUTOPTRL1</b>	<b>EP24FIFOFLGS</b>	<b>GPIFTRIG</b>	RCAP2H			
C	TH0	<b>RESERVED</b>	<b>EP68FIFOFLGS</b>		TL2			
D	TH1	<b>AUTOPTRH2</b>		<b>GPIFSGLDATH</b>	TH2			
E	<b>CKCON</b>	<b>AUTOPTRL2</b>		<b>GPIFSGLDATLX</b>				
F		<b>RESERVED</b>	<b>AUTOPTRSETUP</b>	<b>GPIFSGLDATLNOX</b>				

### I<sup>2</sup>C Bus

NX2LP supports the I<sup>2</sup>C bus as a master only at 100/400 kHz. SCL and SDA pins have open-drain outputs and hysteresis

inputs. These signals must be pulled up to 3.3 V, even if no I<sup>2</sup>C device is connected. The I<sup>2</sup>C bus is disabled at startup and only available for use after the initial NAND access.

## Buses

The NX2LP-Flex features an 8- or 16-bit 'FIFO' bidirectional data bus, multiplexed on I/O ports B and D.

The default firmware image implements an 8-bit data bus in GPIF master mode. It is recommended that additional interfaces added to the default firmware image use this 8-bit data bus.

## Enumeration

During the startup sequence, internal logic checks for the presence of NAND Flash with valid firmware. If valid firmware is found, the NX2LP-Flex loads it and operates according to the firmware. If no NAND Flash is detected, or if no valid firmware is found, the NX2LP-Flex uses the default values from internal ROM space for manufacturing mode operation. The two modes of operation are described in the section [Normal Operation Mode](#) and [Manufacturing Mode](#).

**Figure 4. NX2LP-Flex Enumeration Sequence**

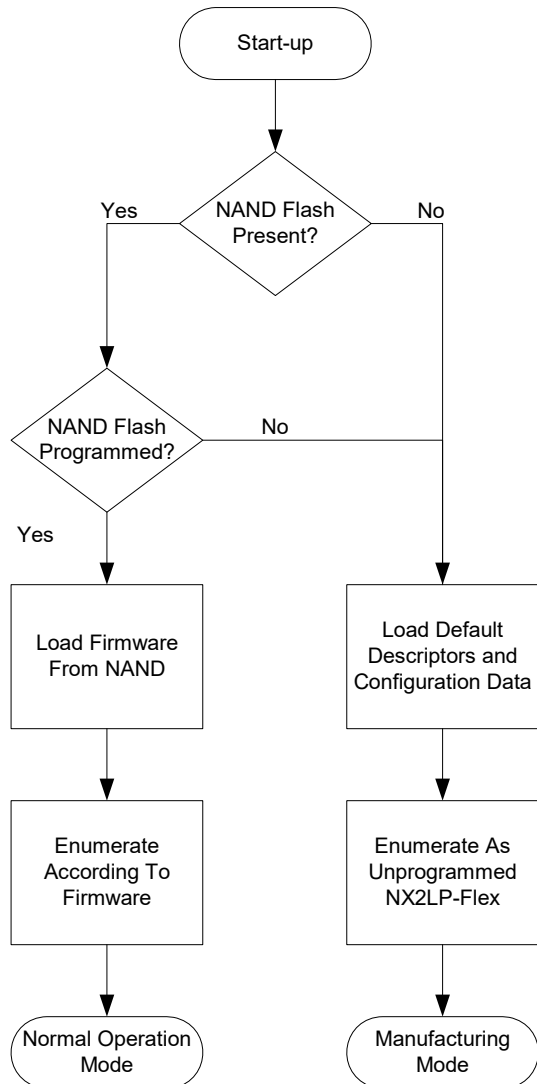

### Normal Operation Mode

In normal operation mode, the NX2LP-Flex behaves as a USB 2.0 Mass Storage Class NAND Flash controller. This includes all typical USB device states (powered, configured, and so on). The USB descriptors are returned according to the data stored in the configuration data memory area. Normal read and write access to the NAND Flash is available in this mode.

### Manufacturing Mode

In manufacturing mode, the NX2LP-Flex enumerates using the default descriptors and configuration data that are stored in internal ROM space. This mode enables for first time programming of the configuration data memory area, and board level manufacturing tests.

### Default Silicon ID Values

To facilitate proper USB enumeration when no programmed NAND Flash is present, the NX2LP-Flex has default silicon ID values stored in ROM space. The default silicon ID values should only be used for development purposes. Designers must use their own Vendor ID for final products. A Vendor ID is obtained through registration with the USB Implementor's Forum (USB-IF). If the NX2LP-Flex is used as a mass storage class device, a unique USB serial number is required for each device to comply with the USB Mass Storage class specification.

Cypress provides all the software tools and drivers necessary to properly programme and test the NX2LP-Flex. Refer to the documentation in the development kit for more information on these topics.

**Table 2. Default Silicon ID Values**

Default VID/PID/DID		
Vendor ID	0x04B4	Cypress Semiconductor
Product ID	0x8613	EZ-USB® Default
Device release	0xAxxx	Depends on chip revision (xxx = chip revision, where first silicon = 001)

### ReEnumeration™

Cypress's ReEnumeration feature is used in conjunction with the NX2LP-Flex manufacturing software tools to enable first-time NAND programming. It is only available when used in conjunction with the NX2LP-Flex manufacturing tools, and is not enabled during normal operation.

### Bus-powered Applications

The NX2LP-Flex fully supports bus-powered designs by enumerating with less than 100 mA, as required by the USB 2.0 specification.

### Interrupt System

#### INT2 Interrupt Request and Enable Registers

NX2LP-Flex implements an autovector feature for INT2 and INT4. There are 27 INT2 (USB) vectors and 14 INT4 (FIFO/GPIF) vectors. For more details, refer to the [EZ-USB Technical Reference Manual \(TRM\)](#).

### USB-Interrupt Autovectors

The main USB interrupt is shared by 27 interrupt sources. To save the code and processing time normally required to identify the individual USB interrupt source, the NX2LP-Flex provides a second level of interrupt vectoring, called Autovectoring. When a USB interrupt is asserted, the NX2LP-Flex pushes the program counter to its stack and then jumps to address 0x0500; it expects

to find a 'jump' instruction to the USB Interrupt service routine here.

Developers familiar with Cypress's programmable USB devices should note that these interrupt vector values differ from those used in other EZ-USB microcontrollers. This is due to the additional NAND boot logic that is present in the NX2LP-Flex ROM space. Also, these values are fixed and cannot be changed in the firmware.

**Table 3. INT2 USB Interrupts**

USB Interrupt Table For INT2			
Priority	INT2VEC Value	Source	Notes
1	0x500	SUDAV	Setup data available
2	0x504	SOF	Start of frame (or microframe)
3	0x508	SUTOK	Setup token received
4	0x50C	SUSPEND	USB suspend request
5	0x510	USB RESET	Bus reset
6	0x514	HISPEED	Entered high speed operation
7	0x518	EP0ACK	NX2LP ACK'd the CONTROL handshake
8	0x51C		Reserved
9	0x520	EP0-IN	EP0-IN ready to be loaded with data
10	0x524	EP0-OUT	EP0-OUT has USB data
11	0x528	EP1-IN	EP1-IN ready to be loaded with data
12	0x52C	EP1-OUT	EP1-OUT has USB data
13	0x530	EP2	IN: buffer available. OUT: buffer has data
14	0x534	EP4	IN: buffer available. OUT: buffer has data
15	0x538	EP6	IN: buffer available. OUT: buffer has data
16	0x53C	EP8	IN: buffer available. OUT: buffer has data
17	0x540	IBN	IN-Bulk-NAK (any IN endpoint)
18	0x544		Reserved
19	0x548	EP0PING	EP0 OUT was pinged and it NAK'd
20	0x54C	EP1PING	EP1 OUT was pinged and it NAK'd
21	0x550	EP2PING	EP2 OUT was pinged and it NAK'd
22	0x554	EP4PING	EP4 OUT was pinged and it NAK'd
23	0x558	EP6PING	EP6 OUT was pinged and it NAK'd
24	0x55C	EP8PING	EP8 OUT was pinged and it NAK'd
25	0x560	ERRLIMIT	Bus errors exceeded the programmed limit
26	0x564		Reserved
27	0x568		Reserved
28	0x56C		Reserved
29	0x570	EP2ISOERR	ISO EP2 OUT PID sequence error
30	0x574	EP4ISOERR	ISO EP4 OUT PID sequence error
31	0x578	EP6ISOERR	ISO EP6 OUT PID sequence error
32	0x57C	EP8ISOERR	ISO EP8 OUT PID sequence error

If autovectoring is enabled (AV2EN = 1 in the INTSET-UP register), the NX2LP-Flex substitutes its INT2VEC byte. Therefore, if the high byte ('page') of a jump-table address is preloaded at location 0x544, the automatically inserted INT2VEC byte at 0x545 directs the jump to the correct address out of the 27 addresses within the page.

#### FIFO/GPIF Interrupt (INT4)

Just as the USB Interrupt is shared among 27 individual USB-interrupt sources, the FIFO/GPIF interrupt is shared among 14 individual FIFO/GPIF sources. The FIFO/GPIF Interrupt, such as the USB Interrupt, can employ autovectoring. Table 4 shows the priority and INT4VEC values for the 14 FIFO/GPIF interrupt sources.

**Table 4. Individual FIFO/GPIF Interrupt Sources**

Priority	INT4VEC Value	Source	Notes
1	0x580	EP2PF	Endpoint 2 programmable flag
2	0x584	EP4PF	Endpoint 4 programmable flag
3	0x588	EP6PF	Endpoint 6 programmable flag
4	0x58C	EP8PF	Endpoint 8 programmable flag
5	0x590	EP2EF	Endpoint 2 empty flag
6	0x594	EP4EF	Endpoint 4 empty flag
7	0x598	EP6EF	Endpoint 6 empty flag
8	0x59C	EP8EF	Endpoint 8 empty flag
9	0x5A0	EP2FF	Endpoint 2 full flag
10	0x5A4	EP4FF	Endpoint 4 full flag
11	0x5A8	EP6FF	Endpoint 6 full flag
12	0x5AC	EP8FF	Endpoint 8 full flag
13	0x5B0	GPIFDONE	GPIF operation complete
14	0x5B4	GPIFWF	GPIF waveform

If autovectoring is enabled (AV4EN = 1 in the INTSET-UP register), the NX2LP-Flex substitutes its INT4VEC byte. Therefore, if the high byte ('page') of a jump-table address is preloaded at location 0x554, the automatically inserted INT4VEC byte at 0x555 directs the jump to the correct address

out of the 14 addresses within the page. When the ISR occurs, the NX2LP-Flex pushes the program counter to its stack and then jumps to address 0x553; it expects to find a 'jump' instruction to the ISR Interrupt service routine here.

## Reset and Wakeup

### Reset Pin

The input pin RESET#, resets the NX2LP-Flex when asserted. This pin has hysteresis and is active LOW. When a crystal is used as the clock source for the NX2LP-Flex, the reset period must enable the stabilization of the crystal and the PLL. This reset period should be approximately 5 ms after V<sub>CC</sub> has reached 3.0V. If the crystal input pin is driven by a clock signal,

the internal PLL stabilizes in 200 μs after V<sub>CC</sub> has reached 3.0 V<sup>[1]</sup>. Figure 5 shows a POR condition and a reset applied during operation. A POR is defined as the time reset is asserted while power is being applied to the circuit. A powered reset is defined to be when the NX2LP-Flex has previously been powered on and operating and the RESET# pin is asserted.

For more information on power on reset implementation for the EZ-USB family of products, refer to the application note [Guide to a Successful EZ-USB® FX2LP™ Hardware Design](#).

**Figure 5. Reset Timing Plots**

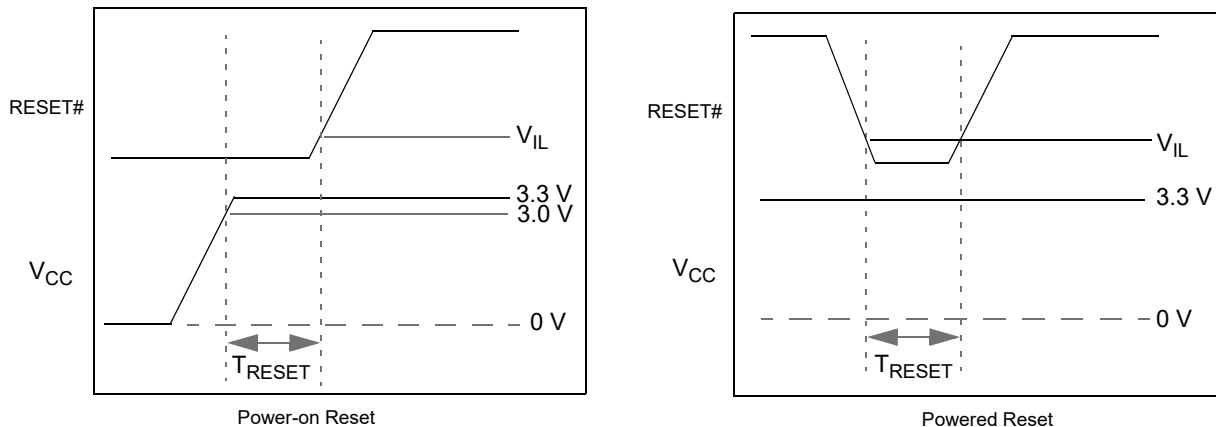

**Table 5. Reset Timing Values**

Condition	T <sub>RESET</sub>
Power-on reset with crystal	5 ms
Power-on reset with external clock source	200 μs + Clock stability time
Powered reset	200 μs

### Wakeup Pins

The 8051 puts itself and the rest of the chip into a power down mode by setting PCON.0 = 1. This stops the oscillator and PLL. When WAKEUP is asserted by external logic, the oscillator restarts, after the PLL stabilizes, and then the 8051 receives a

wakeup interrupt. This applies whether or not NX2LP-Flex is connected to the USB.

The NX2LP-Flex exits the power down (USB suspend) state using one of the following methods:

- USB bus activity (if D+/D- lines are left floating, noise on these lines may indicate activity to the NX2LP-Flex and initiate a wakeup).
- External logic asserts the WAKEUP pin
- External logic asserts the PA3/WU2 pin.

The second wakeup pin, WU2, can also be configured as a GPIO pin. This enables a simple external R-C network to be used as a periodic wakeup source. Note that WAKEUP is, by default, active LOW.

### Note

1. If the external clock is powered at the same time as the CY7C68033/CY7C68034 and has a stabilization wait period, it must be added to the 200 μs.

### Program/Data RAM

#### Internal ROM/RAM Size

The NX2LP-Flex has 1 kBytes ROM and 15 kBytes of internal program/data RAM, where PSEN#/RD# signals are internally ORed to enable the 8051 to access it as both program and data memory. No USB control registers appear in this space.

#### Internal Code Memory

This mode implements the internal block of RAM (starting at 0x0500) as combined code and data memory, as shown in Figure 6.

Only the internal and scratch pad RAM spaces have the following access:

- USB download (only supported by the Cypress manufacturing tool)
- Setup data pointer
- NAND boot access.

**Figure 6. Internal Code Memory**

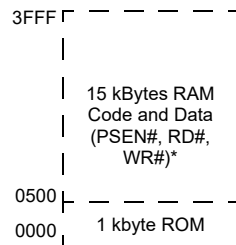
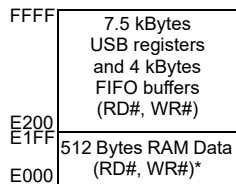

\*SUDPTR, USB download, NAND boot access

### Register Addresses

**Figure 7. Internal Register Addresses**

FFFF	4 KBytes EP2-EP8 buffers (8 × 512)
F000	
EFFF	2 KBytes RESERVED
E800	
E7FF	
E7C0	64 Bytes EP1IN
E7BF	
E780	64 Bytes EP1OUT
E77F	
E740	64 Bytes EP0 IN/OUT
E73F	
E700	64 Bytes RESERVED
E6FF	
	8051 Addressable Registers (512)
E500	
E4FF	Reserved (128)
E480	
E47F	
E400	128 bytes GPIF Waveforms
E3FF	
E200	Reserved (512)
E1FF	
	512 bytes 8051 xdata RAM
E000	

**Endpoint RAM**

*Size*

- 3 × 64 bytes (Endpoints 0 and 1)
- 8 × 512 bytes (Endpoints 2, 4, 6, 8)

*Organization*

- EP0
  - Bidirectional endpoint zero, 64-byte buffer
- EP1IN, EP1OUT
  - 64-byte buffers, bulk or interrupt
- EP2, 4, 6, 8
  - Eight 512-byte buffers, bulk, interrupt, or isochronous.
  - EP4 and EP8 can be double buffered, while EP2 and 6 can be either double, triple, or quad buffered.

For high speed endpoint configuration options, see [Figure 8](#).

*Setup Data Buffer*

A separate 8-byte buffer at 0xE6B8-0xE6BF holds the setup data from a CONTROL transfer.

*Endpoint Configurations (High Speed Mode)*

Endpoints 0 and 1 are the same for every configuration. Endpoint 0 is the only control endpoint, and endpoint 1 can be either bulk or interrupt. The endpoint buffers can be configured in any 1 of the 12 configurations shown in the vertical columns. When operating in full speed bulk mode, only the first 64 bytes of each buffer are used. For example, in high speed the max packet size is 512 bytes, but in full speed it is 64 bytes. Even though a buffer is configured to be a 512 byte buffer, in full speed only the first 64 bytes are used. The unused endpoint buffer space is not available for other operations. The following is an example endpoint configuration:

EP2–1024 double buffered; EP6–512 quad buffered (column 8 in [Figure 8](#)).

**Figure 8. Endpoint Configuration**

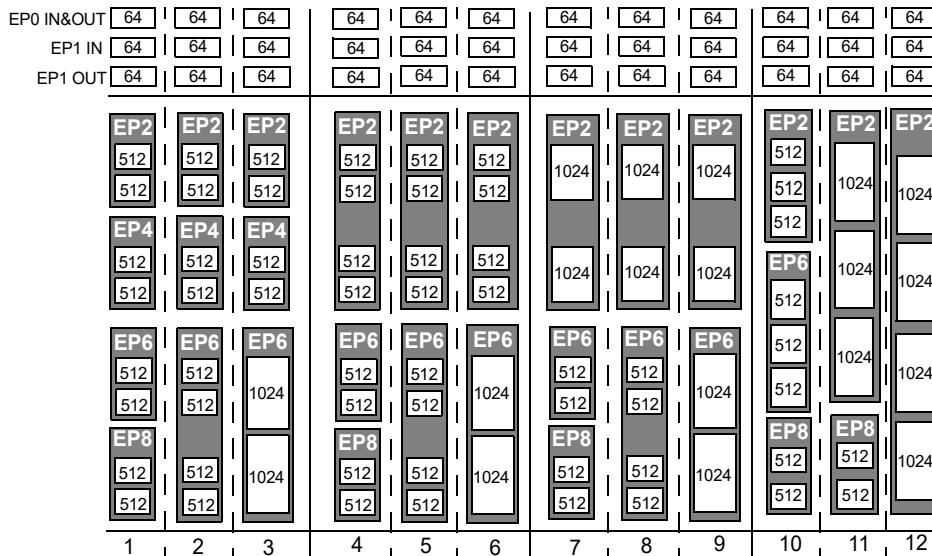

*Default Full Speed Alternate Settings*
**Table 6. Default Full Speed Alternate Settings** <sup>[2, 3]</sup>

Alternate Setting	0	1	2	3
ep0	64	64	64	64
ep1out	0	64 bulk	64 int	64 int
ep1in	0	64 bulk	64 int	64 int
ep2	0	64 bulk out (2×)	64 int out (2×)	64 iso out (2×)
ep4	0	64 bulk out (2×)	64 bulk out (2×)	64 bulk out (2×)
ep6	0	64 bulk in (2×)	64 int in (2×)	64 iso in (2×)
ep8	0	64 bulk in (2×)	64 bulk in (2×)	64 bulk in (2×)

*Default High Speed Alternate Settings*
**Table 7. Default High Speed Alternate Settings** <sup>[2, 3]</sup>

Alternate Setting	0	1	2	3
ep0	64	64	64	64
ep1out	0	512 bulk <sup>[4]</sup>	64 int	64 int
ep1in	0	512 bulk <sup>[4]</sup>	64 int	64 int
ep2	0	512 bulk out (2×)	512 int out (2×)	512 iso out (2×)
ep4	0	512 bulk out (2×)	512 bulk out (2×)	512 bulk out (2×)
ep6	0	512 bulk in (2×)	512 int in (2×)	512 iso in (2×)
ep8	0	512 bulk in (2×)	512 bulk in (2×)	512 bulk in (2×)

**Notes**

2. '0' means 'not implemented.'
3. '2×' means 'double buffered.'
4. Even though these buffers are 64 bytes, they are reported as 512 for USB 2.0 compliance. The user must never transfer packets larger than 64 bytes to EP1.

## External FIFO Interface

### Architecture

The NX2LP-Flex slave FIFO architecture has eight 512-byte blocks in the endpoint RAM that directly serve as FIFO memories, and are controlled by FIFO control signals (such as SLCS#, SLRD, SLWR, SLOE, PKTEND, and flags).

In operation, some of the eight RAM blocks fill or empty from the SIE, while the others are connected to the I/O transfer logic. The transfer logic takes two forms: the GPIF for internally generated control signals or the slave FIFO interface for externally controlled transfers.

### Master/Slave Control Signals

The NX2LP-Flex endpoint FIFOS are implemented as eight physically distinct  $256 \times 16$  RAM blocks. The 8051/SIE can switch any of the RAM blocks between two domains, the USB (SIE) domain and the 8051-I/O Unit domain. This switching is done virtually instantaneously, giving essentially zero transfer time between 'USB FIFOS' and 'Slave FIFOS'. Since they are physically the same memory, no bytes are actually transferred between buffers.

At any time, some RAM blocks are filling/emptying with USB data under SIE control, while other RAM blocks are available to the 8051 and/or the I/O control unit. The RAM blocks operate as single-port in the USB domain and dual-port in the 8051-I/O domain. The blocks can be configured as single, double, triple, or quad buffered as previously shown.

The I/O control unit implements either an internal-master (M for master) or external-master (S for Slave) interface.

In master (M) mode, the GPIF internally controls FIFOADR[1:0] to select a FIFO. The two RDY pins can be used as flag inputs from an external FIFO or other logic if desired. The GPIF can be run from an internally derived clock (IFCLK), at a rate that transfers data up to 96 Megabytes/s (48 MHz IFCLK with 16-bit interface).

In slave (S) mode, the NX2LP-Flex accepts an internally derived clock (IFCLK, max. frequency 48 MHz) and SLCS#, SLRD, SLWR, SLOE, PKTEND signals from external logic. Each endpoint can individually be selected for byte or word operation by an internal configuration bit and a Slave FIFO output enable signal SLOE enables data of the selected width. External logic must ensure that the output enable signal is inactive when writing data to a slave FIFO. The slave interface must operate asynchronously, where the SLRD and SLWR signals act directly as strobes, rather than a clock qualifier as in a synchronous mode. The signals SLRD, SLWR, SLOE and PKTEND are gated by the signal SLCS#.

### GPIF and FIFO Clock Rates

An 8051 register bit selects one of two frequencies for the internally supplied interface clock: 30 MHz and 48 MHz. A bit within the IFCONFIG register inverts the IFCLK signal.

The default NAND firmware image implements a 48 MHz internally supplied interface clock. The NAND boot logic uses the same configuration to implement 100-ns timing on the NAND bus to support proper detection of all NAND Flash types.

## GPIF

The GPIF is a flexible 8- or 16-bit parallel interface driven by a user-programmable finite state machine. It enables the NX2LP-Flex to perform local bus mastering and can implement a wide variety of protocols such as 8-bit NAND interface, printer parallel port, and Utopia. The default NAND firmware and boot logic uses GPIF functionality to interface with NAND Flash.

The GPIF on the NX2LP-Flex features three programmable control outputs (CTL) and two general purpose ready inputs (RDY). The GPIF data bus width can be 8 or 16 bits. Because the default NAND firmware image implements an 8-bit data bus and up to eight chip enable pins on the GPIF ports, it is recommended that designs based upon the default firmware image also use an 8-bit data bus.

Each GPIF vector defines the state of the control outputs and determines what state a ready input (or multiple inputs) must be before proceeding. The GPIF vector can be programmed to advance a FIFO to the next data value, advance an address, and so on. A sequence of the GPIF vectors make up a single waveform that is executed to perform the desired data move between the NX2LP-Flex and the external device.

### Three Control OUT Signals

The NX2LP-Flex exposes three control signals, CTL[2:0]. CTLx waveform edges can be programmed to make transitions as fast as once per clock (20.8 ns using a 48 MHz clock).

### Two Ready IN Signals

The 8051 programs the GPIF unit to test the RDY pins for GPIF branching. The 56-pin package brings out two signals, RDY[1:0].

### Long Transfer Mode

In GPIF master mode, the 8051 appropriately sets GPIF transaction count registers (GPIFTCB3, GPIFTCB2, GPIFTCB1, or GPIFTCB0) for unattended transfers of up to  $2^{32}$  transactions. The GPIF automatically throttles data flow to prevent underflow or overflow until the full number of requested transactions complete. The GPIF decrements the value in these registers to represent the current status of the transaction.

## ECC Generation<sup>[5]</sup>

The NX2LP-Flex can calculate error correcting codes (ECCs) on data that passes across its GPIF or slave FIFO interfaces. There are two ECC configurations:

- Two ECCs, each calculated over 256 bytes (SmartMedia Standard)
- One ECC calculated over 512 bytes.

The following two ECC configurations are selected by the ECCM bit. The ECC can correct any one-bit error or detect any two-bit error.

*ECCM = 0*

Two 3-byte ECCs, each calculated over a 256-byte block of data. This configuration conforms to the SmartMedia Standard and is used by both the NAND boot logic and default NAND firmware image.

When any value is written to ECCRESET and data is then passed across the GPIF or slave FIFO interface, the ECC for the first 256 bytes of data is calculated and stored in ECC1. The ECC for the next 256 bytes of data is stored in ECC2. After the second ECC is calculated, the values in the ECCx registers do not change until ECCRESET is written again, even if more data is subsequently passed across the interface.

*ECCM = 1*

One 3-byte ECC calculated over a 512-byte block of data.

When any value is written to ECCRESET and data is then passed across the GPIF or slave FIFO interface, the ECC for the first 512 bytes of data is calculated and stored in ECC1; ECC2 is unused. After the ECC is calculated, the value in ECC1 does not change until ECCRESET is written again, even if more data is subsequently passed across the interface

## Autopointer Access

NX2LP-Flex provides two identical autopointers. They are similar to the internal 8051 data pointers, but with an additional feature: they can optionally increment after every memory access. Also, the autopointers can point to any NX2LP-Flex register or endpoint buffer space.

## I<sup>2</sup>C Controller

NX2LP has one I<sup>2</sup>C port that the 8051, once running uses to control external I<sup>2</sup>C devices. The I<sup>2</sup>C port operates in master mode only. The I<sup>2</sup>C port is disabled at startup and only available for use after the initial NAND access.

### I<sup>2</sup>C Port Pins

The I<sup>2</sup>C pins SCL and SDA must have external 2.2-kΩ pull up resistors even if no EEPROM is connected to the NX2LP.

### I<sup>2</sup>C Interface General-Purpose Access

The 8051 can control peripherals connected to the I<sup>2</sup>C bus using the I<sup>2</sup>CTL and I<sup>2</sup>DATA registers. NX2LP provides I<sup>2</sup>C master control only and is never an I<sup>2</sup>C slave.

#### Note

5. To use the ECC logic, the GPIF or Slave FIFO interface must be configured for byte-wide operation.

## Pin Assignments

Figure 9 and Figure 10 on page 16 identify all signals for the 56-pin NX2LP-Flex package.

Three modes of operation are available for the NX2LP-Flex: Port mode, GPIF Master mode, and Slave FIFO mode. These modes define the signals on the right edge of each column in Figure 9. The right-most column details the signal functionality from the

default NAND firmware image, which actually utilizes GPIF Master mode. The signals on the left edge of the 'Port' column are common to all modes of the NX2LP-Flex. The 8051 selects the interface mode using the IFCONFIG[1:0] register bits. Port mode is the power-on default configuration.

Figure 10 on page 16 details the pinout of the 56-pin package and lists pin names for all modes of operation. Pin names with an asterisk (\*) feature programmable polarity.

Figure 9. Port and Signal Mapping

	Port	GPIF Master	Slave FIFO	Default NAND Firmware Use
		PD7 ↔ FD[15]	↔ FD[15]	↔ CE7#/GPIO7
		PD6 ↔ FD[14]	↔ FD[14]	↔ CE6#/GPIO6
		PD5 ↔ FD[13]	↔ FD[13]	↔ CE5#/GPIO5
		PD4 ↔ FD[12]	↔ FD[12]	↔ CE4#/GPIO4
		PD3 ↔ FD[11]	↔ FD[11]	↔ CE3#/GPIO3
		PD2 ↔ FD[10]	↔ FD[10]	↔ CE2#/GPIO2
		PD1 ↔ FD[9]	↔ FD[9]	↔ CE1#
		PD0 ↔ FD[8]	↔ FD[8]	↔ CE0#
		PB7 ↔ FD[7]	↔ FD[7]	↔ DD7
		PB6 ↔ FD[6]	↔ FD[6]	↔ DD6
		PB5 ↔ FD[5]	↔ FD[5]	↔ DD5
		PB4 ↔ FD[4]	↔ FD[4]	↔ DD4
		PB3 ↔ FD[3]	↔ FD[3]	↔ DD3
		PB2 ↔ FD[2]	↔ FD[2]	↔ DD2
		PB1 ↔ FD[1]	↔ FD[1]	↔ DD1
		PB0 ↔ FD[0]	↔ FD[0]	↔ DD0
		← RDY0	← SLRD	← R_B1#
		← RDY1	← SLWR	← R_B2#
		→ CTL0	→ FLAGA	→ WE#
		→ CTL1	→ FLAGB	→ RE0#
		→ CTL2	→ FLAGC	→ RE1#
		PA7 ↔ PA7	↔ FLAGD/SLCS#/PA7	↔ GPIO1
		PA6 ↔ PA6	↔ PKTEND	↔ GPIO0
		PA5 ↔ PA5	← FIFOADR1	← WP_SW#
		PA4 ↔ PA4	← FIFOADR0	← WP_NF#
		↔ PA3/WU2	← PA3/WU2	→ LED2#
		↔ PA2	← SLOE	→ LED1#
		↔ PA1/INT1#	← PA1/INT1#	↔ ALE
		↔ PA0/INT0#	↔ PA0/INT0#	↔ CLE
		PE0 ↔ GPIO8	↔ GPIO8	↔ GPIO8
		PE1 ↔ GPIO9	↔ GPIO9	↔ GPIO9
↔	XTALIN			
↔	XTALOUT			
↔	RESET#			
↔	WAKEUP#			
↔	SCL			
↔	SDATA			
↔	DPLUS			
↔	DMINUS			

Figure 10. CY7C68033/CY7C68034 56-pin QFN Pin Assignment

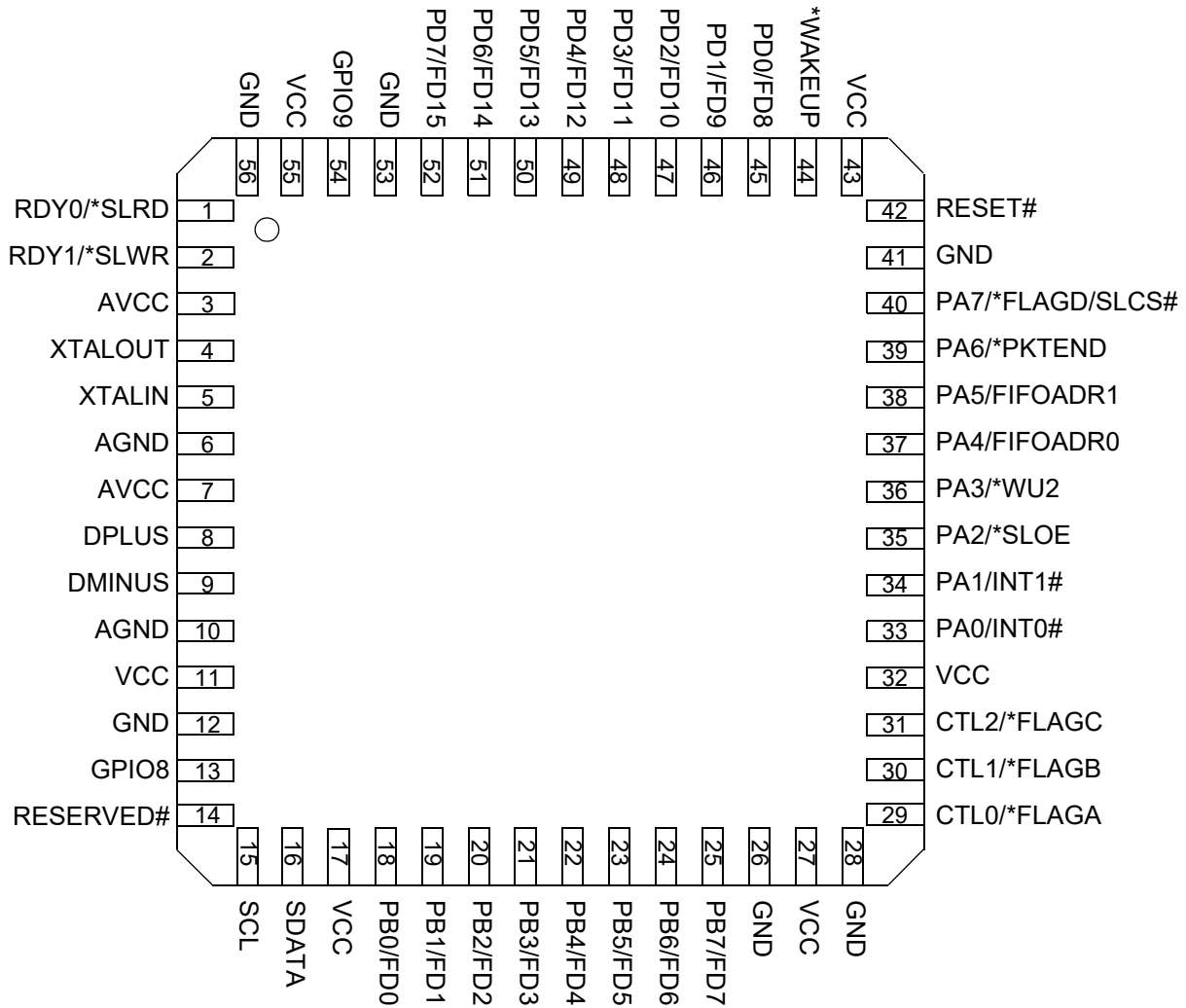

**Table 8. NX2LP-Flex Pin Descriptions** <sup>[6]</sup>

56-pin QFN Pin Number	Default Pin Name	NAND Firmware Usage	Pin Type	Default State	Description
9	DMINUS	N/A	I/O/Z	Z	<b>USB D– Signal.</b> Connect to the USB D– signal.
8	DPLUS	N/A	I/O/Z	Z	<b>USB D+ Signal.</b> Connect to the USB D+ signal.
42	RESET#	N/A	Input	N/A	<b>Active LOW Reset.</b> Resets the entire chip. See section <a href="#">Reset and Wakeup on page 9</a> for more details.
5	XTALIN	N/A	Input	N/A	<b>Crystal Input.</b> Connect this signal to a 24 MHz parallel-resonant, fundamental mode crystal and load capacitor to GND. It is also correct to drive XTALIN with an external 24 MHz square wave derived from another clock source. When driving from an external source, the driving signal should be a 3.3 V square wave.
4	XTALOUT	N/A	Output	N/A	<b>Crystal Output.</b> Connect this signal to a 24 MHz parallel-resonant, fundamental mode crystal and load capacitor to GND. If an external clock is used to drive XTALIN, leave this pin open.
54	PE1 or GPIO9	GPIO9	O/Z	12 MHz	<b>GPIO9</b> is a bidirectional I/O port pin.
1	RDY0 or SLRD	R_B1#	Input	N/A	Multiplexed pin whose function is selected by IFCONFIG[1:0]. <b>RDY0</b> is a GPIF input signal. <b>SLRD</b> is the input-only read strobe with programmable polarity (FIFOPINPOLAR[3]) for the slave FIFOs connected to FD[7:0] or FD[15:0]. <b>R_B1#</b> is a NAND Ready/Busy input signal.
2	RDY1 or SLWR	R_B2#	Input	N/A	Multiplexed pin whose function is selected by IFCONFIG[1:0]. <b>RDY1</b> is a GPIF input signal. <b>SLWR</b> is the input-only write strobe with programmable polarity (FIFOPINPOLAR[2]) for the slave FIFOs connected to FD[7:0] or FD[15:0]. <b>R_B2#</b> is a NAND Ready/Busy input signal.
29	CTL0 or FLAGA	WE#	O/Z	H	Multiplexed pin whose function is selected by IFCONFIG[1:0]. <b>CTL0</b> is a GPIF control output. <b>FLAGA</b> is a programmable slave-FIFO output status flag signal. Defaults to programmable for the FIFO selected by the FIFOADR[1:0] pins. <b>WE#</b> is the NAND write enable output signal.
30	CTL1 or FLAGB	RE0#	O/Z	H	Multiplexed pin whose function is selected by IFCONFIG[1:0]. <b>CTL1</b> is a GPIF control output. <b>FLAGB</b> is a programmable slave-FIFO output status flag signal. Defaults to FULL for the FIFO selected by the FIFOADR[1:0] pins. <b>RE0#</b> is a NAND read enable output signal.
31	CTL2 or FLAGC	RE1#	O/Z	H	Multiplexed pin whose function is selected by IFCONFIG[1:0]. <b>CTL2</b> is a GPIF control output. <b>FLAGC</b> is a programmable slave-FIFO output status flag signal. Defaults to EMPTY for the FIFO selected by the FIFOADR[1:0] pins. <b>RE1#</b> is a NAND read enable output signal.

**Note**

6. Unused inputs should not be left floating. Tie either HIGH or LOW as appropriate. Outputs should only be pulled up or down to ensure signals at power up and in standby. Note also that no pins should be driven while the device is powered down.

Table 8. NX2LP-Flex Pin Descriptions (continued)<sup>[6]</sup>

56-pin QFN Pin Number	Default Pin Name	NAND Firmware Usage	Pin Type	Default State	Description
13	PE0 or GPIO8	GPIO8	I/O/Z	I	<b>GPIO8:</b> is a bidirectional I/O port pin.
14	Reserved#	N/A	Input	N/A	<b>Reserved.</b> Connect to ground.
15	SCL	N/A	OD	Z	Clock for the I <sup>2</sup> C interface. Connect to VCC with a 2.2K resistor, even if no I <sup>2</sup> C peripheral is attached.
16	SDATA	N/A	OD	Z	Data for the I <sup>2</sup> C interface. Connect to VCC with a 2.2K resistor, even if no I <sup>2</sup> C peripheral is attached.
44	WAKEUP	Unused	Input	N/A	<b>USB Wakeup.</b> If the 8051 is in suspend, asserting this pin starts up the oscillator and interrupts the 8051 to allow it to exit the suspend mode. Holding WAKEUP asserted inhibits the EZ-USB chip from suspending. This pin has programmable polarity, controlled by WAKEUP[4].
<b>Port A</b>					
33	PA0 or INT0#	CLE	I/O/Z	I (PA0)	Multiplexed pin whose function is selected by PORTACFG[0] <b>PA0</b> is a bidirectional I/O port pin. <b>INT0#</b> is the active-LOW 8051 INT0 interrupt input signal, which is either edge triggered (IT0 = 1) or level triggered (IT0 = 0). <b>CLE</b> is the NAND Command Latch Enable signal.
34	PA1 or INT1#	ALE	I/O/Z	I (PA1)	Multiplexed pin whose function is selected by PORTACFG[1] <b>PA1</b> is a bidirectional I/O port pin. <b>INT1#</b> is the active-LOW 8051 INT1 interrupt input signal, which is either edge triggered (IT1 = 1) or level triggered (IT1 = 0). <b>ALE</b> is the NAND Address Latch Enable signal.
35	PA2 or SLOE	LED1#	I/O/Z	I (PA2)	Multiplexed pin whose function is selected by IFCONFIG[1:0]. <b>PA2</b> is a bidirectional I/O port pin. <b>SLOE</b> is an input-only output enable with programmable polarity (FIFOPINPOLAR[4]) for the slave FIFOs connected to FD[7:0] or FD[15:0]. <b>LED1#</b> is the data activity indicator LED sink pin.
36	PA3 or WU2	LED2#	I/O/Z	I (PA3)	Multiplexed pin whose function is selected by WAKEUP[7] and OEA[3] <b>PA3</b> is a bidirectional I/O port pin. <b>WU2</b> is an alternate source for <b>USB Wakeup</b> , enabled by WU2EN bit (WAKEUP[1]) and polarity set by WU2POL (WAKEUP[4]). If the 8051 is in suspend and WU2EN = 1, a transition on this pin starts up the oscillator and interrupts the 8051 to allow it to exit the suspend mode. Asserting this pin inhibits the chip from suspending, if WU2EN = 1. <b>LED2#</b> is the chip activity indicator LED sink pin.
37	PA4 or FIFOADR0	WP_NF#	I/O/Z	I (PA4)	Multiplexed pin whose function is selected by IFCONFIG[1:0]. <b>PA4</b> is a bidirectional I/O port pin. <b>FIFOADR0</b> is an input-only address select for the slave FIFOs connected to FD[7:0] or FD[15:0]. <b>WP_NF#</b> is the NAND write-protect control output signal.
38	PA5 or FIFOADR1	WP_SW#	I/O/Z	I (PA5)	Multiplexed pin whose function is selected by IFCONFIG[1:0]. <b>PA5</b> is a bidirectional I/O port pin. <b>FIFOADR1</b> is an input-only address select for the slave FIFOs connected to FD[7:0] or FD[15:0]. <b>WP_SW#</b> is the NAND write-protect switch input signal.

**Table 8. NX2LP-Flex Pin Descriptions** (continued)<sup>[6]</sup>

56-pin QFN Pin Number	Default Pin Name	NAND Firmware Usage	Pin Type	Default State	Description
39	PA6 or PKTEND	GPIO0 (Input)	I/O/Z	I (PA6)	Multiplexed pin whose function is selected by the IFCONFIG[1:0] bits. <b>PA6</b> is a bidirectional I/O port pin. <b>PKTEND</b> is an input used to commit the FIFO packet data to the endpoint and whose polarity is programmable via FIFOPINPOLAR[5]. <b>GPIO1</b> is a general purpose I/O signal.
40	PA7 or FLAGD or SLCS#	GPIO1 (Input)	I/O/Z	I (PA7)	Multiplexed pin whose function is selected by the IFCONFIG[1:0] and PORTACFG[7] bits. <b>PA7</b> is a bidirectional I/O port pin. <b>FLAGD</b> is a programmable slave-FIFO output status flag signal. <b>SLCS#</b> gates all other slave FIFO enable/strobes <b>GPIO0</b> is a general purpose I/O signal.
<b>Port B</b>					
18	PB0 or FD[0]	DD0	I/O/Z	I (PB0)	Multiplexed pin whose function is selected by IFCONFIG[1:0]. <b>PB0</b> is a bidirectional I/O port pin. <b>FD[0]</b> is the bidirectional FIFO/GPIF data bus. <b>DD0</b> is a bidirectional NAND data bus signal.
19	PB1 or FD[1]	DD1	I/O/Z	I (PB1)	Multiplexed pin whose function is selected by IFCONFIG[1:0]. <b>PB1</b> is a bidirectional I/O port pin. <b>FD[1]</b> is the bidirectional FIFO/GPIF data bus. <b>DD1</b> is a bidirectional NAND data bus signal.
20	PB2 or FD[2]	DD2	I/O/Z	I (PB2)	Multiplexed pin whose function is selected by IFCONFIG[1:0]. <b>PB2</b> is a bidirectional I/O port pin. <b>FD[2]</b> is the bidirectional FIFO/GPIF data bus. <b>DD2</b> is a bidirectional NAND data bus signal.
21	PB3 or FD[3]	DD3	I/O/Z	I (PB3)	Multiplexed pin whose function is selected by IFCONFIG[1:0]. <b>PB3</b> is a bidirectional I/O port pin. <b>FD[3]</b> is the bidirectional FIFO/GPIF data bus. <b>DD3</b> is a bidirectional NAND data bus signal.
22	PB4 or FD[4]	DD4	I/O/Z	I (PB4)	Multiplexed pin whose function is selected by IFCONFIG[1:0]. <b>PB4</b> is a bidirectional I/O port pin. <b>FD[4]</b> is the bidirectional FIFO/GPIF data bus. <b>DD4</b> is a bidirectional NAND data bus signal.
23	PB5 or FD[5]	DD5	I/O/Z	I (PB5)	Multiplexed pin whose function is selected by IFCONFIG[1:0]. <b>PB5</b> is a bidirectional I/O port pin. <b>FD[5]</b> is the bidirectional FIFO/GPIF data bus. <b>DD5</b> is a bidirectional NAND data bus signal.
24	PB6 or FD[6]	DD6	I/O/Z	I (PB6)	Multiplexed pin whose function is selected by IFCONFIG[1:0]. <b>PB6</b> is a bidirectional I/O port pin. <b>FD[6]</b> is the bidirectional FIFO/GPIF data bus. <b>DD6</b> is a bidirectional NAND data bus signal.
25	PB7 or FD[7]	DD7	I/O/Z	I (PB7)	Multiplexed pin whose function is selected by IFCONFIG[1:0]. <b>PB7</b> is a bidirectional I/O port pin. <b>FD[7]</b> is the bidirectional FIFO/GPIF data bus. <b>DD7</b> is a bidirectional NAND data bus signal.
<b>PORT D</b>					
45	PD0 or FD[8]	CE0#	I/O/Z	I (PD0)	Multiplexed pin whose function is selected by the IFCONFIG[1:0] and EPxFIFOCFG.0 (wordwide) bits. <b>FD[8]</b> is the bidirectional FIFO/GPIF data bus. <b>CE0#</b> is a NAND chip enable output signal.

Table 8. NX2LP-Flex Pin Descriptions (continued)<sup>[6]</sup>

56-pin QFN Pin Number	Default Pin Name	NAND Firmware Usage	Pin Type	Default State	Description
46	PD1 or FD[9]	CE1#	I/O/Z	I (PD1)	Multiplexed pin whose function is selected by the IFCONFIG[1:0] and EPxFIFOCFG.0 (wordwide) bits. <b>FD[9]</b> is the bidirectional FIFO/GPIF data bus. <b>CE1#</b> is a NAND chip enable output signal.
47	PD2 or FD[10]	CE2# or GPIO2	I/O/Z	I (PD2)	Multiplexed pin whose function is selected by the IFCONFIG[1:0] and EPxFIFOCFG.0 (wordwide) bits. <b>FD[10]</b> is the bidirectional FIFO/GPIF data bus. <b>CE2#</b> is a NAND chip enable output signal. <b>GPIO2</b> is a general purpose I/O signal.
48	PD3 or FD[11]	CE3# or GPIO3	I/O/Z	I (PD3)	Multiplexed pin whose function is selected by the IFCONFIG[1:0] and EPxFIFOCFG.0 (wordwide) bits. <b>FD[11]</b> is the bidirectional FIFO/GPIF data bus. <b>CE3#</b> is a NAND chip enable output signal. <b>GPIO3</b> is a general purpose I/O signal.
49	PD4 or FD[12]	CE4# or GPIO4	I/O/Z	I (PD4)	Multiplexed pin whose function is selected by the IFCONFIG[1:0] and EPxFIFOCFG.0 (wordwide) bits. <b>FD[12]</b> is the bidirectional FIFO/GPIF data bus. <b>CE4#</b> is a NAND chip enable output signal. <b>GPIO4</b> is a general purpose I/O signal.
50	PD5 or FD[13]	CE5# or GPIO5	I/O/Z	I (PD5)	Multiplexed pin whose function is selected by the IFCONFIG[1:0] and EPxFIFOCFG.0 (wordwide) bits. <b>FD[13]</b> is the bidirectional FIFO/GPIF data bus. <b>CE5#</b> is a NAND chip enable output signal. <b>GPIO5</b> is a general purpose I/O signal.
51	PD6 or FD[14]	CE6# or GPIO6	I/O/Z	I (PD6)	Multiplexed pin whose function is selected by the IFCONFIG[1:0] and EPxFIFOCFG.0 (wordwide) bits. <b>FD[14]</b> is the bidirectional FIFO/GPIF data bus. <b>CE6#</b> is a NAND chip enable output signal. <b>GPIO6</b> is a general purpose I/O signal.
52	PD7 or FD[15]	CE7# or GPIO7	I/O/Z	I (PD7)	Multiplexed pin whose function is selected by the IFCONFIG[1:0] and EPxFIFOCFG.0 (wordwide) bits. <b>FD[15]</b> is the bidirectional FIFO/GPIF data bus. <b>CE7#</b> is a NAND chip enable output signal. <b>GPIO7</b> is a general purpose I/O signal.
<b>Power and Ground</b>					
3, 7	AVCC	N/A	Power	N/A	<b>Analog V<sub>CC</sub></b> . Connect this pin to 3.3 V power source. This signal provides power to the analog section of the chip.
6, 10	AGND	N/A	Ground	N/A	<b>Analog Ground</b> . Connect to ground with as short a path as possible.
11, 17, 27, 32, 43, 55	VCC	N/A	Power	N/A	<b>V<sub>CC</sub></b> . Connect to 3.3 V power source.
12, 26, 28, 41, 53, 56	GND	N/A	Ground	N/A	<b>Ground</b> .

## Register Summary

NX2LP-Flex register bit definitions are described in the EZ-USB TRM in greater detail. Some registers that are listed here and in the TRM do not apply to the NX2LP-Flex. They are kept here for consistency reasons only. Registers that do not apply to the NX2LP-Flex should be left at their default power up values.

**Table 9. NX2LP-Flex Register Summary**

Hex	Size	Name	Description	b7	b6	b5	b4	b3	b2	b1	b0	Default	Access
GPIF Waveform Memories													
E400	128	WAVEDATA	GPIF Waveform Descriptor 0, 1, 2, 3 data	D7	D6	D5	D4	D3	D2	D1	D0	xxxxxxx	RW
E480	128	reserved											
GENERAL CONFIGURATION													
E50D		GPCR2	General Purpose Configuration Register 2	reserved	reserved	reserved	FULL_SPEED_ONLY	reserved	reserved	reserved	reserved	00000000	R
E600	1	CPUCS	CPU Control & Status	0	0	PORTCSTB	CLKSPD1	CLKSPD0	CLKINV	CLKOE	8051RES	0000010	rrbbbbb
E601	1	IFCONFIG	Interface Configuration (Ports, GPIF, slave FIFOs)	1	3048 MHz	0	IFCLKPOL	ASYN	GSTATE	IFCFG1	IFCFG0	10000000	RW
E602	1	PINFLAGSSAB <sup>[7]</sup>	Slave FIFO FLAGA and FLAGB Pin Configuration	FLAGB3	FLAGB2	FLAGB1	FLAGB0	FLAGA3	FLAGA2	FLAGA1	FLAGA0	00000000	RW
E603	1	PINFLAGSSCD <sup>[7]</sup>	Slave FIFO FLAGC and FLAGD Pin Configuration	FLAGD3	FLAGD2	FLAGD1	FLAGD0	FLAGC3	FLAGC2	FLAGC1	FLAGC0	00000000	RW
E604	1	FIFORESET <sup>[7]</sup>	Restore FIFOs to default state	NAKALL	0	0	0	EP3	EP2	EP1	EP0	xxxxxxx	W
E605	1	BREAKPT	Breakpoint Control	0	0	0	0	BREAK	BPPULSE	BPEN	0	00000000	rrrrbbb
E606	1	BPADDRH	Breakpoint Address H	A15	A14	A13	A12	A11	A10	A9	A8	xxxxxxx	RW
E607	1	BPADDRL	Breakpoint Address L	A7	A6	A5	A4	A3	A2	A1	A0	xxxxxxx	RW
E608	1	UART230	230 Kbaud internally generated ref. clock	0	0	0	0	0	0	230UART1	230UART0	00000000	rrrrbbb
E609	1	FIFOPINPOLAR <sup>[7]</sup>	Slave FIFO Interface pins polarity	0	0	PKTEND	SLOE	SLRD	SLWR	EF	FF	00000000	rrbbbbb
E60A	1	REVID	Chip Revision	rv7	rv6	rv5	rv4	rv3	rv2	rv1	rv0	RevA 00000001	R
E60B	1	REVCTL <sup>[7]</sup>	Chip Revision Control	0	0	0	0	0	0	dyn_out	enh_pkt	00000000	rrrrbbb
UDMA													
E60C	1	GPIFHOLDAMOUNT	MSTB Hold Time (for UDMA)	0	0	0	0	0	0	HOLDTIME1	HOLDTIME0	00000000	rrrrbbb
	3	reserved											
ENDPOINT CONFIGURATION													
E610	1	EP1OUTCFG	Endpoint 1-OUT Configuration	VALID	0	TYPE1	TYPE0	0	0	0	0	10100000	brbrrrr
E611	1	EP1INCFG	Endpoint 1-IN Configuration	VALID	0	TYPE1	TYPE0	0	0	0	0	10100000	brbrrrr
E612	1	EP2CFG	Endpoint 2 Configuration	VALID	DIR	TYPE1	TYPE0	SIZE	0	BUF1	BUF0	10100010	bbbbbrbb
E613	1	EP4CFG	Endpoint 4 Configuration	VALID	DIR	TYPE1	TYPE0	0	0	0	0	10100000	bbbrrrr
E614	1	EP6CFG	Endpoint 6 Configuration	VALID	DIR	TYPE1	TYPE0	SIZE	0	BUF1	BUF0	11100010	bbbbbrbb
E615	1	EP8CFG	Endpoint 8 Configuration	VALID	DIR	TYPE1	TYPE0	0	0	0	0	11100000	bbbrrrr
	2	reserved											
E618	1	EP2FIFOCFG <sup>[7]</sup>	Endpoint 2/slave FIFO configuration	0	INFM1	OEP1	AUTOOUT	AUTOIN	ZEROLENIN	0	WORDWIDE	00000101	rbbbbrbb
E619	1	EP4FIFOCFG <sup>[7]</sup>	Endpoint 4/slave FIFO configuration	0	INFM1	OEP1	AUTOOUT	AUTOIN	ZEROLENIN	0	WORDWIDE	00000101	rbbbbrbb
E61A	1	EP6FIFOCFG <sup>[7]</sup>	Endpoint 6/slave FIFO configuration	0	INFM1	OEP1	AUTOOUT	AUTOIN	ZEROLENIN	0	WORDWIDE	00000101	rbbbbrbb
E61B	1	EP8FIFOCFG <sup>[7]</sup>	Endpoint 8/slave FIFO configuration	0	INFM1	OEP1	AUTOOUT	AUTOIN	ZEROLENIN	0	WORDWIDE	00000101	rbbbbrbb
E61C	4	reserved											
E620	1	EP2AUTOINLENH <sup>[7]</sup>	Endpoint 2 AUTOIN Packet Length H	0	0	0	0	0	PL10	PL9	PL8	0000010	rrrrbbb
E621	1	EP2AUTOINLENL <sup>[7]</sup>	Endpoint 2 AUTOIN Packet Length L	PL7	PL6	PL5	PL4	PL3	PL2	PL1	PL0	00000000	RW
E622	1	EP4AUTOINLENH <sup>[7]</sup>	Endpoint 4 AUTOIN Packet Length H	0	0	0	0	0	0	PL9	PL8	0000010	rrrrbbb
E623	1	EP4AUTOINLENL <sup>[7]</sup>	Endpoint 4 AUTOIN Packet Length L	PL7	PL6	PL5	PL4	PL3	PL2	PL1	PL0	00000000	RW
E624	1	EP6AUTOINLENH <sup>[7]</sup>	Endpoint 6 AUTOIN Packet Length H	0	0	0	0	0	PL10	PL9	PL8	0000010	rrrrbbb
E625	1	EP6AUTOINLENL <sup>[7]</sup>	Endpoint 6 AUTOIN Packet Length L	PL7	PL6	PL5	PL4	PL3	PL2	PL1	PL0	00000000	RW
E626	1	EP8AUTOINLENH <sup>[7]</sup>	Endpoint 8 AUTOIN Packet Length H	0	0	0	0	0	0	PL9	PL8	0000010	rrrrbbb
E627	1	EP8AUTOINLENL <sup>[7]</sup>	Endpoint 8 AUTOIN Packet Length L	PL7	PL6	PL5	PL4	PL3	PL2	PL1	PL0	00000000	RW
E628	1	ECCCFG	ECC Configuration	0	0	0	0	0	0	0	ECCM	00000000	rrrrrb

**Note**

7. The register can only be reset, it cannot be set.

**Table 9. NX2LP-Flex Register Summary (continued)**

Hex	Size	Name	Description	b7	b6	b5	b4	b3	b2	b1	b0	Default	Access
E629	1	ECCRESET	ECC Reset	x	x	x	x	x	x	x	x	00000000	W
E62A	1	ECC1B0	ECC1 Byte 0 Address	LINE15	LINE14	LINE13	LINE12	LINE11	LINE10	LINE9	LINE8	00000000	R
E62B	1	ECC1B1	ECC1 Byte 1 Address	LINE7	LINE6	LINE5	LINE4	LINE3	LINE2	LINE1	LINE0	00000000	R
E62C	1	ECC1B2	ECC1 Byte 2 Address	COL5	COL4	COL3	COL2	COL1	COL0	LINE17	LINE16	00000000	R
E62D	1	ECC2B0	ECC2 Byte 0 Address	LINE15	LINE14	LINE13	LINE12	LINE11	LINE10	LINE9	LINE8	00000000	R
E62E	1	ECC2B1	ECC2 Byte 1 Address	LINE7	LINE6	LINE5	LINE4	LINE3	LINE2	LINE1	LINE0	00000000	R
E62F	1	ECC2B2	ECC2 Byte 2 Address	COL5	COL4	COL3	COL2	COL1	COL0	0	0	00000000	R
E630	1	EP2FIFOPFH <sup>[8]</sup>	Endpoint 2/slave FIFO Programmable Flag H	DECIS	PKTSTAT	IN:PKTS[2] OUT:PFC12	IN:PKTS[1] OUT:PFC11	IN:PKTS[0] OUT:PFC10	0	PFC9	PFC8	10001000	bbbbrb
E630	1	EP2FIFOPFH <sup>[8]</sup>	Endpoint 2/slave FIFO Programmable Flag H	DECIS	PKTSTAT	OUT:PFC12	OUT:PFC11	OUT:PFC10	0	PFC9	IN:PKTS[2] OUT:PFC8	10001000	bbbbrb
E631	1	EP2FIFOPFL <sup>[8]</sup>	Endpoint 2/slave FIFO Programmable Flag L	PFC7	PFC6	PFC5	PFC4	PFC3	PFC2	PFC1	PFC0	00000000	RW
E631	1	EP2FIFOPFL <sup>[8]</sup>	Endpoint 2/slave FIFO Programmable Flag L	IN:PKTS[1] OUT:PFC7	IN:PKTS[0] OUT:PFC6	PFC5	PFC4	PFC3	PFC2	PFC1	PFC0	00000000	RW
E632	1	EP4FIFOPFH <sup>[8]</sup>	Endpoint 4/slave FIFO Programmable Flag H	DECIS	PKTSTAT	0	IN:PKTS[1] OUT:PFC10	IN:PKTS[0] OUT:PFC9	0	0	PFC8	10001000	bbrbrb
E632	1	EP4FIFOPFH <sup>[8]</sup>	Endpoint 4/slave FIFO Programmable Flag H	DECIS	PKTSTAT	0	OUT:PFC10	OUT:PFC9	0	0	PFC8	10001000	bbrbrb
E633	1	EP4FIFOPFL <sup>[8]</sup>	Endpoint 4/slave FIFO Programmable Flag L	PFC7	PFC6	PFC5	PFC4	PFC3	PFC2	PFC1	PFC0	00000000	RW
E633	1	EP4FIFOPFL <sup>[8]</sup>	Endpoint 4/slave FIFO Programmable Flag L	IN:PKTS[1] OUT:PFC7	IN:PKTS[0] OUT:PFC6	PFC5	PFC4	PFC3	PFC2	PFC1	PFC0	00000000	RW
E634	1	EP6FIFOPFH <sup>[8]</sup>	Endpoint 6/slave FIFO Programmable Flag H	DECIS	PKTSTAT	IN:PKTS[2] OUT:PFC12	IN:PKTS[1] OUT:PFC11	IN:PKTS[0] OUT:PFC10	0	PFC9	PFC8	00001000	bbbbrb
E634	1	EP6FIFOPFH <sup>[8]</sup>	Endpoint 6/slave FIFO Programmable Flag H	DECIS	PKTSTAT	OUT:PFC12	OUT:PFC11	OUT:PFC10	0	PFC9	IN:PKTS[2] OUT:PFC8	00001000	bbbbrb
E635	1	EP6FIFOPFL <sup>[8]</sup>	Endpoint 6/slave FIFO Programmable Flag L	PFC7	PFC6	PFC5	PFC4	PFC3	PFC2	PFC1	PFC0	00000000	RW
E635	1	EP6FIFOPFL <sup>[8]</sup>	Endpoint 6/slave FIFO Programmable Flag L	IN:PKTS[1] OUT:PFC7	IN:PKTS[0] OUT:PFC6	PFC5	PFC4	PFC3	PFC2	PFC1	PFC0	00000000	RW
E636	1	EP8FIFOPFH <sup>[8]</sup>	Endpoint 8/slave FIFO Programmable Flag H	DECIS	PKTSTAT	0	IN:PKTS[1] OUT:PFC10	IN:PKTS[0] OUT:PFC9	0	0	PFC8	00001000	bbrbrb
E636	1	EP8FIFOPFH <sup>[8]</sup>	Endpoint 8/slave FIFO Programmable Flag H	DECIS	PKTSTAT	0	OUT:PFC10	OUT:PFC9	0	0	PFC8	00001000	bbrbrb
E637	1	EP8FIFOPFL <sup>[8]</sup>	Endpoint 8/slave FIFO Programmable Flag L	PFC7	PFC6	PFC5	PFC4	PFC3	PFC2	PFC1	PFC0	00000000	RW
E637	1	EP8FIFOPFL <sup>[8]</sup>	Endpoint 8/slave FIFO Programmable Flag L	IN:PKTS[1] OUT:PFC7	IN:PKTS[0] OUT:PFC6	PFC5	PFC4	PFC3	PFC2	PFC1	PFC0	00000000	RW
	8	reserved											
E640	1	EP2ISOINPKTS	EP2 (if ISO) IN Packets per frame (1-3)	AADJ	0	0	0	0	0	INPPF1	INPPF0	00000001	brrrrb
E641	1	EP4ISOINPKTS	EP4 (if ISO) IN Packets per frame (1-3)	AADJ	0	0	0	0	0	INPPF1	INPPF0	00000001	brrrrr
E642	1	EP6ISOINPKTS	EP6 (if ISO) IN Packets per frame (1-3)	AADJ	0	0	0	0	0	INPPF1	INPPF0	00000001	brrrrb
E643	1	EP8ISOINPKTS	EP8 (if ISO) IN Packets per frame (1-3)	AADJ	0	0	0	0	0	INPPF1	INPPF0	00000001	brrrrr
E644	4	reserved											
E648	1	INPKTEND <sup>[8]</sup>	Force IN Packet End	Skip	0	0	0	EP3	EP2	EP1	EP0	xxxxxxx	W
E649	7	OUTPKTEND <sup>[8]</sup>	Force OUT Packet End	Skip	0	0	0	EP3	EP2	EP1	EP0	xxxxxxx	W
		INTERRUPTS											
E650	1	EP2FIFOIE <sup>[8]</sup>	Endpoint 2 slave FIFO Flag Interrupt Enable	0	0	0	0	EDGE PF	PF	EF	FF	00000000	RW
E651	1	EP2FIFOIRQ <sup>[8,9]</sup>	Endpoint 2 slave FIFO Flag Interrupt Request	0	0	0	0	0	PF	EF	FF	00000000	rrrrbb
E652	1	EP4FIFOIE <sup>[8]</sup>	Endpoint 4 slave FIFO Flag Interrupt Enable	0	0	0	0	EDGE PF	PF	EF	FF	00000000	RW
E653	1	EP4FIFOIRQ <sup>[8,9]</sup>	Endpoint 4 slave FIFO Flag Interrupt Request	0	0	0	0	0	PF	EF	FF	00000000	rrrrbb
E654	1	EP6FIFOIE <sup>[8]</sup>	Endpoint 6 slave FIFO Flag Interrupt Enable	0	0	0	0	EDGE PF	PF	EF	FF	00000000	RW
E655	1	EP6FIFOIRQ <sup>[8,9]</sup>	Endpoint 6 slave FIFO Flag Interrupt Request	0	0	0	0	0	PF	EF	FF	00000000	rrrrbb
E656	1	EP8FIFOIE <sup>[8]</sup>	Endpoint 8 slave FIFO Flag Interrupt Enable	0	0	0	0	EDGE PF	PF	EF	FF	00000000	RW
E657	1	EP8FIFOIRQ <sup>[8,9]</sup>	Endpoint 8 slave FIFO Flag Interrupt Request	0	0	0	0	0	PF	EF	FF	00000000	rrrrbb
E658	1	IBNIE	IN-BULK-NAK Interrupt Enable	0	0	EP8	EP6	EP4	EP2	EP1	EP0	00000000	RW
E659	1	IBNIRQ <sup>[8]</sup>	IN-BULK-NAK interrupt Request	0	0	EP8	EP6	EP4	EP2	EP1	EP0	00xxxxx	rrbbbbb
E65A	1	NAKIE	Endpoint Ping-NAK/IBN Interrupt Enable	EP8	EP6	EP4	EP2	EP1	EP0	0	IBN	00000000	RW

**Notes**

- 8. The register can only be reset, it cannot be set.
- 9. SFRs not part of the standard 8051 architecture.

**Table 9. NX2LP-Flex Register Summary (continued)**

Hex	Size	Name	Description	b7	b6	b5	b4	b3	b2	b1	b0	Default	Access
E65B	1	NAKIRQ <sup>[10]</sup>	Endpoint Ping-NAK/IBN Interrupt Request	EP8	EP6	EP4	EP2	EP1	EP0	0	IBN	xxxxx0x	bbbbbrb
E65C	1	USBIE	USB Int Enables	0	EP0ACK	HSGRANT	URES	SUSP	SUTOK	SOF	SUDAV	00000000	RW
E65D	1	USBIRQ <sup>[10]</sup>	USB Interrupt Requests	0	EP0ACK	HSGRANT	URES	SUSP	SUTOK	SOF	SUDAV	0xxxxxxx	rbbbbbbb
E65E	1	EPIE	Endpoint Interrupt Enables	EP8	EP6	EP4	EP2	EP1OUT	EP1IN	EP0OUT	EP0IN	00000000	RW
E65F	1	EPIRQ <sup>[10]</sup>	Endpoint Interrupt Requests	EP8	EP6	EP4	EP2	EP1OUT	EP1IN	EP0OUT	EP0IN	0	RW
E660	1	GPIFIE <sup>[10]</sup>	GPIF Interrupt Enable	0	0	0	0	0	0	GPIFWF	GPIFDONE	00000000	RW
E661	1	GPIFIRQ <sup>[10]</sup>	GPIF Interrupt Request	0	0	0	0	0	0	GPIFWF	GPIFDONE	000000xx	RW
E662	1	USBERRIE	USB Error Interrupt Enables	ISOEP8	ISOEP6	ISOEP4	ISOEP2	0	0	0	ERRLIMIT	00000000	RW
E663	1	USBERRIRQ <sup>[10]</sup>	USB Error Interrupt Requests	ISOEP8	ISOEP6	ISOEP4	ISOEP2	0	0	0	ERRLIMIT	0000000x	bbbbrrrb
E664	1	ERRCNTLIM	USB Error counter and limit	EC3	EC2	EC1	EC0	LIMIT3	LIMIT2	LIMIT1	LIMIT0	xxxx0100	rrrrbbbb
E665	1	CLRERRCNT	Clear Error Counter EC3:0	x	x	x	x	x	x	x	x	xxxxxxx	W
E666	1	INT2IVEC	Interrupt 2 (USB) Autovector	0	I2V4	I2V3	I2V2	I2V1	I2V0	0	0	00000000	R
E667	1	INT4IVEC	Interrupt 4 (slave FIFO & GPIF) Autovector	1	0	I4V3	I4V2	I4V1	I4V0	0	0	10000000	R
E668	1	INTSET-UP	Interrupt 2&4 setup	0	0	0	0	AV2EN	0	INT4SRC	AV4EN	00000000	RW
E669	7	reserved											
INPUT/OUTPUT													
E670	1	PORTACFG	I/O PORTA Alternate Configuration	FLAGD	SLCS	0	0	0	0	INT1	INT0	00000000	RW
E671	1	PORTCCFG	I/O PORTC Alternate Configuration	GPIFA7	GPIFA6	GPIFA5	GPIFA4	GPIFA3	GPIFA2	GPIFA1	GPIFA0	00000000	RW
E672	1	PORTECFG	I/O PORTE Alternate Configuration	GPIFA8	T2EX	INT6	RXD1OUT	RXD0OUT	T2OUT	T1OUT	T0OUT	00000000	RW
E673	4	XTALINSRC	XTALIN Clock Source	0	0	0	0	0	0	0	EXTCLK	00000000	rrrrrrrb
E677	1	reserved											
E678	1	I2CS	I <sup>2</sup> C Bus Control & Status	START	STOP	LASTRD	ID1	ID0	BERR	ACK	DONE	000x0000	bbbbrrrr
E679	1	I2DAT	I <sup>2</sup> C Bus Data	d7	d6	d5	d4	d3	d2	d1	d0	xxxxxxx	RW
E67A	1	I2CTL	I <sup>2</sup> C Bus Control	0	0	0	0	0	0	STOPIE	400kHz	00000000	RW
E67B	1	XAUTODAT1	Autopt1 MOVX access, when APTREN=1	D7	D6	D5	D4	D3	D2	D1	D0	xxxxxxx	RW
E67C	1	XAUTODAT2	Autopt2 MOVX access, when APTREN=1	D7	D6	D5	D4	D3	D2	D1	D0	xxxxxxx	RW
UDMA CRC													
E67D	1	UDMACRCH <sup>[10]</sup>	UDMA CRC MSB	CRC15	CRC14	CRC13	CRC12	CRC11	CRC10	CRC9	CRC8	01001010	RW
E67E	1	UDMACRCL <sup>[10]</sup>	UDMA CRC LSB	CRC7	CRC6	CRC5	CRC4	CRC3	CRC2	CRC1	CRC0	10111010	RW
E67F	1	UDMACRC-QUALIFIER	UDMA CRC Qualifier	QENABLE	0	0	0	QSTATE	Q SIGNAL2	Q SIGNAL1	Q SIGNAL0	00000000	bbbbrrrb
USB CONTROL													
E680	1	USBCS	USB Control & Status	HSM	0	0	0	DISCON	NOSYNSOF	RENUM	SIGRSUME	x0000000	rrrrbbbb
E681	1	SUSPEND	Put chip into suspend	x	x	x	x	x	x	x	x	xxxxxxx	W
E682	1	WAKEUPCS	WakeUp Control & Status	WU2	WU	WU2POL	WUPOL	0	DPEN	WU2EN	WUEN	xx000101	bbbbrrrb
E683	1	TOGCTL	Toggle Control	Q	S	R	I/O	EP3	EP2	EP1	EP0	x0000000	rrrrbbbb
E684	1	USBFRAMEH	USB Frame count H	0	0	0	0	0	FC10	FC9	FC8	00000xxx	R
E685	1	USBFRAMEL	USB Frame count L	FC7	FC6	FC5	FC4	FC3	FC2	FC1	FC0	xxxxxxx	R
E686	1	MICROFRAME	Microframe count, 0-7	0	0	0	0	0	MF2	MF1	MF0	00000xxx	R
E687	1	FNADDR	USB Function address	0	FA6	FA5	FA4	FA3	FA2	FA1	FA0	0xxxxxxx	R
E688	2	reserved											
ENDPOINTS													
E68A	1	EP0BCH <sup>[10]</sup>	Endpoint 0 Byte Count H (BC15)	(BC15)	(BC14)	(BC13)	(BC12)	(BC11)	(BC10)	(BC9)	(BC8)	xxxxxxx	RW
E68B	1	EP0BCL <sup>[10]</sup>	Endpoint 0 Byte Count L (BC7)	(BC7)	BC6	BC5	BC4	BC3	BC2	BC1	BC0	xxxxxxx	RW
E68C	1	reserved											
E68D	1	EP1OUTBC	Endpoint 1 OUT Byte Count	0	BC6	BC5	BC4	BC3	BC2	BC1	BC0	0xxxxxxx	RW
E68E	1	reserved											
E68F	1	EP1INBC	Endpoint 1 IN Byte Count	0	BC6	BC5	BC4	BC3	BC2	BC1	BC0	0xxxxxxx	RW
E690	1	EP2BCH <sup>[10]</sup>	Endpoint 2 Byte Count H	0	0	0	0	0	BC10	BC9	BC8	00000xxx	RW
E691	1	EP2BCL <sup>[10]</sup>	Endpoint 2 Byte Count L	BC7/SKIP	BC6	BC5	BC4	BC3	BC2	BC1	BC0	xxxxxxx	RW
E692	2	reserved											
E694	1	EP4BCH <sup>[10]</sup>	Endpoint 4 Byte Count H	0	0	0	0	0	0	BC9	BC8	000000xx	RW
E695	1	EP4BCL <sup>[10]</sup>	Endpoint 4 Byte Count L	BC7/SKIP	BC6	BC5	BC4	BC3	BC2	BC1	BC0	xxxxxxx	RW
E696	2	reserved											
E698	1	EP6BCH <sup>[10]</sup>	Endpoint 6 Byte Count H	0	0	0	0	0	BC10	BC9	BC8	00000xxx	RW
E699	1	EP6BCL <sup>[10]</sup>	Endpoint 6 Byte Count L	BC7/SKIP	BC6	BC5	BC4	BC3	BC2	BC1	BC0	xxxxxxx	RW

**Note**  
10. The register can only be reset, it cannot be set.

**Table 9. NX2LP-Flex Register Summary (continued)**

Hex	Size	Name	Description	b7	b6	b5	b4	b3	b2	b1	b0	Default	Access
E69A	2	reserved											
E69C	1	EP8BCH <sup>[11]</sup>	Endpoint 8 Byte Count H	0	0	0	0	0	0	BC9	BC8	000000xx	RW
E69D	1	EP8BCL <sup>[11]</sup>	Endpoint 8 Byte Count L	BC7/SKIP	BC6	BC5	BC4	BC3	BC2	BC1	BC0	xxxxxxx	RW
E69E	2	reserved											
E6A0	1	EP0CS	Endpoint 0 Control and Status	HSNAK	0	0	0	0	0	BUSY	STALL	10000000	bbbbbbbrb
E6A1	1	EP1OUTCS	Endpoint 1 OUT Control and Status	0	0	0	0	0	0	BUSY	STALL	00000000	bbbbbbbrb
E6A2	1	EP1INCS	Endpoint 1 IN Control and Status	0	0	0	0	0	0	BUSY	STALL	00000000	bbbbbbbrb
E6A3	1	EP2CS	Endpoint 2 Control and Status	0	NPAK2	NPAK1	NPAK0	FULL	EMPTY	0	STALL	00101000	rrrrrrb
E6A4	1	EP4CS	Endpoint 4 Control and Status	0	0	NPAK1	NPAK0	FULL	EMPTY	0	STALL	00101000	rrrrrrb
E6A5	1	EP6CS	Endpoint 6 Control and Status	0	NPAK2	NPAK1	NPAK0	FULL	EMPTY	0	STALL	00000100	rrrrrrb
E6A6	1	EP8CS	Endpoint 8 Control and Status	0	0	NPAK1	NPAK0	FULL	EMPTY	0	STALL	00000100	rrrrrrb
E6A7	1	EP2FIFOFLGS	Endpoint 2 slave FIFO Flags	0	0	0	0	0	PF	EF	FF	00000010	R
E6A8	1	EP4FIFOFLGS	Endpoint 4 slave FIFO Flags	0	0	0	0	0	PF	EF	FF	00000010	R
E6A9	1	EP6FIFOFLGS	Endpoint 6 slave FIFO Flags	0	0	0	0	0	PF	EF	FF	00000110	R
E6AA	1	EP8FIFOFLGS	Endpoint 8 slave FIFO Flags	0	0	0	0	0	PF	EF	FF	00000110	R
E6AB	1	EP2FIFOBCH	Endpoint 2 slave FIFO total byte count H	0	0	0	BC12	BC11	BC10	BC9	BC8	00000000	R
E6AC	1	EP2FIFOBCL	Endpoint 2 slave FIFO total byte count L	BC7	BC6	BC5	BC4	BC3	BC2	BC1	BC0	00000000	R
E6AD	1	EP4FIFOBCH	Endpoint 4 slave FIFO total byte count H	0	0	0	0	0	BC10	BC9	BC8	00000000	R
E6AE	1	EP4FIFOBCL	Endpoint 4 slave FIFO total byte count L	BC7	BC6	BC5	BC4	BC3	BC2	BC1	BC0	00000000	R
E6AF	1	EP6FIFOBCH	Endpoint 6 slave FIFO total byte count H	0	0	0	0	BC11	BC10	BC9	BC8	00000000	R
E6B0	1	EP6FIFOBCL	Endpoint 6 slave FIFO total byte count L	BC7	BC6	BC5	BC4	BC3	BC2	BC1	BC0	00000000	R
E6B1	1	EP8FIFOBCH	Endpoint 8 slave FIFO total byte count H	0	0	0	0	0	BC10	BC9	BC8	00000000	R
E6B2	1	EP8FIFOBCL	Endpoint 8 slave FIFO total byte count L	BC7	BC6	BC5	BC4	BC3	BC2	BC1	BC0	00000000	R
E6B3	1	SUDPTRH	Setup Data Pointer high address byte	A15	A14	A13	A12	A11	A10	A9	A8	xxxxxxx	RW
E6B4	1	SUDPTRL	Setup Data Pointer low address byte	A7	A6	A5	A4	A3	A2	A1	0	xxxxxxx0	bbbbbbbrb
E6B5	1	SUDPTRCTL	Setup Data Pointer Auto Mode	0	0	0	0	0	0	0	SDPAUTO	00000001	RW
	2	reserved											
E6B8	8	SET-UPDAT	8 bytes of setup data	D7	D6	D5	D4	D3	D2	D1	D0	xxxxxxx	R
			SET-UPDAT[0] = bmRequestType										
			SET-UPDAT[1] = bmRequest										
			SET-UPDAT[2:3] = wValue										
			SET-UPDAT[4:5] = wIndex										
			SET-UPDAT[6:7] = wLength										
			GPIF										
E6C0	1	GPIFWFSELECT	Waveform Selector	SINGLEWR1	SINGLEWR0	SINGLERD1	SINGLERD0	FIFOWR1	FIFOWR0	FIFORD1	FIFORD0	11100100	RW
E6C1	1	GPIFIDLECS	GPIF Done, GPIF IDLE drive mode	DONE	0	0	0	0	0	0	IDLEDRV	10000000	RW
E6C2	1	GPIFIDLECTL	Inactive Bus, CTL states	0	0	CTL5	CTL4	CTL3	CTL2	CTL1	CTL0	11111111	RW
E6C3	1	GPIFCTLCFG	CTL Drive Type	TRICTL	0	CTL5	CTL4	CTL3	CTL2	CTL1	CTL0	00000000	RW
E6C4	1	GPIFADR <sup>[11]</sup>	GPIF Address H	0	0	0	0	0	0	0	GPIFA8	00000000	RW
E6C5	1	GPIFADR <sup>[11]</sup>	GPIF Address L	GPIFA7	GPIFA6	GPIFA5	GPIFA4	GPIFA3	GPIFA2	GPIFA1	GPIFA0	00000000	RW
			FLOWSTATE										
E6C6	1	FLOWSTATE	Flowstate Enable and Selector	FSE	0	0	0	0	FS2	FS1	FS0	00000000	brrrrrbb
E6C7	1	FLOWLOGIC	Flowstate Logic	LFUNC1	LFUNC0	TERMA2	TERMA1	TERMA0	TERMB2	TERMB1	TERMB0	00000000	RW

**Note**

11. The register can only be reset, it cannot be set.

**Table 9. NX2LP-Flex Register Summary (continued)**

Hex	Size	Name	Description	b7	b6	b5	b4	b3	b2	b1	b0	Default	Access
E6C8	1	FLOWEQ0CTL	CTL-Pin States in Flowstate (when Logic = 0)	CTL0E3	CTL0E2	CTL0E1 / CTL5	CTL0E0 / CTL4	CTL3	CTL2	CTL1	CTL0	00000000	RW
E6C9	1	FLOWEQ1CTL	CTL-Pin States in Flowstate (when Logic = 1)	CTL0E3	CTL0E2	CTL0E1 / CTL5	CTL0E0 / CTL4	CTL3	CTL2	CTL1	CTL0	00000000	RW
E6CA	1	FLOWHOLDOFF	Holdoff Configuration	HOPERIOD3	HOPERIOD2	HOPERIOD1	HOPERIOD0	HOSTATE	HOCTL2	HOCTL1	HOCTL0	00010010	RW
E6CB	1	FLOWSTB	Flowstate Strobe Configuration	SLAVE	RDYASYN	CTLTOGL	SUSTAIN	0	MSTB2	MSTB1	MSTB0	00100000	RW
E6CC	1	FLOWSTBEDGE	Flowstate Rising/Falling Edge Configuration	0	0	0	0	0	0	FALLING	RISING	00000001	rrrrrrbb
E6CD	1	FLOWSTBPERIOD	Master-Strobe Half-Period	D7	D6	D5	D4	D3	D2	D1	D0	00000010	RW
E6CE	1	GPIFTCB3 <sup>[12]</sup>	GPIF Transaction Count Byte 3	TC31	TC30	TC29	TC28	TC27	TC26	TC25	TC24	00000000	RW
E6CF	1	GPIFTCB2 <sup>[12]</sup>	GPIF Transaction Count Byte 2	TC23	TC22	TC21	TC20	TC19	TC18	TC17	TC16	00000000	RW
E6D0	1	GPIFTCB1 <sup>[12]</sup>	GPIF Transaction Count Byte 1	TC15	TC14	TC13	TC12	TC11	TC10	TC9	TC8	00000000	RW
E6D1	1	GPIFTCB0 <sup>[12]</sup>	GPIF Transaction Count Byte 0	TC7	TC6	TC5	TC4	TC3	TC2	TC1	TC0	00000001	RW
	2	reserved										00000000	RW
		reserved											
		reserved				1							
E6D2	1	EP2GPIFFLGSEL <sup>[12]</sup>	Endpoint 2 GPIF Flag select	0	0	0	0	0	0	FS1	FS0	00000000	RW
E6D3	1	EP2GPIPFSTOP	Endpoint 2 GPIF stop transaction on prog. flag	0	0	0	0	0	0	0	FIFO2FLAG	00000000	RW
E6D4	1	EP2GPIFTRIG <sup>[12]</sup>	Endpoint 2 GPIF Trigger	x	x	x	x	x	x	x	x	xxxxxxx	W
	3	reserved											
		reserved											
		reserved											
E6DA	1	EP4GPIFFLGSEL <sup>[12]</sup>	Endpoint 4 GPIF Flag select	0	0	0	0	0	0	FS1	FS0	00000000	RW
E6DB	1	EP4GPIPFSTOP	Endpoint 4 GPIF stop transaction on GPIF Flag	0	0	0	0	0	0	0	FIFO4FLAG	00000000	RW
E6DC	1	EP4GPIFTRIG <sup>[12]</sup>	Endpoint 4 GPIF Trigger	x	x	x	x	x	x	x	x	xxxxxxx	W
	3	reserved											
		reserved											
		reserved											
E6E2	1	EP6GPIFFLGSEL <sup>[12]</sup>	Endpoint 6 GPIF Flag select	0	0	0	0	0	0	FS1	FS0	00000000	RW
E6E3	1	EP6GPIPFSTOP	Endpoint 6 GPIF stop transaction on prog. flag	0	0	0	0	0	0	0	FIFO6FLAG	00000000	RW
E6E4	1	EP6GPIFTRIG <sup>[12]</sup>	Endpoint 6 GPIF Trigger	x	x	x	x	x	x	x	x	xxxxxxx	W
	3	reserved											
		reserved											
		reserved											
E6EA	1	EP8GPIFFLGSEL <sup>[12]</sup>	Endpoint 8 GPIF Flag select	0	0	0	0	0	0	FS1	FS0	00000000	RW
E6EB	1	EP8GPIPFSTOP	Endpoint 8 GPIF stop transaction on prog. flag	0	0	0	0	0	0	0	FIFO8FLAG	00000000	RW
E6EC	1	EP8GPIFTRIG <sup>[12]</sup>	Endpoint 8 GPIF Trigger	x	x	x	x	x	x	x	x	xxxxxxx	W
	3	reserved											
E6F0	1	XGPIFSGLDATH	GPIF Data H (16-bit mode only)	D15	D14	D13	D12	D11	D10	D9	D8	xxxxxxx	RW
E6F1	1	XGPIFSGLDATLX	Read/Write GPIF Data L & trigger transaction	D7	D6	D5	D4	D3	D2	D1	D0	xxxxxxx	RW
E6F2	1	XGPIFSGLDATLNOX	Read GPIF Data L, no transaction trigger	D7	D6	D5	D4	D3	D2	D1	D0	xxxxxxx	R
E6F3	1	GPIFREADYCFG	Internal RDY, Sync/Async, RDY pin states	INTRDY	SAS	TCXRDY5	0	0	0	0	0	00000000	bbrrrr
E6F4	1	GPIFREADYSTAT	GPIF Ready Status	0	0	RDY5	RDY4	RDY3	RDY2	RDY1	RDY0	00xxxxxx	R
E6F5	1	GPIFABORT	Abort GPIF Waveforms	x	x	x	x	x	x	x	x	xxxxxxx	W
E6F6	2	reserved											
		ENDPOINT BUFFERS											
E740	64	EP0BUF	EP0-IN/-OUT buffer	D7	D6	D5	D4	D3	D2	D1	D0	xxxxxxx	RW
E780	64	EP10OUTBUF	EP1-OUT buffer	D7	D6	D5	D4	D3	D2	D1	D0	xxxxxxx	RW
E7C0	64	EP1INBUF	EP1-IN buffer	D7	D6	D5	D4	D3	D2	D1	D0	xxxxxxx	RW
	2048	reserved											RW

**Note**  
12. The register can only be reset, it cannot be set.

**Table 9. NX2LP-Flex Register Summary (continued)**

Hex	Size	Name	Description	b7	b6	b5	b4	b3	b2	b1	b0	Default	Access
F000	1024	EP2FIFOBUF	512/1024-byte EP 2/slave FIFO buffer (IN or OUT)	D7	D6	D5	D4	D3	D2	D1	D0	xxxxxxx	RW
F400	512	EP4FIFOBUF	512 byte EP 4/slave FIFO buffer (IN or OUT)	D7	D6	D5	D4	D3	D2	D1	D0	xxxxxxx	RW
F600	512	reserved											
F800	1024	EP6FIFOBUF	512/1024-byte EP 6/slave FIFO buffer (IN or OUT)	D7	D6	D5	D4	D3	D2	D1	D0	xxxxxxx	RW
FC00	512	EP8FIFOBUF	512 byte EP 8/slave FIFO buffer (IN or OUT)	D7	D6	D5	D4	D3	D2	D1	D0	xxxxxxx	RW
FE00	512	reserved											
xxxx		I <sup>2</sup> C Configuration Byte		0	DISCON	0	0	0	0	0	400 kHz	xxxxxxx <sup>14</sup>	n/a
Special Function Registers (SFRs)													
80	1	IOA <sup>[13]</sup>	Port A (bit addressable)	D7	D6	D5	D4	D3	D2	D1	D0	xxxxxxx	RW
81	1	SP	Stack Pointer	D7	D6	D5	D4	D3	D2	D1	D0	0000111	RW
82	1	DPL0	Data Pointer 0 L	A7	A6	A5	A4	A3	A2	A1	A0	00000000	RW
83	1	DPH0	Data Pointer 0 H	A15	A14	A13	A12	A11	A10	A9	A8	00000000	RW
84	1	DPL1 <sup>[13]</sup>	Data Pointer 1 L	A7	A6	A5	A4	A3	A2	A1	A0	00000000	RW
85	1	DPH1 <sup>[13]</sup>	Data Pointer 1 H	A15	A14	A13	A12	A11	A10	A9	A8	00000000	RW
86	1	DPS <sup>[13]</sup>	Data Pointer 0/1 select	0	0	0	0	0	0	0	SEL	00000000	RW
87	1	PCON	Power Control	SMOD0	x	1	1	x	x	x	IDLE	00110000	RW
88	1	TCON	Timer/Counter Control (bit addressable)	TF1	TR1	TF0	TR0	IE1	IT1	IE0	IT0	00000000	RW
89	1	TMOD	Timer/Counter Mode Control	GATE	CT	M1	M0	GATE	CT	M1	M0	00000000	RW
8A	1	TL0	Timer 0 reload L	D7	D6	D5	D4	D3	D2	D1	D0	00000000	RW
8B	1	TL1	Timer 1 reload L	D7	D6	D5	D4	D3	D2	D1	D0	00000000	RW
8C	1	TH0	Timer 0 reload H	D15	D14	D13	D12	D11	D10	D9	D8	00000000	RW
8D	1	TH1	Timer 1 reload H	D15	D14	D13	D12	D11	D10	D9	D8	00000000	RW
8E	1	CKCON <sup>[13]</sup>	Clock Control	x	x	T2M	T1M	T0M	MD2	MD1	MD0	00000001	RW
8F	1	reserved											
90	1	IOB <sup>[13]</sup>	Port B (bit addressable)	D7	D6	D5	D4	D3	D2	D1	D0	xxxxxxx	RW
91	1	EXIF <sup>[13]</sup>	External Interrupt Flag(s)	IE5	IE4	I <sup>2</sup> CINT	USBNT	1	0	0	0	00001000	RW
92	1	MPAGE <sup>[13]</sup>	Upper Addr Byte of MOVX using @R0/@R1	A15	A14	A13	A12	A11	A10	A9	A8	00000000	RW
93	5	reserved											
98	1	SCON0	Serial Port 0 Control (bit addressable)	SM0_0	SM1_0	SM2_0	REN_0	TB8_0	RB8_0	TI_0	RI_0	00000000	RW
99	1	SBUF0	Serial Port 0 Data Buffer	D7	D6	D5	D4	D3	D2	D1	D0	00000000	RW
9A	1	AUTOPTRH1 <sup>[13]</sup>	Autopointer 1 Address H	A15	A14	A13	A12	A11	A10	A9	A8	00000000	RW
9B	1	AUTOPTRL1 <sup>[13]</sup>	Autopointer 1 Address L	A7	A6	A5	A4	A3	A2	A1	A0	00000000	RW
9C	1	reserved											
9D	1	AUTOPTRH2 <sup>[13]</sup>	Autopointer 2 Address H	A15	A14	A13	A12	A11	A10	A9	A8	00000000	RW
9E	1	AUTOPTRL2 <sup>[13]</sup>	Autopointer 2 Address L	A7	A6	A5	A4	A3	A2	A1	A0	00000000	RW
9F	1	reserved											
A0	1	IOC <sup>[13]</sup>	Port C (bit addressable)	D7	D6	D5	D4	D3	D2	D1	D0	xxxxxxx	RW
A1	1	INT2CLR <sup>[13]</sup>	Interrupt 2 clear	x	x	x	x	x	x	x	x	xxxxxxx	W
A2	1	INT4CLR <sup>[13]</sup>	Interrupt 4 clear	x	x	x	x	x	x	x	x	xxxxxxx	W
A3	5	reserved											
A8	1	IE	Interrupt Enable (bit addressable)	EA	ES1	ET2	ES0	ET1	EX1	ET0	EX0	00000000	RW
A9	1	reserved											
AA	1	EP2468STAT <sup>[13]</sup>	Endpoint 2,4,6,8 status flags	EP8F	EP8E	EP6F	EP6E	EP4F	EP4E	EP2F	EP2E	01011010	R
AB	1	EP24FIFOFLGS <sup>[13]</sup>	Endpoint 2,4 slave FIFO status flags	0	EP4PF	EP4EF	EP4FF	0	EP2PF	EP2EF	EP2FF	00100010	R
AC	1	EP68FIFOFLGS <sup>[13]</sup>	Endpoint 6,8 slave FIFO status flags	0	EP8PF	EP8EF	EP8FF	0	EP6PF	EP6EF	EP6FF	01100110	R
AD	2	reserved											
AF	1	AUTOPTRSET-UP <sup>[13]</sup>	Autopointer 1&2 setup	0	0	0	0	0	APTR2INC	APTR1INC	APTREN	00000110	RW
B0	1	IOD <sup>[13]</sup>	Port D (bit addressable)	D7	D6	D5	D4	D3	D2	D1	D0	xxxxxxx	RW
B1	1	IOE <sup>[13]</sup>	Port E (NOT bit addressable)	D7	D6	D5	D4	D3	D2	D1	D0	xxxxxxx	RW
B2	1	OEA <sup>[13]</sup>	Port A Output Enable	D7	D6	D5	D4	D3	D2	D1	D0	00000000	RW
B3	1	OEB <sup>[13]</sup>	Port B Output Enable	D7	D6	D5	D4	D3	D2	D1	D0	00000000	RW
B4	1	OEC <sup>[13]</sup>	Port C Output Enable	D7	D6	D5	D4	D3	D2	D1	D0	00000000	RW
B5	1	OED <sup>[13]</sup>	Port D Output Enable	D7	D6	D5	D4	D3	D2	D1	D0	00000000	RW
B6	1	OEE <sup>[13]</sup>	Port E Output Enable	D7	D6	D5	D4	D3	D2	D1	D0	00000000	RW
B7	1	reserved											

**Notes**

- 13. SFRs not part of the standard 8051 architecture.
- 14. If no NAND is detected by the SIE then the default is 00000000.

**Table 9. NX2LP-Flex Register Summary (continued)**

Hex	Size	Name	Description	b7	b6	b5	b4	b3	b2	b1	b0	Default	Access
B8	1	IP	Interrupt Priority (bit addressable)	1	PS1	PT2	PS0	PT1	PX1	PT0	PX0	10000000	RW
B9	1	reserved											
BA	1	EP01STAT <sup>[15]</sup>	Endpoint 0&1 Status	0	0	0	0	0	EP1INBSY	EP1OUTBSY	EP0BSY	00000000	R
BB	1	GPIFTRIG <sup>[15, 16]</sup>	Endpoint 2,4,6,8 GPIF slave FIFO Trigger	DONE	0	0	0	0	RW	EP1	EP0	10000xxx	brrrbbb
BC	1	reserved											
BD	1	GPIFSGLDATH <sup>[15]</sup>	GPIF Data H (16-bit mode only)	D15	D14	D13	D12	D11	D10	D9	D8	xxxxxxx	RW
BE	1	GPIFSGLDATLX <sup>[15]</sup>	GPIF Data L w/Trigger	D7	D6	D5	D4	D3	D2	D1	D0	xxxxxxx	RW
BF	1	GPIFSGLDATLNOX <sup>[15]</sup>	GPIF Data L w/No Trigger	D7	D6	D5	D4	D3	D2	D1	D0	xxxxxxx	R
C0	1	SCON1 <sup>[15]</sup>	Serial Port 1 Control (bit addressable)	SM0_1	SM1_1	SM2_1	REN_1	TB8_1	RB8_1	TL_1	RL_1	00000000	RW
C1	1	SBUF1 <sup>[15]</sup>	Serial Port 1 Data Buffer	D7	D6	D5	D4	D3	D2	D1	D0	00000000	RW
C2	6	reserved											
C8	1	T2CON	Timer/Counter 2 Control (bit addressable)	TF2	EXF2	RCLK	TCLK	EXEN2	TR2	CT2	CPRL2	00000000	RW
C9	1	reserved											
CA	1	RCAP2L	Capture for Timer 2, auto-reload, up-counter	D7	D6	D5	D4	D3	D2	D1	D0	00000000	RW
CB	1	RCAP2H	Capture for Timer 2, auto-reload, up-counter	D7	D6	D5	D4	D3	D2	D1	D0	00000000	RW
CC	1	TL2	Timer 2 reload L	D7	D6	D5	D4	D3	D2	D1	D0	00000000	RW
CD	1	TH2	Timer 2 reload H	D15	D14	D13	D12	D11	D10	D9	D8	00000000	RW
CE	2	reserved											
D0	1	PSW	Program Status Word (bit addressable)	CY	AC	F0	RS1	RS0	OV	F1	P	00000000	RW
D1	7	reserved											
D8	1	EICON <sup>[15]</sup>	External Interrupt Control	SMOD1	1	ERESI	RESI	INT6	0	0	0	01000000	RW
D9	7	reserved											
E0	1	ACC	Accumulator (bit addressable)	D7	D6	D5	D4	D3	D2	D1	D0	00000000	RW
E1	7	reserved											
E8	1	EIE <sup>[15]</sup>	External Interrupt Enable(s)	1	1	1	EX6	EX5	EX4	EIP <sup>c</sup>	EUSB	11100000	RW
E9	7	reserved											
F0	1	B	B (bit addressable)	D7	D6	D5	D4	D3	D2	D1	D0	00000000	RW
F1	7	reserved											
F8	1	EIP <sup>[15]</sup>	External Interrupt Priority Control	1	1	1	PX6	PX5	PX4	PI <sup>c</sup>	PUSB	11100000	RW
F9	7	reserved											

R = all bits read-only  
W = all bits write-only  
r = read-only bit  
w = write-only bit  
b = both read/write bit

**Notes**

- 15. SFRs not part of the standard 8051 architecture.
- 16. If no NAND is detected by the SIE then the default is 00000000.

## Absolute Maximum Ratings

Exceeding maximum ratings may impair the useful life of the device. These user guidelines are not tested.

Storage Temperature .....	-65 °C to +150 °C
Ambient Temperature with Power Supplied (Commercial) .....	0 °C to +70 °C
Ambient Temperature with Power Supplied (Industrial) .....	-40 °C to +105 °C
Supply Voltage to Ground Potential .....	-0.5 V to +4.0 V
DC Input Voltage to any Input Pin .....	+5.25 V <sup>[17]</sup>
DC Voltage Applied to Outputs in High Z State .....	-0.5 V to V <sub>CC</sub> + 0.5 V

Power Dissipation .....	300 mW
Static Discharge Voltage .....	> 2000 V
Max Output Current, per I/O port .....	10 mA

## Operating Conditions

T <sub>A</sub> (Ambient Temperature Under Bias) Commercial .....	0 °C to +70 °C
T <sub>A</sub> (Ambient Temperature Under Bias) Industrial .....	-40 °C to +105 °C
Supply Voltage .....	+3.00 V to +3.60 V
Ground Voltage .....	0 V
F <sub>OSC</sub> (Oscillator or Crystal Frequency) .....	24 MHz ± 100 ppm (Parallel Resonant)

## DC Electrical Characteristics

Parameter	Description	Conditions	Min	Typ	Max	Unit
V <sub>CC</sub>	Supply voltage		3.00	3.3	3.60	V
V <sub>CC</sub> ramp up	0 to 3.3 V		200	-	-	µs
V <sub>IH</sub>	Input HIGH voltage		2	-	5.25	V
V <sub>IL</sub>	Input LOW voltage		-0.5	-	0.8	V
V <sub>IH_X</sub>	Crystal input HIGH voltage		2	-	5.25	V
V <sub>IL_X</sub>	Crystal input LOW voltage		-0.5	-	0.8	V
I <sub>I</sub>	Input leakage current	0 < V <sub>IN</sub> < V <sub>CC</sub>	-	-	±10	µA
V <sub>OH</sub>	Output voltage HIGH	I <sub>OUT</sub> = 4 mA	2.4	-	-	V
V <sub>OL</sub>	Output voltage LOW	I <sub>OUT</sub> = -4 mA	-	-	0.4	V
I <sub>OH</sub>	Output current HIGH		-	-	4	mA
I <sub>OL</sub>	Output current LOW		-	-	4	mA
C <sub>IN</sub>	Input pin capacitance	Except D+/D-	-	-	10	pF
		D+/D-	-	-	15	pF
I <sub>SUSP</sub>	Suspend current CY7C68034	Connected	-	300	380 <sup>[18]</sup>	µA
		Disconnected	-	100	150 <sup>[18]</sup>	µA
	Suspend current CY7C68033	Connected	-	0.5	1.2 <sup>[18]</sup>	mA
		Disconnected	-	0.3	1.0 <sup>[18]</sup>	mA
I <sub>CC</sub>	Supply current	8051 running, connected to USB HS	-	43	-	mA
		8051 running, connected to USB FS	-	35	-	mA
I <sub>UNCONFIG</sub>	Unconfigured current	Before bMaxPower granted by host	-	43	-	mA
T <sub>RESET</sub>	Reset time after valid power	V <sub>CC</sub> min = 3.0 V	5.0	-	-	ms
	Pin reset after powered on		200	-	-	µs

## USB Transceiver

USB 2.0-compliant in full and high speed modes.

### Notes

17. Applying power to I/O pins when the chip is not powered is not recommended.  
 18. Measured at Max V<sub>CC</sub>, 25 °C.

## AC Electrical Characteristics

### USB Transceiver

USB 2.0-compliant in full and high speed modes.

#### Slave FIFO Asynchronous Read

Figure 11. Slave FIFO Asynchronous Read Timing Diagram <sup>[19]</sup>

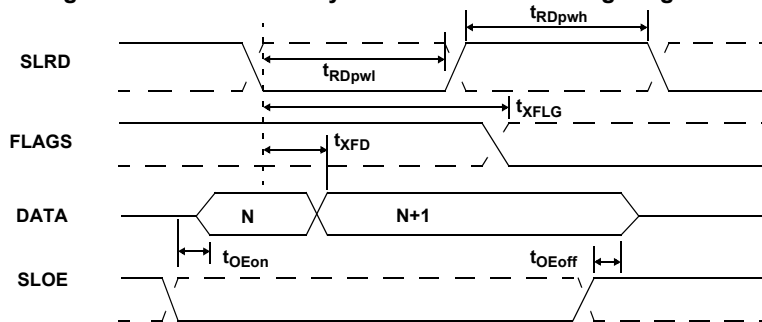

Table 10. Slave FIFO Asynchronous Read Parameters <sup>[20]</sup>

Parameter	Description	Min	Max	Unit
$t_{RDpwl}$	SLRD pulse width LOW	50	–	ns
$t_{RDpwh}$	SLRD pulse width HIGH	50	–	ns
$t_{XFLG}$	SLRD to FLAGS output propagation delay	–	70	ns
$t_{XFD}$	SLRD to FIFO data output propagation delay	–	15	ns
$t_{OEon}$	SLOE turn on to FIFO data valid	–	10.5	ns
$t_{OEoff}$	SLOE turn off to FIFO data hold	–	10.5	ns

#### Slave FIFO Asynchronous Write

Figure 12. Slave FIFO Asynchronous Write Timing Diagram <sup>[19]</sup>

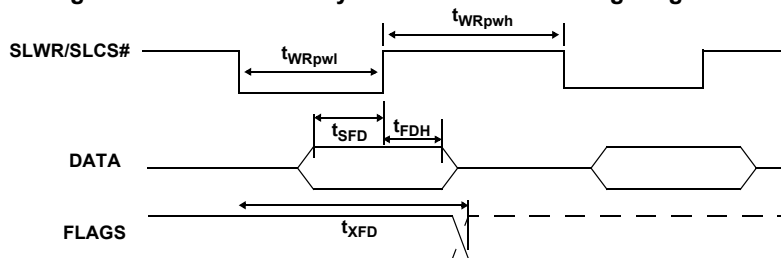

Table 11. Slave FIFO Asynchronous Write Parameters with Internally Sourced IFCLK <sup>[21]</sup>

Parameter	Description	Min	Max	Unit
$t_{WRpwl}$	SLWR pulse LOW	50	–	ns
$t_{WRpwh}$	SLWR pulse HIGH	70	–	ns
$t_{SFD}$	SLWR to FIFO DATA setup time	10	–	ns
$t_{FDH}$	FIFO DATA to SLWR hold time	10	–	ns
$t_{XFD}$	SLWR to FLAGS output propagation delay	–	70	ns

#### Notes

19. Dashed lines denote signals with programmable polarity.

20. Slave FIFO asynchronous parameter values use internal IFCLK setting at 48 MHz.

21. GPIF asynchronous RDY<sub>x</sub> signals have a minimum setup time of 50 ns when using internal 48 MHz IFCLK.

### Slave FIFO Asynchronous Packet End Strobe

Figure 13. Slave FIFO Asynchronous Packet End Strobe Timing Diagram <sup>[22]</sup>

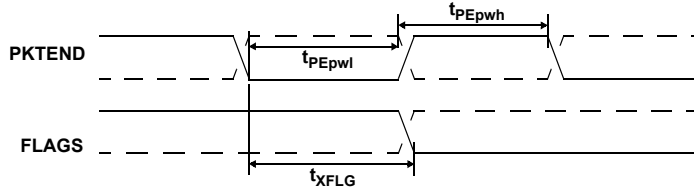

Table 12. Slave FIFO Asynchronous Packet End Strobe Parameters <sup>[23]</sup>

Parameter	Description	Min	Max	Unit
$t_{PEpwl}$	PKTEND pulse width LOW	50	–	ns
$t_{PEpwh}$	PKTEND pulse width HIGH	50	–	ns
$t_{XFLG}$	PKTEND to FLAGS output propagation delay	–	115	ns

### Slave FIFO Output Enable

Figure 14. Slave FIFO Output Enable Timing Diagram <sup>[24]</sup>

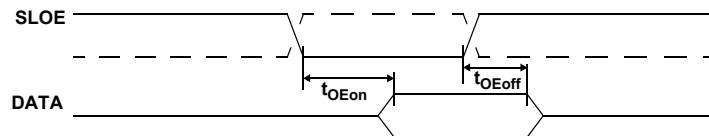

Table 13. Slave FIFO Output Enable Parameters

Parameter	Description	Min	Max	Unit
$t_{OEon}$	SLOE assert to FIFO DATA output	–	10.5	ns
$t_{OEoff}$	SLOE deassert to FIFO DATA hold	–	10.5	ns

**Notes**

- 22. SFRs not part of the standard 8051 architecture.
- 23. Slave FIFO asynchronous parameter values use internal IFCLK setting at 48 MHz.
- 24. Dashed lines denote signals with programmable polarity.

### Slave FIFO Address to Flags/Data

Figure 15. Slave FIFO Address to Flags/Data Timing Diagram <sup>[25]</sup>

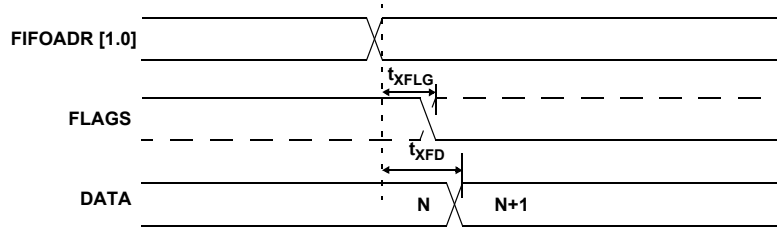

Table 14. Slave FIFO Address to Flags/Data Parameters

Parameter	Description	Min	Max	Unit
$t_{XFLG}$	FIFOADR[1:0] to FLAGS output propagation delay	–	10.7	ns
$t_{XFD}$	FIFOADR[1:0] to FIFODATA output propagation delay	–	14.3	ns

### Slave FIFO Asynchronous Address

Figure 16. Slave FIFO Asynchronous Address Timing Diagram <sup>[25]</sup>

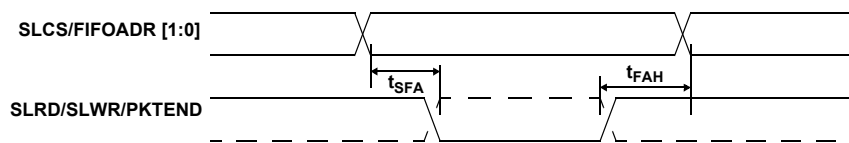

Table 15. Slave FIFO Asynchronous Address Parameters <sup>[26]</sup>

Parameter	Description	Min	Max	Unit
$t_{SFA}$	FIFOADR[1:0] to SLRD/SLWR/PKTEND Setup Time	10	–	ns
$t_{FAH}$	RD/WR/PKTEND to FIFOADR[1:0] Hold Time	10	–	ns

#### Notes

25. Dashed lines denote signals with programmable polarity.  
26. Slave FIFO asynchronous parameter values use internal IFCLK setting at 48 MHz.

## Sequence Diagram

Sequence Diagram of a Single and Burst Asynchronous Read

Figure 17. Slave FIFO Asynchronous Read Sequence and Timing Diagram [27]

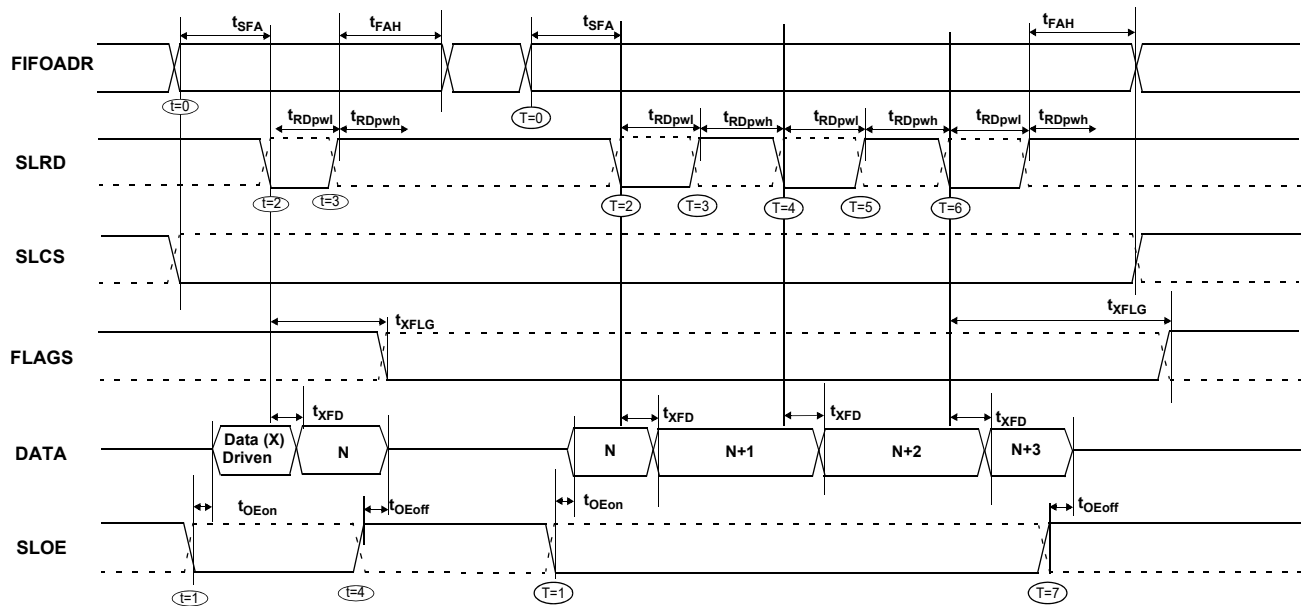

Figure 18. Slave FIFO Asynchronous Read Sequence of Events Diagram

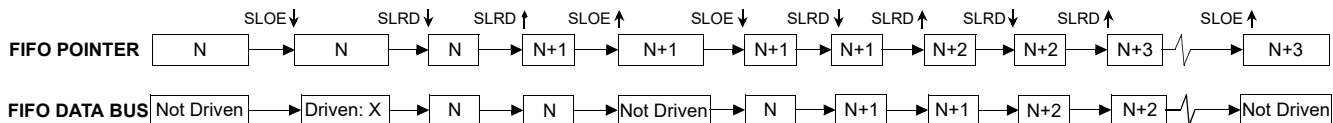

Figure 17 shows the timing relationship of the SLAVE FIFO signals during an asynchronous FIFO read. It shows a single read followed by a burst read.

- At  $t = 0$  the FIFO address is stable and the SLCS signal is asserted.
- At  $t = 1$ , SLOE is asserted. This results in the data bus being driven. The data that is driven on to the bus is previous data, it data that was in the FIFO from a prior read cycle.
- At  $t = 2$ , SLRD is asserted. The SLRD must meet the minimum active pulse of  $t_{RDpwl}$  and minimum inactive pulse width of  $t_{RDpwh}$ . If SLCS is used then, SLCS must be in asserted with SLRD or before SLRD is asserted (that is the SLCS and SLRD signals must both be asserted to start a valid read condition).

- The data that is driven, after asserting SLRD, is the updated data from the FIFO. This data is valid after a propagation delay of  $t_{x_{FD}}$  from the activating edge of SLRD. In Figure 17, data N is the first valid data read from the FIFO. For data to appear on the data bus during the read cycle (that is SLRD is asserted), SLOE MUST be in an asserted state. SLRD and SLOE can also be tied together.

The same sequence of events is also shown for a burst read marked with T = 0 through 5.

**Note** In burst read mode, during SLOE is assertion, the data bus is in a driven state and outputs the previous data. After SLRD is asserted, the data from the FIFO is driven on the data bus (SLOE must also be asserted) and then the FIFO pointer is incremented.

**Note**

27. Dashed lines denote signals with programmable polarity.

Sequence Diagram of a Single and Burst Asynchronous Write

Figure 19. Slave FIFO Asynchronous Write Sequence and Timing Diagram [28]

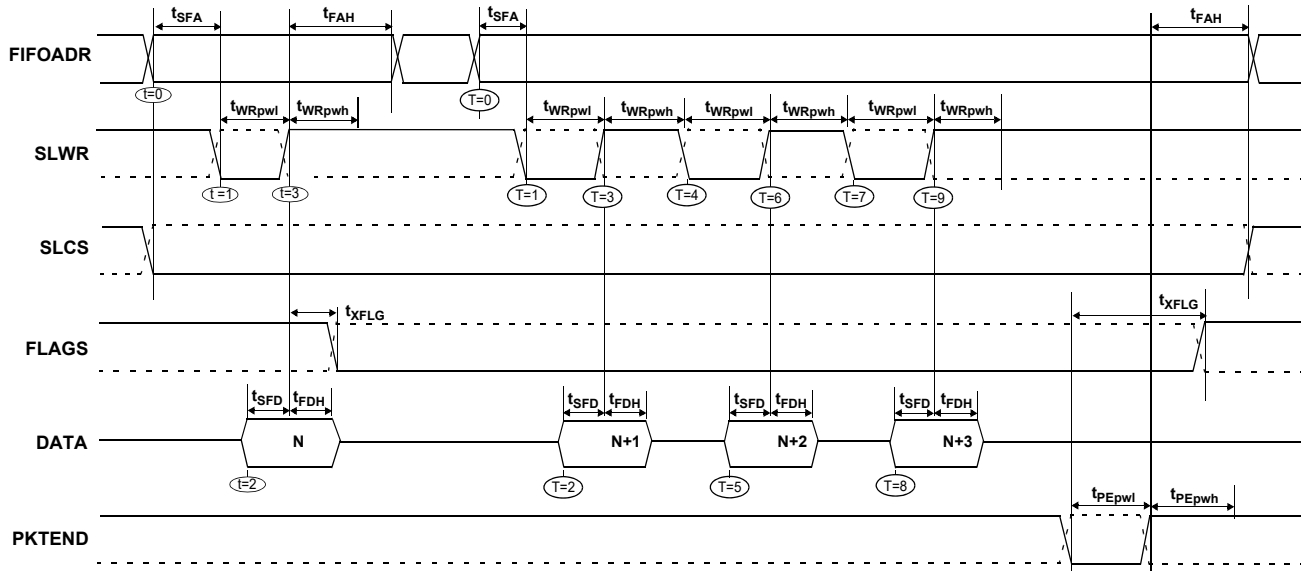

Figure 19 shows the timing relationship of the SLAVE FIFO write in an asynchronous mode. The diagram shows a single write followed by a burst write of three bytes and committing the 4-byte-short packet using PKTEND.

- At  $t = 0$  the FIFO address is applied, insuring that it meets the setup time of  $t_{SFA}$ . If SLCS is used, it must also be asserted (SLCS may be tied low in some applications).
- At  $t = 1$  SLWR is asserted. SLWR must meet the minimum active pulse of  $t_{WRpwl}$  and minimum de-active pulse width of  $t_{WRpwh}$ . If the SLCS is used, it must be in asserted with SLWR or before SLWR is asserted.
- At  $t = 2$ , data must be present on the bus  $t_{SFD}$  before the deasserting edge of SLWR.

At  $t = 3$ , deasserting SLWR causes the data to be written from the data bus to the FIFO and then increments the FIFO pointer.

The FIFO flag is also updated after  $t_{XFLG}$  from the deasserting edge of SLWR.

The same sequence of events are shown for a burst write and is indicated by the timing marks of  $T = 0$  through 5.

**Note** In the burst write mode, after SLWR is deasserted, the data is written to the FIFO and then the FIFO pointer is incremented to the next byte in the FIFO. The FIFO pointer is post incremented.

As shown in Figure 19 after the four bytes are written to the FIFO and SLWR is deasserted, the short 4-byte packet can be committed to the host using the PKTEND. The external device should be designed to not assert SLWR and the PKTEND signal at the same time. It should be designed to assert the PKTEND after SLWR is deasserted and met the minimum de-asserted pulse width. The FIFOADDR lines are to be held constant during the PKTEND assertion.

**Note**  
28. Dashed lines denote signals with programmable polarity.

### Ordering Information

Ordering Code	Description
<b>Silicon for battery-powered applications</b>	
CY7C68034-56LTXI	8 × 8 mm, 56-pin QFN (Sawn)
<b>Silicon for non-battery-powered applications</b>	
CY7C68033-56LTXC	8 × 8 mm, 56-pin QFN (Sawn)

### Ordering Code Definitions

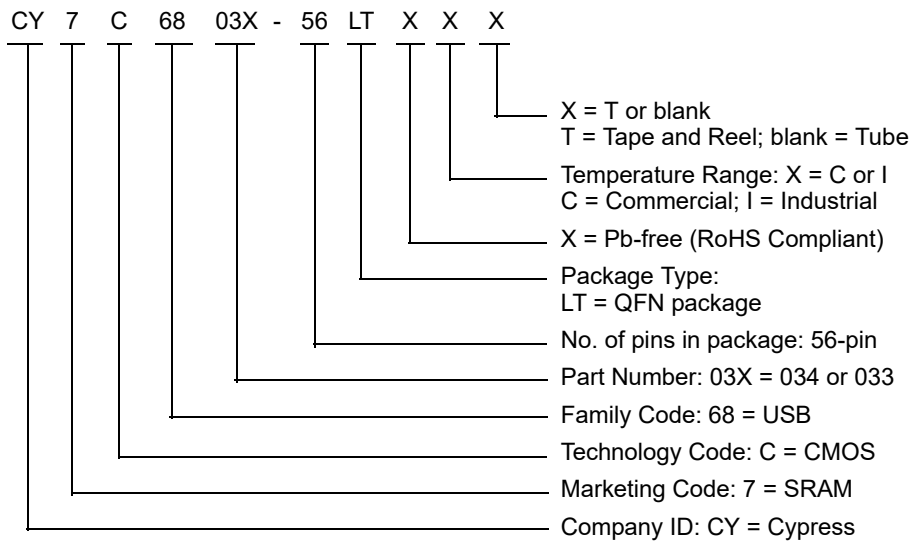

### Package Diagrams

Figure 20. 56-pin QFN ((8 × 8 × 1.0 mm) 4.5 × 5.2 E-Pad (Sawn)) Package Outline, 001-53450

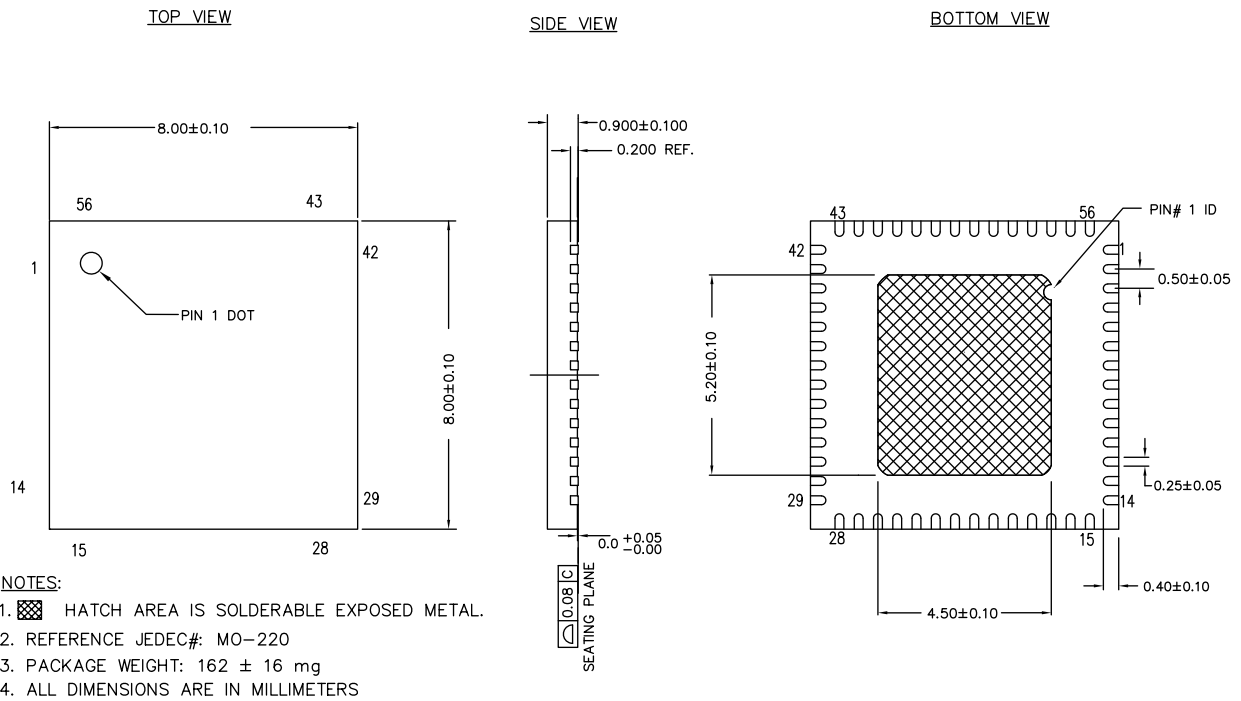

001-53450 \*E

## PCB Layout Recommendations

Follow these recommendations <sup>[29]</sup> to ensure reliable high performance operation:

- At least a four-layer impedance controlled boards is recommended to maintain signal quality.
- Specify impedance targets (ask your board vendor what they can achieve) to meet USB specifications.
- To control impedance, maintain trace widths and trace spacing.
- Minimize any stubs to avoid reflected signals.
- Connections between the USB connector shell and signal ground must be done near the USB connector.
- Bypass/flyback caps on VBUS, near connector, are recommended.
- DPLUS and DMINUS trace lengths should be kept to within 2 mm of each other in length, with preferred length of 20–30 mm.
- Maintain a solid ground plane under the DPLUS and DMINUS traces. Do not allow the plane to be split under these traces.

- No vias should be placed on the DPLUS or DMINUS trace routing unless absolutely necessary.
- Isolate the DPLUS and DMINUS traces from all other signal traces as much as possible.

## Quad Flat Package No Leads (QFN) Package Design Notes

Electrical contact of the part to the printed circuit board (PCB) is made by soldering the leads on the bottom surface of the package to the PCB. Therefore, special attention is required to the heat transfer area below the package to provide a good thermal bond to the circuit board. Design a copper (Cu) fill into the PCB as a thermal pad under the package. Heat is transferred from the NX2LP-Flex to the PCB through the device's metal paddle on the bottom side of the package. It is then conducted from the PCB's thermal pad to the inner ground plane by a  $5 \times 5$  array of vias. A via is a plated through hole in the PCB with a finished diameter of 13 mil. The QFN's metal die paddle must be soldered to the PCB's thermal pad. Solder mask is placed on the board top side over each via to resist solder flow into the via. The mask on the top side also minimizes outgassing during the solder reflow process.

### Note

29. Source for recommendations: [EZ-USB FX2™ PCB Design Recommendations](#).

Figure 21 displays a cross-sectional area underneath the package. The cross section is of only one via. The solder paste template needs to be designed to enable at least 50% solder coverage. The thickness of the solder paste template should be 5 mil. It is recommended that 'No Clean' type 3 solder paste is used for mounting the part. Nitrogen purge is recommended during reflow.

Figure 22 is a plot of the solder mask pattern and Figure 23 displays an X-Ray image of the assembly (darker areas indicate solder).

**Figure 21. Cross-section of the Area Underneath the QFN Package.**

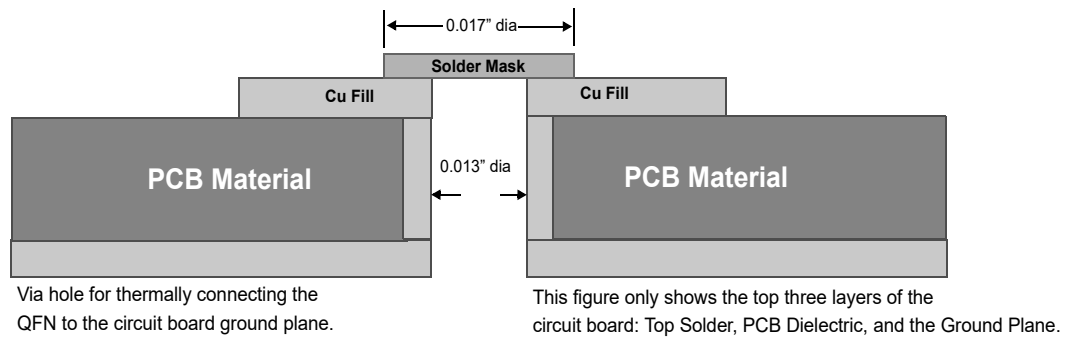

**Figure 22. Plot of the Solder Mask (White Area)**

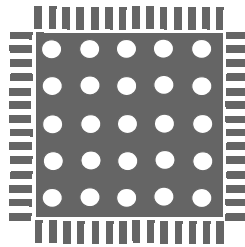

**Figure 23. X-ray Image of the Assembly**

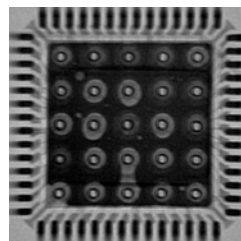

## Acronyms

Acronym	Description
ASIC	application specific integrated circuit
CPU	central processing unit
DSP	digital signal processor
ECC	error correcting codes
EEPROM	electrically erasable programmable read only memory
FIFO	first in first out
GPIF	general programmable interface
GPIO	general purpose input/output
I/O	input/output
LAN	local area network
LSB	least-significant bit
MSB	most-significant bit
PLL	phase locked loop
PCB	printed circuit board
PSoC	programmable system-on-chip
QFN	quad flat no leads
RAM	random access memory
ROM	read only memory
SCL	serial clock
SDA	serial data line
SIE	serial interface engine
USB	universal serial bus

## Document Conventions

### Units of Measure

Symbol	Unit of Measure
°C	degree Celsius
kHz	kilohertz
MHz	megahertz
μA	microampere
μs	microsecond
μW	microwatt
mA	milliampere
mm	millimeter
ms	millisecond
mV	millivolt
mW	milliwatt
ns	nanosecond
Ω	ohms
%	percent
pF	picofarad
ppm	parts per million
V	volt

## Document History Page

Document Title: CY7C68033/CY7C68034, EZ-USB <sup>®</sup> NX2LP-Flex <sup>™</sup> Flexible USB NAND Flash Controller				
Document Number: 001-04247				
Rev.	ECN No.	Orig. of Change	Submission Date	Description of Change
**	388499	GIR	08/04/2005	New data sheet (Preliminary Draft).
*A	394699	XUT	08/31/2005	Minor Change: Post to external web. Publicly announcing the parts.
*B	400518	GIR	10/06/2005	Changed status from Preliminary to Final. Updated <a href="#">CY7C68033/CY7C68034 Silicon Features</a> : Replaced "USB 2.0–USB-IF high-speed certification pending" with "Certified compliant for Bus- or Self-powered USB 2.0 operation (TID# 40490118)". Updated <a href="#">Applications</a> : Fixed typo (Corrected caption of <a href="#">Figure 2</a> ). Updated to new template.
*C	433952	RGL	03/21/2006	Added I <sup>2</sup> C functionality related information in all instances across the document.
*D	498295	KKU	08/31/2006	Replaced IO with I/O in all instances across the document. Replaced set-up with setup in all instances across the document. Updated <a href="#">Pin Assignments</a> : Updated <a href="#">Figure 9</a> (Replaced IFCLK and CLKOUT pins with GPIO8 and GPIO9 and removed external IFCLK). Updated <a href="#">AC Electrical Characteristics</a> : Removed "GPIF Synchronous Signals". Removed "Slave FIFO Synchronous Read". Removed "Slave FIFO Synchronous Write". Removed "Slave FIFO Synchronous Packet End Strobe". Removed "Slave FIFO Synchronous Address". Updated <a href="#">Sequence Diagram</a> : Removed "Single and Burst Synchronous Read Example". Removed "Single and Burst Synchronous Write". Updated to new template.
*E	2717536	DPT	06/11/2009	Updated <a href="#">Ordering Information</a> : Updated part numbers. Updated <a href="#">Package Diagrams</a> : spec 51-85144 – Changed revision from *E to *G. Added spec 001-53450 **. Updated to new template.
*F	2728424	GNKK	07/02/2009	Minor Change: Updated revision in the footer across the document.
*G	2896281	ODC	03/19/2010	Updated <a href="#">Ordering Information</a> : Updated part numbers. Updated <a href="#">Package Diagrams</a> : spec 51-85144 – Changed revision from *G to *H. spec 001-53450 – Changed revision from ** to *B. Updated to new template.
*H	2933818	SHAH / AESA	05/18/2010	Updated <a href="#">Default NAND Firmware Features</a> : Updated details under "NAND sizes supported per chip select". Added <a href="#">Acronyms</a> . Formatted table footnotes across the document (Changed to Notes).
*I	3349690	ODC	08/25/2011	Updated <a href="#">Package Diagrams</a> : Removed spec 51-85144 *H. Added <a href="#">Units of Measure</a> . Updated to new template. Completing Sunset Review.

**Document History Page** *(continued)*

Document Title: CY7C68033/CY7C68034, EZ-USB® NX2LP-Flex™ Flexible USB NAND Flash Controller Document Number: 001-04247				
Rev.	ECN No.	Orig. of Change	Submission Date	Description of Change
*J	3668026	GAYA	07/06/2012	Updated <a href="#">Ordering Information</a> : Updated part numbers. Completing Sunset Review.
*K	3711000	GAYA	08/13/2012	Updated <a href="#">Absolute Maximum Ratings</a> : Added Industrial Temperature Range related information. Updated <a href="#">Operating Conditions</a> : Added Industrial Temperature Range related information.
*L	4505623	GAYA	09/23/2014	Updated <a href="#">Default NAND Firmware Features</a> : Updated details under "Industry-standard ECC NAND flash correction". Updated <a href="#">Package Diagrams</a> : spec 001-53450 – Changed revision from *B to *D.
*M	4612073	GAYA	01/12/2015	Updated <a href="#">Pin Assignments</a> : Updated <a href="#">Figure 9</a> . Updated <a href="#">Table 8</a> : Updated details in "Default Pin Name" column corresponding to 56-pin QFN Pin Number 54 and 13. Updated to new template.
*N	4928521	GAYA	09/21/2015	No technical updates. Completing Sunset Review.
*O	5755453	HARA	05/30/2017	Updated Cypress Logo and Copyright.
*P	6339210	ANNR	10/09/2018	Updated to new template. Completing Sunset Review.
*Q	6565692	ANNR	05/03/2019	Updated <a href="#">Functional Overview</a> : Updated <a href="#">Interrupt System</a> : Updated <a href="#">INT2 Interrupt Request and Enable Registers</a> : Updated hyperlinks. Updated <a href="#">Reset and Wakeup</a> : Updated <a href="#">Reset Pin</a> : Updated description. Updated <a href="#">Ordering Information</a> : Updated part numbers. Updated <a href="#">Package Diagrams</a> : spec 001-53450 – Changed revision from *D to *E. Updated <a href="#">PCB Layout Recommendations</a> : Updated Note 29. Updated <a href="#">Quad Flat Package No Leads (QFN) Package Design Notes</a> : Updated description. Updated to new template.

## Sales, Solutions, and Legal Information

### Worldwide Sales and Design Support

Cypress maintains a worldwide network of offices, solution centers, manufacturer's representatives, and distributors. To find the office closest to you, visit us at [Cypress Locations](#).

#### Products

Arm <sup>®</sup> Cortex <sup>®</sup> Microcontrollers	<a href="http://cypress.com/arm">cypress.com/arm</a>
Automotive	<a href="http://cypress.com/automotive">cypress.com/automotive</a>
Clocks & Buffers	<a href="http://cypress.com/clocks">cypress.com/clocks</a>
Interface	<a href="http://cypress.com/interface">cypress.com/interface</a>
Internet of Things	<a href="http://cypress.com/iot">cypress.com/iot</a>
Memory	<a href="http://cypress.com/memory">cypress.com/memory</a>
Microcontrollers	<a href="http://cypress.com/mcu">cypress.com/mcu</a>
PSoC	<a href="http://cypress.com/psoc">cypress.com/psoc</a>
Power Management ICs	<a href="http://cypress.com/pmic">cypress.com/pmic</a>
Touch Sensing	<a href="http://cypress.com/touch">cypress.com/touch</a>
USB Controllers	<a href="http://cypress.com/usb">cypress.com/usb</a>
Wireless Connectivity	<a href="http://cypress.com/wireless">cypress.com/wireless</a>

#### PSoC<sup>®</sup> Solutions

[PSoC 1](#) | [PSoC 3](#) | [PSoC 4](#) | [PSoC 5LP](#) | [PSoC 6 MCU](#)

#### Cypress Developer Community

[Community](#) | [Projects](#) | [Video](#) | [Blogs](#) | [Training](#) | [Components](#)

#### Technical Support

[cypress.com/support](http://cypress.com/support)



© Cypress Semiconductor Corporation, 2005–2019. This document is the property of Cypress Semiconductor Corporation and its subsidiaries ("Cypress"). This document, including any software or firmware included or referenced in this document ("Software"), is owned by Cypress under the intellectual property laws and treaties of the United States and other countries worldwide. Cypress reserves all rights under such laws and treaties and does not, except as specifically stated in this paragraph, grant any license under its patents, copyrights, trademarks, or other intellectual property rights. If the Software is not accompanied by a license agreement and you do not otherwise have a written agreement with Cypress governing the use of the Software, then Cypress hereby grants you a personal, non-exclusive, nontransferable license (without the right to sublicense) (1) under its copyright rights in the Software (a) for Software provided in source code form, to modify and reproduce the Software solely for use with Cypress hardware products, only internally within your organization, and (b) to distribute the Software in binary code form externally to end users (either directly or indirectly through resellers and distributors), solely for use on Cypress hardware product units, and (2) under those claims of Cypress's patents that are infringed by the Software (as provided by Cypress, unmodified) to make, use, distribute, and import the Software solely for use with Cypress hardware products. Any other use, reproduction, modification, translation, or compilation of the Software is prohibited.

TO THE EXTENT PERMITTED BY APPLICABLE LAW, CYPRESS MAKES NO WARRANTY OF ANY KIND, EXPRESS OR IMPLIED, WITH REGARD TO THIS DOCUMENT OR ANY SOFTWARE OR ACCOMPANYING HARDWARE, INCLUDING, BUT NOT LIMITED TO, THE IMPLIED WARRANTIES OF MERCHANTABILITY AND FITNESS FOR A PARTICULAR PURPOSE. No computing device can be absolutely secure. Therefore, despite security measures implemented in Cypress hardware or software products, Cypress shall have no liability arising out of any security breach, such as unauthorized access to or use of a Cypress product. CYPRESS DOES NOT REPRESENT, WARRANT, OR GUARANTEE THAT CYPRESS PRODUCTS, OR SYSTEMS CREATED USING CYPRESS PRODUCTS, WILL BE FREE FROM CORRUPTION, ATTACK, VIRUSES, INTERFERENCE, HACKING, DATA LOSS OR THEFT, OR OTHER SECURITY INTRUSION (collectively, "Security Breach"). Cypress disclaims any liability relating to any Security Breach, and you shall and hereby do release Cypress from any claim, damage, or other liability arising from any Security Breach. In addition, the products described in these materials may contain design defects or errors known as errata which may cause the product to deviate from published specifications. To the extent permitted by applicable law, Cypress reserves the right to make changes to this document without further notice. Cypress does not assume any liability arising out of the application or use of any product or circuit described in this document. Any information provided in this document, including any sample design information or programming code, is provided only for reference purposes. It is the responsibility of the user of this document to properly design, program, and test the functionality and safety of any application made of this information and any resulting product. "High-Risk Device" means any device or system whose failure could cause personal injury, death, or property damage. Examples of High-Risk Devices are weapons, nuclear installations, surgical implants, and other medical devices. "Critical Component" means any component of a High-Risk Device whose failure to perform can be reasonably expected to cause, directly or indirectly, the failure of the High-Risk Device, or to affect its safety or effectiveness. Cypress is not liable, in whole or in part, and you shall and hereby do release Cypress from any claim, damage, or other liability arising from any use of a Cypress product as a Critical Component in a High-Risk Device. You shall indemnify and hold Cypress, its directors, officers, employees, agents, affiliates, distributors, and assigns harmless from and against all claims, costs, damages, and expenses, arising out of any claim, including claims for product liability, personal injury or death, or property damage arising from any use of a Cypress product as a Critical Component in a High-Risk Device. Cypress products are not intended or authorized for use as a Critical Component in any High-Risk Device except to the limited extent that (i) Cypress's published data sheet for the product explicitly states Cypress has qualified the product for use in a specific High-Risk Device, or (ii) Cypress has given you advance written authorization to use the product as a Critical Component in the specific High-Risk Device and you have signed a separate indemnification agreement.

Cypress, the Cypress logo, Spansion, the Spansion logo, and combinations thereof, WICED, PSoC, CapSense, EZ-USB, F-RAM, and Traveo are trademarks or registered trademarks of Cypress in the United States and other countries. For a more complete list of Cypress trademarks, visit [cypress.com](http://cypress.com). Other names and brands may be claimed as property of their respective owners.

## Looking for pricing, stock, or lifecycle information?

Click below to explore more details on WIN SOURCE:

-  [View CY7C68033-56LFXC on WIN SOURCE](#)
-  [Cypress Semiconductor Corp Information](#)

## Optimize Your Supply Chain with WIN SOURCE Solutions

-  Global Sourcing Solution
-  Obsolete Management
-  Cost Control Management
-  Shortage Management
-  Alternative Solution
-  Excess Inventory Management