



# THE DATASHEET OF SN74HCT257DRE4



## Quadruple 2-Line to 1-Line Data Select RS/Multiplexers With 3-State Outputs

### 1 Features

- Operating voltage range of 4.5 V to 5.5 V
- High-current 3-state outputs interface directly with system bus
- Typical  $t_{pd} = 17$  ns
- Low power consumption, 80- $\mu$ A max  $I_{CC}$
- $\pm 6$ -mA output drive at 5 V
- Low input current of 1  $\mu$ A max
- Inputs are TTL-voltage compatible
- Provide bus interface from multiple sources in high-performance systems
- Buffered inputs and outputs

### 2 Description

The 'HCT257 devices are designed to multiplex signals from 4-bit data sources to 4-output data lines in bus-organized systems.

#### Device Information

ORDERABLE PART NUMBER	PACKAGE	BODY SIZE (NOM)
SN74HCT257	N (PDIP, 16)	19.31 mm $\times$ 6.35 mm
	D (SOIC, 16)	9.90 mm $\times$ 3.90 mm
SNJ54HCT257	J (CDIP, 16)	24.38 mm $\times$ 6.92 mm

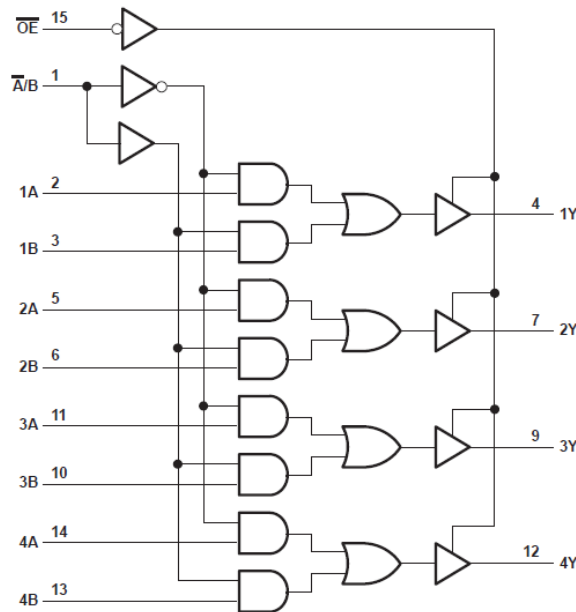

A. Pin numbers shown are for the D, J, and N packages.

#### Logic Diagram (Positive Logic)

## Table of Contents

<b>1 Features</b> .....	<b>1</b>	<b>8 Device Functional Modes</b> .....	<b>9</b>
<b>2 Description</b> .....	<b>1</b>	<b>9 Power Supply Recommendations</b> .....	<b>10</b>
<b>3 Revision History</b> .....	<b>2</b>	<b>10 Layout</b> .....	<b>10</b>
<b>4 Pin Configuration and Functions</b> .....	<b>3</b>	10.1 Layout Guidelines.....	<b>10</b>
<b>5 Specifications</b> .....	<b>4</b>	<b>11 Device and Documentation Support</b> .....	<b>11</b>
5.1 Absolute Maximum Ratings .....	<b>4</b>	11.1 Documentation Support.....	<b>11</b>
5.2 Recommended Operating Conditions <sup>(1)</sup> .....	<b>4</b>	11.2 Receiving Notification of Documentation Updates..	<b>11</b>
5.3 Thermal Information.....	<b>4</b>	11.3 Support Resources.....	<b>11</b>
5.4 Electrical Characteristics.....	<b>4</b>	11.4 Trademarks.....	<b>11</b>
5.5 Switching Characteristics .....	<b>5</b>	11.5 Electrostatic Discharge Caution.....	<b>11</b>
5.6 Switching Characteristics.....	<b>5</b>	11.6 Glossary.....	<b>11</b>
5.7 Operating Characteristics.....	<b>6</b>	<b>12 Mechanical, Packaging, and Orderable</b>	
<b>6 Parameter Measurement Information</b> .....	<b>7</b>	<b>Information</b> .....	<b>11</b>
<b>7 Detailed Description</b> .....	<b>8</b>	12.1 Tape and Reel Information.....	<b>12</b>
7.1 Overview.....	<b>8</b>	12.2 Mechanical Data.....	<b>13</b>
7.2 Functional Block Diagram.....	<b>8</b>		

### 3 Revision History

NOTE: Page numbers for previous revisions may differ from page numbers in the current version.

<b>Changes from Revision D (September 2003) to Revision E (July 2022)</b>	<b>Page</b>
• Updated the numbering, formatting, tables, figures, and cross-references throughout the document to reflect modern data sheet standards.....	<b>1</b>

## 4 Pin Configuration and Functions

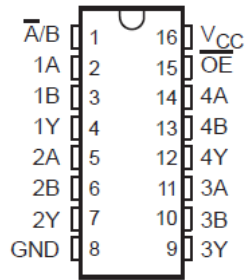

**Figure 4-1. J, N and D Package  
16-Pin CDIP, PDIP or SOIC  
Top View**

### Pin Functions

PIN		I/O <sup>(1)</sup>	DESCRIPTION
SOIC or TSSOP NO.	NAME		
1	$\bar{A}/B$	I	Address select
2	1A	I	Channel 1, data input A
3	1B	I	Channel 1, data input B
4	1Y	I	Channel 1, data output
5	2A	O	Channel 2, data input A
6	2B	O	Channel 2, data input B
7	2Y	I	Channel 2, data output
8	GND	—	Ground
9	3Y	I	Channel 3, data output
10	3B	I	Channel 3, data input B
11	3A	I	Channel 3, data input A
12	4Y	I	Channel 4, data output
13	4B	I	Channel 4, data input B
14	4A	I	Channel 4, data input A
15	$\bar{G}$	I	Output strobe, active low
16	V <sub>CC</sub>	—	Positive supply

## 5 Specifications

### 5.1 Absolute Maximum Ratings

over operating free-air temperature range (unless otherwise noted)<sup>(1)</sup>

		MIN	MAX	UNIT
V <sub>CC</sub>	Supply voltage range	-0.5	7	V
I <sub>IK</sub>	Input clamp current <sup>(2)</sup>	V <sub>I</sub> < 0 or V <sub>I</sub> > V <sub>CC</sub>	±20	mA
I <sub>OK</sub>	Output clamp current <sup>(2)</sup>	V <sub>O</sub> < 0 or V <sub>O</sub> > V <sub>CC</sub>	±20	mA
I <sub>O</sub>	Continuous output current	V <sub>O</sub> = 0 to V <sub>CC</sub>	±35	mA
	Continuous current through V <sub>CC</sub> or GND		±70	mA
T <sub>J</sub>	Junction Temperature		150	°C
T <sub>stg</sub>	Storage temperature range	-65	150	°C

- (1) Stresses beyond those listed under “absolute maximum ratings” may cause permanent damage to the device. These are stress ratings only, and functional operation of the device at these or any other conditions beyond those indicated under “recommended operating conditions” is not implied. Exposure to absolute-maximum-rated conditions for extended periods may affect device reliability.
- (2) The input and output voltage ratings may be exceeded if the input and output current ratings are observed.

### 5.2 Recommended Operating Conditions<sup>(1)</sup>

		SN54HCT257			SN74HCT257			UNIT
		MIN	NOM	MAX	MIN	NOM	MAX	
V <sub>CC</sub>	Supply voltage	4.5	5	5.5	4.5	5	5.5	V
V <sub>IH</sub>	High-level input voltage	V <sub>CC</sub> = 4.5 V to 5.5 V		2	2			V
V <sub>IL</sub>	Low-level input voltage	V <sub>CC</sub> = 4.5 V to 5.5 V		0.8	0.8			V
V <sub>I</sub>	Input voltage	0	V <sub>CC</sub>		0	V <sub>CC</sub>		V
V <sub>O</sub>	Output voltage	0	V <sub>CC</sub>		0	V <sub>CC</sub>		V
t <sub>t</sub>	Input transition (rise and fall) time			500	500			ns
T <sub>A</sub>	Operating free-air temperature	-55	125		-40	85		°C

- (1) All unused inputs of the device must be held at V<sub>CC</sub> or GND to ensure proper device operation. Refer to the TI application report, *Implications of Slow or Floating CMOS Inputs*, literature number [SCBA004](#).

### 5.3 Thermal Information

THERMAL METRIC		D (SOIC)	N (PDIP)	UNIT
		16 PINS	16 PINS	
R <sub>θJA</sub>	Package thermal impedance	73	67	°C/W

### 5.4 Electrical Characteristics

over recommended operating free-air temperature range (unless otherwise noted)

PARAMETER		TEST CONDITIONS		V <sub>CC</sub>	T <sub>A</sub> = 25°C			SN54HCT257		SN74HCT257		UNIT
					MIN	TYP	MAX	MIN	MAX	MIN	MAX	
V <sub>OH</sub>	High level output voltage	V <sub>I</sub> = V <sub>IH</sub> or V <sub>IL</sub>	I <sub>OH</sub> = -20 μA	4.5 V	4.4	4.499		4.4		4.4	V	
					3.98	4.3		3.7		3.84		
V <sub>OL</sub>	L Low level output voltage	V <sub>I</sub> = V <sub>IH</sub> or V <sub>IL</sub>	I <sub>OL</sub> = 20 μA	4.5 V	0.001	0.1		0.1		0.1	V	
					0.17	0.26		0.4		0.33		

## 5.4 Electrical Characteristics (continued)

over recommended operating free-air temperature range (unless otherwise noted)

PARAMETER	TEST CONDITIONS	V <sub>CC</sub>	T <sub>A</sub> = 25°C			SN54HCT257		SN74HCT257		UNIT
			MIN	TYP	MAX	MIN	MAX	MIN	MAX	
I <sub>I</sub>	Input leakage current	V <sub>I</sub> = V <sub>CC</sub> or 0	5.5 V	±0.1	±100		±1000	±1000	nA	
I <sub>oz</sub>	Off-State (High-Impedance State) Output Current	V <sub>O</sub> = V <sub>CC</sub> or 0, V <sub>I</sub> = V <sub>IH</sub> or V <sub>IL</sub>	5.5 V	±0.01	±0.5		±10	±5	μA	
I <sub>CC</sub>	Supply current	V <sub>I</sub> = V <sub>CC</sub> or 0, I <sub>O</sub> = 0	5.5 V		8		160	80	μA	
ΔI <sub>CC</sub> <sup>(2)</sup>	Supply-Current Change	One input at 0.5 V or 2.4 V, Other inputs at 0 or V <sub>CC</sub>	5.5 V	1.4	2.4		3	2.9	mA	
C <sub>i</sub>	Input Capacitance		4.5 V to 5.5 V	3	10		10 <sup>(1)</sup>	10	pF	

(1) On products compliant to MIL-PRF-38535, this parameter is not production tested.

(2) This is the increase in supply current for each input that is at one of the specified TTL voltage levels, rather than 0 V or V<sub>CC</sub>.

## 5.5 Switching Characteristics

over recommended operating free-air temperature range, C<sub>L</sub> = 50 pF (unless otherwise noted) (see [Figure 6-1](#))

PARAMETER	FROM (INPUT)	TO (OUTPUT)	V <sub>CC</sub>	T <sub>A</sub> = 25°C			SN54HCT257		SN74HCT257		UNIT
				MIN	TYP	MAX	MIN	MAX	MIN	MAX	
t <sub>pd</sub>	A or B	Y	4.5 V		20	30		45		38	ns
			5.5 V		17	27		40		34	
	A̅/B	Y	4.5 V		20	30		45		38	
			5.5 V		17	27		40		34	
t <sub>en</sub>	OE̅	Y	4.5 V		20	30		45		38	ns
			5.5 V		17	27		40		34	
t <sub>dis</sub>	OE̅	Y	4.5 V		20	30		45		38	ns
			5.5 V		17	27		40		34	
t <sub>t</sub>		Any	4.5 V		8	15		22		19	ns
			5.5 V		7	14		21		17	

## 5.6 Switching Characteristics

over recommended operating free-air temperature range, C<sub>L</sub> = 150 pF (unless otherwise noted) (see [Figure 6-1](#))

PARAMETER	FROM (INPUT)	TO (OUTPUT)	V <sub>C</sub>	T <sub>A</sub> = 25°C			SN54HCT257		SN74HCT257		UNIT
				MIN	TYP	MAX	MIN	MAX	MIN	MAX	
t <sub>pd</sub>	A or B	Y	4.5 V		22	38		57		48	ns
			5.5 V		19	35		53		44	
	A̅/B	Y	4.5 V		22	38		57		48	
			5.5 V		19	35		53		44	
t <sub>en</sub>	OE̅	Y	4.5 V		23	40		60		50	ns
			5.5 V		20	38		57		48	
t <sub>t</sub>		Any	4.5 V		17	42		63		53	ns
			5.5 V		14	38		57		48	

## 5.7 Operating Characteristics

 $T_A$  25°C

PARAMETER		TEST CONDITIONS	TYP	UNIT
$C_{pd}$	Power dissipation capacitance	No load	13	pF

## 6 Parameter Measurement Information

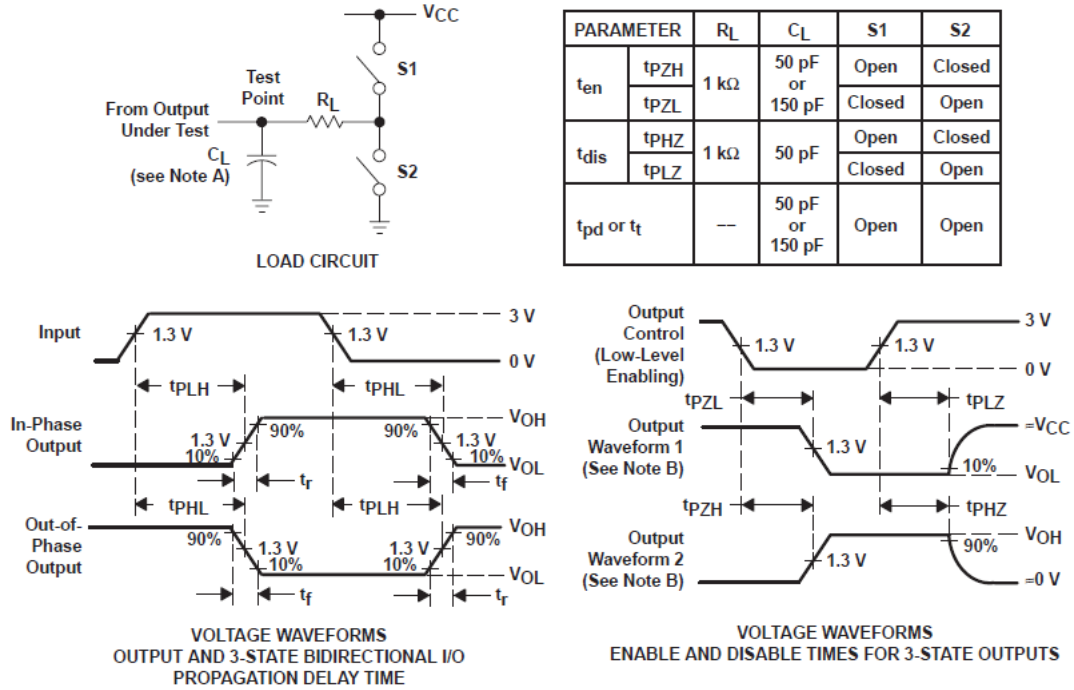

- A.  $C_L$  includes probe and test-fixture capacitance.
- B. Waveform 1 is for an output with internal conditions such that the output is low except when disabled by the output control. Waveform 2 is for an output with internal conditions such that the output is high except when disabled by the output control.
- C. Phase relationships between waveforms were chosen arbitrarily. All input pulses are supplied by generators having the following characteristics:  $PRR \leq 1$  MHz,  $Z_O = 50 \Omega$ ,  $t_r = 6$  ns,  $t_f = 6$  ns.
- D. The outputs are measured one at a time with one input transition per measurement.
- E.  $t_{PLZ}$  and  $t_{PHZ}$  are the same as  $t_{dis}$ .
- F.  $t_{PZL}$  and  $t_{PZH}$  are the same as  $t_{en}$ .
- G.  $t_{PLH}$  and  $t_{PHL}$  are the same as  $t_{pd}$ .

**Figure 6-1. Load Circuit and Voltage Waveforms**

## 7 Detailed Description

### 7.1 Overview

The 'HCT257 devices are designed to multiplex signals from 4-bit data sources to 4-output data lines in bus-organized systems. The 3-state outputs do not load the data lines when the output-enable ( $\overline{OE}$ ) input is at the high logic level.

To ensure the high-impedance state during power up or power down,  $\overline{OE}$  should be tied to  $V_{CC}$  through a pullup resistor; the minimum value of the resistor is determined by the current-sinking capability of the driver.

### 7.2 Functional Block Diagram

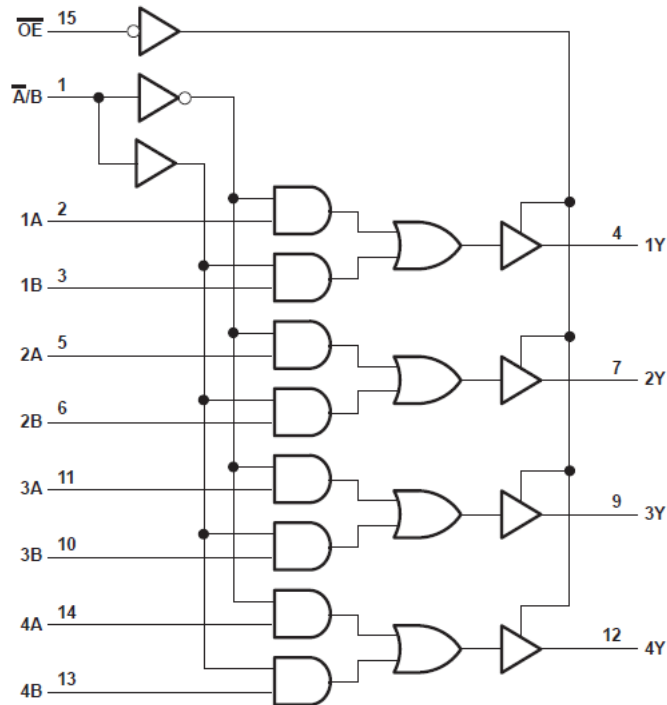

Figure 7-1. Function Diagram

## 8 Device Functional Modes

**Table 8-1. Function Table**

INPUTS <sup>(1)</sup>				OUTPUT <sup>(2)</sup> Y
OE	SELECT A/B	DATA		
		A	B	
H	X	X	X	Z
L	L	L	X	L
L	L	H	X	H
L	H	X	L	L
L	H	X	H	H

- (1) H = High Voltage Level, L = Low Voltage Level, X = Don't Care  
 (2) H = Driving High, L = Driving Low, Z = High Impedance State

## 9 Power Supply Recommendations

The power supply can be any voltage between the minimum and maximum supply voltage rating located in the *Recommended Operating Conditions*. Each  $V_{CC}$  terminal should have a good bypass capacitor to prevent power disturbance. A 0.1- $\mu\text{F}$  capacitor is recommended for this device. It is acceptable to parallel multiple bypass caps to reject different frequencies of noise. The 0.1- $\mu\text{F}$  and 1- $\mu\text{F}$  capacitors are commonly used in parallel. The bypass capacitor should be installed as close to the power terminal as possible for best results.

## 10 Layout

### 10.1 Layout Guidelines

When using multiple-input and multiple-channel logic devices inputs must not ever be left floating. In many cases, functions or parts of functions of digital logic devices are unused; for example, when only two inputs of a triple-input AND gate are used or only 3 of the 4 buffer gates are used. Such unused input pins must not be left unconnected because the undefined voltages at the outside connections result in undefined operational states. All unused inputs of digital logic devices must be connected to a logic high or logic low voltage, as defined by the input voltage specifications, to prevent them from floating. The logic level that must be applied to any particular unused input depends on the function of the device. Generally, the inputs are tied to GND or  $V_{CC}$ , whichever makes more sense for the logic function or is more convenient.

## 11 Device and Documentation Support

TI offers an extensive line of development tools. Tools and software to evaluate the performance of the device, generate code, and develop solutions are listed below.

### 11.1 Documentation Support

#### 11.1.1 Related Documentation

### 11.2 Receiving Notification of Documentation Updates

To receive notification of documentation updates, navigate to the device product folder on [ti.com](http://ti.com). Click on *Subscribe to updates* to register and receive a weekly digest of any product information that has changed. For change details, review the revision history included in any revised document.

### 11.3 Support Resources

[TI E2E™ support forums](#) are an engineer's go-to source for fast, verified answers and design help — straight from the experts. Search existing answers or ask your own question to get the quick design help you need.

Linked content is provided "AS IS" by the respective contributors. They do not constitute TI specifications and do not necessarily reflect TI's views; see TI's [Terms of Use](#).

### 11.4 Trademarks

TI E2E™ is a trademark of Texas Instruments.  
All trademarks are the property of their respective owners.

### 11.5 Electrostatic Discharge Caution



This integrated circuit can be damaged by ESD. Texas Instruments recommends that all integrated circuits be handled with appropriate precautions. Failure to observe proper handling and installation procedures can cause damage.

ESD damage can range from subtle performance degradation to complete device failure. Precision integrated circuits may be more susceptible to damage because very small parametric changes could cause the device not to meet its published specifications.

### 11.6 Glossary

[TI Glossary](#) This glossary lists and explains terms, acronyms, and definitions.

## 12 Mechanical, Packaging, and Orderable Information

The following pages include mechanical, packaging, and orderable information. This information is the most current data available for the designated devices. This data is subject to change without notice and revision of this document. For browser-based versions of this data sheet, refer to the left-hand navigation.

### 12.1 Tape and Reel Information

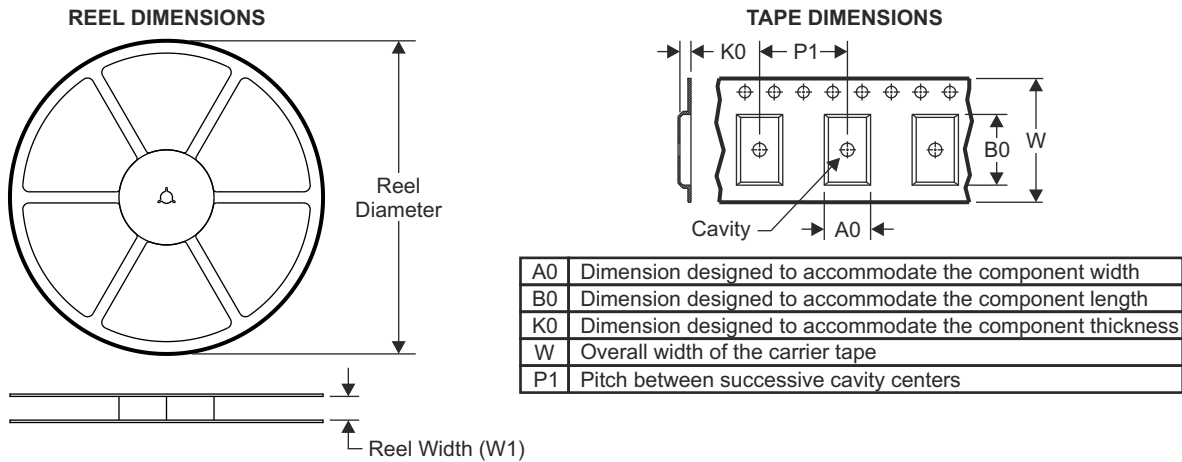

#### QUADRANT ASSIGNMENTS FOR PIN 1 ORIENTATION IN TAPE

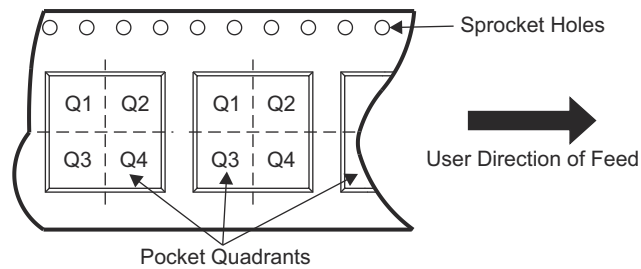

Device	Package Type	Package Drawing	Pins	SPQ	Reel Diameter (mm)	Reel Width W1 (mm)	A0 (mm)	B0 (mm)	K0 (mm)	P1 (mm)	W (mm)	Pin1 Quadrant

#### TAPE AND REEL BOX DIMENSIONS

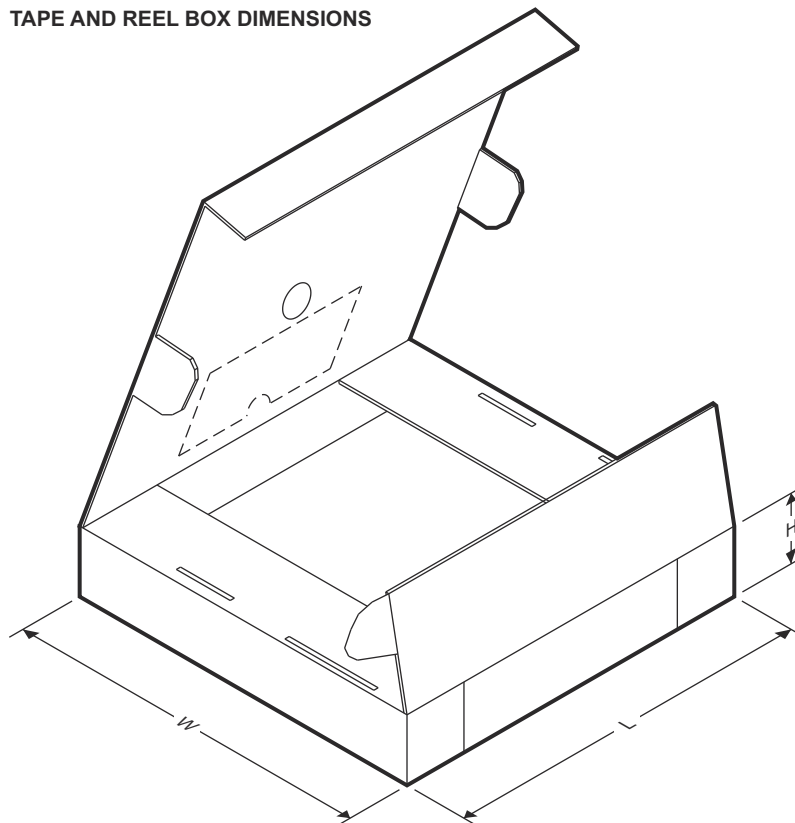

Device	Package Type	Package Drawing	Pins	SPQ	Length (mm)	Width (mm)	Height (mm)
--------	--------------	-----------------	------	-----	-------------	------------	-------------

## 12.2 Mechanical Data

**PACKAGING INFORMATION**

Orderable Device	Status (1)	Package Type	Package Drawing	Pins	Package Qty	Eco Plan (2)	Lead finish/ Ball material (6)	MSL Peak Temp (3)	Op Temp (°C)	Device Marking (4/5)	Samples
SN74HCT257DR	ACTIVE	SOIC	D	16	2500	RoHS & Green	NIPDAU   SN	Level-1-260C-UNLIM	-40 to 85	HCT257	<a href="#">Samples</a>
SN74HCT257N	ACTIVE	PDIP	N	16	25	RoHS & Green	NIPDAU	N / A for Pkg Type	-40 to 85	SN74HCT257N	<a href="#">Samples</a>

(1) The marketing status values are defined as follows:

**ACTIVE:** Product device recommended for new designs.

**LIFEBUY:** TI has announced that the device will be discontinued, and a lifetime-buy period is in effect.

**NRND:** Not recommended for new designs. Device is in production to support existing customers, but TI does not recommend using this part in a new design.

**PREVIEW:** Device has been announced but is not in production. Samples may or may not be available.

**OBSOLETE:** TI has discontinued the production of the device.

(2) **RoHS:** TI defines "RoHS" to mean semiconductor products that are compliant with the current EU RoHS requirements for all 10 RoHS substances, including the requirement that RoHS substance do not exceed 0.1% by weight in homogeneous materials. Where designed to be soldered at high temperatures, "RoHS" products are suitable for use in specified lead-free processes. TI may reference these types of products as "Pb-Free".

**RoHS Exempt:** TI defines "RoHS Exempt" to mean products that contain lead but are compliant with EU RoHS pursuant to a specific EU RoHS exemption.

**Green:** TI defines "Green" to mean the content of Chlorine (Cl) and Bromine (Br) based flame retardants meet JS709B low halogen requirements of <=1000ppm threshold. Antimony trioxide based flame retardants must also meet the <=1000ppm threshold requirement.

(3) MSL, Peak Temp. - The Moisture Sensitivity Level rating according to the JEDEC industry standard classifications, and peak solder temperature.

(4) There may be additional marking, which relates to the logo, the lot trace code information, or the environmental category on the device.

(5) Multiple Device Markings will be inside parentheses. Only one Device Marking contained in parentheses and separated by a "~" will appear on a device. If a line is indented then it is a continuation of the previous line and the two combined represent the entire Device Marking for that device.

(6) Lead finish/Ball material - Orderable Devices may have multiple material finish options. Finish options are separated by a vertical ruled line. Lead finish/Ball material values may wrap to two lines if the finish value exceeds the maximum column width.

**Important Information and Disclaimer:**The information provided on this page represents TI's knowledge and belief as of the date that it is provided. TI bases its knowledge and belief on information provided by third parties, and makes no representation or warranty as to the accuracy of such information. Efforts are underway to better integrate information from third parties. TI has taken and continues to take reasonable steps to provide representative and accurate information but may not have conducted destructive testing or chemical analysis on incoming materials and chemicals. TI and TI suppliers consider certain information to be proprietary, and thus CAS numbers and other limited information may not be available for release.

In no event shall TI's liability arising out of such information exceed the total purchase price of the TI part(s) at issue in this document sold by TI to Customer on an annual basis.



## TAPE AND REEL INFORMATION



### QUADRANT ASSIGNMENTS FOR PIN 1 ORIENTATION IN TAPE



\*All dimensions are nominal

Device	Package Type	Package Drawing	Pins	SPQ	Reel Diameter (mm)	Reel Width W1 (mm)	A0 (mm)	B0 (mm)	K0 (mm)	P1 (mm)	W (mm)	Pin1 Quadrant
SN74HCT257DR	SOIC	D	16	2500	330.0	16.4	6.6	9.3	2.1	8.0	16.0	Q1
SN74HCT257DR	SOIC	D	16	2500	330.0	16.4	6.5	10.3	2.1	8.0	16.0	Q1

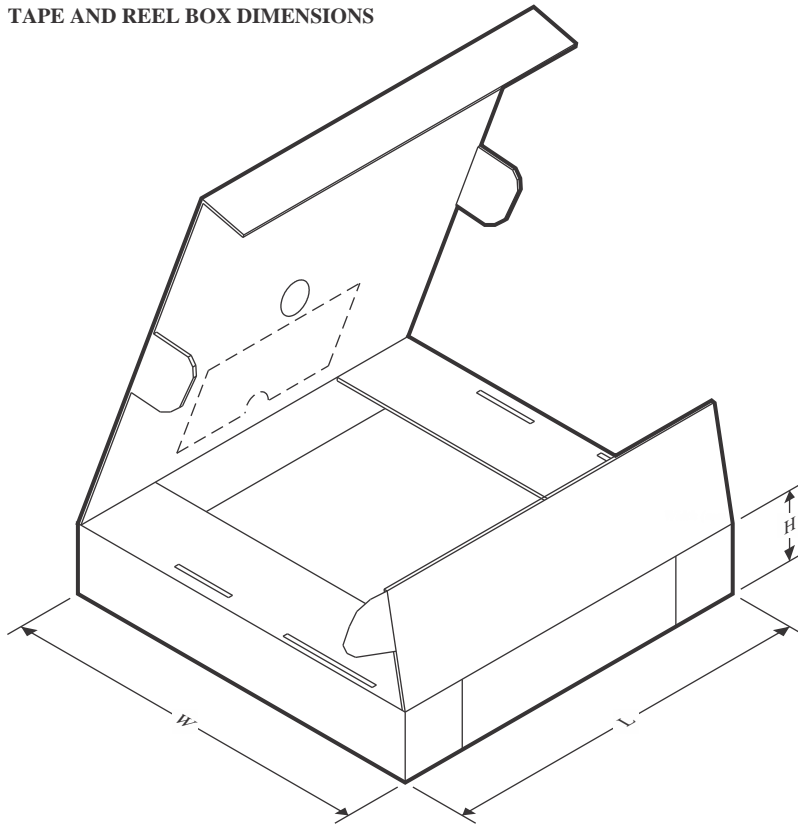
**TAPE AND REEL BOX DIMENSIONS**

\*All dimensions are nominal

Device	Package Type	Package Drawing	Pins	SPQ	Length (mm)	Width (mm)	Height (mm)
SN74HCT257DR	SOIC	D	16	2500	366.0	364.0	50.0
SN74HCT257DR	SOIC	D	16	2500	356.0	356.0	35.0

**TUBE**

\*All dimensions are nominal



Device	Package Name	Package Type	Pins	SPQ	L (mm)	W (mm)	T (μm)	B (mm)
SN74HCT257N	N	PDIP	16	25	506	13.97	11230	4.32
SN74HCT257N	N	PDIP	16	25	506	13.97	11230	4.32

D (R-PDSO-G16)

PLASTIC SMALL OUTLINE



4040047-6/M 06/11

- NOTES:
- A. All linear dimensions are in inches (millimeters).
  - B. This drawing is subject to change without notice.
  -  C. Body length does not include mold flash, protrusions, or gate burrs. Mold flash, protrusions, or gate burrs shall not exceed 0.006 (0,15) each side.
  -  D. Body width does not include interlead flash. Interlead flash shall not exceed 0.017 (0,43) each side.
  - E. Reference JEDEC MS-012 variation AC.

N (R-PDIP-T\*\*)

PLASTIC DUAL-IN-LINE PACKAGE

16 PINS SHOWN



4040049/E 12/2002

- NOTES:
- A. All linear dimensions are in inches (millimeters).
  - B. This drawing is subject to change without notice.
  - (C) Falls within JEDEC MS-001, except 18 and 20 pin minimum body length (Dim A).
  - (D) The 20 pin end lead shoulder width is a vendor option, either half or full width.

## IMPORTANT NOTICE AND DISCLAIMER

TI PROVIDES TECHNICAL AND RELIABILITY DATA (INCLUDING DATA SHEETS), DESIGN RESOURCES (INCLUDING REFERENCE DESIGNS), APPLICATION OR OTHER DESIGN ADVICE, WEB TOOLS, SAFETY INFORMATION, AND OTHER RESOURCES "AS IS" AND WITH ALL FAULTS, AND DISCLAIMS ALL WARRANTIES, EXPRESS AND IMPLIED, INCLUDING WITHOUT LIMITATION ANY IMPLIED WARRANTIES OF MERCHANTABILITY, FITNESS FOR A PARTICULAR PURPOSE OR NON-INFRINGEMENT OF THIRD PARTY INTELLECTUAL PROPERTY RIGHTS.

These resources are intended for skilled developers designing with TI products. You are solely responsible for (1) selecting the appropriate TI products for your application, (2) designing, validating and testing your application, and (3) ensuring your application meets applicable standards, and any other safety, security, regulatory or other requirements.

These resources are subject to change without notice. TI grants you permission to use these resources only for development of an application that uses the TI products described in the resource. Other reproduction and display of these resources is prohibited. No license is granted to any other TI intellectual property right or to any third party intellectual property right. TI disclaims responsibility for, and you will fully indemnify TI and its representatives against, any claims, damages, costs, losses, and liabilities arising out of your use of these resources.

TI's products are provided subject to [TI's Terms of Sale](#) or other applicable terms available either on [ti.com](https://www.ti.com) or provided in conjunction with such TI products. TI's provision of these resources does not expand or otherwise alter TI's applicable warranties or warranty disclaimers for TI products.

TI objects to and rejects any additional or different terms you may have proposed.

Mailing Address: Texas Instruments, Post Office Box 655303, Dallas, Texas 75265  
Copyright © 2023, Texas Instruments Incorporated

## Looking for pricing, stock, or lifecycle information?

Click below to explore more details on WIN SOURCE:

 [View SN74HCT257DRE4 on WIN SOURCE](#)

 [Texas Instruments](#) Information

## Optimize Your Supply Chain with WIN SOURCE Solutions

-  Global Sourcing Solution
-  Obsolete Management
-  Cost Control Management
-  Shortage Management
-  Alternative Solution
-  Excess Inventory Management