



**THE DATASHEET OF  
SN74SSTV16857DGVRG**



**SN74SSTVF16857**  
**14-BIT REGISTERED BUFFER**  
**WITH SSTL\_2 INPUTS AND OUTPUTS**  
 SCES411B – AUGUST 2002 – REVISED APRIL 2003

- Member of the Texas Instruments Widebus™ Family
- Operates at 2.3 V to 2.7 V for PC1600, PC2100, and PC2700; 2.5 V to 2.7 V for PC3200
- Pinout and Functionality Compatible With JEDEC Standard SSTV16857
- 600 ps Faster (Simultaneous Switching) Than JEDEC Standard SSTV16857 in PC2700 DIMM Applications
- Output Edge-Control Circuitry Minimizes Switching Noise in Unterminated DIMM Load
- Outputs Meet SSTL\_2 Class I Specifications
- Supports SSTL\_2 Data Inputs
- Differential Clock (CLK and  $\overline{\text{CLK}}$ ) Inputs
- Supports LVCMOS Switching Levels on the  $\overline{\text{RESET}}$  Input
- $\overline{\text{RESET}}$  Input Disables Differential Input Receivers, Resets All Registers, and Forces All Outputs Low
- Flow-Through Architecture Optimizes PCB Layout
- Latch-Up Performance Exceeds 100 mA Per JESD 78, Class II
- ESD Protection Exceeds JESD 22
  - 2000-V Human-Body Model (A114-A)
  - 200-V Machine Model (A115-A)
  - 1000-V Charged-Device Model (C101)

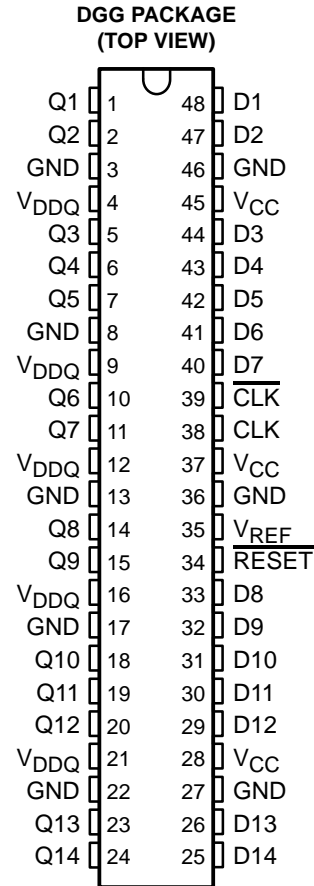

**description/ordering information**

This 14-bit registered buffer is designed for 2.3-V to 2.7-V  $V_{CC}$  operation.

All inputs are SSTL\_2, except the LVCMOS reset ( $\overline{\text{RESET}}$ ) input. All outputs are edge-controlled circuits optimized for unterminated DIMM loads and meet SSTL\_2 Class I specifications.

The SN74SSTVF16857 operates from a differential clock (CLK and  $\overline{\text{CLK}}$ ). Data are registered at the crossing of CLK going high and  $\overline{\text{CLK}}$  going low.

**ORDERING INFORMATION**

T <sub>A</sub>	PACKAGE†	ORDERABLE PART NUMBER	TOP-SIDE MARKING
0°C to 70°C	TSSOP – DGG   Tape and reel	SN74SSTVF16857GR	SSTVF16857

† Package drawings, standard packing quantities, thermal data, symbolization, and PCB design guidelines are available at [www.ti.com/sc/package](http://www.ti.com/sc/package).



Please be aware that an important notice concerning availability, standard warranty, and use in critical applications of Texas Instruments semiconductor products and disclaimers thereto appears at the end of this data sheet.

Widebus is a trademark of Texas Instruments.

PRODUCTION DATA information is current as of publication date. Products conform to specifications per the terms of Texas Instruments standard warranty. Production processing does not necessarily include testing of all parameters.



POST OFFICE BOX 655303 • DALLAS, TEXAS 75265

Copyright © 2003, Texas Instruments Incorporated

# SN74SSTVF16857

## 14-BIT REGISTERED BUFFER

### WITH SSTL 2 INPUTS AND OUTPUTS

SCES411B – AUGUST 2002 – REVISED APRIL 2003

#### description/ordering information (continued)

The device supports low-power standby operation. When  $\overline{\text{RESET}}$  is low, the differential input receivers are disabled, and undriven (floating) data, clock, and reference voltage ( $V_{\text{REF}}$ ) inputs are allowed. In addition, when  $\overline{\text{RESET}}$  is low, all registers are reset, and all outputs are forced low. The LVCMOS  $\overline{\text{RESET}}$  input always must be held at a valid logic high or low level.

To ensure defined outputs from the register before a stable clock has been supplied,  $\overline{\text{RESET}}$  must be held in the low state during power up.

FUNCTION TABLE

INPUTS				OUTPUT
$\overline{\text{RESET}}$	CLK	$\overline{\text{CLK}}$	D	Q
H	↑	↓	H	H
H	↑	↓	L	L
H	L or H	L or H	X	$Q_0$
L	X, or floating	X, or floating	X, or floating	L

#### logic diagram (positive logic)

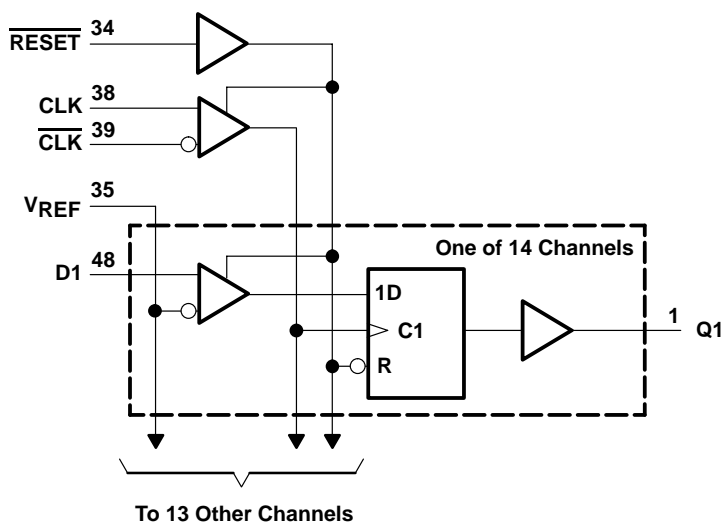

**SN74SSTVF16857**  
**14-BIT REGISTERED BUFFER**  
**WITH SSTL 2 INPUTS AND OUTPUTS**  
SCES411B – AUGUST 2002 – REVISED APRIL 2003

**absolute maximum ratings over operating free-air temperature range (unless otherwise noted)†**

Supply voltage range, $V_{CC}$ or $V_{DDQ}$ .....	-0.5 V to 3.6 V
Input voltage range, $V_I$ (see Notes 1 and 2) .....	-0.5 V to $V_{CC} + 0.5$ V
Output voltage range, $V_O$ (see Notes 1 and 2) .....	-0.5 V to $V_{DDQ} + 0.5$ V
Input clamp current, $I_{IK}$ ( $V_I < 0$ ) .....	-50 mA
Output clamp current, $I_{OK}$ ( $V_O < 0$ or $V_O > V_{DDQ}$ ) .....	±50 mA
Continuous output current, $I_O$ ( $V_O = 0$ to $V_{DDQ}$ ) .....	±50 mA
Continuous current through each $V_{CC}$ , $V_{DDQ}$ , or GND .....	±100 mA
Package thermal impedance, $\theta_{JA}$ (see Note 3) .....	70°C/W
Storage temperature range, $T_{stg}$ .....	-65°C to 150°C

† Stresses beyond those listed under “absolute maximum ratings” may cause permanent damage to the device. These are stress ratings only, and functional operation of the device at these or any other conditions beyond those indicated under “recommended operating conditions” is not implied. Exposure to absolute-maximum-rated conditions for extended periods may affect device reliability.

- NOTES: 1. The input and output negative-voltage ratings may be exceeded if the input and output clamp-current ratings are observed.  
2. This value is limited to 3.6 V maximum.  
3. The package thermal impedance is calculated in accordance with JESD 51-7.

**recommended operating conditions (see Note 4)**

		MIN	NOM	MAX	UNIT	
$V_{CC}$	Supply voltage	$V_{DDQ}$		2.7	V	
$V_{DDQ}$	Output supply voltage	PC1600, PC2100, PC2700		2.7	V	
		PC3200		2.7		
$V_{REF}$	Reference voltage ( $V_{REF} = V_{DDQ}/2$ )	PC1600, PC2100, PC2700	1.15	1.25	1.35	V
		PC3200	1.25	1.3	1.35	
$V_I$	Input voltage	0		$V_{CC}$	V	
$V_{IH}$	AC high-level input voltage	Data inputs	$V_{REF}+310$ mV		V	
$V_{IL}$	AC low-level input voltage	Data inputs	$V_{REF}-310$ mV		V	
$V_{IH}$	DC high-level input voltage	Data inputs	$V_{REF}+150$ mV		V	
$V_{IL}$	DC low-level input voltage	Data inputs	$V_{REF}-150$ mV		V	
$V_{IH}$	High-level input voltage	$\overline{RESET}$	1.7		V	
$V_{IL}$	Low-level input voltage	$\overline{RESET}$	0.7		V	
$V_{ICR}$	Common-mode input voltage range	CLK, $\overline{CLK}$	0.97		1.53	V
$V_{I(PP)}$	Peak-to-peak input voltage	CLK, $\overline{CLK}$	360		mV	
$I_{OH}$	High-level output current				-16	mA
$I_{OL}$	Low-level output current				16	mA
$T_A$	Operating free-air temperature	0			70	°C

NOTE 4: The  $\overline{RESET}$  input of the device must be held at valid logic voltage levels (not floating) to ensure proper device operation. The differential inputs must not be floating unless  $\overline{RESET}$  is low. Refer to the TI application report, *Implications of Slow or Floating CMOS Inputs*, literature number SCBA004.



# SN74SSTVF16857

## 14-BIT REGISTERED BUFFER

### WITH SSTL 2 INPUTS AND OUTPUTS

SCES411B – AUGUST 2002 – REVISED APRIL 2003

electrical characteristics for PC1600, PC2100, and PC2700 over recommended operating free-air temperature range (unless otherwise noted)

PARAMETER		TEST CONDITIONS	V <sub>CC</sub> AND V <sub>DDQ</sub>	MIN	TYP†	MAX	UNIT	
V <sub>IK</sub>		I <sub>I</sub> = -18 mA	2.3 V			-1.2	V	
V <sub>OH</sub>		I <sub>OH</sub> = -100 μA	2.3 V to 2.7 V	V <sub>DDQ</sub> -0.2			V	
		I <sub>OH</sub> = -8 mA	2.3 V	1.95				
V <sub>OL</sub>		I <sub>OL</sub> = 100 μA	2.3 V to 2.7 V			0.2	V	
		I <sub>OL</sub> = 8 mA	2.3 V			0.35		
I <sub>I</sub>	All inputs	V <sub>I</sub> = V <sub>CC</sub> or GND	2.7 V			±5	μA	
I <sub>CC</sub>	Static standby	$\overline{\text{RESET}} = \text{GND}$	2.7 V	I <sub>O</sub> = 0		10	μA	
	Static operating	$\overline{\text{RESET}} = V_{CC}$ , V <sub>I</sub> = V <sub>IH(AC)</sub> or V <sub>IL(AC)</sub>			8	25		mA
I <sub>CCD</sub>	Dynamic operating – clock only	$\overline{\text{RESET}} = V_{CC}$ , V <sub>I</sub> = V <sub>IH(AC)</sub> or V <sub>IL(AC)</sub> , CLK and $\overline{\text{CLK}}$ switching 50% duty cycle	2.5 V	I <sub>O</sub> = 0		28	μA/ MHz	
	Dynamic operating – per each data input	$\overline{\text{RESET}} = V_{CC}$ , V <sub>I</sub> = V <sub>IH(AC)</sub> or V <sub>IL(AC)</sub> , CLK and $\overline{\text{CLK}}$ switching 50% duty cycle, One data input switching at one-half clock frequency, 50% duty cycle			7	μA/ clock MHz/ D input		
C <sub>i</sub>	Data inputs	V <sub>I</sub> = V <sub>REF</sub> ± 310 mV	2.5 V		2.5	3	3.5	pF
	CLK, $\overline{\text{CLK}}$	V <sub>ICR</sub> = 1.25 V, V <sub>I(PP)</sub> = 360mV		2.5	3	3.5		
	$\overline{\text{RESET}}$	V <sub>I</sub> = V <sub>CC</sub> or GND		2.3	3	3.5		

† All typical values are at V<sub>CC</sub> = 2.5 V, T<sub>A</sub> = 25°C.

electrical characteristics for PC3200 over recommended operating free-air temperature range (unless otherwise noted)

PARAMETER		TEST CONDITIONS	V <sub>CC</sub> AND V <sub>DDQ</sub>	MIN	TYP†	MAX	UNIT	
V <sub>IK</sub>		I <sub>I</sub> = -18 mA	2.5 V			-1.2	V	
V <sub>OH</sub>		I <sub>OH</sub> = -100 μA	2.5 V to 2.7 V	V <sub>DDQ</sub> -0.2			V	
		I <sub>OH</sub> = -8 mA	2.5 V	1.95				
V <sub>OL</sub>		I <sub>OL</sub> = 100 μA	2.5 V to 2.7 V			0.2	V	
		I <sub>OL</sub> = 8 mA	2.5 V			0.35		
I <sub>I</sub>	All inputs	V <sub>I</sub> = V <sub>CC</sub> or GND	2.7 V			±5	μA	
I <sub>CC</sub>	Static standby	$\overline{\text{RESET}} = \text{GND}$	2.7 V	I <sub>O</sub> = 0		10	μA	
	Static operating	$\overline{\text{RESET}} = V_{CC}$ , V <sub>I</sub> = V <sub>IH(AC)</sub> or V <sub>IL(AC)</sub>			8	25		mA
I <sub>CCD</sub>	Dynamic operating – clock only	$\overline{\text{RESET}} = V_{CC}$ , V <sub>I</sub> = V <sub>IH(AC)</sub> or V <sub>IL(AC)</sub> , CLK and $\overline{\text{CLK}}$ switching 50% duty cycle	2.6 V	I <sub>O</sub> = 0		28	μA/ MHz	
	Dynamic operating – per each data input	$\overline{\text{RESET}} = V_{CC}$ , V <sub>I</sub> = V <sub>IH(AC)</sub> or V <sub>IL(AC)</sub> , CLK and $\overline{\text{CLK}}$ switching 50% duty cycle, One data input switching at one-half clock frequency, 50% duty cycle			7	μA/ clock MHz/ D input		
C <sub>i</sub>	Data inputs	V <sub>I</sub> = V <sub>REF</sub> ± 310 mV	2.6 V		2.5	3	3.5	pF
	CLK, $\overline{\text{CLK}}$	V <sub>ICR</sub> = 1.25 V, V <sub>I(PP)</sub> = 360mV		2.5	3	3.5		
	$\overline{\text{RESET}}$	V <sub>I</sub> = V <sub>CC</sub> or GND		2.3	3	3.5		

† All typical values are at V<sub>CC</sub> = 2.6 V, T<sub>A</sub> = 25°C.



**SN74SSTVF16857**  
**14-BIT REGISTERED BUFFER**  
**WITH SSTL 2 INPUTS AND OUTPUTS**  
 SCES411B – AUGUST 2002 – REVISED APRIL 2003

timing requirements over recommended operating free-air temperature range (unless otherwise noted) (see Figure 1)

			$V_{CC} = 2.5\text{ V} \pm 0.2\text{ V}^\dagger$		$V_{CC} = 2.6\text{ V} \pm 0.1\text{ V}^\dagger$		UNIT
			MIN	MAX	MIN	MAX	
$f_{\text{clock}}$	Clock frequency		250		250		MHz
$t_w$	Pulse duration, CLK, $\overline{\text{CLK}}$ high or low		2		2		ns
$t_{\text{act}}$	Differential inputs active time (see Note 5)		22		22		ns
$t_{\text{inact}}$	Differential inputs inactive time (see Note 6)		22		22		ns
$t_{\text{su}}$	Setup time	Fast slew rate (see Notes 7 and 9)	Data before CLK $\uparrow$ , $\overline{\text{CLK}}\downarrow$		0.75		ns
		Slow slew rate (see Notes 8 and 9)			0.9		
$t_h$	Hold time	Fast slew rate (see Notes 7 and 9)	Data after CLK $\uparrow$ , $\overline{\text{CLK}}\downarrow$		0.75		ns
		Slow slew rate (see Notes 8 and 9)			0.9		

$^\dagger$  For this test condition,  $V_{DDQ}$  always is equal to  $V_{CC}$ .

- NOTES:
5.  $V_{REF}$  must be held at a valid input level and data inputs must be held low for a minimum time of  $t_{\text{act}} \text{ max}$ , after  $\overline{\text{RESET}}$  is taken high.
  6.  $V_{REF}$ , data, and clock inputs must be held at valid voltage levels (not floating) for a minimum time of  $t_{\text{inact}} \text{ max}$ , after  $\overline{\text{RESET}}$  is taken low.
  7. For data signal input slew rate  $\geq 1\text{ V/ns}$ .
  8. For data signal input slew rate  $\geq 0.5\text{ V/ns}$  and  $< 1\text{ V/ns}$ .
  9. CLK,  $\overline{\text{CLK}}$  signals input slew rates are  $\geq 1\text{ V/ns}$ .

switching characteristics over recommended operating free-air temperature range (unless otherwise noted) (see Figure 1)

PARAMETER	FROM (INPUT)	TO (OUTPUT)	$V_{CC} = 2.5\text{ V} \pm 0.2\text{ V}^\dagger$		$V_{CC} = 2.6\text{ V} \pm 0.1\text{ V}^\dagger$		UNIT
			MIN	MAX	MIN	MAX	
$f_{\text{max}}$			250		250		MHz
$t_{\text{pd}}^\ddagger$	CLK and $\overline{\text{CLK}}$	Q	1.1	2.6	1.1	2.6	ns
$t_{\text{PHL}}$	$\overline{\text{RESET}}$	Q	5		5		ns

$^\dagger$  For this test condition,  $V_{DDQ}$  always is equal to  $V_{CC}$ .

$^\ddagger$  Single bit switching



# SN74SSTVF16857

## 14-BIT REGISTERED BUFFER

### WITH SSTL 2 INPUTS AND OUTPUTS

SCES411B – AUGUST 2002 – REVISED APRIL 2003

#### PARAMETER MEASUREMENT INFORMATION

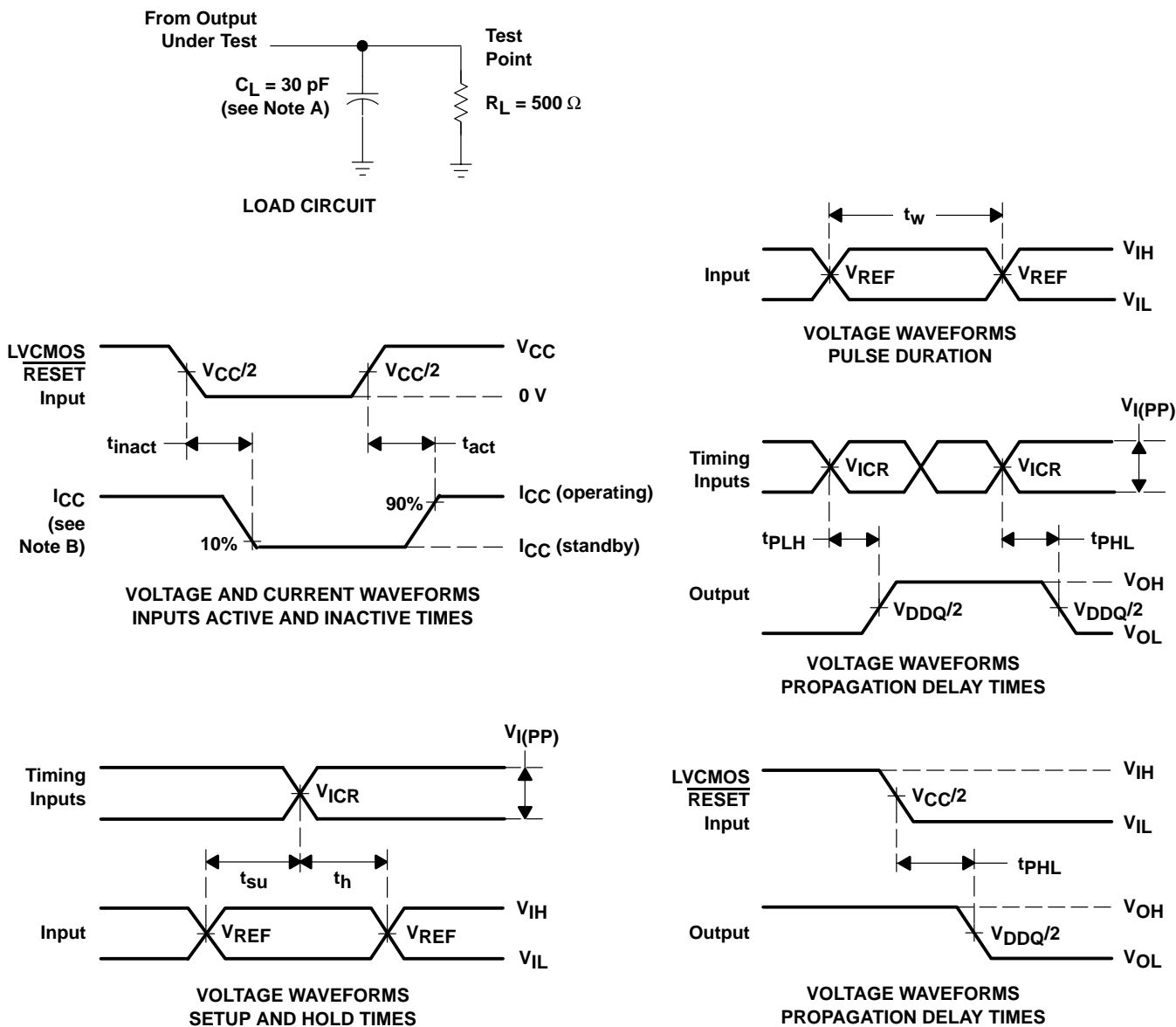

- NOTES:
- A.  $C_L$  includes probe and jig capacitance.
  - B.  $I_{CC}$  tested with clock and data inputs held at  $V_{CC}$  or GND, and  $I_O = 0 \text{ mA}$ .
  - C. All input pulses are supplied by generators having the following characteristics: PRR  $\leq 10 \text{ MHz}$ ,  $Z_O = 50 \Omega$ , input slew rate =  $1 \text{ V/ns} \pm 20\%$  (unless otherwise noted).
  - D. The outputs are measured one at a time with one transition per measurement.
  - E.  $V_{REF} = V_{DDQ}/2$
  - F.  $V_{IH} = V_{REF} + 310 \text{ mV}$  (ac voltage levels) for differential inputs.  $V_{IH} = V_{CC}$  for LVC MOS input.
  - G.  $V_{IL} = V_{REF} - 310 \text{ mV}$  (ac voltage levels) for differential inputs.  $V_{IL} = \text{GND}$  for LVC MOS input.
  - H.  $t_{PLH}$  and  $t_{PHL}$  are the same as  $t_{pd}$ .

Figure 1. Load Circuit and Voltage Waveforms

**PACKAGING INFORMATION**

Orderable Device	Status <sup>(1)</sup>	Package Type	Package Drawing	Pins	Package Qty	Eco Plan <sup>(2)</sup>	Lead/Ball Finish	MSL Peak Temp <sup>(3)</sup>
SN74SSTVF16857GR	ACTIVE	TSSOP	DGG	48	2000	Green (RoHS & no Sb/Br)	CU NIPDAU	Level-2-260C-1 YEAR
SN74SSTVF16857GRG4	ACTIVE	TSSOP	DGG	48	2000	Green (RoHS & no Sb/Br)	CU NIPDAU	Level-2-260C-1 YEAR
SN74SSTVF16857VR	ACTIVE	TVSOP	DGV	48	2000	Green (RoHS & no Sb/Br)	CU NIPDAU	Level-1-260C-UNLIM
SN74SSTVF16857VRG4	ACTIVE	TVSOP	DGV	48	2000	Green (RoHS & no Sb/Br)	CU NIPDAU	Level-1-260C-UNLIM

<sup>(1)</sup> The marketing status values are defined as follows:

**ACTIVE:** Product device recommended for new designs.

**LIFEBUY:** TI has announced that the device will be discontinued, and a lifetime-buy period is in effect.

**NRND:** Not recommended for new designs. Device is in production to support existing customers, but TI does not recommend using this part in a new design.

**PREVIEW:** Device has been announced but is not in production. Samples may or may not be available.

**OBSOLETE:** TI has discontinued the production of the device.

<sup>(2)</sup> Eco Plan - The planned eco-friendly classification: Pb-Free (RoHS), Pb-Free (RoHS Exempt), or Green (RoHS & no Sb/Br) - please check <http://www.ti.com/productcontent> for the latest availability information and additional product content details.

**TBD:** The Pb-Free/Green conversion plan has not been defined.

**Pb-Free (RoHS):** TI's terms "Lead-Free" or "Pb-Free" mean semiconductor products that are compatible with the current RoHS requirements for all 6 substances, including the requirement that lead not exceed 0.1% by weight in homogeneous materials. Where designed to be soldered at high temperatures, TI Pb-Free products are suitable for use in specified lead-free processes.

**Pb-Free (RoHS Exempt):** This component has a RoHS exemption for either 1) lead-based flip-chip solder bumps used between the die and package, or 2) lead-based die adhesive used between the die and leadframe. The component is otherwise considered Pb-Free (RoHS compatible) as defined above.

**Green (RoHS & no Sb/Br):** TI defines "Green" to mean Pb-Free (RoHS compatible), and free of Bromine (Br) and Antimony (Sb) based flame retardants (Br or Sb do not exceed 0.1% by weight in homogeneous material)

<sup>(3)</sup> MSL, Peak Temp. -- The Moisture Sensitivity Level rating according to the JEDEC industry standard classifications, and peak solder temperature.

**Important Information and Disclaimer:**The information provided on this page represents TI's knowledge and belief as of the date that it is provided. TI bases its knowledge and belief on information provided by third parties, and makes no representation or warranty as to the accuracy of such information. Efforts are underway to better integrate information from third parties. TI has taken and continues to take reasonable steps to provide representative and accurate information but may not have conducted destructive testing or chemical analysis on incoming materials and chemicals. TI and TI suppliers consider certain information to be proprietary, and thus CAS numbers and other limited information may not be available for release.

In no event shall TI's liability arising out of such information exceed the total purchase price of the TI part(s) at issue in this document sold by TI to Customer on an annual basis.

**TAPE AND REEL INFORMATION**

**QUADRANT ASSIGNMENTS FOR PIN 1 ORIENTATION IN TAPE**

\*All dimensions are nominal

Device	Package Type	Package Drawing	Pins	SPQ	Reel Diameter (mm)	Reel Width W1 (mm)	A0 (mm)	B0 (mm)	K0 (mm)	P1 (mm)	W (mm)	Pin1 Quadrant
SN74SSTVF16857GR	TSSOP	DGG	48	2000	330.0	24.4	8.6	15.8	1.8	12.0	24.0	Q1
SN74SSTVF16857VR	TVSOP	DGV	48	2000	330.0	16.4	7.1	10.2	1.6	12.0	16.0	Q1

**TAPE AND REEL BOX DIMENSIONS**

\*All dimensions are nominal

Device	Package Type	Package Drawing	Pins	SPQ	Length (mm)	Width (mm)	Height (mm)
SN74SSTVF16857GR	TSSOP	DGG	48	2000	346.0	346.0	41.0
SN74SSTVF16857VR	TVSOP	DGV	48	2000	346.0	346.0	33.0

DGG (R-PDSO-G\*\*)

PLASTIC SMALL-OUTLINE PACKAGE

48 PINS SHOWN



- NOTES: A. All linear dimensions are in millimeters.  
 B. This drawing is subject to change without notice.  
 C. Body dimensions do not include mold protrusion not to exceed 0,15.  
 D. Falls within JEDEC MO-153

DGV (R-PDSO-G\*\*)

PLASTIC SMALL-OUTLINE

24 PINS SHOWN



4073251/E 08/00

- NOTES: A. All linear dimensions are in millimeters.  
 B. This drawing is subject to change without notice.  
 C. Body dimensions do not include mold flash or protrusion, not to exceed 0,15 per side.  
 D. Falls within JEDEC: 24/48 Pins – MO-153  
 14/16/20/56 Pins – MO-194

## IMPORTANT NOTICE

Texas Instruments Incorporated and its subsidiaries (TI) reserve the right to make corrections, modifications, enhancements, improvements, and other changes to its products and services at any time and to discontinue any product or service without notice. Customers should obtain the latest relevant information before placing orders and should verify that such information is current and complete. All products are sold subject to TI's terms and conditions of sale supplied at the time of order acknowledgment.

TI warrants performance of its hardware products to the specifications applicable at the time of sale in accordance with TI's standard warranty. Testing and other quality control techniques are used to the extent TI deems necessary to support this warranty. Except where mandated by government requirements, testing of all parameters of each product is not necessarily performed.

TI assumes no liability for applications assistance or customer product design. Customers are responsible for their products and applications using TI components. To minimize the risks associated with customer products and applications, customers should provide adequate design and operating safeguards.

TI does not warrant or represent that any license, either express or implied, is granted under any TI patent right, copyright, mask work right, or other TI intellectual property right relating to any combination, machine, or process in which TI products or services are used. Information published by TI regarding third-party products or services does not constitute a license from TI to use such products or services or a warranty or endorsement thereof. Use of such information may require a license from a third party under the patents or other intellectual property of the third party, or a license from TI under the patents or other intellectual property of TI.

Reproduction of TI information in TI data books or data sheets is permissible only if reproduction is without alteration and is accompanied by all associated warranties, conditions, limitations, and notices. Reproduction of this information with alteration is an unfair and deceptive business practice. TI is not responsible or liable for such altered documentation. Information of third parties may be subject to additional restrictions.

Resale of TI products or services with statements different from or beyond the parameters stated by TI for that product or service voids all express and any implied warranties for the associated TI product or service and is an unfair and deceptive business practice. TI is not responsible or liable for any such statements.

TI products are not authorized for use in safety-critical applications (such as life support) where a failure of the TI product would reasonably be expected to cause severe personal injury or death, unless officers of the parties have executed an agreement specifically governing such use. Buyers represent that they have all necessary expertise in the safety and regulatory ramifications of their applications, and acknowledge and agree that they are solely responsible for all legal, regulatory and safety-related requirements concerning their products and any use of TI products in such safety-critical applications, notwithstanding any applications-related information or support that may be provided by TI. Further, Buyers must fully indemnify TI and its representatives against any damages arising out of the use of TI products in such safety-critical applications.

TI products are neither designed nor intended for use in military/aerospace applications or environments unless the TI products are specifically designated by TI as military-grade or "enhanced plastic." Only products designated by TI as military-grade meet military specifications. Buyers acknowledge and agree that any such use of TI products which TI has not designated as military-grade is solely at the Buyer's risk, and that they are solely responsible for compliance with all legal and regulatory requirements in connection with such use.

TI products are neither designed nor intended for use in automotive applications or environments unless the specific TI products are designated by TI as compliant with ISO/TS 16949 requirements. Buyers acknowledge and agree that, if they use any non-designated products in automotive applications, TI will not be responsible for any failure to meet such requirements.

Following are URLs where you can obtain information on other Texas Instruments products and application solutions:

### Products

Amplifiers	<a href="http://amplifier.ti.com">amplifier.ti.com</a>
Data Converters	<a href="http://dataconverter.ti.com">dataconverter.ti.com</a>
DLP® Products	<a href="http://www.dlp.com">www.dlp.com</a>
DSP	<a href="http://dsp.ti.com">dsp.ti.com</a>
Clocks and Timers	<a href="http://www.ti.com/clocks">www.ti.com/clocks</a>
Interface	<a href="http://interface.ti.com">interface.ti.com</a>
Logic	<a href="http://logic.ti.com">logic.ti.com</a>
Power Mgmt	<a href="http://power.ti.com">power.ti.com</a>
Microcontrollers	<a href="http://microcontroller.ti.com">microcontroller.ti.com</a>
RFID	<a href="http://www.ti-rfid.com">www.ti-rfid.com</a>
RF/IF and ZigBee® Solutions	<a href="http://www.ti.com/lprf">www.ti.com/lprf</a>

### Applications

Audio	<a href="http://www.ti.com/audio">www.ti.com/audio</a>
Automotive	<a href="http://www.ti.com/automotive">www.ti.com/automotive</a>
Broadband	<a href="http://www.ti.com/broadband">www.ti.com/broadband</a>
Digital Control	<a href="http://www.ti.com/digitalcontrol">www.ti.com/digitalcontrol</a>
Medical	<a href="http://www.ti.com/medical">www.ti.com/medical</a>
Military	<a href="http://www.ti.com/military">www.ti.com/military</a>
Optical Networking	<a href="http://www.ti.com/opticalnetwork">www.ti.com/opticalnetwork</a>
Security	<a href="http://www.ti.com/security">www.ti.com/security</a>
Telephony	<a href="http://www.ti.com/telephony">www.ti.com/telephony</a>
Video & Imaging	<a href="http://www.ti.com/video">www.ti.com/video</a>
Wireless	<a href="http://www.ti.com/wireless">www.ti.com/wireless</a>

Mailing Address: Texas Instruments, Post Office Box 655303, Dallas, Texas 75265  
Copyright © 2009, Texas Instruments Incorporated

## Looking for pricing, stock, or lifecycle information?

Click below to explore more details on WIN SOURCE:

 [View SN74SSTV16857DGVRG on WIN SOURCE](#)

 [Texas Instruments](#) Information

## Optimize Your Supply Chain with WIN SOURCE Solutions

-  Global Sourcing Solution
-  Obsolete Management
-  Cost Control Management
-  Shortage Management
-  Alternative Solution
-  Excess Inventory Management