



**THE DATASHEET OF  
S29AS016J70BHI043**



# SN74LV4053A-EP

## TRIPLE 2-CHANNEL ANALOG MULTIPLEXER/DEMULPLEXER

SCLS503C – MAY 2003 – REVISED MAY 2004

- **Controlled Baseline**
  - One Assembly/Test Site, One Fabrication Site
- **Extended Temperature Performance of –40°C to 105°C**
- **Enhanced Diminishing Manufacturing Sources (DMS) Support**
- **Enhanced Product-Change Notification**
- **Qualification Pedigree†**
- **2-V to 5.5-V  $V_{CC}$  Operation**
- **Supports Mixed-Mode Voltage Operation on All Ports**
- **High On-Off Output-Voltage Ratio**
- **Low Crosstalk Between Switches**
- **Individual Switch Controls**
- **Extremely Low Input Current**
- **Latch-Up Performance Exceeds 250 mA Per JESD 17**
- **ESD Protection Exceeds JESD 22**
  - 2000-V Human-Body Model (A114-A)
  - 200-V Machine Model (A115-A)
  - 1000-V Charged-Device Model (C101)

† Component qualification in accordance with JEDEC and industry standards to ensure reliable operation over an extended temperature range. This includes, but is not limited to, Highly Accelerated Stress Test (HAST) or biased 85/85, temperature cycle, autoclave or unbiased HAST, electromigration, bond intermetallic life, and mold compound life. Such qualification testing should not be viewed as justifying use of this component beyond specified performance and environmental limits.

D OR PW PACKAGE  
(TOP VIEW)

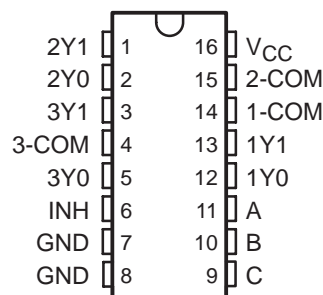

### description/ordering information

This triple 2-channel CMOS analog multiplexer/demultiplexer is designed for 2-V to 5.5-V  $V_{CC}$  operation.

The SN74LV4053A handles both analog and digital signals. Each channel permits signals with amplitudes up to 5.5 V (peak) to be transmitted in either direction.

Applications include signal gating, chopping, modulation or demodulation (modem), and signal multiplexing for analog-to-digital and digital-to-analog conversion systems.

### ORDERING INFORMATION

$T_A$	PACKAGE‡		ORDERABLE PART NUMBER	TOP-SIDE MARKING
–40°C to 105°C	SOIC – D	Tape and reel	SN74LV4053ATDREP	LV4053ATEP
	TSSOP – PW	Tape and reel	SN74LV4053ATPWREP	L4053EP

‡ Package drawings, standard packing quantities, thermal data, symbolization, and PCB design guidelines are available at [www.ti.com/sc/package](http://www.ti.com/sc/package).



Please be aware that an important notice concerning availability, standard warranty, and use in critical applications of Texas Instruments semiconductor products and disclaimers thereto appears at the end of this data sheet.

PRODUCTION DATA information is current as of publication date. Products conform to specifications per the terms of Texas Instruments standard warranty. Production processing does not necessarily include testing of all parameters.



POST OFFICE BOX 655303 • DALLAS, TEXAS 75265

Copyright © 2004, Texas Instruments Incorporated

# SN74LV4053A-EP

## TRIPLE 2-CHANNEL ANALOG MULTIPLEXER/DEMULTIPLEXER

SCLS503C – MAY 2003 – REVISED MAY 2004

FUNCTION TABLE

INPUTS				ON CHANNELS
INH	C	B	A	
L	L	L	L	1Y0, 2Y0, 3Y0
L	L	L	H	1Y1, 2Y0, 3Y0
L	L	H	L	1Y0, 2Y1, 3Y0
L	L	H	H	1Y1, 2Y1, 3Y0
L	H	L	L	1Y0, 2Y0, 3Y1
L	H	L	H	1Y1, 2Y0, 3Y1
L	H	H	L	1Y0, 2Y1, 3Y1
L	H	H	H	1Y1, 2Y1, 3Y1
H	X	X	X	None

logic diagram (positive logic)

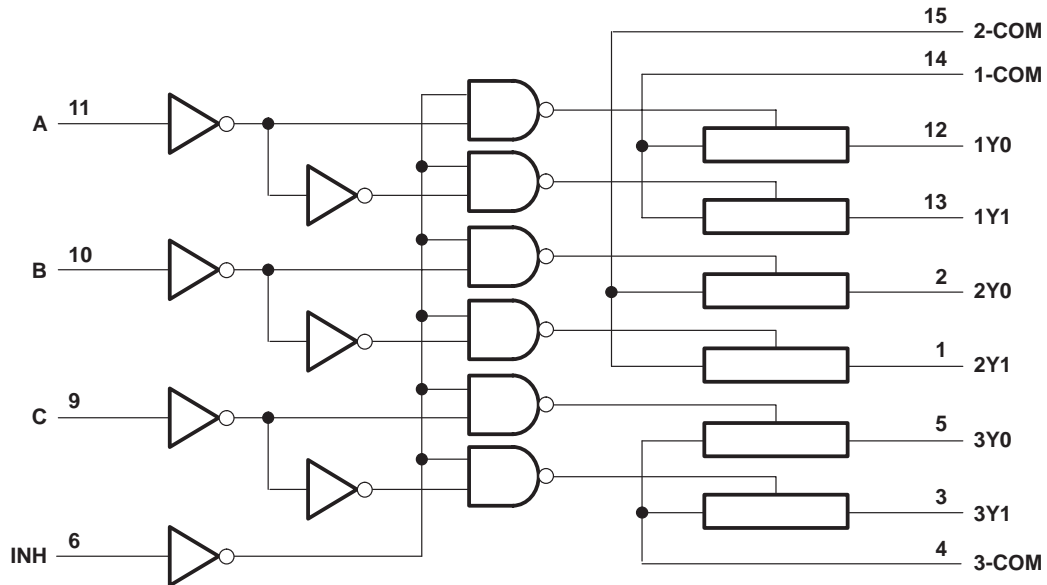

# SN74LV4053A-EP

## TRIPLE 2-CHANNEL ANALOG MULTIPLEXER/DEMULTIPLEXER

SCLS503C – MAY 2003 – REVISED MAY 2004

### absolute maximum ratings over operating free-air temperature range (unless otherwise noted)†

Supply voltage range, $V_{CC}$ .....	–0.5 V to 7.0 V
Input voltage range, $V_I$ (see Note 1) .....	–0.5 V to 7.0 V
Switch I/O voltage range, $V_{IO}$ (see Notes 1 and 2) .....	–0.5 V to $V_{CC} + 0.5$ V
Input clamp current, $I_{IK}$ ( $V_I < 0$ ) .....	–20 mA
I/O diode current, $I_{IOK}$ ( $V_{IO} < 0$ ) .....	–50 mA
Switch through current, $I_T$ ( $V_{IO} = 0$ to $V_{CC}$ ) .....	±25 mA
Continuous current through $V_{CC}$ or GND .....	±50 mA
Package thermal impedance, $\theta_{JA}$ (see Note 3): D package .....	73°C/W
PW package .....	108°C/W
Storage temperature range, $T_{stg}$ .....	–65°C to 150°C

† Stresses beyond those listed under “absolute maximum ratings” may cause permanent damage to the device. These are stress ratings only, and functional operation of the device at these or any other conditions beyond those indicated under “recommended operating conditions” is not implied. Exposure to absolute-maximum-rated conditions for extended periods may affect device reliability.

- NOTES: 1. The input and output negative-voltage ratings may be exceeded if the input and output clamp-current ratings are observed.  
 2. This value is limited to 5.5 V maximum.  
 3. The package thermal impedance is calculated in accordance with JESD 51-7.

### recommended operating conditions (see Note 4)

		MIN	MAX	UNIT
$V_{CC}$	Supply voltage	2‡	5.5	V
$V_{IH}$	High-level input voltage, control inputs	$V_{CC} = 2$ V	1.5	V
		$V_{CC} = 2.3$ V to 2.7 V	$V_{CC} \times 0.7$	
		$V_{CC} = 3$ V to 3.6 V	$V_{CC} \times 0.7$	
		$V_{CC} = 4.5$ V to 5.5 V	$V_{CC} \times 0.7$	
$V_{IL}$	Low-level input voltage, control inputs	$V_{CC} = 2$ V	0.5	V
		$V_{CC} = 2.3$ V to 2.7 V	$V_{CC} \times 0.3$	
		$V_{CC} = 3$ V to 3.6 V	$V_{CC} \times 0.3$	
		$V_{CC} = 4.5$ V to 5.5 V	$V_{CC} \times 0.3$	
$V_I$	Control input voltage	0	5.5	V
$V_{IO}$	Input/output voltage	0	$V_{CC}$	V
$\Delta t/\Delta v$	Input transition rise or fall rate	$V_{CC} = 2.3$ V to 2.7 V	200	ns/V
		$V_{CC} = 3$ V to 3.6 V	100	
		$V_{CC} = 4.5$ V to 5.5 V	20	
$T_A$	Operating free-air temperature	–40	105	°C

‡ With supply voltages at or near 2 V, the analog switch on-state resistance becomes very nonlinear. It is recommended that only digital signals be transmitted at these low supply voltages.

NOTE 4: All unused inputs of the device must be held at  $V_{CC}$  or GND to ensure proper device operation. Refer to the TI application report, *Implications of Slow or Floating CMOS Inputs*, literature number SCBA004.



# SN74LV4053A-EP

## TRIPLE 2-CHANNEL ANALOG MULTIPLEXER/DEMULTIPLEXER

SCLS503C – MAY 2003 – REVISED MAY 2004

electrical characteristics over recommended operating free-air temperature range (unless otherwise noted)

PARAMETER	TEST CONDITIONS	V <sub>CC</sub>	T <sub>A</sub> = 25°C			MIN	MAX	UNIT
			MIN	TYP	MAX			
r <sub>on</sub> On-state switch resistance	I <sub>T</sub> = 2 mA, V <sub>I</sub> = V <sub>CC</sub> or GND, V <sub>INH</sub> = V <sub>IL</sub> , (see Figure 1)	2.3 V		41	180		225	Ω
		3 V		30	150		190	
		4.5 V		23	75		100	
r <sub>on(p)</sub> Peak on-state resistance	I <sub>T</sub> = 2 mA, V <sub>I</sub> = V <sub>CC</sub> to GND, V <sub>INH</sub> = V <sub>IL</sub>	2.3 V		139	500		600	Ω
		3 V		63	180		225	
		4.5 V		35	100		125	
Δr <sub>on</sub> Difference in on-state resistance between switches	I <sub>T</sub> = 2 mA, V <sub>I</sub> = V <sub>CC</sub> to GND, V <sub>INH</sub> = V <sub>IL</sub>	2.3 V		2	30		40	Ω
		3 V		1.6	20		30	
		4.5 V		1.3	15		20	
I <sub>I</sub> Control input current	V <sub>I</sub> = 5.5 V or GND	0 to 5.5 V			±0.1		±1	μA
I <sub>S(off)</sub> Off-state switch leakage current	V <sub>I</sub> = V <sub>CC</sub> and V <sub>O</sub> = GND, or V <sub>I</sub> = GND and V <sub>O</sub> = V <sub>CC</sub> , V <sub>INH</sub> = V <sub>IH</sub> , (see Figure 2)	5.5 V			±0.1		±1	μA
I <sub>S(on)</sub> On-state switch leakage current	V <sub>I</sub> = V <sub>CC</sub> or GND, V <sub>INH</sub> = V <sub>IH</sub> (see Figure 3)	5.5 V			±0.1		±1	μA
I <sub>CC</sub> Supply current	V <sub>I</sub> = V <sub>CC</sub> or GND	5.5 V					20	μA
C <sub>IC</sub> Control input capacitance				2				pF
C <sub>IS</sub> Common terminal capacitance				8.2				pF
C <sub>OS</sub> Switch terminal capacitance				5.6				pF
C <sub>F</sub> Feedthrough capacitance				0.5				pF

switching characteristics over recommended operating free-air temperature range, V<sub>CC</sub> = 2.5 V ± 0.2 V (unless otherwise noted)

PARAMETER	FROM (INPUT)	TO (OUTPUT)	TEST CONDITIONS	T <sub>A</sub> = 25°C			MIN	MAX	UNIT
				MIN	TYP	MAX			
t <sub>PLH</sub> t <sub>PHL</sub> Propagation delay time	COM or Y <sub>n</sub>	Y <sub>n</sub> or COM	C <sub>L</sub> = 15 pF, (see Figure 4)		2.5	10		16	ns
t <sub>PZH</sub> t <sub>PZL</sub> Enable delay time	INH	COM or Y <sub>n</sub>	C <sub>L</sub> = 15 pF, (see Figure 5)		7.6	18		23	ns
t <sub>PHZ</sub> t <sub>PLZ</sub> Disable delay time	INH	COM or Y <sub>n</sub>	C <sub>L</sub> = 15 pF, (see Figure 5)		7.7	18		23	ns
t <sub>PLH</sub> t <sub>PHL</sub> Propagation delay time	COM or Y <sub>n</sub>	Y <sub>n</sub> or COM	C <sub>L</sub> = 50 pF, (see Figure 4)		4.4	12		18	ns
t <sub>PZH</sub> t <sub>PZL</sub> Enable delay time	INH	COM or Y <sub>n</sub>	C <sub>L</sub> = 50 pF, (see Figure 5)		8.8	28		35	ns
t <sub>PHZ</sub> t <sub>PLZ</sub> Disable delay time	INH	COM or Y <sub>n</sub>	C <sub>L</sub> = 50 pF, (see Figure 5)		11.7	28		35	ns



# SN74LV4053A-EP

## TRIPLE 2-CHANNEL ANALOG MULTIPLEXER/DEMULTIPLEXER

SCLS503C – MAY 2003 – REVISED MAY 2004

**switching characteristics over recommended operating free-air temperature range,  
V<sub>CC</sub> = 3.3 V ± 0.3 V (unless otherwise noted)**

PARAMETER	FROM (INPUT)	TO (OUTPUT)	TEST CONDITIONS	T <sub>A</sub> = 25°C			MIN	MAX	UNIT
				MIN	TYP	MAX			
t <sub>PLH</sub> t <sub>PHL</sub>	Propagation delay time	COM or Y <sub>n</sub>	Y <sub>n</sub> or COM	C <sub>L</sub> = 15 pF, (see Figure 4)	1.6	6		10	ns
t <sub>PZH</sub> t <sub>PZL</sub>	Enable delay time	INH	COM or Y <sub>n</sub>	C <sub>L</sub> = 15 pF, (see Figure 5)	5.3	12		15	ns
t <sub>PHZ</sub> t <sub>PLZ</sub>	Disable delay time	INH	COM or Y <sub>n</sub>	C <sub>L</sub> = 15 pF, (see Figure 5)	6.1	12		15	ns
t <sub>PLH</sub> t <sub>PHL</sub>	Propagation delay time	COM or Y <sub>n</sub>	Y <sub>n</sub> or COM	C <sub>L</sub> = 50 pF, (see Figure 4)	2.9	9		12	ns
t <sub>PZH</sub> t <sub>PZL</sub>	Enable delay time	INH	COM or Y <sub>n</sub>	C <sub>L</sub> = 50 pF, (see Figure 5)	6.1	20		25	ns
t <sub>PHZ</sub> t <sub>PLZ</sub>	Disable delay time	INH	COM or Y <sub>n</sub>	C <sub>L</sub> = 50 pF, (see Figure 5)	8.9	20		25	ns

**switching characteristics over recommended operating free-air temperature range,  
V<sub>CC</sub> = 5 V ± 0.5 V (unless otherwise noted)**

PARAMETER	FROM (INPUT)	TO (OUTPUT)	TEST CONDITIONS	T <sub>A</sub> = 25°C			MIN	MAX	UNIT
				MIN	TYP	MAX			
t <sub>PLH</sub> t <sub>PHL</sub>	Propagation delay time	COM or Y <sub>n</sub>	Y <sub>n</sub> or COM	C <sub>L</sub> = 15 pF, (see Figure 4)	0.9	4		7	ns
t <sub>PZH</sub> t <sub>PZL</sub>	Enable delay time	INH	COM or Y <sub>n</sub>	C <sub>L</sub> = 15 pF, (see Figure 5)	3.8	8		10	ns
t <sub>PHZ</sub> t <sub>PLZ</sub>	Disable delay time	INH	COM or Y <sub>n</sub>	C <sub>L</sub> = 15 pF, (see Figure 5)	4.6	8		10	ns
t <sub>PLH</sub> t <sub>PHL</sub>	Propagation delay time	COM or Y <sub>n</sub>	Y <sub>n</sub> or COM	C <sub>L</sub> = 50 pF, (see Figure 4)	1.8	6		8	ns
t <sub>PZH</sub> t <sub>PZL</sub>	Enable delay time	INH	COM or Y <sub>n</sub>	C <sub>L</sub> = 50 pF, (see Figure 5)	4.3	14		18	ns
t <sub>PHZ</sub> t <sub>PLZ</sub>	Disable delay time	INH	COM or Y <sub>n</sub>	C <sub>L</sub> = 50 pF, (see Figure 5)	6.3	14		18	ns

# SN74LV4053A-EP

## TRIPLE 2-CHANNEL ANALOG MULTIPLEXER/DEMULTIPLEXER

SCLS503C – MAY 2003 – REVISED MAY 2004

### analog switch characteristics

PARAMETER	FROM (INPUT)	TO (OUTPUT)	TEST CONDITIONS	V <sub>CC</sub>	T <sub>A</sub> = 25°C			UNIT
					MIN	TYP	MAX	
Frequency response (switch on)	COM or Y <sub>n</sub>	Y <sub>n</sub> or COM	C <sub>L</sub> = 50 pF, R <sub>L</sub> = 600 Ω, f <sub>in</sub> = 1 MHz (sine wave) (see Note 5 and Figure 6)	2.3 V	30		MHz	
				3 V	35			
				4.5 V	50			
Crosstalk (between any switches)	COM or Y <sub>n</sub>	Y <sub>n</sub> or COM	C <sub>L</sub> = 50 pF, R <sub>L</sub> = 600 Ω, f <sub>in</sub> = 1 MHz (sine wave) (see Note 6 and Figure 7)	2.3 V	-45		dB	
				3 V	-45			
				4.5 V	-45			
Crosstalk (control input to signal output)	INH	COM or Y <sub>n</sub>	C <sub>L</sub> = 50 pF, R <sub>L</sub> = 600 Ω, f <sub>in</sub> = 1 MHz (square wave) (see Figure 8)	2.3 V	20		mV	
				3 V	35			
				4.5 V	65			
Feedthrough attenuation (switch off)	COM or Y <sub>n</sub>	Y <sub>n</sub> or COM	C <sub>L</sub> = 50 pF, R <sub>L</sub> = 600 Ω, f <sub>in</sub> = 1 MHz (see Note 6 and Figure 9)	2.3 V	-45		dB	
				3 V	-45			
				4.5 V	-45			
Sine-wave distortion	COM or Y <sub>n</sub>	Y <sub>n</sub> or COM	C <sub>L</sub> = 50 pF, R <sub>L</sub> = 10 kΩ, f <sub>in</sub> = 1 kHz (sine wave) (see Figure 10)	V <sub>I</sub> = 2 V <sub>p-p</sub>	2.3 V	0.1		%
				V <sub>I</sub> = 2.5 V <sub>p-p</sub>	3 V	0.1		
				V <sub>I</sub> = 4 V <sub>p-p</sub>	4.5 V	0.1		

NOTES: 5. Adjust f<sub>in</sub> voltage to obtain 0-dBm output. Increase f<sub>in</sub> frequency until dB meter reads -3 dB.  
6. Adjust f<sub>in</sub> voltage to obtain 0-dBm input.

### operating characteristics, V<sub>CC</sub> = 3.3 V, T<sub>A</sub> = 25°C

PARAMETER	TEST CONDITIONS	TYP	UNIT
C <sub>pd</sub> Power dissipation capacitance	C <sub>L</sub> = 50 pF, f = 10 MHz	5.3	pF

### PARAMETER MEASUREMENT INFORMATION

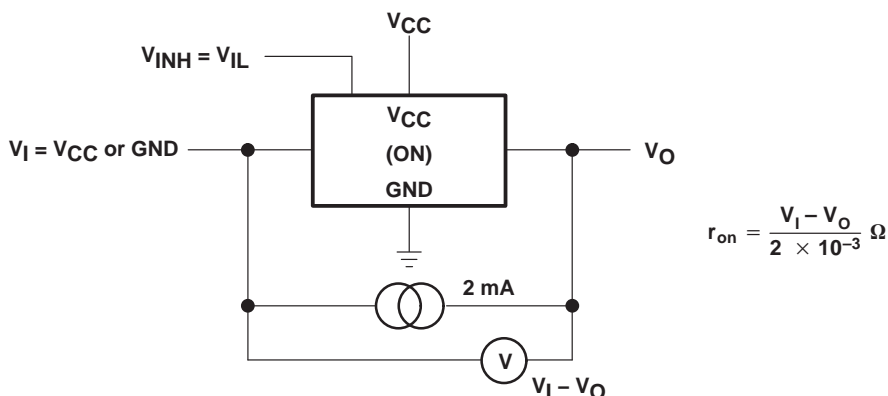
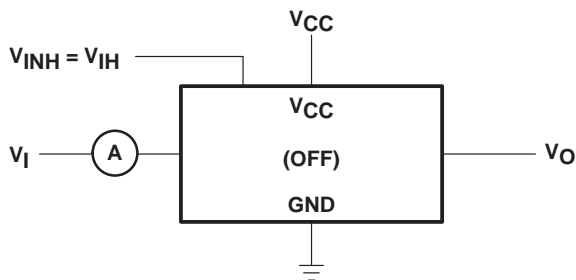

Figure 1. On-State Resistance Test Circuit

**PARAMETER MEASUREMENT INFORMATION**



Condition 1:  $V_I = 0, V_O = V_{CC}$   
 Condition 2:  $V_I = V_{CC}, V_O = 0$

**Figure 2. Off-State Switch Leakage-Current Test Circuit**

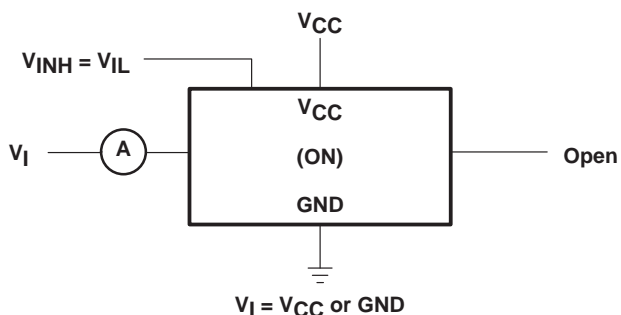

$V_I = V_{CC}$  or  $GND$

**Figure 3. On-State Switch Leakage-Current Test Circuit**

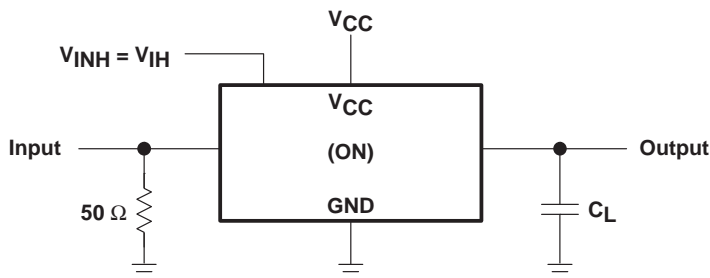

**Figure 4. Propagation Delay Time, Signal Input to Signal Output**

# SN74LV4053A-EP TRIPLE 2-CHANNEL ANALOG MULTIPLEXER/DEMULTIPLEXER

SCLS503C – MAY 2003 – REVISED MAY 2004

## PARAMETER MEASUREMENT INFORMATION

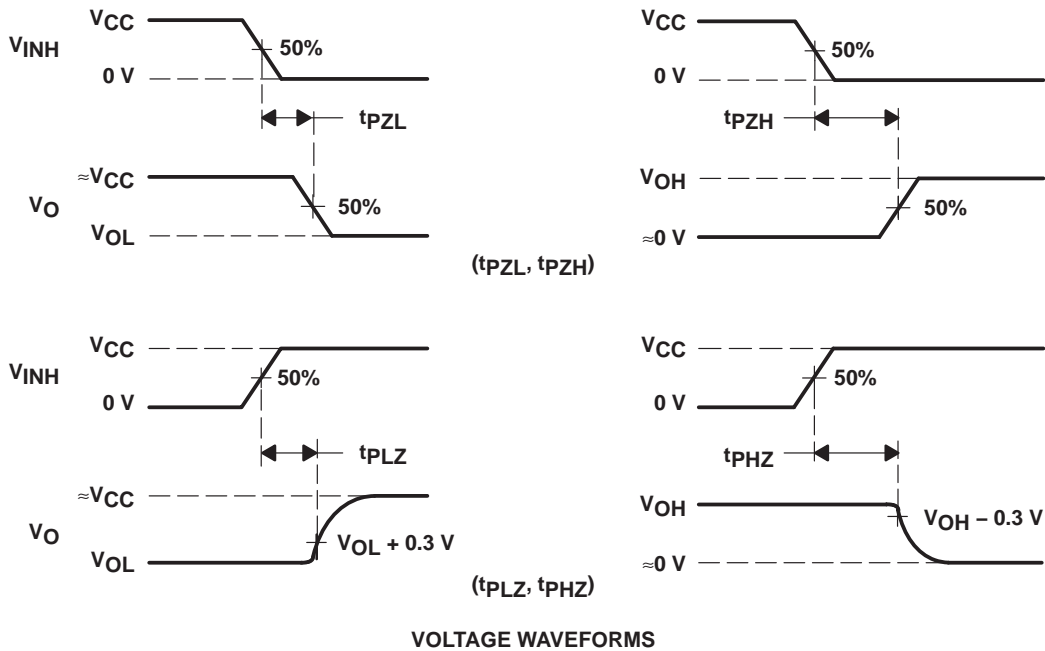
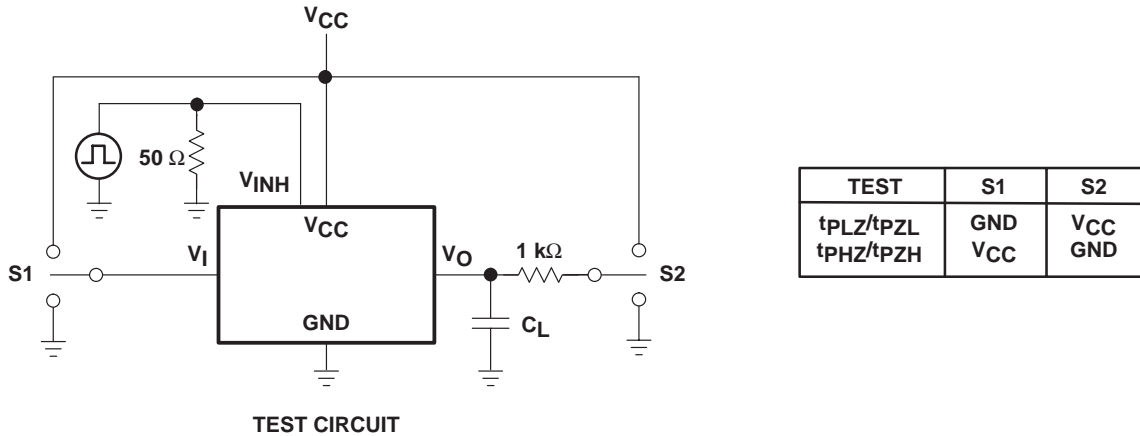
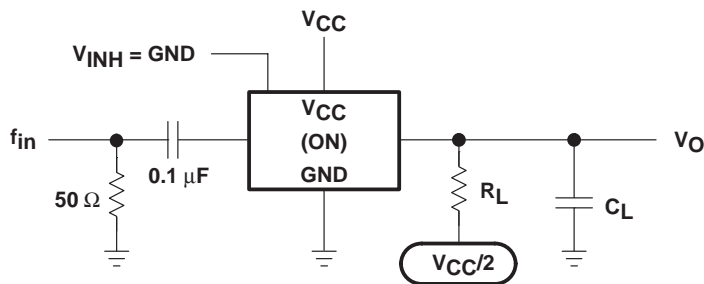

Figure 5. Switching Time ( $t_{PZL}$ ,  $t_{PLZ}$ ,  $t_{PHZ}$ ,  $t_{PHZ}$ ), Control to Signal Output



NOTE A:  $f_{in}$  is a sine wave.

Figure 6. Frequency Response (Switch On)

**PARAMETER MEASUREMENT INFORMATION**

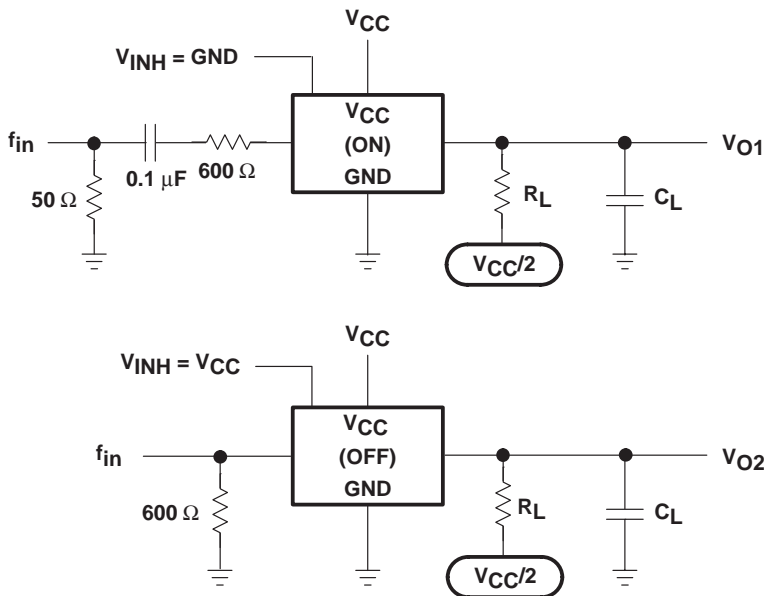

**Figure 7. Crosstalk Between Any Two Switches**

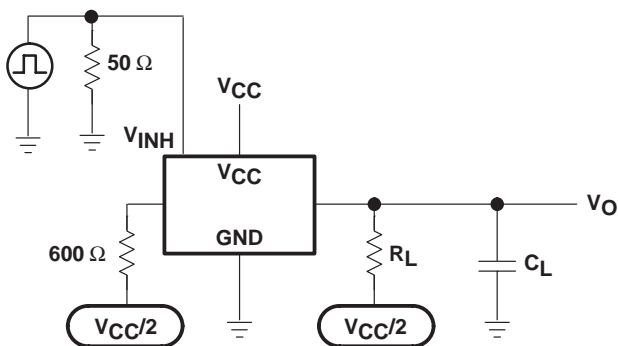

**Figure 8. Crosstalk Between Control Input and Switch Output**

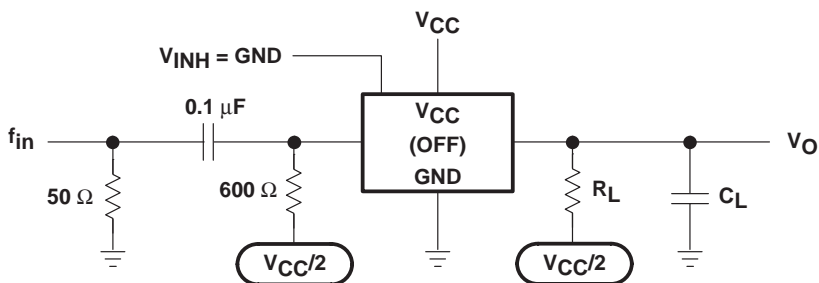

**Figure 9. Feedthrough Attenuation (Switch Off)**

# SN74LV4053A-EP

## TRIPLE 2-CHANNEL ANALOG MULTIPLEXER/DEMULTIPLEXER

SCLS503C – MAY 2003 – REVISED MAY 2004

### PARAMETER MEASUREMENT INFORMATION

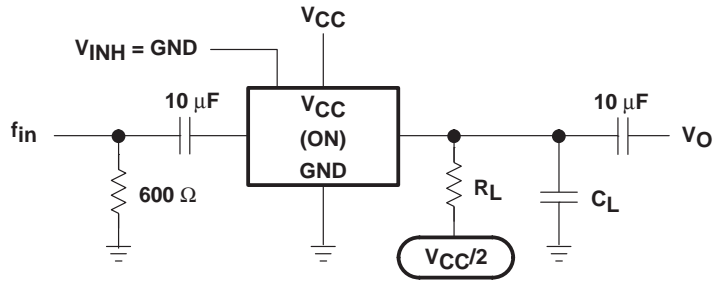

Figure 10. Sine-Wave Distortion

**PACKAGING INFORMATION**

Orderable Device	Status (1)	Package Type	Package Drawing	Pins	Package Qty	Eco Plan (2)	Lead finish/ Ball material (6)	MSL Peak Temp (3)	Op Temp (°C)	Device Marking (4/5)	Samples
SN74LV4053ATPWREP	ACTIVE	TSSOP	PW	16	2000	RoHS & Green	NIPDAU	Level-1-260C-UNLIM	-40 to 105	L4053EP	<a href="#">Samples</a>
V62/03666-01XE	ACTIVE	TSSOP	PW	16	2000	RoHS & Green	NIPDAU	Level-1-260C-UNLIM	-40 to 105	L4053EP	<a href="#">Samples</a>

(1) The marketing status values are defined as follows:

**ACTIVE:** Product device recommended for new designs.

**LIFEBUY:** TI has announced that the device will be discontinued, and a lifetime-buy period is in effect.

**NRND:** Not recommended for new designs. Device is in production to support existing customers, but TI does not recommend using this part in a new design.

**PREVIEW:** Device has been announced but is not in production. Samples may or may not be available.

**OBSOLETE:** TI has discontinued the production of the device.

(2) **RoHS:** TI defines "RoHS" to mean semiconductor products that are compliant with the current EU RoHS requirements for all 10 RoHS substances, including the requirement that RoHS substance do not exceed 0.1% by weight in homogeneous materials. Where designed to be soldered at high temperatures, "RoHS" products are suitable for use in specified lead-free processes. TI may reference these types of products as "Pb-Free".

**RoHS Exempt:** TI defines "RoHS Exempt" to mean products that contain lead but are compliant with EU RoHS pursuant to a specific EU RoHS exemption.

**Green:** TI defines "Green" to mean the content of Chlorine (Cl) and Bromine (Br) based flame retardants meet JS709B low halogen requirements of <=1000ppm threshold. Antimony trioxide based flame retardants must also meet the <=1000ppm threshold requirement.

(3) MSL, Peak Temp. - The Moisture Sensitivity Level rating according to the JEDEC industry standard classifications, and peak solder temperature.

(4) There may be additional marking, which relates to the logo, the lot trace code information, or the environmental category on the device.

(5) Multiple Device Markings will be inside parentheses. Only one Device Marking contained in parentheses and separated by a "~" will appear on a device. If a line is indented then it is a continuation of the previous line and the two combined represent the entire Device Marking for that device.

(6) Lead finish/Ball material - Orderable Devices may have multiple material finish options. Finish options are separated by a vertical ruled line. Lead finish/Ball material values may wrap to two lines if the finish value exceeds the maximum column width.

**Important Information and Disclaimer:**The information provided on this page represents TI's knowledge and belief as of the date that it is provided. TI bases its knowledge and belief on information provided by third parties, and makes no representation or warranty as to the accuracy of such information. Efforts are underway to better integrate information from third parties. TI has taken and continues to take reasonable steps to provide representative and accurate information but may not have conducted destructive testing or chemical analysis on incoming materials and chemicals. TI and TI suppliers consider certain information to be proprietary, and thus CAS numbers and other limited information may not be available for release.

In no event shall TI's liability arising out of such information exceed the total purchase price of the TI part(s) at issue in this document sold by TI to Customer on an annual basis.

**OTHER QUALIFIED VERSIONS OF SN74LV4053A-EP :**

- Catalog: [SN74LV4053A](#)
- Automotive: [SN74LV4053A-Q1](#)

## NOTE: Qualified Version Definitions:

- Catalog - TI's standard catalog product
- Automotive - Q100 devices qualified for high-reliability automotive applications targeting zero defects

**TAPE AND REEL INFORMATION**

**QUADRANT ASSIGNMENTS FOR PIN 1 ORIENTATION IN TAPE**

\*All dimensions are nominal

Device	Package Type	Package Drawing	Pins	SPQ	Reel Diameter (mm)	Reel Width W1 (mm)	A0 (mm)	B0 (mm)	K0 (mm)	P1 (mm)	W (mm)	Pin1 Quadrant
SN74LV4053ATPWREP	TSSOP	PW	16	2000	330.0	12.4	6.9	5.6	1.6	8.0	12.0	Q1

**TAPE AND REEL BOX DIMENSIONS**

\*All dimensions are nominal

Device	Package Type	Package Drawing	Pins	SPQ	Length (mm)	Width (mm)	Height (mm)
SN74LV4053ATPWREP	TSSOP	PW	16	2000	356.0	356.0	35.0



NOTES:

1. All linear dimensions are in millimeters. Any dimensions in parenthesis are for reference only. Dimensioning and tolerancing per ASME Y14.5M.
2. This drawing is subject to change without notice.
3. This dimension does not include mold flash, protrusions, or gate burrs. Mold flash, protrusions, or gate burrs shall not exceed 0.15 mm per side.
4. This dimension does not include interlead flash. Interlead flash shall not exceed 0.25 mm per side.
5. Reference JEDEC registration MO-153.

# EXAMPLE BOARD LAYOUT

PW0016A

TSSOP - 1.2 mm max height

SMALL OUTLINE PACKAGE



LAND PATTERN EXAMPLE  
EXPOSED METAL SHOWN  
SCALE: 10X



4220204/A 02/2017

NOTES: (continued)

- 6. Publication IPC-7351 may have alternate designs.
- 7. Solder mask tolerances between and around signal pads can vary based on board fabrication site.

# EXAMPLE STENCIL DESIGN

PW0016A

TSSOP - 1.2 mm max height

SMALL OUTLINE PACKAGE



SOLDER PASTE EXAMPLE  
BASED ON 0.125 mm THICK STENCIL  
SCALE: 10X

4220204/A 02/2017

NOTES: (continued)

8. Laser cutting apertures with trapezoidal walls and rounded corners may offer better paste release. IPC-7525 may have alternate design recommendations.
9. Board assembly site may have different recommendations for stencil design.

## IMPORTANT NOTICE AND DISCLAIMER

TI PROVIDES TECHNICAL AND RELIABILITY DATA (INCLUDING DATA SHEETS), DESIGN RESOURCES (INCLUDING REFERENCE DESIGNS), APPLICATION OR OTHER DESIGN ADVICE, WEB TOOLS, SAFETY INFORMATION, AND OTHER RESOURCES "AS IS" AND WITH ALL FAULTS, AND DISCLAIMS ALL WARRANTIES, EXPRESS AND IMPLIED, INCLUDING WITHOUT LIMITATION ANY IMPLIED WARRANTIES OF MERCHANTABILITY, FITNESS FOR A PARTICULAR PURPOSE OR NON-INFRINGEMENT OF THIRD PARTY INTELLECTUAL PROPERTY RIGHTS.

These resources are intended for skilled developers designing with TI products. You are solely responsible for (1) selecting the appropriate TI products for your application, (2) designing, validating and testing your application, and (3) ensuring your application meets applicable standards, and any other safety, security, regulatory or other requirements.

These resources are subject to change without notice. TI grants you permission to use these resources only for development of an application that uses the TI products described in the resource. Other reproduction and display of these resources is prohibited. No license is granted to any other TI intellectual property right or to any third party intellectual property right. TI disclaims responsibility for, and you will fully indemnify TI and its representatives against, any claims, damages, costs, losses, and liabilities arising out of your use of these resources.

TI's products are provided subject to [TI's Terms of Sale](#) or other applicable terms available either on [ti.com](http://ti.com) or provided in conjunction with such TI products. TI's provision of these resources does not expand or otherwise alter TI's applicable warranties or warranty disclaimers for TI products.

TI objects to and rejects any additional or different terms you may have proposed.

Mailing Address: Texas Instruments, Post Office Box 655303, Dallas, Texas 75265  
Copyright © 2022, Texas Instruments Incorporated

## Looking for pricing, stock, or lifecycle information?

Click below to explore more details on WIN SOURCE:

- ⊖ [View S29AS016J70BHI043 on WIN SOURCE](#)
- ⊖ [Cypress Semiconductor Corp Information](#)

## Optimize Your Supply Chain with WIN SOURCE Solutions

- ✓ Global Sourcing Solution
- ✓ Obsolete Management
- ✓ Cost Control Management
- ✓ Shortage Management
- ✓ Alternative Solution
- ✓ Excess Inventory Management