



**THE DATASHEET OF
S25FL129P0XBHV303**



CSD97395Q4M Synchronous Buck NexFET™ Power Stage

1 Features

- Over 92% System Efficiency at 15 A
- Max Rated Continuous Current 25 A, Peak 60 A
- High Frequency Operation (up to 2 MHz)
- High Density – SON 3.5 mm x 4.5 mm Footprint
- Ultra-Low Inductance Package
- System-Optimized PCB Footprint
- Ultra-Low Quiescent (ULQ) Current Mode
- 3.3 V and 5 V PWM Signal Compatible
- Diode Emulation Mode With FCCM
- Input Voltages up to 24 V
- Tri-State PWM Input
- Integrated Bootstrap Diode
- Shoot Through Protection
- RoHS Compliant – Lead Free Terminal Plating
- Halogen Free

2 Applications

- Ultrabook/Notebook DC/DC Converters
- Multiphase Vcore and DDR Solutions
- Point-of-Load Synchronous Buck in Networking, Telecom, and Computing Systems

3 Description

The CSD97395Q4M NexFET™ Power Stage is a highly optimized design for use in a high-power, high-density synchronous buck converter. This product integrates the driver IC and NexFET technology to complete the power stage switching function. The driver IC has a built-in selectable diode emulation function that enables DCM operation to improve light load efficiency. In addition, the driver IC supports ULQ mode that enables connected standby for Windows® 8. With the PWM input in tri-state, quiescent current is reduced to 130 μ A, with immediate response. When SKIP# is held at tri-state, the current is reduced to 8 μ A (typically 20 μ s is required to resume switching). This combination produces a high current, high efficiency, and high speed switching device in a small 3.5 x 4.5 mm outline package. In addition, the PCB footprint is optimized to help reduce design time and simplify the completion of the overall system design.

Device Information⁽¹⁾

ORDER NUMBER	PACKAGE	MEDIA AND QTY
CSD97395Q4M	SON 3.5 x 4.5 mm Plastic Package	13-inch reel 2500
CSD97395Q4MT		7-inch reel 250

(1) For all available packages, see the orderable addendum at the end of the data sheet.

Application Diagram

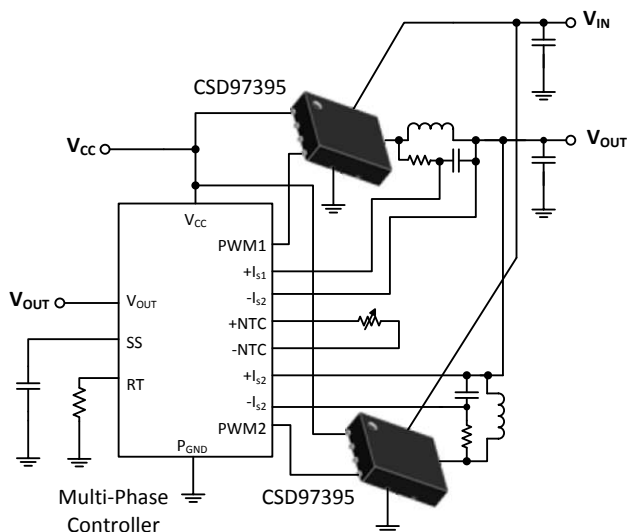

Typical Power Stage Efficiency and Power Loss

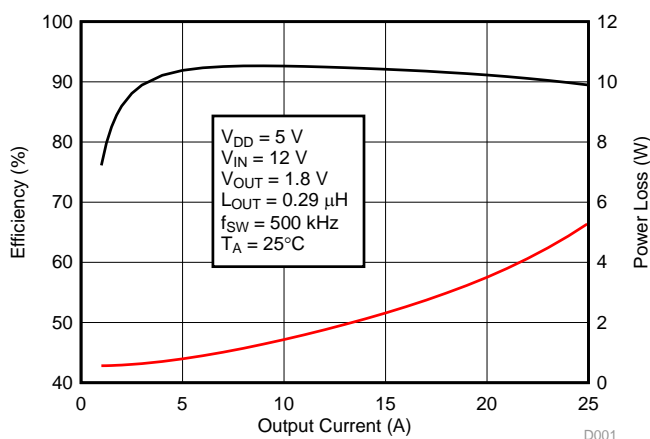

Table of Contents

1 Features	1	8 Application and Implementation	9
2 Applications	1	8.1 Application Information.....	9
3 Description	1	8.2 Typical Application	9
4 Revision History	2	8.3 System Example	11
5 Pin Configuration and Functions	3	9 Layout	14
6 Specifications	4	9.1 Layout Guidelines	14
6.1 Absolute Maximum Ratings	4	9.2 Layout Example	14
6.2 ESD Ratings.....	4	9.3 Thermal Considerations	14
6.3 Recommended Operating Conditions	4	10 Device and Documentation Support	15
6.4 Thermal Information	4	10.1 Trademarks	15
6.5 Electrical Characteristics.....	5	10.2 Electrostatic Discharge Caution.....	15
7 Detailed Description	6	10.3 Glossary	15
7.1 Overview	6	11 Mechanical, Packaging, and Orderable Information	16
7.2 Functional Block Diagram	6	11.1 Mechanical Drawing.....	16
7.3 Feature Description.....	6	11.2 Recommended PCB Land Pattern.....	17
7.4 Device Functional Modes.....	8	11.3 Recommended Stencil Opening	17

4 Revision History

Changes from Original (December 2014) to Revision A

Page

• Figure 11 updated to show normalized Power Loss vs. Output Inductance	11
---	-----------

5 Pin Configuration and Functions

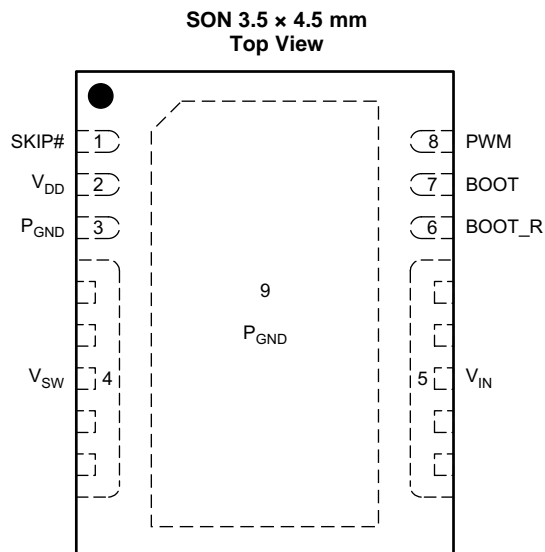

Pin Functions

PIN		DESCRIPTION
NO.	NAME	
1	SKIP#	This pin enables the Diode Emulation function. When this pin is held Low, Diode Emulation Mode is enabled for the Sync FET. When SKIP# is High, the CSD97395Q4M operates in Forced Continuous Conduction Mode. A tri-state voltage on SKIP# puts the driver into a very low power state.
2	V _{DD}	Supply Voltage to Gate Drivers and internal circuitry.
3	P _{GND}	Power Ground, Needs to be connected to Pin 9 and PCB
4	V _{SW}	Voltage Switching Node – pin connection to the output inductor.
5	V _{IN}	Input Voltage Pin. Connect input capacitors close to this pin.
6	BOOT_R	Bootstrap capacitor connection. Connect a minimum 0.1 μ F 16 V X5R, ceramic cap from BOOT to BOOT_R pins. The bootstrap capacitor provides the charge to turn on the Control FET. The bootstrap diode is integrated. Boot_R is internally connected to V _{SW} .
7	BOOT	
8	PWM	Pulse Width modulated 3-state input from external controller. Logic Low sets Control FET gate low and Sync FET gate high. Logic High sets Control FET gate high and Sync FET gate Low. Open or High Z sets both MOSFET gates low if greater than the Tri-State Shutdown Hold-off Time (t_{3HT})
9	P _{GND}	Power Ground

6 Specifications

6.1 Absolute Maximum Ratings

 $T_A = 25^\circ\text{C}$ (unless otherwise noted)⁽¹⁾

	MIN	MAX	UNIT
V_{IN} to P_{GND}	-0.3	30	V
V_{SW} to P_{GND} , V_{IN} to V_{SW}	-0.3	30	V
V_{SW} to P_{GND} , V_{IN} to V_{SW} (<10 ns)	-7	33	V
V_{DD} to P_{GND}	-0.3	6	V
PWM, SKIP# to P_{GND}	-0.3	6	V
BOOT to P_{GND}	-0.3	35	V
BOOT to P_{GND} (<10 ns)	-2	38	V
BOOT to BOOT_R	-0.3	6	V
BOOT to BOOT_R (duty cycle <0.2%)		8	V
P_D Power Dissipation		8	W
T_J Operating Temperature	-40	150	$^\circ\text{C}$
T_{stg} Storage temperature range	-55	150	$^\circ\text{C}$

(1) Stresses above those listed in *Absolute Maximum Ratings* may cause permanent damage to the device. These are stress ratings only and functional operation of the device at these or any other conditions beyond those indicated under *Recommended Operating Conditions* is not implied. Exposure to Absolute Maximum rated conditions for extended periods may affect device reliability.

6.2 ESD Ratings

	VALUE	UNIT
$V_{(ESD)}$ Electrostatic discharge	Human Body Model (HBM) ⁽¹⁾	± 2000
	Charged Device Model (CDM) ⁽²⁾	± 500

(1) JEDEC document JEP155 states that 500 V HBM allows safe manufacturing with a standard ESD control process.

(2) JEDEC document JEP157 states that 250 V CDM allows safe manufacturing with a standard ESD control process.

6.3 Recommended Operating Conditions

 $T_A = 25^\circ\text{C}$ (unless otherwise noted)

	MIN	MAX	UNIT
V_{DD} Gate Drive Voltage	4.5	5.5	V
V_{IN} Input Supply Voltage ⁽¹⁾		24	V
I_{OUT} Continuous Output Current	$V_{IN} = 12\text{ V}$, $V_{DD} = 5\text{ V}$, $V_{OUT} = 1.8\text{ V}$, $f_{SW} = 500\text{ kHz}$, $L_{OUT} = 0.29\text{ }\mu\text{H}$ ⁽²⁾		25
I_{OUT-PK} Peak Output Current ⁽³⁾			60
f_{SW} Switching Frequency	$C_{BST} = 0.1\text{ }\mu\text{F}$ (min)		2000
On-Time Duty Cycle			85%
Minimum PWM On-Time	40		ns
Operating Temperature	-40	125	$^\circ\text{C}$

(1) Operating at high V_{IN} can create excessive AC voltage overshoots on the switch node (V_{SW}) during MOSFET switching transients. For reliable operation, the switch node (V_{SW}) to ground voltage must remain at or below the *Absolute Maximum Ratings*.

(2) Measurement made with six 10 μF (TDK C3216X5R1C106KT or equivalent) ceramic capacitors placed across V_{IN} to P_{GND} pins.

(3) System conditions as defined in Note 2. Peak Output Current is applied for $t_p = 10\text{ ms}$, duty cycle $\leq 1\%$

6.4 Thermal Information

 $T_A = 25^\circ\text{C}$ (unless otherwise noted)

THERMAL METRIC		MIN	TYP	MAX	UNIT
$R_{\theta JC}$	Junction-to-Case Thermal Resistance (Top of package) ⁽¹⁾		22.8		$^\circ\text{C/W}$
$R_{\theta JB}$	Junction-to-Board Thermal Resistance ⁽²⁾		2.5		

(1) $R_{\theta JC}$ is determined with the device mounted on a 1 inch² (6.45 cm²), 2 oz (0.071 mm thick) Cu pad on a 1.5 inch x 1.5 inch, 0.06 inch (1.52 mm) thick FR4 board.

(2) $R_{\theta JB}$ value based on hottest board temperature within 1 mm of the package.

6.5 Electrical Characteristics

 $T_A = 25^\circ\text{C}$, $V_{DD} = \text{POR to } 5.5\text{V}$ (unless otherwise noted)

PARAMETER		TEST CONDITIONS	MIN	TYP	MAX	UNIT
P_{Loss}						
Power Loss ⁽¹⁾		$V_{IN} = 12\text{ V}$, $V_{DD} = 5\text{ V}$, $V_{OUT} = 1.8\text{ V}$, $I_{OUT} = 15\text{ A}$, $f_{SW} = 500\text{ kHz}$, $L_{OUT} = 0.29\text{ }\mu\text{H}$, $T_J = 25^\circ\text{C}$		2.3		W
Power Loss ⁽²⁾		$V_{IN} = 19\text{ V}$, $V_{DD} = 5\text{ V}$, $V_{OUT} = 1.8\text{ V}$, $I_{OUT} = 15\text{ A}$, $f_{SW} = 500\text{ kHz}$, $L_{OUT} = 0.29\text{ }\mu\text{H}$, $T_J = 25^\circ\text{C}$		2.5		W
Power Loss ⁽²⁾		$V_{IN} = 19\text{ V}$, $V_{DD} = 5\text{ V}$, $V_{OUT} = 1.8\text{ V}$, $I_{OUT} = 15\text{ A}$, $f_{SW} = 500\text{ kHz}$, $L_{OUT} = 0.29\text{ }\mu\text{H}$, $T_J = 125^\circ\text{C}$		2.8		W
V_{IN}						
I_Q	V_{IN} Quiescent Current	PWM=Floating, $V_{DD} = 5\text{ V}$, $V_{IN} = 24\text{ V}$			1	μA
V_{DD}						
I_{DD}	Standby Supply Current	PWM = Float, SKIP# = V_{DD} or 0 V		130		μA
		SKIP# = Float		8		μA
I_{DD}	Operating Supply Current	PWM = 50% Duty cycle, $f_{SW} = 500\text{ kHz}$		8.2		mA
POWER-ON RESET AND UNDERVOLTAGE LOCKOUT						
V_{DD} Rising	Power-On Reset				4.15	V
V_{DD} Falling	UVLO		3.7			V
	Hysteresis			0.2		mV
PWM AND SKIP# I/O SPECIFICATIONS						
R_I	Input Impedance	Pull Up to V_{DD}		1700		k Ω
		Pull Down (to GND)		800		
V_{IH}	Logic Level High		2.65			V
V_{IL}	Logic Level Low			0.6		
V_{IH}	Hysteresis			0.2		
V_{TS}	Tri-State Voltage		1.3		2	
$t_{THOLD(off1)}$	Tri-state Activation Time (falling) PWM ⁽²⁾			60		ns
$t_{THOLD(off2)}$	Tri-state Activation Time (rising) PWM ⁽²⁾			60		
t_{TSKF}	Tri-state Activation Time (falling) SKIP# ⁽²⁾			1		μs
t_{TSKR}	Tri-state Activation Time (rising) SKIP# ⁽²⁾			1		
$t_{3RD(PWM)}$	Tri-state Exit Time PWM ⁽²⁾				100	ns
$t_{3RD(SKIP\#)}$	Tri-state Exit Time SKIP# ⁽²⁾				50	μs
BOOTSTRAP SWITCH						
V_{FBST}	Forward Voltage	$I_F = 10\text{ mA}$		120	240	mV
I_{RLEAK}	Reverse Leakage ⁽²⁾	$V_{BST} - V_{DD} = 25\text{ V}$			2	μA

(1) Measurement made with six 10 μF (TDK C3216X5R1C106KT or equivalent) ceramic capacitors placed across V_{IN} to P_{GND} pins.

(2) Specified by design.

7 Detailed Description

7.1 Overview

The CSD97395Q4M NexFET™ Power Stage is a highly optimized design for use in a high-power, high-density synchronous buck converter.

7.2 Functional Block Diagram

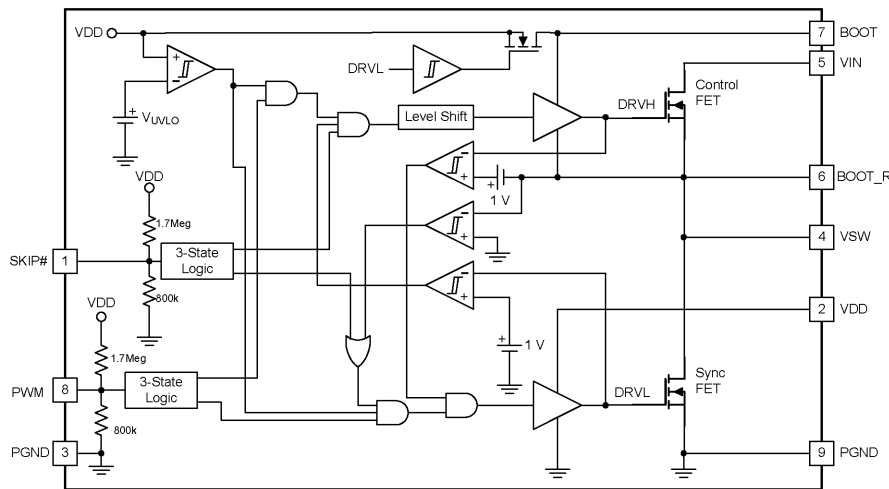

7.3 Feature Description

7.3.1 Powering CSD97395Q4M and Gate Drivers

An external V_{DD} voltage is required to supply the integrated gate driver IC and provide the necessary gate drive power for the MOSFETS. A 1 μ F 10 V X5R or higher ceramic capacitor is recommended to bypass V_{DD} pin to P_{GND} . A bootstrap circuit to provide gate drive power for the Control FET is also included. The bootstrap supply to drive the Control FET is generated by connecting a 100 nF 16 V X5R ceramic capacitor between BOOT and BOOT_R pins. An optional R_{BOOT} resistor can be used to slow down the turn on speed of the Control FET and reduce voltage spikes on the V_{SW} node. A typical 1 Ω to 4.7 Ω value is a compromise between switching loss and V_{SW} spike amplitude.

7.3.2 Undervoltage Lockout (UVLO) Protection

The undervoltage lockout (UVLO) comparator evaluates the V_{DD} voltage level. As V_{DD} rises, both the Control FET and Sync FET gates hold actively low at all times until V_{DD} reaches the higher UVLO threshold (V_{UVLO_H}). Then the driver becomes operational and responds to PWM and SKIP# commands. If V_{DD} falls below the lower UVLO threshold ($V_{UVLO_L} = V_{UVLO_H} - \text{Hysteresis}$), the device disables the driver and drives the outputs of the Control FET and Sync FET gates actively low. [Figure 1](#) shows this function.

CAUTION

Do not start the driver in the very low power mode (SKIP# = Tri-state).

Feature Description (continued)

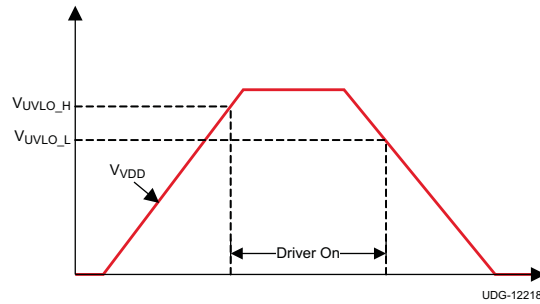

Figure 1. UVLO Operation

7.3.3 PWM Pin

The PWM pin incorporates an input tri-state function. The device forces the gate driver outputs to low when PWM is driven into the tri-state window and the driver enters a low power state with zero exit latency. The pin incorporates a weak pull-up to maintain the voltage within the tri-state window during low-power modes. Operation into and out of tri-state mode follows the timing diagram outlined in Figure 2.

When VDD reaches the UVLO_H level, a tri-state voltage range (window) is set for the PWM input voltage. The window is defined the PWM voltage range between PWM logic high (V_{IH}) and logic low (V_{IL}) thresholds. The device sets high-level input voltage and low-level input voltage threshold levels to accommodate both 3.3 V (typical) and 5 V (typical) PWM drive signals.

When the PWM exits tri-state, the driver enters CCM for a period of 4 μ s, regardless of the state of the SKIP# pin. Normal operation requires this time period in order for the auto-zero comparator to resume.

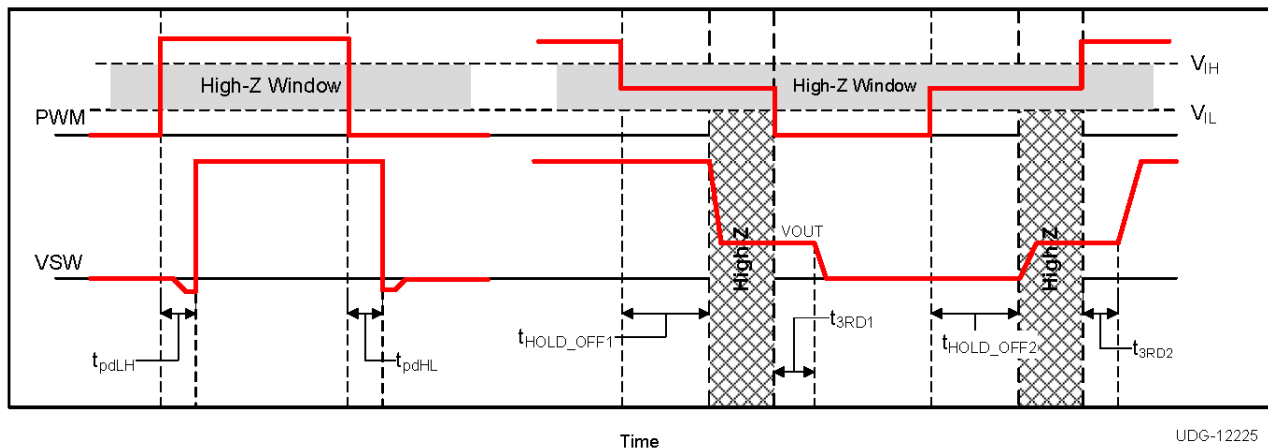

Figure 2. PWM Tri-State Timing Diagram

7.3.4 SKIP# Pin

The SKIP# pin incorporates the input tri-state buffer as PWM. The function is somewhat different. When SKIP# is low, the zero crossing (ZX) detection comparator is enabled, and DCM mode operation occurs if the load current is less than the critical current. When SKIP# is high, the ZX comparator disables, and the converter enters FCCM mode. When both SKIP# and PWM are tri-stated, normal operation forces the gate driver outputs low and the driver enters a low-power state. In the low-power state, the UVLO comparator remains off to reduce quiescent current. When SKIP# is pulled low, the driver wakes up and is able to accept PWM pulses in less than 50 μ s.

Feature Description (continued)

Table 1 shows the logic functions of UVLO, PWM, SKIP#, the Control FET Gate and the Sync FET Gate.

Table 1. Logic Functions of the Driver IC

UVLO	PWM	SKIP#	Sync FET Gate	Control FET Gate	MODE
Active	—	—	Low	Low	Disabled
Inactive	Low	Low	High ⁽¹⁾	Low	DCM ⁽¹⁾
Inactive	Low	High	High	Low	FCCM
Inactive	High	H or L	Low	High	
Inactive	Tri-state	H or L	Low	Low	LQ
Inactive	—	Tri-state	Low	Low	ULQ

(1) Until zero crossing protection occurs.

7.3.4.1 Zero Crossing (ZX) Operation

The zero crossing comparator is adaptive for improved accuracy. As the output current decreases from a heavy load condition, the inductor current also reduces and eventually arrives at a *valley*, where it touches zero current, which is the boundary between continuous conduction and discontinuous conduction modes. The SW pin detects the zero-current condition. When this zero inductor current condition occurs, the ZX comparator turns off the rectifying MOSFET.

7.3.5 Integrated Boost-Switch

To maintain a BST-SW voltage close to VDD (to get lower conduction losses on the high-side FET), the conventional diode between the VDD pin and the BST pin is replaced by a FET which is gated by the DRV1 signal.

7.4 Device Functional Modes

Table 1 shows the different functional modes of CSD97395. The diode emulation mode is enabled with SKIP# pulled low, which improves light load efficiency. With PWM in tri-state, Power Stage enters LQ mode and the quiescent current is reduced to 130 μ A. When SKIP# is held in tri-state, ULQ mode is enabled and the current is decreased to 8 μ A.

8 Application and Implementation

NOTE

Information in the following applications sections is not part of the TI component specification, and TI does not warrant its accuracy or completeness. TI's customers are responsible for determining suitability of components for their purposes. Customers should validate and test their design implementation to confirm system functionality.

8.1 Application Information

The Power Stage CSD97395Q4M is a highly optimized design for synchronous buck applications using NexFET devices with a 5 V gate drive. The Control FET and Sync FET silicon are parametrically tuned to yield the lowest power loss and highest system efficiency. As a result, a rating method is used that is tailored towards a more systems centric environment. The high-performance gate driver IC integrated in the package helps minimize the parasitics and results in extremely fast switching of the power MOSFETs. System level performance curves such as Power Loss, SOA, and normalized graphs allow engineers to predict the product performance in the actual application.

8.2 Typical Application

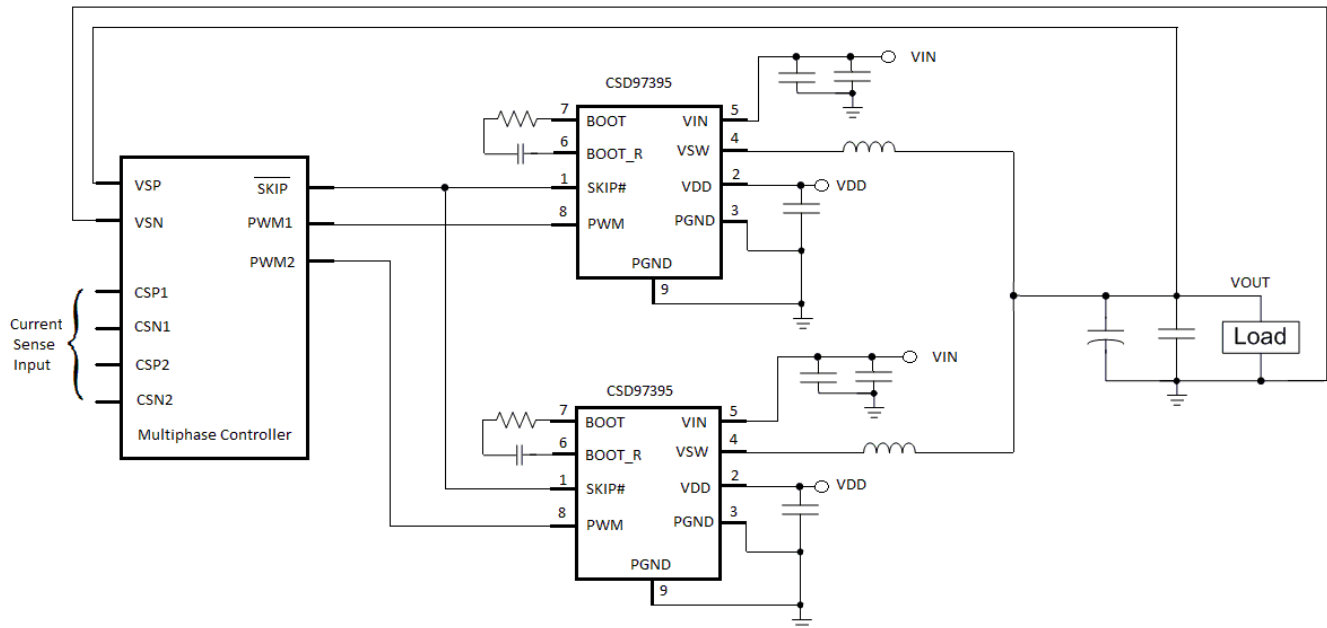

Figure 3. Application Schematic

8.2.1 Application Curves

$T_J = 125^\circ\text{C}$, unless stated otherwise.

Typical Application (continued)

T_J = 125°C, unless stated otherwise.

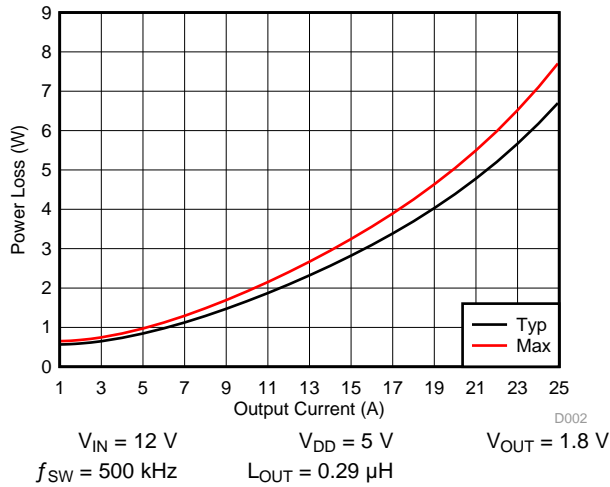

Figure 4. Power Loss vs Output Current

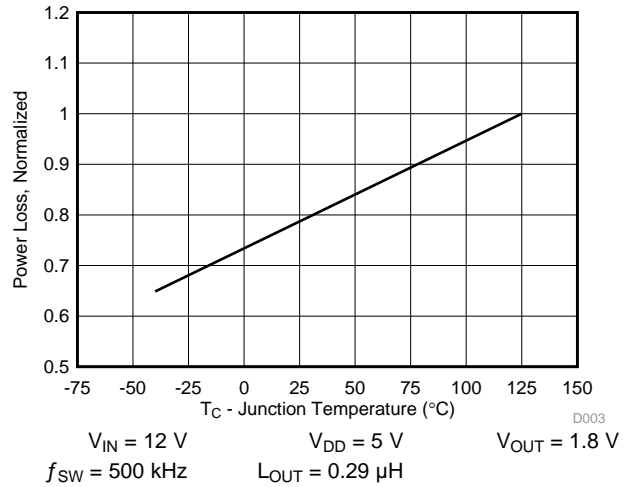

Figure 5. Power Loss vs Temperature

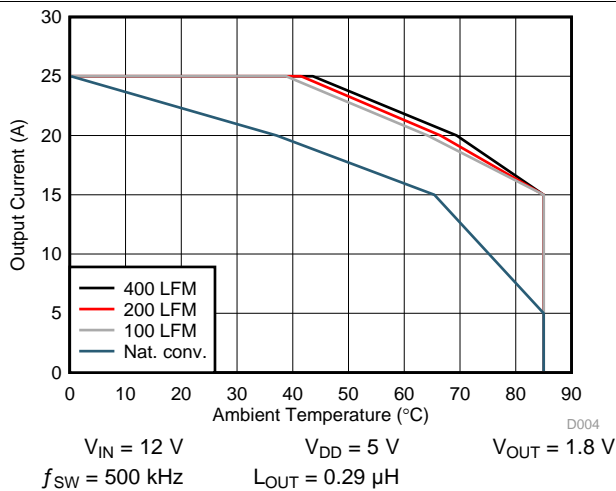

Figure 6. Safe Operating Area – PCB Horizontal Mount ⁽¹⁾

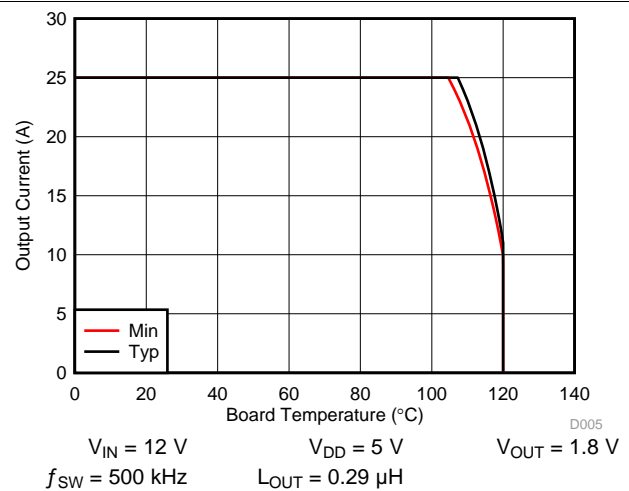

Figure 7. Typical Safe Operating Area ⁽¹⁾

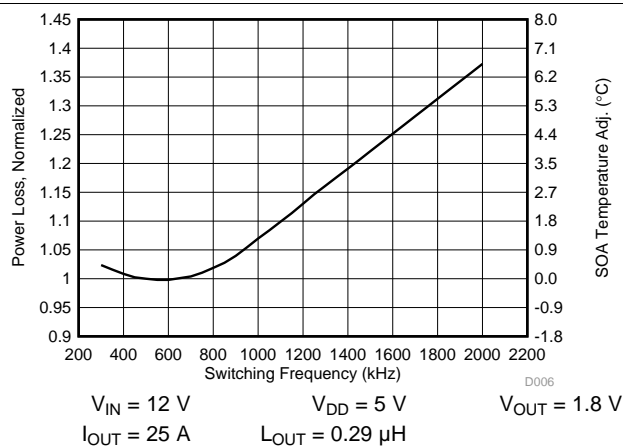

Figure 8. Normalized Power Loss vs Frequency

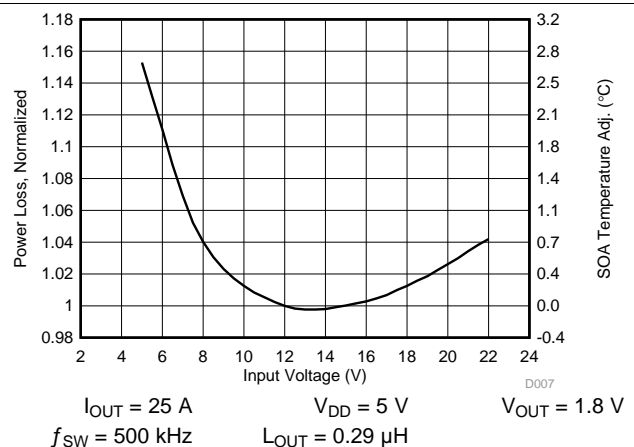
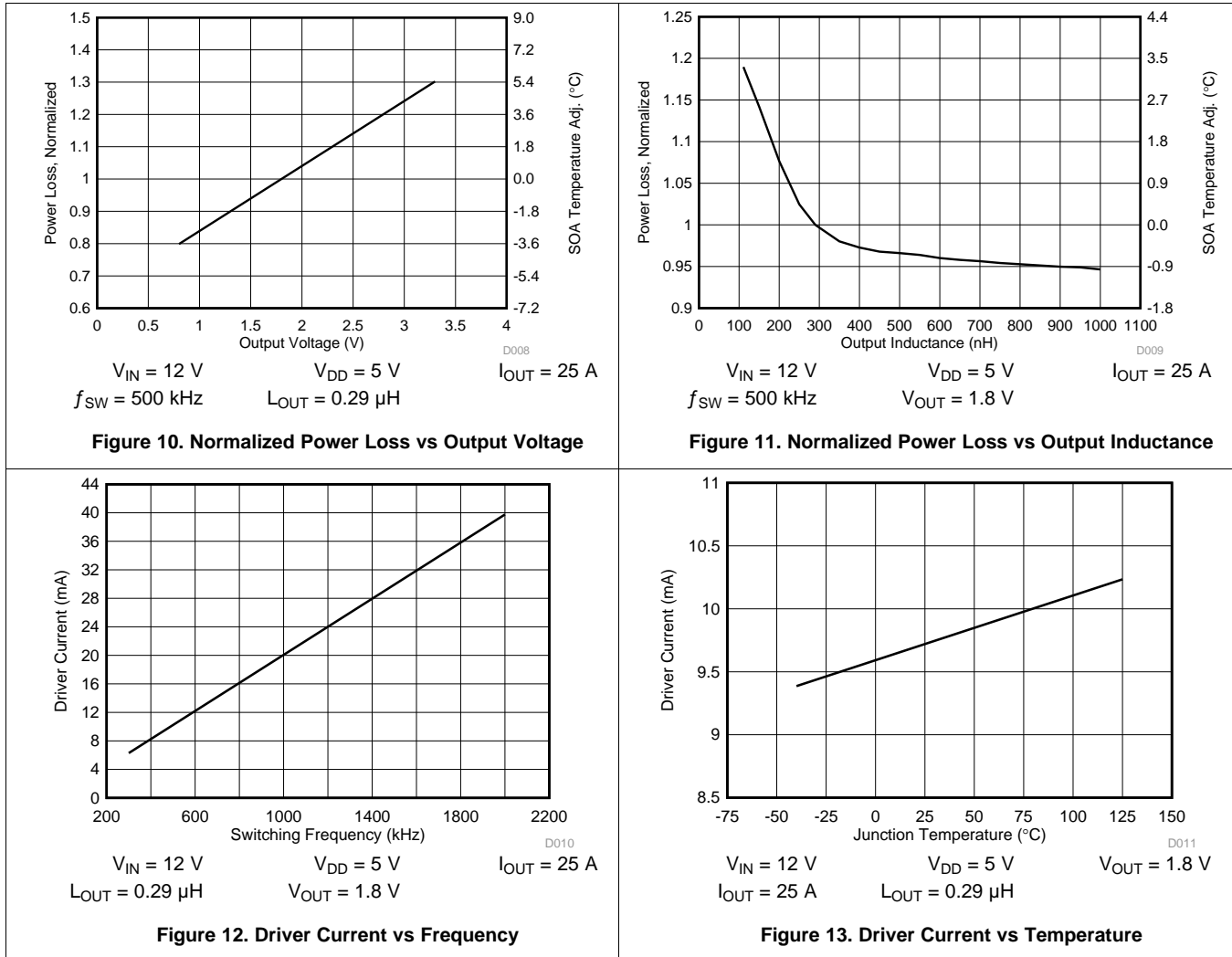

Figure 9. Normalized Power Loss vs Input Voltage

Typical Application (continued)

T_J = 125°C, unless stated otherwise.



1. The Typical CSD97395Q4M System Characteristic curves are based on measurements made on a PCB design with dimensions of 4.0" (W) × 3.5" (L) × 0.062" (T) and 6 copper layers of 1 oz. copper thickness. See [System Example](#) for detailed explanation.

8.3 System Example

8.3.1 Power Loss Curves

MOSFET centric parameters such as R_{DS(ON)} and Q_{gd} are primarily needed by engineers to estimate the loss generated by the devices. In an effort to simplify the design process for engineers, Texas Instruments has provided measured power loss performance curves. [Figure 4](#) plots the power loss of the CSD97395Q4M as a function of load current. This curve is measured by configuring and running the CSD97395Q4M as it would be in the final application (see [Figure 14](#)). The measured power loss is the CSD97395Q4M device power loss which consists of both input conversion loss and gate drive loss. [Equation 1](#) is used to generate the power loss curve.

$$\text{Power Loss} = (V_{IN} \times I_{IN}) + (V_{DD} \times I_{DD}) - (V_{SW_AVG} \times I_{OUT}) \tag{1}$$

The power loss curve in [Figure 4](#) is measured at the maximum recommended junction temperature of T_J = 125°C under isothermal test conditions.

System Example (continued)

8.3.4 Calculating Power Loss and SOA

The user can estimate product loss and SOA boundaries by arithmetic means (see the [Design Example](#)). Though the Power Loss and SOA curves in this datasheet are taken for a specific set of test conditions, the following procedure will outline the steps engineers should take to predict product performance for any set of system conditions.

8.3.4.1 Design Example

Operating Conditions: Output Current (I_{OUT}) = 15 A, Input Voltage (V_{IN}) = 7 V, Output Voltage (V_{OUT}) = 1.5 V, Switching Frequency (f_{SW}) = 800 kHz, Output Inductor (L_{OUT}) = 0.2 μ H

8.3.4.2 Calculating Power Loss

- Typical Power Loss at 15 A = 2.8 W ([Figure 4](#))
- Normalized Power Loss for switching frequency \approx 1.02 ([Figure 8](#))
- Normalized Power Loss for input voltage \approx 1.07 ([Figure 9](#))
- Normalized Power Loss for output voltage \approx 0.94 ([Figure 10](#))
- Normalized Power Loss for output inductor \approx 1.08 ([Figure 11](#))
- **Final calculated Power Loss = 2.8 W \times 1.02 \times 1.07 \times 0.94 \times 1.08 \approx 3.1 W**

8.3.4.3 Calculating SOA Adjustments

- SOA adjustment for switching frequency \approx 0.3°C ([Figure 8](#))
- SOA adjustment for input voltage \approx 1.2°C ([Figure 9](#))
- SOA adjustment for output voltage \approx -1.1°C ([Figure 10](#))
- SOA adjustment for output inductor \approx 1.4°C ([Figure 11](#))
- **Final calculated SOA adjustment = 0.3 + 1.2 + (-1.1) + 1.4 \approx 1.8°C**

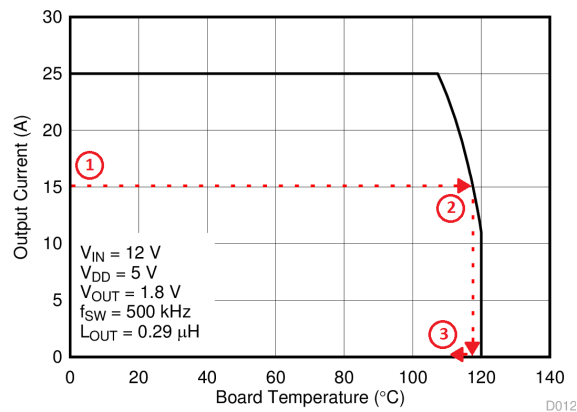

Figure 15. Power Stage CSD97395Q4M SOA

In the design example above, the estimated power loss of the CSD97395Q4M would increase to 3.1 W. In addition, the maximum allowable board and/or ambient temperature would have to decrease by 1.8°C. [Figure 15](#) graphically shows how the SOA curve would be adjusted accordingly.

1. Start by drawing a horizontal line from the application current to the SOA curve.
2. Draw a vertical line from the SOA curve intercept down to the board/ambient temperature.
3. Adjust the SOA board/ambient temperature by subtracting the temperature adjustment value.

In the design example, the SOA temperature adjustment yields a reduction in allowable board/ambient temperature of 1.8°C. In the event the adjustment value is a negative number, subtracting the negative number would yield an increase in allowable board/ambient temperature.

9 Layout

9.1 Layout Guidelines

9.1.1 Recommended PCB Design Overview

There are two key system-level parameters that can be addressed with a proper PCB design: electrical and thermal performance. Properly optimizing the PCB layout will yield maximum performance in both areas. Below is a brief description on how to address each parameter.

9.1.2 Electrical Performance

The CSD97395Q4M has the ability to switch at voltage rates greater than 10 kV/μs. Special care must be then taken with the PCB layout design and placement of the input capacitors, inductor and output capacitors.

- The placement of the input capacitors relative to V_{IN} and P_{GND} pins of CSD97395Q4M device should have the highest priority during the component placement routine. It is critical to minimize these node lengths. As such, ceramic input capacitors need to be placed as close as possible to the V_{IN} and P_{GND} pins (see [Figure 16](#)). The example in [Figure 16](#) uses 1 × 1 nF 0402 25 V and 3 × 10 μF 1206 25 V ceramic capacitors (TDK Part # C3216X5R1C106KT or equivalent). Notice there are ceramic capacitors on both sides of the board with an appropriate amount of vias interconnecting both layers. In terms of priority of placement next to the Power Stage C5, C8 and C6, C19 should follow in order.
- The bootstrap cap C_{BOOT} 0.1 μF 0603 16 V ceramic capacitor should be closely connected between BOOT and BOOT_R pins
- The switching node of the output inductor should be placed relatively close to the Power Stage CSD97395Q4M V_{SW} pins. Minimizing the V_{SW} node length between these two components will reduce the PCB conduction losses and actually reduce the switching noise level. ⁽¹⁾

9.2 Layout Example

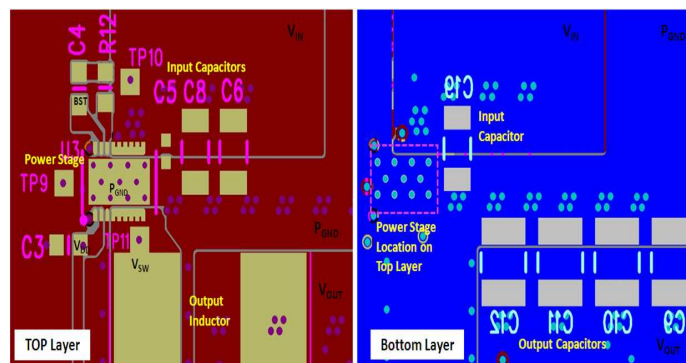

Figure 16. Recommended PCB Layout (Top Down View)

9.3 Thermal Considerations

The CSD97395Q4M has the ability to use the GND planes as the primary thermal path. As such, the use of thermal vias is an effective way to pull away heat from the device and into the system board. Concerns of solder voids and manufacturability problems can be addressed by the use of three basic tactics to minimize the amount of solder attach that will wick down the via barrel:

- Intentionally space out the vias from each other to avoid a cluster of holes in a given area.
- Use the smallest drill size allowed in your design. The example in [Figure 16](#) uses vias with a 10 mil drill hole and a 16 mil capture pad.
- Tent the opposite side of the via with solder-mask.

In the end, the number and drill size of the thermal vias should align with the end user's PCB design rules and manufacturing capabilities.

(1) Keong W. Kam, David Pommerenke, "EMI Analysis Methods for Synchronous Buck Converter EMI Root Cause Analysis", University of Missouri – Rolla

10 Device and Documentation Support

10.1 Trademarks

NexFET is a trademark of Texas Instruments.
Windows is a registered trademark of Microsoft Corporation.
All other trademarks are the property of their respective owners.

10.2 Electrostatic Discharge Caution



These devices have limited built-in ESD protection. The leads should be shorted together or the device placed in conductive foam during storage or handling to prevent electrostatic damage to the MOS gates.

10.3 Glossary

[SLYZ022](#) — *TI Glossary*.

This glossary lists and explains terms, acronyms, and definitions.

11 Mechanical, Packaging, and Orderable Information

The following pages include mechanical, packaging, and orderable information. This information is the most current data available for the designated devices. This data is subject to change without notice and revision of this document. For browser-based versions of this data sheet, refer to the left-hand navigation.

11.1 Mechanical Drawing

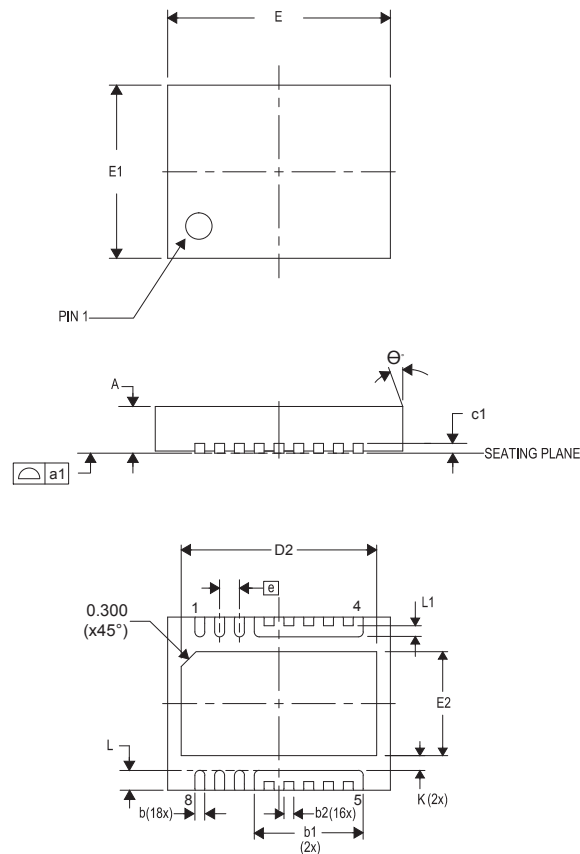

DIM	MILLIMETERS			INCHES		
	MIN	NOM	MAX	MIN	NOM	MAX
A	0.800	0.900	1.000	0.031	0.035	0.039
a1	0.000	0.000	0.080	0.000	0.000	0.003
b	0.150	0.200	0.250	0.006	0.008	0.010
b1	2.000	2.200	2.400	0.079	0.087	0.095
b2	0.150	0.200	0.250	0.006	0.008	0.010
c1	0.150	0.200	0.250	0.006	0.008	0.010
D2	3.850	3.950	4.050	0.152	0.156	0.160
E	4.400	4.500	4.600	0.173	0.177	0.181
E1	3.400	3.500	3.600	0.134	0.138	0.142
E2	2.000	2.100	2.200	0.079	0.083	0.087
e	0.400 TYP			0.016 TYP		
K	0.300 TYP			0.012 TYP		
L	0.300	0.400	0.500	0.012	0.016	0.020
L1	0.180	0.230	0.280	0.007	0.009	0.011
θ	0.00	—	—	0.00	—	—

11.2 Recommended PCB Land Pattern

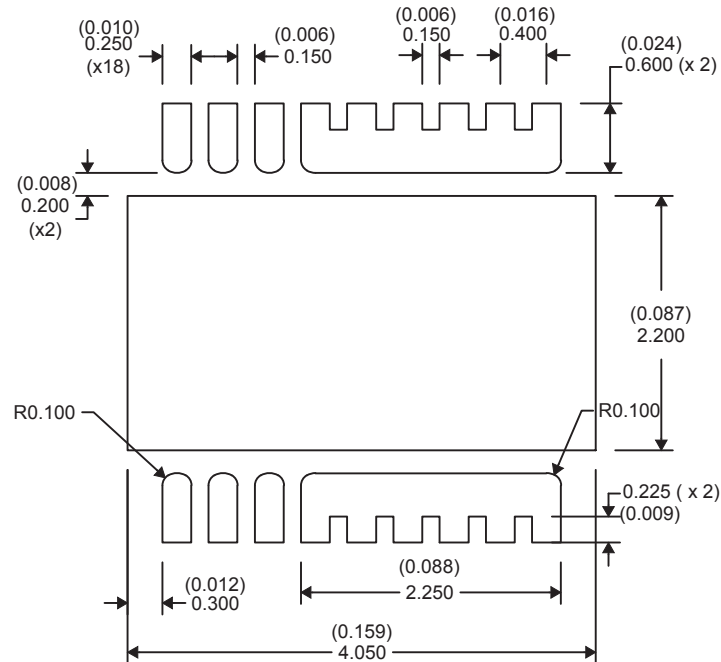

11.3 Recommended Stencil Opening

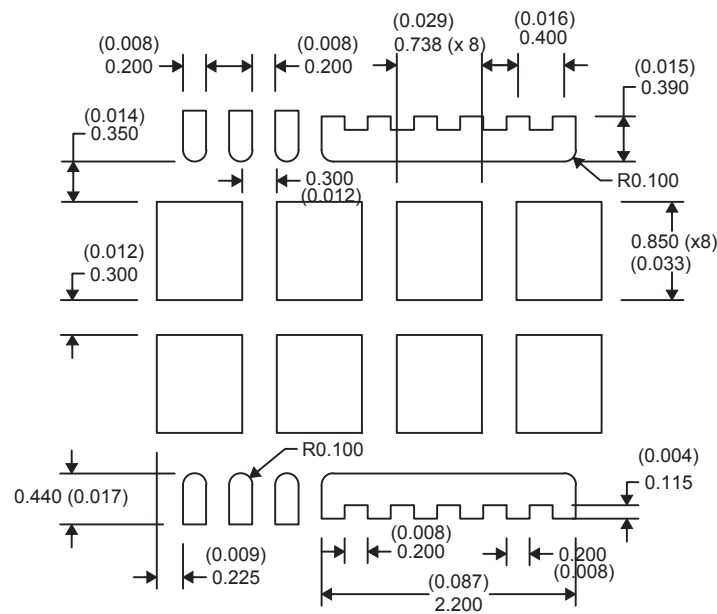

NOTE: Dimensions are in mm (inches).
Stencil is 100 µm thick.

PACKAGING INFORMATION

Orderable Device	Status (1)	Package Type	Package Drawing	Pins	Package Qty	Eco Plan (2)	Lead finish/ Ball material (6)	MSL Peak Temp (3)	Op Temp (°C)	Device Marking (4/5)	Samples
CSD97395Q4M	ACTIVE	VSON-CLIP	DPC	8	2500	RoHS-Exempt & Green	NIPDAU SN	Level-2-260C-1 YEAR	-40 to 150	97395M	Samples
CSD97395Q4MT	ACTIVE	VSON-CLIP	DPC	8	250	RoHS-Exempt & Green	NIPDAU SN	Level-2-260C-1 YEAR	-40 to 150	97395M	Samples

(1) The marketing status values are defined as follows:

ACTIVE: Product device recommended for new designs.

LIFEBUY: TI has announced that the device will be discontinued, and a lifetime-buy period is in effect.

NRND: Not recommended for new designs. Device is in production to support existing customers, but TI does not recommend using this part in a new design.

PREVIEW: Device has been announced but is not in production. Samples may or may not be available.

OBsolete: TI has discontinued the production of the device.

(2) **RoHS:** TI defines "RoHS" to mean semiconductor products that are compliant with the current EU RoHS requirements for all 10 RoHS substances, including the requirement that RoHS substance do not exceed 0.1% by weight in homogeneous materials. Where designed to be soldered at high temperatures, "RoHS" products are suitable for use in specified lead-free processes. TI may reference these types of products as "Pb-Free".

RoHS Exempt: TI defines "RoHS Exempt" to mean products that contain lead but are compliant with EU RoHS pursuant to a specific EU RoHS exemption.

Green: TI defines "Green" to mean the content of Chlorine (Cl) and Bromine (Br) based flame retardants meet JS709B low halogen requirements of <=1000ppm threshold. Antimony trioxide based flame retardants must also meet the <=1000ppm threshold requirement.

(3) MSL, Peak Temp. - The Moisture Sensitivity Level rating according to the JEDEC industry standard classifications, and peak solder temperature.

(4) There may be additional marking, which relates to the logo, the lot trace code information, or the environmental category on the device.

(5) Multiple Device Markings will be inside parentheses. Only one Device Marking contained in parentheses and separated by a "~" will appear on a device. If a line is indented then it is a continuation of the previous line and the two combined represent the entire Device Marking for that device.

(6) Lead finish/Ball material - Orderable Devices may have multiple material finish options. Finish options are separated by a vertical ruled line. Lead finish/Ball material values may wrap to two lines if the finish value exceeds the maximum column width.

Important Information and Disclaimer:The information provided on this page represents TI's knowledge and belief as of the date that it is provided. TI bases its knowledge and belief on information provided by third parties, and makes no representation or warranty as to the accuracy of such information. Efforts are underway to better integrate information from third parties. TI has taken and continues to take reasonable steps to provide representative and accurate information but may not have conducted destructive testing or chemical analysis on incoming materials and chemicals. TI and TI suppliers consider certain information to be proprietary, and thus CAS numbers and other limited information may not be available for release.

In no event shall TI's liability arising out of such information exceed the total purchase price of the TI part(s) at issue in this document sold by TI to Customer on an annual basis.

TAPE AND REEL INFORMATION

QUADRANT ASSIGNMENTS FOR PIN 1 ORIENTATION IN TAPE

*All dimensions are nominal

Device	Package Type	Package Drawing	Pins	SPQ	Reel Diameter (mm)	Reel Width W1 (mm)	A0 (mm)	B0 (mm)	K0 (mm)	P1 (mm)	W (mm)	Pin1 Quadrant
CSD97395Q4M	VSON-CLIP	DPC	8	2500	330.0	12.4	3.71	4.71	1.1	8.0	12.0	Q1
CSD97395Q4MT	VSON-CLIP	DPC	8	250	180.0	12.4	3.71	4.71	1.1	8.0	12.0	Q1

TAPE AND REEL BOX DIMENSIONS

*All dimensions are nominal

Device	Package Type	Package Drawing	Pins	SPQ	Length (mm)	Width (mm)	Height (mm)
CSD97395Q4M	VSON-CLIP	DPC	8	2500	346.0	346.0	33.0
CSD97395Q4MT	VSON-CLIP	DPC	8	250	210.0	185.0	35.0

IMPORTANT NOTICE AND DISCLAIMER

TI PROVIDES TECHNICAL AND RELIABILITY DATA (INCLUDING DATA SHEETS), DESIGN RESOURCES (INCLUDING REFERENCE DESIGNS), APPLICATION OR OTHER DESIGN ADVICE, WEB TOOLS, SAFETY INFORMATION, AND OTHER RESOURCES "AS IS" AND WITH ALL FAULTS, AND DISCLAIMS ALL WARRANTIES, EXPRESS AND IMPLIED, INCLUDING WITHOUT LIMITATION ANY IMPLIED WARRANTIES OF MERCHANTABILITY, FITNESS FOR A PARTICULAR PURPOSE OR NON-INFRINGEMENT OF THIRD PARTY INTELLECTUAL PROPERTY RIGHTS.

These resources are intended for skilled developers designing with TI products. You are solely responsible for (1) selecting the appropriate TI products for your application, (2) designing, validating and testing your application, and (3) ensuring your application meets applicable standards, and any other safety, security, regulatory or other requirements.

These resources are subject to change without notice. TI grants you permission to use these resources only for development of an application that uses the TI products described in the resource. Other reproduction and display of these resources is prohibited. No license is granted to any other TI intellectual property right or to any third party intellectual property right. TI disclaims responsibility for, and you will fully indemnify TI and its representatives against, any claims, damages, costs, losses, and liabilities arising out of your use of these resources.

TI's products are provided subject to [TI's Terms of Sale](#) or other applicable terms available either on [ti.com](https://www.ti.com) or provided in conjunction with such TI products. TI's provision of these resources does not expand or otherwise alter TI's applicable warranties or warranty disclaimers for TI products.

TI objects to and rejects any additional or different terms you may have proposed.

Mailing Address: Texas Instruments, Post Office Box 655303, Dallas, Texas 75265
Copyright © 2024, Texas Instruments Incorporated

Looking for pricing, stock, or lifecycle information?

Click below to explore more details on WIN SOURCE:

- ⊖ [View S25FL129P0XBHV303 on WIN SOURCE](#)
- ⊖ [Cypress Semiconductor Corp Information](#)

Optimize Your Supply Chain with WIN SOURCE Solutions

- ✓ Global Sourcing Solution
- ✓ Obsolete Management
- ✓ Cost Control Management
- ✓ Shortage Management
- ✓ Alternative Solution
- ✓ Excess Inventory Management