



**THE DATASHEET OF
S25FL129P0XBHI303**





“Spansion, Inc.” and “Cypress Semiconductor Corp.” have merged together to deliver high-performance, high-quality solutions at the heart of today's most advanced embedded systems, from automotive, industrial and networking platforms to highly interactive consumer and mobile devices. The new company “Cypress Semiconductor Corp.” will continue to offer “Spansion, Inc.” products to new and existing customers.

CONTINUITY OF SPECIFICATIONS

There is no change to this document as a result of offering the device as a Cypress product. Any changes that have been made are the result of normal document improvements and are noted in the document history page, where supported. Future revisions will occur when appropriate, and changes will be noted in a document history page.

CONTINUITY OF ORDERING PART NUMBERS

Cypress continues to support existing part numbers. To order these products, please use only the Ordering Part Numbers listed in this document.

FOR MORE INFORMATION

Please visit our website at www.cypress.com or contact your [local sales office](#) for additional information about Cypress products and services.

OUR CUSTOMERS

Cypress is for true innovators – in companies both large and small.

Our customers are smart, aggressive, out-of-the-box thinkers who design and develop game-changing products that revolutionize their industries or create new industries with products and solutions that nobody ever thought of before.

ABOUT CYPRESS

Founded in 1982, Cypress is the leader in advanced embedded system solutions for the world's most innovative automotive, industrial, home automation and appliances, consumer electronics and medical products. Cypress's programmable systems-on-chip, general-purpose microcontrollers, analog ICs, wireless and USB-based connectivity solutions and reliable, high-performance memories help engineers design differentiated products and get them to market first.

Cypress is committed to providing customers with the best support and engineering resources on the planet enabling innovators and out-of-the-box thinkers to disrupt markets and create new product categories in record time. To learn more, go to www.cypress.com.

This product is not recommended for new and current designs. For new and current designs, S25FL128S supersedes S25FL129P. This is the factory-recommended migration path. Please refer to the S25FL128S data sheet for specifications and ordering information.

Distinctive Characteristics

Architectural Advantages

- Single power supply operation
 - Full voltage range: 2.7 to 3.6V read and write operations
- Memory architecture
 - Uniform 64 KB sectors
 - Top or bottom parameter block (Two 64-KB sectors broken down into sixteen 4-KB sub-sectors each)
 - Uniform 256 KB sectors (no 4-KB sub-sectors)
 - 256-byte page size
 - Backward compatible with the S25FL128P (uniform 256 KB sector) device
- Program
 - Page Program (up to 256 bytes) in 1.5 ms (typical)
 - Program operations are on a page by page basis
 - Accelerated programming mode via 9V W#/ACC pin
 - Quad Page Programming
- Erase
 - Bulk erase function
 - Sector erase (SE) command (D8h) for 64 KB and 256 KB sectors
 - Sub-sector erase (P4E) command (20h) for 4 KB sectors (for uniform 64-KB sector device only)
 - Sub-sector erase (P8E) command (40h) for 8 KB sectors (for uniform 64-KB sector device only)
- Cycling endurance
 - 100,000 cycles per sector typical
- Data retention
 - 20 years typical
- Device ID
 - JEDEC standard two-byte electronic signature
 - RES command one-byte electronic signature for backward compatibility

- One time programmable (OTP) area for permanent, secure identification; can be programmed and locked at the factory or by the customer
- CFI (Common Flash Interface) compliant: allows host system to identify and accommodate multiple flash devices
- Process technology
 - Manufactured on 0.09 μm MirrorBit® process technology
- Package option
 - Industry Standard Pinouts
 - 16-pin SO package (300 mils)
 - 8-contact WSON package (6 x 8 mm)
 - 24-ball BGA (6 x 8 mm) package, 5 x 5 pin configuration
 - 24-ball BGA (6 x 8 mm) package, 6 x 4 pin configuration

Performance Characteristics

- Speed
 - Normal READ (Serial): 40 MHz clock rate
 - FAST_READ (Serial): 104 MHz clock rate (maximum)
 - DUAL I/O FAST_READ: 80 MHz clock rate or 20 MB/s effective data rate
 - QUAD I/O FAST_READ: 80 MHz clock rate or 40 MB/s effective data rate
- Power saving standby mode
 - Standby Mode 80 μA (typical)
 - Deep Power-Down Mode 3 μA (typical)

Memory Protection Features

- Memory protection
 - W#/ACC pin works in conjunction with Status Register Bits to protect specified memory areas
 - Status Register Block Protection bits (BP2, BP1, BP0) in status

General Description

The S25FL129P is a 3.0 Volt (2.7V to 3.6V), single-power-supply Flash memory device. The device is offered in two configurations: 256 uniform 64 KB sectors with the two (Top or Bottom) 64 KB sectors further split up into thirty-two 4 KB sub sectors, or 64 uniform 256 KB sectors. The S25FL129P device is backward compatible with the S25FL128P (uniform 256 KB sector) device.

The device accepts data written to SI (Serial Input) and outputs data on SO (Serial Output). The devices are designed to be programmed in-system with the standard system 3.0-volt V_{CC} supply.

The S25FL129P device adds the following high-performance features using 5 new instructions:

- Dual Output Read using both SI and SO pins as output pins at a clock rate of up to 80 MHz
- Quad Output Read using SI, SO, W#/ACC and HOLD# pins as output pins at a clock rate of up to 80 MHz
- Dual I/O High Performance Read using both SI and SO pins as input and output pins at a clock rate of up to 80 MHz
- Quad I/O High Performance Read using SI, SO, W#/ACC and HOLD# pins as input and output pins at a clock rate of up to 80 MHz
- Quad Page Programming using SI, SO, W#/ACC and HOLD# pins as input pins to program data at a clock rate of up to 80 MHz

The memory can be programmed 1 to 256 bytes at a time, using the Page Program command. The device supports Sector Erase and Bulk Erase commands.

Each device requires only a 3.0-volt power supply (2.7V to 3.6V) for both read and write functions. Internally generated and regulated voltages are provided for the program operations. This device requires a high voltage supply to the W#/ACC pin to enable the Accelerated Programming mode.

The S25FL129P device also offers a One-Time Programmable area (OTP) of up to 128-bits (16 bytes) for permanent secure identification and an additional 490 bytes of OTP space for other use. This OTP area can be programmed or read using the OTPP or OTPR instructions.

Contents

Distinctive Characteristics	2	9.14 Page Program (PP).....	39
General Description	3	9.15 QUAD Page Program (QPP)	40
1. Block Diagram	5	9.16 Parameter Sector Erase (P4E, P8E) (only applica- ble for the uniform 64 KB sector device).....	41
2. Connection Diagrams	5	9.17 Sector Erase (SE).....	42
3. Input/Output Descriptions	7	9.18 Bulk Erase (BE)	43
4. Logic Symbol	7	9.19 Deep Power-Down (DP)	44
5. Ordering Information	8	9.20 Release from Deep Power-Down (RES).....	45
5.1 Valid Combinations	8	9.21 Clear Status Register (CLSR).....	46
6. SPI Modes	9	9.22 OTP Program (OTPP).....	47
7. Device Operations	10	9.23 Read OTP Data Bytes (OTPR).....	47
7.1 Byte or Page Programming.....	10	10. OTP Regions	48
7.2 Quad Page Programming	10	10.1 Programming OTP Address Space.....	48
7.3 Dual and Quad I/O Mode	10	10.2 Reading OTP Data	48
7.4 Sector Erase / Bulk Erase.....	10	10.3 Locking OTP Regions.....	48
7.5 Monitoring Write Operations Using the Status Reg- ister	10	11. Power-up and Power-down	51
7.6 Active Power and Standby Power Modes.....	10	12. Initial Delivery State	52
7.7 Status Register	11	13. Program Acceleration via W#/ACC Pin	52
7.8 Configuration Register	11	14. Electrical Specifications	54
7.9 Data Protection Modes	13	14.1 Absolute Maximum Ratings	54
7.10 Hold Mode (HOLD#).....	14	15. Operating Ranges	54
7.11 Accelerated Programming Operation.....	14	16. DC Characteristics	55
8. Sector Address Table	15	17. Test Conditions	56
9. Command Definitions	20	18. AC Characteristics	57
9.1 Read Data Bytes (READ)	22	18.1 Capacitance.....	58
9.2 Read Data Bytes at Higher Speed (FAST_READ)	23	19. Physical Dimensions	60
9.3 Dual Output Read Mode (DOR).....	24	19.1 SO3 016 — 16-pin Wide Plastic Small Outline Package (300-mil Body Width)	60
9.4 Quad Output Read Mode (QOR)	25	19.2 WSON 8-contact (6 x 8 mm) No-Lead Package (WNF008)	61
9.5 DUAL I/O High Performance Read Mode (DIOR).....	26	19.3 FAB024 — 24-ball Ball Grid Array (6 x 8 mm) package	62
9.6 Quad I/O High Performance Read Mode (QIOR)	28	19.4 FAC024 — 24-ball Ball Grid Array (6 x 8 mm) package	63
9.7 Read Identification (RDID).....	29	20. Revision History	64
9.8 Read-ID (READ_ID).....	33		
9.9 Write Enable (WREN).....	34		
9.10 Write Disable (WRDI).....	34		
9.11 Read Status Register (RDSR)	35		
9.12 Read Configuration Register (RCR)	36		
9.13 Write Registers (WRR)	37		

1. Block Diagram

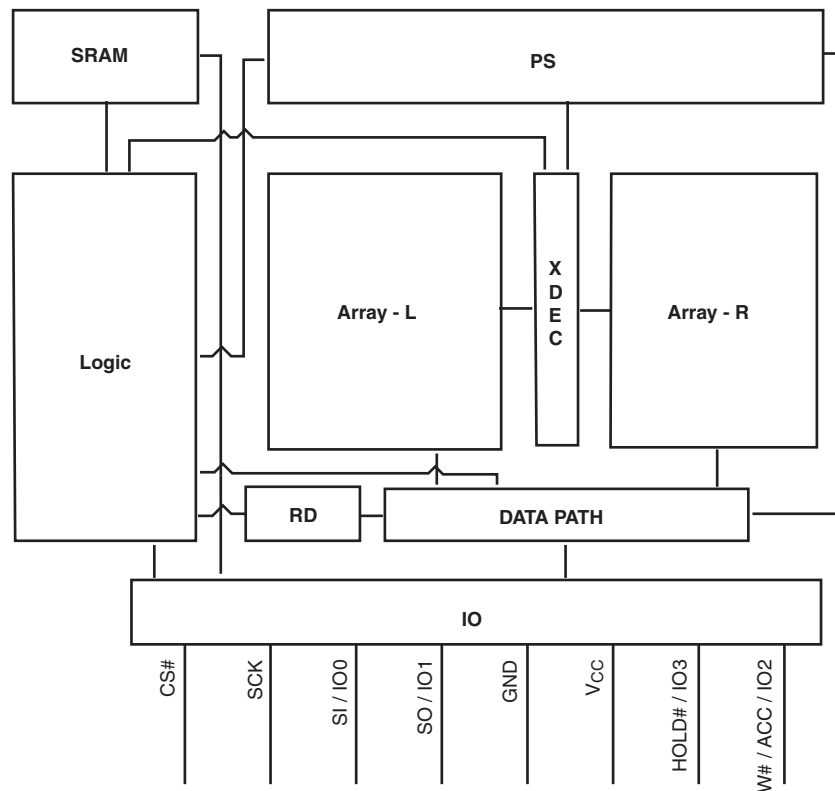

2. Connection Diagrams

Figure 2.1 16-pin Plastic Small Outline Package (SO)

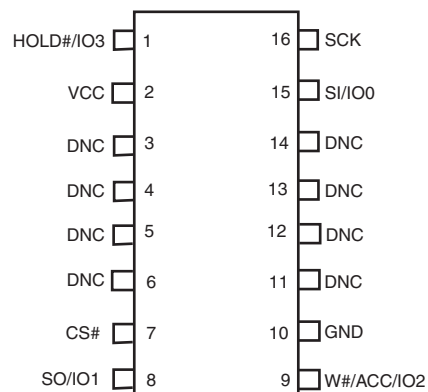

Note
DNC = Do Not Connect (Reserved for future use)

Figure 2.2 8-contact WSON Package (6 x 8 mm)



Note

There is an exposed central pad on the underside of the WSON package. This should not be connected to any voltage or signal line on the PCB. Connecting the central pad to GND (V_{SS}) is possible, provided PCB routing ensures 0mV difference between voltage at the WSON GND (V_{SS}) lead and the central exposed pad.

Figure 2.3 6 x 8 mm 24-ball BGA Package, 5 x 5 Pin Configuration

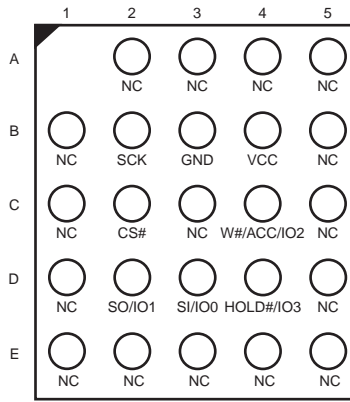
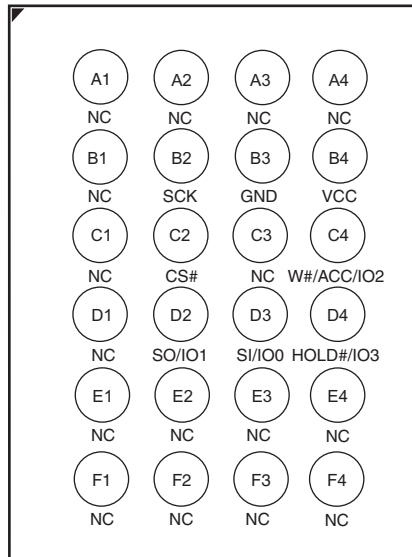

Figure 2.4 6 x 8 mm 24-ball BGA Package, 6 x 4 Pin Configuration



3. Input/Output Descriptions

Signal	I/O	Description
SO/IO1	I/O	Serial Data Output: Transfers data serially out of the device on the falling edge of SCK. Functions as an I/O pin in Dual and Quad I/O, and Quad Page Program modes.
SI/IO0	I/O	Serial Data Input: Transfers data serially into the device. Device latches commands, addresses, and program data on SI on the rising edge of SCK. Functions as an I/O pin in Dual and Quad I/O mode.
SCK	Input	Serial Clock: Provides serial interface timing. Latches commands, addresses, and data on SI on rising edge of SCK. Triggers output on SO after the falling edge of SCK.
CS#	Input	Chip Select: Places device in active power mode when driven low. Deselects device and places SO at high impedance when high. After power-up, device requires a falling edge on CS# before any command is written. Device is in standby mode when a program, erase, or Write Status Register operation is not in progress.
HOLD#/IO3	I/O	Hold: Pauses any serial communication with the device without deselecting it. When driven low, SO is at high impedance, and all input at SI and SCK are ignored. Requires that CS# also be driven low. Functions as an I/O pin in Quad I/O mode.
W#/ACC/IO2	I/O	Write Protect: Protects the memory area specified by Status Register bits BP2:BP0. When driven low, prevents any program or erase command from altering the data in the protected memory area. Functions as an I/O pin in Quad I/O mode.
V _{CC}	Input	Supply Voltage
GND	Input	Ground

4. Logic Symbol

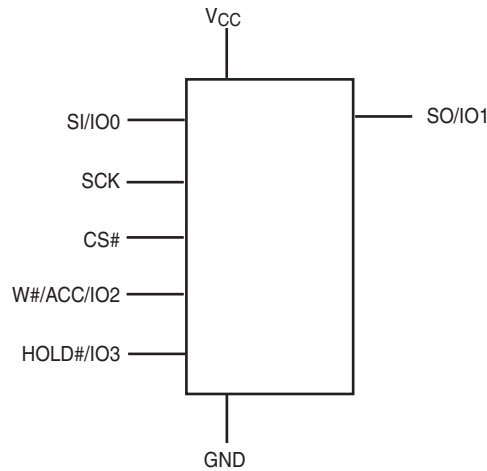

5. Ordering Information

This product is not recommended for new and current designs. For new and current designs, S25FL128S supersedes S25FL129P. This is the factory-recommended migration path. Please refer to the S25FL128S data sheet for specifications and ordering information.

The ordering part number is formed by a valid combination of the following:

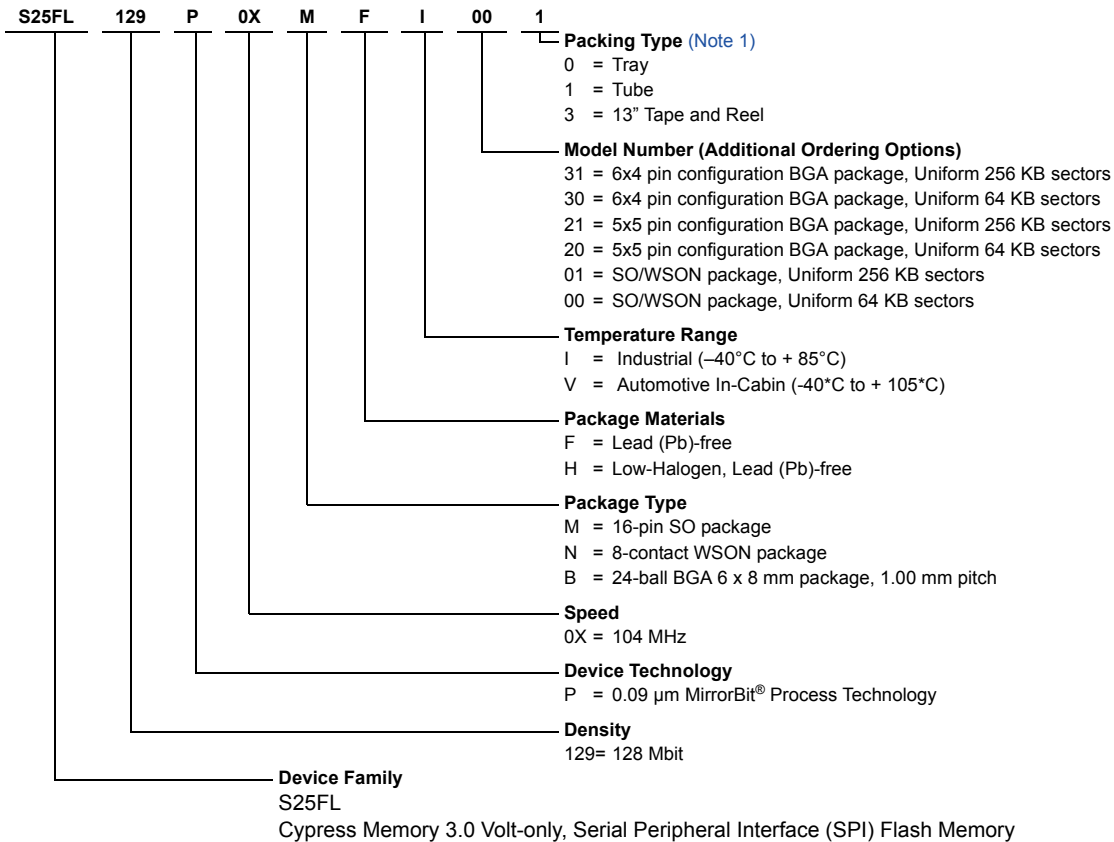

5.1 Valid Combinations

Table 5.1 lists the valid combinations configurations planned to be supported in volume for this device.

Table 5.1 S25FL129P Valid Combinations Table

S25FL129P Valid Combinations					Package Marking
Base Ordering Part Number	Speed Option	Package and Temperature	Model Number	Packing Type	
S25FL129P	0X	MFI, NFI	00	0, 1, 3	FL129P + (Temp) + F
		MFV, NFV	01		FL129P + (Temp) + FL
		BHI	20, 30	0, 3	FL129P + (Temp) + F
		BHV	21, 31		FL129P + (Temp) + FL

Note
1. Package Marking omits the leading "S25" and speed, package and model number.

6. SPI Modes

A microcontroller can use either of its two SPI modes to control Cypress SPI Flash memory devices:

- CPOL = 0, CPHA = 0 (Mode 0)
- CPOL = 1, CPHA = 1 (Mode 3)

Input data is latched in on the rising edge of SCK, and output data is available from the falling edge of SCK for both modes.

When the bus master is in standby mode, SCK is as shown in Figure 6.2 for each of the two modes:

- SCK remains at 0 for (CPOL = 0, CPHA = 0 Mode 0)
- SCK remains at 1 for (CPOL = 1, CPHA = 1 Mode 3)

Figure 6.1 Bus Master and Memory Devices on the SPI Bus

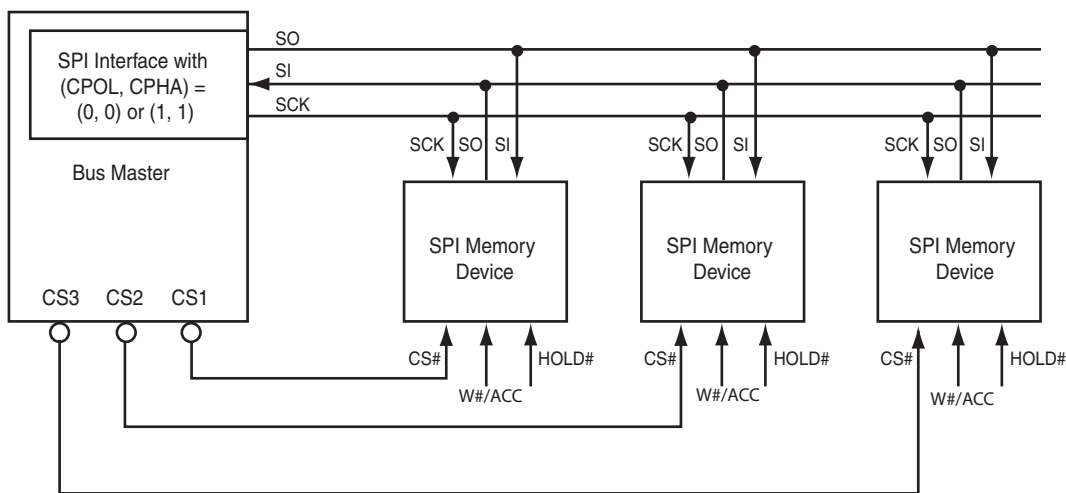

Note

The Write Protect/Accelerated Programming (W#/ACC) and Hold (HOLD#) signals should be driven high (logic level 1) or low (logic level 0) as appropriate.

Figure 6.2 SPI Modes Supported

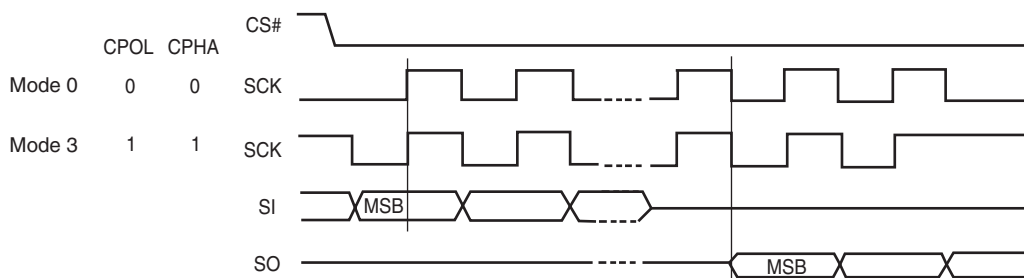

7. Device Operations

All Cypress SPI devices accept and output data in bytes (8 bits at a time). The SPI device is a slave device that supports an inactive clock while CS# is held low.

7.1 Byte or Page Programming

Programming data requires two commands: Write Enable (WREN), which is one byte, and a Page Program (PP) sequence, which consists of four bytes plus data. The Page Program sequence accepts from 1 byte up to 256 consecutive bytes of data (which is the size of one page) to be programmed in one operation. Programming means that bits can either be left at 0, or programmed from 1 to 0. Changing bits from 0 to 1 requires an erase operation.

7.2 Quad Page Programming

The Quad Page Program (QPP) instruction allows up to 256 bytes of data to be programmed using 4 pins as inputs at the same time, thus effectively quadrupling the data transfer rate, compared to the Page Program (PP) instruction. The Write Enable Latch (WEL) bit must be set to a 1 using the Write Enable (WREN) command prior to issuing the QPP command.

7.3 Dual and Quad I/O Mode

The S25FL129P device supports Dual and Quad I/O operation when using the Dual/Quad Output Read Mode and the Dual/Quad I/O High Performance Mode instructions. Using the Dual or Quad I/O instructions allows data to be transferred to or from the device at two to four times the rate of standard SPI devices. When operating in the Dual or Quad I/O High Performance Mode (BBh or EBh instructions), data can be read at fast speed using two or four data bits at a time, and the 3-byte address can be input two or four address bits at a time.

7.4 Sector Erase / Bulk Erase

The Sector Erase (SE) and Bulk Erase (BE) commands set all the bits in a sector or the entire memory array to 1. While bits can be individually programmed from 1 to 0, erasing bits from 0 to 1 must be done on a sector-wide (SE) or array-wide (BE) level. In addition to the 64-KB Sector Erase (SE), the S25FL129P device also offers 4-KB Parameter Sector Erase (P4E) and 8-KB Parameter Sector Erase (P8E) (only applicable for the uniform 64 KB sector device).

7.5 Monitoring Write Operations Using the Status Register

The host system can determine when a Write Register, program, or erase operation is complete by monitoring the Write in Progress (WIP) bit in the Status Register. The Read from Status Register command provides the state of the WIP bit. In addition, the S25FL129P device offers two additional bits in the Status Register (P_ERR, E_ERR) to indicate whether a Program or Erase operation was a success or failure.

7.6 Active Power and Standby Power Modes

The device is enabled and in the Active Power mode when Chip Select (CS#) is Low. When CS# is high, the device is disabled, but may still be in the Active Power mode until all program, erase, and Write Registers operations have completed. The device then goes into the Standby Power mode, and power consumption drops to I_{SB} . The Deep Power-Down (DP) command provides additional data protection against inadvertent signals. After writing the DP command, the device ignores any further program or erase commands, and reduces its power consumption to I_{DP} .

7.7 Status Register

The Status Register contains the status and control bits that can be read or set by specific commands (see [Table 9.1 on page 21](#)). These bits configure different protection configurations and supply information of operation of the device. (for details see [Table 9.8, S25FL129P Status Register on page 35](#)):

- **Write In Progress (WIP):** Indicates whether the device is performing a Write Registers, program or erase operation.
- **Write Enable Latch (WEL):** Indicates the status of the internal Write Enable Latch.
- **Block Protect (BP2, BP1, BP0):** Non-volatile bits that define memory area to be software-protected against program and erase commands.
- **Erase Error (E_ERR):** The Erase Error Bit is used as an Erase operation success and failure check.
- **Program Error (P_ERR):** The Program Error Bit is used as an program operation success and failure check.
- **Status Register Write Disable (SRWD):** Places the device in the Hardware Protected mode when this bit is set to 1 and the W#/ACC input is driven low. In this mode, the non-volatile bits of the Status Register (SRWD, BP2, BP1, BP0) become read-only bits.

7.8 Configuration Register

The Configuration Register contains the control bits that can be read or set by specific commands. These bits configure different configurations and security features of the device.

- The FREEZE bit locks the BP2-0 bits in Status Register and the TBPROT and TBPARAM bits in the Configuration Register. Note that once the FREEZE bit has been set to '1', then it cannot be cleared to '0' until a power-on-reset is executed. As long as the FREEZE bit is set to '0', then the other bits of the Configuration Register, including FREEZE bit, can be written to.
- The QUAD bit is non-volatile and sets the pin out of the device to Quad mode; that is, W#/ACC becomes IO2 and HOLD# becomes IO3. The instructions for Serial, Dual Output, and Dual I/O reads function as normal. The W#/ACC and HOLD# functionality does not work when the device is set in Quad mode.
- The TBPARAM bit defines the logical location of the 4 KB parameter sectors. The parameter sectors consist of thirty two 4 KB sectors. All sectors other than the parameter sectors are defined to be 64-KB uniform in size. When TBPARAM is set to a '1', the 4 KB parameter sectors starts at the top of the array. When TBPARAM is set to a '0', the 4 KB parameter sectors starts at the bottom of the array. Note that once this bit is set to a '1', it cannot be changed back to '0'. (This function is not applicable to the uniform 256 KB sector product.) The desired state of TBPARAM must be selected during the initial configuration of the device during system manufacture; before the first program or erase operation on the main Flash array. TBPARAM must not be programmed after programming or erasing is done in the main Flash array.
- The BPNV bit defines whether or not the BP2-0 bits in the Status Register are volatile or non-volatile. When BPNV is set to a '1', the BP2-0 bits in the Status Register are volatile and will be reset to binary 111 after power on reset. When BPNV is set to a '0', the BP2-0 bits in the Status Register are non-volatile. Note that once this bit is set to a '1', it cannot be changed back to '0'.
- The TBPROT bit defines the operation of the block protection bits BP2, BP1, and BP0 in the Status Register. When TBPROT is set to a '0', then the block protection is defined to start from the top of the array. When TBPROT is set to a '1', then the block protection is defined to start from the bottom of the array. Note that once this bit is set to a '1', it cannot be changed back to '0'. The desired state of TBPROT must be selected during the initial configuration of the device during system manufacture; before the first program or erase operation on the main Flash array. TBPROT must not be programmed after programming or erasing is done in the main Flash array.

Note: It is suggested that the Block Protection and Parameter sectors not be set to the same area of the array; otherwise, the user cannot utilize the Parameter sectors if they are protected. The following matrix shows the recommended settings.

TBPARM	TBPROT	Array Overview
0	0	Parameter Sectors - Bottom BP Protection - Top (default)
0	1	Not recommended (Parameters and BP Protection are both Bottom)
1	0	Not recommended (parameters and BP Protection are both Top)
1	1	Parameter Sectors - Top of Array (high address) BP Protection - Bottom of Array (low address)

Table 7.1 Configuration Register Table (Uniform 64 KB sector)

Bit	Bit Name	Bit Function	Description
7	NA	-	Not Used
6	NA	-	Not Used
5	TBPROT	Configures start of block protection	1 = Bottom Array (low address) 0 = Top Array (high address) (Default)
4	NA	-	Do Not Use
3	BPNV	Configures BP2-0 bits in the Status Register	1 = Volatile 0 = Non-volatile (Default)
2	TBPARM	Configures Parameter sector location	1 = Top Array (high address) 0 = Bottom Array (low address) (Default)
1	QUAD	Puts the device into Quad I/O mode	1 = Quad I/O 0 = Dual or Serial I/O (Default)
0	FREEZE	Locks BP2-0 bits in the Status Register	1 = Enabled 0 = Disabled (Default)

Note
(Default) indicates the value of each Configuration Register bit set upon initial factory shipment.

Table 7.2 Configuration Register Table (Uniform 256 KB sector)

Bit	Bit Name	Bit Function	Description
7	N/A	-	Not Used
6	N/A	-	Not Used
5	TBPROT	Configures start of block protection	1 = Bottom Array (low address) 0 = Top Array (high address) (Default)
4	N/A	-	Do Not Use
3	BPNV	Configures BP2-0 bits in the Status Register	1 = Volatile 0 = Non-volatile (Default)
2	N/A	-	Do not Use
1	QUAD	Puts the device into Quad I/O mode	1 = Quad I/O 0 = Dual or Serial I/O (Default)
0	FREEZE	Locks BP2-0 bits in the Status Register	1 = Enabled 0 = Disabled (Default)

Note
1. (Default) indicates the value of each Configuration Register bit set upon initial factory shipment.

7.9 Data Protection Modes

Cypress SPI Flash memory devices provide the following data protection methods:

- **The Write Enable (WREN) command:** Must be written prior to any command that modifies data. The WREN command sets the Write Enable Latch (WEL) bit. The WEL bit resets (disables writes) on power-up or after the device completes the following commands:
 - Page Program (PP)
 - Sector Erase (SE)
 - Bulk Erase (BE)
 - Write Disable (WRDI)
 - Write Register (WRR)
 - Parameter 4 KB Sector Erase (P4E)
 - Parameter 8 KB Sector Erase (P8E)
 - Quad Page Programming (QPP)
 - OTP Byte Programming (OTPP)
- **Software Protected Mode (SPM):** The Block Protect BP2, BP1, BP0 bits define the section of the memory array that can be read but not programmed or erased. [Table 7.3](#) and [Table 7.4](#) shows the sizes and address ranges of protected areas that are defined by Status Register bits BP2:BP0.
- **Hardware Protected Mode (HPM):** The Write Protect (W#/ACC) input and the Status Register Write Disable (SRWD) bit together provide write protection.
- **Clock Pulse Count:** The device verifies that all program, erase, and Write Register commands consist of a clock pulse count that is a multiple of eight before executing them.

Table 7.3 TBPROT = 0 (Starts Protection from TOP of Array)

Status Register Block			Memory Array						Protected Portion of Total Memory Area
BP2	BP1	BP0	Protected Address Range	Protected Sectors		Unprotected Address Range	Unprotected Sectors		
				Uniform 64 KB	Uniform 256 KB		Uniform 64 KB	Uniform 256 KB	
0	0	0	None	0	0	000000h - FFFFFFFh	SA255:SA0	SA63:SA0	0
0	0	1	FC0000h - FFFFFFFh	(4) SA255:SA252	(1) SA63	000000h - FBFFFFFFh	SA251:SA0	SA62:SA0	1/64
0	1	0	F80000h - FFFFFFFh	(8) SA255:SA248	(2)SA63:SA62	000000h - F7FFFFFFh	SA247:SA0	SA61:SA0	1/32
0	1	1	F00000h - FFFFFFFh	(16) SA255:SA240	(4)SA63:SA60	000000h - EFFFFFFh	SA239:SA0	SA59:SA0	1/16
1	0	0	E00000h - FFFFFFFh	(32) SA255:SA224	(8)SA63:SA56	000000h - DFFFFFFh	SA223:SA0	SA55:SA0	1/8
1	0	1	C00000h - FFFFFFFh	(64)SA255:SA192	(16)SA63:SA48	000000h - BFFFFFFh	SA191:SA0	SA47:SA0	1/4
1	1	0	800000h - FFFFFFFh	(128)SA255:SA128	(32)SA63:SA32	000000h - 7FFFFFFh	SA127:SA0	SA31:SA0	1/2
1	1	1	000000h - FFFFFFFh	(256)SA255:SA0	(64)SA63:SA0	None	None	None	All

Table 7.4 TBPROT = 1 (Starts Protection from BOTTOM of Array)

Status Register Block			Memory Array						Protected Portion of Total Memory Area
BP2	BP1	BP0	Protected Address Range	Protected Sectors		Unprotected Address Range	Unprotected Sectors		
				Uniform 64 KB	Uniform 256 KB		Uniform 64 KB	Uniform 256 KB	
0	0	0	None	0	0	000000h - FFFFFFFh	SA0:SA255	SA0:SA63	0
0	0	1	000000h - 03FFFFFFh	(4) SA0:SA3	(1) SA0	040000h - FFFFFFFh	SA4:SA255	SA1:SA63	1/64
0	1	0	000000h - 07FFFFFFh	(8) SA0:SA7	(2)SA0:SA1	080000h - FFFFFFFh	SA8:SA255	SA2:SA63	1/32
0	1	1	000000h - 0FFFFFFh	(16)SA0:SA15	(4)SA0:SA3	100000h - FFFFFFFh	SA16:SA255	SA4:SA63	1/16
1	0	0	000000h - 1FFFFFFh	(32)SA0:SA31	(8)SA0:SA7	200000h - FFFFFFFh	SA32:SA255	SA8:SA63	1/8

Table 7.4 TBPROT = 1 (Starts Protection from BOTTOM of Array)

Status Register Block			Memory Array						Protected Portion of Total Memory Area
BP2	BP1	BP0	Protected Address Range	Protected Sectors		Unprotected Address Range	Unprotected Sectors		
				Uniform 64 KB	Uniform 256 KB		Uniform 64 KB	Uniform 256 KB	
1	0	1	000000h - 3FFFFFFh	(64)SA0:SA63	(16)SA0:SA15	400000h - FFFFFFFh	SA64:SA255	SA16:SA63	1/4
1	1	0	000000h - 7FFFFFFh	(128)SA0:SA127	(32)SA0:SA31	800000h - FFFFFFFh	SA128:255	SA32:SA63	1/2
1	1	1	000000h - FFFFFFFh	(256)SA0:SA255	(64)SA0:SA63	None	None	None	All

7.10 Hold Mode (HOLD#)

The Hold input (HOLD#) stops any serial communication with the device, but does not terminate any Write Registers, program or erase operation that is currently in progress.

The Hold mode starts on the falling edge of HOLD# if SCK is also low (see Figure 7.1, standard use). If the falling edge of HOLD# does not occur while SCK is low, the Hold mode begins after the next falling edge of SCK (non-standard use).

The Hold mode ends on the rising edge of HOLD# signal (standard use) if SCK is also low. If the rising edge of HOLD# does not occur while SCK is low, the Hold mode ends on the next falling edge of CLK (non-standard use) See Figure 7.1.

The SO output is high impedance, and the SI and SCK inputs are ignored (don't care) for the duration of the Hold mode.

CS# must remain low for the entire duration of the Hold mode to ensure that the device internal logic remains unchanged. If CS# goes high while the device is in the Hold mode, the internal logic is reset. To prevent the device from reverting to the Hold mode when device communication is resumed, HOLD# must be held high, followed by driving CS# low.

Note: The HOLD Mode feature is disabled during Quad I/O Mode.

Figure 7.1 Hold Mode Operation

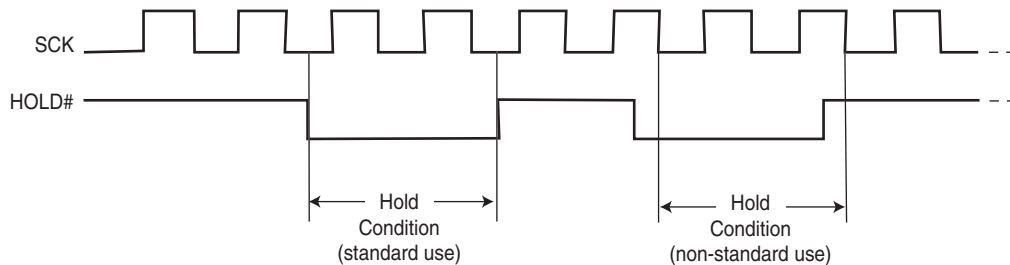

7.11 Accelerated Programming Operation

The device offers accelerated program operations through the ACC function. This function is primarily intended to allow faster manufacturing throughput at the factory. If the system asserts V_{HH} on this pin, the device uses the higher voltage on the pin to reduce the time required for program operations. Removing V_{HH} from the W#/ACC pin returns the device to normal operation. Note that the W#/ACC pin must not be at V_{HH} for operations other than accelerated programming, or device damage may result. In addition, the W#/ACC pin must not be left floating or unconnected; inconsistent behavior of the device may result.

Note: The ACC function is disabled during Quad I/O Mode.

8. Sector Address Table

The Sector Address tables show the size of the memory array, sectors, and pages. The device uses pages to cache the program data before the data is programmed into the memory array. Each page or byte can be individually programmed (bits are changed from 1 to 0). The data is erased (bits are changed from 0 to 1) on a sub-sector, sector- or device-wide basis using the P4E/P8E (applicable only for the uniform 64 KB sector device), SE or BE commands. [Table 8.1](#) to [Table 8.3](#) show the starting and ending address for each sector. The complete set of sectors comprises the memory array of the Flash device.

Table 8.1 S25FL129P Sector Address Table (Uniform 256 KB sector)

Sector	Address Range		Sector	Address Range	
	Start Address	End Address		Start Address	End Address
63	FC0000h	FFFFFFh	31	7C0000h	7FFFFFFh
62	F80000h	FBFFFFh	30	780000h	7BFFFFh
61	F40000h	F7FFFFh	29	740000h	77FFFFh
60	F00000h	F3FFFFh	28	700000h	73FFFFh
59	EC0000h	EFFFFFFh	27	6C0000h	6FFFFFFh
58	E80000h	EBFFFFh	26	680000h	6BFFFFh
57	E40000h	E7FFFFh	25	640000h	67FFFFh
56	E00000h	E3FFFFh	24	600000h	63FFFFh
55	DC0000h	DFFFFFFh	23	5C0000h	5FFFFFFh
54	D80000h	DBFFFFh	22	580000h	5BFFFFh
53	D40000h	D7FFFFh	21	540000h	57FFFFh
52	D00000h	D3FFFFh	20	500000h	53FFFFh
51	CC0000h	CFFFFFFh	19	4C0000h	4FFFFFFh
50	C80000h	CBFFFFh	18	480000h	4BFFFFh
49	C40000h	C7FFFFh	17	440000h	47FFFFh
48	C00000h	C3FFFFh	16	400000h	43FFFFh
47	BC0000h	BFFFFFFh	15	3C0000h	3FFFFFFh
46	B80000h	BBFFFFh	14	380000h	3BFFFFh
45	B40000h	B7FFFFh	13	340000h	37FFFFh
44	B00000h	B3FFFFh	12	300000h	33FFFFh
43	AC0000h	AFFFFFFh	11	2C0000h	2FFFFFFh
42	A80000h	ABFFFFh	10	280000h	2BFFFFh
41	A40000h	A7FFFFh	9	240000h	27FFFFh
40	A00000h	A3FFFFh	8	200000h	23FFFFh
39	9C0000h	9FFFFFFh	7	1C0000h	1FFFFFFh
38	980000h	9BFFFFh	6	180000h	1BFFFFh
37	940000h	97FFFFh	5	140000h	17FFFFh
36	900000h	93FFFFh	4	100000h	13FFFFh
35	8C0000h	8FFFFFFh	3	0C0000h	0FFFFFFh
34	880000h	8BFFFFh	2	080000h	0BFFFFh
33	840000h	87FFFFh	1	040000h	07FFFFh
32	800000h	83FFFFh	0	000000h	03FFFFh

Table 8.2 S25FL129P Sector Address Table (Uniform 64 KB sector, TBPARM=0) (Sheet 1 of 2)

Sector	Address Range		Sector	Address Range		Sector	Address Range	
	Start Address	End Address		Start Address	End Address		Start Address	End Address
SA108	6C0000h	6CFFFFh	SA61	3D0000h	3DFFFFh	SA14	0E0000h	0EFFFFh
SA107	6B0000h	6BFFFFh	SA60	3C0000h	3CFFFFh	SA13	0D0000h	0DFFFFh
SA106	6A0000h	6AFFFFh	SA59	3B0000h	3BFFFFh	SA12	0C0000h	0CFFFFh
SA105	690000h	69FFFFh	SA58	3A0000h	3AFFFFh	SA11	0B0000h	0BFFFFh
SA104	680000h	68FFFFh	SA57	390000h	39FFFFh	SA10	0A0000h	0AFFFFh
SA103	670000h	67FFFFh	SA56	380000h	38FFFFh	SA9	090000h	09FFFFh
SA102	660000h	66FFFFh	SA55	370000h	37FFFFh	SA8	080000h	08FFFFh
SA101	650000h	65FFFFh	SA54	360000h	36FFFFh	SA7	070000h	07FFFFh
SA100	640000h	64FFFFh	SA53	350000h	35FFFFh	SA6	060000h	06FFFFh
SA99	630000h	63FFFFh	SA52	340000h	34FFFFh	SA5	050000h	05FFFFh
SA98	620000h	62FFFFh	SA51	330000h	33FFFFh	SA4	040000h	04FFFFh
SA97	610000h	61FFFFh	SA50	320000h	32FFFFh	SA3	030000h	03FFFFh
SA96	600000h	60FFFFh	SA49	310000h	31FFFFh	SA2	020000h	02FFFFh
SA95	5F0000h	5FFFFFh	SA48	300000h	30FFFFh	SA1	010000h	01FFFFh
SA94	5E0000h	5EFFFFh	SA47	2F0000h	2FFFFFh	SA0	000000h	00FFFFh
SA93	5D0000h	5DFFFFh	SA46	2E0000h	2EFFFFh	SS31	01F000h	01FFFFh
SA92	5C0000h	5CFFFFh	SA45	2D0000h	2DFFFFh	SS30	01E000h	01EFFFh
SA91	5B0000h	5BFFFFh	SA44	2C0000h	2CFFFFh	SS29	01D000h	01DFFFh
SA90	5A0000h	5AFFFFh	SA43	2B0000h	2BFFFFh	SS28	01C000h	01CFFFh
SA89	590000h	59FFFFh	SA42	2A0000h	2AFFFFh	SS27	01B000h	01BFFFh
SA88	580000h	58FFFFh	SA41	290000h	29FFFFh	SS26	01A000h	01AFFFh
SA87	570000h	57FFFFh	SA40	280000h	28FFFFh	SS25	019000h	019FFFh
SA86	560000h	56FFFFh	SA39	270000h	27FFFFh	SS24	018000h	018FFFh
SA85	550000h	55FFFFh	SA38	260000h	26FFFFh	SS23	017000h	017FFFh
SA84	540000h	54FFFFh	SA37	250000h	25FFFFh	SS22	016000h	016FFFh
SA83	530000h	53FFFFh	SA36	240000h	24FFFFh	SS21	015000h	015FFFh
SA82	520000h	52FFFFh	SA35	230000h	23FFFFh	SS20	014000h	014FFFh
SA81	510000h	51FFFFh	SA34	220000h	22FFFFh	SS19	013000h	013FFFh
SA80	500000h	50FFFFh	SA33	210000h	21FFFFh	SS18	012000h	012FFFh
SA79	4F0000h	4FFFFFh	SA32	200000h	20FFFFh	SS17	011000h	011FFFh
SA78	4E0000h	4EFFFFh	SA31	1F0000h	1FFFFFh	SS16	010000h	010FFFh
SA77	4D0000h	4DFFFFh	SA30	1E0000h	1EFFFFh	SS15	00F000h	00FFFFh
SA76	4C0000h	4CFFFFh	SA29	1D0000h	1DFFFFh	SS14	00E000h	00EFFFh
SA75	4B0000h	4BFFFFh	SA28	1C0000h	1CFFFFh	SS13	00D000h	00DFFFh
SA74	4A0000h	4AFFFFh	SA27	1B0000h	1BFFFFh	SS12	00C000h	00CFFFh
SA73	490000h	49FFFFh	SA26	1A0000h	1AFFFFh	SS11	00B000h	00BFFFh
SA72	480000h	48FFFFh	SA25	190000h	19FFFFh	SS10	00A000h	00AFFFh
SA71	470000h	47FFFFh	SA24	180000h	18FFFFh	SS9	009000h	009FFFh
SA70	460000h	46FFFFh	SA23	170000h	17FFFFh	SS8	008000h	008FFFh
SA69	450000h	45FFFFh	SA22	160000h	16FFFFh	SS7	007000h	007FFFh
SA68	440000h	44FFFFh	SA21	150000h	15FFFFh	SS6	006000h	006FFFh
SA67	430000h	43FFFFh	SA20	140000h	14FFFFh	SS5	005000h	005FFFh
SA66	420000h	42FFFFh	SA19	130000h	13FFFFh	SS4	004000h	004FFFh
SA65	410000h	41FFFFh	SA18	120000h	12FFFFh	SS3	003000h	003FFFh
SA64	400000h	40FFFFh	SA17	110000h	11FFFFh	SS2	002000h	002FFFh
SA63	3F0000h	3FFFFFh	SA16	100000h	10FFFFh	SS1	001000h	001FFFh
SA62	3E0000h	3EFFFFh	SA15	0F0000h	0FFFFFh	SS0	000000h	000FFFh

Table 8.2 S25FL129P Sector Address Table (Uniform 64 KB sector, TBPARM=0) (Sheet 2 of 2)

Sector	Address Range		Sector	Address Range		Sector	Address Range	
	Start Address	End Address		Start Address	End Address		Start Address	End Address
SA255	FF0000h	FFFFFFh	SA206	CE0000h	CEFFFFh	SA157	9D0000h	9DFFFFh
SA254	FE0000h	FEFFFFh	SA205	CD0000h	CDFFFFh	SA156	9C0000h	9CFFFFh
SA253	FD0000h	FDFFFFh	SA204	CC0000h	CCFFFFh	SA155	9B0000h	9BFFFFh
SA252	FC0000h	FCFFFFh	SA203	CB0000h	CBFFFFh	SA154	9A0000h	9AFFFFh
SA251	FB0000h	FBFFFFh	SA202	CA0000h	CAFFFFh	SA153	990000h	99FFFFh
SA250	FA0000h	FAFFFFh	SA201	C90000h	C9FFFFh	SA152	980000h	98FFFFh
SA249	F90000h	F9FFFFh	SA200	C80000h	C8FFFFh	SA151	970000h	97FFFFh
SA248	F80000h	F8FFFFh	SA199	C70000h	C7FFFFh	SA150	960000h	96FFFFh
SA247	F70000h	F7FFFFh	SA198	C60000h	C6FFFFh	SA149	950000h	95FFFFh
SA246	F60000h	F6FFFFh	SA197	C50000h	C5FFFFh	SA148	940000h	94FFFFh
SA245	F50000h	F5FFFFh	SA196	C40000h	C4FFFFh	SA147	930000h	93FFFFh
SA244	F40000h	F4FFFFh	SA195	C30000h	C3FFFFh	SA146	920000h	92FFFFh
SA243	F30000h	F3FFFFh	SA194	C20000h	C2FFFFh	SA145	910000h	91FFFFh
SA242	F20000h	F2FFFFh	SA193	C10000h	C1FFFFh	SA144	900000h	90FFFFh
SA241	F10000h	F1FFFFh	SA192	C00000h	C0FFFFh	SA143	8F0000h	8FFFFFh
SA240	F00000h	F0FFFFh	SA191	BF0000h	BFFFFFh	SA142	8E0000h	8EFFFFh
SA239	EF0000h	EFFFFFh	SA190	BE0000h	BEFFFFh	SA141	8D0000h	8DFFFFh
SA238	EE0000h	EEFFFFh	SA189	BD0000h	BDFFFFh	SA140	8C0000h	8CFFFFh
SA237	ED0000h	EDFFFFh	SA188	BC0000h	BCFFFFh	SA139	8B0000h	8BFFFFh
SA236	EC0000h	ECFFFFh	SA187	BB0000h	BBFFFFh	SA138	8A0000h	8AFFFFh
SA235	EB0000h	EBFFFFh	SA186	BA0000h	BAFFFFh	SA137	890000h	89FFFFh
SA234	EA0000h	EAFFFFh	SA185	B90000h	B9FFFFh	SA136	880000h	88FFFFh
SA233	E90000h	E9FFFFh	SA184	B80000h	B8FFFFh	SA135	870000h	87FFFFh
SA232	E80000h	E8FFFFh	SA183	B70000h	B7FFFFh	SA134	860000h	86FFFFh
SA231	E70000h	E7FFFFh	SA182	B60000h	B6FFFFh	SA133	850000h	85FFFFh
SA230	E60000h	E6FFFFh	SA181	B50000h	B5FFFFh	SA132	840000h	84FFFFh
SA229	E50000h	E5FFFFh	SA180	B40000h	B4FFFFh	SA131	830000h	83FFFFh
SA228	E40000h	E4FFFFh	SA179	B30000h	B3FFFFh	SA130	820000h	82FFFFh
SA227	E30000h	E3FFFFh	SA178	B20000h	B2FFFFh	SA129	810000h	81FFFFh
SA226	E20000h	E2FFFFh	SA177	B10000h	B1FFFFh	SA128	800000h	80FFFFh
SA225	E10000h	E1FFFFh	SA176	B00000h	B0FFFFh	SA127	7F0000h	7FFFFFh
SA224	E00000h	E0FFFFh	SA175	AF0000h	AFFFFFh	SA126	7E0000h	7EFFFFh
SA223	DF0000h	DFFFFFh	SA174	AE0000h	AEFFFFh	SA125	7D0000h	7DFFFFh
SA222	DE0000h	DEFFFFh	SA173	AD0000h	ADFFFFh	SA124	7C0000h	7CFFFFh
SA221	DD0000h	DDFFFFh	SA172	AC0000h	ACFFFFh	SA123	7B0000h	7BFFFFh
SA220	DC0000h	DCFFFFh	SA171	AB0000h	ABFFFFh	SA122	7A0000h	7AFFFFh
SA219	DB0000h	DBFFFFh	SA170	AA0000h	AAFFFFh	SA121	790000h	79FFFFh
SA218	DA0000h	DAFFFFh	SA169	A90000h	A9FFFFh	SA120	780000h	78FFFFh
SA217	D90000h	D9FFFFh	SA168	A80000h	A8FFFFh	SA119	770000h	77FFFFh
SA216	D80000h	D8FFFFh	SA167	A70000h	A7FFFFh	SA118	760000h	76FFFFh
SA215	D70000h	D7FFFFh	SA166	A60000h	A6FFFFh	SA117	750000h	75FFFFh
SA214	D60000h	D6FFFFh	SA165	A50000h	A5FFFFh	SA116	740000h	74FFFFh
SA213	D50000h	D5FFFFh	SA164	A40000h	A4FFFFh	SA115	730000h	73FFFFh
SA212	D40000h	D4FFFFh	SA163	A30000h	A3FFFFh	SA114	720000h	72FFFFh
SA211	D30000h	D3FFFFh	SA162	A20000h	A2FFFFh	SA113	710000h	71FFFFh
SA210	D20000h	D2FFFFh	SA161	A10000h	A1FFFFh	SA112	700000h	70FFFFh
SA209	D10000h	D1FFFFh	SA160	A00000h	A0FFFFh	SA111	6F0000h	6FFFFFh
SA208	D00000h	D0FFFFh	SA159	9F0000h	9FFFFFh	SA110	6E0000h	6EFFFFh
SA207	CF0000h	CFFFFFh	SA158	9E0000h	9EFFFFh	SA109	6D0000h	6DFFFFh

Note

Sector SA0 is split up into sub-sectors SS0 - SS15 (dark gray shading)

Sector SA1 is split up into sub-sectors SS16 - SS31 (light gray shading)

Table 8.3 S25FL129P Sector Address Table (Uniform 64 KB sector, TBPARM=1) (Sheet 1 of 2)

Sector	Address Range		Sector	Address Range		Sector	Address Range	
	Start Address	End Address		Start Address	End Address		Start Address	End Address
SS31	FFF000h	FFFFFFh	SA239	EF0000h	EFFFFFFh	SA191	BF0000h	BFFFFFFh
SS30	FFE000h	FEFFFFh	SA238	EE0000h	EFFFFFFh	SA190	BE0000h	BEFFFFh
SS29	FFD000h	FFDFFFh	SA237	ED0000h	EDFFFFh	SA189	BD0000h	BDFFFFh
SS28	FFC000h	FFCFFFh	SA236	EC0000h	ECFFFFh	SA188	BC0000h	BCFFFFh
SS27	FFB000h	FFBFFFh	SA235	EB0000h	EBFFFFh	SA187	BB0000h	BBFFFFh
SS26	FFA000h	FFAFFFh	SA234	EA0000h	EAFFFFh	SA186	BA0000h	BAFFFFh
SS25	FF9000h	FF9FFFh	SA233	E90000h	E9FFFFh	SA185	B90000h	B9FFFFh
SS24	FF8000h	FF8FFFh	SA232	E80000h	E8FFFFh	SA184	B80000h	B8FFFFh
SS23	FF7000h	FF7FFFh	SA231	E70000h	E7FFFFh	SA183	B70000h	B7FFFFh
SS22	FF6000h	FF6FFFh	SA230	E60000h	E6FFFFh	SA182	B60000h	B6FFFFh
SS21	FF5000h	FF5FFFh	SA229	E50000h	E5FFFFh	SA181	B50000h	B5FFFFh
SS20	FF4000h	FF4FFFh	SA228	E40000h	E4FFFFh	SA180	B40000h	B4FFFFh
SS19	FF3000h	FF3FFFh	SA227	E30000h	E3FFFFh	SA179	B30000h	B3FFFFh
SS18	FF2000h	FF2FFFh	SA226	E20000h	E2FFFFh	SA178	B20000h	B2FFFFh
SS17	FF1000h	FF1FFFh	SA225	E10000h	E1FFFFh	SA177	B10000h	B1FFFFh
SS16	FF0000h	FF0FFFh	SA224	E00000h	E0FFFFh	SA176	B00000h	B0FFFFh
SS15	FEF000h	FEFFFFh	SA223	DF0000h	DFFFFFFh	SA175	AF0000h	AFFFFFFh
SS14	FEE000h	FEEFFFh	SA222	DE0000h	DEFFFFh	SA174	AE0000h	AFFFFFFh
SS13	FED000h	FEDFFFh	SA221	DD0000h	DDFFFFh	SA173	AD0000h	ADFFFFh
SS12	FEC000h	FECFFFh	SA220	DC0000h	DCFFFFh	SA172	AC0000h	ACFFFFh
SS11	FEB000h	FEBFFFh	SA219	DB0000h	DBFFFFh	SA171	AB0000h	ABFFFFh
SS10	FEA000h	FEAFFFh	SA218	DA0000h	DAFFFFh	SA170	AA0000h	AAFFFFh
SS9	FE9000h	FE9FFFh	SA217	D90000h	D9FFFFh	SA169	A90000h	A9FFFFh
SS8	FE8000h	FE8FFFh	SA216	D80000h	D8FFFFh	SA168	A80000h	A8FFFFh
SS7	FE7000h	FE7FFFh	SA215	D70000h	D7FFFFh	SA167	A70000h	A7FFFFh
SS6	FE6000h	FE6FFFh	SA214	D60000h	D6FFFFh	SA166	A60000h	A6FFFFh
SS5	FE5000h	FE5FFFh	SA213	D50000h	D5FFFFh	SA165	A50000h	A5FFFFh
SS4	FE4000h	FE4FFFh	SA212	D40000h	D4FFFFh	SA164	A40000h	A4FFFFh
SS3	FE3000h	FE3FFFh	SA211	D30000h	D3FFFFh	SA163	A30000h	A3FFFFh
SS2	FE2000h	FE2FFFh	SA210	D20000h	D2FFFFh	SA162	A20000h	A2FFFFh
SS1	FE1000h	FE1FFFh	SA209	D10000h	D1FFFFh	SA161	A10000h	A1FFFFh
SS0	FE0000h	FE0FFFh	SA208	D00000h	D0FFFFh	SA160	A00000h	A0FFFFh
SA255	FF0000h	FFFFFFh	SA207	CF0000h	CFFFFFFh	SA159	9F0000h	9FFFFFFh
SA254	FE0000h	FEFFFFh	SA206	CE0000h	CEFFFFh	SA158	9E0000h	9EFFFFh
SA253	FD0000h	FDFFFFh	SA205	CD0000h	CDFFFFh	SA157	9D0000h	9DFFFFh
SA252	FC0000h	FCFFFFh	SA204	CC0000h	CCFFFFh	SA156	9C0000h	9CFFFFh
SA251	FB0000h	FBFFFFh	SA203	CB0000h	CBFFFFh	SA155	9B0000h	9BFFFFh
SA250	FA0000h	FAFFFFh	SA202	CA0000h	CAFFFFh	SA154	9A0000h	9AFFFFh
SA249	F90000h	F9FFFFh	SA201	C90000h	C9FFFFh	SA153	990000h	99FFFFh
SA248	F80000h	F8FFFFh	SA200	C80000h	C8FFFFh	SA152	980000h	98FFFFh
SA247	F70000h	F7FFFFh	SA199	C70000h	C7FFFFh	SA151	970000h	97FFFFh
SA246	F60000h	F6FFFFh	SA198	C60000h	C6FFFFh	SA150	960000h	96FFFFh
SA245	F50000h	F5FFFFh	SA197	C50000h	C5FFFFh	SA149	950000h	95FFFFh
SA244	F40000h	F4FFFFh	SA196	C40000h	C4FFFFh	SA148	940000h	94FFFFh
SA243	F30000h	F3FFFFh	SA195	C30000h	C3FFFFh	SA147	930000h	93FFFFh
SA242	F20000h	F2FFFFh	SA194	C20000h	C2FFFFh	SA146	920000h	92FFFFh
SA241	F10000h	F1FFFFh	SA193	C10000h	C1FFFFh	SA145	910000h	91FFFFh
SA240	F00000h	F0FFFFh	SA192	C00000h	C0FFFFh	SA144	900000h	90FFFFh

Table 8.3 S25FL129P Sector Address Table (Uniform 64 KB sector, TBPARAM=1) (Sheet 2 of 2)

Sector	Address Range		Sector	Address Range		Sector	Address Range	
	Start Address	End Address		Start Address	End Address		Start Address	End Address
SA143	8F0000h	8FFFFFFh	SA95	5F0000h	5FFFFFFh	SA47	2F0000h	2FFFFFFh
SA142	8E0000h	8EFFFFh	SA94	5E0000h	5EFFFFh	SA46	2E0000h	2EFFFFh
SA141	8D0000h	8DFFFFh	SA93	5D0000h	5DFFFFh	SA45	2D0000h	2DFFFFh
SA140	8C0000h	8CFFFFh	SA92	5C0000h	5CFFFFh	SA44	2C0000h	2CFFFFh
SA139	8B0000h	8BFFFFh	SA91	5B0000h	5BFFFFh	SA43	2B0000h	2BFFFFh
SA138	8A0000h	8AFFFFh	SA90	5A0000h	5AFFFFh	SA42	2A0000h	2AFFFFh
SA137	890000h	89FFFFh	SA89	590000h	59FFFFh	SA41	290000h	29FFFFh
SA136	880000h	88FFFFh	SA88	580000h	58FFFFh	SA40	280000h	28FFFFh
SA135	870000h	87FFFFh	SA87	570000h	57FFFFh	SA39	270000h	27FFFFh
SA134	860000h	86FFFFh	SA86	560000h	56FFFFh	SA38	260000h	26FFFFh
SA133	850000h	85FFFFh	SA85	550000h	55FFFFh	SA37	250000h	25FFFFh
SA132	840000h	84FFFFh	SA84	540000h	54FFFFh	SA36	240000h	24FFFFh
SA131	830000h	83FFFFh	SA83	530000h	53FFFFh	SA35	230000h	23FFFFh
SA130	820000h	82FFFFh	SA82	520000h	52FFFFh	SA34	220000h	22FFFFh
SA129	810000h	81FFFFh	SA81	510000h	51FFFFh	SA33	210000h	21FFFFh
SA128	800000h	80FFFFh	SA80	500000h	50FFFFh	SA32	200000h	20FFFFh
SA127	7F0000h	7FFFFFFh	SA79	4F0000h	4FFFFFFh	SA31	1F0000h	1FFFFFFh
SA126	7E0000h	7EFFFFh	SA78	4E0000h	4EFFFFh	SA30	1E0000h	1EFFFFh
SA125	7D0000h	7DFFFFh	SA77	4D0000h	4DFFFFh	SA29	1D0000h	1DFFFFh
SA124	7C0000h	7CFFFFh	SA76	4C0000h	4CFFFFh	SA28	1C0000h	1CFFFFh
SA123	7B0000h	7BFFFFh	SA75	4B0000h	4BFFFFh	SA27	1B0000h	1BFFFFh
SA122	7A0000h	7AFFFFh	SA74	4A0000h	4AFFFFh	SA26	1A0000h	1AFFFFh
SA121	790000h	79FFFFh	SA73	490000h	49FFFFh	SA25	190000h	19FFFFh
SA120	780000h	78FFFFh	SA72	480000h	48FFFFh	SA24	180000h	18FFFFh
SA119	770000h	77FFFFh	SA71	470000h	47FFFFh	SA23	170000h	17FFFFh
SA118	760000h	76FFFFh	SA70	460000h	46FFFFh	SA22	160000h	16FFFFh
SA117	750000h	75FFFFh	SA69	450000h	45FFFFh	SA21	150000h	15FFFFh
SA116	740000h	74FFFFh	SA68	440000h	44FFFFh	SA20	140000h	14FFFFh
SA115	730000h	73FFFFh	SA67	430000h	43FFFFh	SA19	130000h	13FFFFh
SA114	720000h	72FFFFh	SA66	420000h	42FFFFh	SA18	120000h	12FFFFh
SA113	710000h	71FFFFh	SA65	410000h	41FFFFh	SA17	110000h	11FFFFh
SA112	700000h	70FFFFh	SA64	400000h	40FFFFh	SA16	100000h	10FFFFh
SA111	6F0000h	6FFFFFFh	SA63	3F0000h	3FFFFFFh	SA15	0F0000h	0FFFFFFh
SA110	6E0000h	6EFFFFh	SA62	3E0000h	3EFFFFh	SA14	0E0000h	0EFFFFh
SA109	6D0000h	6DFFFFh	SA61	3D0000h	3DFFFFh	SA13	0D0000h	0DFFFFh
SA108	6C0000h	6CFFFFh	SA60	3C0000h	3CFFFFh	SA12	0C0000h	0CFFFFh
SA107	6B0000h	6BFFFFh	SA59	3B0000h	3BFFFFh	SA11	0B0000h	0BFFFFh
SA106	6A0000h	6AFFFFh	SA58	3A0000h	3AFFFFh	SA10	0A0000h	0AFFFFh
SA105	690000h	69FFFFh	SA57	390000h	39FFFFh	SA9	090000h	09FFFFh
SA104	680000h	68FFFFh	SA56	380000h	38FFFFh	SA8	080000h	08FFFFh
SA103	670000h	67FFFFh	SA55	370000h	37FFFFh	SA7	070000h	07FFFFh
SA102	660000h	66FFFFh	SA54	360000h	36FFFFh	SA6	060000h	06FFFFh
SA101	650000h	65FFFFh	SA53	350000h	35FFFFh	SA5	050000h	05FFFFh
SA100	640000h	64FFFFh	SA52	340000h	34FFFFh	SA4	040000h	04FFFFh
SA99	630000h	63FFFFh	SA51	330000h	33FFFFh	SA3	030000h	03FFFFh
SA98	620000h	62FFFFh	SA50	320000h	32FFFFh	SA2	020000h	02FFFFh
SA97	610000h	61FFFFh	SA49	310000h	31FFFFh	SA1	010000h	01FFFFh
SA96	600000h	60FFFFh	SA48	300000h	30FFFFh	SA0	000000h	00FFFFh

Note

Sector SA254 is split up into sub-sectors SS0 - SS15 (dark gray shading)
 Sector SA255 is split up into sub-sectors SS16 - SS31 (light gray shading)

9. Command Definitions

The host system must shift all commands, addresses, and data in and out of the device, beginning with the most significant bit. On the first rising edge of SCK after CS# is driven low, the device accepts the one-byte command on SI (all commands are one byte long), most significant bit first. Each successive bit is latched on the rising edge of SCK. [Table 9.1](#) lists the complete set of commands.

Every command sequence begins with a one-byte command code. The command may be followed by address, data, both, or nothing, depending on the command. CS# must be driven high after the last bit of the command sequence has been written.

The Read Data Bytes (READ), Read Data Bytes at Higher Speed (FAST_READ), Dual Output Read (DOR), Quad Output Read (QOR), Dual I/O High Performance Read (DIOR), Quad I/O High Performance Read (QIOR), Read Status Register (RDSR), Read Configuration Register (RCR), Read OTP Data (OTPR), Read Manufacturer and Device ID (READ_ID), Read Identification (RDID) and Release from Deep Power-Down and Read Electronic Signature (RES) command sequences are followed by a data output sequence on SO. CS# can be driven high after any bit of the sequence is output to terminate the operation.

The Page Program (PP), Quad Page Program (QPP), 64 KB Sector Erase (SE), 4 KB Parameter Sector Erase (P4E), 8 KB Parameter Sector Erase (P8E), Bulk Erase (BE), Write Status and Configuration Registers (WRR), Program OTP space (OTPP), Write Enable (WREN), or Write Disable (WRDI) commands require that CS# be driven high at a byte boundary, otherwise the command is not executed. Since a byte is composed of eight bits, CS# must therefore be driven high when the number of clock pulses after CS# is driven low is an exact multiple of eight.

The device ignores any attempt to access the memory array during a Write Registers, program, or erase operation, and continues the operation uninterrupted.

The instruction set is listed in [Table 9.1](#).

Table 9.1 Instruction Set

Operation	Command	One byte Command Code	Description	Address Byte Cycle	Mode Bit Cycle	Dummy Byte Cycle	Data Byte Cycle
Read	READ	(03h) 0000 0011	Read Data bytes	3	0	0	1 to ∞
	FAST_READ	(0Bh) 0000 1011	Read Data bytes at Fast Speed	3	0	1	1 to ∞
	DOR	(3Bh) 0011 1011	Dual Output Read	3	0	1	1 to ∞
	QOR	(6Bh) 0110 1011	Quad Output Read	3	0	1	1 to ∞
	DIOR	(BBh) 1011 1011	Dual I/O High Performance Read	3	1	0	1 to ∞
	QIOR	(EBh) 1110 1011	Quad I/O High Performance Read	3	1	2	1 to ∞
	RDID	(9Fh) 1001 1111	Read Identification	0	0	0	1 to 81
	READ_ID	(90h) 1001 0000	Read Manufacturer and Device Identification	3	0	0	1 to ∞
Write Control	WREN	(06h) 0000 0110	Write Enable	0	0	0	0
	WRDI	(04h) 0000 0100	Write Disable	0	0	0	0
Erase	P4E (1)	(20h) 0010 0000	4 KB Parameter Sector Erase	3	0	0	0
	P8E (1)	(40h) 0100 0000	8 KB (two 4KB) Parameter Sector Erase	3	0	0	0
	SE	(D8h) 1101 1000	64 KB and 256 KB Sector Erase	3	0	0	0
	BE	(60h) 0110 0000 or (C7h) 1100 0111	Bulk Erase	0	0	0	0
Program	PP	(02h) 0000 0010	Page Programming	3	0	0	1 to 256
	QPP	(32h) 0011 0010	Quad Page Programming	3	0	0	1 to 256
Status and Configuration Register	RDSR	(05h) 0000 0101	Read Status Register	0	0	0	1 to ∞
	WRR	(01h) 0000 0001	Write (Status and Configuration) Register	0	0	0	1 to 2
	RCR	(35h) 0011 0101	Read Configuration Register (CFG)	0	0	0	1 to ∞
	CLSR	(30h) 0011 0000	Reset the Erase and Program Fail Flag (SRS and SR6) and restore normal operation)	0	0	0	0
Power Saving	DP	(B9h) 1011 1001	Deep Power-Down	0	0	0	0
		(ABh) 1010 1011	Release from Deep Power-Down Mode	0	0	0	0
	RES	(ABh) 1010 1011	Release from Deep Power-Down and Read Electronic Signature	0	0	3	1 to ∞
OTP	OTPP	(42h) 0100 0010	Program one byte of data in OTP memory space	3	0	0	1
	OTPR	(4Bh) 0100 1011	Read data in the OTP memory space	3	0	1	1 to ∞

Note

1. For uniform 64 KB sector device only.

9.1 Read Data Bytes (READ)

The Read Data Bytes (READ) command reads data from the memory array at the frequency (f_R) presented at the SCK input, with a maximum speed of 40 MHz. The host system must first select the device by driving CS# low. The READ command is then written to SI, followed by a 3 byte address (A23-A0). Each bit is latched on the rising edge of SCK. The memory array data, at that address, are output serially on SO at a frequency f_R , on the falling edge of SCK.

Figure 9.1 and Table 9.1 on page 21 detail the READ command sequence. The first address byte specified can start at any location of the memory array. The device automatically increments to the next higher address after each byte of data is output. The entire memory array can therefore be read with a single READ command. When the highest address is reached, the address counter reverts to 00000h, allowing the read sequence to continue indefinitely.

The READ command is terminated by driving CS# high at any time during data output. The device rejects any READ command issued while it is executing a program, erase, or Write Registers operation, and continues the operation uninterrupted.

Figure 9.1 Read Data Bytes (READ) Command Sequence

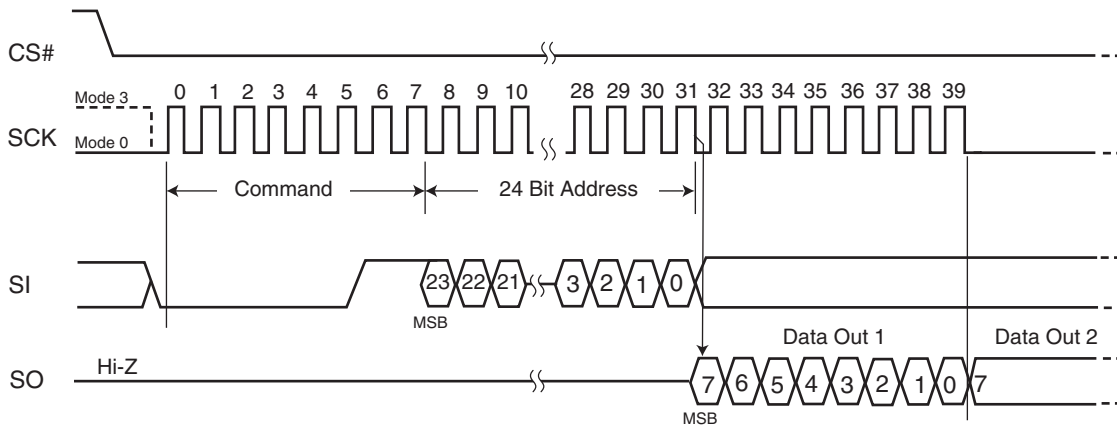

9.2 Read Data Bytes at Higher Speed (FAST_READ)

The FAST_READ command reads data from the memory array at the frequency (f_C) presented at the SCK input, with a maximum speed of 104 MHz. The host system must first select the device by driving CS# low. The FAST_READ command is then written to SI, followed by a 3 byte address (A23-A0) and a dummy byte. Each bit is latched on the rising edge of SCK. The memory array data, at that address, are output serially on SO at a frequency f_C , on the falling edge of SCK.

The FAST_READ command sequence is shown in Figure 9.2 and Table 9.1 on page 21. The first address byte specified can start at any location of the memory array. The device automatically increments to the next higher address after each byte of data is output. The entire memory array can therefore be read with a single FAST_READ command. When the highest address is reached, the address counter reverts to 000000h, allowing the read sequence to continue indefinitely.

The FAST_READ command is terminated by driving CS# high at any time during data output. The device rejects any FAST_READ command issued while it is executing a program, erase, or Write Registers operation, and continues the operation uninterrupted.

Figure 9.2 Read Data Bytes at Higher Speed (FAST_READ) Command Sequence

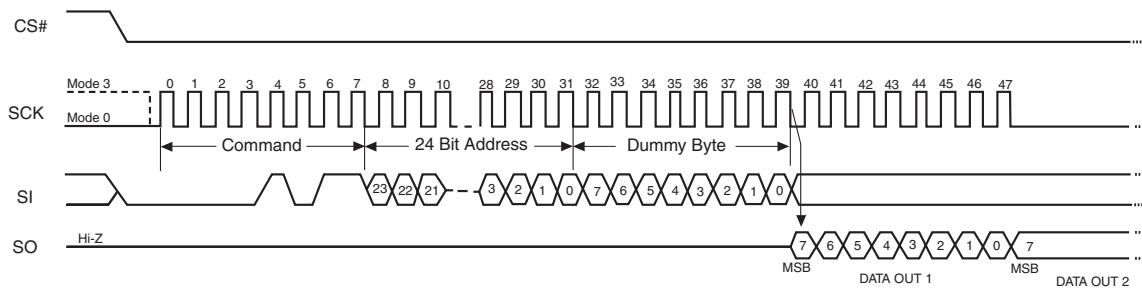

9.3 Dual Output Read Mode (DOR)

The Dual Output Read instruction is similar to the FAST_READ instruction, except that the data is shifted out 2 bits at a time using 2 pins (SI/IO0 and SO/IO1) instead of 1 bit, at a maximum frequency of 80 MHz. The Dual Output Read mode effectively doubles the data transfer rate compared to the FAST_READ instruction.

The host system must first select the device by driving CS# low. The Dual Output Read command is then written to SI, followed by a 3-byte address (A23-A0) and a dummy byte. Each bit is latched on the rising edge of SCK. Then the memory contents, at the address that is given, are shifted out two bits at a time through the IO0 (SI) and IO1 (SO) pins at a frequency f_C on the falling edge of SCK.

The Dual Output Read command sequence is shown in Figure 9.3 and Table 9.1 on page 21. The first address byte specified can start at any location of the memory array. The device automatically increments to the next higher address after each byte of data is output. The entire memory array can therefore be read with a single Dual Output Read command. When the highest address is reached, the address counter reverts to 00000h, allowing the read sequence to continue indefinitely.

It is important that the I/O pins be set to high-impedance prior to the falling edge of the first data out clock.

The Dual Output Read command is terminated by driving CS# high at any time during data output. The device rejects any Dual Output Read command issued while it is executing a program, erase, or Write Registers operation, and continues the operation uninterrupted.

Figure 9.3 Dual Output Read Instruction Sequence

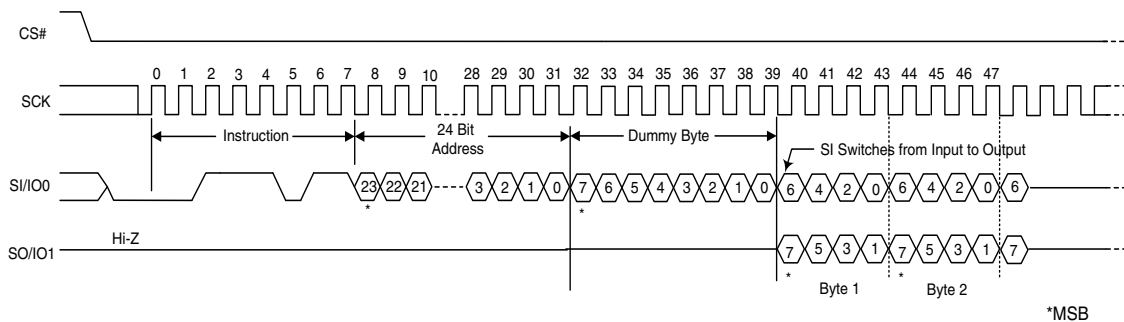

9.4 Quad Output Read Mode (QOR)

The Quad Output Read instruction is similar to the FAST_READ instruction, except that the data is shifted out 4 bits at a time using 4 pins (SI/IO0, SO/IO1, W#/ACC/IO2 and HOLD#/IO3) instead of 1 bit, at a maximum frequency of 80 MHz. The Quad Output Read mode effectively doubles the data transfer rate compared to the Dual Output Read instruction, and is four times the data transfer rate of the FAST_READ instruction.

The host system must first select the device by driving CS# low. The Quad Output Read command is then written to SI, followed by a 3-byte address (A23-A0) and a dummy byte. Each bit is latched on the rising edge of SCK. Then the memory contents, at the address that are given, are shifted out four bits at a time through IO0 (SI), IO1 (SO), IO2 (W#/ACC), and IO3 (HOLD#) pins at a frequency f_C on the falling edge of SCK.

The Quad Output Read command sequence is shown in Figure 9.4 and Table 9.1 on page 21. The first address byte specified can start at any location of the memory array. The device automatically increments to the next higher address after each byte of data is output. The entire memory array can therefore be read with a single Quad Output Read command. When the highest address is reached, the address counter reverts to 00000h, allowing the read sequence to continue indefinitely.

It is important that the I/O pins be set to high-impedance prior to the falling edge of the first data out clock.

The Quad Output Read command is terminated by driving CS# high at any time during data output. The device rejects any Quad Output Read command issued while it is executing a program, erase, or Write Registers operation, and continues the operation uninterrupted.

The Quad bit of Configuration Register must be set (CR Bit1 = 1) to enable the Quad mode capability of the S25FL device.

Figure 9.4 Quad Output Read Instruction Sequence

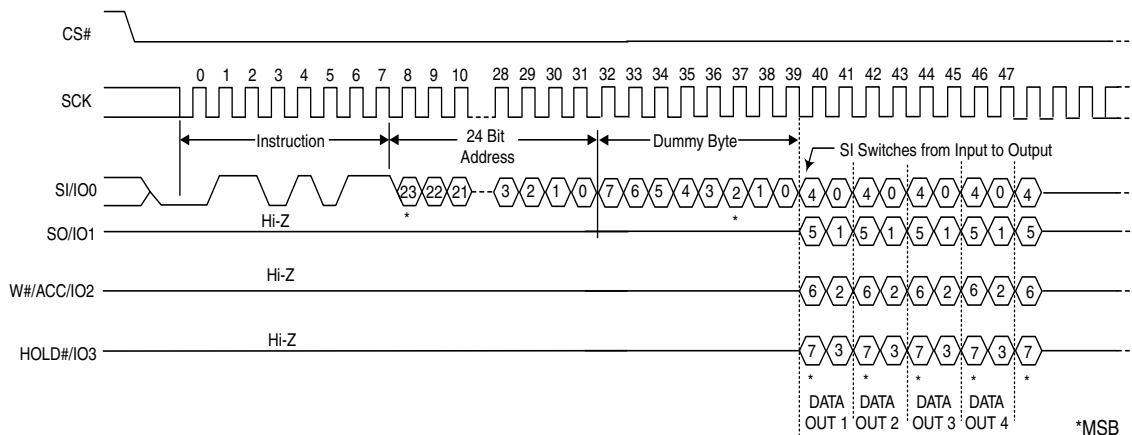

9.5 DUAL I/O High Performance Read Mode (DIOR)

The Dual I/O High Performance Read instruction is similar to the Dual Output Read instruction, except that it improves throughput by allowing input of the address bits (A23-A0) using two bits per SCK via two input pins (SI/IO2 and SO/IO1), at a maximum frequency of 80 MHz.

The host system must first select the device by driving CS# low. The Dual I/O High Performance Read command is then written to SI, followed by a 3-byte address (A23-A0) and a 1-byte Mode instruction, with two bits latched on the rising edge of SCK. Then the memory contents, at the address that is given, are shifted out two bits at a time through IO0 (SI) and IO1 (SO).

The DUAL I/O High Performance Read command sequence is shown in Figure 9.5 and Table 9.1 on page 21. The first address byte specified can start at any location of the memory array. The device automatically increments to the next higher address after each byte of data is output. The entire memory array can therefore be read with a single DUAL I/O High Performance Read command. When the highest address is reached, the address counter reverts to 00000h, allowing the read sequence to continue indefinitely.

In addition, address jumps can be done without exiting the Dual I/O High Performance Mode through the setting of the Mode bits (after the Address (A23-0) sequence, as shown in Figure 9.5). This added feature removes the need for the instruction sequence and greatly improves code execution (XIP). The upper nibble (bits 7-4) of the Mode bits control the length of the next Dual I/O High Performance instruction through the inclusion or exclusion of the first byte instruction code. The lower nibble (bits 3-0) of the Mode bits are DON'T CARE ("x"). If the Mode bits equal Axh, then the device remains in Dual I/O High Performance Read Mode and the next address can be entered (after CS# is raised high and then asserted low) without requiring the BBh instruction opcode, as shown in Figure 9.6, thus eliminating eight cycles for the instruction sequence. However, if the Mode bits are any value other than Axh, then the next instruction (after CS# is raised high and then asserted low) requires the instruction sequence, which is normal operation. The following sequences will release the device from Dual I/O High Performance Read mode; after which, the device can accept standard SPI instructions:

1. During the Dual I/O High Performance Instruction Sequence, if the Mode bits are any value other than Axh, then the next time CS# is raised high and then asserted low, the device will be released from Dual I/O High Performance Read mode.
2. Furthermore, during any operation, if CS# toggles high to low to high for eight cycles (or less) **and** data input (IO0 and IO1) are not set for a valid instruction sequence, then the device will be released from Dual I/O High Performance Read mode.

It is important that the I/O pins be set to high-impedance prior to the falling edge of the first data out clock.

The read instruction can be terminated by driving the CS# pin to the logic high state. The CS# pin can be driven high at any time during data output to terminate a read operation.

Figure 9.5 DUAL I/O High Performance Read Instruction Sequence



Figure 9.6 Continuous Dual I/O High Performance Read Instruction Sequence

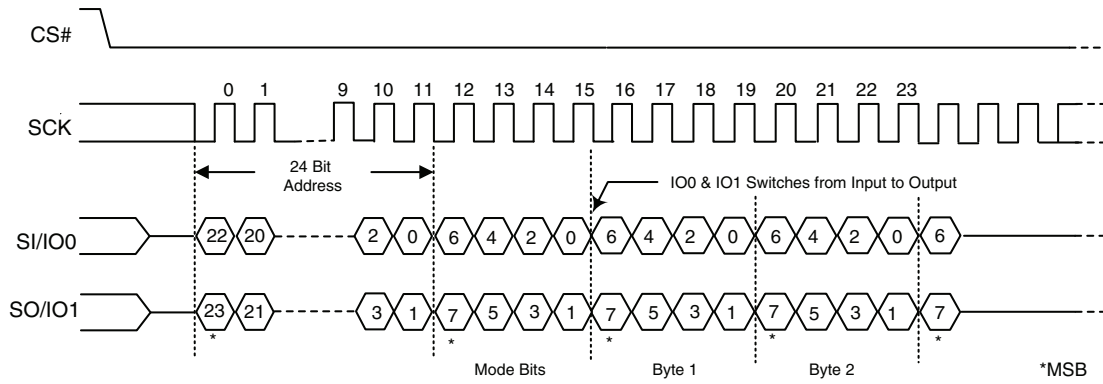

9.6 Quad I/O High Performance Read Mode (QIOR)

The Quad I/O High Performance Read instruction is similar to the Quad Output Read instruction, except that it further improves throughput by allowing input of the address bits (A23-A0) using 4 bits per SCK via four input pins (SI/IO0, SO/IO1, W#/ACC/IO2 and HOLD#/IO3), at a maximum frequency of 80 MHz.

The host system must first select the device by driving CS# low. The Quad I/O High Performance Read command is then written to SI, followed by a 3-byte address (A23-A0) and a 1-byte Mode instruction, with four bits latched on the rising edge of SCK. Note that four dummy clocks are required prior to the data input. Then the memory contents, at the address that is given, are shifted out four bits at a time through IO0 (SI), IO1 (SO), IO2 (W#/ACC), and IO3 (HOLD#).

The Quad I/O High Performance Read command sequence is shown in Figure 9.7 and Table 9.1 on page 21. The first address byte specified can start at any location of the memory array. The device automatically increments to the next higher address after each byte of data is output. The entire memory array can therefore be read with a single Quad I/O High Performance Read command. When the highest address is reached, the address counter reverts to 00000h, allowing the read sequence to continue indefinitely.

In addition, address jumps can be done without exiting the Quad I/O High Performance Mode through the setting of the Mode bits (after the Address (A23-0) sequence, as shown in Figure 9.7). This added feature removes the need for the instruction sequence and greatly improves code execution (XIP). The upper nibble (bits 7-4) of the Mode bits control the length of the next Quad I/O High Performance instruction through the inclusion or exclusion of the first byte instruction code. The lower nibble (bits 3-0) of the Mode bits are DON'T CARE ("x"). If the Mode bits equal Axh, then the device remains in Quad I/O High Performance Read Mode and the next address can be entered (after CS# is raised high and then asserted low) without requiring the EBh instruction opcode, as shown in Figure 9.8, thus eliminating eight cycles for the instruction sequence. The following sequences will release the device from Quad I/O High Performance Read mode; after which, the device can accept standard SPI instructions:

1. During the Quad I/O High Performance Instruction Sequence, if the Mode bits are any value other than Axh, then the next time CS# is raised high and then asserted low the device will be released from Quad I/O High Performance Read mode.
2. Furthermore, during any operation, if CS# toggles high to low to high for eight cycles (or less) **and** data input (IO0, IO1, IO2, and IO3) are not set for a valid instruction sequence, then the device will be released from Quad I/O High Performance Read mode.

It is important that the I/O pins be set to high-impedance prior to the falling edge of the first data out clock.

The read instruction can be terminated by driving the CS# pin to the logic high state. The CS# pin can be driven high at any time during data output to terminate a read operation.

Figure 9.7 QUAD I/O High Performance Instruction Sequence

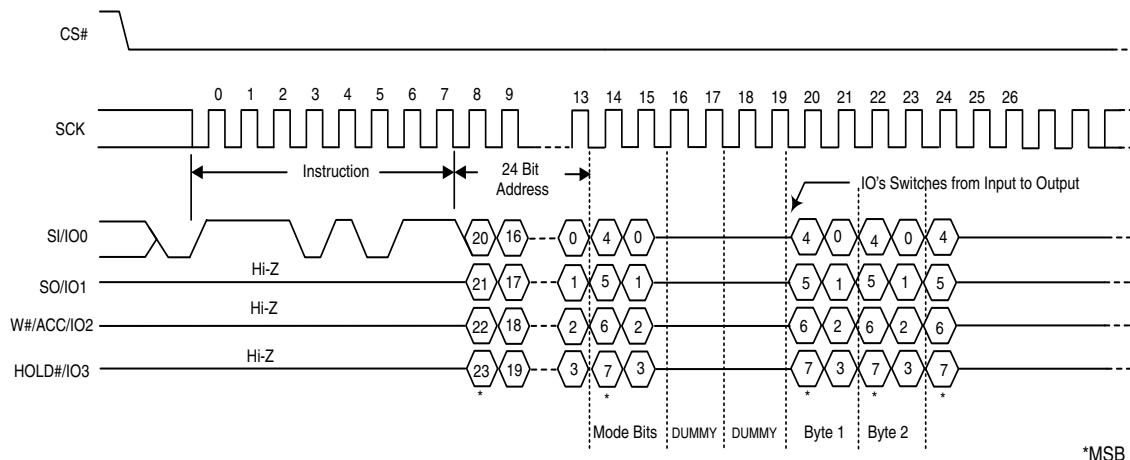
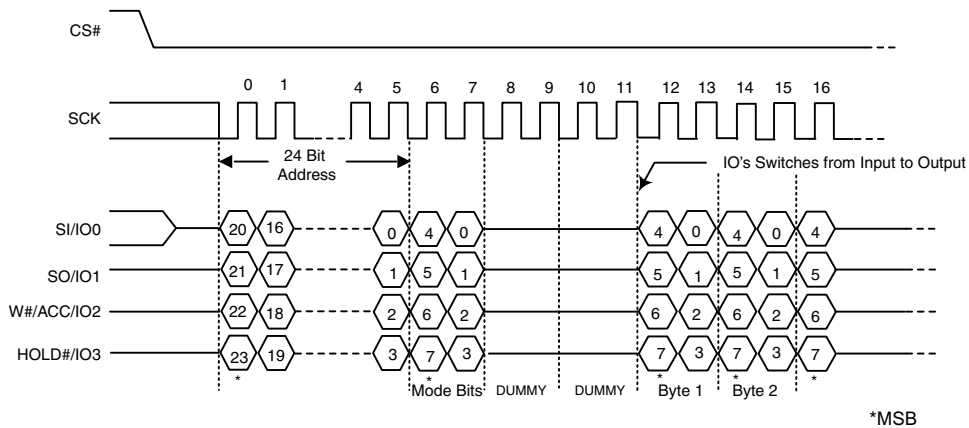

Figure 9.8 Continuous QUAD I/O High Performance Instruction Sequence



9.7 Read Identification (RDID)

The Read Identification (RDID) command outputs the one-byte manufacturer identification, followed by the two-byte device identification and the bytes for the Common Flash Interface (CFI) tables. The manufacturer identification is assigned by JEDEC; for Cypress devices, it is 01h. The device identification (2 bytes) and CFI bytes are assigned by the device manufacturer.

See [Table 9.2 on page 30](#) for device ID data.

The Common Flash Interface (CFI) specification outlines device and host system software interrogation handshake, which allows vendor-specified software algorithms to be used for entire families of devices. Software support can then be device-independent, JEDEC ID-independent, and forward- and backward-compatible for the specified flash device families. Flash vendors can standardize their existing interfaces for long-term compatibility. The system can read CFI information at the addresses given in [Table 9.3](#).

The host system must first select the device by driving CS# low. The RDID command is then written to SI, and each bit is latched on the rising edge of SCK. One byte of manufacture identification, two bytes of device identification and sixty-six bytes of extended device identification are then output from the memory array on SO at a frequency f_R , on the falling edge of SCK. The maximum clock frequency for the RDID (9Fh) command is 50 MHz (Normal Read). The manufacturer ID and Device ID can be read repeatedly by applying multiples of six hundred and forty eight clock cycles. The manufacturer ID, Device ID and CFI table can be continuously read as long as CS# is held low with a clock input.

The RDID command sequence is shown in [Figure 9.9](#) and [Table 9.1 on page 21](#).

Driving CS# high after the device identification data has been read at least once terminates the RDID command. Driving CS# high at any time during data output (for example, while reading the extended CFI bytes), also terminates the RDID operation.

The device rejects any RDID command issued while it is executing a program, erase, or Write Registers operation, and continues the operation uninterrupted.

Figure 9.9 Read Identification (RDID) Command Sequence and Data-Out Sequence

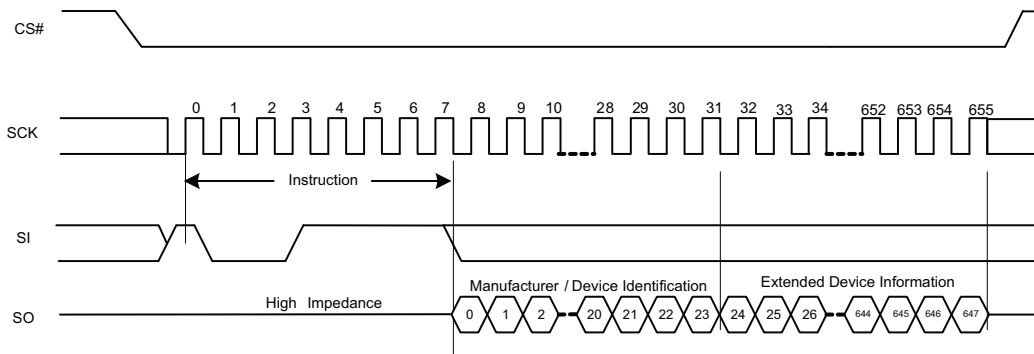

Table 9.2 Manufacturer and Device Identification - RDID (9Fh):

Device	Manufacturer Identification	Device Identification		Extended Device Identification	
	Byte 0	Byte 1	Byte 2	Byte 3	Byte 4
Uniform 256 KB Sector	01h	20h	18h	4Dh	00h
Uniform 64 KB Sector	01h	20h	18h	4Dh	01h

Notes

1. Byte 0 is Manufacturer ID of Spansion.
2. Byte 1 and 2 is Device Id.
3. Byte 3 is Extended Device Information String Length, to indicate how many Extended Device Information bytes will follow.
4. Byte 4 indicates uniform 64 KB sector or uniform 256 KB sector device.
5. Bytes 5 and 6 are Spansion reserved (do not use).
6. For Bytes 07h-0Fh and 3Dh-3Fh, the data will be read as 0xFF.
7. Bytes 10h-50h are factory programmed per JEDEC standard.

Table 9.3 Product Group CFI Query Identification String

Byte	Data	Description
10h	51h	Query Unique ASCII string "QRY"
11h	52h	
12h	59h	
13h	02h	Primary OEM Command Set
14h	00h	
15h	40h	Address for Primary Extended Table
16h	00h	
17h	00h	Alternate OEM Command Set (00h = none exists)
18h	00h	
19h	00h	Address for Alternate OEM Extended Table (00h = none exists)
1Ah	00h	

Table 9.4 Product Group CFI System Interface String

Byte	Data	Description
1Bh	27h	V _{CC} Min. (erase/program): (D7-D4: Volt, D3-D0: 100 mV)
1Ch	36h	V _{CC} Max. (erase/program): (D7-D4: Volt, D3-D0: 100 mV)
1Dh	00h	V _{PP} Min. voltage (00h = no VPP pin present)
1Eh	00h	V _{PP} Max. voltage (00h = no VPP pin present)
1Fh	0Bh	Typical timeout per single byte program 2 ^N μs
20h	0Bh	Typical timeout for Min. size Page program 2 ^N μs (00h = not supported)
21h	09h	Typical timeout per individual sector erase 2 ^N ms
22h	11h	Typical timeout for full chip erase 2 ^N ms (00h = not supported)
23h	01h	Max. timeout for byte program 2 ^N times typical
24h	01h	Max. timeout for page program 2 ^N times typical
25h	02h	Max. timeout per individual sector erase 2 ^N times typical
26h	01h	Max. timeout for full chip erase 2 ^N times typical (00h = not supported)

Table 9.5 Product Group CFI Device Geometry Definition

Byte	Data	Description
27h	18h	Device Size = 2 ^N byte;
28h	05h	Flash Device Interface Description; 00h = x8 only 01h = x16 only 02h = x8/x16 capable 03h = x32 only 04h = Single I/O SPI, 3-byte address 05h = Multi I/O SPI, 3-byte address
29h	05h	
2Ah	08h	
2Bh	00h	
2Ch	02h (uniform 64 KB sector) 01h (uniform 256 KB sector)	
2Dh	1Fh (uniform 64 KB sector) 3Fh (uniform 256 KB sector)	Number of Erase Block Regions within device 1 = Uniform Device, 2 = Parameter Block
2Eh	00h	
2Fh	10h (uniform 64 KB sector) 00h (uniform 256 KB sector)	Erase Block Region 1 Information (refer to CFI publication 100)
30h	00h (uniform 64 KB sector) 04h (uniform 256 KB sector)	
31h	FDh (uniform 64 KB sector) 00h (uniform 256 KB sector)	
32h	00h	Erase Block Region 2 Information (refer to CFI publication 100)
33h	00h	
34h	01h (uniform 64 KB sector) 00h (uniform 256 KB sector)	
35h	00h	Erase Block Region 3 Information (refer to CFI publication 100)
36h	00h	
37h	00h	
38h	00h	
39h	00h	
3Ah	00h	Erase Block Region 4 Information (refer to CFI publication 100)
3Bh	00h	
3Ch	00h	

Table 9.6 Product Group CFI Primary Vendor-Specific Extended Query

Byte	Data	Description
40h	50h	Query-unique ASCII string "PRI"
41h	52h	
42h	49h	
43h	31h	Major version number, ASCII
44h	33h	Minor version number, ASCII
45h	15h	Address Sensitive Unlock (Bits 1-0) 00b = Required, 01b = Not Required Process Technology (Bits 5-2) 0000b = 0.23 μ m Floating Gate 0001b = 0.17 μ m Floating Gate 0010b = 0.23 μ m MirrorBit 0010b = 0.20 μ m MirrorBit 0011b = 0.11 μ m Floating Gate 0100b = 0.11 μ m MirrorBit 0101b = 0.09 μ m MirrorBit 1000b = 0.065 μ m MirrorBit
46h	00h	Erase Suspend 0 = Not Supported, 1 = Read Only, 2 = Read and Write
47h	04h	Sector Protect 00 = Not Supported, X = Number of sectors in per smallest group
48h	00h	Temporary Sector Unprotect 00 = Not Supported, 01 = Supported
49h	05h	Sector Protect/Unprotect Scheme 04 = High Voltage Method 05 = Software Command Locking Method 08 = Advanced Sector Protection Method
4Ah	00h	Simultaneous Operation 00 = Not Supported, X = Number of Sectors outside Bank 1
4Bh	01h	Burst Mode Type 00 = Not Supported, 01 = Supported
4Ch	03h	Page Mode Type 00 = Not Supported, 01 = 4 Word Page, 02 = 8 Word Page, 03 = 256 Byte Page
4Dh	85h	ACC (Acceleration) Supply Minimum 00 = Not Supported, (D7-D4: Volt, D3-D0: 100 mV)
4Eh	95h	ACC (Acceleration) Supply Maximum 00 = Not Supported, (D7-D4: Volt, D3-D0: 100 mV)
4Fh	07h	W# Protection 07 = Uniform Device with Top or Bottom Write Protect (user select)
50h	00h	Program Suspend 00 = Not Supported, 01 = Supported

Note

CFI data related to V_{CC} and time-outs may differ from actual V_{CC} and time-outs of the product. Please consult the Ordering Information tables to obtain the V_{CC} range for particular part numbers. Please consult the AC Characteristics on page 57 for typical timeout specifications.

9.8 Read-ID (READ_ID)

The READ_ID instruction provides the S25FL129P manufacturer and device information and is provided as an alternative to the Release from Deep Power-Down and Read Electronic Signature (RES), and the JEDEC Read Identification (RDID) commands.

The instruction is initiated by driving the CS# pin low and shifting in (via the SI input pin) the instruction code “90h” followed by a 24-bit address (which is either 00000h or 00001h). Following this, the Manufacturer ID and the Device ID are shifted out on the SO output pin starting after the falling edge of the SCK serial clock input signal. If the 24-bit address is set to 000000h, the Manufacturer ID is read out first followed by the Device ID. If the 24-bit address is set to 000001h, then the Device ID is read out first followed by the Manufacturer ID. The Manufacturer ID and the Device ID are always shifted out on the SO output pin with the MSB first, as shown in Figure 9.10. Once the device is in Read-ID mode, the Manufacturer ID and Device ID output data toggles between address 000000H and 000001H until terminated by a low to high transition on the CS# input pin. The maximum clock frequency for the Read-ID (90h) command is at 104 MHz (FAST_READ). The Manufacturer ID and Device ID is output continuously until terminated by a low to high transition on CS# chip select input pin.

Figure 9.10 Read-ID (RDID) Command Timing Diagram



Table 9.7 READ_ID Data-Out Sequence

	Address	Data
Manufacturer Identification	00000h	01h
Device Identification	00001h	17h

9.9 Write Enable (WREN)

The Write Enable (WREN) command (see [Figure 9.11](#)) sets the Write Enable Latch (WEL) bit to a 1, which enables the device to accept a Write Status Register, program, or erase command. The WEL bit must be set prior to every Page Program (PP), Quad Page Program (QPP), Parameter Sector Erase (P4E, P8E), Erase (SE or BE), Write Registers (WRR) and OTP Program (OTPP) command.

The host system must first drive CS# low, write the WREN command, and then drive CS# high.

Figure 9.11 Write Enable (WREN) Command Sequence

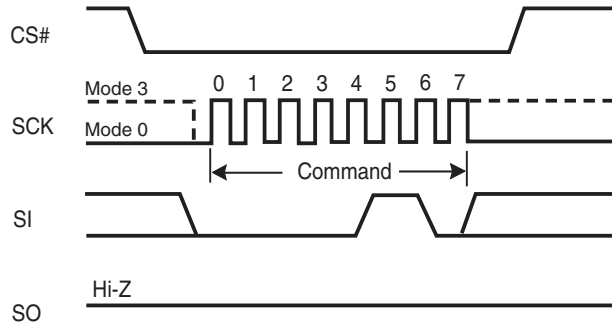

9.10 Write Disable (WRDI)

The Write Disable (WRDI) command (see [Figure 9.12](#)) resets the Write Enable Latch (WEL) bit to a 0, which disables the device from accepting a Page Program (PP), Quad Page Program (QPP), Parameter Sector Erase (P4E, P8E), Erase (SE, BE), Write Registers (WRR) and OTP Program (OTPP) command. The host system must first drive CS# low, write the WRDI command, and then drive CS# high.

Any of following conditions resets the WEL bit:

- Power-up
- Write Disable (WRDI) command completion
- Write Registers (WRR) command completion
- Page Program (PP) command completion
- Quad Page Program (QPP) completion
- Parameter Sector Erase (P4E, P8E) completion (applicable for the uniform 64 KB sector device only)
- Sector Erase (SE) command completion
- Bulk Erase (BE) command completion
- OTP Program (OTPP) completion

Figure 9.12 Write Disable (WRDI) Command Sequence

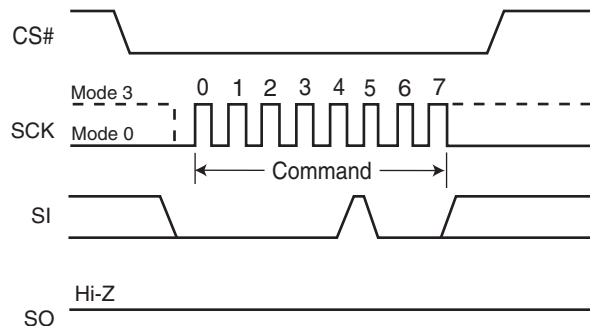

9.11 Read Status Register (RDSR)

The Read Status Register (RDSR) command outputs the state of the Status Register bits. Table 9.8 shows the status register bits and their functions. The RDSR command may be written at any time, even while a program, erase, or Write Registers operation is in progress. The host system should check the Write In Progress (WIP) bit before sending a new command to the device if an operation is already in progress. Figure 9.13 shows the RDSR command sequence, which also shows that it is possible to read the Status Register continuously until CS# is driven high. The maximum clock frequency for the RDSR command is 104 MHz.

Table 9.8 S25FL129P Status Register

Bit	Status Register Bit	Bit Function	Description
7	SRWD	Status Register Write Disable	1 = Protects when W#/ACC is low 0 = No protection, even when W#/ACC is low
6	P_ERR	Programming Error Occurred	0 = No Error 1 = Error occurred
5	E_ERR	Erase Error Occurred	0 = No Error 1 = Error occurred
4	BP2	Block Protect	Protects selected Blocks from Program or Erase
3	BP1		
2	BP0		
1	WEL	Write Enable Latch	1 = Device accepts Write Registers, program or erase commands 0 = Ignores Write Registers, program or erase commands
0	WIP	Write in Progress	1 = Device Busy a Write Registers, program or erase operation is in progress 0 = Ready. Device is in standby mode and can accept commands.

Figure 9.13 Read Status Register (RDSR) Command Sequence

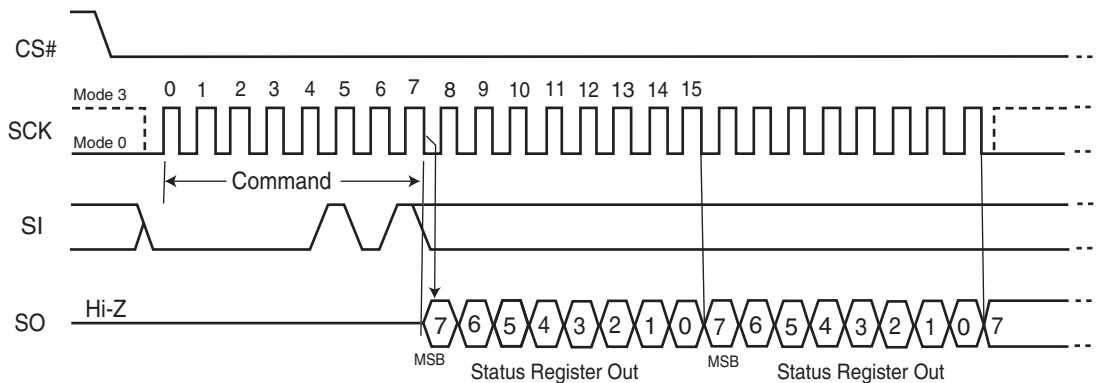

The following describes the status and control bits of the Status Register.

Write In Progress (WIP) bit: Indicates whether the device is busy performing a Write Registers, program, or erase operation. This bit is read-only, and is controlled internally by the device. If WIP is 1, one of these operations is in progress; if WIP is 0, no such operation is in progress. This bit is a Read-only bit.

Write Enable Latch (WEL) bit: Determines whether the device will accept and execute a Write Registers, program, or erase command. When set to 1, the device accepts these commands; when set to 0, the device rejects the commands. This bit is set to 1 by writing the WREN command, and set to 0 by the WRDI command, and is also automatically reset to 0 after the completion of a Write Registers, program, or erase operation, and after a power down/power up sequence. WEL cannot be directly set by the WRR command.

Block Protect (BP2, BP1, BP0) bits: Define the portion of the memory area that will be protected against any changes to the stored data. The Block Protection (BP2, BP1, BP0) bits are either volatile or non-volatile, depending on the state of the non-volatile bit BPNV in the Configuration register. The Block Protection (BP2, BP1, BP0) bits are written with the Write Registers (WRR)

instruction. When one or more of the Block Protect (BP2, BP1, BP0) bits is set to 1's, the relevant memory area is protected against Page Program (PP), Parameter Sector Erase (P4E, P8E), Sector Erase (SE), Quad Page Programming (QPP) and Bulk Erase (BE) instructions. If the Hardware Protected mode is enabled, BP2:BP0 cannot be changed.

The Bulk Erase (BE) instruction can be executed only when the Block Protection (BP2, BP1, BP0) bits are set to 0's.

The default condition of the BP2-0 bits is binary 000 (all 0's).

Erase Error bit (E_ERR): The Erase Error Bit is used as a Erase operation success and failure check. When the Erase Error bit is set to a "1", it indicates that there was an error which occurred in the last erase operation. With the Erase Error bit set to a "1", this bit is reset with the Clear Status Register (CLSR) command.

Program Error bit (P_ERR): The Program Error Bit is used as a Program operation success and failure check. When the Program Error bit is set to a "1", it indicates that there was an error which occurred in the last program operation. With the Program Error bit set to a "1", this bit is reset with the Clear Status Register (CLSR) command.

Status Register Write Disable (SRWD) bit: Provides data protection when used together with the Write Protect (W#/ACC) signal. The Status Register Write Disable (SRWD) bit is operated in conjunction with the Write Protect (W#/ACC) input pin. The Status Register Write Disable (SRWD) bit and the Write Protect (W#/ACC) signal allow the device to be put in the Hardware Protected mode. With the Status Register Write Disable (SRWD) bit set to a "1" and the W#/ACC driven to the logic low state, the device enters the Hardware Protected mode; the non-volatile bits of the Status Register (SRWD, BP2, BP1, BP0) and the nonvolatile bits of the Configuration Register (TBPARM, TBPROT, BPNV and QUAD) become read-only bits and the Write Registers (WRR) instruction opcode is no longer accepted for execution.

Note that the P_ERR and E_ERR bits will not be set to a 1 if the application writes to a protected memory area.

9.12 Read Configuration Register (RCR)

The Read Configuration Register (RCR) instruction opcode allows the Configuration Register contents to be read out of the SO serial output pin. The Configuration Register contents may be read at any time, even while a program, erase, or write cycle is in progress. When one of these cycles is in progress, it is recommended to the user to check the Write In Progress (WIP) bit of the Status Register before issuing a new instruction opcode to the device. The Configuration Register originally shows 00h when the device is first shipped from the factory to the customer. (Refer to Section 7.8 on page 11, Table 7.1 and Table 7.1 on page 12 for more details.)

Figure 9.14 Read Configuration Register (RCR) Instruction Sequence

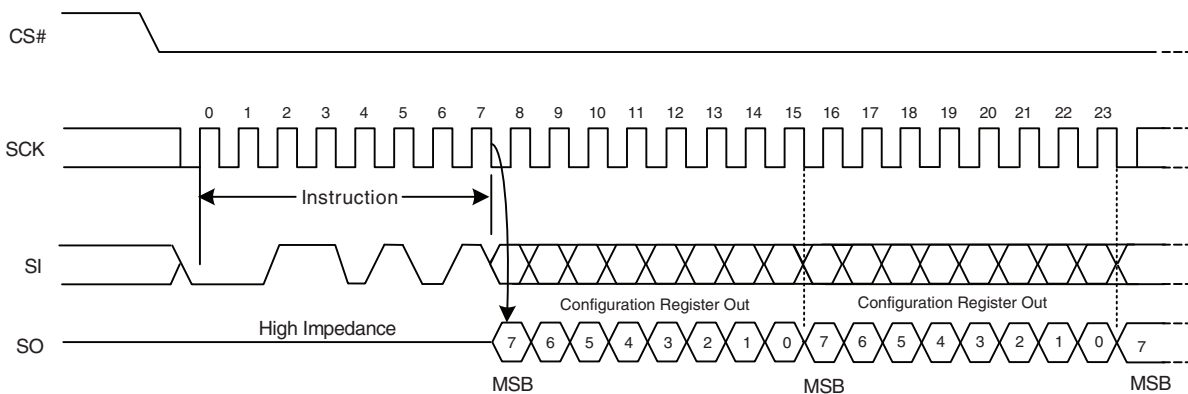

9.13 Write Registers (WRR)

The Write Registers (WRR) command allows changing the bits in the Status and Configuration Registers. A Write Enable (WREN) command, which itself sets the Write Enable Latch (WEL) in the Status Register, is required prior to writing the WRR command. [Table 9.8](#) shows the status register bits and their functions.

The host system must drive CS# low, then write the WRR command and the appropriate data byte on SI [Figure 9.15](#).

The WRR command cannot change the state of the Write Enable Latch (bit 1). The WREN command must be used for that purpose.

The Status Register consists of one data byte in length; similarly, the Configuration Register is also one data byte in length. The CS# pin must be driven to the logic low state during the entire duration of the sequence.

The WRR command also controls the value of the Status Register Write Disable (SRWD) bit. The SRWD bit and W#/ACC pin together place the device in the Hardware Protected Mode (HPM). The device ignores all WRR commands once it enters the Hardware Protected Mode (HPM). [Table 9.9](#) shows that W#/ACC must be driven low and the SRWD bit must be 1 for this to occur.

The Write Registers (WRR) instruction has no effect on the P/E Error and the WIP bits of the Status and Configuration Registers. Any bit reserved for the future is always read as a '0'

The CS# chip select input pin must be driven to the logic high state after the eighth (see [Figure 9.15](#)) or sixteenth (see [Figure 9.16](#)) bit of data has been latched in. If not, the Write Registers (WRR) instruction is not executed. If CS# is driven high after the eighth cycle then only the Status Register is written to; otherwise, after the sixteenth cycle both the Status and Configuration Registers are written to. As soon as the CS# chip select input pin is driven to the logic high state, the self-timed Write Registers cycle is initiated. While the Write Registers cycle is in progress, the Status Register may still be read to check the value of the Write In Progress (WIP) bit. The Write In Progress (WIP) bit is a '1' during the self-timed Write Registers cycle, and is a '0' when it is completed. When the Write Registers cycle is completed, the Write Enable Latch (WEL) is set to a '0'. The WRR command can operate at a maximum clock frequency of 104 MHz.

Figure 9.15 Write Registers (WRR) Instruction Sequence – 8 data bits

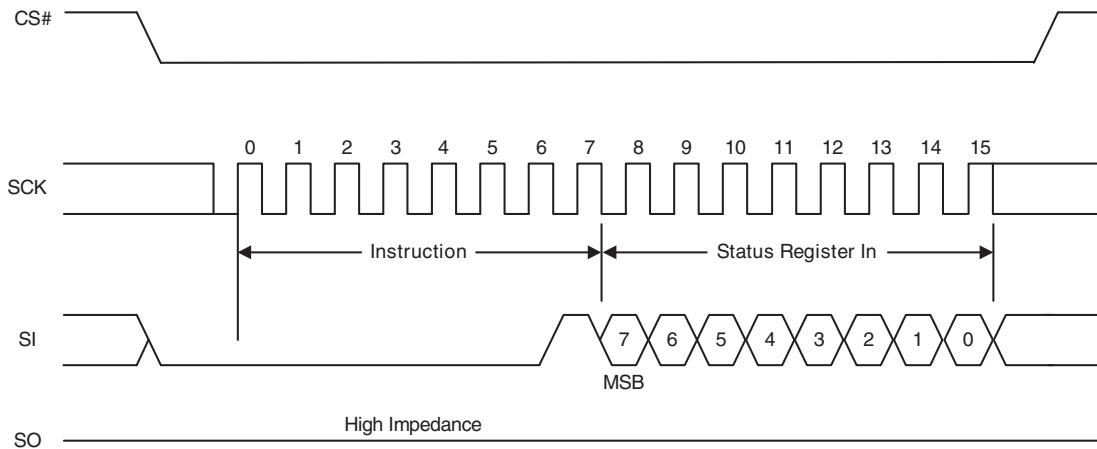

Figure 9.16 Write Registers (WRR) Instruction Sequence – 16 data bits



Table 9.9 Protection Modes

W#/ACC	SRWD Bit	Mode	Write Protection of Registers	Memory Content	
				Protected Area	Unprotected Area
1	1	Software Protected (SPM)	Status and Configuration Registers are Writable (if WREN instruction has set the WEL bit). The values in the SRWD, BP2, BP1, and BP0 bits and those in the Configuration Register can be changed	Protected against Page Program, Parameter Sector Erase, Sector Erase, and Bulk Erase	Ready to accept Page Program, Parameter Sector Erase, and Sector Erase instructions
1	0				
0	0	Hardware Protected (HPM)	Status and Configuration Registers are Hardware Write Protected. The values in the SRWD, BP2, BP1, and BP0 bits and those in the Configuration Register cannot be changed	Protected against Page Program, Sector Erase, and Bulk Erase	Ready to accept Page Program, Sector Erase instructions
0	1				

Note

As defined by the values in the Block Protect (BP2, BP1, BP0) bits of the Status Register, as shown in Table 7.3 on page 13.

Table 9.9 shows that neither W#/ACC or SRWD bit by themselves can enable HPM. The device can enter HPM either by setting the SRWD bit after driving W#/ACC low, or by driving W#/ACC low after setting the SRWD bit. However, the device disables HPM only when W#/ACC is driven high.

Note that HPM only protects against changes to the status register. Since BP2:BP0 cannot be changed in HPM, the size of the protected area of the memory array cannot be changed. Note that HPM provides no protection to the memory array area outside that specified by BP2:BP0 (Software Protected Mode, or SPM).

If W#/ACC is permanently tied high, HPM can never be activated, and only the SPM (Block Protect bits of the Status Register) can be used.

The Status and Configuration registers originally default to 00h, when the device is first shipped from the factory to the customer.

Note: HPM is disabled when the Quad I/O Mode is enabled (Quad bit = 1 in the Configuration Register). W# becomes IO2; therefore, HPM cannot be utilized.

9.14 Page Program (PP)

The Page Program (PP) command changes specified bytes in the memory array (from 1 to 0 only). A WREN command is required prior to writing the PP command.

The host system must drive CS# low, and then write the PP command, three address bytes, and at least one data byte on SI. If the 8 least significant address bits (A7-A0) are not all zero, all transmitted data that goes beyond the end of the currently selected page are programmed from the starting address of the same page (from the address whose 8 least significant bits are all zero). CS# must be driven low for the entire duration of the PP sequence. The command sequence is shown in [Figure 9.17](#) and [Table 9.1](#) on page 21.

The device programs only the last 256 data bytes sent to the device. If the 8 least significant address bits (A7-A0) are not all zero, all transmitted data that goes beyond the end of the currently selected page are programmed from the starting address of the same page (from the address whose 8 least significant bits are all zero). If fewer than 256 data bytes are sent to device, they are correctly programmed at the requested addresses without having any effect on the other bytes in the same page.

The host system must drive CS# high after the device has latched the 8th bit of the data byte, otherwise the device does not execute the PP command. The PP operation begins as soon as CS# is driven high. The device internally controls the timing of the operation, which requires a period of t_{PP} . The Status Register may be read to check the value of the Write In Progress (WIP) bit while the PP operation is in progress. The WIP bit is 1 during the PP operation, and is 0 when the operation is completed. The device internally resets the Write Enable Latch to 0 before the operation completes (the exact timing is not specified).

The device does not execute a Page Program (PP) command that specifies a page that is protected by the Block Protect bits (BP2:BP0) (see [Table 7.3](#) on page 13).

Figure 9.17 Page Program (PP) Command Sequence

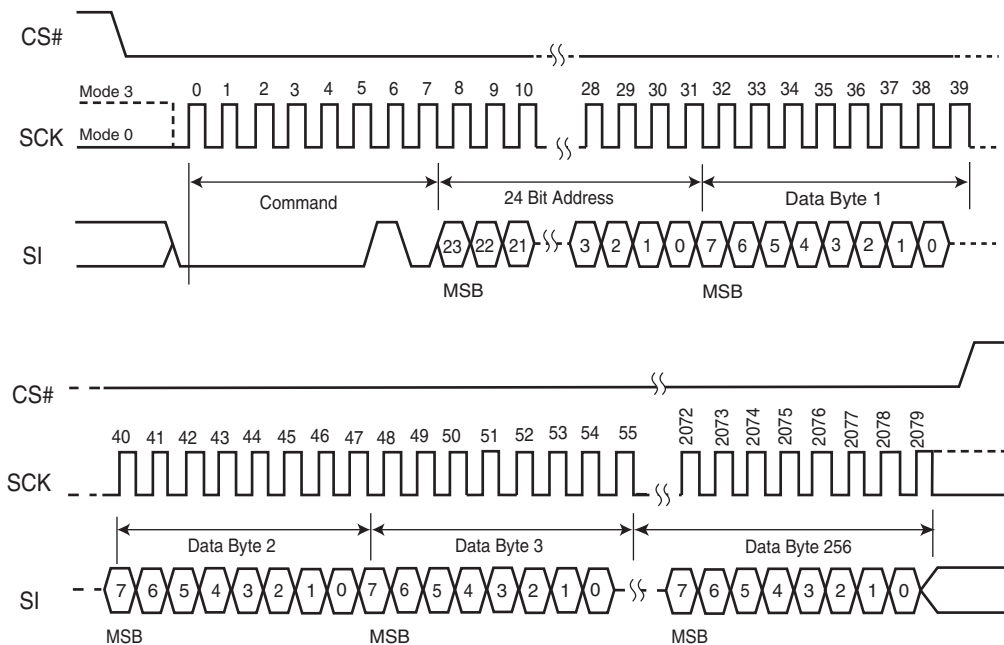

9.15 QUAD Page Program (QPP)

The Quad Page Program instruction is similar to the Page Program instruction, except that the Quad Page Program (QPP) instruction allows up to 256 bytes of data to be programmed at previously erased (FFh) memory locations using four pins: IO0 (SI), IO1 (SO), IO2 (W#/ACC), and IO3 (HOLD#), instead of just one pin (SI) as in the case of the Page Program (PP) instruction. This effectively increases the data transfer rate by up to four times, as compared to the Page Program (PP) instruction. The QPP feature can improve performance for PROM Programmer and applications that have slow clock speeds < 5 MHz. Systems with faster clock speed will not realize much benefit for the QPP instruction since the inherent page program time is much greater than the time it take to clock-in the data.

To use QPP, the Quad Enable Bit in the Configuration Register must be set (QUAD = 1). A Write Enable instruction must be executed before the device will accept the Quad Page Program instruction (Status Register-1, WEL = 1). The instruction is initiated by driving the CS# pin low then shifting the instruction code "32h" followed by a 24 bit address (A23-A0) and at least one data byte, into the IO pins. The CS# pin must be held low for the entire length of the instruction while data is being sent to the device. All other functions of Quad Input Page Program are identical to standard Page Program. The QPP instruction sequence is shown below.

Figure 9.18 QUAD Page Program Instruction Sequence

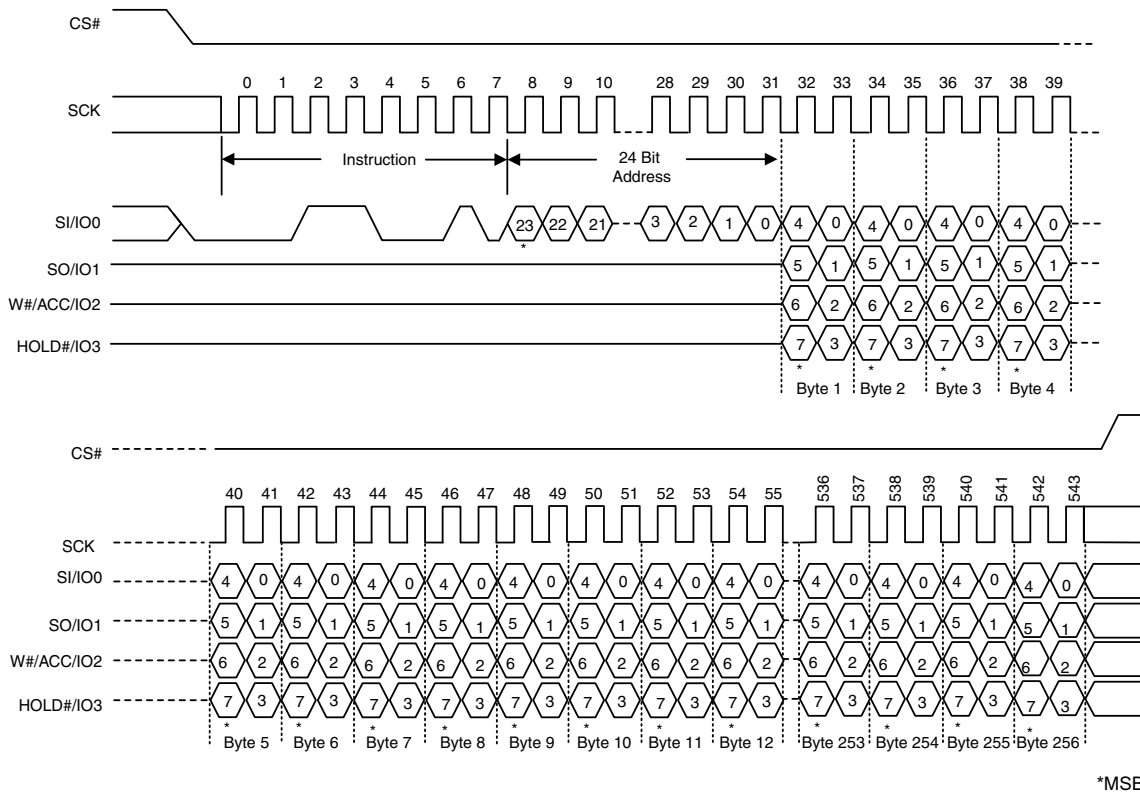

9.16 Parameter Sector Erase (P4E, P8E) (only applicable for the uniform 64 KB sector device)

The Parameter Sector Erase (P4E, P8E) command sets all bits at all addresses within a specified sector to a logic 1 (FFh). A WREN command is required prior to writing the Parameter Sector Erase commands.

The host system must drive CS# low, and then write the P4E or P8E command, plus three address bytes on SI. Any address within the sector (see Table 5.1 on page 8) is a valid address for the P4E or P8E command. CS# must be driven low for the entire duration of the P4E/P8E sequence. The command sequence is shown in Figure 9.19 and Table 9.1 on page 21.

The host system must drive CS# high after the device has latched the 24th bit of the P4E/P8E address, otherwise the device does not execute the command. The parameter sector erase operation begins as soon as CS# is driven high. The device internally controls the timing of the operation, which requires a period of t_{SE} . The Status Register may be read to check the value of the Write In Progress (WIP) bit while the parameter sector erase operation is in progress. The WIP bit is 1 during the P4E/P8E operation, and is 0 when the operation is completed. The device internally resets the Write Enable Latch to 0 before the operation completes (the exact timing is not specified).

A Parameter Sector Erase (P4E, P8E) instruction applied to a sector that has been Write Protected through the Block Protect Bits will not be executed.

The Parameter Sector Erase Command (P8E) erases two of the 4 KB Sectors in selected address space. The Parameter Sector Erase Command (P8E) erases two sequential 4 KB Parameter Sectors in the selected address space. The address LSB is disregarded so that two sequential 4 KB Parameter Sectors are erased. The 24 Bit Address is any location within the first Sector to be erased (n), and the next sequential 4 KB Parameter Sector will also be erased (n+1). The 4 KB parameter Sector will only be erased properly if n or n+1 is a valid 4 KB parameter Sector. i.e. If n is not a valid 4K parameter Sector, then it will not be erased. If n+1 is not a valid 4 KB parameter Sector, then it will not be erased.

Note: The P4E and P8E commands do not apply to the uniform 256 KB sector device.

Figure 9.19 Parameter Sector Erase (P4E, P8E) Instruction Sequence

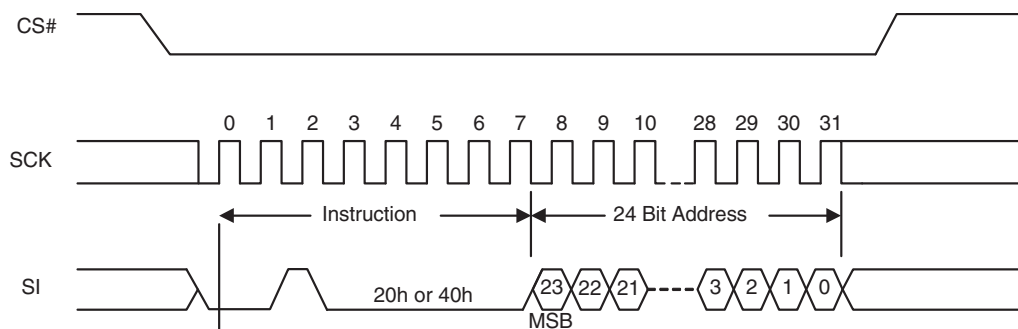

9.17 Sector Erase (SE)

The Sector Erase (SE) command sets all bits at all addresses within a specified sector to a logic 1. A WREN command is required prior to writing the SE command.

The host system must drive CS# low, and then write the SE command plus three address bytes on SI. Any address within the sector (see [Table 7.3 on page 13](#)) is a valid address for the SE command. CS# must be driven low for the entire duration of the SE sequence. The command sequence is shown in [Figure 9.20](#) and [Table 9.1 on page 21](#).

The host system must drive CS# high after the device has latched the 24th bit of the SE address, otherwise the device does not execute the command. The SE operation begins as soon as CS# is driven high. The device internally controls the timing of the operation, which requires a period of t_{SE} . The Status Register may be read to check the value of the Write In Progress (WIP) bit while the SE operation is in progress. The WIP bit is 1 during the SE operation, and is 0 when the operation is completed. The device internally resets the Write Enable Latch to 0 before the operation completes (the exact timing is not specified).

The device only executes a SE command for those sectors which are not protected by the Block Protect bits (BP2:BP0) (see [Table 7.3 on page 13](#)). Otherwise, the device ignores the command.

A 64 KB sector erase (D8h) command issued on 4 KB or 8 KB erase sectors will erase all sectors in the specified 64 KB region. However, please note that a 4 KB sector erase (20h) or 8 KB sector erase (40h) command will not work on a 64 KB sector.

Figure 9.20 Sector Erase (SE) Command Sequence

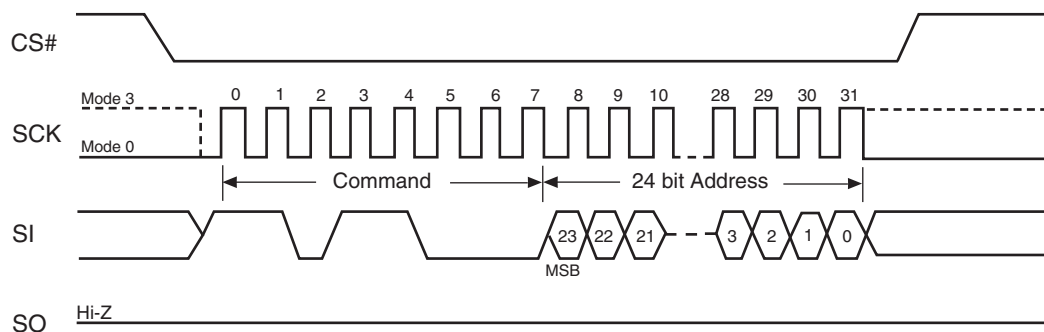

9.18 Bulk Erase (BE)

The Bulk Erase (BE) command sets all the bits within the entire memory array to logic 1s. A WREN command is required prior to writing the BE command.

The host system must drive CS# low, and then write the BE command on SI. CS# must be driven low for the entire duration of the BE sequence. The command sequence is shown in [Figure 9.21](#) and [Table 9.1 on page 21](#).

The host system must drive CS# high after the device has latched the 8th bit of the CE command, otherwise the device does not execute the command. The BE operation begins as soon as CS# is driven high. The device internally controls the timing of the operation, which requires a period of t_{BE} . The Status Register may be read to check the value of the Write In Progress (WIP) bit while the BE operation is in progress. The WIP bit is 1 during the BE operation, and is 0 when the operation is completed. The device internally resets the Write Enable Latch to 0 before the operation completes (the exact timing is not specified).

The device only executes a BE command if all Block Protect bits (BP2:BP0) are 0 (see [Table 7.3 on page 13](#)). Otherwise, the device ignores the command.

Figure 9.21 Bulk Erase (BE) Command Sequence

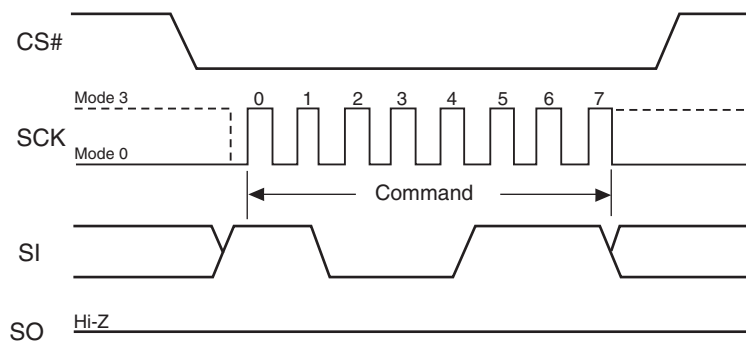

9.19 Deep Power-Down (DP)

The Deep Power-Down (DP) command provides the lowest power consumption mode of the device. It is intended for periods when the device is not in active use, and ignores all commands except for the Release from Deep Power-Down (RES) command. *The DP mode therefore provides the maximum data protection against unintended write operations.* The standard standby mode, which the device goes into automatically when CS# is high (and all operations in progress are complete), should generally be used for the lowest power consumption when the quickest return to device activity is required.

The host system must drive CS# low, and then write the DP command on SI. CS# must be driven low for the entire duration of the DP sequence. The command sequence is shown in [Figure 9.22](#) and [Table 9.1 on page 21](#).

The host system must drive CS# high after the device has latched the 8th bit of the DP command, otherwise the device does not execute the command. After a delay of t_{DP} , the device enters the DP mode and current reduces from I_{SB} to I_{DP} (see [Table 16.1 on page 55](#)).

Once the device has entered the DP mode, all commands are ignored except the RES command (which releases the device from the DP mode). The RES command also provides the Electronic Signature of the device to be output on SO, if desired (see [Section 9.20 and 9.20.1](#)).

DP mode automatically terminates when power is removed, and the device always powers up in the standard standby mode. The device rejects any DP command issued while it is executing a program, erase, or Write Registers operation, and continues the operation uninterrupted.

Figure 9.22 Deep Power-Down (DP) Command Sequence



9.20 Release from Deep Power-Down (RES)

The device requires the Release from Deep Power-Down (RES) command to exit the Deep Power-Down mode. When the device is in the Deep Power-Down mode, all commands except RES are ignored.

The host system must drive CS# low and write the RES command to SI. CS# must be driven low for the entire duration of the sequence. The command sequence is shown in Figure 9.23 and Table 9.1 on page 21.

The host system must drive CS# high $t_{RES(max)}$ after the 8-bit RES command byte. The device transitions from DP mode to the standby mode after a delay of t_{RES} (see Figure 18.1). In the standby mode, the device can execute any read or write command.

Note: The RES command does not reset the Write Enable Latch (WEL) bit.

Figure 9.23 Release from Deep Power-Down (RES) Command Sequence

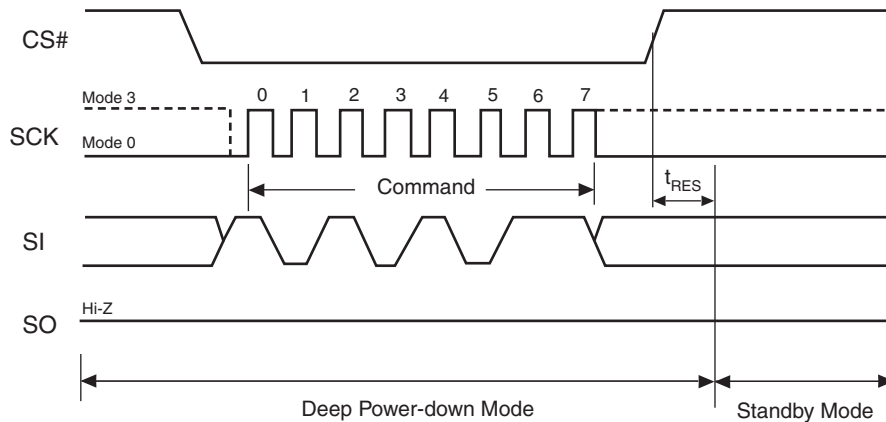

9.20.1 Release from Deep Power-Down and Read Electronic Signature (RES)

The device features an 8-bit Electronic Signature, which can be read using the RES command. See [Figure 9.24](#) and [Table 9.1 on page 21](#) for the command sequence and signature value. The Electronic Signature is not to be confused with the identification data obtained using the RDID command. The device offers the Electronic Signature so that it can be used with previous devices that offered it; however, the Electronic Signature should not be used for new designs, which should read the RDID data instead.

After the host system drives CS# low, it must write the RES command followed by 3 dummy bytes to SI (each bit is latched on SI during the rising edge of SCK). The Electronic Signature is then output on SO; each bit is shifted out on the falling edge of SCK. The RES operation is terminated by driving CS# high after the Electronic Signature is read at least once. Additional clock cycles on SCK with CS# low cause the device to output the Electronic Signature repeatedly.

When CS# is driven high, the device transitions from DP mode to the standby mode after a delay of t_{RES} , as previously described. The RES command always provides access to the Electronic Signature of the device and can be applied even if DP mode has not been entered.

Any RES command issued while an erase, program, or Write Registers operation is in progress not executed, and the operation continues uninterrupted.

Note: The RES command does not reset the Write Enable Latch (WEL) bit.

Figure 9.24 Release from Deep Power-Down and RES Command Sequence



9.21 Clear Status Register (CLSR)

The Clear Status Register command resets bit SR5 (Erase Fail Flag) and bit SR6 (Program Fail Flag). It is not necessary to set the WEL bit before the Clear SR Fail Flags command is executed. The WEL bit will be unchanged after this command is executed.

Figure 9.25 Clear Status Register (CLSR) Instruction Sequence

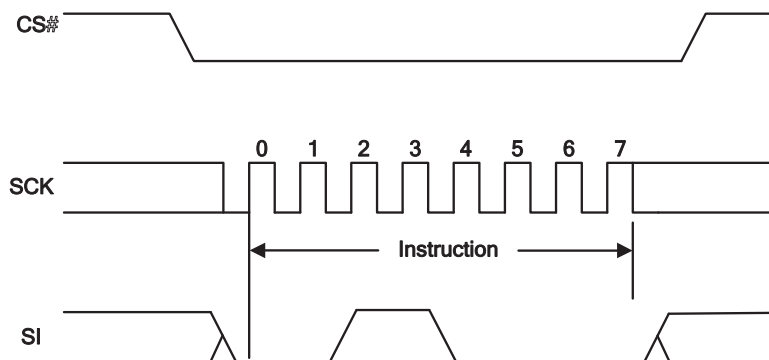

9.22 OTP Program (OTPP)

The OTP Program command programs data in the OTP region, which is in a different address space from the main array data. Refer to *OTP Regions* on page 48 for details on the OTP region. The protocol of the OTP Program command is the same as the Page Program command, except that the OTP Program command requires exactly one byte of data; otherwise, the command will be ignored. To program the OTP in bit granularity, the rest of the bits within the data byte can be set to “1”.

The OTP memory space can be programmed one or more times, provided that the OTP memory space is not locked (as described in “Locking OTP Regions”). Subsequent OTP programming can be performed only on the unprogrammed bits (that is, “1” data).

Note: The Write Enable (WREN) command must precede the OTP command before programming of the OTP can occur.

Figure 9.26 OTP Program Instruction Sequence

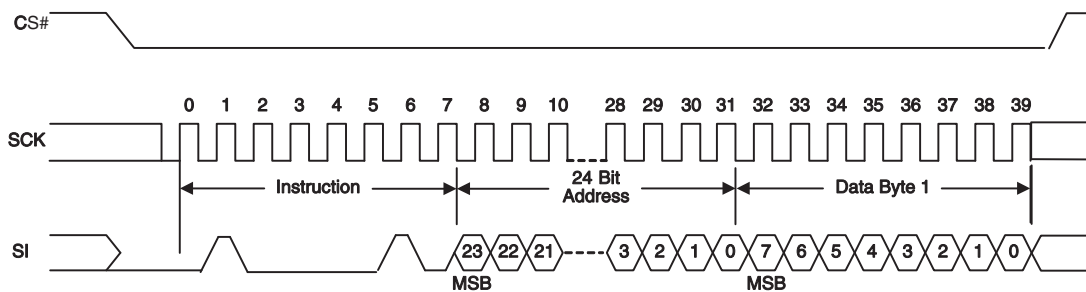

9.23 Read OTP Data Bytes (OTPR)

The Read OTP Data Bytes command reads data from the OTP region. Refer to “*OTP Regions*” for details on the OTP region. The protocol of the Read OTP Data Bytes command is the same as the Fast Read Data Bytes command except that it will not wrap to the starting address after the OTP address is at its maximum; instead, the data will be indeterminate.

Figure 9.27 Read OTP Instruction Sequence

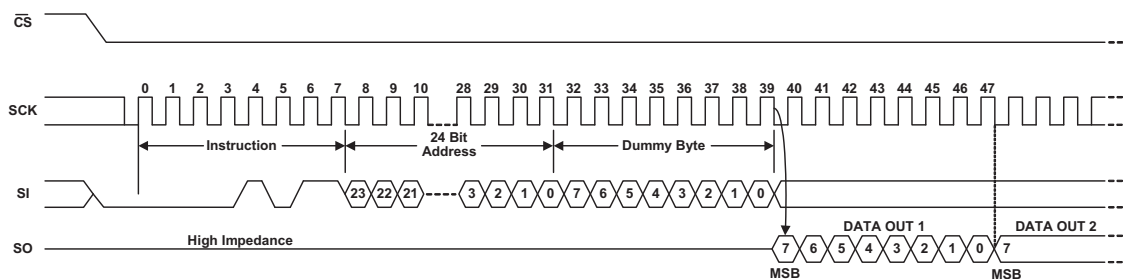

10. OTP Regions

The OTP Regions are separately addressable from the main array and consists of two 8-byte (ESN), thirty 16-byte, and one 10-byte regions that can be individually locked.

- The two 8-byte ESN region is a special order part (please contact your local Cypress sales representative for further details). The two 8-byte regions enable permanent part identification through an Electronic Serial Number (ESN). The customer can utilize the ESN to pair a Flash device with the system CPU/ASIC to prevent system cloning. The Cypress factory programs and locks the lower 8-byte ESN with a 64-bit randomly generated, unique number. The upper 8-byte ESN is left blank for customer use or, if special ordered, Cypress can program (and lock) in a unique customer ID.

	Lock Register ESN1 (Bit 0)	Lock Register ESN2 (Bit 1)	ESN1 Region Contains	ESN2 Region Contains
Standard part	1h	1h	0h	0h
Special order part	1h	1h/0h	Unique random pattern	Factory/Customer programmed pattern

- The thirty 16-byte and one 10-byte OTP regions are open for the customer usage.
- The thirty 16-byte, one 10-byte, and upper 8-byte ESN OTP regions can be individually locked by the end user. Once locked, the data cannot be changed. The locking process is permanent and cannot be undone.

The following general conditions should be noted with respect to the OTP Regions:

- On power-up, or following a hardware reset, or at the end of an OTPP or an OTPR command, the device reverts to sending commands to the normal address space.
- Reads or Programs outside of the OTP Regions will be ignored
- The OTP Region is not accessible when the device is executing an Embedded Program or Embedded Erase algorithm.
- The ACC function is not available when accessing the OTP Regions.
- The thirty 16-byte and one 10-byte OTP regions are left open for customer usage, but special care of the OTP locking must be maintained, or else a malevolent user can permanently lock the OTP regions. This is not a concern, if the OTP regions are not used.

10.1 Programming OTP Address Space

The protocol of the OTP Program command (42h) is the same as the Page Program command. Refer to [Table 9.1](#) for the command description and protocol. The OTP Program command can be issued multiple times to any given OTP address, but this address space can never be erased. After a given OTP region is programmed, it can be locked to prevent further programming with the OTP lock registers (refer to [Section 10.3](#)). The valid address range for OTP Program is depicted in the figure below. OTP Program operations outside the valid OTP address range will be ignored.

10.2 Reading OTP Data

The protocol of the OTP Read command (4Bh) is the same as that of the Fast Read command. Refer to [Table 9.1](#) for the command description and protocol. The valid address range for OTP Reads is depicted in the figure below. OTP Read operations outside the valid OTP address range will yield indeterminate data.

10.3 Locking OTP Regions

In order to permanently lock the ESN and OTP regions, individual bits at the specified addresses can be set to 1 to lock specific regions of OTP memory, as highlighted in [Figures 10.1](#) and [10.2](#).

Figure 10.1 OTP Memory Map - Part 1

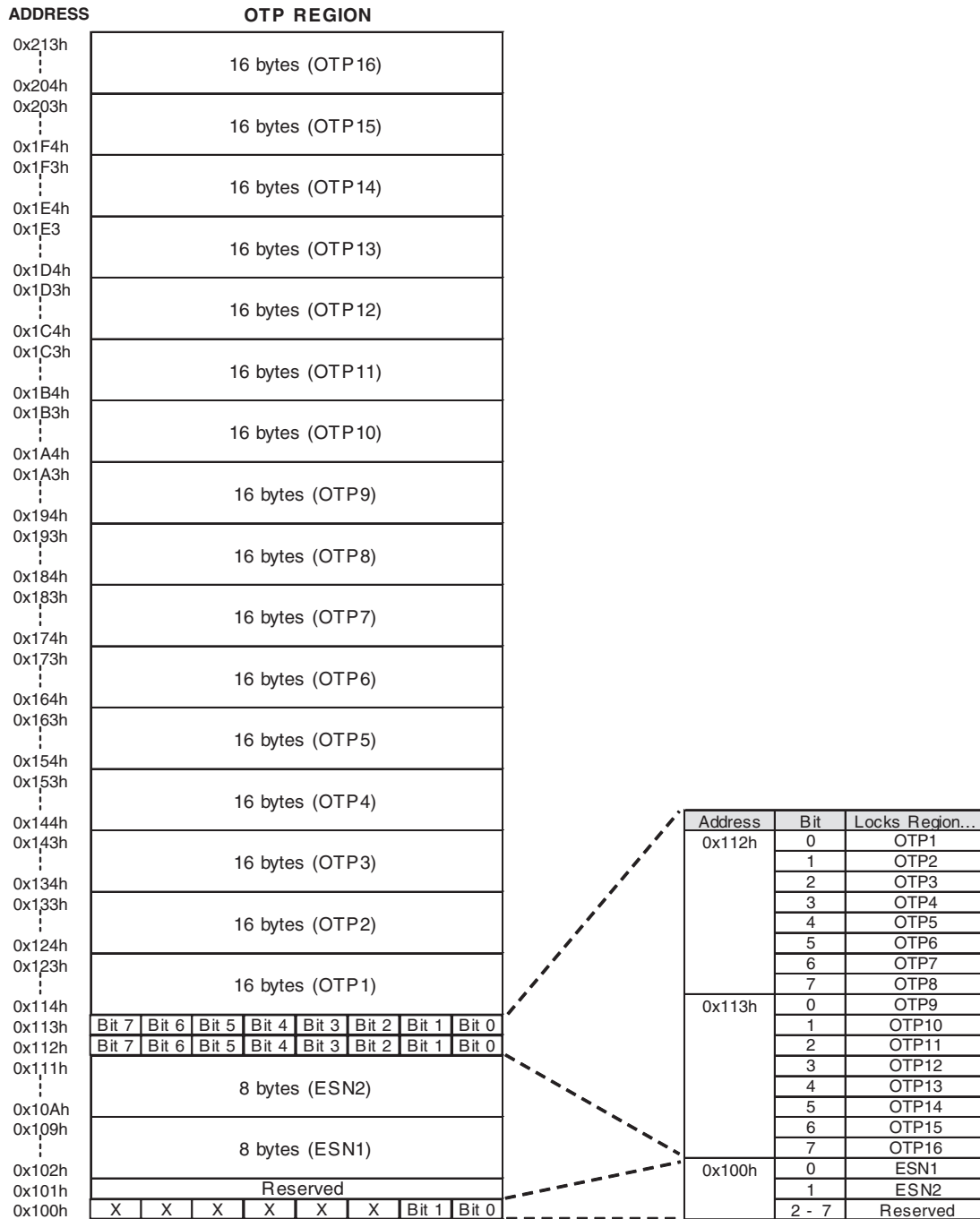

- Notes**
1. Bit 0 at address 0x100h locks ESN1 region.
 2. Bit 1 at address 0x100h locks ESN2 region.
 3. Bits 2-7 ("X") are NOT programmable and will be ignored.

Figure 10.2 OTP Memory Map - Part 2

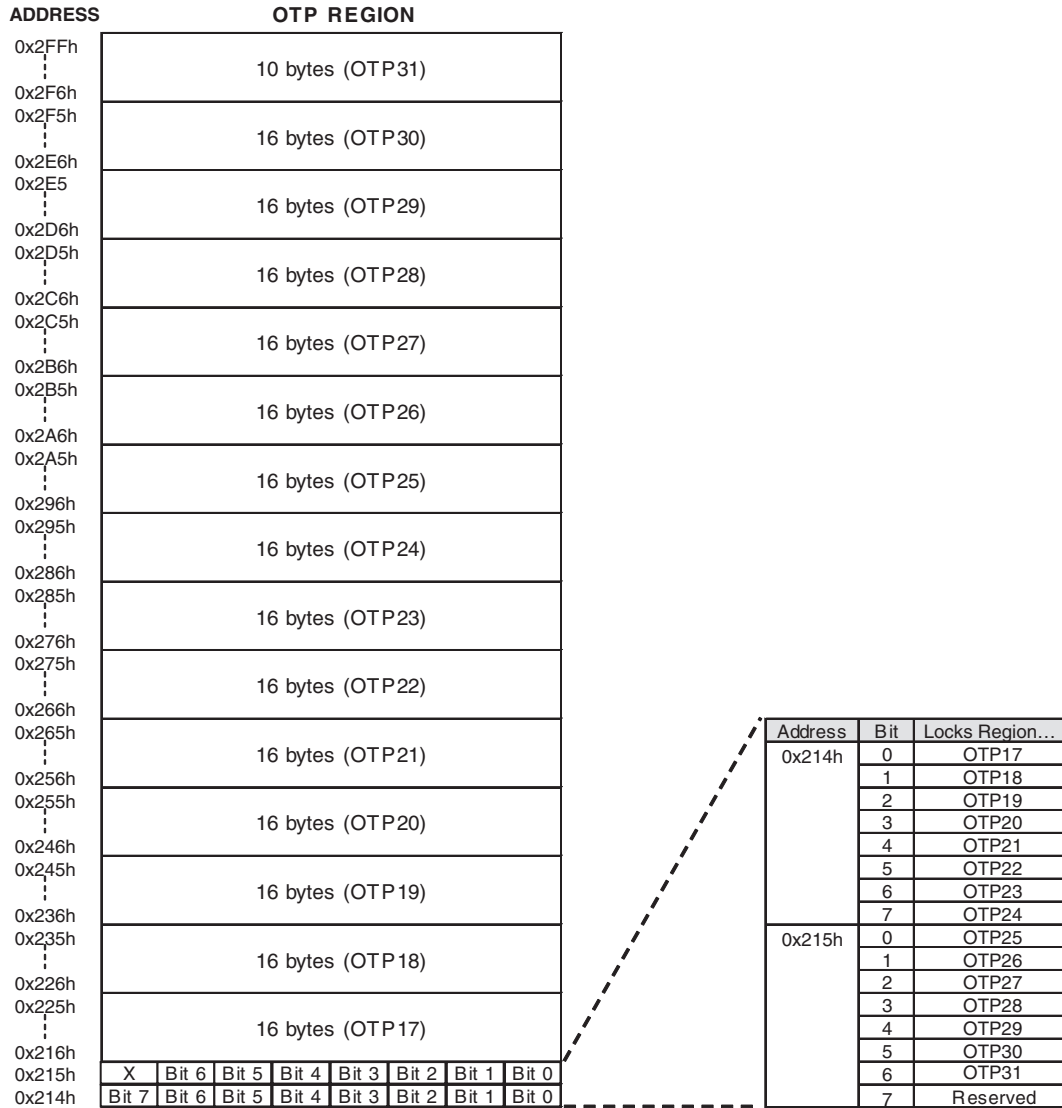

Note
 1. Bit 7 ("X") at address 0x215h is NOT programmable and will be ignored.

11. Power-up and Power-down

During power-up and power-down, certain conditions must be observed. CS# must follow the voltage applied on V_{CC} , and must not be driven low to select the device until V_{CC} reaches the allowable values as follows (see [Figure 11.1](#) and [Table 11.1 on page 52](#)):

- At power-up, V_{CC} (min.) plus a period of t_{PU}
- At power-down, GND

A pull-up resistor on Chip Select (CS#) typically meets proper power-up and power-down requirements.

No Read, Write Registers, program, or erase command should be sent to the device until V_{CC} rises to the V_{CC} min., plus a delay of t_{PU} . At power-up, the device is in standby mode (not Deep Power-Down mode) and the WEL bit is reset (0).

Each device in the host system should have the V_{CC} rail decoupled by a suitable capacitor close to the package pins (this capacitor is generally of the order of 0.1 μF), as a precaution to stabilizing the V_{CC} feed.

When V_{CC} drops from the operating voltage to below the minimum V_{CC} threshold at power-down, all operations are disabled and the device does not respond to any commands. Note that data corruption may result if a power-down occurs while a Write Registers, program, or erase operation is in progress.

Figure 11.1 Power-Up Timing Diagram

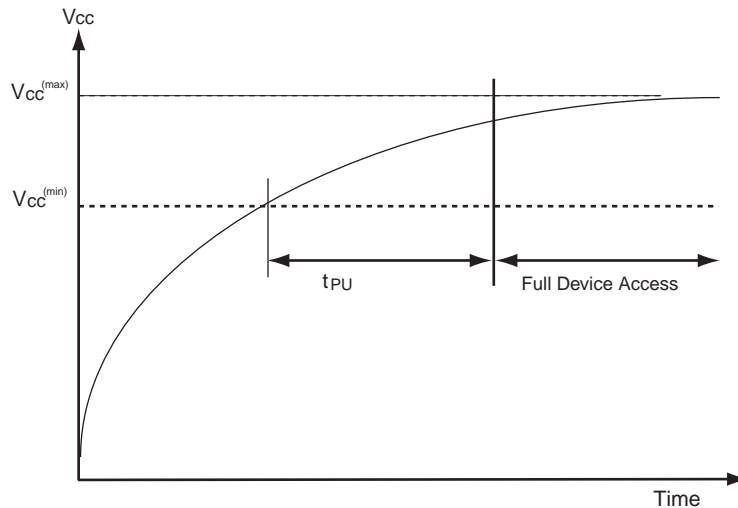

Figure 11.2 Power-down and Voltage Drop

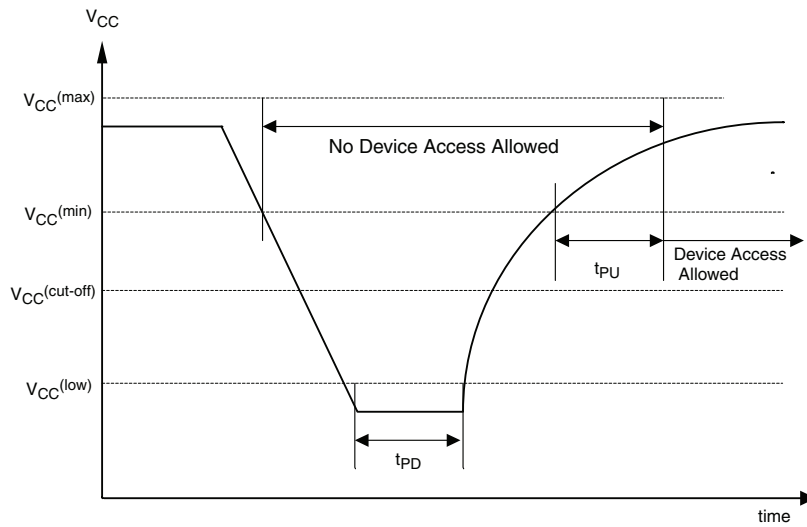

Table 11.1 Power-Up / Power-Down Voltage and Timing

Symbol	Parameter	Min	Max	Unit
$V_{CC(min)}$	V_{CC} (minimum operation voltage)	2.7		V
$V_{CC(cut-off)}$	V_{CC} (Cut off where re-initialization is needed)	2.4		V
$V_{CC(low)}$	V_{CC} (Low voltage for initialization to occur at read/standby) V_{CC} (Low voltage for initialization to occur at embedded)	0.2 2.3		V
t_{PU}	$V_{CC(min.)}$ to device operation	300		μs
T_{PD}	V_{CC} (low duration time)	1.0		μs

12. Initial Delivery State

The device is delivered with the memory array erased i.e. all bits are set to 1 (FFh) upon initial factory shipment. The Status Register and Configuration Register contains 00h (all bits are set to 0).

The Lock Register (address 0x100h) is written to 0x01 and ESN1 (addresses 0x102h-0x109h) are written with a 64-bit randomly generated, unique number (taken from [Section 10. on page 48](#)).

13. Program Acceleration via W#/ACC Pin

The program acceleration function requires applying V_{HH} to the W#/ACC input, and then waiting a period of t_{WC} . Minimum $t_{V_{HH}}$ rise and fall times is required for W#/ACC to change to V_{HH} from V_{IL} or V_{IH} . Removing V_{HH} from the W#/ACC pin returns the device to normal operation after a period of t_{WC} .

Figure 13.1 ACC Program Acceleration Timing Requirements



Note

Only Read Status Register (RDSR) and Page Program (PP) operation are allow when ACC is at (V_{HH}).
The W#/ACC pin is disabled during Quad I/O mode.

Table 13.1 ACC Program Acceleration Specifications

Symbol	Parameter	Min.	Max	Unit
V_{HH}	ACC Pin Voltage High	8.5	9.5	V
t_{VHH}	ACC Voltage Rise and Fall time	2.2		μ s
t_{WC}	ACC at V_{HH} and V_{IL} or V_{IH} to First command	5		μ s

14. Electrical Specifications

14.1 Absolute Maximum Ratings

Description	Rating
Ambient Storage Temperature	-65°C to +150°C
Voltage with Respect to Ground: All Inputs and I/Os	-0.5V to $V_{CC}+0.5V$
Output Short Circuit Current (2)	200 mA

Note

1. Minimum DC voltage on input or I/Os is -0.5V. During voltage transitions, inputs or I/Os may undershoot GND to -2.0V for periods of up to 20 ns. See Figure 14.1.
Maximum DC voltage on input or I/Os is $V_{CC} + 0.5V$. During voltage transitions inputs or I/Os may overshoot to $V_{CC} + 2.0V$ for periods up to 20 ns. See Figure 14.2.
2. No more than one output may be shorted to ground at a time. Duration of the short circuit should not be greater than one second.
3. Stresses above those listed under "Absolute Maximum Ratings" may cause permanent damage to the device. This is a stress rating only; functional operation of the device at these or any other conditions above those indicated in the operational sections of this data sheet is not implied. Exposure of the device to absolute maximum rating conditions for extended periods may affect device reliability.

Figure 14.1 Maximum Negative Overshoot Waveform

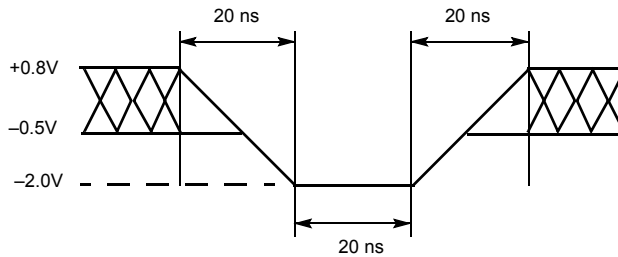
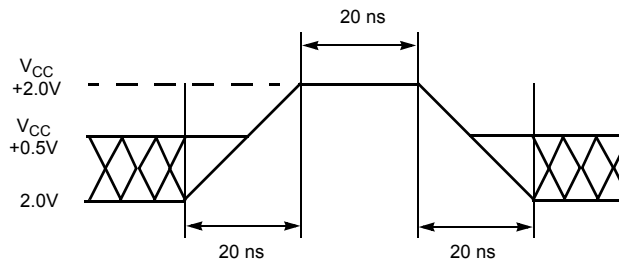

Figure 14.2 Maximum Positive Overshoot Waveform



15. Operating Ranges

Table 15.1 Operating Ranges

Description	Rating	
Ambient Operating Temperature (T_A)	Industrial	-40°C to +85°C
	Automotive In-Cabin	-40°C to +105°C
Positive Power Supply	Voltage Range	2.7V to 3.6V

Note

Operating ranges define those limits between which functionality of the device is guaranteed.

16. DC Characteristics

This section summarizes the DC Characteristics of the device. Designers should check that the operating conditions in their circuit match the measurement conditions specified in the Test Specifications in [Table 17.1 on page 56](#), when relying on the quoted parameters.

Table 16.1 DC Characteristics (CMOS Compatible)

Symbol	Parameter	Test Conditions	Limits			Unit
			Min.	Typ*	Max	
V_{CC}	Supply Voltage		2.7		3.6	V
V_{HH}	ACC Program Acceleration Voltage	$V_{CC} = 2.7V$ to $3.6V$	8.5		9.5	V
V_{IL}	Input Low Voltage		-0.3		$0.3 \times V_{CC}$	V
V_{IH}	Input High Voltage		$0.7 \times V_{CC}$		$V_{CC} + 0.5$	V
V_{OL}	Output Low Voltage	$I_{OL} = 1.6$ mA, $V_{CC} = V_{CC}$ min.			0.4	V
V_{OH}	Output High Voltage	$I_{OH} = -0.1$ mA	$V_{CC} - 0.6$			V
I_{LI}	Input Leakage Current	$V_{CC} = V_{CC}$ Max, $V_{IN} = V_{CC}$ or GND			± 2	μA
I_{LO}	Output Leakage Current	$V_{CC} = V_{CC}$ Max, $V_{IN} = V_{CC}$ or GND			± 2	μA
I_{CC1}	Active Power Supply Current - READ (SO = Open)	At 80 MHz (Dual or Quad)			38	mA
		At 104 MHz (Serial)			25	
		At 40 MHz (Serial)			12	
I_{CC2}	Active Power Supply Current (Page Program)	$CS\# = V_{CC}$			26	mA
I_{CC3}	Active Power Supply Current (WRR)	$CS\# = V_{CC}$			15	mA
I_{CC4}	Active Power Supply Current (SE)	$CS\# = V_{CC}$			26	mA
I_{CC5}	Active Power Supply Current (BE)	$CS\# = V_{CC}$			26	mA
I_{SB1}	Standby Current (Industrial Temperature Range Parts)	$CS\# = V_{CC}$; $SO + V_{IN} = GND$ or V_{CC}		80	200	μA
	Standby Current (Automotive In-Cabin Temperature Range Parts)			80	250	μA
I_{PD}	Deep Power-down Current	$CS\# = V_{CC}$; $SO + V_{IN} = GND$ or V_{CC}		3	10	μA

*Typical values are at $T_{AI} = 25^{\circ}C$ and $V_{CC} = 3V$

17. Test Conditions

Figure 17.1 AC Measurements I/O Waveform



Table 17.1 Test Specifications

Symbol	Parameter	Min	Max	Unit
C_L	Load Capacitance	30		pF
	Input Rise and Fall Times		5	ns
	Input Pulse Voltage	$0.2 V_{CC}$ to $0.8 V_{CC}$		V
	Input Timing Reference Voltage	$0.3 V_{CC}$ to $0.7 V_{CC}$		V
	Output Timing Reference Voltage	$0.5 V_{CC}$		V

18. AC Characteristics

Figure 18.1 AC Characteristics

Symbol (Notes)	Parameter (Notes)	Min. (Notes)	Typ (Notes)	Max (Notes)	Unit
f_R	SCK Clock Frequency for READ command	DC		40	MHz
	SCK Clock Frequency for RDID command	DC		50	MHz
f_C	SCK Clock Frequency for all others: FAST_READ, PP, QPP, P4E, P8E, SE, BE, DP, RES, WREN, WRDI, RDSR, WRR, READ_ID	DC		104 (serial) 80 (dual/quad)	MHz
t_{WH}, t_{CH} (5)	Clock High Time	4.5			ns
t_{WL}, t_{CL} (5)	Clock Low Time	4.5			ns
t_{CRT}, t_{CLCH}	Clock Rise Time (slew rate)	0.1			V/ns
t_{CFT}, t_{CHCL}	Clock Fall Time (slew rate)	0.1			V/ns
t_{CS}	CS# High Time (Read Instructions)	10			ns
	CS# High Time (Program/Erase)	50			
t_{CSS}	CS# Active Setup Time (relative to SCK)	3			ns
t_{CSH}	CS# Active Hold Time (relative to SCK)	3			ns
$t_{SU:DAT}$	Data in Setup Time	3			ns
$t_{HD:DAT}$	Data in Hold Time	2			ns
t_V	Clock Low to Output Valid	0		8 (Serial) Δ 9.5 (Dual/Quad) Δ 6.5 (Serial) ∞ 8 (Dual/Quad) ∞ 7 (Dual/Quad) Ω	ns
t_{HO}	Output Hold Time	2			ns
t_{DIS}	Output Disable Time			8	ns
t_{HLCH}	HOLD# Active Setup Time (relative to SCK)	3			ns
t_{CHHH}	HOLD# Active Hold Time (relative to SCK)	3			ns
t_{HHCH}	HOLD# Non Active Setup Time (relative to SCK)	3			ns
t_{CHHL}	HOLD# Non Active Hold Time (relative to SCK)	3			ns
t_{HZ}	HOLD# enable to Output Invalid			8	ns
t_{LZ}	HOLD# disable to Output Valid			8	ns
t_{WPS}	W#/ACC Setup Time (4)	20			ns
t_{WPH}	W#/ACC Hold Time (4)	100			ns
t_W	WRR Cycle Time			50	ms
t_{PP}	Page Programming (1)(2)		1.5	3	ms
t_{EP}	Page Programming (ACC = 9V) (1)(2)(3)		1.2	2.4	ms
t_{SE}	Sector Erase Time (64 KB) (1)(2)		0.5	2	sec
	Sector Erase Time (256 KB) (1)(2)		2	8	sec
t_{PE}	Parameter Sector Erase Time (4 KB or 8 KB) (1)(2)		200	800	ms
t_{BE}	Bulk Erase Time (1)(2)		128	256	sec
t_{RES}	Deep Power-down to Standby Mode			30	μ s
t_{DP}	Time to enter Deep Power-down Mode			10	μ s
t_{VHH}	ACC Voltage Rise and Fall time	2.2			μ s
t_{WC}	ACC at VHH and VIL or VIH to first command	5			μ s

Notes

1. Typical program and erase times assume the following conditions: 25°C, VCC = 3.0V; 10,000 cycles; checkerboard data pattern.
2. Under worst-case conditions of 85°C; VCC = 2.7V; 100,000 cycles.
3. Acceleration mode (9V ACC) only in Program mode, not Erase.
4. Only applicable as a constraint for WRR instruction when SRWD is set to a '1'.

5. $t_{WH} + t_{WL}$ must be less than or equal to $1/f_C$.
6. Δ Full Vcc range (2.7 – 3.6V) and $CL = 30$ pF
7. ∞ Regulated Vcc range (3.0 – 3.6V) and $CL = 30$ pF
8. Ω Regulated Vcc range (3.0 – 3.6V) and $CL = 15$ pF

18.1 Capacitance

Symbol	Parameter	Test Conditions	Min	Typ	Max	Unit
C_{IN}	Input Capacitance (applies to SCK, PO7-PO0, SI, CS#)	$V_{OUT} = 0V$		9.0	12.0	pF
C_{OUT}	Output Capacitance (applies to PO7-PO0, SO)	$V_{IN} = 0V$		12.0	16.0	pF

Figure 18.2 SPI Mode 0 (0,0) Input Timing

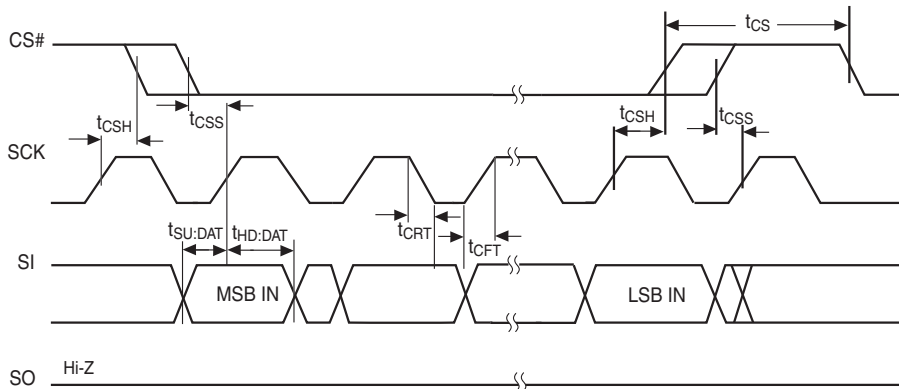

Figure 18.3 SPI Mode 0 (0,0) Output Timing

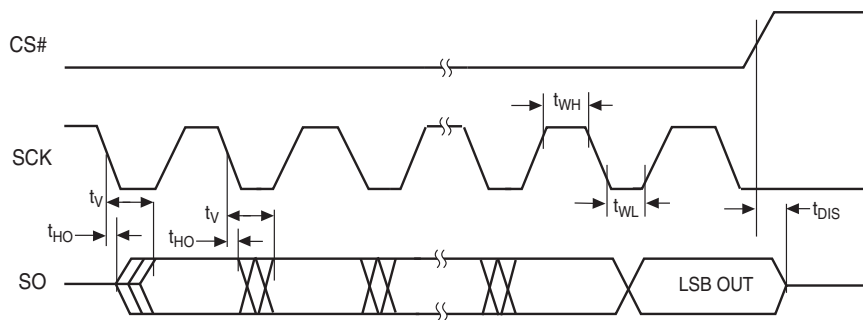

Figure 18.4 HOLD# Timing

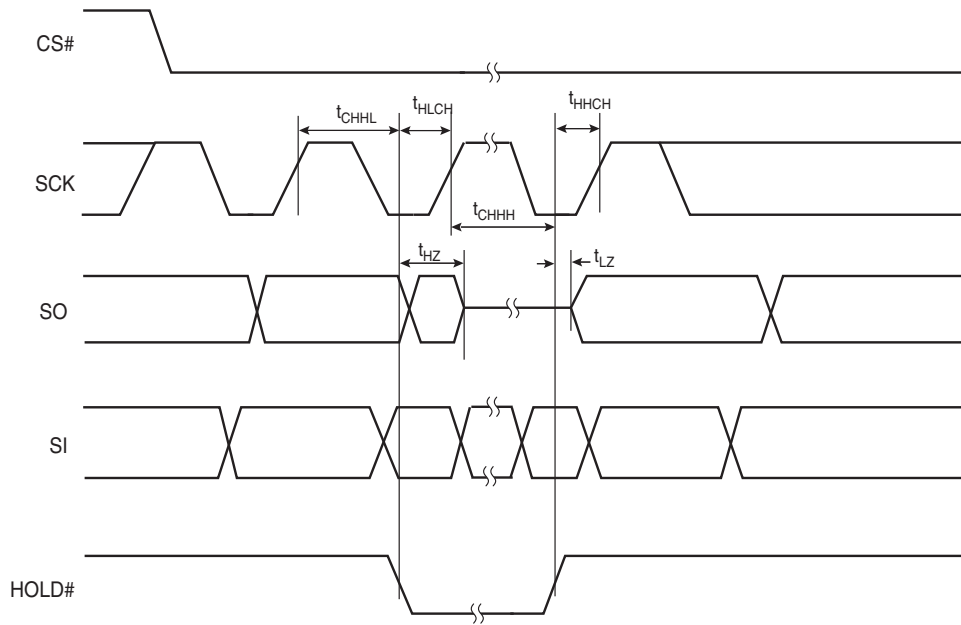
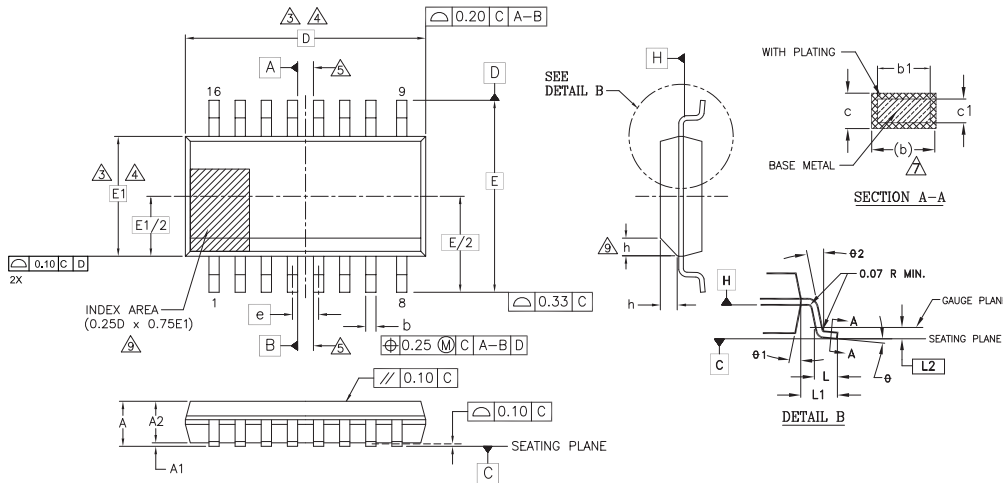

Figure 18.5 Write Protect Setup and Hold Timing during WRR when SRWD = 1









19. Physical Dimensions

19.1 SO3 016 — 16-pin Wide Plastic Small Outline Package (300-mil Body Width)



PACKAGE	SO3 016 (inches)		SO3 016 (mm)	
JEDEC	MS-013(E)AA		MS-013(E)AA	
SYMBOL	MIN	MAX	MIN	MAX
A	0.093	0.104	2.35	2.65
A1	0.004	0.012	0.10	0.30
A2	0.081	0.104	2.05	2.55
b	0.012	0.020	0.31	0.51
b1	0.011	0.019	0.27	0.48
c	0.008	0.013	0.20	0.33
c1	0.008	0.012	0.20	0.30
D	0.406 BSC		10.30 BSC	
E	0.406 BSC		10.30 BSC	
E1	0.295 BSC		7.50 BSC	
e	0.050 BSC		1.27 BSC	
L	0.016	0.050	0.40	1.27
L1	0.055 REF		1.40 REF	
L2	0.010 BSC		0.25 BSC	
N	16		16	
h	0.10	0.30	0.25	0.75
theta	0°	8°	0°	8°
theta1	5°	15°	5°	15°
theta2	0°	—	0°	—

NOTES:

- ALL DIMENSIONS ARE IN BOTH INCHES AND MILLIMETERS.
- DIMENSIONING AND TOLERANCING PER ASME Y14.5M - 1994.
-  DIMENSION D DOES NOT INCLUDE MOLD FLASH, PROTRUSIONS OR GATE BURRS. MOLD FLASH, PROTRUSIONS OR GATE BURRS SHALL NOT EXCEED 0.15 mm PER END. DIMENSION E1 DOES NOT INCLUDE INTERLEAD FLASH OR PROTRUSION INTERLEAD FLASH OR PROTRUSION SHALL NOT EXCEED 0.25 mm PER SIDE. D AND E1 DIMENSIONS ARE DETERMINED AT DATUM H.
-  THE PACKAGE TOP MAY BE SMALLER THAN THE PACKAGE BOTTOM. DIMENSIONS D AND E1 ARE DETERMINED AT THE OUTMOST EXTREMES OF THE PLASTIC BODY EXCLUSIVE OF MOLD FLASH, TIE BAR BURRS, GATE BURRS AND INTERLEAD FLASH. BUT INCLUDING ANY MISMATCH BETWEEN THE TOP AND BOTTOM OF THE PLASTIC BODY.
-  DATUMS A AND B TO BE DETERMINED AT DATUM H.
- "N" IS THE MAXIMUM NUMBER OF TERMINAL POSITIONS FOR THE SPECIFIED PACKAGE LENGTH.
-  THE DIMENSIONS APPLY TO THE FLAT SECTION OF THE LEAD BETWEEN 0.10 TO 0.25 mm FROM THE LEAD TIP.
-  DIMENSION "b" DOES NOT INCLUDE DAMBAR PROTRUSION. ALLOWABLE DAMBAR PROTRUSION SHALL BE 0.10 mm TOTAL IN EXCESS OF THE "b" DIMENSION AT MAXIMUM MATERIAL CONDITION. THE DAMBAR CANNOT BE LOCATED ON THE LOWER RADIUS OF THE LEAD FOOT.
-  THIS CHAMFER FEATURE IS OPTIONAL. IF IT IS NOT PRESENT, THEN A PIN 1 IDENTIFIER MUST BE LOCATED WITHIN THE INDEX AREA INDICATED.
- LEAD COPLANARITY SHALL BE WITHIN 0.10 mm AS MEASURED FROM THE SEATING PLANE.

g1011/2-16-038.3 /4.1.11

19.2 WSON 8-contact (6 x 8 mm) No-Lead Package (WNF008)



PACKAGE	WNF008			
SYMBOL	MIN	NOM	MAX	NOTE
e	1.27 BSC.			
N	8			3
ND	4			5
L	0.45	0.50	0.55	
b	0.35	0.40	0.45	4
D2	4.70	4.80	4.90	
E2	5.70	5.80	5.90	
D	6.00 BSC			
E	8.00 BSC			
A	0.70	0.75	0.80	
A1	0.00	0.02	0.05	
K	0.20 MIN.			
L1	0.00	---	0.15	10

NOTES:

- DIMENSIONING AND TOLERANCING CONFORMS TO ASME Y14.5M - 1994.
- ALL DIMENSIONS ARE IN MILLIMETERS.
- N IS THE TOTAL NUMBER OF TERMINALS.
- DIMENSION "b" APPLIES TO METALLIZED TERMINAL AND IS MEASURED BETWEEN 0.15 AND 0.30mm FROM TERMINAL TIP. IF THE TERMINAL HAS THE OPTIONAL RADIUS ON THE OTHER END OF THE TERMINAL, THE DIMENSION "b" SHOULD NOT BE MEASURED IN THAT RADIUS AREA.
- ND REFER TO THE NUMBER OF TERMINALS ON D SIDE.
- MAX. PACKAGE WARPAGE IS 0.05mm.
- MAXIMUM ALLOWABLE BURRS IS 0.076mm IN ALL DIRECTIONS.
- PIN #1 ID ON TOP WILL BE LASER MARKED.
- BILATERAL COPLANARITY ZONE APPLIES TO THE EXPOSED HEAT SINK SLUG AS WELL AS THE TERMINALS.
- A MAXIMUM 0.15mm PULL BACK (L1) MAY BE PRESENT.

g1015 \ 16-038.30 \ 07.21.11

19.3 FAB024 — 24-ball Ball Grid Array (6 x 8 mm) package

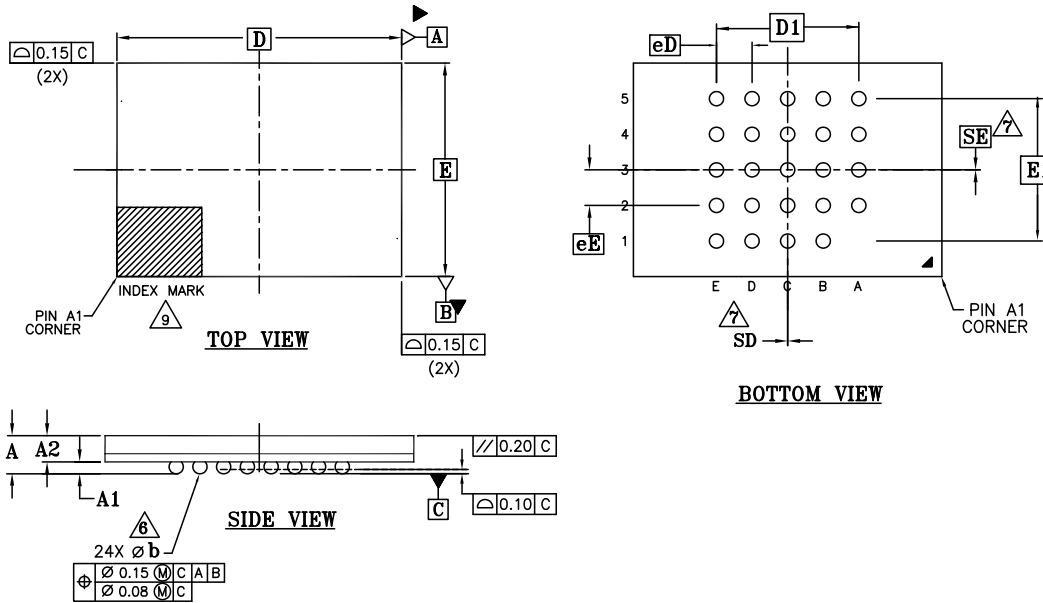

NOTES:

1. DIMENSIONING AND TOLERANCING METHODS PER ASME Y14.5M-1994.
2. ALL DIMENSIONS ARE IN MILLIMETERS.
3. BALL POSITION DESIGNATION PER JEP95, SECTION 4.3, SPP-010.
4. [e] REPRESENTS THE SOLDER BALL GRID PITCH.
5. SYMBOL "MD" IS THE BALL MATRIX SIZE IN THE "D" DIRECTION. SYMBOL "ME" IS THE BALL MATRIX SIZE IN THE "E" DIRECTION. n IS THE NUMBER OF POPULATED SOLDER BALL POSITIONS FOR MATRIX SIZE MD X ME.
6. DIMENSION "b" IS MEASURED AT THE MAXIMUM BALL DIAMETER IN A PLANE PARALLEL TO DATUM C.
7. SD AND SE ARE MEASURED WITH RESPECT TO DATUMS A AND B AND DEFINE THE POSITION OF THE CENTER SOLDER BALL IN THE OUTER ROW.
 WHEN THERE IS AN ODD NUMBER OF SOLDER BALLS IN THE OUTER ROW SD OR SE = 0.000.
 WHEN THERE IS AN EVEN NUMBER OF SOLDER BALLS IN THE OUTER ROW, SD OR SE = $\frac{e}{2}$
8. "+" INDICATES THE THEORETICAL CENTER OF DEPOPULATED BALLS.
9. A1 CORNER TO BE IDENTIFIED BY CHAMFER, LASER OR INK MARK, METALLIZED MARK INDENTATION OR OTHER MEANS.

PACKAGE	FAB024			
JEDEC	N/A			
	8.00mmx6.00mm NOM PACKAGE			
SYMBOL	MIN.	NOM.	MAX.	NOTE
A	-	-	1.20	OVERALL THICKNESS
A1	0.20	-	-	BALL HEIGHT
A2	0.70	-	0.90	BODY THICKNESS
D	8.00 BSC.			BODY SIZE
E	6.00 BSC.			BODY SIZE
[D1]	4.00 BSC.			BALL FOOTPRINT
[E1]	4.00 BSC.			BALL FOOTPRINT
MD	5			ROW MATRIX SIZE D DIRECTION
ME	5			ROW MATRIX SIZE E DIRECTION
N	24			TOTAL BALL COUNT
#b	0.35	0.40	0.45	BALL DIAMETER
[#]	1.00 BSC.			BALL PITCH
SD/SE	0.00			SOLDER BALL PLACEMENT
	A1			DEPOPULATED SOLDER BALLS
	I			PACKAGE OUTLINE TYPE

4002/F16-038 Rev.A /6.04.09

19.4 FAC024 — 24-ball Ball Grid Array (6 x 8 mm) package

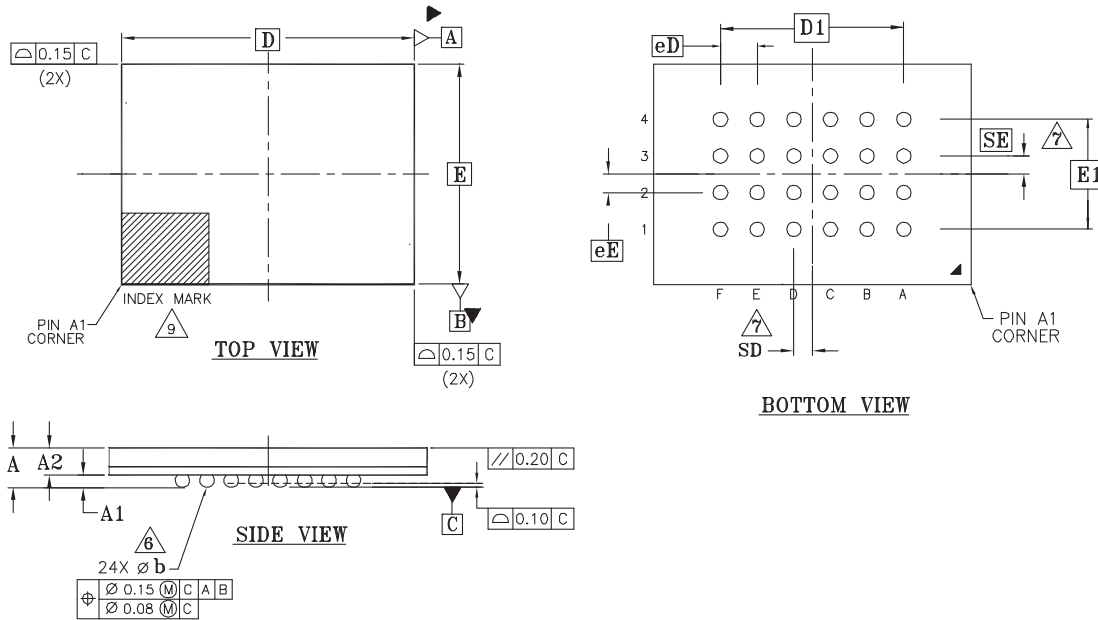

PACKAGE	FAC024			NOTE
JEDEC	N/A			
D x E	8.00 mm x 6.00 mm NOM PACKAGE			
SYMBOL	MIN	NOM	MAX	NOTE
A	---	---	1.20	PROFILE
A1	0.25	---	---	BALL HEIGHT
A2	0.70	---	0.90	BODY THICKNESS
D	8.00 BSC.			BODY SIZE
E	6.00 BSC.			BODY SIZE
D1	5.00 BSC.			MATRIX FOOTPRINT
E1	3.00 BSC.			MATRIX FOOTPRINT
MD	6			MATRIX SIZE D DIRECTION
ME	4			MATRIX SIZE E DIRECTION
N	24			BALL COUNT
øb	0.35	0.40	0.45	BALL DIAMETER
e	1.00 BSC.			BALL PITCH
SD/SE	0.5/0.5			SOLDER BALL PLACEMENT
				DEPOPULATED SOLDER BALLS
	J			PACKAGE OUTLINE TYPE

NOTES:

- DIMENSIONING AND TOLERANCING METHODS PER ASME Y14.5M-1994.
- ALL DIMENSIONS ARE IN MILLIMETERS.
- BALL POSITION DESIGNATION PER JEP95, SECTION 4.3, SPP-010.
- e REPRESENTS THE SOLDER BALL GRID PITCH.
- SYMBOL "MD" IS THE BALL MATRIX SIZE IN THE "D" DIRECTION.
SYMBOL "ME" IS THE BALL MATRIX SIZE IN THE "E" DIRECTION.
n IS THE NUMBER OF POPULATED SOLDER BALL POSITIONS FOR MATRIX SIZE MD X ME.
- DIMENSION "b" IS MEASURED AT THE MAXIMUM BALL DIAMETER IN A PLANE PARALLEL TO DATUM C.
DATUM C IS THE SEATING PLANE AND IS DEFINED BY THE CROWNS OF THE SOLDER BALLS.
- SD AND SE ARE MEASURED WITH RESPECT TO DATUMS A AND B AND DEFINE THE POSITION OF THE CENTER SOLDER BALL IN THE OUTER ROW.
WHEN THERE IS AN ODD NUMBER OF SOLDER BALLS IN THE OUTER ROW SD OR SE = 0.000.
WHEN THERE IS AN EVEN NUMBER OF SOLDER BALLS IN THE OUTER ROW, SD OR SE = $e/2$
- "+" INDICATES THE THEORETICAL CENTER OF DEPOPULATED BALLS.
- A1 CORNER TO BE IDENTIFIED BY CHAMFER, LASER OR INK MARK, METALLIZED MARK INDENTATION OR OTHER MEANS.
- OUTLINE AND DIMENSIONS PER CUSTOMER REQUIREMENT.

3642 F16-038.9 \ 09.10.09

20. Revision History

Spanion Publication Number: S25FL129P_00_09

Document History Page

Document Title: S25FL129P, 128-Mbit 3.0 V Flash Memory Document Number: 002-00648				
Rev.	ECN No.	Orig. of Change	Submission Date	Description of Change
**	–	–	May 26, 2009	Initial release.
*A	–	–	June 22, 2009	<p>Quad Page Programming: Corrected description.</p> <p>Configuration Register: Removed the Note in the bottom of the page. Added Suggested cross setting table.</p> <p>Data Protection Modes: Corrected description for Software Protected Mode.</p> <p>Accelerated Programming Operation: Added Note.</p> <p>Read Identification (RDID) Corrected description.</p> <p>Added statement for operating clock frequency. Corrected figure.</p> <p>Read Status Register (RDSR): Added statement for operating clock frequency.</p> <p>Read Configuration Register (RCR): Added reference section.</p> <p>Write Registers (WRR): Added Note for Hardware Protect Mode.</p> <p>Removed all occurrences of Quad operations.</p> <p>Parameter Sector Erase (P4E, P8E): Corrected description. Added Note.</p> <p>Sector Erase (SE): Corrected description.</p> <p>Release from Deep Power-down (RES): Added Note.</p> <p>Release from Deep Power-down and Read Electronic Signature (RES): Added Note.</p> <p>OTP Regions: Corrected description for ESN. Added ESN table.</p> <p>Initial Delivery State: Added description for the Rock Register.</p> <p>AC Characteristics: Corrected description of Note.</p> <p>Physical Dimensions: Added BGA package.</p>
*B	–	–	October 14, 2009	<p>Global: Changed datasheet designation from Advanced Information to Preliminary</p> <p>Changed all references to RDID clock rate from 40 to 50 MHz</p> <p>Connection Diagrams: Added note regarding exposed central pad on bottom of package to the WSON connection diagram. Added "5 x 5 pin configuration" to Figure 2.3 title. Added 6 x 4 pin configuration BGA connection diagram</p> <p>Ordering Information: Added 20, 21, 30, and 31 model numbers for BGA packages. Added Automotive In-Cabin temperature ordering option. Added Low-Halogen material option</p> <p>Valid Combinations: Changed valid BGA model number combinations to 20, 21, 30, and 31. Changed valid BGA material option to Low-Halogen. Added Automotive In-Cabin temperature valid combinations for all packages. Added Note 2 regarding contact factory for availability of Automotive In-Cabin temperature grade parts</p> <p>Physical Dimensions: Added FAC024 BGA package</p> <p>DC Characteristics: Added Note 1 indicating that ICSB1 maximum value only applies to Industrial temperature grade parts</p> <p>AC Characteristics: Added min and max values for Sector Erase Time (256 KB)</p>
*C	–	–	November 2, 2009	<p>Ordering Information: Removed Note 2</p> <p>DC Characteristics: Added separate Standby Current values for Industrial and Automotive In-Cabin temperature range parts.</p> <p>Removed Note 1.</p>

Document History Page (Continued)

Document Title: S25FL129P, 128-Mbit 3.0 V Flash Memory Document Number: 002-00648				
Rev.	ECN No.	Orig. of Change	Submission Date	Description of Change
*D	–	–	August 12, 2010	Global: The data sheet went from a “Preliminary” designation to full production. Sector Address Table: In Table 8.2, corrected the End Address of SS30 from 01E000h to 01EFFFh. Command Definitions: In Table 9.1, corrected the QIOR one byte command code from 1110 1111 to 1110 1011. Read Identification: In Table 9.5 added CFI data of bytes 2Dh to 34h for the 256 KB sector products. Sector Erase: Clarified that the device only executes a SE command for those sectors which are not protected by the Block Protect Bits. Operating Ranges: Added the Automotive In-Cabin range.
*E	–	–	October 1, 2010	Configuration Register: Clarified that TBPARM and TBPROT must be selected at the initial configuration of the device, before any program or erase operations. Command Definitions: In the Instruction Set table, corrected the CLSR Data Byte Cycle value from 1 to 0. Sector Erase (SE): Clarified that a 64 KB sector erase command will work on 4 KB and 8 KB sectors. Clear Status Register: Removed incomplete statement regarding internal state machine. OTP Regions: Clarified that for locking OTP regions, setting the bit refers to changing the value from 0 to 1.
*F	–	–	May 16, 2012	Added text for recommending FL128S as migration device.
*G	–	–	September 21, 2012	AC Characteristics: Changed Output Hold Time (tHO) to 2 ns (min). Physical Dimensions: Updated the package outline drawing for SO3016 and WSON 6x8 packages.
*H	–	–	January 30, 2013	Capacitance: Added “Typical” values column. Corrected “Max” values for CIN / COUT (Input / Output Capacitance)
*I	4925992	BWHA	September 18, 2015	Updated to Cypress template
*J	5967710	AESATMP8	November 15, 2017	Updated logo and Copyright.

Sales, Solutions, and Legal Information

Worldwide Sales and Design Support

Cypress maintains a worldwide network of offices, solution centers, manufacturer's representatives, and distributors. To find the office closest to you, visit us at [Cypress Locations](#).

Products

ARM® Cortex® Microcontrollers	cypress.com/arm
Automotive	cypress.com/automotive
Clocks & Buffers	cypress.com/clocks
Interface	cypress.com/interface
Internet of Things	cypress.com/iot
Memory	cypress.com/memory
Microcontrollers	cypress.com/mcu
PSoC	cypress.com/psoc
Power Management ICs	cypress.com/pmic
Touch Sensing	cypress.com/touch
USB Controllers	cypress.com/usb
Wireless Connectivity	cypress.com/wireless

PSoC® Solutions

[PSoC 1](#) | [PSoC 3](#) | [PSoC 4](#) | [PSoC 5LP](#) | [PSoC 6](#)

Cypress Developer Community

[Forums](#) | [WICED IOT Forums](#) | [Projects](#) | [Video](#) | [Blogs](#) | [Training](#) | [Components](#)

Technical Support

cypress.com/support

© Cypress Semiconductor Corporation, 2009-2017. This document is the property of Cypress Semiconductor Corporation and its subsidiaries, including Spansion LLC ("Cypress"). This document, including any software or firmware included or referenced in this document ("Software"), is owned by Cypress under the intellectual property laws and treaties of the United States and other countries worldwide. Cypress reserves all rights under such laws and treaties and does not, except as specifically stated in this paragraph, grant any license under its patents, copyrights, trademarks, or other intellectual property rights. If the Software is not accompanied by a license agreement and you do not otherwise have a written agreement with Cypress governing the use of the Software, then Cypress hereby grants you a personal, non-exclusive, nontransferable license (without the right to sublicense) (1) under its copyright rights in the Software (a) for Software provided in source code form, to modify and reproduce the Software solely for use with Cypress hardware products, only internally within your organization, and (b) to distribute the Software in binary code form externally to end users (either directly or indirectly through resellers and distributors), solely for use on Cypress hardware product units, and (2) under those claims of Cypress's patents that are infringed by the Software (as provided by Cypress, unmodified) to make, use, distribute, and import the Software solely for use with Cypress hardware products. Any other use, reproduction, modification, translation, or compilation of the Software is prohibited.

TO THE EXTENT PERMITTED BY APPLICABLE LAW, CYPRESS MAKES NO WARRANTY OF ANY KIND, EXPRESS OR IMPLIED, WITH REGARD TO THIS DOCUMENT OR ANY SOFTWARE OR ACCOMPANYING HARDWARE, INCLUDING, BUT NOT LIMITED TO, THE IMPLIED WARRANTIES OF MERCHANTABILITY AND FITNESS FOR A PARTICULAR PURPOSE. To the extent permitted by applicable law, Cypress reserves the right to make changes to this document without further notice. Cypress does not assume any liability arising out of the application or use of any product or circuit described in this document. Any information provided in this document, including any sample design information or programming code, is provided only for reference purposes. It is the responsibility of the user of this document to properly design, program, and test the functionality and safety of any application made of this information and any resulting product. Cypress products are not designed, intended, or authorized for use as critical components in systems designed or intended for the operation of weapons, weapons systems, nuclear installations, life-support devices or systems, other medical devices or systems (including resuscitation equipment and surgical implants), pollution control or hazardous substances management, or other uses where the failure of the device or system could cause personal injury, death, or property damage ("Unintended Uses"). A critical component is any component of a device or system whose failure to perform can be reasonably expected to cause the failure of the device or system, or to affect its safety or effectiveness. Cypress is not liable, in whole or in part, and you shall and hereby do release Cypress from any claim, damage, or other liability arising from or related to all Unintended Uses of Cypress products. You shall indemnify and hold Cypress harmless from and against all claims, costs, damages, and other liabilities, including claims for personal injury or death, arising from or related to any Unintended Uses of Cypress products.

Cypress, the Cypress logo, Spansion, the Spansion logo, and combinations thereof, WICED, PSoC, CapSense, EZ-USB, F-RAM, and Traveo are trademarks or registered trademarks of Cypress in the United States and other countries. For a more complete list of Cypress trademarks, visit cypress.com. Other names and brands may be claimed as property of their respective owners.

Looking for pricing, stock, or lifecycle information?

Click below to explore more details on WIN SOURCE:

- ⊖ [View S25FL129P0XBHI303 on WIN SOURCE](#)
- ⊖ [Cypress Semiconductor Corp Information](#)

Optimize Your Supply Chain with WIN SOURCE Solutions

- ✓ Global Sourcing Solution
- ✓ Obsolete Management
- ✓ Cost Control Management
- ✓ Shortage Management
- ✓ Alternative Solution
- ✓ Excess Inventory Management