



**THE DATASHEET OF
CY7C199D-10VXIT**



Features

- Temperature range
 - -40 °C to 85 °C
- Pin and function compatible with CY7C199C
- High speed
 - $t_{AA} = 10$ ns
- Low active power
 - $I_{CC} = 80$ mA at 10 ns
- Low CMOS standby power
 - $I_{SB2} = 3$ mA
- 2.0 V data retention
- Automatic power-down when deselected
- Complementary metal oxide semiconductor (CMOS) for optimum speed/power
- Transistor-transistor logic (TTL) compatible inputs and outputs
- Easy memory expansion with \overline{CE} and \overline{OE} features
- Available in Pb-free 28-pin 300-Mil-wide molded small outline J-lead package (SOJ) and 28-pin thin small outline package (TSOP) I packages

Functional Description

The CY7C199D is a high performance CMOS static RAM organized as 32,768 words by 8-bits. Easy memory expansion is provided by an active LOW chip enable (\overline{CE}), an active LOW output enable (\overline{OE}) and tri-state drivers. This device has an automatic power-down feature, reducing the power consumption when deselected. The input and output pins (I/O_0 through I/O_7) are placed in a high impedance state when the device is deselected (\overline{CE} HIGH), the outputs are disabled (\overline{OE} HIGH), or during a write operation (\overline{CE} LOW and \overline{WE} LOW).

Write to the device by taking chip enable (\overline{CE}) and write enable (\overline{WE}) inputs LOW. Data on the eight I/O pins (I/O_0 through I/O_7) is then written into the location specified on the address pins (A_0 through A_{14}).

Read from the device by taking chip enable (\overline{CE}) and output enable (\overline{OE}) LOW while forcing write enable (\overline{WE}) HIGH. Under these conditions, the contents of the memory location specified by the address pins appears on the I/O pins.

The CY7C199D device is suitable for interfacing with processors that have TTL I/P levels. It is not suitable for processors that require CMOS I/P levels. Please see [Electrical Characteristics on page 4](#) for more details and suggested alternatives.

For a complete list of related documentation, [click here](#).

Logic Block Diagram

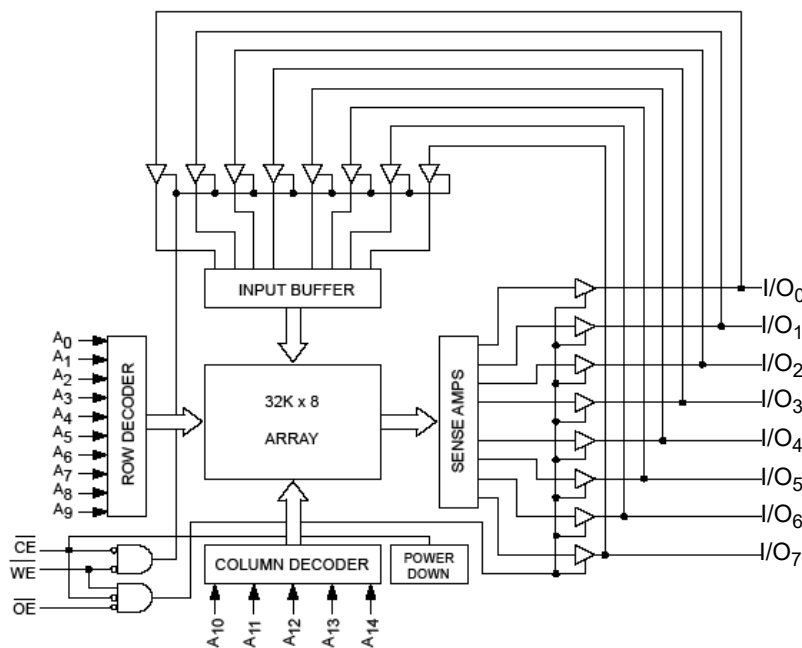

Contents

Pin Configurations	3	Ordering Information	10
Selection Guide	3	Ordering Code Definitions	10
Maximum Ratings	4	Package Diagrams	11
Operating Range	4	Acronyms	13
Electrical Characteristics	4	Document Conventions	13
Capacitance	5	Units of Measure	13
Thermal Resistance	5	Document History Page	14
AC Test Loads and Waveforms	5	Sales, Solutions, and Legal Information	16
Data Retention Characteristics	6	Worldwide Sales and Design Support	16
Data Retention Waveform	6	Products	16
Switching Characteristics	7	PSoC® Solutions	16
Switching Waveforms	8	Cypress Developer Community	16
Truth Table	10	Technical Support	16

Pin Configurations

Figure 1. 28-pin SOJ pinout (Top View)

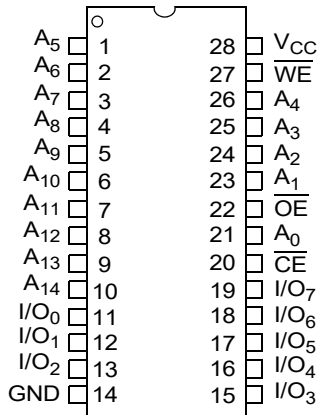
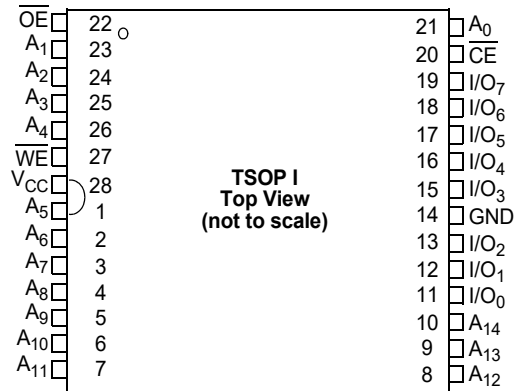

Figure 2. 28-pin TSOP I pinout (Top View)



Selection Guide

Description	-10 (Industrial)	Unit
Maximum access time	10	ns
Maximum operating current	80	mA
Maximum CMOS standby current	3	mA

Maximum Ratings

Exceeding the maximum ratings may impair the useful life of the device. These user guidelines are not tested.

Storage temperature -65 °C to +150 °C
 Ambient temperature
 with power applied -55 °C to +125 °C
 Supply voltage
 on V_{CC} to relative GND ^[1] -0.5 V to +6.0 V
 DC voltage applied to outputs
 in high Z State ^[1] -0.5 V to $V_{CC} + 0.5$ V

DC input voltage ^[1] -0.5 V to $V_{CC} + 0.5$ V
 Output current into outputs (LOW) 20 mA
 Static discharge voltage
 (per MIL-STD-883, method 3015) > 2,001 V
 Latch-up current > 140 mA

Operating Range

Range	Ambient Temperature	V_{CC}	Speed
Industrial	-40 °C to +85 °C	5 V ± 0.5 V	10 ns

Electrical Characteristics

Over the operating range

Parameter	Description	Test Conditions	CY7C199D-10		Unit	
			Min	Max		
V_{OH}	Output HIGH voltage	$I_{OH} = -4.0$ mA	2.4	-	V	
		$I_{OH} = -0.1$ mA	-	3.4 ^[2]		
V_{OL}	Output LOW voltage	$I_{OL} = 8.0$ mA	-	0.4	V	
V_{IH}	Input HIGH voltage ^[1]		2.2	$V_{CC} + 0.5$	V	
V_{IL}	Input LOW voltage ^[1]		-0.5	0.8	V	
I_{IX}	Input leakage current	$GND \leq V_I \leq V_{CC}$	-1	+1	µA	
I_{OZ}	Output leakage current	$GND \leq V_O \leq V_{CC}$, output disabled	-1	+1	µA	
I_{CC}	V_{CC} operating supply current	$V_{CC} = V_{CC(max)}$, $I_{OUT} = 0$ mA, $f = f_{max} = 1/t_{RC}$	100 MHz	-	80	mA
			83 MHz	-	72	mA
			66 MHz	-	58	mA
			40 MHz	-	37	mA
I_{SB1}	Automatic CE power-down current – TTL Inputs	$V_{CC} = V_{CC(max)}$, $\overline{CE} \geq V_{IH}$, $V_{IN} \geq V_{IH}$ or $V_{IN} \leq V_{IL}$, $f = f_{max}$	-	10	mA	
I_{SB2}	Automatic CE power-down current – CMOS Inputs	$V_{CC} = V_{CC(max)}$, $\overline{CE} \geq V_{CC} - 0.3$ V, $V_{IN} \geq V_{CC} - 0.3$ V or $V_{IN} \leq 0.3$ V, $f = 0$	-	3	mA	

Note

- $V_{IL(min)} = -2.0$ V and $V_{IH(max)} = V_{CC} + 1$ V for pulse durations of less than 5 ns.
- Please note that the maximum V_{OH} limit does not exceed minimum CMOS V_{IH} of 3.5 V. If you are interfacing this SRAM with 5 V legacy processors that require a minimum V_{IH} of 3.5 V, please refer to Application Note [AN6081](#) for technical details and options you may consider.

Capacitance

Parameter ^[3]	Description	Test Conditions	Max	Unit
C _{IN}	Input capacitance	T _A = 25 °C, f = 1 MHz, V _{CC} = 5.0 V	8	pF
C _{OUT}	Output capacitance		8	pF

Thermal Resistance

Parameter ^[3]	Description	Test Conditions	28-pin SOJ	28-pin TSOP I	Unit
Θ _{JA}	Thermal resistance (junction to ambient)	Still air, soldered on a 3 × 4.5 inch, four-layer printed circuit board	59.16	54.65	°C/W
Θ _{JC}	Thermal resistance (junction to case)		40.84	21.49	°C/W

AC Test Loads and Waveforms

Figure 3. AC Test Loads and Waveforms ^[4]

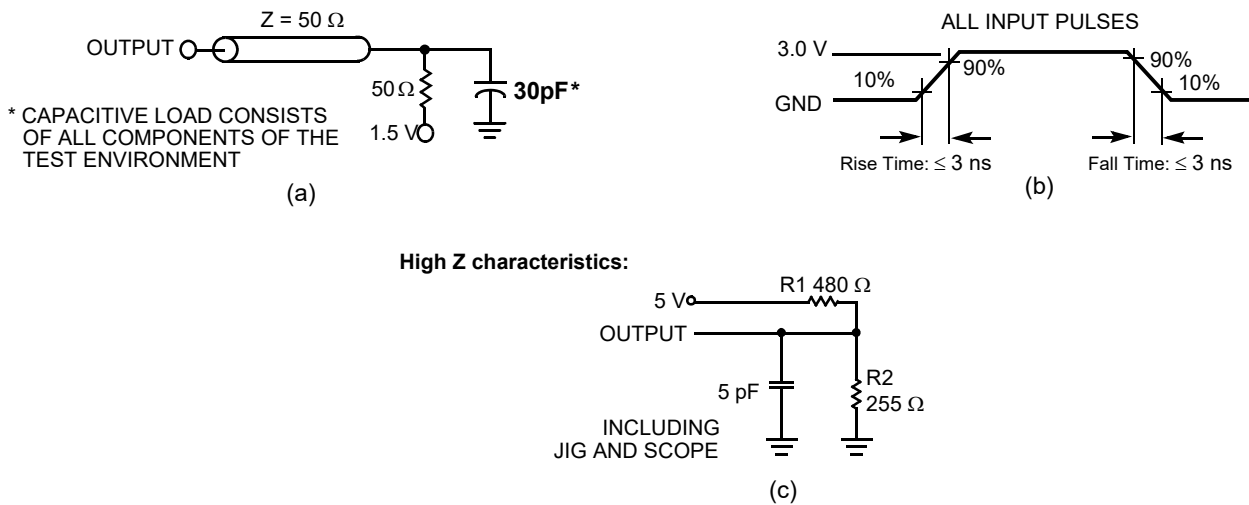

Notes

- 3. Tested initially and after any design or process changes that may affect these parameters.
- 4. AC characteristics (except high Z) are tested using the load conditions shown in Figure 3 (a). High Z characteristics are tested for all speeds using the test load shown in Figure 3 (c).

Data Retention Characteristics

Over the operating range

Parameter	Description	Conditions	Min	Max	Unit
V_{DR}	V_{CC} for data retention		2.0	–	V
I_{CCDR}	Data retention current	$V_{CC} = V_{DR} = 2.0\text{ V}$, $\overline{CE} \geq V_{CC} - 0.3\text{ V}$, $V_{IN} \geq V_{CC} - 0.3\text{ V}$ or $V_{IN} \leq 0.3\text{ V}$	–	3	mA
$t_{CDR}^{[5]}$	Chip deselect to data retention time		0	–	ns
$t_R^{[6]}$	Operation recovery time		15	–	ns

Data Retention Waveform

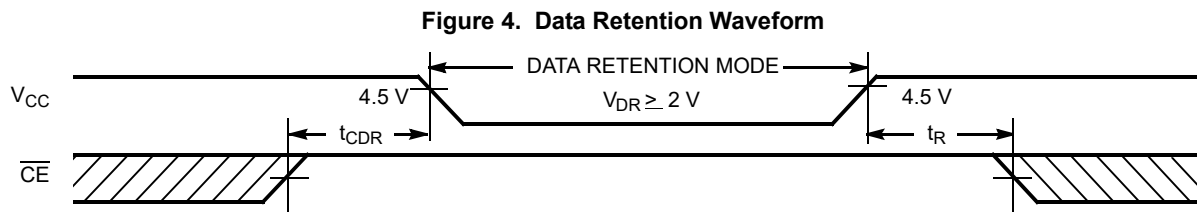

Notes

- 5. Tested initially and after any design or process changes that may affect these parameters.
- 6. Full device operation requires linear V_{CC} ramp from V_{DR} to $V_{CC(min)} \geq 50\ \mu\text{s}$ or stable at $V_{CC(min)} \geq 50\ \mu\text{s}$.

Switching Characteristics

Over the operating range

Parameter ^[7]	Description	CY7C199D-10		Unit
		Min	Max	
Read Cycle				
$t_{\text{power}}^{[8]}$	$V_{\text{CC}}(\text{typical})$ to the first access	100	–	μs
t_{RC}	Read cycle time	10	–	ns
t_{AA}	Address to data valid	–	10	ns
t_{OHA}	Data hold from address change	3	–	ns
t_{ACE}	$\overline{\text{CE}}$ LOW to data valid	–	10	ns
t_{DOE}	$\overline{\text{OE}}$ LOW to data valid	–	5	ns
$t_{\text{LZOE}}^{[9]}$	$\overline{\text{OE}}$ LOW to low Z	0	–	ns
$t_{\text{HZOE}}^{[9, 10]}$	$\overline{\text{OE}}$ HIGH to high Z	–	5	ns
$t_{\text{LZCE}}^{[9]}$	$\overline{\text{CE}}$ LOW to low Z	3	–	ns
$t_{\text{HZCE}}^{[9, 10]}$	$\overline{\text{CE}}$ HIGH to high Z	–	5	ns
$t_{\text{PU}}^{[11]}$	$\overline{\text{CE}}$ LOW to power-up	0	–	ns
$t_{\text{PD}}^{[11]}$	$\overline{\text{CE}}$ HIGH to power-down	–	10	ns
Write Cycle ^[12, 13]				
t_{WC}	Write cycle time	10	–	ns
t_{SCE}	$\overline{\text{CE}}$ LOW to write end	7	–	ns
t_{AW}	Address setup to write end	7	–	ns
t_{HA}	Address hold from write end	0	–	ns
t_{SA}	Address setup to write start	0	–	ns
t_{PWE}	$\overline{\text{WE}}$ pulse width	7	–	ns
t_{SD}	Data setup to write end	6	–	ns
t_{HD}	Data hold from write end	0	–	ns
$t_{\text{HZWE}}^{[9]}$	$\overline{\text{WE}}$ LOW to high Z	–	5	ns
$t_{\text{LZWE}}^{[9, 10]}$	$\overline{\text{WE}}$ HIGH to low Z	3	–	ns

Notes

7. Test conditions assume signal transition time of 3 ns or less for all speeds, timing reference levels of 1.5 V, input pulse levels of 0 to 3.0 V, and output loading of the specified $I_{\text{OL}}/I_{\text{OH}}$ and 30-pF load capacitance.
8. t_{POWER} gives the minimum amount of time that the power supply should be at typical V_{CC} values until the first memory access can be performed.
9. At any given temperature and voltage condition, t_{HZCE} is less than t_{LZCE} , t_{HZOE} is less than t_{LZOE} , and t_{HZWE} is less than t_{LZWE} for any given device.
10. t_{HZOE} , t_{HZCE} , and t_{HZWE} are specified with $C_{\text{L}} = 5$ pF as in part (b) of [Figure 3 on page 5](#). Transition is measured ± 200 mV from steady-state voltage.
11. This parameter is guaranteed by design and is not tested.
12. The internal write time of the memory is defined by the overlap of $\overline{\text{CE}}$ LOW and $\overline{\text{WE}}$ LOW. Both signals must be LOW to initiate a write and either signal can terminate a write by going HIGH. The data input setup and hold timing should be referenced to the rising edge of the signal that terminates the write.
13. The minimum write cycle time for Write Cycle No. 3 ($\overline{\text{WE}}$ controlled, $\overline{\text{OE}}$ LOW) is the sum of t_{HZWE} and t_{SD} .

Switching Waveforms

Figure 5. Read Cycle No. 1 (Address Transition Controlled) [14, 15]

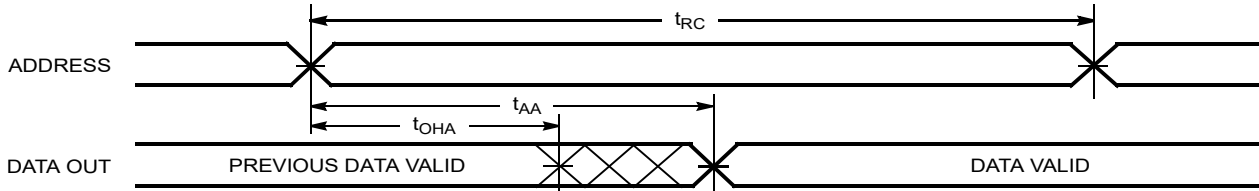
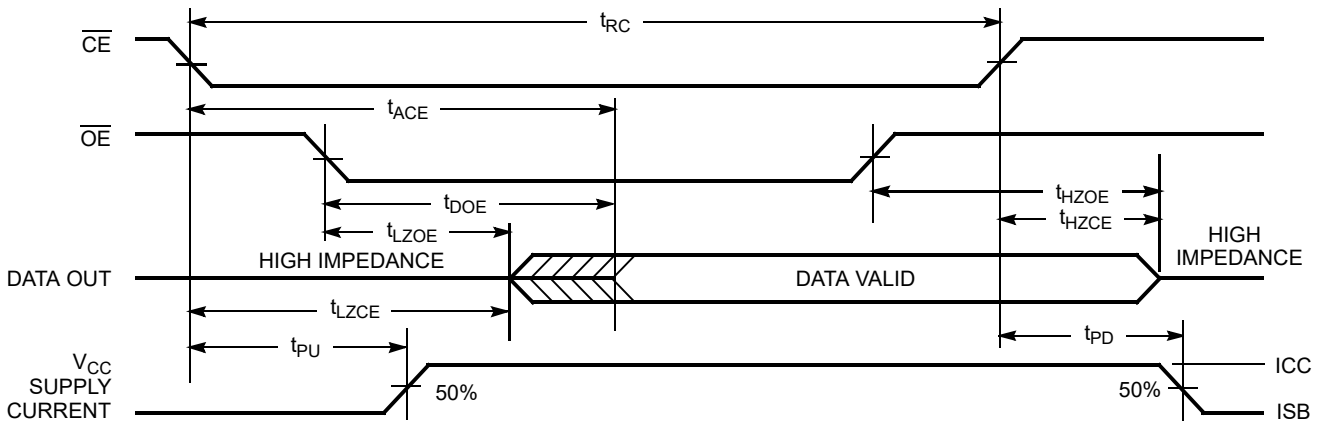

Figure 6. Read Cycle No. 2 (\overline{OE} Controlled) [15, 16]



Notes

- 14. Device is continuously selected. $\overline{OE}, \overline{CE} = V_{IL}$.
- 15. \overline{WE} is HIGH for read cycle.
- 16. Address valid prior to or coincident with \overline{CE} transition LOW.

Switching Waveforms (continued)

Figure 7. Write Cycle No. 1 ($\overline{\text{CE}}$ Controlled) [17, 18, 19]

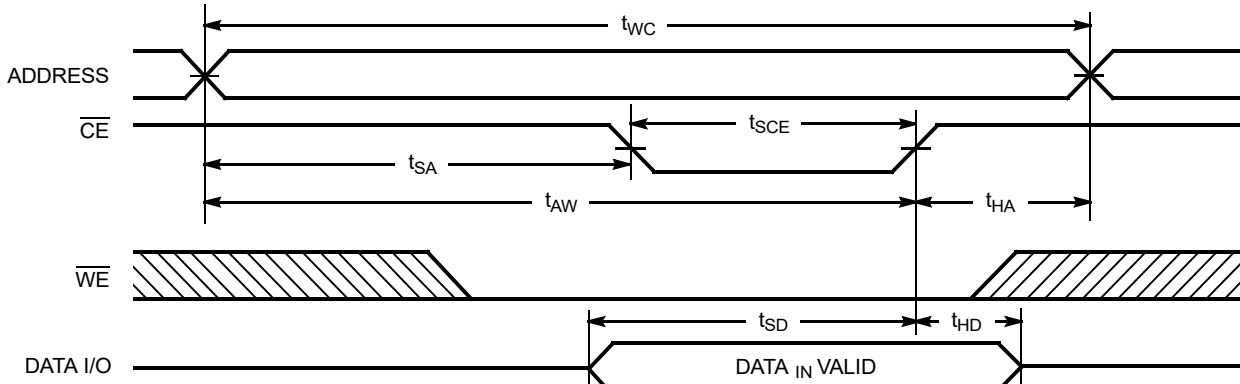
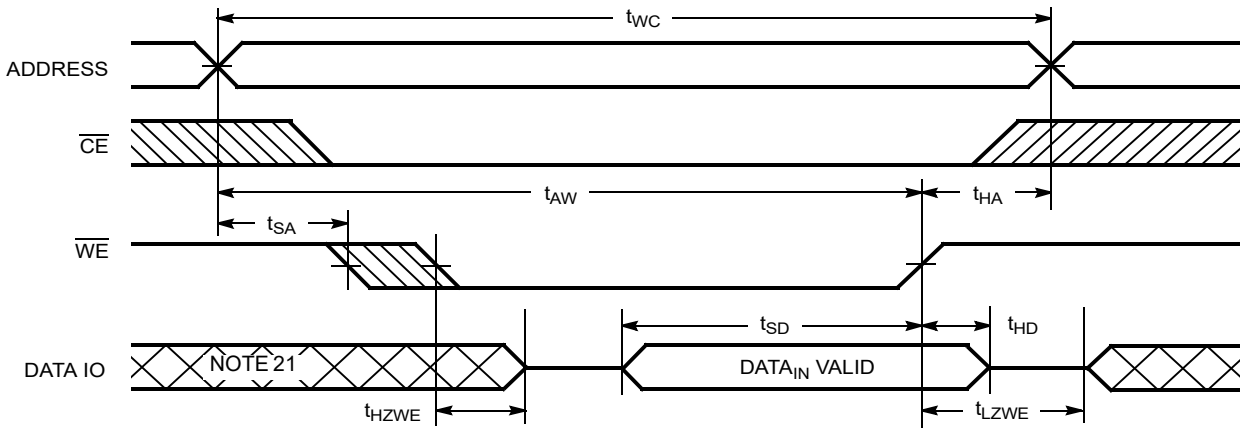

Figure 8. Write Cycle No. 3 ($\overline{\text{WE}}$ Controlled, $\overline{\text{OE}}$ LOW) [19, 20]



Notes

- 17. The internal write time of the memory is defined by the overlap of $\overline{\text{CE}}$ LOW and $\overline{\text{WE}}$ LOW. Both signals must be LOW to initiate a write and either signal can terminate a write by going HIGH. The data input setup and hold timing should be referenced to the rising edge of the signal that terminates the write.
- 18. Data I/O is high impedance if $\overline{\text{OE}} = V_{\text{IH}}$.
- 19. If $\overline{\text{CE}}$ goes HIGH simultaneously with $\overline{\text{WE}}$ HIGH, the output remains in a high-impedance state.
- 20. The minimum write cycle time for Write Cycle No. 3 ($\overline{\text{WE}}$ controlled, $\overline{\text{OE}}$ LOW) is the sum of t_{HZWE} and t_{SD} .
- 21. During this period the I/Os are in the output state and input signals should not be applied.

Truth Table

\overline{CE}	\overline{WE}	\overline{OE}	Inputs/Outputs	Mode	Power
H	X	X	High Z	Deselect/power-down	Standby (I_{SB})
L	H	L	Data out	Read	Active (I_{CC})
L	L	X	Data in	Write	Active (I_{CC})
L	H	H	High Z	Deselect, output disabled	Active (I_{CC})

Ordering Information

Cypress offers other versions of this type of product in many different configurations and features. The following table contains only the list of parts that are currently available. For a complete listing of all options, visit the Cypress website at <http://www.cypress.com> and refer to the product summary page at <http://www.cypress.com/products> or contact your local sales representative.

Cypress maintains a worldwide network of offices, solution centers, manufacturer's representatives and distributors. To find the office closest to you, visit us at <http://www.cypress.com/go/datasheet/offices>.

Speed (ns)	Ordering Code	Package Diagram	Package Type	Operating Range
10	CY7C199D-10VXI	51-85031	28-pin Molded SOJ (300 Mils) (Pb-free)	Industrial
	CY7C199D-10ZXI	51-85071	28-pin TSOP I (Pb-free)	

Please contact your local Cypress sales representative for availability of these parts.

Ordering Code Definitions

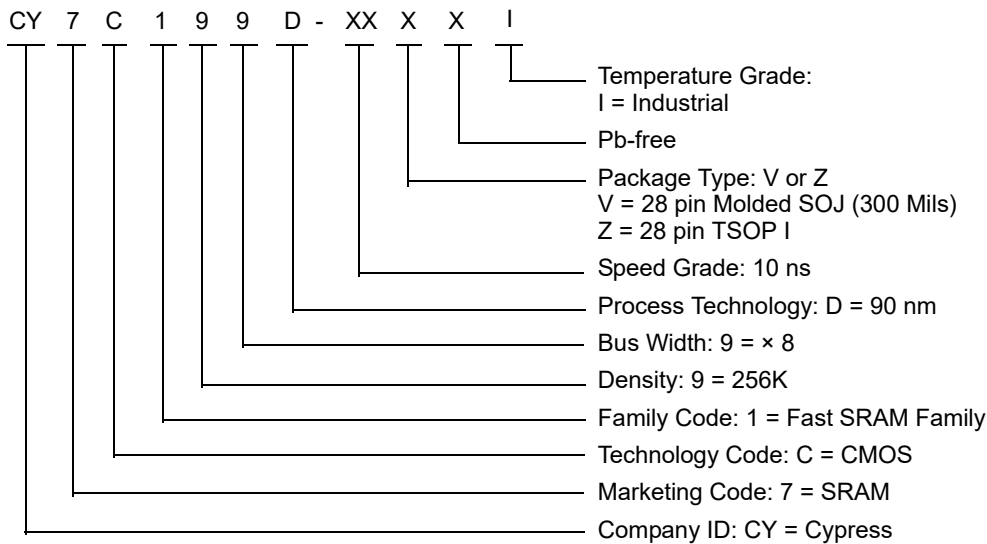

Package Diagrams

Figure 9. 28-pin SOJ (300 Mils) V28.3 (Molded SOJ V21) Package Outline, 51-85031

NOTE :

1. JEDEC STD REF MO088
2. BODY LENGTH DIMENSION DOES NOT INCLUDE MOLD PROTRUSION/END FLASH
MOLD PROTRUSION/END FLASH SHALL NOT EXCEED 0.006 in (0.152 mm) PER SIDE
3. DIMENSIONS IN INCHES MIN.
MAX.

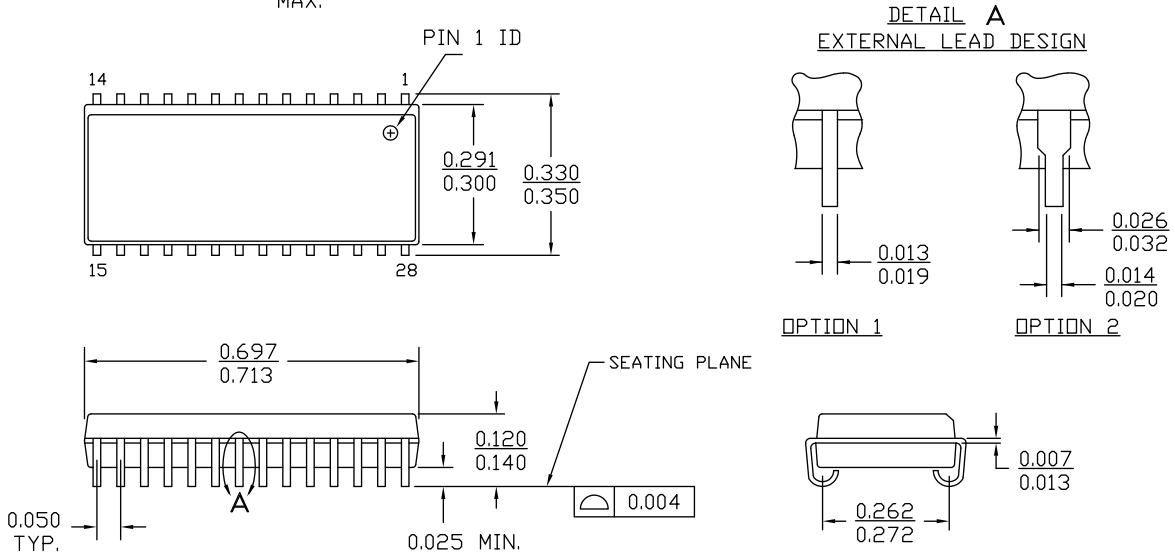

51-85031 *F

Package Diagrams (continued)

Figure 10. 28-pin TSOP I (8 × 13.4 × 1.2 mm) Z28R (Standard) Package Outline, 51-85071

NOTE: ORIENTATION I.D. MAY BE LOCATED EITHER AS SHOWN IN OPTION 1 OR OPTION 2

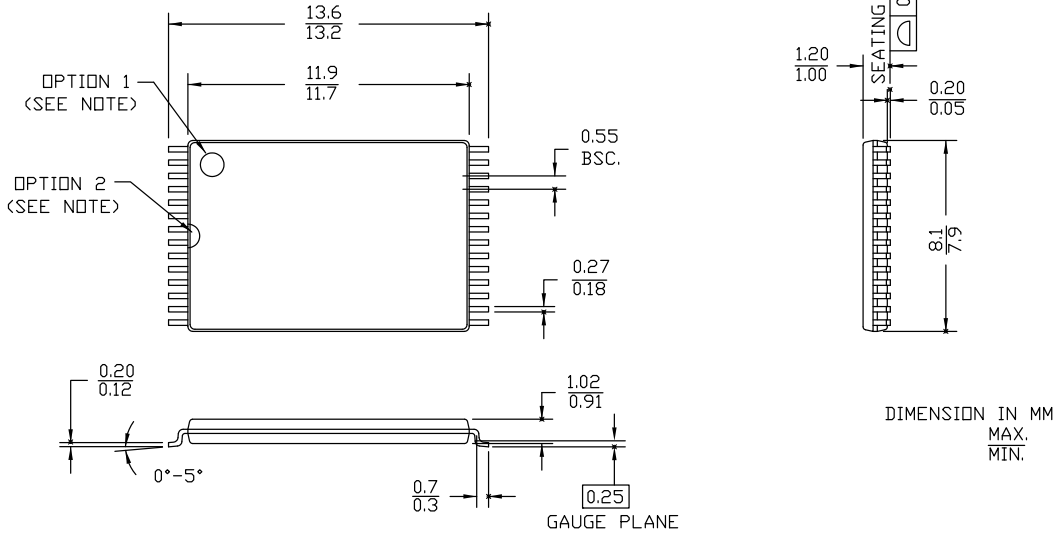

51-85071 *J

Acronyms

Acronym	Description
\overline{CE}	Chip Enable
CMOS	Complementary Metal Oxide Semiconductor
I/O	Input/Output
\overline{OE}	Output Enable
SOJ	Small Outline J-lead
SRAM	Static Random Access Memory
TSOP	Thin Small Outline Package
TTL	Transistor-Transistor Logic
\overline{WE}	Write Enable

Document Conventions

Units of Measure

Symbol	Unit of Measure
°C	degree Celsius
μA	microampere
μs	microsecond
mA	milliampere
mm	millimeter
ns	nanosecond
pF	picofarad
V	volt
W	watt

Document History Page

Document Title: CY7C199D, 256-Kbit (32K × 8) Static RAM Document Number: 38-05471				
Revision	ECN	Orig. of Change	Submission Date	Description of Change
**	201560	SWI	01/09/2004	Advance Information data sheet for C9 IPP.
*A	233728	RKF	06/14/2004	DC parameters modified as per EROS (spec 01-02165). Updated Ordering Information : Updated part numbers.
*B	262950	RKF	09/11/2004	Changed status from Advance Information to Preliminary. Removed 28-pin LCC related information in all instances across the document. Updated Data Retention Characteristics : Updated details in "Min" and "Max" columns corresponding to I _{CCDR} and t _R parameters. Updated Data Retention Waveform : Updated Figure 4 . Updated Switching Characteristics : Added t _{power} parameter and its corresponding details. Updated Ordering Information : No change in part numbers. Shaded the table. Updated Package Diagrams : spec 51-85014 – Changed revision from *C to *D. Removed spec 51-80067 **.
*C	307594	RKF	01/12/2005	Removed 20 ns speed bin related information in all instances across the document.
*D	820660	VKN	03/07/2007	Changed status from Preliminary to Final. Removed 12 ns and 15 ns speed bins related information in all instances across the document. Removed Commercial Temperature Range related information in all instances across the document. Removed 28-pin PDIP and 28-pin SOIC Packages related information in all instances across the document. Updated Selection Guide : Removed "L" related information from the part numbers. Updated Electrical Characteristics : Updated Note 1. Referred Note 1 in description of V _{IH} and V _{IL} parameters. Updated details in "Test Conditions", "Min" and "Max" columns corresponding to I _{CC} parameter. Updated Thermal Resistance : Replaced TBD with values for 28-pin SOJ and 28-pin TSOP I packages. Updated Ordering Information : Updated part numbers. Updated to new template.
*E	2745093	VKN	07/28/2009	Added 28-pin SOIC Package related information in all instances across the document. Added Automotive-E Temperature Range related information in all instances across the document. Added 25 ns speed bin related information in all instances across the document. Updated Electrical Characteristics : Changed minimum value of V _{IH} parameter from 2.0 V to 2.2 V corresponding to 10 ns speed bin.

Document History Page (continued)

Document Title: CY7C199D, 256-Kbit (32K × 8) Static RAM				
Document Number: 38-05471				
Revision	ECN	Orig. of Change	Submission Date	Description of Change
*E (cont.)	2745093	VKN	07/28/2009	Updated Switching Characteristics : Changed minimum value of t_{SD} parameter from 5 ns to 6 ns corresponding to 10 ns speed bin. Changed maximum value of t_{HZWE} parameter from 6 ns to 5 ns corresponding to 10 ns speed bin.
*F	2897087	AJU	03/22/2010	Updated Ordering Information : Updated part numbers. Updated Package Diagrams : spec 51-85031 – Changed revision from *C to *D. Removed spec 51-85026 *D. spec 51-85071 – Changed revision from *G to *H.
*G	3023234	RAME	09/06/2010	Updated Switching Characteristics : Changed maximum value of t_{DOE} parameter from 10 ns to 11 ns corresponding to 25 ns speed bin. Updated Ordering Information : Updated part numbers. Added Ordering Code Definitions . Added Acronyms and Units of Measure .
*H	3130763	PRAS	01/07/2011	Removed Automotive-E Temperature Range related information in all instances across the document. Dislodged Automotive information to a new datasheet (001-65530). Completing Sunset Review.
*I	3271782	PRAS	06/02/2011	Updated Functional Description : Updated description. Updated Package Diagrams : spec 51-85071 – Changed revision from *H to *I. Removed spec 51-85026 *E. Updated to new template.
*J	4033580	MEMJ	06/19/2013	Updated Functional Description : Updated description. Updated Electrical Characteristics : Added one more Test Condition " $I_{OH} = -0.1$ mA" for V_{OH} parameter and added maximum value corresponding to that Test Condition. Added Note 2 and referred the same note in maximum value for V_{OH} parameter corresponding to Test Condition " $I_{OH} = -0.1$ mA". Updated Package Diagrams : spec 51-85031 – Changed revision from *D to *E.
*K	4347624	MEMJ	04/15/2014	Updated Package Diagrams : spec 51-85071 – Changed revision from *I to *J. Completing Sunset Review.
*L	4576526	MEMJ	11/21/2014	Updated Functional Description : Added "For a complete list of related documentation, click here ." at the end.
*M	5725425	VINI	05/04/2017	Updated Package Diagrams : spec 51-85031 – Changed revision from *E to *F. Updated to new template. Completing Sunset Review.
*N	6518606	VINI	03/22/2019	Updated to new template. Completing Sunset Review.

Sales, Solutions, and Legal Information

Worldwide Sales and Design Support

Cypress maintains a worldwide network of offices, solution centers, manufacturer's representatives, and distributors. To find the office closest to you, visit us at [Cypress Locations](#).

Products

Arm® Cortex® Microcontrollers	cypress.com/arm
Automotive	cypress.com/automotive
Clocks & Buffers	cypress.com/clocks
Interface	cypress.com/interface
Internet of Things	cypress.com/iot
Memory	cypress.com/memory
Microcontrollers	cypress.com/mcu
PSoC	cypress.com/psoc
Power Management ICs	cypress.com/pmic
Touch Sensing	cypress.com/touch
USB Controllers	cypress.com/usb
Wireless Connectivity	cypress.com/wireless

PSoC® Solutions

[PSoC 1](#) | [PSoC 3](#) | [PSoC 4](#) | [PSoC 5LP](#) | [PSoC 6 MCU](#)

Cypress Developer Community

[Community](#) | [Projects](#) | [Video](#) | [Blogs](#) | [Training](#) | [Components](#)

Technical Support

cypress.com/support



© Cypress Semiconductor Corporation, 2004–2019. This document is the property of Cypress Semiconductor Corporation and its subsidiaries ("Cypress"). This document, including any software or firmware included or referenced in this document ("Software"), is owned by Cypress under the intellectual property laws and treaties of the United States and other countries worldwide. Cypress reserves all rights under such laws and treaties and does not, except as specifically stated in this paragraph, grant any license under its patents, copyrights, trademarks, or other intellectual property rights. If the Software is not accompanied by a license agreement and you do not otherwise have a written agreement with Cypress governing the use of the Software, then Cypress hereby grants you a personal, non-exclusive, nontransferable license (without the right to sublicense) (1) under its copyright rights in the Software (a) for Software provided in source code form, to modify and reproduce the Software solely for use with Cypress hardware products, only internally within your organization, and (b) to distribute the Software in binary code form externally to end users (either directly or indirectly through resellers and distributors), solely for use on Cypress hardware product units, and (2) under those claims of Cypress's patents that are infringed by the Software (as provided by Cypress, unmodified) to make, use, distribute, and import the Software solely for use with Cypress hardware products. Any other use, reproduction, modification, translation, or compilation of the Software is prohibited.

TO THE EXTENT PERMITTED BY APPLICABLE LAW, CYPRESS MAKES NO WARRANTY OF ANY KIND, EXPRESS OR IMPLIED, WITH REGARD TO THIS DOCUMENT OR ANY SOFTWARE OR ACCOMPANYING HARDWARE, INCLUDING, BUT NOT LIMITED TO, THE IMPLIED WARRANTIES OF MERCHANTABILITY AND FITNESS FOR A PARTICULAR PURPOSE. No computing device can be absolutely secure. Therefore, despite security measures implemented in Cypress hardware or software products, Cypress shall have no liability arising out of any security breach, such as unauthorized access to or use of a Cypress product. CYPRESS DOES NOT REPRESENT, WARRANT, OR GUARANTEE THAT CYPRESS PRODUCTS, OR SYSTEMS CREATED USING CYPRESS PRODUCTS, WILL BE FREE FROM CORRUPTION, ATTACK, VIRUSES, INTERFERENCE, HACKING, DATA LOSS OR THEFT, OR OTHER SECURITY INTRUSION (collectively, "Security Breach"). Cypress disclaims any liability relating to any Security Breach, and you shall and hereby do release Cypress from any claim, damage, or other liability arising from any Security Breach. In addition, the products described in these materials may contain design defects or errors known as errata which may cause the product to deviate from published specifications. To the extent permitted by applicable law, Cypress reserves the right to make changes to this document without further notice. Cypress does not assume any liability arising out of the application or use of any product or circuit described in this document. Any information provided in this document, including any sample design information or programming code, is provided only for reference purposes. It is the responsibility of the user of this document to properly design, program, and test the functionality and safety of any application made of this information and any resulting product. "High-Risk Device" means any device or system whose failure could cause personal injury, death, or property damage. Examples of High-Risk Devices are weapons, nuclear installations, surgical implants, and other medical devices. "Critical Component" means any component of a High-Risk Device whose failure to perform can be reasonably expected to cause, directly or indirectly, the failure of the High-Risk Device, or to affect its safety or effectiveness. Cypress is not liable, in whole or in part, and you shall and hereby do release Cypress from any claim, damage, or other liability arising from any use of a Cypress product as a Critical Component in a High-Risk Device. You shall indemnify and hold Cypress, its directors, officers, employees, agents, affiliates, distributors, and assigns harmless from and against all claims, costs, damages, and expenses, arising out of any claim, including claims for product liability, personal injury or death, or property damage arising from any use of a Cypress product as a Critical Component in a High-Risk Device. Cypress products are not intended or authorized for use as a Critical Component in any High-Risk Device except to the limited extent that (i) Cypress's published data sheet for the product explicitly states Cypress has qualified the product for use in a specific High-Risk Device, or (ii) Cypress has given you advance written authorization to use the product as a Critical Component in the specific High-Risk Device and you have signed a separate indemnification agreement.







Cypress, the Cypress logo, Spansion, the Spansion logo, and combinations thereof, WICED, PSoC, CapSense, EZ-USB, F-RAM, and Traveo are trademarks or registered trademarks of Cypress in the United States and other countries. For a more complete list of Cypress trademarks, visit cypress.com. Other names and brands may be claimed as property of their respective owners.

Looking for pricing, stock, or lifecycle information?

Click below to explore more details on WIN SOURCE:

-  [View CY7C199D-10VXIT on WIN SOURCE](#)
-  [Cypress Semiconductor Corp Information](#)

Optimize Your Supply Chain with WIN SOURCE Solutions

-  Global Sourcing Solution
-  Obsolete Management
-  Cost Control Management
-  Shortage Management
-  Alternative Solution
-  Excess Inventory Management