



**THE DATASHEET OF
SSL21101T/1,518**





SSL21101T

GreenChip driver for LED lighting

Rev. 3 — 7 June 2012

Product data sheet

1. General description

The SSL21101T is a Switch Mode Power Supply (SMPS) driver IC. It is designed to drive LED devices typically in flyback configurations. The device includes a high-voltage power switch and a circuit enabling start-up directly from the rectified mains voltage. It has accurate control of the output current.

2. Features and benefits

- Small Printed-Circuit Board (PCB) footprint and compact solution with a small form factor
- Ease of integration
- Low component count (complete application with about 25 components)
- AC/DC offline non-dimmable LED driver from 100 V (AC) to 230 V (AC)
- Primary side sensing (no optocoupler required)
- True current source behavior:
 - ◆ LED current independent of mains voltage, LED voltage, temperature and coil variation
 - ◆ High LED current accuracy ($\pm 3\%$)
- Efficiency up to 90 % depending on the application
- Smart Digital Control (SDC) to deal with all kind of applications:
 - ◆ High-Power Factor (PF; > 0.95) and low Total Harmonic Distortion Mode (THD down to 20 %)
 - ◆ Small form factor (low LED current mode ripple with small electrolytic capacitors) - compatible with exception clause IEC61000-3-2
- Internal protections:
 - ◆ Short-winding protection
 - ◆ Internal OverTemperature Protection (OTP)
 - ◆ LED short protection
 - ◆ LED open protection
 - ◆ UnderVoltage LockOut (UVLO)
- External temperature protection with built-in Negative Temperature Coefficient (NTC)
- Internal supply voltage generation enabling start-up from the rectified mains voltage
- Compatible with wall switches with built-in indication light during standby
- SO14 package



3. Applications

- The SSL21101T is suitable for different power requirements:
 - ◆ SSL, retrofit lamps (for example: small-size light bulbs, LED spots, up to 10 W or 12 W)
 - ◆ LED modules, mains AC/DC converter (for example: down-lights, up to 15 W)
 - ◆ LED strings (for example: retail display; up to 15 W)

4. Quick reference data

Table 1. Quick reference data

Symbol	Parameter	Conditions	Min	Typ	Max	Unit
V_{CC}	supply voltage	functional	13	22	25.5	V
R_{DSon}	drain-source on-state resistance	$T_j = 25\text{ °C}$	-	6.8	-	Ω
		$T_j = 125\text{ °C}$	-	9.5	-	Ω
$f_{sw(max)}$	maximum switching frequency	DCM mode; main = 50 Hz; mode = 50 kHz	[1] 49.7	51.2	52.7	kHz
		DCM mode; main = 60 Hz; mode = 50 kHz	[1] 59.7	61.4	63.2	kHz
		DCM mode; modemain = 50 Hz; mode = 100 kHz	[1] 99.4	102.4	105.4	kHz
		DCM mode; main = 60 Hz; mode = 100 kHz	[1] 119.4	122.9	126.4	kHz
$I_{M(DRAIN)}$	peak current on pin DRAIN		0	-	1.2	A
V_{DRAIN}	voltage on pin DRAIN		-0.4	-	+700	V

[1] For a given $V_{I(ILEDREF)}$ and $V_{NTC} > 1.25\text{ V}$. See [Table 5](#).

5. Ordering information

Table 2. Ordering information

Type number	Package		Version
	Name	Description	
SSL21101T/1	SO14	plastic small outline package; 14 leads; body width 3.9 mm	SOT108-1

6. Block diagram

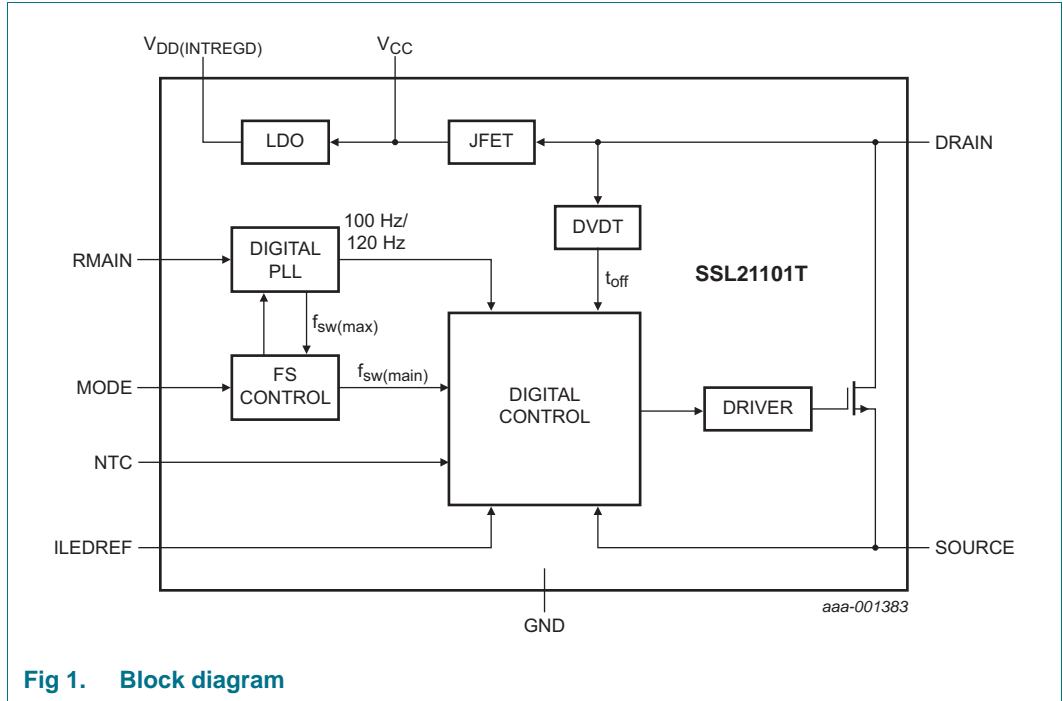

Fig 1. Block diagram

7. Pinning information

7.1 Pinning

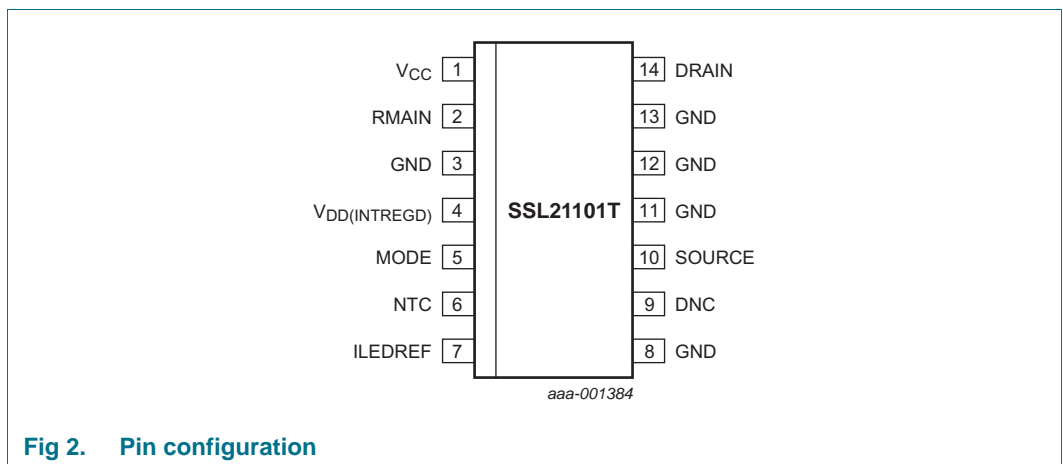

Fig 2. Pin configuration

7.2 Pin description

Table 3. Pin description

Symbol	Pin	Description
V _{CC}	1	supply voltage
RMAIN	2	current source proportionally equivalent of V _{main}
GND	3	ground
V _{DD(INTREGD)}	4	internal regulated supply
MODE	5	power factor/THD and maximum switching frequency control input
NTC	6	LED temperature protection input
ILEDREF	7	LED current control input
GND	8	ground
DNC	9	do not connect
SOURCE	10	source of internal power switch
GND	11	ground
GND	12	ground
GND	13	ground
DRAIN	14	drain of internal power switch

8. Functional description

The SSL21101T is an integrated circuit intended for retrofit small form factor SSL lamps. It provides a controller with an internal high-voltage switch to drive LEDs. It operates directly from the rectified mains.

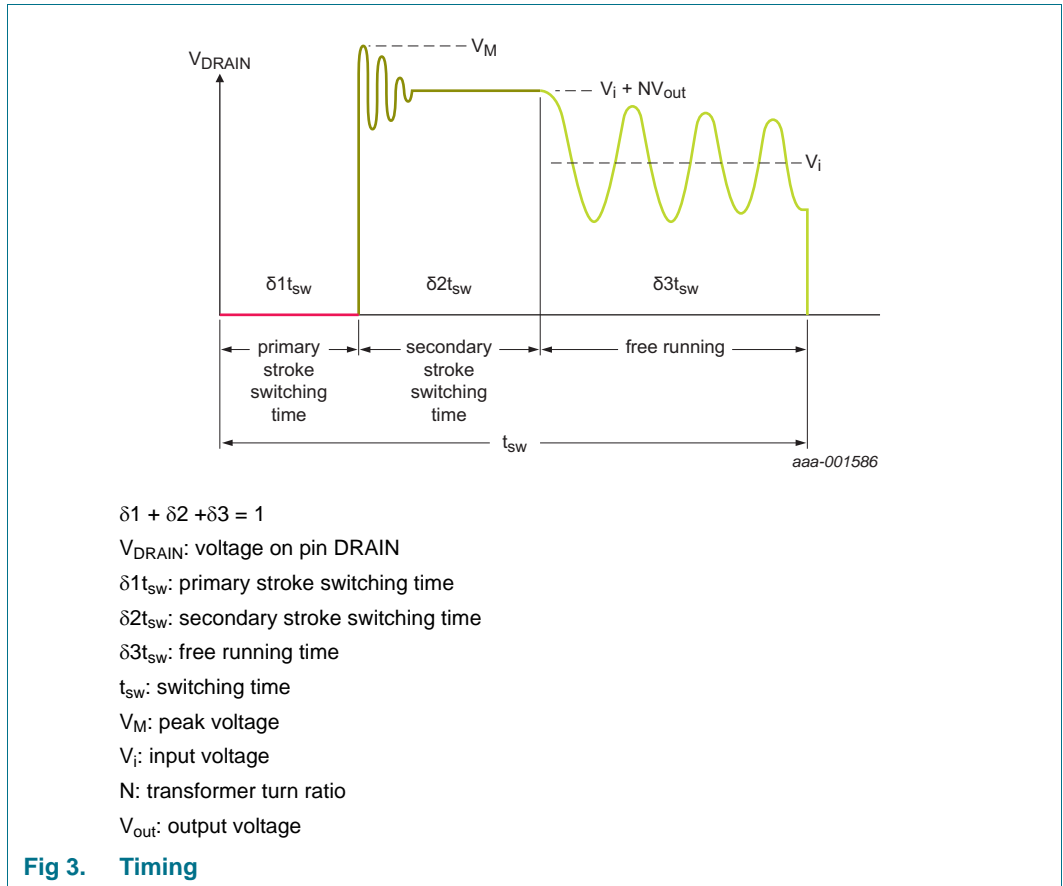

8.1 True current source behavior

The LED current (I_{LED}) of a flyback converter can be calculated with [Equation 1](#):

$$I_{LED} = \frac{1}{2} \times N \times I_M \times \frac{\delta 2 t_{sw}}{t_{sw}} \tag{1}$$

Where:

- N is the turn ratio of the transformer
- I_M is the peak current
- $\delta 2 t_{sw}$ is the secondary stroke switching time
- t_{sw} is the switching period

The relationship between the LED current and pin I_{LEDREF} can be calculated with [Equation 2](#):

$$I_{LED} = \frac{0.45 \times N \times V_{I(ILEDREF)}}{V_{DD(INTREGD)} \times R_{SOURCE}} \tag{2}$$

Where:

- $V_{I(ILEDREF)}$ is the voltage defined at the input of pin ILEDREF
- $V_{DD(INTREGD)}$ is the internal regulated voltage
- R_{SOURCE} is the resistor connected to pin SOURCE of the power MOS transistor.

The true current source behavior and the LED current accuracy are achieved using an internal digital control. The internal digital control compares the ILEDREF pin reference with the measurement of the average LED current over a half-main cycle. The primary peak current (I_M) is adjusted at each half-main cycle to achieve the expected LED current.

The expected primary peak current value on the application can be calculated with [Equation 3](#):

$$I_M = \frac{V_{th(det)SOURCE}}{R_{SOURCE}} \quad (3)$$

Where:

- $V_{th(det)SOURCE}$ is the detection threshold voltage on pin SOURCE
- R_{SOURCE} is the resistor connected to pin SOURCE of the power MOS transistor

8.2 Leading-Edge Blanking (LEB)

The controller automatically adjusts LEB to avoid wrong detection of the primary peak current.

8.3 dV/dt detection

A dV/dt detector block is used on pin DRAIN to detect the end of demagnetization and possible valleys accurately. A valley switching concept is used for efficiency purposes.

8.4 Secondary stroke switching time ($\delta 2t_{sw}$)

A blanking time (t_{blank}) is applied at the beginning of $\delta 2t_{sw}$ before observing the demagnetization.

$\delta 2t_{sw}$ must have a value that allows the application to run in DCM mode.

For example, for a 100 kHz switching frequency the application design must provide a typical secondary stroke switching time ($\delta 2t_{sw}$) ranging from 4 μ s to 6 μ s.

8.5 Mains sensing

Pin RMAIN senses the mains voltage (V_{main} in [Equation 4](#)) in real time and transforms it to mains current (I_{main} in [Equation 4](#)):

$$I_{main} = \frac{V_{main} \times \sqrt{2}}{R_{RMAIN}} \quad (4)$$

Table 4. Mains resistance/mains current dependency

Mains voltage	Mains resistance	Mains current
220 V (AC)/230 V (AC)	1 M Ω	300 μ A
100 V (AC)/120 V (AC)	470 k Ω	300 μ A

8.6 Modulation type versus MODE pin input

Pin MODE enables the control of both the THD/LED ripple and the switching frequency operation mode. This input has a range of 0 V to $V_{DD(INTREGD)}$. Depending on the mains frequency (50 Hz or 60 Hz), the following modes can be selected to ensure a flexible application.

- Low THD mode: for example, THD \approx 20 %; $C_i = 200$ nF for an 8 W application
- LR mode: $C_i = 2.2$ μ F for an 8 W application

Selecting a maximum switching frequency (50 kHz/60 kHz or 100 kHz/120 kHz) is also possible.

Table 5. MODE description

MODE voltage range	Behavior	Maximum switching frequency
$V_{DD(INTREGD)} \geq V_{MODE} > 5 \times V_{DD(INTREGD)} / 6$	low THD	100 kHz/120 kHz
$5 \times V_{DD(INTREGD)} / 6 > V_{MODE} > 4 \times V_{DD(INTREGD)} / 6$	low THD	50 kHz/60 kHz
$4 \times V_{DD(INTREGD)} / 6 > V_{MODE} > 2 \times V_{DD(INTREGD)} / 6$	not functional	not applicable
$2 \times V_{DD(INTREGD)} / 6 > V_{MODE} > 1 \times V_{DD(INTREGD)} / 6$	low ripple	50 kHz/60 kHz
$1 \times V_{DD(INTREGD)} / 6 > V_{MODE} \geq 0$	low ripple	100 kHz/120 kHz

The SSL21101T IC can reach a high-power factor in combination with a low THD without an external PFC. It can also reduce the LED current ripple when the low ripple mode is selected. Controlling the switching frequency value over a main cycle gives the input current waveform.

The modulation controller takes into account the information of the Boundary Conduction Mode (BCM) detection. The chip has optimized performances in Discontinuous Conduction Mode (DCM). The IC prevents that the application enters Continuous Conduction Mode (CCM) and forces it to enter Boundary Conduction Mode (BCM).

Remark: Select specific values for external components, such as transformers and R_{SOURCE} to avoid forced BCM, otherwise THD and the LED current ripple performances are directly impacted.

8.7 Supply concept: V_{CC} and UnderVoltage LockOut (UVLO)

An integrated Junction gate Field-Effect Transistor (JFET), connected to the drain voltage, provides the start-up current.

The IC starts switching when the voltage on pin V_{CC} exceeds the $V_{CC(startup)}$ level. After start-up, an external supply is required, which an auxiliary winding connection can provide. When the voltage on pin V_{CC} drops below the $V_{CC(UVLO)}$ level, the IC stops switching and is reset.

The IC is compatible with a wall switch with built-in light that is activated when wall switch is in the off position.

8.8 Peak current detection

The cycle-by-cycle peak drain current limit circuit uses the external source resistor R_{SOURCE} to measure the primary peak current. The circuit is activated after the leading edge blanking time. The protection circuit limits the source voltage over resistor R_{SOURCE} to $V_{th(det)SOURCE}$, thus limiting the primary peak current.

8.9 Overheating protection of the LEDs

Input pin NTC ensures the protection of the LEDs against overheating. The target is:

Table 6. NTC description

Temperature	LED current
$V_{NTC} > V_{det(H)(NTC)}$	LED current is 100 % of the expected LED current
$V_{det(H)(NTC)} > V_{NTC} > V_{det(L)(NTC)}$	Linear reduction of LED current: 25 %
$V_{det(L)(NTC)} > V_{NTC}$	Standby mode (LED current = 0)

Remark: After Standby mode, LED current only flows again when V_{NTC} exceeds $V_{det(H)(NTC)}$.

There are two detection levels on pin NTC:

- level 1 = $V_{det(H)(NTC)}$
- level 2 = $V_{det(L)(NTC)}$

These detection levels can be translated to temperature levels using an NTC resistor for which the levels have been optimized. [Figure 4](#) shows an application using a 100 kΩ NTC resistor and equivalent temperature detection levels.

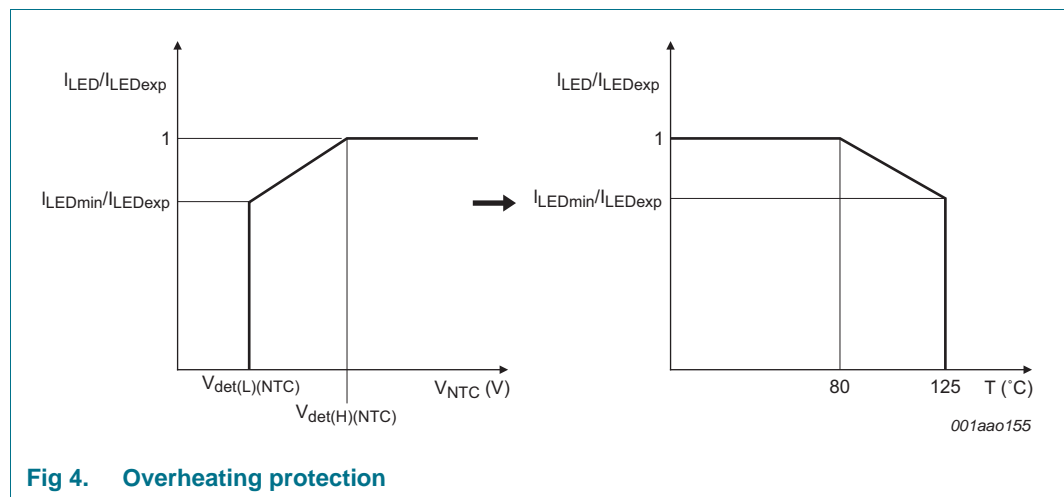

Fig 4. Overheating protection

8.10 Short-winding protection

The short-winding protection circuit is activated after the leading edge blanking time. If the source voltage exceeds the short-winding protection threshold voltage ($V_{th(swp)SOURCE}$), the IC stops switching. Only a power-on reset restarts normal operation (switching off the mains voltage).

8.11 Output LED short circuit protection

When during one rectified mains waveform the following conditions are true, the output short detection is activated and the IC enters Shutdown mode.

- $\delta 2t_{sw} > t_{prot(sc)LED}$
- $\delta 1t_{sw} < t_{on(high)}$

8.12 Output LED open circuit protection

If an open circuit occurs on the LEDs, the output voltage increases at each cycle of the AC/DC converter. Energy is no longer transferred to the LEDs. The energy accumulated at the primary side is transferred to the supply of the IC via the auxiliary winding. The IC enters Shutdown mode when V_{CC} reaches the $V_{prot(VCC)}$ value. Only a power-on reset restarts normal operation (switching off the mains voltage).

8.13 Limitations

The application must stay in DCM mode for normal functionality. During normal switching, the primary stroke switching time must stay under $t_{on(high)}$ to keep an accurate LED current.

When the application is working outside the defined main voltage range, meaning below the minimum mains voltage, the application can work in BCM mode. [Figure 5](#) shows some of the effects that can be seen in this case.

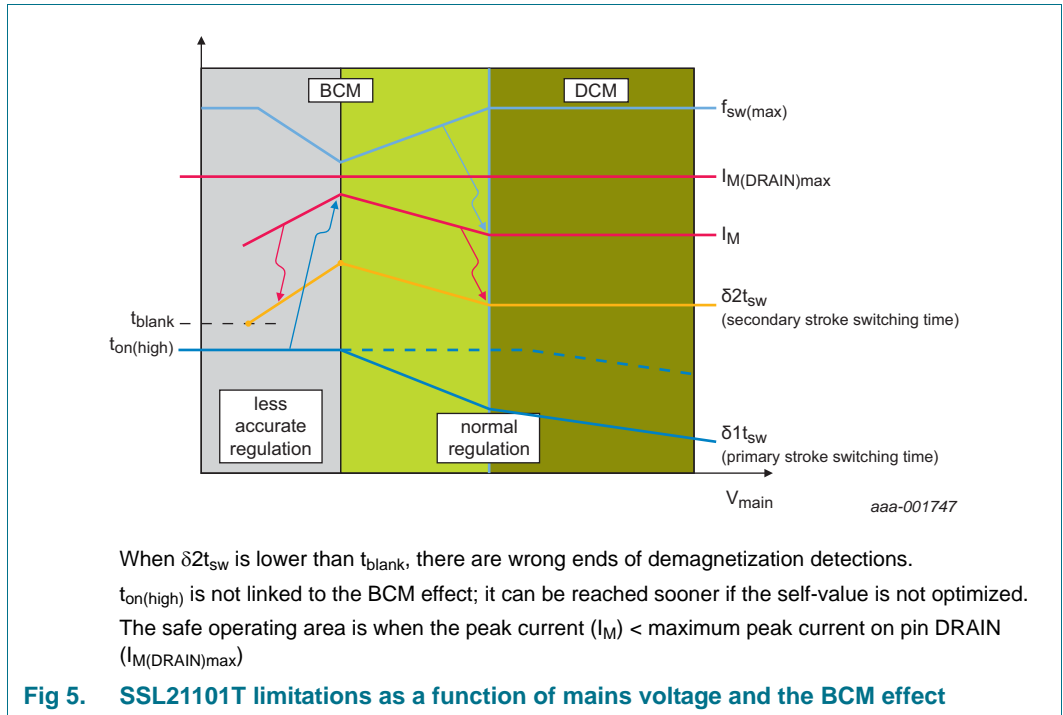

In BCM mode, the maximum frequency is not reached. The control first increases the peak current (I_M) and then the secondary stroke switching time ($\delta 2t_{sw}$) to maintain the output power. When the mains voltage decreases, $\delta 1t_{sw}$ increases. When $\delta 1t_{sw}$ reaches $t_{on(high)}$, the LED current is less accurate.

9. Limiting values

Table 7. Limiting values

In accordance with the Absolute Maximum Rating System (IEC 60134).

Symbol	Parameter	Conditions	Min	Max	Unit
General					
P_{tot}	total power dissipation		-	0.8	W
T_{stg}	storage temperature		-55	+150	°C
T_j	junction temperature		-40	+150	°C
V_{ESD}	electrostatic discharge voltage	Human Body Model (HBM)	[1]		
		pins DRAIN and V_{CC}	-1000	+1000	V
		all other pins	-2000	+2000	V
		Charged Device Model (CDM)	-500	+500	V
Voltages					
V_{CC}	supply voltage	continuous	-0.4	+40	V
$V_{DD(INTREGD)}$	internal regulated supply voltage		-0.4	+5.5	V
V_{RMAIN}	voltage on pin RMAIN		-0.4	+1.7	V
V_{SOURCE}	voltage on pin SOURCE		-0.4	+5.5	V
V_{DRAIN}	voltage on pin DRAIN		-0.4	+700	V
$V_{ILEDREF}$	voltage on pin ILEDREF		-0.4	+5.5	V
V_{MODE}	voltage on pin MODE		-0.4	+5.5	V
V_{NTC}	voltage on pin NTC		-0.4	+5.5	V
Currents					
$I_{M(SOURCE)}$	peak current on pin SOURCE		-1.2	0	A
$I_{M(DRAIN)}$	peak current on pin DRAIN		0	1.2	A
$I_{M(RMAIN)}$	peak current on pin RMAIN		0	450	μA

[1] Human body model: equivalent to discharging a 100 pF capacitor through a 1.5 kΩ series resistor.

10. Thermal characteristics

Table 8. Thermal characteristics

Symbol	Parameter	Conditions	Typ	Unit
$R_{th(j-a)}$	thermal resistance from junction to ambient	in free air; SO14 package; PCB: 906 mm ² ; 2-layer; 35 μm Cu/layer	70	K/W

[1] $R_{th(j-a)}$ can be lower when the GND pins are connected to an area with sufficient copper on the printed-circuit board.

11. Characteristics

Table 9. Characteristics
 $T_{amb} = 25\text{ °C}$

Symbol	Parameter	Conditions	Min	Typ	Max	Unit
Supply						
I_{CC}	supply current	pin V_{CC} ; $V_{DRAIN} > 60\text{ V}$; $V_{CC} = 22\text{ V}$; $T_j = 25\text{ °C}$	0.15	0.8	1.4	mA
V_{CC}	supply voltage	functional	13	22	25.5	V
$I_{CC(startup)}$	start-up supply current	pin V_{CC} ; $V_{DRAIN} > 60\text{ V}$; $V_{CC} = 15\text{ V}$; $T_j = 125\text{ °C}$	-	-	1.46	mA
$V_{CC(startup)}$	start-up supply voltage		15	17	19	V
$V_{CC(UVLO)}$	undervoltage lockout supply voltage		9.5	11	13	V
$I_{startup(DRAIN)}$	start-up current on pin DRAIN	$V_{DRAIN} > 60\text{ V}$; $V_{CC} = 14\text{ V}$; $T_j = 125\text{ °C}$	870	1200	1530	μA
		$V_{DRAIN} > 60\text{ V}$; $V_{CC} = 19\text{ V}$; $T_j = 125\text{ °C}$	500	700	900	μA
$V_{BR(DRAIN)}$	breakdown voltage on pin DRAIN		-	-	700	V
Output stage						
R_{DSon}	drain-source on-state resistance	$T_j = 25\text{ °C}$	-	6.8	-	Ω
		$T_j = 125\text{ °C}$	-	9.5	-	Ω
$(dV/dt)_r(DRAIN)$	rise rate of change voltage on pin DRAIN		-	6	-	V/ns
$(dV/dt)_f(DRAIN)$	fall rate of change voltage on pin DRAIN		-	3	-	V/ns
$t_{on(high)}$	high on-time	MOSFET on-time limitation; main = 50 Hz; mode = 50 kHz	15.8	16.7	17.6	μs
		main = 60 Hz; mode = 50 kHz	13.1	13.9	14.7	μs
		main = 50 Hz; mode = 100 kHz	7.9	8.55	9.3	μs
		main = 60 Hz; mode = 100 kHz	6.5	7.1	7.7	μs

Table 9. Characteristics ...continued

$T_{amb} = 25\text{ }^{\circ}\text{C}$

Symbol	Parameter	Conditions	Min	Typ	Max	Unit
$t_{prot(sc)LED}$	LED short-circuit protection time	secondary stroke switching time;				
		main = 50 Hz	33.8	35.8	37.7	μs
		main = 60 Hz	28.1	29.8	31.5	μs

Temperature protection

$T_{th(otp)}$	overtemperature protection threshold temperature	junction temperature	-	140	-	$^{\circ}\text{C}$
$T_{otp(hys)}$	overtemperature protection trip hysteresis	junction temperature	-	20	-	$^{\circ}\text{C}$

Regulator

$V_{DD(INTREGD)}$	internal regulated supply voltage		4.6	4.9	5.2	V
$V_{DD(rst)}$	reset supply voltage	power-on reset	-	-	4.55	V
$V_{prot(VCC)}$	protection voltage on pin VCC		25.5	28	31	V
$V_{th(det)SOURCE}$	detection threshold voltage on pin SOURCE		0.65	-	0.85	V
$V_{th(swp)SOURCE}$	short-winding protection threshold voltage on pin SOURCE		-	$1.5V_{th(det)SOURCE}$	-	V

Demagnetization

t_{blank}	blanking time	main = 50 Hz	2.56	2.85	3.14	μs
		main = 60 Hz	2.14	2.37	2.62	μs

Frequency switching

$f_{sw(max)}$	maximum switching frequency	DCM mode; [1] main = 50 Hz; mode = 50 kHz	49.7	51.2	52.7	kHz
		DCM -mode; [1] main = 60 Hz; mode = 50 kHz	59.7	61.4	63.2	kHz
		DCM mode; [1] main = 50 Hz; mode = 100 kHz	99.4	102.4	105.4	kHz
		DCM mode; [1] main = 60 Hz; mode = 100 kHz	119.4	122.9	126.4	kHz

Table 9. Characteristics ...continued

$T_{amb} = 25\text{ }^{\circ}\text{C}$

Symbol	Parameter	Conditions	Min	Typ	Max	Unit
True current source (current accuracy)						
ΔI_o	output current variation	main variation: +10 % to -15 %	-3	-	+3	%
		output voltage variation: $\pm 20\%$	-3	-	+3	%
		temperature variation: $\Delta T_j = 140\text{ }^{\circ}\text{C}$	-3	-	+3	%
		coil variation: $\pm 20\%$	-3	-	+3	%
NTC						
$V_{det(H)(NTC)}$	HIGH-level detection voltage on pin NTC		$0.23V_{DD(INTREGD)}$	$0.25V_{DD(INTREGD)}$	$0.27V_{DD(INTREGD)}$	V
$V_{det(L)(NTC)}$	LOW-level detection voltage on pin NTC		$0.115V_{DD(INTREGD)}$	$0.125V_{DD(INTREGD)}$	$0.135V_{DD(INTREGD)}$	V
I_{LED}/I_{LEDExp}	LED current to expected LED current ratio		[2] -	1	-	
I_{LEDmin}/I_{LEDExp}	minimum LED current to expected LED current ratio		[2] -	0.75	-	

[1] See [Table 5](#).

[2] See [Figure 4](#).

13. Package outline

SO14: plastic small outline package; 14 leads; body width 3.9 mm

SOT108-1

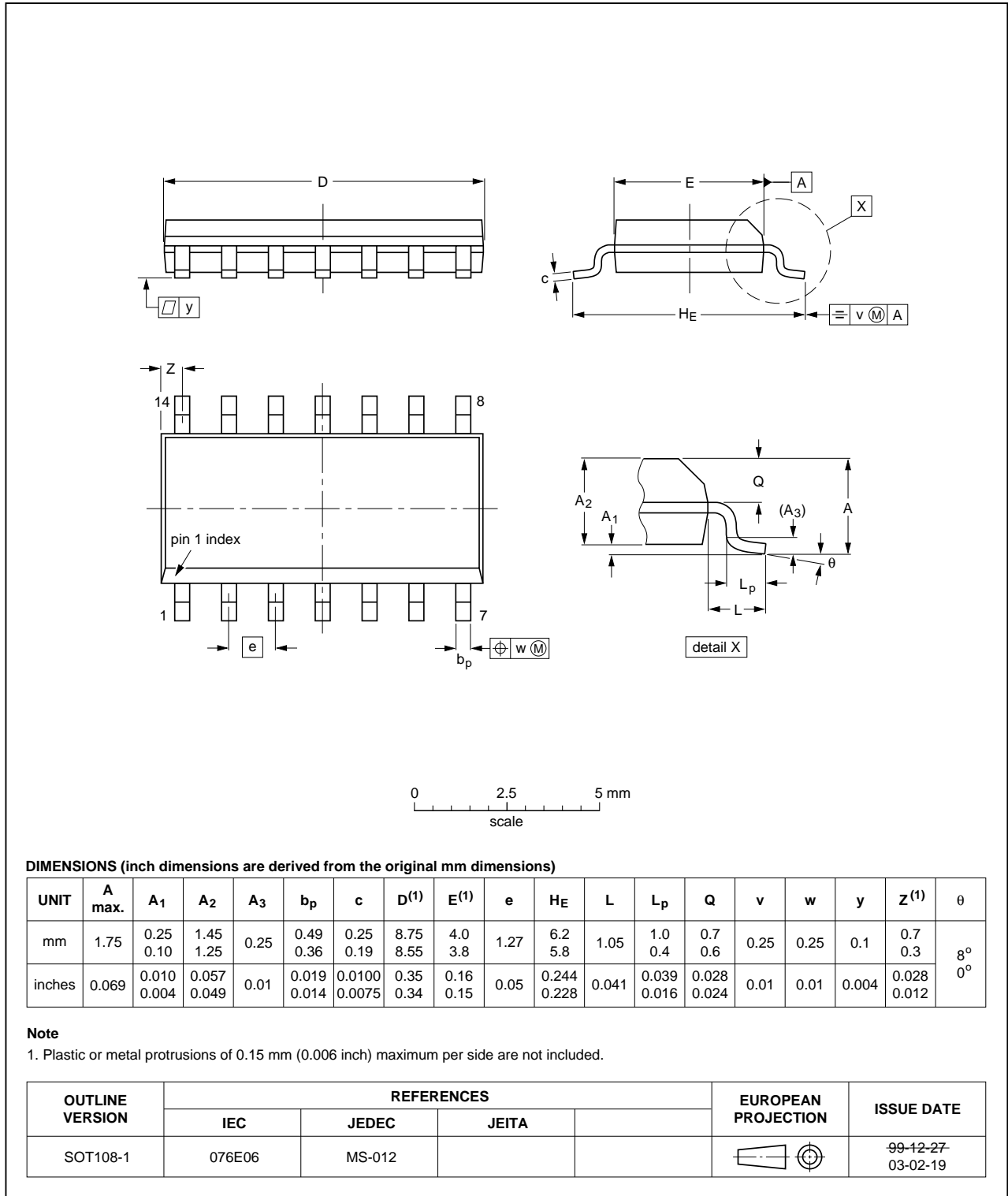

Fig 8. Package outline SOT108-1 (SO14)

14. Abbreviations

Table 10. Abbreviations

Acronym	Description
BCM	Boundary Conduction Mode
CCM	Continuous Conduction Mode
CDM	Charged Device Model
DCM	Discontinuous Conduction Mode
JFET	Junction Field-Effect Transistor
LEB	Leading-Edge Blanking
LED	Light-Emitting Diode
LR	Low Ripple
LTHD	Low Total Harmonic Distortion
NTC	Negative Temperature Coefficient
OTP	OverTemperature Protection
SMPS	Switched Mode Power Supply
SDC	Smart Digital Control
SSL	Solid-State Light
THD	Total Harmonic Distortion
UVLO	UnderVoltage LockOut

15. Revision history

Table 11. Revision history

Document ID	Release date	Data sheet status	Change notice	Supersedes
SSL21101T v.3	20120607	Product data sheet	-	SSL2110XT v.2
SSL21101T v.2	20120504	Objective data sheet	-	SSL2110XT v.1
SSL2110XT v.1	20110704	Objective data sheet	-	-

16. Legal information

16.1 Data sheet status

Document status ^{[1][2]}	Product status ^[3]	Definition
Objective [short] data sheet	Development	This document contains data from the objective specification for product development.
Preliminary [short] data sheet	Qualification	This document contains data from the preliminary specification.
Product [short] data sheet	Production	This document contains the product specification.

[1] Please consult the most recently issued document before initiating or completing a design.

[2] The term 'short data sheet' is explained in section "Definitions".

[3] The product status of device(s) described in this document may have changed since this document was published and may differ in case of multiple devices. The latest product status information is available on the Internet at URL <http://www.nxp.com>.

16.2 Definitions

Draft — The document is a draft version only. The content is still under internal review and subject to formal approval, which may result in modifications or additions. NXP Semiconductors does not give any representations or warranties as to the accuracy or completeness of information included herein and shall have no liability for the consequences of use of such information.

Short data sheet — A short data sheet is an extract from a full data sheet with the same product type number(s) and title. A short data sheet is intended for quick reference only and should not be relied upon to contain detailed and full information. For detailed and full information see the relevant full data sheet, which is available on request via the local NXP Semiconductors sales office. In case of any inconsistency or conflict with the short data sheet, the full data sheet shall prevail.

Product specification — The information and data provided in a Product data sheet shall define the specification of the product as agreed between NXP Semiconductors and its customer, unless NXP Semiconductors and customer have explicitly agreed otherwise in writing. In no event however, shall an agreement be valid in which the NXP Semiconductors product is deemed to offer functions and qualities beyond those described in the Product data sheet.

16.3 Disclaimers

Limited warranty and liability — Information in this document is believed to be accurate and reliable. However, NXP Semiconductors does not give any representations or warranties, expressed or implied, as to the accuracy or completeness of such information and shall have no liability for the consequences of use of such information. NXP Semiconductors takes no responsibility for the content in this document if provided by an information source outside of NXP Semiconductors.

In no event shall NXP Semiconductors be liable for any indirect, incidental, punitive, special or consequential damages (including - without limitation - lost profits, lost savings, business interruption, costs related to the removal or replacement of any products or rework charges) whether or not such damages are based on tort (including negligence), warranty, breach of contract or any other legal theory.

Notwithstanding any damages that customer might incur for any reason whatsoever, NXP Semiconductors' aggregate and cumulative liability towards customer for the products described herein shall be limited in accordance with the *Terms and conditions of commercial sale* of NXP Semiconductors.

Right to make changes — NXP Semiconductors reserves the right to make changes to information published in this document, including without limitation specifications and product descriptions, at any time and without notice. This document supersedes and replaces all information supplied prior to the publication hereof.

Suitability for use — NXP Semiconductors products are not designed, authorized or warranted to be suitable for use in life support, life-critical or safety-critical systems or equipment, nor in applications where failure or malfunction of an NXP Semiconductors product can reasonably be expected to result in personal injury, death or severe property or environmental damage. NXP Semiconductors and its suppliers accept no liability for inclusion and/or use of NXP Semiconductors products in such equipment or applications and therefore such inclusion and/or use is at the customer's own risk.

Applications — Applications that are described herein for any of these products are for illustrative purposes only. NXP Semiconductors makes no representation or warranty that such applications will be suitable for the specified use without further testing or modification.

Customers are responsible for the design and operation of their applications and products using NXP Semiconductors products, and NXP Semiconductors accepts no liability for any assistance with applications or customer product design. It is customer's sole responsibility to determine whether the NXP Semiconductors product is suitable and fit for the customer's applications and products planned, as well as for the planned application and use of customer's third party customer(s). Customers should provide appropriate design and operating safeguards to minimize the risks associated with their applications and products.

NXP Semiconductors does not accept any liability related to any default, damage, costs or problem which is based on any weakness or default in the customer's applications or products, or the application or use by customer's third party customer(s). Customer is responsible for doing all necessary testing for the customer's applications and products using NXP Semiconductors products in order to avoid a default of the applications and the products or of the application or use by customer's third party customer(s). NXP does not accept any liability in this respect.

Limiting values — Stress above one or more limiting values (as defined in the Absolute Maximum Ratings System of IEC 60134) will cause permanent damage to the device. Limiting values are stress ratings only and (proper) operation of the device at these or any other conditions above those given in the Recommended operating conditions section (if present) or the Characteristics sections of this document is not warranted. Constant or repeated exposure to limiting values will permanently and irreversibly affect the quality and reliability of the device.

Terms and conditions of commercial sale — NXP Semiconductors products are sold subject to the general terms and conditions of commercial sale, as published at <http://www.nxp.com/profile/terms>, unless otherwise agreed in a valid written individual agreement. In case an individual agreement is concluded only the terms and conditions of the respective agreement shall apply. NXP Semiconductors hereby expressly objects to applying the customer's general terms and conditions with regard to the purchase of NXP Semiconductors products by customer.

No offer to sell or license — Nothing in this document may be interpreted or construed as an offer to sell products that is open for acceptance or the grant, conveyance or implication of any license under any copyrights, patents or other industrial or intellectual property rights.

Export control — This document as well as the item(s) described herein may be subject to export control regulations. Export might require a prior authorization from competent authorities.

Quick reference data — The Quick reference data is an extract of the product data given in the Limiting values and Characteristics sections of this document, and as such is not complete, exhaustive or legally binding.

Non-automotive qualified products — Unless this data sheet expressly states that this specific NXP Semiconductors product is automotive qualified, the product is not suitable for automotive use. It is neither qualified nor tested in accordance with automotive testing or application requirements. NXP Semiconductors accepts no liability for inclusion and/or use of non-automotive qualified products in automotive equipment or applications.

In the event that customer uses the product for design-in and use in automotive applications to automotive specifications and standards, customer (a) shall use the product without NXP Semiconductors' warranty of the

product for such automotive applications, use and specifications, and (b) whenever customer uses the product for automotive applications beyond NXP Semiconductors' specifications such use shall be solely at customer's own risk, and (c) customer fully indemnifies NXP Semiconductors for any liability, damages or failed product claims resulting from customer design and use of the product for automotive applications beyond NXP Semiconductors' standard warranty and NXP Semiconductors' product specifications.

16.4 Trademarks

Notice: All referenced brands, product names, service names and trademarks are the property of their respective owners.

GreenChip — is a trademark of NXP B.V.

17. Contact information

For more information, please visit: <http://www.nxp.com>

For sales office addresses, please send an email to: salesaddresses@nxp.com

18. Contents

1	General description	1
2	Features and benefits	1
3	Applications	2
4	Quick reference data	2
5	Ordering information	2
6	Block diagram	3
7	Pinning information	3
7.1	Pinning	3
7.2	Pin description	4
8	Functional description	4
8.1	True current source behavior	5
8.2	Leading-Edge Blanking (LEB)	6
8.3	dV/dt detection	6
8.4	Secondary stroke switching time ($d2t_{sw}$)	6
8.5	Mains sensing	6
8.6	Modulation type versus MODE pin input	7
8.7	Supply concept: V_{CC} and UnderVoltage LockOut (UVLO)	7
8.8	Peak current detection	8
8.9	Overheating protection of the LEDs	8
8.10	Short-winding protection	9
8.11	Output LED short circuit protection	9
8.12	Output LED open circuit protection	9
8.13	Limitations	9
9	Limiting values	11
10	Thermal characteristics	11
11	Characteristics	12
12	Application information	15
13	Package outline	17
14	Abbreviations	18
15	Revision history	19
16	Legal information	20
16.1	Data sheet status	20
16.2	Definitions	20
16.3	Disclaimers	20
16.4	Trademarks	21
17	Contact information	21
18	Contents	22

Please be aware that important notices concerning this document and the product(s) described herein, have been included in section 'Legal information'.

© NXP B.V. 2012.

All rights reserved.

For more information, please visit: <http://www.nxp.com>

For sales office addresses, please send an email to: salesaddresses@nxp.com

Date of release: 7 June 2012

Document identifier: SSL21101T

Looking for pricing, stock, or lifecycle information?

Click below to explore more details on WIN SOURCE:

- ⊖ [View SSL21101T/1,518 on WIN SOURCE](#)
- ⊖ [NXP / Nexperia Information](#)

Optimize Your Supply Chain with WIN SOURCE Solutions

- ✓ Global Sourcing Solution
- ✓ Obsolete Management
- ✓ Cost Control Management
- ✓ Shortage Management
- ✓ Alternative Solution
- ✓ Excess Inventory Management