



**THE DATASHEET OF
STP1612PW05TTR**





STP1612PW05

16-channel LED driver with 16-bit PWM,
8-bit gain and full LED error detection

Preliminary data

Features

- 16 constant current output channels
- Supply voltage: 3.3 V or 5 V
- Two PWM selectable counters 12/16-bit of grayscale
- Selectable enhanced PWM for ghost effect reduction
- Open and short LED detection
- 8-bit current gain control by means of 256 steps in two selectable ranges
- Single resistor to set the current from 3 mA to 60 mA
- Programmable progressive output delay
- Thermal protection and thermal flag
- UVLO
- Schmitt trigger input
- Selectable 16-bit or 256-bit serial data-in format
- Max clock frequency: 30 MHz
- ESD protection 2.5 kV HBM, 200 V MM
- Drop-in compatible with STP16CP\S\SDP05 series
- Available in high thermal efficiency TSSOP exposed pad

Applications

- Video display LED panels
- RGB backlighting
- Special lighting

Table 1. Device summary

Order code	Package	Packaging
STP1612PW05QTR	QFN-24	4000 parts per reel
STP1612PW05MTR	SO-24	1000 parts per reel
STP1612PW05TTR	TSSOP24	2500 parts per reel
STP1612PW05XTTR	TSSOP24 exposed pad	2500 parts per reel

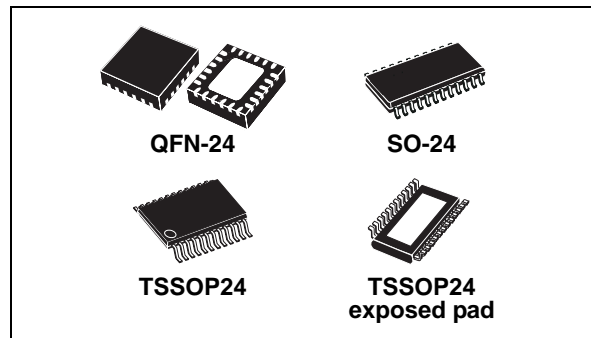

Description

The STP1612PW05 is a 16-channel constant current sink LED driver. The maximum output current value for all the 16 channels is set by a single resistor from 3 mA to 60 mA. The device features 8-bit gain (256 steps) for global LED brightness adjustment with two selectable ranges. This function is accessible via a serial interface. The device has an individual adjustable PWM brightness control for each output channel. The PWM counters are selectable via a serial interface with 4096 or 65536 steps (12 or 16 bit). The STP1612PW05 also provides enhanced pulse-width modulation counting algorithms called e-PWM to reduce flickering effects (ghost visual effects) improving the overall image quality. The device has a dual size 16-bit or 256-bit shift register. All the control and the shift register read back data are accessible via serial interface. The STP1612PW05 has the capability to detect open and short LED failure and overtemperature, reporting the status through SPI line. The device guarantees a 20 V output driving capability, allowing the user to connect more LEDs in series.

Contents

- 1 Block diagram 4**
- 2 Summary description 5**
 - 2.1 Pin connection and description 6
- 3 Electrical ratings 7**
 - 3.1 Absolute maximum ratings 7
 - 3.2 Thermal data 7
 - 3.3 Recommended operating conditions 8
- 4 Electrical characteristics 9**
- 5 Timing waveform 13**
- 6 Principle of operation 14**
- 7 Configuration register 16**
- 8 Grey scales data loading 17**
- 9 Setting the PWM gray scale counter 18**
 - 9.1 PWM data synchronization 18
 - 9.2 Synchronization for PWM counting 19
- 10 Error detection conditions 20**
- 11 Setting output current 22**
- 12 Constant current 23**
- 13 Current gain adjustment 24**
- 14 Delay time of staggered output 25**
- 15 Thermal protection 25**

16	Time-out alert of GCLK disconnection	26
17	Application information	27
	17.1 LED supply voltage (VLED)	27
	17.2 Setting grayscale brightness	29
	17.3 Multi device application	30
18	Package mechanical data	31
19	Revision history	40

1 Block diagram

Figure 1. Block diagram

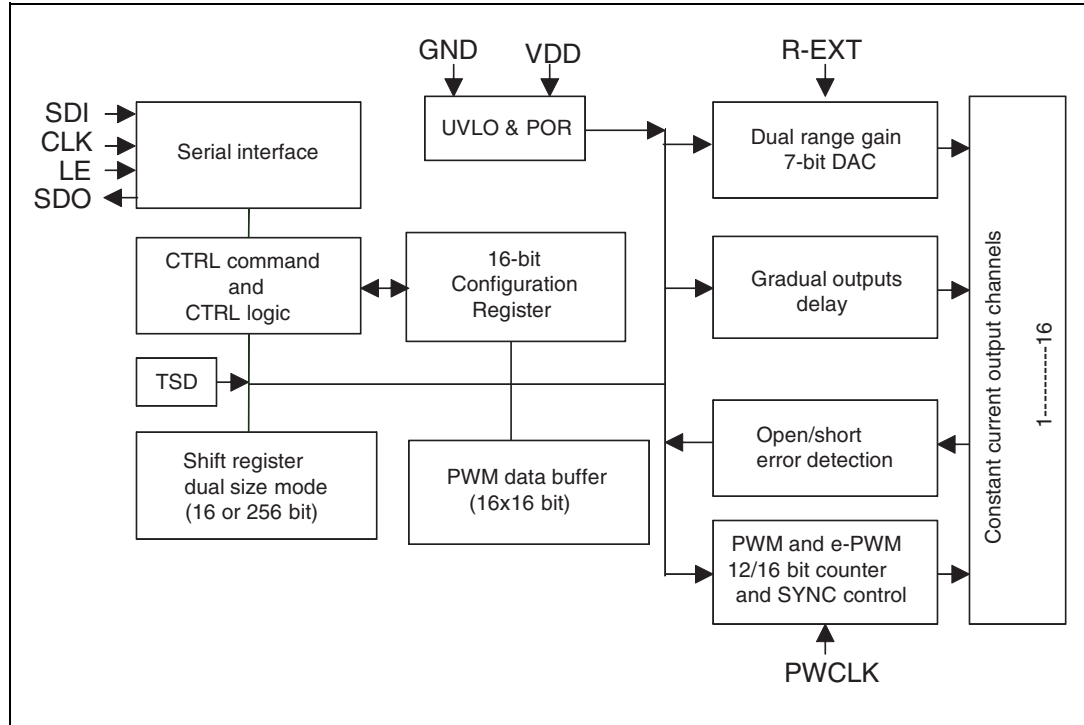

2 Summary description

Table 2. Typical current accuracy at 5 V

Output voltage	Current accuracy	Output current	V _{DD}	temp.
	Between ICs			
≥ 1.0	± 6%	15 to 60	5 V	25 °C
≥ 0,2	± 6%	3 to 15		

Table 3. Typical current accuracy at 3.3 V

Output voltage	Current accuracy	Output current	V _{DD}	temp.
	Between ICs			
≥ 1.0	± 6%	15 to 60	3.3 V	25 °C
≥ 0,3	± 6%	3 to 15		

2.1 Pin connection and description

Figure 2. Pin connection

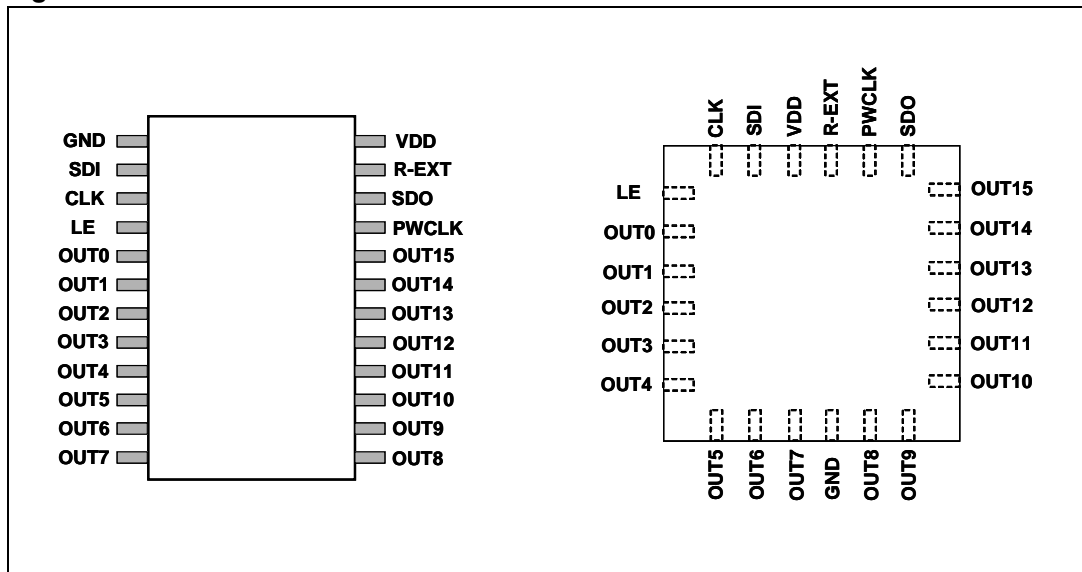

Note: The exposed pad should be electrically connected to a metal land electrically isolated or connected to ground

Table 4. Pin description

Pin n°	Symbol	Name and function
1	GND	Ground terminal
2	SDI	Serial data input terminal
3	CLK	Clock input terminal used to shift data on rising edge and carries command information when LE is asserted.
4	LE	Data strobe terminal and controlling command with CLK
5-20	OUT 0-15	Output terminals
21	PWCLK	Gray scale clock terminal. Reference clock for grey scale PWM counter.
22	SDO	Serial data out terminal
23	R-EXT	Input terminal of an external resistor for constant current programming
24	V _{DD}	Supply voltage terminal

3 Electrical ratings

3.1 Absolute maximum ratings

Stressing the device above the rating listed in the [Table 5](#) may cause permanent damage to the device. These are stress ratings only and operation of the device at these or any other conditions above those indicated in the operating sections of this specification is not implied. Exposure to absolute maximum rating conditions for extended periods may affect device reliability.

Table 5. Absolute maximum ratings

Symbol	Parameter	Value	Unit
V_{DD}	Supply voltage	0 to 7	V
V_O	Output voltage	-0.5 to 20	V
I_O	Output current	60	mA
V_I	Input voltage	-0.4 to V_{DD}	V
I_{GND}	GND terminal current	1300	mA
f_{CLK}	Clock frequency	50	MHz
T_J	Junction temperature range ⁽¹⁾	-40 to +170	°C

1. Such absolute value is based on the thermal shutdown protection.

3.2 Thermal data

Table 6. Thermal data

Symbol	Parameter	Value	Unit	
T_A	Operating free-air temperature range	-40 to +125	°C	
T_{J-OPR}	Operating thermal junction temperature range	-40 to +150	°C	
T_{STG}	Storage temperature range	-55 to +150	°C	
R_{thJA}	Thermal resistance junction-ambient ⁽¹⁾	SO-24	42.7	°C/W
		TSSOP24	55	°C/W
		TSSOP24 ⁽²⁾ Exposed pad	37.5	°C/W
		QFN-24	55	°C/W

1. According to Jedec standard 51-7B

2. The exposed pad should be soldered directly to the PCB to realize the thermal benefits.

3.3 Recommended operating conditions

Table 7. Recommended operating conditions at 25 °C

Symbol	Parameter	Test conditions	Min.	Typ.	Max.	Unit
V_{DD}	Supply voltage		3.0	-	5.5	V
V_O	Output voltage			-	20	V
I_O	Output current, OUTn		3	-	60	mA
$I_{OH,SDO}$	Output current, SDO			-	+1	mA
$I_{OL,SDO}$	Output current, SDO			-	-1	mA
V_{IH}	Input voltage		$0.7 V_{DD}$	-	V_{DD}	V
V_{IL}	Input voltage		GND	-	$0.3 V_{DD}$	V
t_{wLAT}	LE pulse width	$V_{DD} = 3.3 \text{ V to } 5.0 \text{ V}$	20	-		ns
t_{wCLK}	CLK pulse width		10	-		ns
t_{wEN}	PWCLK pulse width		20	-		ns
$t_{SETUP(D)}$	Setup time for DATA		5	-		ns
$t_{HOLD(D)}$	Hold time for DATA		5	-		ns
$t_{SETUP(L)}$	Setup time for LATCH		5	-		ns
f_{CLK}	Clock frequency	Cascade operation ⁽¹⁾		-	30	MHz

1. If the device is connected in cascade, it may not be possible to achieve the maximum data transfer. Please consider the timings carefully.

4 Electrical characteristics

$V_{DD} = 3.3\text{ V} \pm 10\%$, $V_{DD} = 5\text{ V} \pm 10\%$, $T_A = 25\text{ }^\circ\text{C}$ unless otherwise specified

Table 8. Electrical characteristics

Symbol	Characteristics	Test conditions	Min.	Typ.	Max.	Unit
V_O	Maximum output voltage	$\overline{\text{OUT0}} \sim \overline{\text{OUT15}}$			20	V
I_{OUT}	Output current	OUT0~OUT115	$V_O = 2\text{V}$	3	60	mA
$I_{\text{OH,SDO}}$		SDO			-8	
$I_{\text{OL,SDO}}$		SDO			8	
V_{IH}	Input voltage "H" level		$0.7 * V_{DD}$		V_{DD}	V
V_{IL}	Input voltage "L" level		GND		$0.3 * V_{DD}$	V
I_{OH}	Output leakage current	$V_O = 20\text{ V}$			1	μA
V_{OL}	Output voltage SDO	$I_{\text{OL}} = +8\text{ mA}$			0.4	V
V_{OH}		$I_{\text{OH}} = -8\text{ mA}$	$V_{DD} - 0.4$			V
dI_{OUT1}	Current skew (channel)	$I_{\text{OUT}} = 3\text{ mA}$, $V_O = 0.3\text{V}$, $R_{\text{EXT}} = 238.2\text{ k}\Omega$		± 1.5	± 3	%
dI_{OUT1}		$I_{\text{OUT}} = 20\text{ mA}$, $V_O = 1\text{V}$, $R_{\text{EXT}} = 34.7\text{ k}\Omega$				
dI_{OUT2}	Current skew (IC)	$I_{\text{OUT}} = 3\text{ mA}$, $V_O = 0.3\text{V}$, $R_{\text{EXT}} = 238.2\text{ k}\Omega$		± 3	± 6	%
dI_{OUT2}		$I_{\text{OUT}} = 20\text{ mA}$, $V_O = 1\text{V}$, $R_{\text{EXT}} = 34.7\text{ k}\Omega$				
$\%/dV_O$	Output current vs. output voltage regulation	V_O within 1.0 V and 3.0 V, $R_{\text{ext}} = 34.7\text{ k}\Omega$ @ 20 mA		± 0.1	± 0.5	% / V
$\%/dV_{DD}$	Output current vs. supply voltage regulation	V_{DD} within 4.5 V and 5.5 V		± 1.0	± 5.0	% / V
$R_{\text{IN(down)}}$	Pull-down resistor	LE	150	200	250	$\text{k}\Omega$
$I_{\text{DD(off) 1}}$	Supply current "Off"	$R_{\text{ext}} = \text{Open}$, $\overline{\text{OUT0}} \sim \overline{\text{OUT15}} = \text{Off}$		8	11	mA
$I_{\text{DD(off) 2}}$		$I_O = 3\text{ mA}$, $\overline{\text{OUT0}} \sim \overline{\text{OUT15}} = \text{Off}$		8.5	11	
$I_{\text{DD(off) 3}}$		$I_O = 60\text{ mA}$, $\overline{\text{OUT0}} \sim \overline{\text{OUT15}} = \text{Off}$		11	15	
$I_{\text{DD(on) 1}}$	Supply current "On"	$I_O = 3\text{ mA}$, $\overline{\text{OUT0}} \sim \overline{\text{OUT15}} = \text{On}$		8	11.5	mA
$I_{\text{DD(on) 2}}$		$I_O = 60\text{ mA}$, $\overline{\text{OUT0}} \sim \overline{\text{OUT15}} = \text{On}$		11.5	15	

Figure 3. Test circuit for electrical characteristics

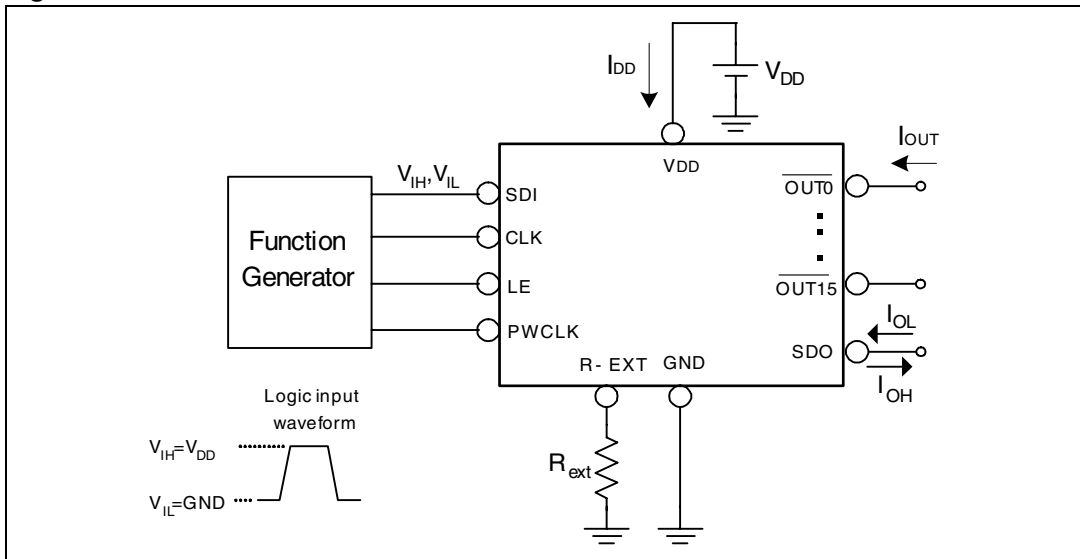

Table 9. Switching characteristics ($V_{DD} = 5.0\text{ V}$) $T_A = -40 \sim 125\text{ }^\circ\text{C}$

Symbol	Characteristics	Conditions	Min.	Typ.	Max.	Unit
t_{SU0}	Setup time	SDI - CLK \uparrow	1			ns
t_{SU1}		LE \uparrow - DCLK \uparrow	1			ns
t_{SU2}		LE \downarrow - DCLK \uparrow	5			ns
t_{H0}	Hold time	CLK \uparrow - SDI	3			ns
t_{H1}		CLK \uparrow - LE \downarrow	7			ns
t_{PD0}	Propagation delay time	CLK - SDO		30	40	ns
t_{PD1}		PWCLK-OUTn4 ⁽¹⁾		100		ns
t_{PD2}		LE - SDO ⁽²⁾		30	40	ns
t_{DL1}	Stagger delay time	$\overline{\text{OUTn4}} + 1$ ⁽¹⁾		40		ns
t_{DL2}		$\overline{\text{OUTn4}} + 2$ ⁽¹⁾		80		ns
t_{DL3}		$\overline{\text{OUTn4}} + 3$ ⁽¹⁾		120		ns
$t_{w(L)}$	Pulse width	LE	5			ns
$t_{w(\text{CLK})}$		CLK	20			ns
$t_{w(\text{PWCLK})}$		PWCLK	20			ns
t_{ON}	Output rise time of output ports			10		ns
t_{OFF}	Output fall time of output ports			6		ns
t_{EDD}	Error detection minimum duration ⁽³⁾			1		μs

1. Refer to the timing waveform, where $n = 0, 1, 2, 3$.

2. In timing of "read configuration" and "read error status code", the next CLK rising edge should be t_{PD2} after the falling edge of LE.

3. Refer to [Figure 5 on page 13](#).

Table 10. Switching characteristics ($V_{DD} = 3.3\text{ V}$)

Symbol	Characteristics	Conditions	Min.	Typ.	Max.	Unit	
t_{SU0}	Setup time	SDI - DCLK \uparrow	1			ns	
t_{SU1}		LE \uparrow - DCLK \uparrow	1			ns	
t_{SU2}		LE \downarrow - DCLK \uparrow	5			ns	
t_{H0}	Hold time	CLK \uparrow - SDI	3			ns	
t_{H1}		CLK \uparrow - LE \downarrow	7			ns	
t_{PD0}	Propagation delay time	CLK - SDO		45	40	ns	
t_{PD1}		PWCLK- $\overline{\text{OUTn4}}$ ⁽¹⁾	$V_{DD} = 3.3\text{ V}$ $V_{IH} = V_{DD}$ $V_{IL} = \text{GND}$		120		ns
t_{PD2}		LE - SDO ⁽²⁾	$R_{\text{ext}} = 460\ \Omega$		45	40	ns
t_{DL1}	Stagger delay time	$\overline{\text{OUTn4}} + 1$ ⁽¹⁾		40		ns	
t_{DL2}		$\overline{\text{OUTn4}} + 2$ ⁽¹⁾	$V_{\text{LED}} = 4.5\text{ V}$ $R_L = 152\ \Omega$ $C_L = 10\ \text{pF}$		80		ns
t_{DL3}		$\overline{\text{OUTn4}} + 3$ ⁽¹⁾	$C_1 = 100\ \text{nF}$ $C_2 = 10\ \mu\text{F}$		120		ns
$t_{w(L)}$	Pulse width	LE	5			ns	
$t_{w(\text{CLK})}$		CLK	20			ns	
$t_{w(\text{PWCLK})}$		PWCLK	20			ns	
t_{ON}	Output rise time of output ports			11.6		ns	
t_{OFF}	Output fall time of output ports			7		ns	
t_{DEC}	Error detection duration			0.5	1	μs	

1. Refer to the timing waveform [Figure 4](#), where n = 0, 1, 2, 3.
2. In timing of “read configuration” and “read error status code”, the next CLK rising edge should be t_{PD2} after the falling edge of LE.

Figure 4. Test circuit for switching characteristics

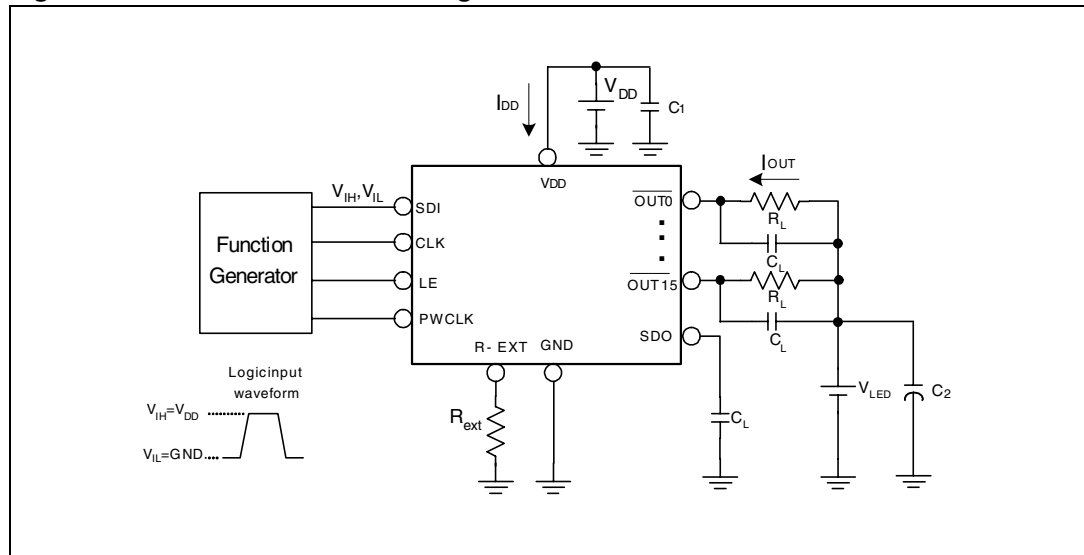

5 Timing waveform

Figure 5. Timing waveform

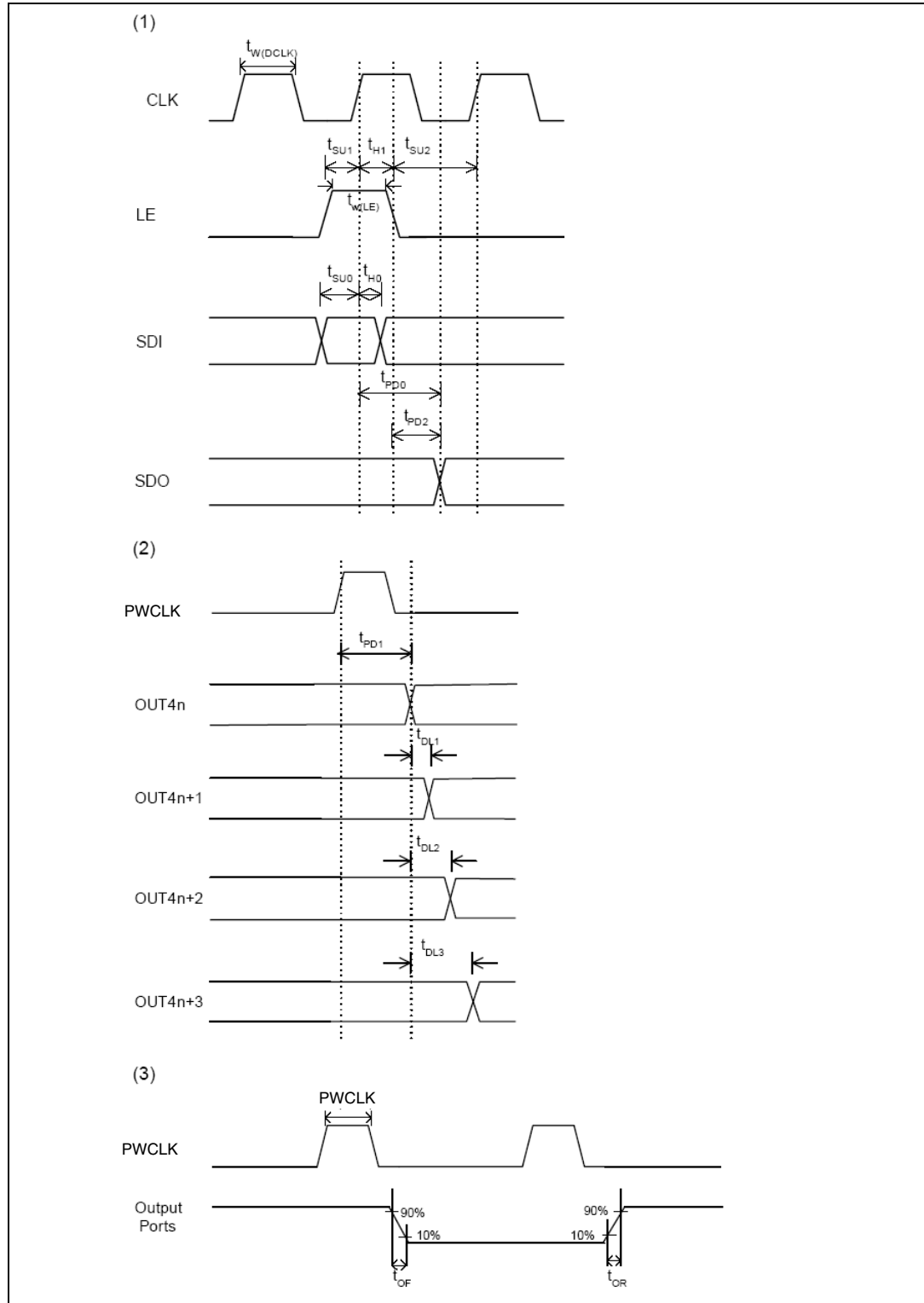

6 Principle of operation

Table 11. Control command

Command name	Signals combination		Description
	LE	Number of CLK rising edge when LE is asserted	
Data latch	High	1	Serial data are transferred to the buffers
Global latch	High	2 or 3	Buffer data are transferred to the comparators
Read configuration	High	4 or 5	Move out "configuration register" to the shift register
Enable "error detection"	High	6 or 7	Detect the status of each output's LED
Read "error status code"	High	8 or 9	Move out "error status code" of 16 outputs to the shift registers
Write configuration	High	10 or 11	Serial data are transferred to the "configuration register"
Reset to 16-bit shift register length	High	12 or 13	Set to 16-bit the shift register length

Figure 6. Timing diagram

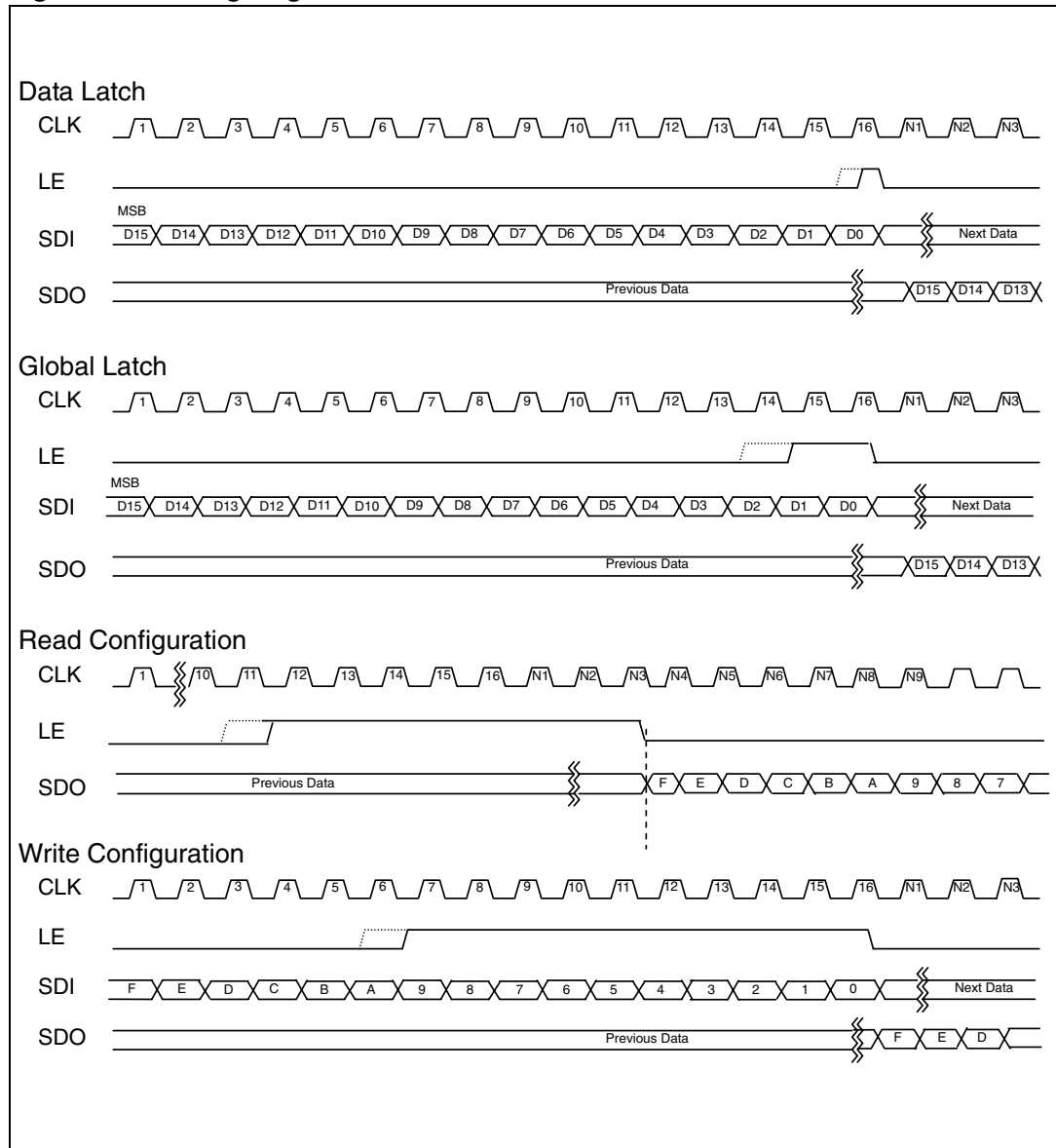

7 Configuration register

Table 12. Configuration register

Bit	Attribute	Definition	Value	Function	Default value
15	Read/Write	Shift register length	0	16 bit shift register	0
			1	256 bit shift register	
14	Read	Thermal error flag	0	Temperature OK	0
			1	Over temperature (>150°C typ.)	
13	Read/Write	PWM counter (12/16 bit)	0	12 bit Grayscale PWM counter	0
			1	16 bit Grayscale PWM counter	
12-11	Read/Write	PWM counting mode selection	00	64 times of MSB ⁽¹⁾ 6-bit PWM counting plus once of LSB ⁽¹⁾ 6-bit PWM	11
			01	16 times of MSB 6-bit PWM counting by 1/4 PWCLK plus once of LSB 6-bit PWM counting	
			10	4 times of MSB 6-bit PWM counting by 1/16 PWCLK plus once of LSB 6-bit PWM counting	
			11	PWM counting	
10	Read/Write	PWM data synchronization mode	0	Auto-synchronization	1
			1	Manual synchronization	
9-2	Read/Write	Current gain adjustment	00000000 ~ 11111111	Adjust the current value set by R-EXT over 256 steps	8b 10101011
1	Read/Write	Thermal Shutdown function	0	Disable	0
			1	Enable ⁽²⁾ (output channels OFF if temperature overcomes 150°C)	
0	Read/Write	Time-out alert for PWCLK disconnection	0	Enable ⁽³⁾	0
			1	Disable	

1. Please refer to “setting the PWM counting mode” section.
2. Please refer to “TSD” thermal error flag and thermal shutdown “section.
3. Please refer to “time-out alert of PWCLK disconnection” section.

8 Grey scales data loading

The STP1612PW05 is able to manage a gray-scale depth of 12 or 16 bits for each output, exploiting an e-PWM algorithm.

The bit D of the configuration register is used to select the grey-scale loading. Its value can be set to "0" for 12 bits or "1" for 16 bits. By default, D is set to "0".

Loading of the data is performed through the serial input on a dedicated buffer and two different methods can be used.

With both methods, the first incoming data packet is relative to the output 15; the following packet is relative to the output 14 and so on up to the output 0.

If F="0", when a data packet has been loaded, the latch signal (LE) must become active for one CLK cycle (data latch). When the last data packet, relative to the output 0, has been loaded, the latch signal must be active for two CLK cycles (global latch) and all the data will be transferred to the e-PWM registers starting from the MSB.

If F="1" all data packets (12 or 16 bits x16) are loaded and then the global latch signal must be active and all the data will be transferred to the e-PWM registers starting from the MSB.

Figure 7. Full timing for data loading

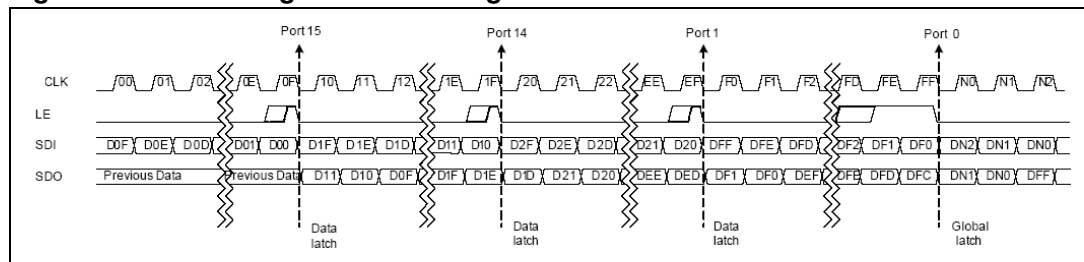

9 Setting the PWM gray scale counter

STP1612PW05 provides a 12-bit or 16-bit PWM color depth. Each serial data input will be implemented according to the e-PWM algorithm.

9.1 PWM data synchronization

STP1612PW05 defines the different counting algorithms that support e-PWM, technology, (scrambled PWM). With e-PWM, the total PWM cycles can be broken down into MSB (most significant bits) and LSB (least significant bits) of gray scale cycles, and the MSB information can be dithered across many refresh cycles to achieve overall same high bit resolution. STP1612PW05 also allows changing different counting algorithms and provides the best output linearity when there are fewer transitions of output.

Figure 8. 12-bit e-PWM operation example

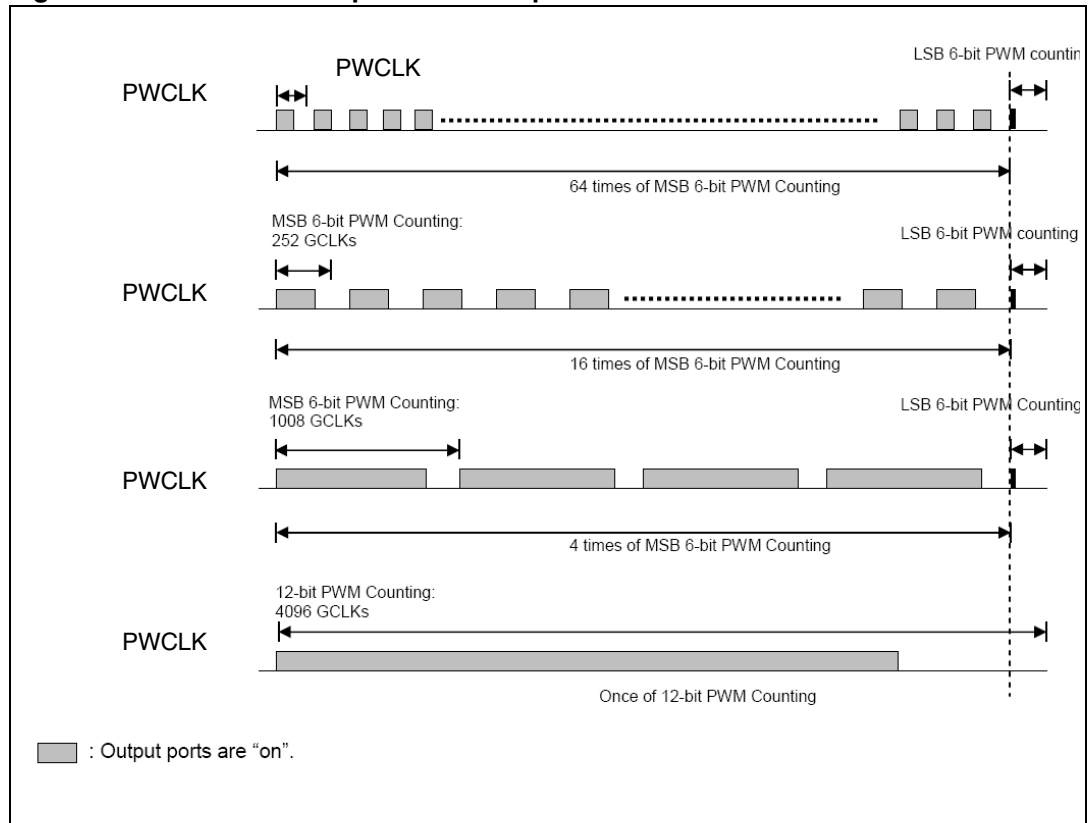

9.2 Synchronization for PWM counting

The data synchronization between the incoming data flow and the output channels is managed through the bit A within the configuration register.

If the bit A is set to “0” the device performs itself the data synchronization: when all the new data are loaded with a “global latch”, the device wait until all the PWM counter completes the counting cycle before updating them with the new data, at the next CLK rising edge.

Conversely, if bit A is set to “1” (default), the data synchronization is not performed by the device and is managed by the microcontroller, which has to take care of the data and signals. If this is not done, there might be artefacts on the output image.

Figure 9. Synchronization for PWM counting

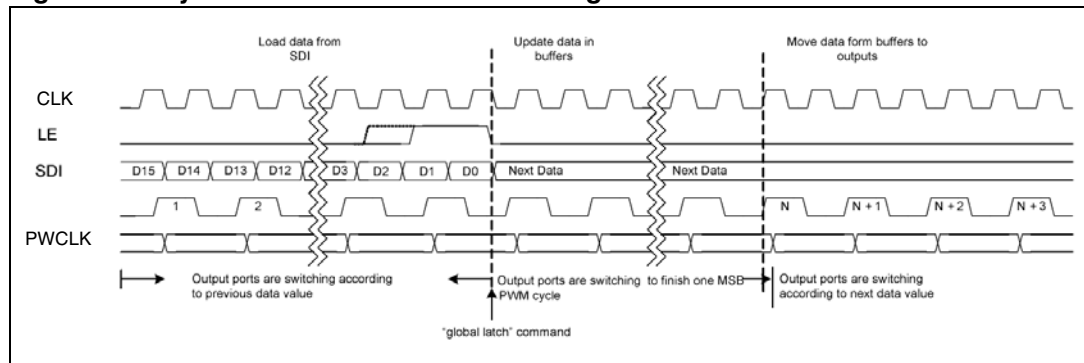
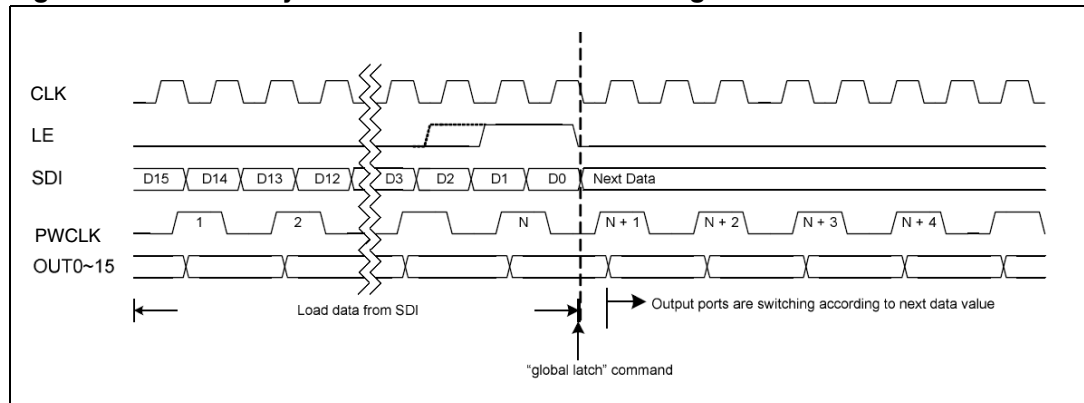

Figure 10. Without synchronization for PWM counting



10 Error detection conditions

The STP1612PW05 can detect open channels (OD) and LED short-circuits (SD).

The detection circuitry performs open- and short-circuit detection simultaneously and needs that all channels must be on. However the short test duration (0.5 μs typ) does not impact the image quality.

According to [Table 11](#), the command “Enable Error Detection” starts the diagnostic process. After 0.5 μs (typ) the faults detection has already been carried out and, through the command “Read Error Status Code”, the status is available on the serial output (SDO).

A bit set to "1" in the Error Status Code represents a channel considered good, whereas a "0" represents a failed output (open/short).

[Figure 11](#) describes the error detection process.

Figure 11. Error detection process

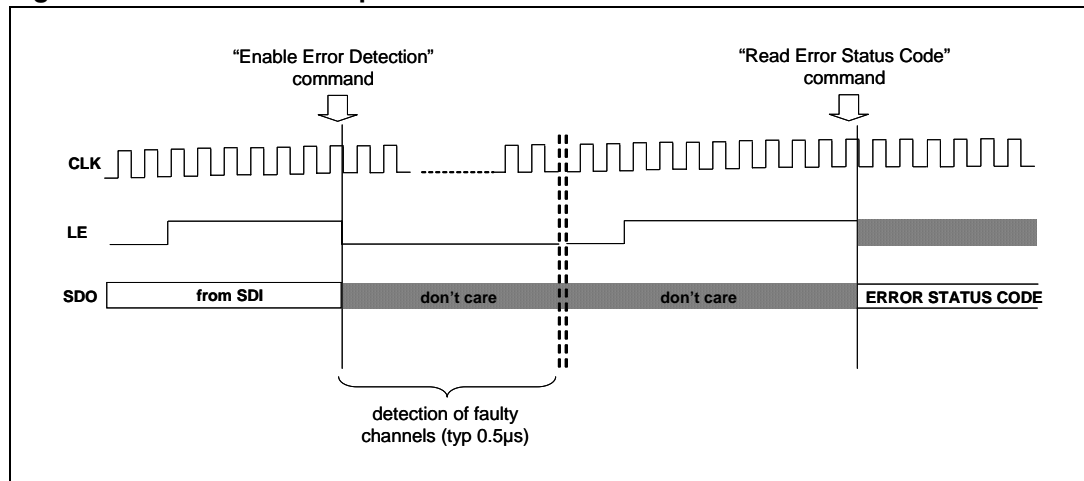

The [Table 13](#) and [Figure 12](#) explains the fault conditions detected by the diagnostic circuitry and how the detection is performed.

Table 13. Detection conditions (V_{DD} = 3.3 to 5 V temp. range -40 to 125 °C)

SW-1 or SW-3b	Open line or output short to GND detected	==> I _{ODEC} ≤ 0.5 x I _O
SW-2 or SW-3a	Short on LED or short to V-LED detected	==> V _O ≥ 2.3 V

Note: Where: I_O = the output current programmed by the R_{EXT}, I_{ODEC} = the detected output current in detection mode

Figure 12. Detection circuit

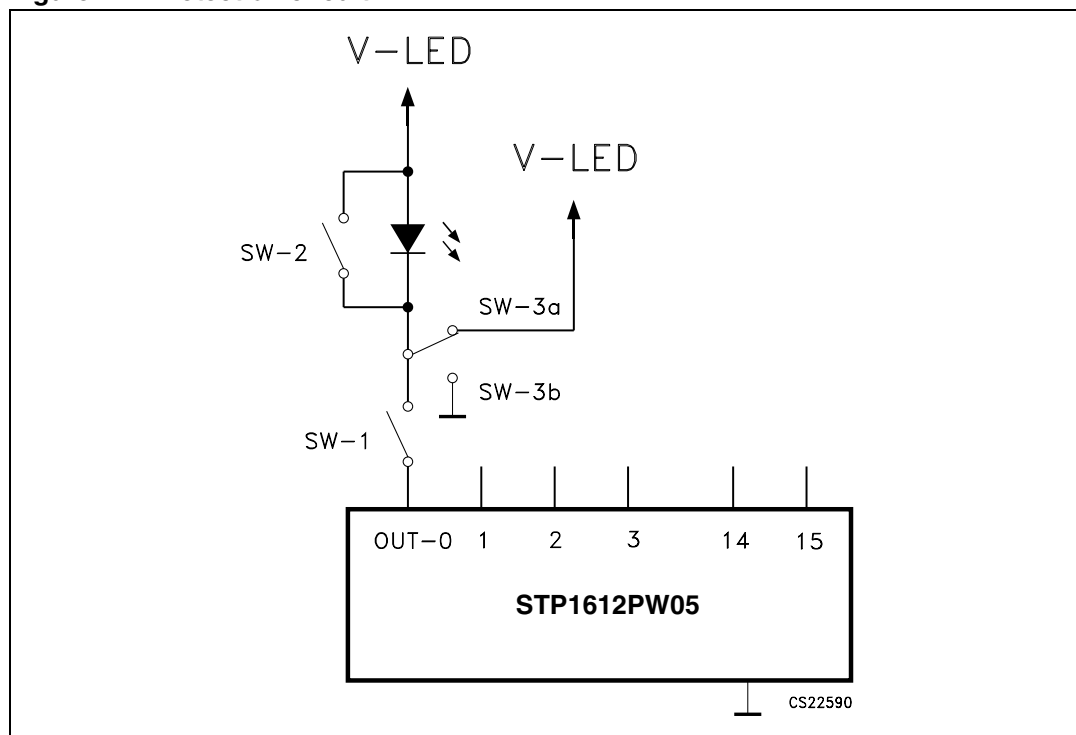

11 Setting output current

The output current (I_{OUT}) is set by an external resistor, R_{EXT} .

It is calculated from the equation:

$$V_{R-EXT} = 1.24 \times G; I_{OUT} = (V_{R-EXT}/R_{EXT}) \times 560$$

Whereas R_{EXT} is the resistance of the external resistor connected to R-EXT terminal and V_{R-EXT} is its voltage. G is the digital current gain, which is set by the bit9 – bit2 of the configuration register. The default value of G is 1. For your information, the output current is about 20 mA when $R_{EXT} = 34.70 \text{ k}\Omega$ and 10 mA when $R_{EXT} = 69.6 \text{ k}\Omega$ if G is set to default value 1. The formula and setting for G are described in next section.

Figure 13. Rext vs output current

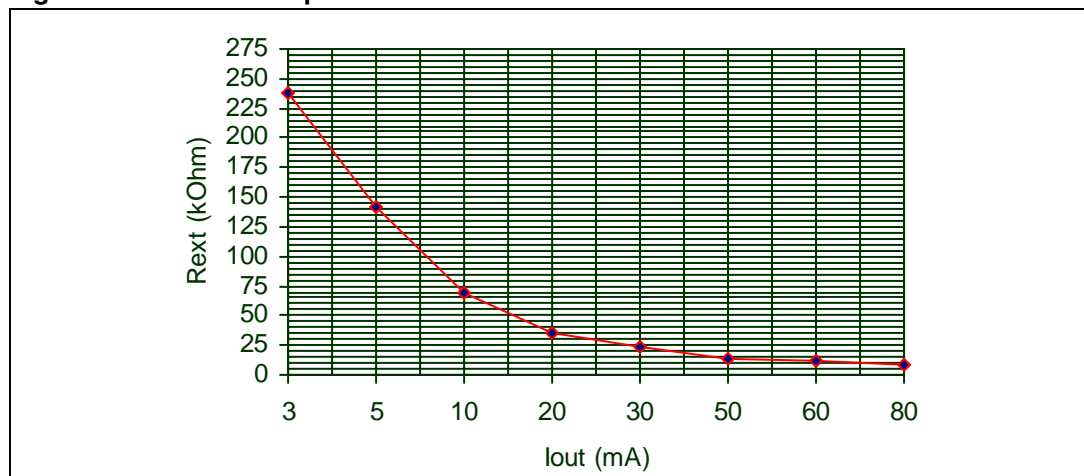

Table 14. Rext vs output current (1)

Iout (mA)	Rext (kΩ)
3	238.2
5	142.2
10	69.6
20	34.70
30	22.94
50	13.72
60	11.40
80	8.63

1. $T_A = 25 \text{ }^\circ\text{C}$, $V_{dd} = 3.3 \text{ V}; 5.0 \text{ V}$, $V_{Led} = 3.0 \text{ V}$, $V_{drop} = 1.5 \text{ V}$, HC = 0101011 (default)

12 Constant current

The STP1612PW05 assures nearly no variation in current both from channel to channel and from IC to IC.

The typical variation of the current between channels of the same IC is $\pm 1.5\%$, whereas the variation between ICs is around $\pm 3\%$.

Moreover the current characteristic of the output stage is flat (see [Figure 14](#) and [Figure 15](#)). This contributes to keep the current constant regardless of the variation of the LEDs forward voltage (V_F) and consequently guarantees uniformity of brightness.

Figure 14. I_{OUT} vs voltage drop across current generators (3.3 V supply voltage)

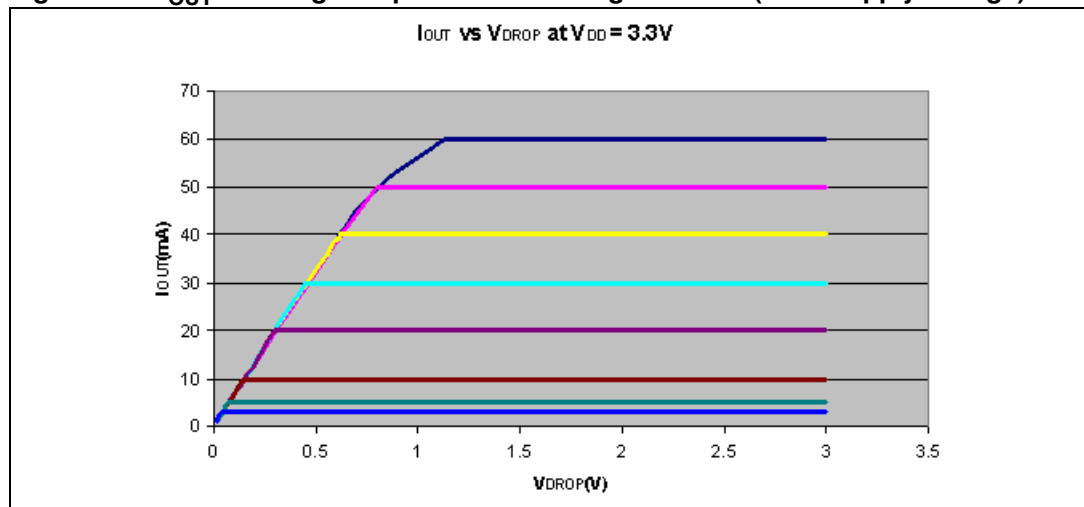
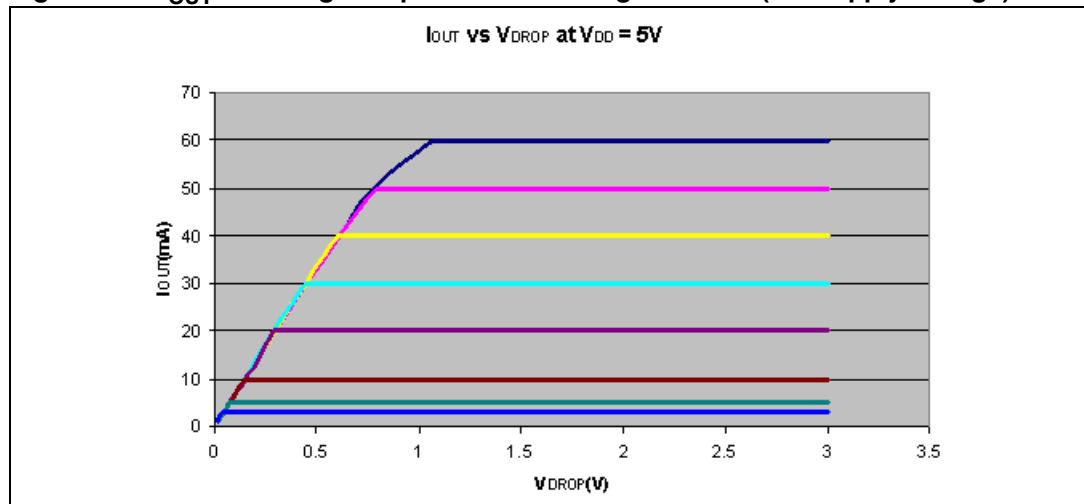

Figure 15. I_{OUT} vs voltage drop across current generators (5 V supply voltage)



The typical characteristics in [Figure 14](#) and [Figure 15](#) also show the minimum voltage drop required to assure that the current generators regulate the desired current.

This must be taken into account when choosing the suitable value of the LED supply voltage (see dedicated section).

13 Current gain adjustment

Figure 16. Gain vs DA6 - DA0

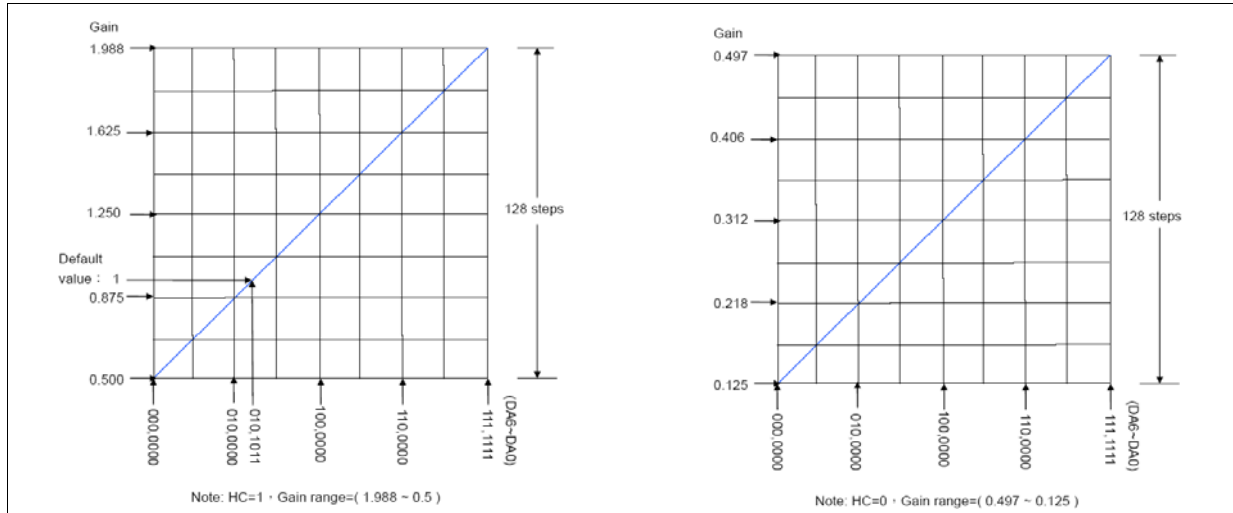

The bit 9 to bit 2 of the configuration register set the gain of output current, i.e., G. Being 8-bit in total, ranging from 8'b00000000 to 8'b11111111, these bits allow the user to set the output current gain up to 256 levels. These bits can be further defined in the configuration register as follows:

Configuration register

MSB																LSB	
F	E	D	C	B	A	9	8	7	6	5	4	3	2	1	0		
-	-	-	-	-	-	HC	DA6	DA5	DA4	DA3	DA2	DA1	DA0	-	-		

1. Bit 9 is HC bit. The setting is in the low current range when HC=0, and in the high current range when HC=1.
2. Bit 8 to bit 2 are DA6 ~ DA0.

The relationship between these bits and current gain G is:

$$HC = 1, D = (256G-128)/3$$

$$HC = 0, D = (1024G-128)/3$$

and D in the above decimal numeration can be converted to its equivalent in binary form by the following equation:

$$D = DA6x2^6 + DA5x2^5 + DA4x2^4 + DA3x2^3 + DA2x2^2 + DA1x2^1 + DA0x2^0$$

In other words, these bits can be looked as a floating number with 1-bit exponent HC and 7-bit mantissa DA6~DA0.

For example,

$$HC = 1, G = 1.25, D = (256 \times 1.25 - 128) / 3 = 64$$

the D in binary form would be:

$$D = 64 = 1 \times 2^6 + 0 \times 2^5 + 0 \times 2^4 + 0 \times 2^3 + 0 \times 2^2 + 0 \times 2^1 + 0 \times 2^0$$

The bit 9 to bit 2 of the configuration register are set to 8'b1100,0000.

14 Delay time of staggered output

This feature prevents large inrush current from the power line and reduces the bypass capacitors.

The outputs are organized in four groups OUT4n, OUT4n+1, OUTn4+2, OUT4n+3 and each group has 40 ns delay between the previous one.

E.g.: OUT4n has no delay, OUTn4+1 has 40ns delay, OUTn4+2 has 80ns delay, OUTn4+3 has 120 ns delay.

15 Thermal protection

Thermal flag provides an indication about the status of the junction temperature. When the junction temperature reaches 150 °C the bit E of the configuration register is set to "1", signaling dangerous operating condition. This flag is useful when thermal shutdown function is disabled.

The thermal shutdown function, if activated by configuration register (bit "1" set to 1), turns-off all output channels if the junction exceeds 150 °C. As soon as the junction temperature is below 140 °C the outputs channels will be turned ON. In thermal shutdown mode, the digital core is active and data flow is guaranteed.

16 Time-out alert of GCLK disconnection

When the PWCLK signal is disconnected for around 1 second, all output ports will be turned off automatically. This function will protect the LED display system from staying ON indefinitely and prevent excessive current from damaging the power system. The default is set to 'enable' when bit "0" of the Configuration Register is 0. When the PWCLK is active again and new serial data are moved in, the driver resumes to work after resetting the internal counters and comparators.

Figure 17. Time-out alert application scheme

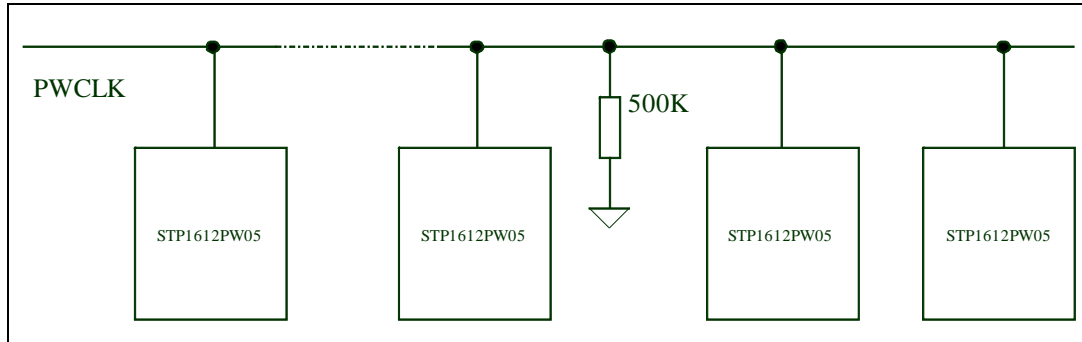

17 Application information

17.1 LED supply voltage (VLED)

The choice of the LED supply voltage (VLED) must be carried out considering several parameters:

- The voltage drop across current generators (V_{O_i}), which must be enough to guarantee the desired current (see [Figure 14](#) and [Figure 15](#))
- The maximum LED forward voltage ($V_{F,max}$)
- The maximum power that can be dissipated by the package under the application ambient conditions
- The accuracy of the supply voltage itself (VLED can vary in a range and the minimum value should be considered)

Therefore the minimum LED supply voltage can be calculated as:

$$V_{LED,min} = V_{O,typ} + V_{F,max}$$

The LED supply voltage should be higher than $V_{LED,min}$ (to consider any fluctuation of the involved parameters) but not too high in order to keep low the power dissipation:

$$P_D = V_{DD} \cdot I_{DD} + \sum_{i=1}^{16} V_{O,i} \cdot I_{CHi} \cdot D_i$$

where D_i is the duty cycle of the channel i .

In particular the power dissipation should be kept below the maximum power dissipation, defined as:

$$P_{D,max} = \frac{(T_j - T_a)}{\theta_{ja}}$$

To summarize, the choice of the proper power supply must be a trade-off between the correct value that assures the desired LED current and low power dissipation.

In RGB application, there can be a significant variability of the LEDs forward voltage (e.g. red LEDs have a lower forward voltage compared to green and blue ones).

In this case the supply voltage must be chosen high enough to correctly switch on the LEDs with the highest forward voltage (green or blue). However this supply voltage is higher than the voltage required by red LEDs. Thus, the excess of voltage in the lines with red LEDs drops on the current generators, bringing to an increase of the power dissipation and loss of efficiency.

Moreover the extra-voltage across the red LEDs driving generators could cause an erroneous shorted LED condition detection.

To avoid these drawbacks, two different approaches are possible:

- **Figure 18** shows an application with only one voltage rail (VLED). A resistor in series to each red LEDs is added. In this way, the voltage excess drops across the resistor instead of dropping across the current generators. This solution implies a significant reduction of the power dissipated by the chip. However the total power dissipation does not change and a remarkable part of the power is still wasted on the series resistor.

This not only affects the efficiency, but also raises the cost of the system due to the need to dissipate the generated heat.

Figure 18. Solution with single supply voltage

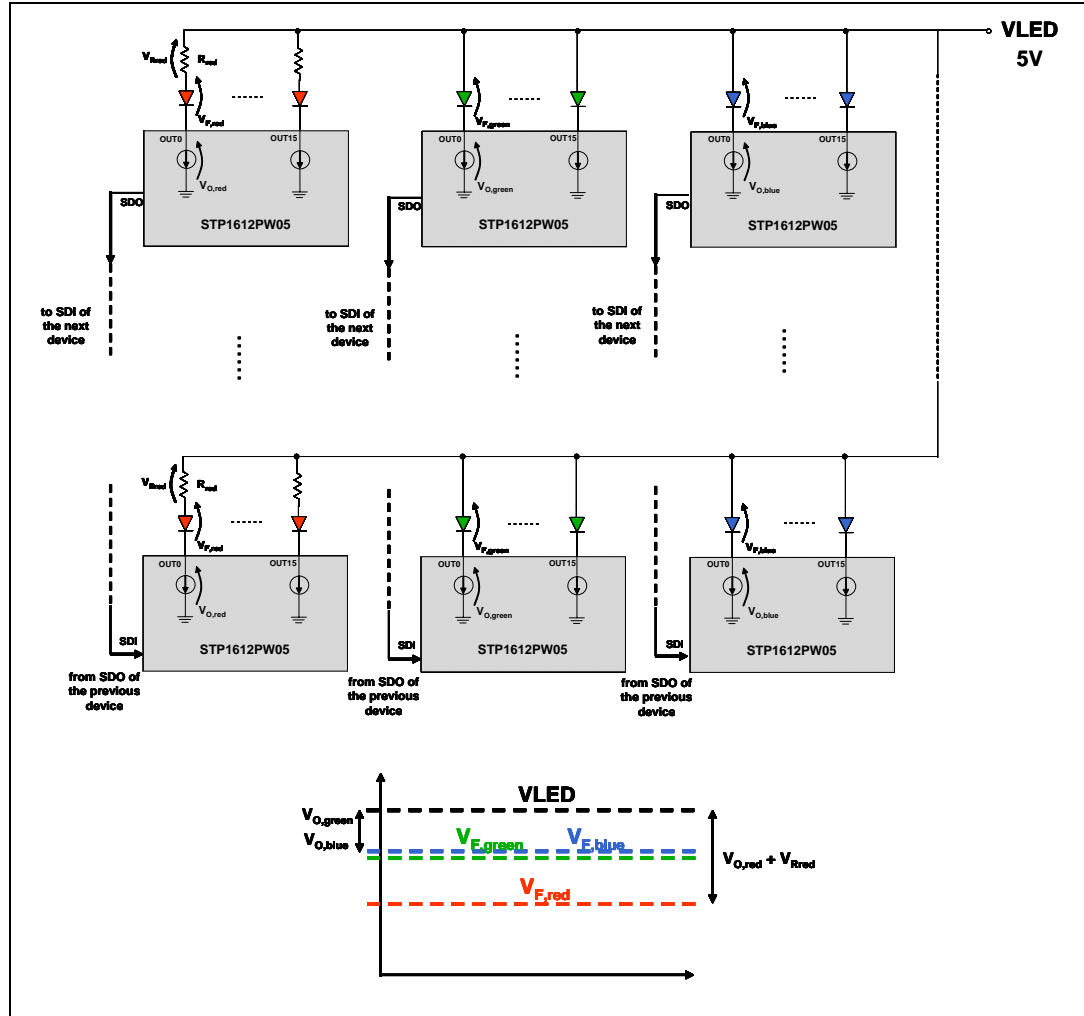

- **Figure 19** shows a solution with two separate voltage rails: one for blue and green LEDs (VLED) and one for red LEDs (VLED_RED), which can be derived from the former (e.g. simply using a voltage regulator). This solution is by far the most advantageous in terms of power dissipation. Voltage rails are tailored to the type of LEDs they drive and the wasted power is significantly reduced as well as the heat produced.

Figure 19. Solution with separated supply voltage for red LEDs

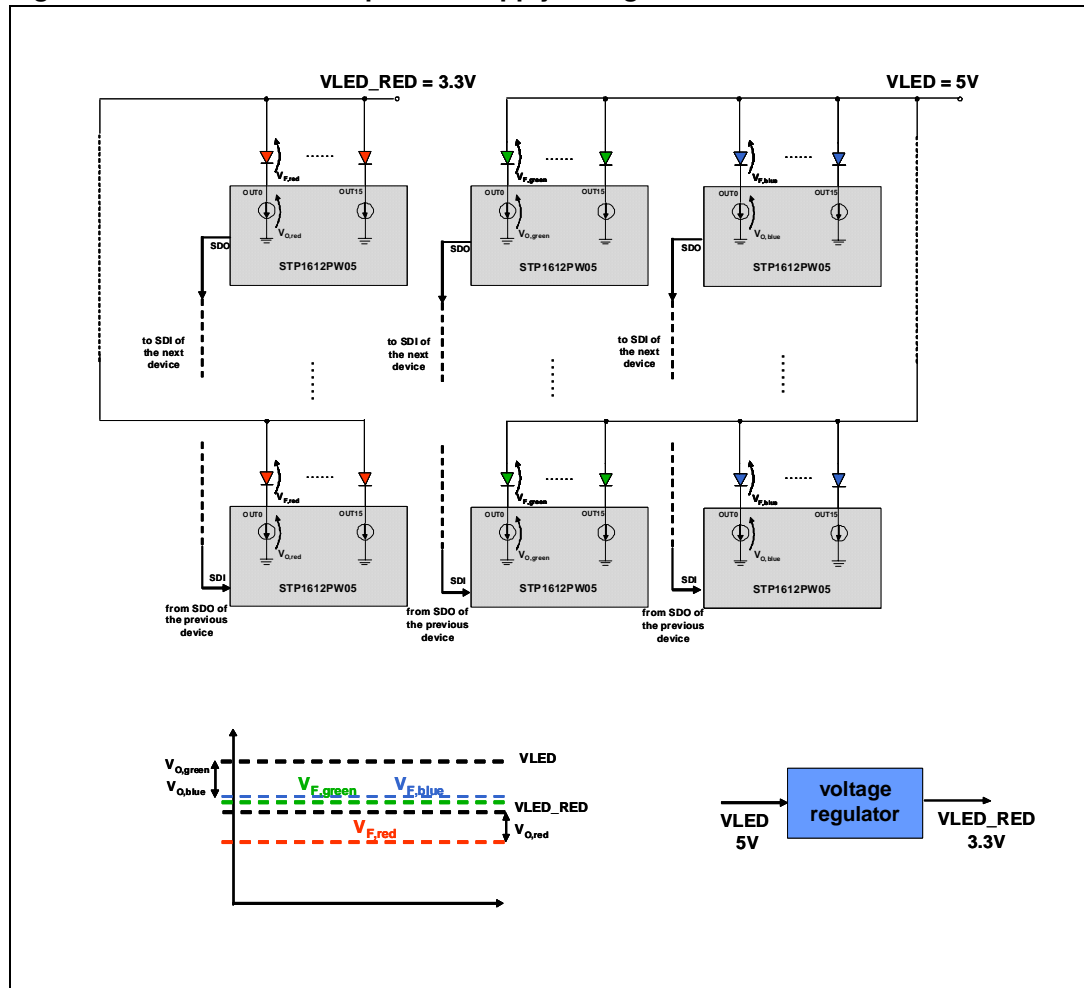

17.2 Setting grayscale brightness

As explained in section 8, the brightness of each channel can be adjusted using 12 or 16 bit per channel PWM control scheme, resulting in respectively 4095 or 65535 steps, from 0% to 100% brightness.

The brightness level of each output can be calculated as:

$$\text{Brightness\%} = \frac{GS_{\text{value},n}}{GS_{\text{max}}} \cdot 100$$

Where $GS_{\text{value},n}$ is the programmed grayscale value for OUTn (n from 0 to 15), which can be up to 4095 or 65535, whereas GS_{max} is the maximum grayscale value programmable: 4095 (12bit) or 65535 (16bit).

So, once the brightness level for the channel n is defined, according to the bit “D” of the configuration register (see section 8), the $GS_{\text{value},n}$ can be calculated. Then, converting this value into a binary word, the correct string to load into the register is achieved (see [Figure 20](#)).

Figure 20. Example of brightness setting

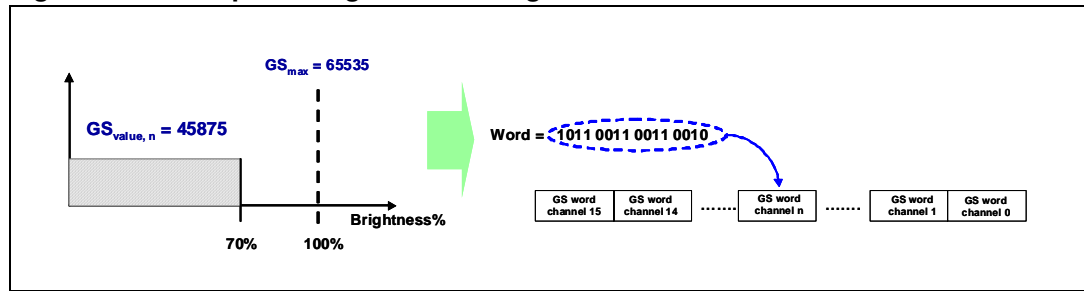

17.3 Multi device application

In a typical application several devices are used to drive the LEDs.

In this case more STP1612PW05 can be connected together in a daisy chain configuration as shown in [Figure 21](#).

Figure 21. STP1612PW05 in daisy chain configuration

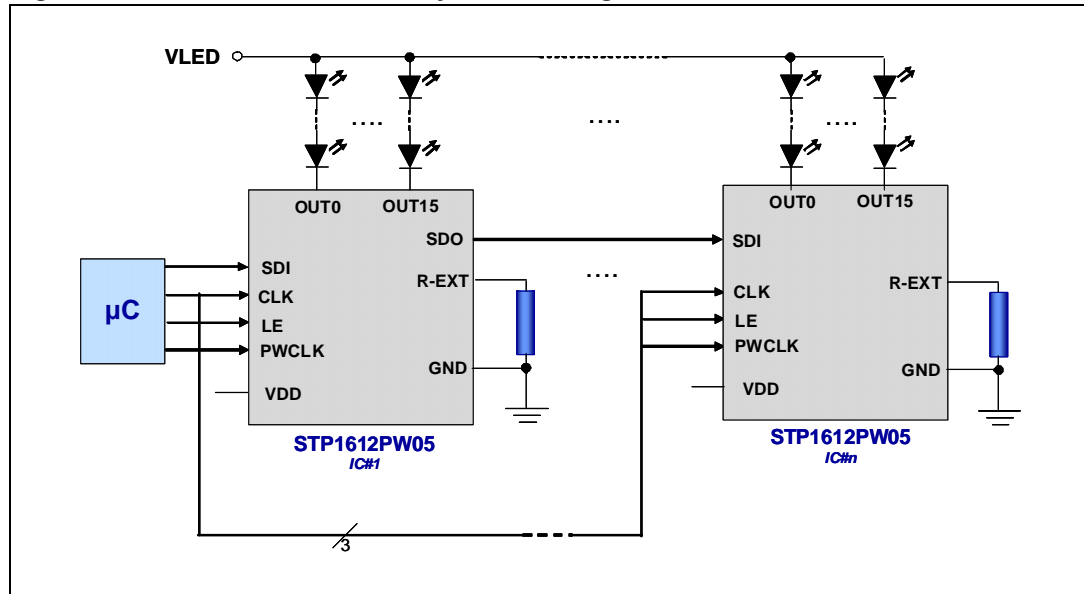

18 Package mechanical data

In order to meet environmental requirements, ST offers these devices in different grades of ECOPACK® packages, depending on their level of environmental compliance. ECOPACK® specifications, grade definitions and product status are available at: www.st.com. ECOPACK is an ST trademark.

Table 15. TSSOP24 mechanical data

Dim.	mm.			inch		
	Min.	Typ	Max.	Min.	Typ.	Max.
A			1.1			0.043
A1	0.05		0.15	0.002		0.006
A2		0.9			0.035	
b	0.19		0.30	0.0075		0.0118
c	0.09		0.20	0.0035		0.0079
D	7.7		7.9	0.303		0.311
E	4.3		4.5	0.169		0.177
e		0.65 BSC			0.0256 BSC	
H	6.25		6.5	0.246		0.256
K	0°		8°	0°		8°
L	0.50		0.70	0.020		0.028

Figure 22. TSSOP24 package dimensions

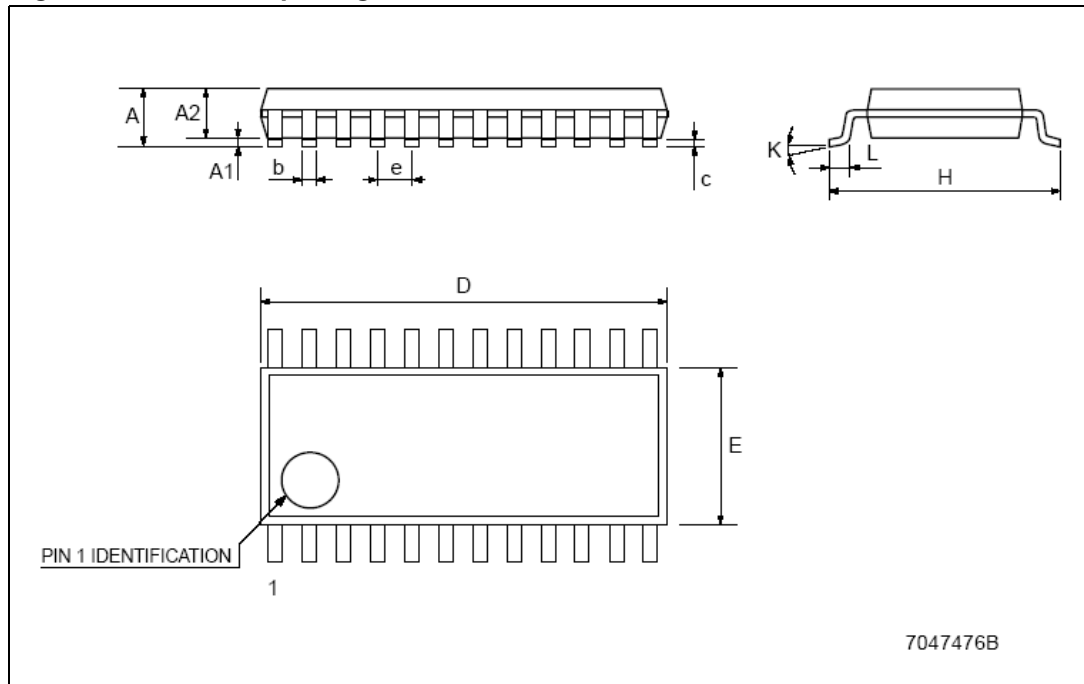

Table 16. TSSOP24 tape and reel

Dim.	mm.			inch		
	Min.	Typ	Max.	Min.	Typ.	Max.
A		-	330		-	12.992
C	12.8	-	13.2	0.504	-	0.519
D	20.2	-		0.795	-	
N	60	-		2.362	-	
T		-	22.4		-	0.882
Ao	6.8	-	7	0.268	-	0.276
Bo	8.2	-	8.4	0.323	-	0.331
Ko	1.7	-	1.9	0.067	-	0.075
Po	3.9	-	4.1	0.153	-	0.161
P	11.9	-	12.1	0.468	-	0.476

Figure 23. TSSOP24 reel dimensions

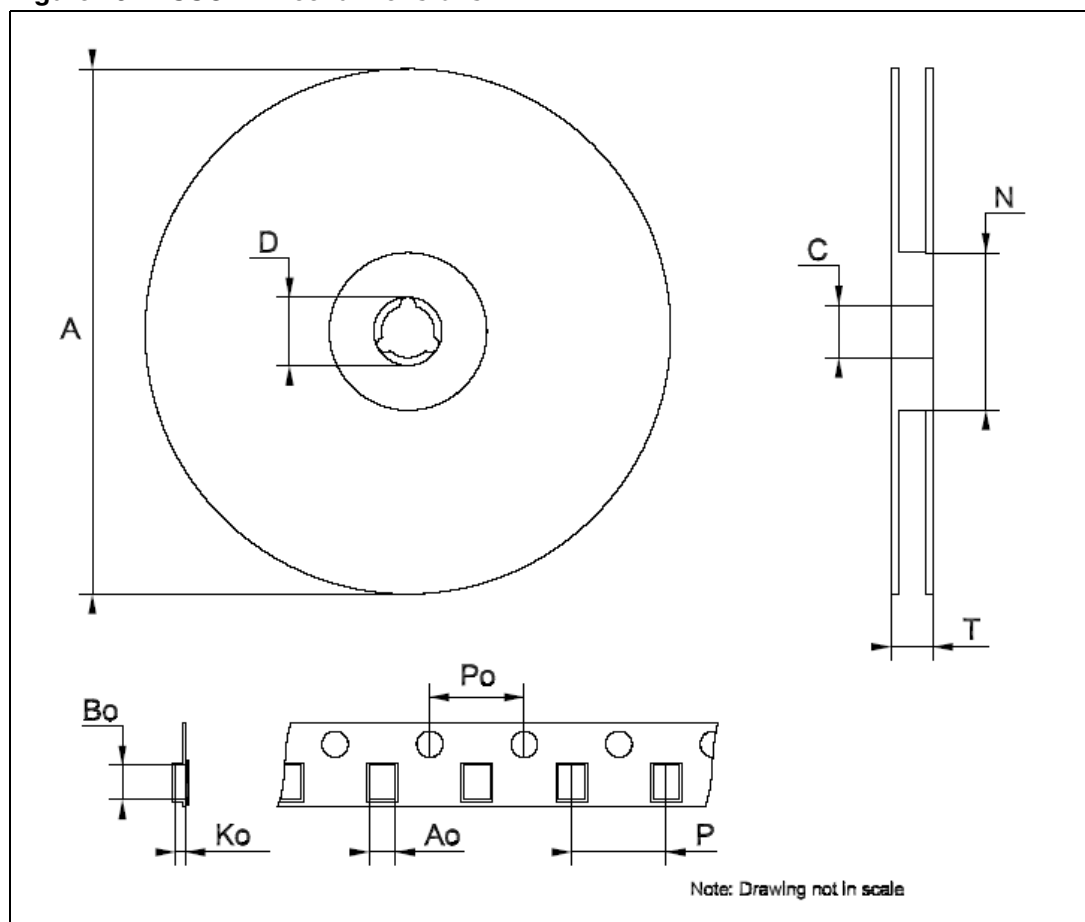

Table 17. SO-24 mechanical data

Dim.	mm.			inch		
	Min.	Typ	Max.	Min.	Typ.	Max.
A	2.35		2.65	2.36		2.5
A1	0.1		0.3	0.12	0.15	0.18
B	0.33		0.51	0.375	0.4	0.425
C	0.23		0.32			0.292
D ⁽¹⁾	15.2		15.6	15.43	15.46	15.49
E	7.4		7.6	7.52	7.55	7.58
e		1.27			1.27	
H	10		10.65	10.2	10.3	10.4
h	0.25		0.75		0.35	
L	0.4		1.27	0.6		0.75
k	0		8	2	4	6
ddd			0.1			0.06

1. Dimension "D" does not include mold flash, protrusions or gate burrs. Mold flash, protrusions or gate burrs shall not exceed 0.15mm per side.

Figure 24. SO-24 package dimensions

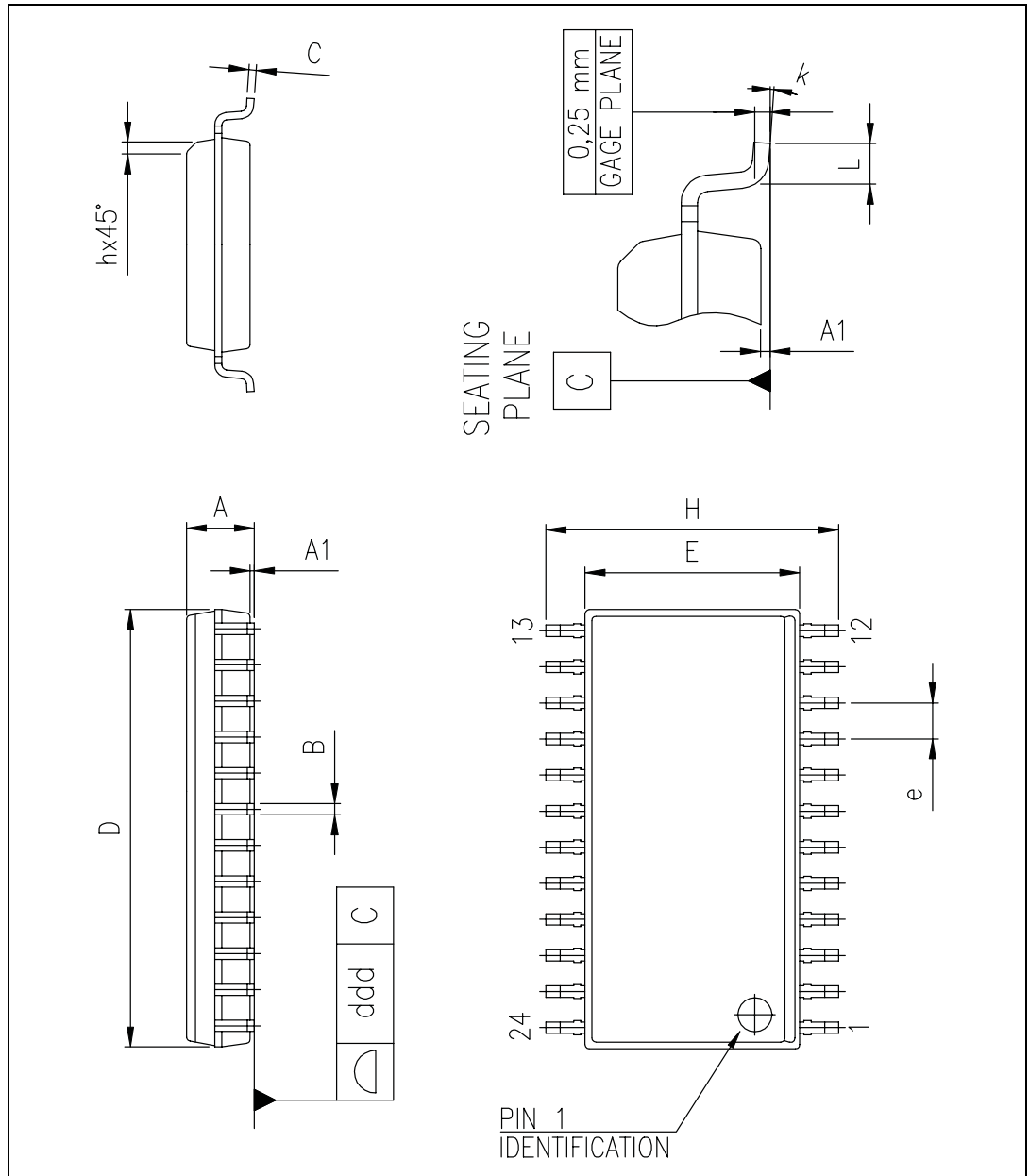

Table 18. SO-24 tape and reel

Dim.	mm.			inch		
	Min.	Typ	Max.	Min.	Typ.	Max.
A		-	330		-	12.992
C	12.8	-	13.2	0.504	-	0.519
D	20.2	-		0.795	-	
N	60	-		2.362	-	
T		-	30.4		-	1.197
Ao	10.8	-	11.0	0.425	-	0.433
Bo	15.7	-	15.9	0.618	-	0.626
Ko	2.9	-	3.1	0.114	-	0.122
Po	3.9	-	4.1	0.153	-	0.161
P	11.9	-	12.1	0.468	-	0.476

Figure 25. SO-24 reel dimensions

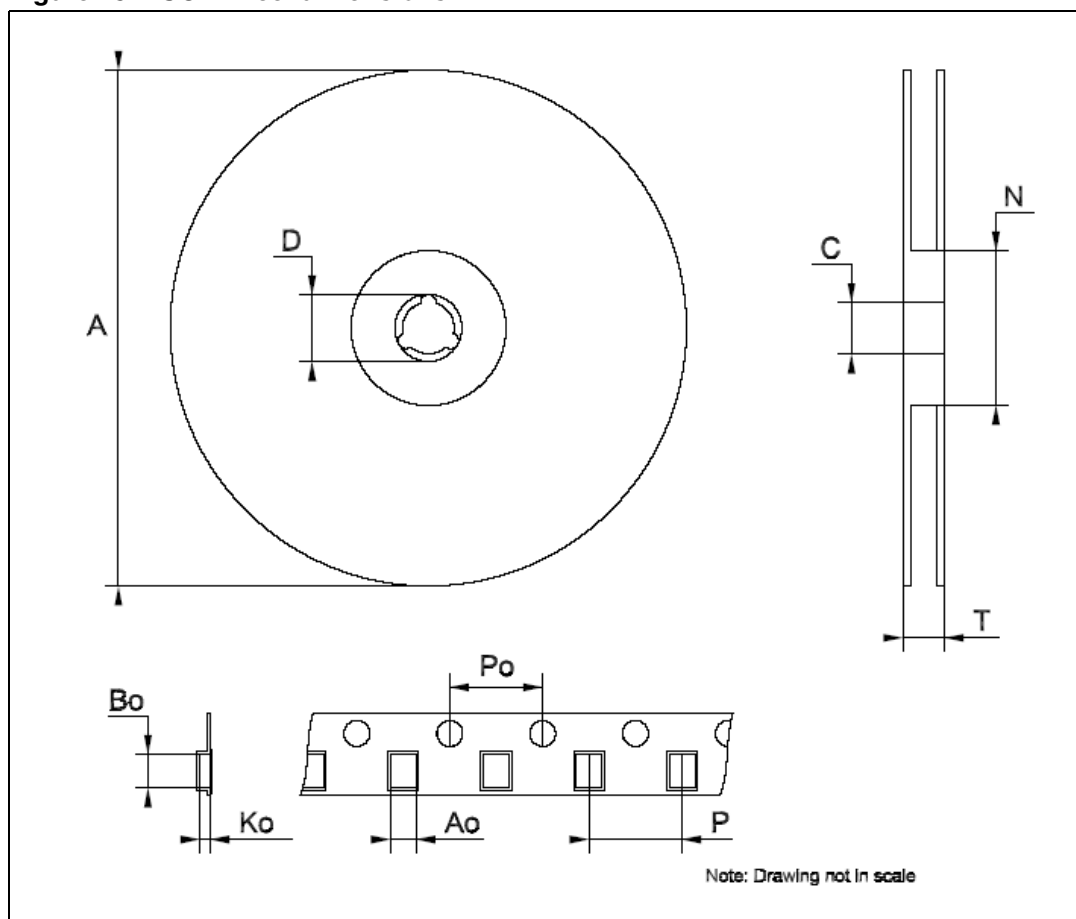

Table 19. TSSOP24 exposed pad

Dim.	mm			inch		
	Min.	Typ.	Max.	Min.	Typ.	Max.
A			1.2			0.047
A1			0.15	0.004		0.006
A2	0.8	1	1.05	0.031	0.039	0.041
b	0.19		0.30	0.007		0.012
c	0.09		0.20	0.004		0.0089
D	7.7	7.8	7.9	0.303	0.307	0.311
D1	4.7	5.0	5.3	0.185	0.197	0.209
E	6.2	6.4	6.6	0.244	0.252	0.260
E1	4.3	4.4	4.5	0.169	0.173	0.177
E2	2.9	3.2	3.5	0.114	0.126	0.138
e		0.65			0.0256	
K	0°		8°	0°		8°
L	0.45	0.60	0.75	0.018	0.024	0.030

Figure 26. TSSOP24 package dimensions

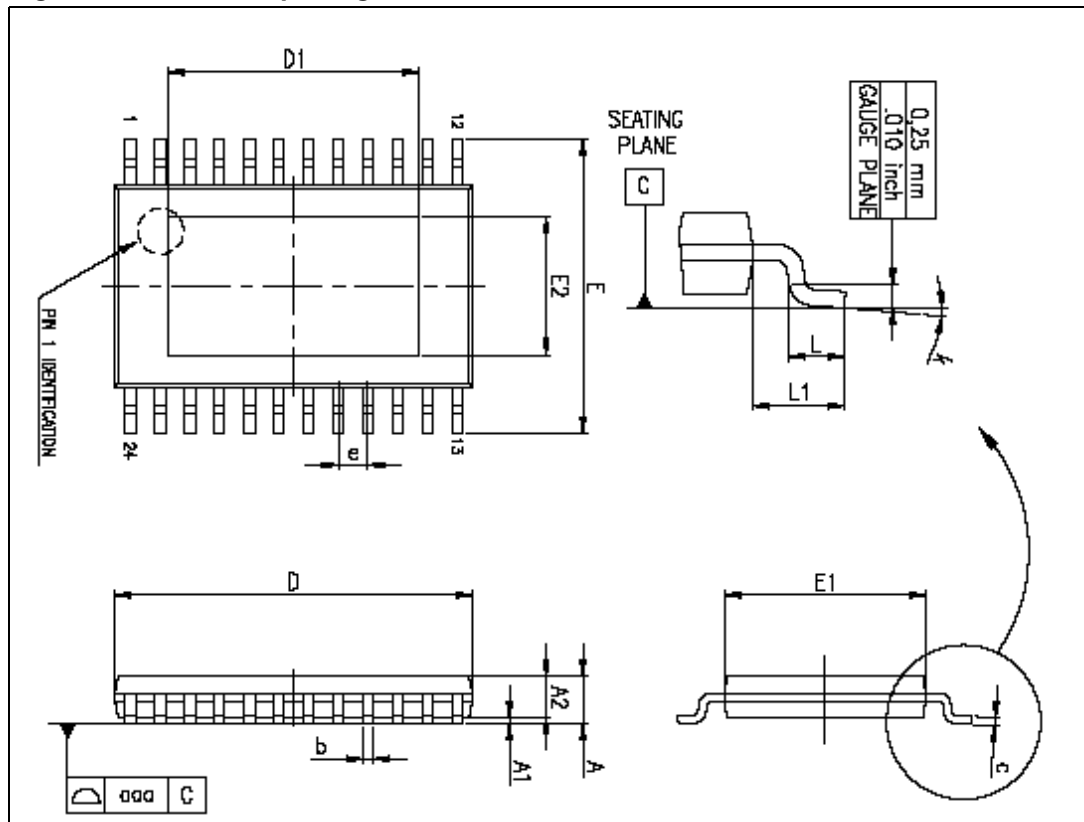
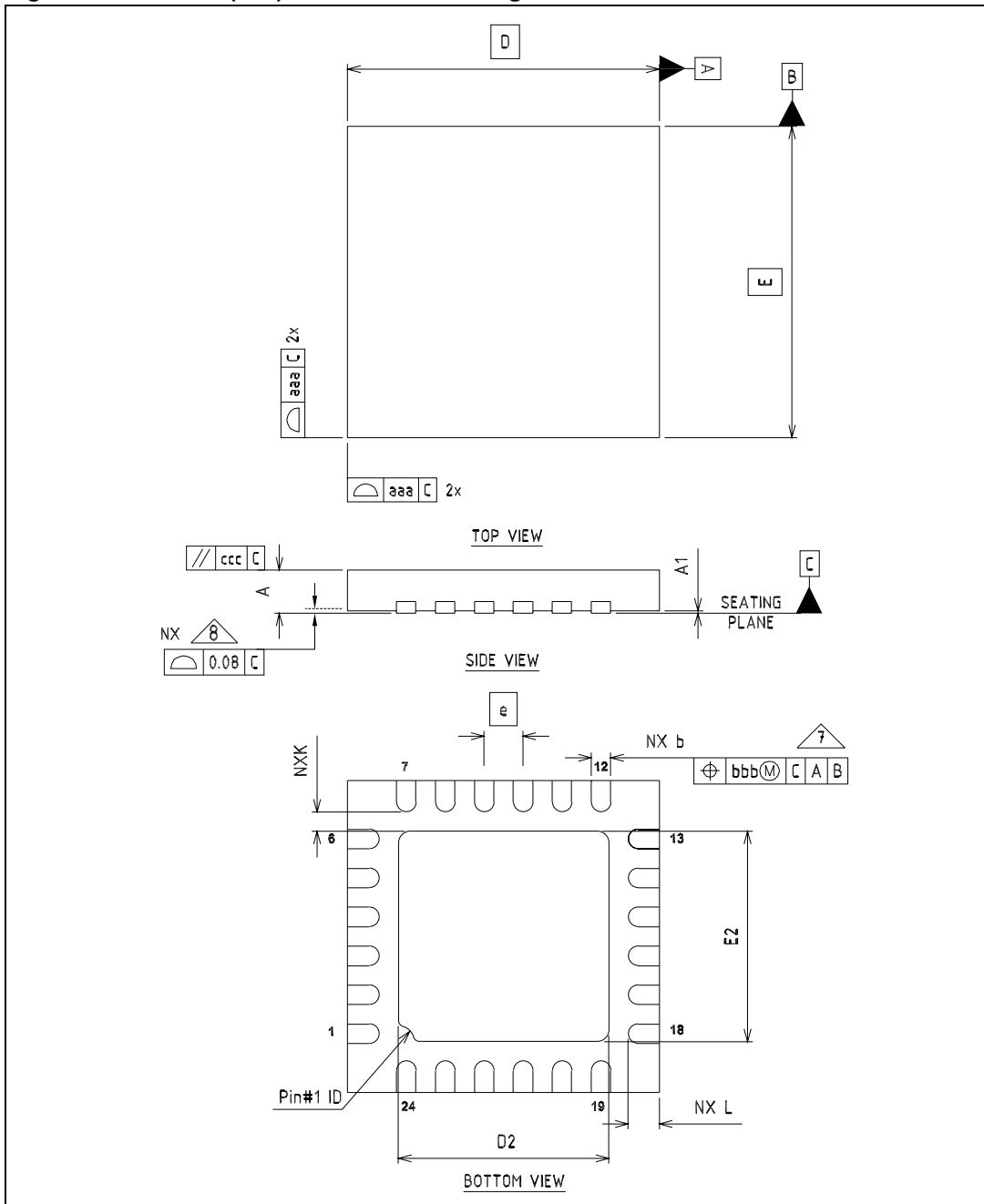

Table 20. QFN24 (4x4) mechanical data

Dim.	mm.			mils		
	Min.	Typ	Max.	Min.	Typ.	Max.
A			1.00			39.4
A1	0.00		0.05	0.0		2.0
b	0.18		0.30	7.1		11.8
D	3.9		4.1	153.5		161.4
D2	2.6		2.8	76.8		88.6
E	3.9		4.1	153.5		161.4
E2	2.6		2.8	76.8		88.6
e		0.50			19.7	
L	0.40		0.60	15.7		23.6

Figure 27. QFN24 (4x4) mechanical drawing



Tape & Reel QFNxx/DFNxx (4x4) MECHANICAL DATA

DIM.	mm.			inch		
	MIN.	TYP.	MAX.	MIN.	TYP.	MAX.
A			330			12.992
C	12.8		13.2	0.504		0.519
D	20.2			0.795		
N	99		101	3.898		3.976
T			14.4			0.567
Ao		4.35			0.171	
Bo		4.35			0.171	
Ko		1.1			0.043	
Po		4			0.157	
P		8			0.315	

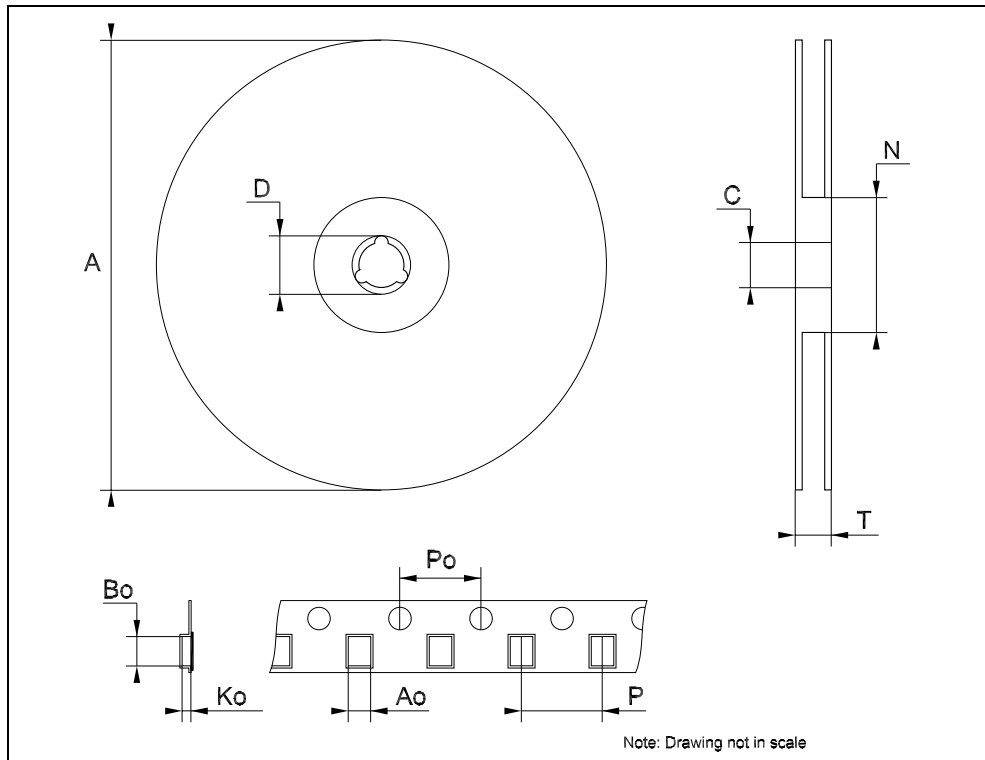

19 Revision history

Table 21. Document revision history

Date	Revision	Changes
17-Jun-2009	1	Initial release.
10-Aug-2009	2	Updated Section 9.2 on page 19 and Table 11 on page 14
29-Oct-2009	3	Updated: Figure 2 on page 6 and Table 20 on page 37 Added: Figure 17 on page 26
18-Dec-2009	4	Updated Section 11 on page 22
08-Feb-2011	5	Updated Table 17 on page 33 and Figure 24 on page 34

Please Read Carefully:

Information in this document is provided solely in connection with ST products. STMicroelectronics NV and its subsidiaries ("ST") reserve the right to make changes, corrections, modifications or improvements, to this document, and the products and services described herein at any time, without notice.

All ST products are sold pursuant to ST's terms and conditions of sale.

Purchasers are solely responsible for the choice, selection and use of the ST products and services described herein, and ST assumes no liability whatsoever relating to the choice, selection or use of the ST products and services described herein.

No license, express or implied, by estoppel or otherwise, to any intellectual property rights is granted under this document. If any part of this document refers to any third party products or services it shall not be deemed a license grant by ST for the use of such third party products or services, or any intellectual property contained therein or considered as a warranty covering the use in any manner whatsoever of such third party products or services or any intellectual property contained therein.

UNLESS OTHERWISE SET FORTH IN ST'S TERMS AND CONDITIONS OF SALE ST DISCLAIMS ANY EXPRESS OR IMPLIED WARRANTY WITH RESPECT TO THE USE AND/OR SALE OF ST PRODUCTS INCLUDING WITHOUT LIMITATION IMPLIED WARRANTIES OF MERCHANTABILITY, FITNESS FOR A PARTICULAR PURPOSE (AND THEIR EQUIVALENTS UNDER THE LAWS OF ANY JURISDICTION), OR INFRINGEMENT OF ANY PATENT, COPYRIGHT OR OTHER INTELLECTUAL PROPERTY RIGHT.

UNLESS EXPRESSLY APPROVED IN WRITING BY AN AUTHORIZED ST REPRESENTATIVE, ST PRODUCTS ARE NOT RECOMMENDED, AUTHORIZED OR WARRANTED FOR USE IN MILITARY, AIR CRAFT, SPACE, LIFE SAVING, OR LIFE SUSTAINING APPLICATIONS, NOR IN PRODUCTS OR SYSTEMS WHERE FAILURE OR MALFUNCTION MAY RESULT IN PERSONAL INJURY, DEATH, OR SEVERE PROPERTY OR ENVIRONMENTAL DAMAGE. ST PRODUCTS WHICH ARE NOT SPECIFIED AS "AUTOMOTIVE GRADE" MAY ONLY BE USED IN AUTOMOTIVE APPLICATIONS AT USER'S OWN RISK.

Resale of ST products with provisions different from the statements and/or technical features set forth in this document shall immediately void any warranty granted by ST for the ST product or service described herein and shall not create or extend in any manner whatsoever, any liability of ST.

ST and the ST logo are trademarks or registered trademarks of ST in various countries.

Information in this document supersedes and replaces all information previously supplied.

The ST logo is a registered trademark of STMicroelectronics. All other names are the property of their respective owners.

© 2011 STMicroelectronics - All rights reserved

STMicroelectronics group of companies

Australia - Belgium - Brazil - Canada - China - Czech Republic - Finland - France - Germany - Hong Kong - India - Israel - Italy - Japan - Malaysia - Malta - Morocco - Philippines - Singapore - Spain - Sweden - Switzerland - United Kingdom - United States of America

www.st.com



Looking for pricing, stock, or lifecycle information?

Click below to explore more details on WIN SOURCE:

- ⊖ [View STP1612PW05TTR on WIN SOURCE](#)
- ⊖ [STMicroelectronics Information](#)

Optimize Your Supply Chain with WIN SOURCE Solutions

- ✓ Global Sourcing Solution
- ✓ Obsolete Management
- ✓ Cost Control Management
- ✓ Shortage Management
- ✓ Alternative Solution
- ✓ Excess Inventory Management