



**THE DATASHEET OF  
A5932GESSR-T**



## Three-Phase Sinusoidal Sensorless Fan Controller

### FEATURES AND BENEFITS

- Automotive grade, AEC-Q100 qualified
- Sinusoidal drive for low vibration and noise
- Configurable closed loop speed curves
- RD output
- Quiet startup
- Proprietary high-efficiency control algorithm
- Automatic phase advance
- Windmill detection
- Fault output
- FG speed output
- Lock detection
- Overcurrent limit (OCL)
- Short-circuit protection (OCP)
- Direction input
- Brake input
- Adjustable gate drive

### DESCRIPTION

The A5932 three-phase motor controller incorporates sinusoidal drive to minimize audible noise and vibration for high-power fans.

A sinusoidal voltage profile is applied to the windings of the motor at startup to quietly start up and gradually ramp up the motor to desired speed.

The motor speed is controlled by applying a duty cycle command to the speed (SPD) input. The SPD input is allowed to operate over a wide frequency range.

The A5932 is available in a 24-contact 4 mm × 4 mm QFN with exposed thermal pad (suffix ES), a 24-contact 4 mm × 4 mm QFN with exposed thermal pad and wettable flank (suffix ES, -J option), and a 24-lead TSSOP with exposed thermal pad (suffix LP). These packages are lead (Pb) free, with 100% matte-tin leadframe plating.

### PACKAGES: *Not to scale*

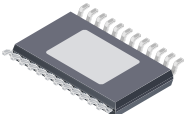
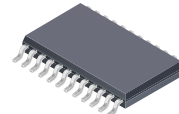
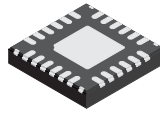
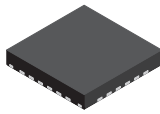
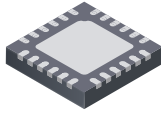
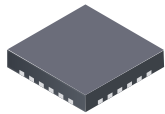

24-contact QFN  
with exposed thermal pad  
4 mm × 4 mm × 0.75 mm  
(ES package)

24-contact QFN wettable flank  
with exposed thermal pad  
4 mm × 4 mm × 0.75 mm  
(ES package, -J option)

24-lead TSSOP  
with exposed thermal pad  
(LP package)

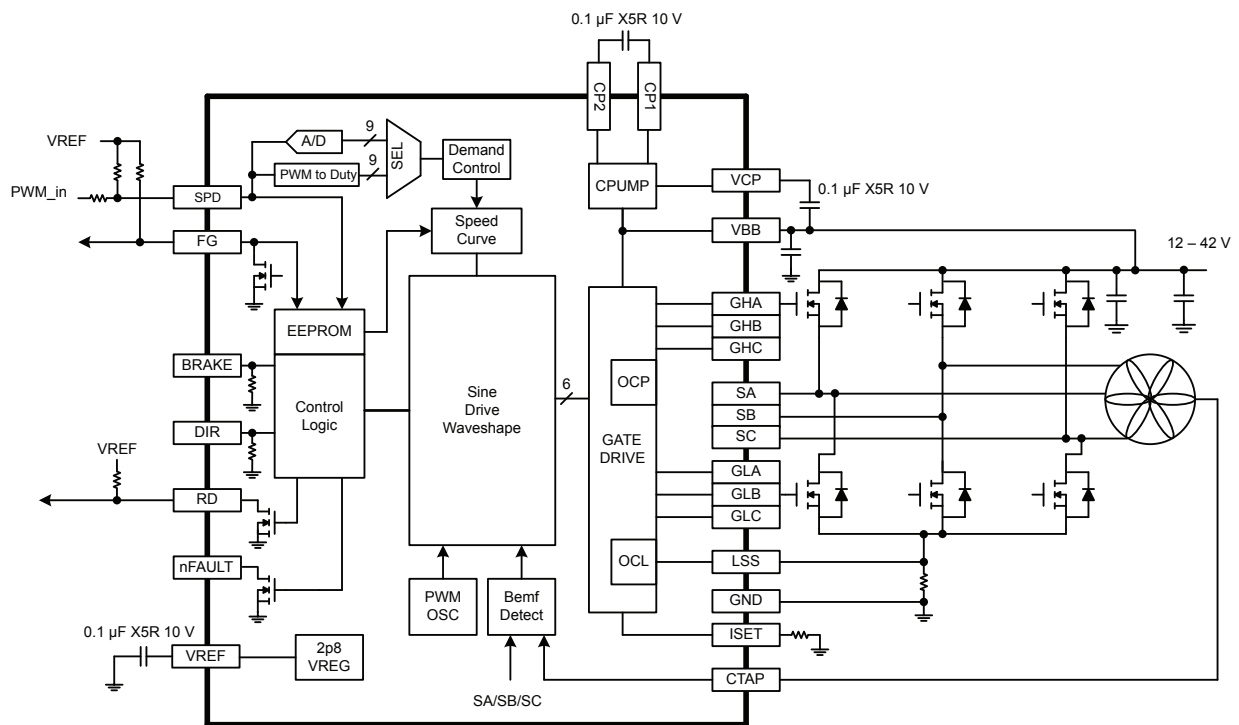

Figure 1: Typical Application

## SELECTION GUIDE

Part Number	Operating Temperature Range (T <sub>A</sub> ) (°C)	Packaging	Packing
A5932GESSR-T	-40 to 105	24-contact QFN with exposed thermal pad	6000 pieces per 13-inch reel
A5932KESSR-J	-40 to 150	24-contact QFN wettable flank with exposed thermal pad	contact factory
A5932GLPTR-T	-40 to 105	24-lead TSSOP with exposed thermal pad	4000 pieces per 13-inch reel
A5932KLPTR-T	-40 to 150	24-lead TSSOP with exposed thermal pad	4000 pieces per 13-inch reel



## ABSOLUTE MAXIMUM RATINGS

Characteristic	Symbol	Notes	Rating	Unit
Supply Voltage	V <sub>BB</sub>		50	V
Logic Input Voltage Range	V <sub>IN</sub>	SPD, BRAKE, DIR	-0.3 to 6	V
Logic Output	V <sub>O</sub>	FG (I < 5 mA), RD, nFAULT	6	V
LSS	V <sub>LSS</sub>	DC	±500	mV
		t <sub>w</sub> < 500 ns	±4	V
Output Voltage	V <sub>OUT</sub>	SA, SB, SC	-2 to V <sub>BB</sub> +2	V
CTAP	V <sub>CTAP</sub>	DC	-0.6 to V <sub>BB</sub> +0.6	V
		t <sub>w</sub> < 500 ns	-2 to V <sub>BB</sub> +2	V
GHx	V <sub>GHx</sub>		V <sub>SX</sub> -0.3 to V <sub>CP</sub> +0.3	V
GLx	V <sub>GLx</sub>		V <sub>LSS</sub> -0.3 to 8.5	V
VCP	V <sub>CP</sub>		V <sub>BB</sub> -0.3 to V <sub>BB</sub> +8	V
CP1	V <sub>CP1</sub>		-0.3 to V <sub>BB</sub> +0.3	V
CP2	V <sub>CP2</sub>		V <sub>BB</sub> -0.3 to V <sub>CP</sub> +0.3	V
ISET	V <sub>ISET</sub>		-0.3 to 5.5	V
Maximum EEPROM Write Cycles	EEPROM <sub>W(MAX)</sub>		1000	cycles
Junction Temperature	T <sub>J</sub>		150	°C
Storage Temperature Range	T <sub>stg</sub>		-55 to 150	°C
Operating Temperature Range	T <sub>A</sub>	Range G	-40 to 105	°C
		Range K	-40 to 150	°C

## THERMAL CHARACTERISTICS

Characteristic	Symbol	Test Conditions*	Value	Unit
Package Thermal Resistance	R <sub>θJA</sub>	24-contact QFN (package ES), on 2-sided PCB 1-in. <sup>2</sup> copper	45	°C/W
		24-lead TSSOP (package LP), on 2-sided PCB 1-in. <sup>2</sup> copper	36	°C/W

\*Additional thermal information available on the Allegro website.

**Table of Contents**

Features and Benefits.....	1	Basic Operation .....	7
Description .....	1	Speed Curve Parameters.....	9
Packages .....	1	EEPROM Map.....	14
Typical Application.....	1	Serial Port Control Option .....	17
Specifications .....	2	Serial Port .....	18
Selection Guide .....	2	I <sup>2</sup> C Timing Diagrams .....	18
Absolute Maximum Ratings.....	2	Write Command.....	19
Thermal Characteristics .....	2	Read Command .....	19
Pinout Diagram and Terminal List Table .....	4	Programming EEPROM.....	20
Electrical Characteristics .....	5	Pin Diagrams.....	22
Functional Description .....	7	Package Outline Drawings .....	23

## PINOUT DIAGRAMS AND TERMINAL LIST TABLE

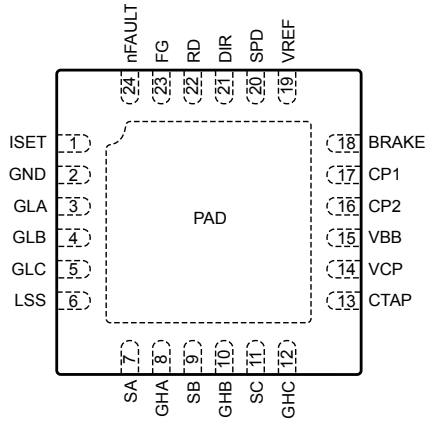

**ES Package Pinouts**

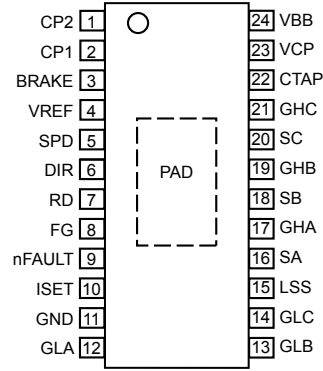

**LP Package Pinouts**

**Terminal List Table**

Terminal Number		Name	Function
ES Package	LP Package		
16	1	CP2	Charge pump
17	2	CP1	Charge pump
18	3	BRAKE	Logic input
19	4	VREF	Logic supply output
20	5	SPD	Speed input
21	6	DIR	Logic output
22	7	RD	Speed output
23	8	FG	Speed output
24	9	nFAULT	Logic output
1	10	ISET	Analog input
2	11	GND	Ground
3	12	GLA	Gate drive output
4	13	GLB	Gate drive output
5	14	GLC	Gate drive output
6	15	LSS	Low side source
7	16	SA	Motor output
8	17	GHA	Gate drive output
9	18	SB	Motor output
10	19	GHB	Gate drive output
11	20	SC	Motor output
12	21	GHC	Gate drive output
13	22	CTAP	Motor common
14	23	VCP	Charge pump
15	24	VBB	Power supply
PAD	PAD	PAD	Exposed pad for enhanced thermal dissipation

**ELECTRICAL CHARACTERISTICS [1]:** Valid for  $T_A = -40^\circ\text{C}$  to  $105^\circ\text{C}$  (G version) or  $-40^\circ\text{C}$  to  $150^\circ\text{C}$  (K version), unless noted otherwise

Characteristics	Symbol	Test Conditions	Min.	Typ.	Max.	Unit
<b>GENERAL</b>						
Load Supply Voltage Range	$V_{BB}$	Driving	–	–	$V_{BBOV}$	V
		Operating	5.5	–	50	V
VBB Supply Current	$I_{BB}$	$I_{VREF} = 0\text{ mA}$	–	11	15	mA
		Standby mode	–	10	20	$\mu\text{A}$
Reference Voltage	$V_{REF}$	$I_{OUT} = 20\text{ mA}$	2.7	2.86	2.95	V
VREF Current Limit	$I_{REFOCL}$	$V_{REF} = 0\text{ V}$	25	50	80	mA
Charge Pump	$V_{CP}$	$V_{BB} = 8\text{ V}$ , relative to VBB	6.5	6.8	7.5	V
		$V_{BB} = 5.5\text{ V}$ , $I = 2\text{ mA}$	4.5	4.8	–	V
<b>GATE DRIVE [2]</b>						
High Side Gate Drive Output	$V_{GH}$	$V_{BB} = 8\text{ V}$	6.5	6.8	–	V
Low Side Gate Drive Output	$V_{GL}$	$V_{BB} = 8\text{ V}$	7	7.5	–	V
Gate Drive Source Current	$I_{SO}$	$V_{BB} = 8\text{ V}$ , relative to target, $R_{ISET} = 15\text{ to }60\text{ k}\Omega$	–25	–	25	%
		$V_{BB} = 8\text{ V}$ , $R_{ISET} = \text{GND}$	24	32.3	40	mA
Gate Drive Sink Current	$I_{SI}$	$V_{BB} = 8\text{ V}$ , relative to target, $R_{ISET} = 15\text{ to }30\text{ k}\Omega$	–25	–	25	%
		$V_{BB} = 8\text{ V}$ , relative to target, $R_{ISET} = 30\text{ to }60\text{ k}\Omega$	–36	–	36	%
		$V_{BB} = 8\text{ V}$ , $R_{ISET} = \text{GND}$	43	61.6	80	mA
<b>MOTOR DRIVE</b>						
PWM Duty On Threshold	$DC_{ON}$	Relative to target	–0.5	–	0.5	%
PWM Duty OFF Threshold	$DC_{OFF}$	Relative to target	–0.5	–	0.5	%
PWM Input Frequency Range	$f_{PWMIN}$		6 [3]	–	100	kHz
SPD Standby Threshold (Analog)	$V_{SPDTH}$		0.5	0.75	1	V
SPD On Threshold	$V_{SPDON}$	$DC_{ON} = 10\%$	195	235	280	mV
SPD Max	$V_{SPDMAX}$		–	2.485	–	V
SPD ADC Resolution	$V_{SPDADC}$		–	4.89	–	mV
SPD ADC Accuracy		$V_{SPD} = 0.2\text{ to }2.5\text{ V}$ , relative to equation	–8	–	8	LSB
Speed Setpoint	$f_{SPD}$	PWM mode	–4	–	4	%
Dead Time	$t_{DT}$	Code = 10	–	480	–	ns
Motor PWM Frequency	$f_{PWM}$		23.67	24.4	25.15	kHz

Continued on next page...

[1] Specified limits are tested at a single temperature and assured over temperature range by design and characterization.

[2] Gate drive output characteristics valid up to  $V_{BBOV}$ .

[3] Refer to description for SPD pin.

**ELECTRICAL CHARACTERISTICS [1] (continued):** Valid for  $T_A = -40^\circ\text{C}$  to  $105^\circ\text{C}$  (G version) or  $-40^\circ\text{C}$  to  $150^\circ\text{C}$  (K version), unless noted otherwise

Characteristics	Symbol	Test Conditions	Min.	Typ.	Max.	Unit
<b>PROTECTION</b>						
VBB UVLO	$V_{BBUVLO}$	$V_{BB}$ rising	–	4.75	4.95	V
VBB UVLO Hysteresis	$V_{BBHYS}$		200	300	450	mV
VBB Overvoltage Threshold	$V_{BBOV}$	Relative to target	–4	–	4	%
VBB Overvoltage Hysteresis	$V_{BBOVHYS}$		1.7	2	2.3	V
Overcurrent Threshold	$V_{OCL}$		240	255	270	mV
VREF UVLO	$V_{REFUVLO}$	Falling	2.52	2.6	2.68	V
VCP UVLO	$V_{CPUVLO}$	Falling	3.6	3.95	4.2	V
		Rising	4	4.25	4.5	V
Lock Timing	$t_{LOCK}$	Relative to target	–4	–	4	%
Thermal Shutdown Temperature	$T_{JTSD}$	Temperature increasing	155	170	190	$^\circ\text{C}$
Thermal Shutdown Hysteresis	$\Delta T_J$	Recovery = $T_{JTSD} - \Delta T_J$	–	20	–	$^\circ\text{C}$
<b>LOGIC / INPUT OUTPUT / I<sup>2</sup>C</b>						
Input Current (SPD, FG)	$I_{IN}$	$V_{IN} = 0$ to $5.5$ V	–5	<1	5	$\mu\text{A}$
Input Current (BRK, DIR)	$I_{IN}$	$V_{IN} = 5$ V	35	50	75	$\mu\text{A}$
Logic Input, Low Level	$V_{IL}$		0	–	0.8	V
Logic Input, High Level	$V_{IH}$		2	–	5.5	V
Logic Input Hysteresis	$V_{HYS}$		150	300	600	mV
Output Saturation Voltage	$V_{SAT}$	$I = 4$ mA	–	–	0.3	V
FG, RD, nFAULT Output Leakage	$I_{FG}$	$V = 6$ V	–	–	1	$\mu\text{A}$
SCL Clock Frequency	$f_{CLK}$		3	–	400	kHz
<b>I<sup>2</sup>C TIMING</b>						
Bus Free Time Between Stop/Start	$t_{BUF}$		1.3	–	–	$\mu\text{s}$
Hold Time Start Condition	$t_{HD:STA}$		0.6	–	–	$\mu\text{s}$
Setup Time for Start Condition	$t_{SU:STA}$		0.6	–	–	$\mu\text{s}$
SCL Low Time	$t_{LOW}$		1.3	–	–	$\mu\text{s}$
SCL High Time	$t_{HIGH}$		0.6	–	–	$\mu\text{s}$
Data Setup Time	$t_{SU:DAT}$		100	–	–	ns
Data Hold Time	$t_{HD:DAT}$		0	–	900	ns
Setup Time for Stop Condition	$t_{SU:STO}$		0.6	–	–	$\mu\text{s}$

[1] Specified limits are tested at a single temperature and assured over temperature range by design and characterization.

FUNCTIONAL DESCRIPTION

The A5932 targets high-speed server fan applications to meet the objectives of low audible noise, minimal vibration, and high efficiency. Allegro’s proprietary control algorithm results in a sinusoidal current waveshape that adapts to a variety of motor characteristics to dynamically optimize efficiency across a wide range of speeds.

The speed of the fan is controlled by variable duty cycle PWM input. The PWM input duty is measured and converted to a 9-bit number. This 9-bit “demand” is applied to a PWM generator block to create the modulation profile. The modulation profile

is applied to the three motor outputs, with 120-degree phase relationship, to create the sinusoidal current waveform as shown in Figure 2.

Protection features include lock detection with restart, motor output short circuit, supply undervoltage monitor, and thermal shutdown.

Standby mode can be achieved by holding SPD pin low for longer than the programmed Lock off-time. In specific speed curve options, the motor will never turn off with 0% duty cycle applied. In this type of configuration, standby mode is not available.

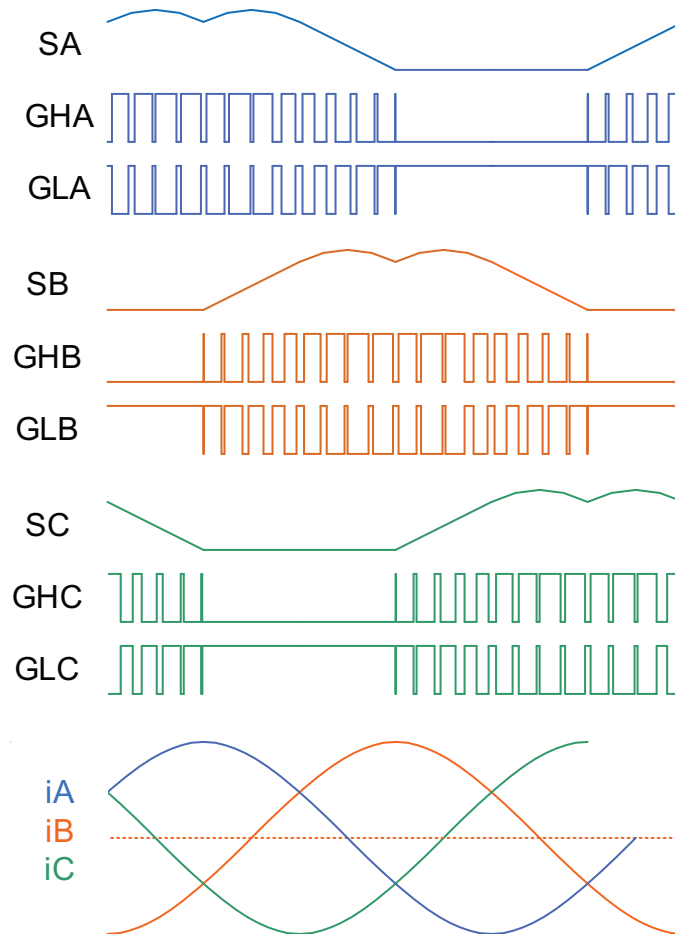

Figure 2: Sinusoidal PWM (DIR = HI)

**VREF.** Voltage reference (2.8 V) to power internal digital logic and analog circuitry. Stabilize with 0.1  $\mu$ F or greater ceramic capacitor. VREF can be used to power external circuitry with up to 20 mA bias current if desired. For high temperature applications, consider any added extra power dissipation due to regulator load.

$$P_{DISSBIAS} = V_{BB} \times (I_{BB} + I_{REFLOAD})$$

**FG.** Open drain output provides speed information to the system. The open drain output can be pulled up to  $V_{REF}$  or external 3.3 or 5 V supply.

The FG output signal typically represents two periods per mechanical revolution.  $f_{FGOUT}$  may not be same as electrical frequency:

$$f_{ELEC} = f_{FGOUT} \times \text{NumberOfPolePairs} / 2$$

$$f_{FGOUT} = f_{ELEC} \times 2 / \text{NumberOfPolePairs}$$

$$RPM = 30 \times f_{FGOUT}$$

$$RPM = f_{ELEC} \times 60 / \text{NumberOfPolePairs}$$

**RD.** Open drain output. Logic high indicates a rotor fault condition as defined by EEPROM variables. RD function can be disabled via EEPROM. When function is disabled, RD pin low to high transition indicates end of open-loop starting sequence.

**BRAKE.** Active-high signal turns on all low sides for braking function. Brake function will prevent IC from entering standby mode. Brake function overrides Speed control input. Care should be taken to avoid stress on the MOSFET when braking while motor is running. With braking, the current will be limited by  $V_{BEMF}/R_{MOTOR}$ .

BRAKE is pulled down internally with 100 k $\Omega$  resistor. To avoid any concern with PCB noise, it is recommended to connect pin to GND if brake function not used.

**DIR.** Logic Input to control motor direction. For logic high, motor phases are ordered A $\rightarrow$ B $\rightarrow$ C, and for logic low, A $\rightarrow$ C $\rightarrow$ B. If Direction input is changed while motor is running, motor will coast for a duration defined by  $t_{COAST}$ . After this delay, motor will then attempt to restart in desired direction.

DIR is pulled down internally with 100 k $\Omega$  resistor. To avoid any concern with PCB noise, it is recommended to connect pin to GND or VREF externally.

**ISET.** A resistor ( $R_{ISET}$ ) to GND sets the magnitude of gate current. The sink and source current ratios are fixed at approximately 2:1. Resistor value  $R_{ISET}$  should be in the range 15 to 60 k $\Omega$ .

The formula for gate drive current is as follows:

$$I_{GATE\_SRC} (\text{mA}) = 2.25 + 900 / R_{ISET} (\text{k}\Omega)$$

$$I_{GATE\_SNK} (\text{mA}) = 6.1 + 1666 / R_{ISET} (\text{k}\Omega)$$

If pin ISET is connected to GND, the circuit will default to a level equivalent to approximately 30 k $\Omega$ . If ISET is open, the motor outputs will be disabled.

**CTAP.** This analog input is an optional connection for motor common (Wye motors). If not used, as in case of Delta wound motor, then pin must be left open circuit.

**SPD.** Speed Demand input pin. Choice of analog voltage control or PWM duty control is determined by EEPROM selection.

*Duty cycle control.* The input Duty cycle signal is measured with logic circuit. The calculated output number is translated to a speed Demand signal with a resolution of 0.2%.

The maximum input PWM frequency is 100 kHz. To avoid interaction with the I<sup>2</sup>C circuitry, which share the FG and SPD inputs, the minimum PWM frequency may be limited based on the maximum frequency of the speed output pin FG.

$f_{PWM(\min)}$  is the larger number of  $2.5 \times f_{FGOUT(\max)}$  or 100 Hz.

$f_{FGOUT(\max)}$  is the maximum speed under all operating conditions.

Note:  $f_{FGOUT}$  (Hz) depends on selection of pole-pair in EEPROM, typically equals RPM / 30.

*Analog control.* Voltage applied will increase speed demand. An internal 9-bit A/D converter will translate the input to a speed demand.

$$\text{Code} = V_{IN(\text{SPD})} / 4.89 \text{ mV} + 3 \text{ where code} = [0 \dots 511]$$

$$\text{Applied Duty} (\%) = \text{Code} / 511.$$

**Standby Mode.** A low-power mode is activated if SPD pin is held low. Standby Mode will turn off all circuitry including charge pump and VREF. Upon power up, the A5932 will immediately wake up. If SPD remains low for the programmed lock time, standby mode will be activated. Standby mode can be disabled via EEPROM bit.

**Lock Detect.** A logic circuit monitors the motor position to determine if motor is running as expected. If a fault is detected, the motor drive will be disabled for  $t_{LOCK}$  before an auto-restart is attempted.

**OCP.** Overcurrent protection is intended to protect the IC from application conditions of shorted load, motor short to ground, and motor short to battery. The OCP protection monitors the drain to source voltage ( $V_{DS}$ ) across any source or sink driver when the output is turned on. The OCP level can be set to 1 V or 2 V via EEPROM bit VDSTH. If the OCP threshold is exceeded for

640 ns, all drivers are shut off. This fault mode can be reset by PWM ON/OFF or timeout of  $t_{LOCK}$ , depending on EEPROM bit OCPOPT.

**Current Limit.** Maximum load current can be set by choice of external sense resistor connected between LSS terminal and GND.

Current limit has an internal blanking filter of approximately 640 ns. Current limit function can be disabled by connecting LSS to power ground on the PCB.

$$I_{LIM} = V_{OCL} / R_{SENSE}$$

**Thermal Shutdown (TSD).** The A5932 protects itself from overheating with an internal thermal monitoring circuit. If the junction temperature exceeds the upper threshold  $T_{TSD}$ , the outputs will be disabled. Device temperature must fall below the hysteresis level,  $T_{HYS}$ , to allow a normal restart sequence.

**nFAULT.** The following signals will bring output nFAULT low:

1.  $V_{BB}$  undervoltage
2. Thermal shutdown
3. Charge pump UVLO
4.  $V_{BB}$  overvoltage
5. Output  $V_{DS}$  fault (OCP)
6. Loss of synchronization (rotor lock detected)

**Table 1: Fault Signals and Actions**

Fault	Fault Action	Latched	Readback / Reg[Bit]
$V_{BB}$ Undervoltage	Disable outputs	N	147[8]
TSD	Disable outputs	N	147[6]
Charge Pump	Disable outputs	N	147[7]
$V_{BB}$ Overvoltage	Disable outputs or disabled outputs and set Lock detect	N	147[9]
VDS Fault	Choose by EEPROM bit OCPOPT	if OCPOPT = 1	147[5:0]
Loss of Sync	Set Lock detect timeout	N	148[6:0]

SPEED CURVE PARAMETERS

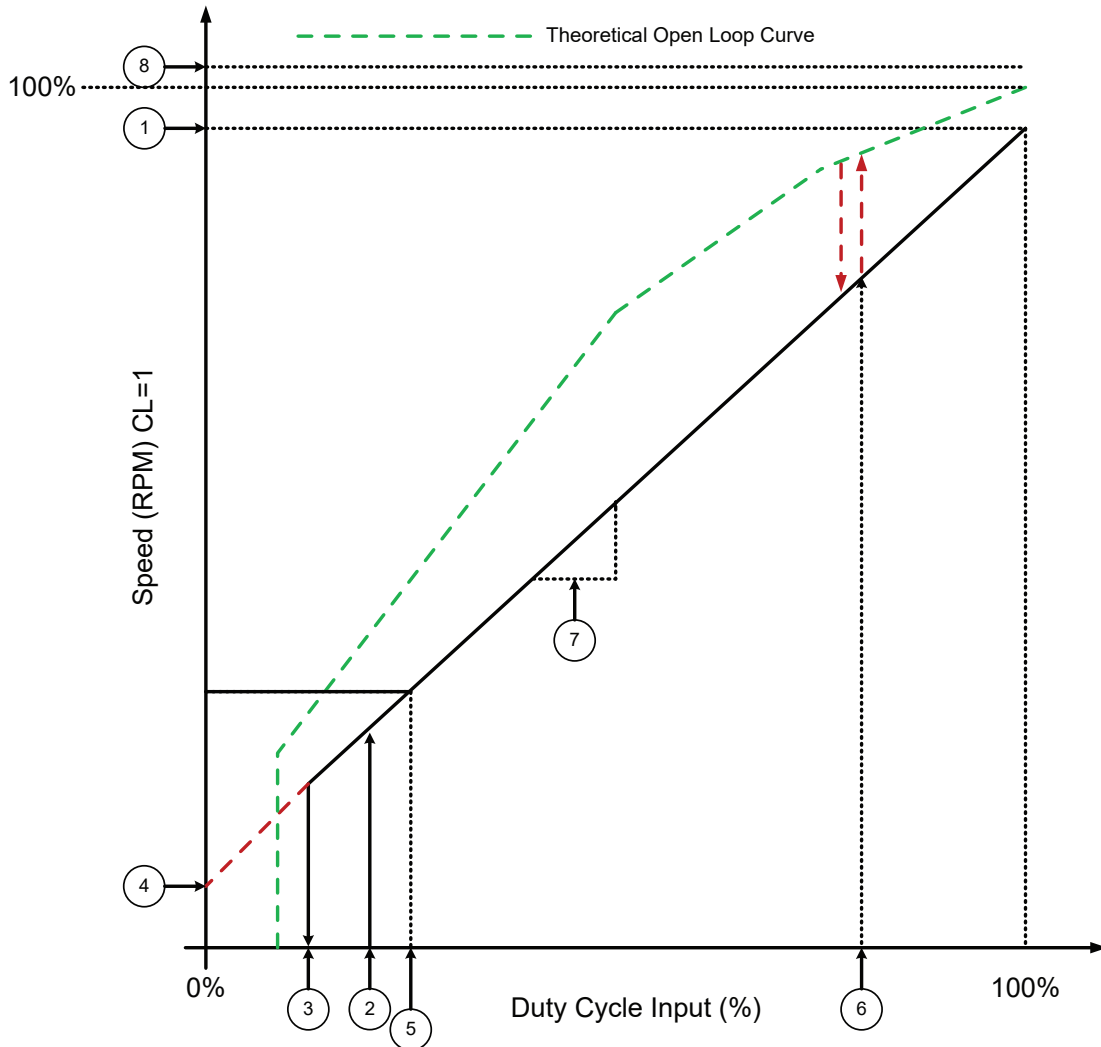

- ① Maximum Speed (calculated from Slope of line AND Offset)
- ② Duty On (DCON/511)
- ③ Duty Off (DCOFF/511)
- ④ MINSPD
- ⑤ Min Duty Clamp
- ⑥ Max Duty Threshold and Hysteresis
- ⑦ Slope (based on SPDSL variable)
- ⑧ OPNLPMAX

Figure 3: Speed Curve Options

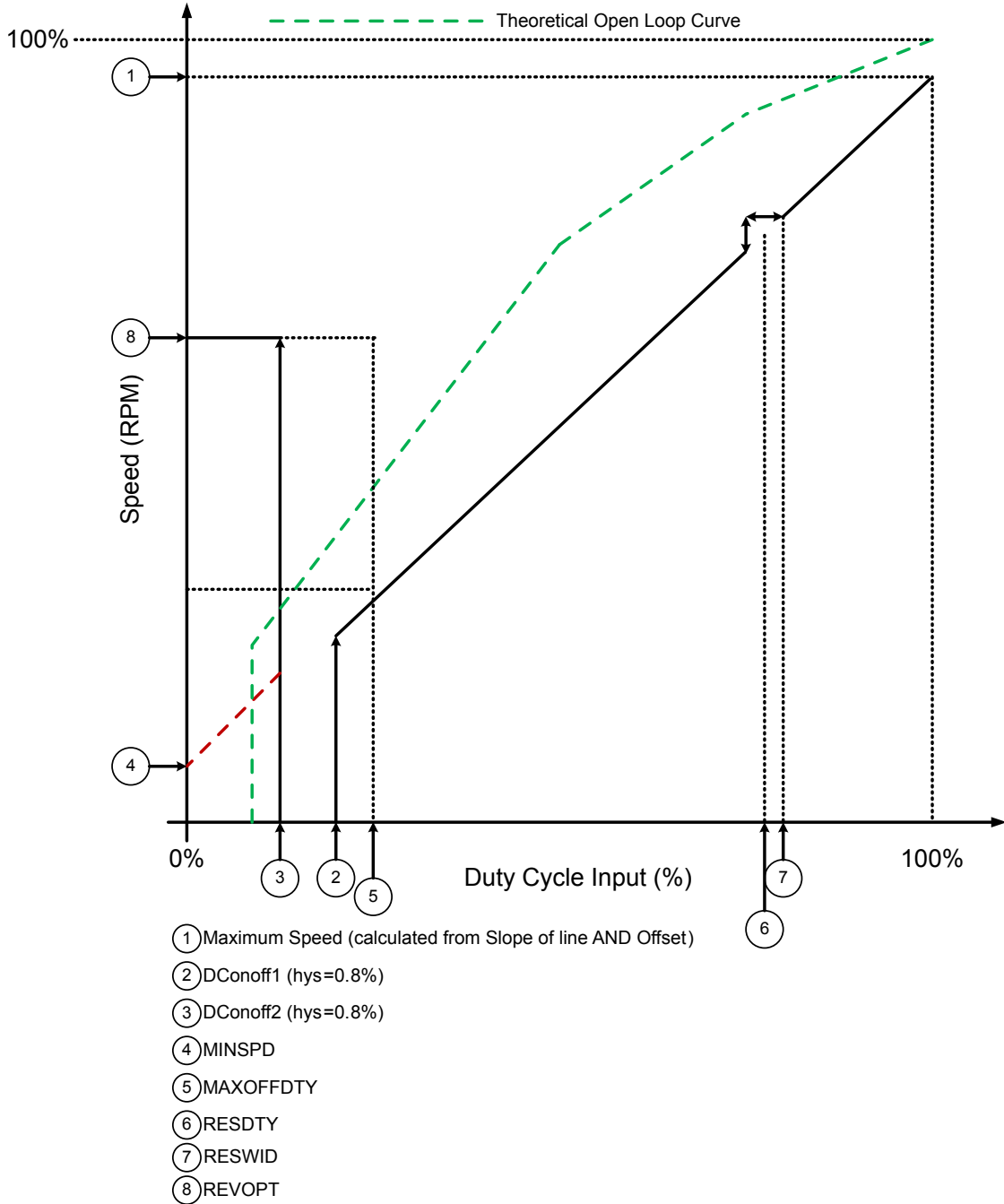

Figure 4: Speed Curve Options – 2

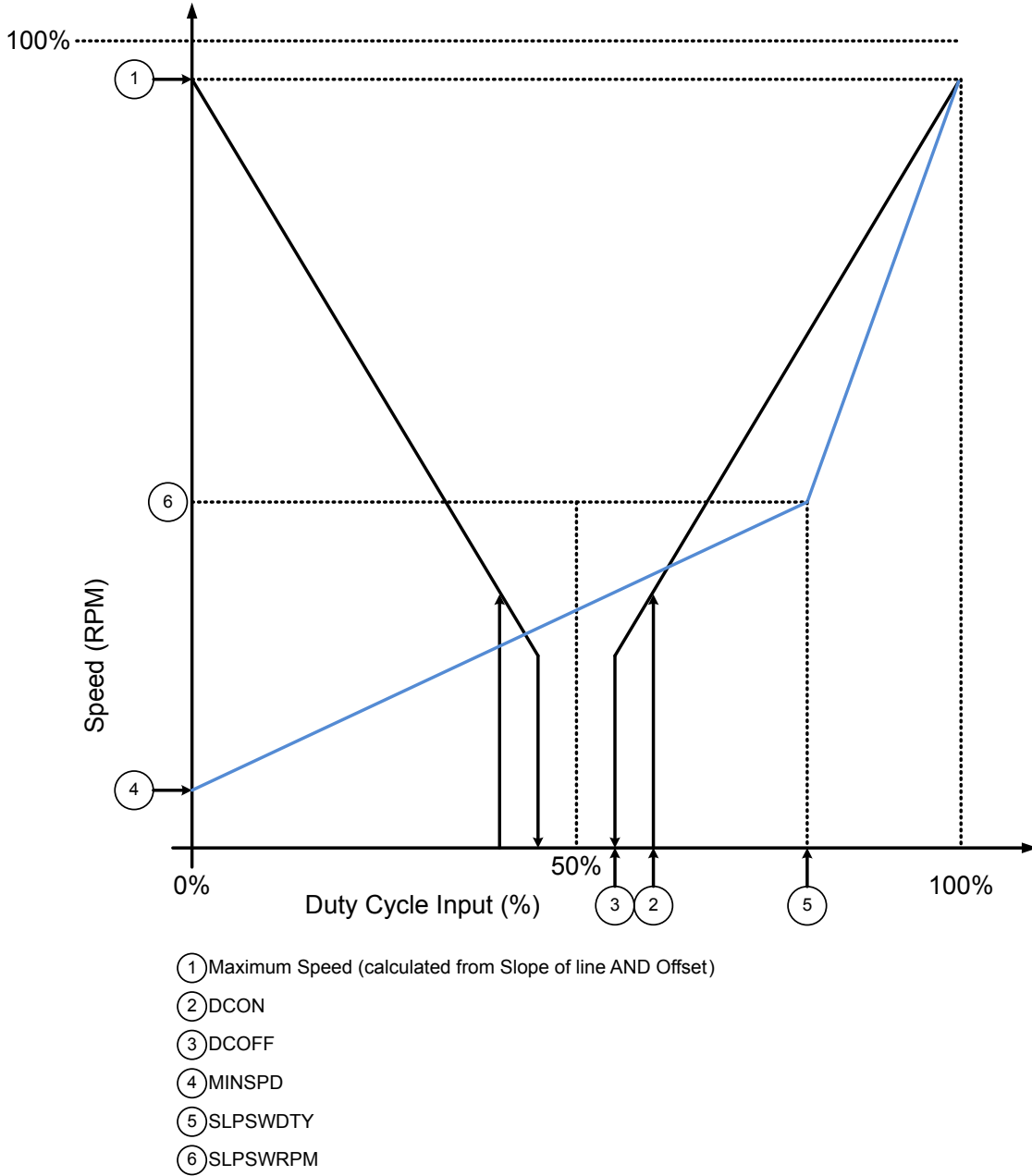

Figure 5: Speed Curve Options – 3

## Speed Curve Parameters

Refer to Figure 3, Figure 4, and Figure 5 for items below.

**Minimum Speed Setpoint.** The minimum speed is defined by the value stored in EEPROM variable MINSPD. The resolution is 1 rpm.

$$\text{MINSPD (rpm)} = 0..4095$$

**Maximum Speed Setpoint.** The A5932 calculates the maximum speed based on line equation  $y = mx + B$ . The maximum speed is defined as the speed with input duty = 100%.

The desired maximum speed is used to set the EEPROM variable SPDSLPL.

$$\text{SPDSLPL} = 64 \times (\text{Maximum Speed (rpm)} - \text{MINSPD}) / 511$$

Example: Max Speed = 25000, Min Speed = 3000.

$$\text{SPDSLPL} = 64 \times 22000 / 511 = 2755$$

where SPDSLPL = 0..16383

$$\text{Motor Speed (rpm)} = \text{Slope} \times \text{DutyIN} + \text{MINSPD.}$$

where Slope =  $\text{SPDSLPL} \times 511 / 64$  and DutyIN expressed in %.

**Duty-In Enable Threshold.** EEPROM variable DCON defines the input duty signal that enables the drive. DCON is an 8-bit number with resolution of 0.2%, which results in a maximum setting of 49.9%.

$$\text{Duty On (\%)} = 100 \times \text{DCON} / 511$$

If DCON is set to “0”, motor will turn on with 0% duty cycle input.

**Duty In Disable Threshold.** EEPROM variable DCOFF defines the input duty signal that disables the drive. DCOFF is an 8-bit number with resolution of 0.2%, which results in a maximum setting of 49.9%.

$$\text{Duty Off(\%)} = \text{DCOFF} / 511$$

DCOFF should always be set to a lower number than DCON.

**ON/Off Control Option.** If ONOFFCNTRL bit is set to “1”, then the motor will run if duty is between the values set by DCON and DCOFF. A fixed value of 0.8% hysteresis is applied. In this option, if the duty is below DCOFF, then the motor will be enabled with a PWM level set by variable MAXDTYOFF (see Figure 4).

Additionally, if duty is below DCOFF, the motor direction can be made to be reverse if REVOPT is set to “1”.

**Duty Cycle Invert.** To create mirror image of speed curve, set duty cycle invert bit to “1”.

**Minimum Duty Clamp.** Minimum speed can be clamped to a value to allow motor to run at defined low-level speed. This is achieved by ignoring the duty cycle input if below the programmed MINDTY level.

$$\text{Min Duty Clamp (\%)} = 100 \times \text{MINDTY} / 511$$

Therefore the minimum speed will be defined by:

$$\text{MinSpeedClamp(rpm)} = \text{Slope} \times \text{MinDutyClamp} + \text{MINSPD}$$

Setting MINDTY to 0 disables the function.

$$\text{MINDTY} = 0..255.$$

**Maximum Duty Clamp.** EEPROM variable DTYMAX defines a duty level at which the motor will change operation from closed-loop curve. The change of operation would depend on MAXDTYOPT setting. If MAXDTYOP = 0, open-loop operation will result. If MAXDTYOPT = 1, then operation will remain closed-loop; however, the speed will be clamped at the value calculated by DTYMAX level.

Four bits are used for this setting at resolution of 1.6% to cover the range 76.5% to 100%.

$$\text{Maximum Duty (\%)} = 100 \times (511 - \text{MAXDTY} \times 8) / 511$$

MAXDTY = 0..15; if MAXDTY = 0, then function is disabled.

Hysteresis is needed to prevent motor from going back and forth between open- and closed-loop mode.

$$\text{MAXDTYHYS} = 0..15.$$

$$\text{Hys(\%)} = (\text{MAXDTYHYS} + 1) \times 0.4$$

**50% Duty Option.** If bit DIR50 is set to 1, the motor direction can be controlled by duty cycle level (see Figure 5).

For this setting, the motor enable and disable functions will be set by:

$$\text{DCON}_{\text{new}} = 50\% \pm \text{DCON}$$

$$\text{DCOFF}_{\text{new}} = 50\% \pm \text{DCOFF}$$

Since the duty cycle reference changes from 100% scale to 50% scale, the slope of the curve is now 2× compared to normal (DIR50 = 0) setting. When duty changes to switch direction, the motor will coast for time programmed via TCOAST variable before attempting to startup in opposite direction. Care should be taken to minimize stress on the MOSFETs when switching direction.

**Dual Slope Option.** Two different slopes can be selected by setting variable SLPSWDTY greater than 0.

$$\text{Slope2} = (\text{MAXSPEED} - \text{SLPSWRPM}) / (100\% - \text{SLPSWDTY})$$

$$\text{Slope1} = (\text{SLPSWRPM} - \text{MINSPEED}) / \text{SLPSWDTY}$$

**Resonance Option** (see Figure 5). To avoid any issues with mechanical resonance at a particular speed band, variable RESWID and RESDTY are provided to allow skipping over a defined RPM.

RESDTY: defines duty cycle that is center of band.

RESWID: defines width of band relative to center duty value.

**Open Loop Maximum Limit.** When the speed curve is set to open loop mode, it is possible to limit the speed to prevent fan speed overshoot. RPM is monitored and the demand will be clamped at level that results in max limit.

OPNLPMAX variable has no effect in closed loop mode.

## EEPROM MAP

Table 2: EEPROM Map. Refer to application note and user interface for additional detail.

I <sup>2</sup> C Register	EEPROM Address	Bits	Name	Description	Default Setting	Default Value (decimal)
64	0	15:0	Dev1	Allegro Reserved	n/a	n/a
65	1	15:0	Dev1	Allegro Reserved	n/a	n/a
66	2	15:0	Dev1	Allegro Reserved	n/a	n/a
67	3	15:0	Dev1	Allegro Reserved	n/a	n/a
68	4	15:0	Dev1	Allegro Reserved	n/a	n/a
69	5	15:0	Dev1	Allegro Reserved	n/a	n/a
70	6	15:0	Dev1	Unused – Can be used by customer	n/a	n/a
71	7	15:0	Dev1	Unused – Can be used by customer	n/a	n/a
72	8	3:0	MAXDTYCLP	Range = 100% to 76.5%, LSB = 1.6%	0	0
		7:4	MAXDTYHYS	Range = 0 to 5.9%, LSB = 0.4%	0	0
		14:8	MINDTYCLP	Range = 0 to 49.7%, LSB = 0.4%	0	0
		15	Unused			
73	9	8:0	STRTDMD	LSB = VBBRNG / 511	0.8 V	17
		15:9	DMDPOST	Range = 0 to 100%, LSB = 0.8%	79.5%	202
74	10	7:0	ALIGNT	Range = 0 to 20.4 s, LSB = 100 ms	0.5 s	6
		15:8	ASLOPE	Range = 160 ms to 40 s	0.16 s	255
75	11	7:0	STRTF	Range = 0 to 15.94 Hz, LSB = 0.0625 mHz	0.19 Hz	3
		15:8	ACCEL	Range = 0 to 99.6 Hz/s, LSB = 0.78	41.8 Hz	107
76	12	7:0	ACCELT	Range = 0 to 10.2 s, LSB = 40 ms	480 ms	12
		15:8	MAXOFFDTY	Range = 100% to 76.5%, LSB = 0.4%	100%	0
77	13	3:0	DMDRMPAL	Range = 3.8 to 63.8 ms/count, LSB = 3.8	27.8 ms/count	6
		7:4	DMDRMPAH	Range = 3.8 to 63.8 ms/count, LSB = 3.8	15.8 ms/count	3
		11:8	DMDRMPDL	Range = 3.8 to 63.8 ms/count, LSB = 3.8	27.8 ms/count	6
		15:12	DMDRMPDH	Range = 3.8 to 63.8 ms/count, LSB = 3.8	27.8 ms/count	6
78	14	8:0	RESDTY	Range = 0 to 100%, LSB = 0.2%	Disabled	0
		15:9	RESWID	Range = 0 to 50%, LSB = 0.4%	n/a	0
79	15	7:0	MAXSPD	Maximum Electrical Frequency	509 Hz	24
		15:8	TLOCK	0 to 25.5 s	5 s	50
80	16	7:0	RDLOW	Range = 0 to 4095, LSB = 16 RPM	0	0
		15:8	RDHIGH	Range = 0 to 4095, LSB = 16 RPM	0	0
81	17	7:0	RDBLK	Range = 0 to 25.5 s, LSB = 100 ms	0	0
		11:8	RDDLTY	Range = 0 to 15 s, LSB = 1 s	0	0
		12	Unused			
		13	DITHDT	0 = 1.28 ms, 1 = 5.12 ms/step	0	0
		14	DITHSTP	0 = 16 steps, 1 = 32 steps	0	0
		15	DITHEHB	1 = Enable	disabled	0

Continued on next page...

## EEPROM MAP (continued)

I <sup>2</sup> C Register	EEPROM Address	Bits	Name	Description	Default Setting	Default Value (decimal)
82	18	11:0	PHASLP	Calculated Slope for Linear Phase Advance	12.7 degrees	98
		15:12	SOWLIN	Window Width With Linear Phase Advance	28.2 degrees	15
83	19	0	PCDLY	Post Coast delay 0 = 100 ms, 1 = 500 ms	500 ms	1
		1	STBYDIS	Standby Mode 0 = Enable, 1 = Disable	1	1
		3:2	PWMF	Motor PWM Selection	24/48 kHz	2
		5:4	BEMFFILT	Bemf comp filter	4 $\mu$ s	0
		6	TCENB	Temperature Compensation 0: Off, 1:On	0	0
		8:7	WINDM	Windmill Option	0	0
		12:9	SPDCLP	Minimum clamp is speed control mode	4.6%	2
		14:13	PHARNG	0: > 32 kRPM, 1: 16-32 kRPM, 2: 8-16 kRPM, 3: < 8 kRPM	8-16 kRPM	2
		15	OCLOPT	0 = Cycle by cycle, 1: Reduce demand	1	1
		84	20	0	CL	Speed Control Mode 0 = Open Loop, 1 = Closed
1	PHA			Running Mode 0 = Auto, 1=Linear Phase Advance	0	0
2	LOCKEVT			Rd Function Mode select	0	0
3	SPDSEL			Speed Control Select 0 = PWM Duty, 1 = Analog	0	0
6:4	PP			Pole Pair = PP + 1	2 pp	1
7	NOCOAST			1 = NOCOAST, 0 = Coast	No coast	1
8	ALIGNMODE			0 = Align, 1 = One Cycle	Align	0
9	QCKSTRT			0 = Disable, 1 = Enable	disable	0
10	OVPOPT			0 = Disable, 1 = Lock detect	TLOCK	1
11	FGSTRT			0 = FG disabled during Startup, 1 = FG Enabled	0	0
13:12	BEMFHYS			Bemf Hys Level for Startup	40 mV	1
14	SOWAUTO			Initial Value of Window	21°	1
15	OCPOPT			0 = Reset after TLOCK, 1 = After PWM on/off	TLOCK	0
85	21	7:0	KP	Closed Loop	16	16
		15:8	KI	Closed Loop	2	2
86	22	7:0	SLPSWDTY	Duty at which slope changes	Disabled	0
		14:8	TRAPSWDTY	Duty to switch to trap	Disabled	0
		15	TRAPENB	1 = Enable	Disabled	0
87	23	14:0	SLPSWRPM	Range 0 to 16384, LSB = 1 RPM	Disabled	0
88	24	13:0	SPDSL2	Calculated Slope	0	0
		15:14	Unused			

Continued on next page...

## EEPROM MAP (continued)

I <sup>2</sup> C Register	EEPROM Address	Bits	Name	Description	Default Setting	Default Value (decimal)
89	25	0	DUTYINV	0 = Normal, 1 = Invert	0	0
		1	MAXDYOPT	0 = Run at Open Loop, 1 = Run at MAXDYOCLP	0	0
		2	ONOFFCNTL	0 = Normal hysteretic on/off, 1 = Motor Off between DC_ON and DC_OFF	0	0
		3	DIR50	1 = enable direction change based on 50% duty	0	0
		4	REVOPT	1 = reverse when duty < dc_off and ONOFFCNTL = 1	0	0
		5	BRKOFF	0 = Coast, 1 = Brake when PWM off state after t <sub>COAST</sub>	0	0
		6	n/a	Set bit to 0	0	0
		8:7	PIOPT	0 = 1×, 1 = 2×, 2 = 4×, 4 = 8×	0	0
		15:9	Unused			
90	26	7:0	TCOAST	Coast time for brake or direction change	3 s	30
		15:8	OPNLPMAX	Max speed limit for open loop mode	30208	118
91	27	11:0	MINSPEED	Minimum Speed (y intercept)	1000	1000
		13:12	OVPSEL	18/28/38/48 V	28	1
		14	VBBRNG	0 = 24 V, 1 = 48 V	24	0
		15	Unused			
92	28	13:0	SPDSL1	Calculated Slope of Speed Curve	1378	1378
		15:14	Unused			
93	29	7:0	DCON	Range = 0 to 49.9%, LSB = 0.2%	10%	51
		15:8	DCOFF	Range = 0 to 49.9%, LSB = 0.2%	7.4%	38
94	30	3:0	DT	Deadtime	480 ns	10
		4	VDSTH	OCP VDS Threshold 0 = 1 V, 1 = 2 V	1 V	0
		5	OCPDIS	OCP Disable 0 = Enabled, 1 = Disabled	Enabled	0
		7:6	n/a	Allegro Reserved – set to 0	n/a	0
		15:8	n/a	Allegro Reserved – set to 0x59	n/a	89
95	31	15:0	n/a	Allegro Reserved	n/a	n/a

### SERIAL PORT CONTROL OPTION

Normally, the IC is controlled by duty cycle input and uses the EEPROM data that is stored to create the speed curve profile. However, it is possible to use direct serial port control to avoid programming EEPROM.

When using direct control, the input duty cycle command is replaced by writing a 9-bit number to register 165.

Example:

REGADDR[data]: (in decimal)

165[511] → Duty = 100%

165[102] → Duty = 102 / 511 = 20%

Upon power up, the IC defaults to duty cycle input mode. To use serial port mode, the internal registers should be programmed before turning the part on. The sequence to use serial port mode is:

1. Drive FG and SPD pins low.\*
2. Power-up IC.
3. Program registers for parameter setting that correspond to each of the EEPROM memory locations.
  - A. REGADDR = 64 + EEPROM ADDR.
  - B. Program register addresses 72 to 94 corresponding to EEPROM addresses 8 to 30.
  - C. It may be helpful to use the GUI text file to help define the hex data for each of the EEPROM addresses.
4. Write to register 165 to start motor.

\* Note: If SPD is not driven low before power up, motor will try to start immediately as the default high value will demand 100% on signal.

**Serial Port**

The A5932 uses standard fast mode I<sup>2</sup>C serial port format to program the EEPROM or to control the IC speed serially. The SPD pin functions as the clock (SCL) input, and the FG pin is the data line (SDA). No special sequence is needed to begin transferring data. If the motor is running, the FG pin may then pull the data line low while trying to initialize into serial port mode. Once an I<sup>2</sup>C command is sent, the SPD input is ignored and the motor will turn off as if a PWM duty command of 0% was sent.

The A5932 7-bit slave address is 0x55.

**I<sup>2</sup>C Timing Diagrams**

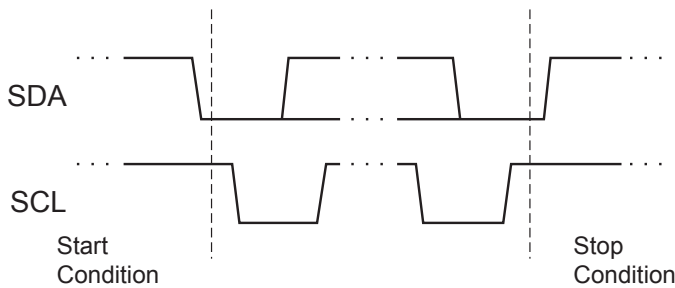

Figure 6: Start and Stop Conditions

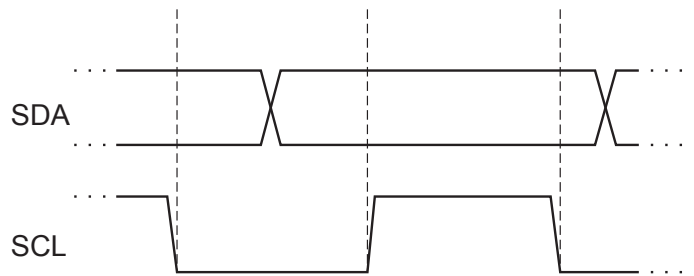

Figure 7: Clock and Data Bit Synchronization

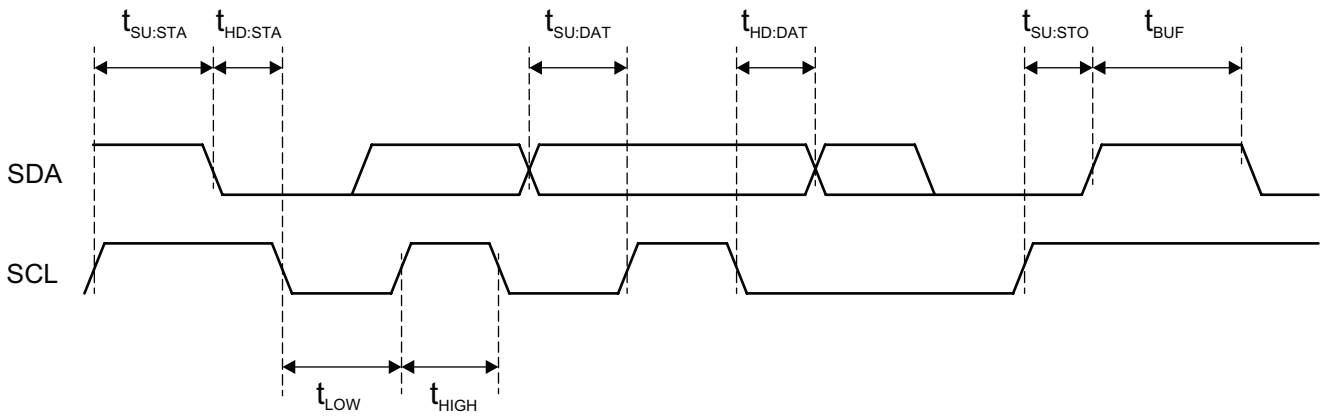

Figure 8: I<sup>2</sup>C-Compatible Timing Requirements

## Write Command

1. Start Condition
2. 7-bit I<sup>2</sup>C Slave Address (Device ID) 1010101, R/W Bit = 0
3. Internal Register Address
4. 2 data bytes, MSB first
5. Stop Condition

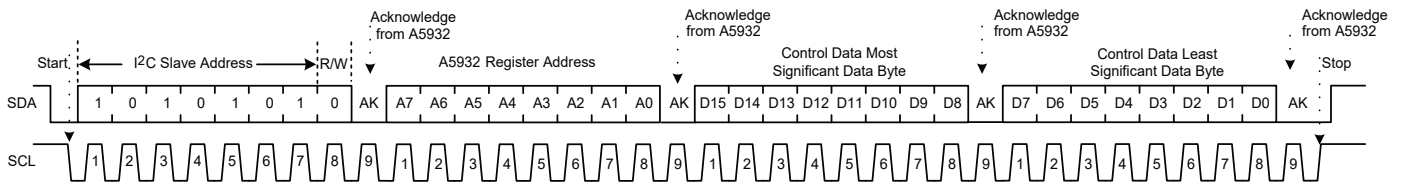

Figure 9: Write Command

## Read Command

1. Start Condition
2. 7-bit I<sup>2</sup>C Slave Address (Device ID) 1010101, R/W Bit = 0
3. Internal Register Address to be read
4. Stop Condition
5. Start Condition
6. 7-bit I<sup>2</sup>C Slave Address (Device ID) 1010101, R/W Bit = 1
7. Read 2 data bytes
8. Stop Condition

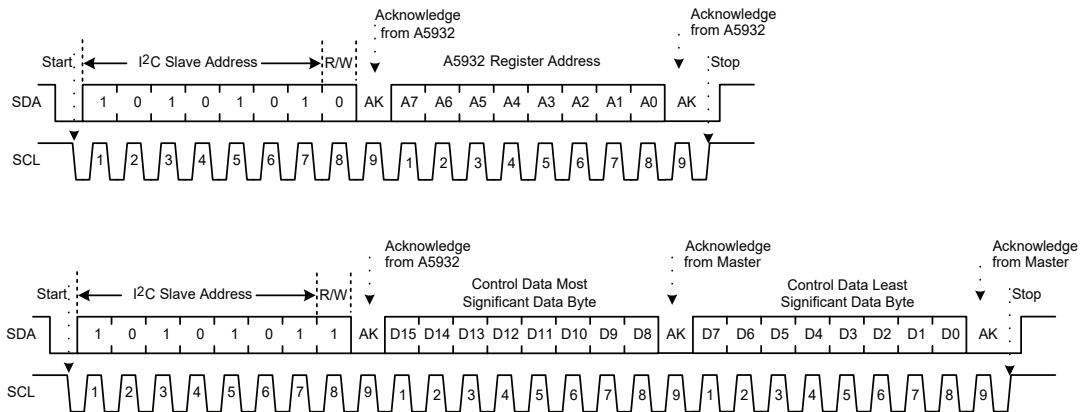

Figure 10: Read Command

## Programming EEPROM

The A5932 contains 32 words of 16-bit length. The EEPROM is controlled with the following I<sup>2</sup>C registers. Refer to application note for EEPROM definition.

**Table 3: EEPROM Control – Register 161 (Used to control programming of EEPROM)**

15	14	13	12	11	10	9	8	7	6	5	4	3	2	1	0
0	0	0	0	0	0	0	0	0	0	0	0	RD	WR	ER	EN
Bit	Name	Description													
0	EN	Set EEPROM voltage required for writing or erasing													
1	ER	Sets mode to erase													
2	WR	Sets mode to write													
3	RD	Sets mode to read													
15:4	n/a	Do not use; always set to zero during programming process													

**Table 4: EEPROM Address – Register 162 (Used to set the EEPROM address to be altered)**

15	14	13	12	11	10	9	8	7	6	5	4	3	2	1	0
0	0	0	0	0	0	0	0	0	0	0	eeADDRESS				
Bit	Name	Description													
4:0	eeADDRESS	Used to specify EEPROM address to be changed.													
15:5	n/a	Do not use; always set to zero during programming process													

**Table 5: EEPROM DataIn – Register 163 (Used to set the EEPROM new data to be programmed)**

15	14	13	12	11	10	9	8	7	6	5	4	3	2	1	0
eeDATAIn															
Bit	Name	Description													
15:0	eeDATAIn	Used to specify the new EEPROM data to be changed													

**Table 6: DataOUT – Register 164 (Used for read operations)**

15	14	13	12	11	10	9	8	7	6	5	4	3	2	1	0
eeDATAout															
Bit	Name	Description													
15:0	eeDATAout	Used to readback EEPROM data from address defined in register 162													

There are 3 basic commands: Read, Erase, and Write. To change the contents of a memory location, the word must be first erased. The EEPROM programming process (writing or erasing) takes 10 ms per word.

Each word must be written individually.

Example #1: Write EEPROM address 5 to 261 (0x0105)

1) Erase the word

- ```

I2C Write REGADDR[Data] ; comment
a. 162[5] ; set EEPROM address to erase
b. 163[0] ; set 0000 as Data In
c. 161[3] ; set control to Erase and trigger high-voltage pulse
d. Wait 15 ms ; wait for pulse to end
e. 161[0] ; clear voltage

```

2) Write the new data

- ```

a. 162[5] ; set EEPROM address to write
b. 163[261] ; set Data In = 261
c. 161[5] ; set control to Write and trigger high-voltage pulse
d. Wait 15 ms ; wait for pulse to end
e. 161[5] ; clear voltage

```

Example #2: Read EEPROM address 5 to confirm correct data properly programmed

1) Read the word

- ```

a. 5[I2C Read] ; read register 5; this will be the contents of EEPROM

```

PIN DIAGRAMS

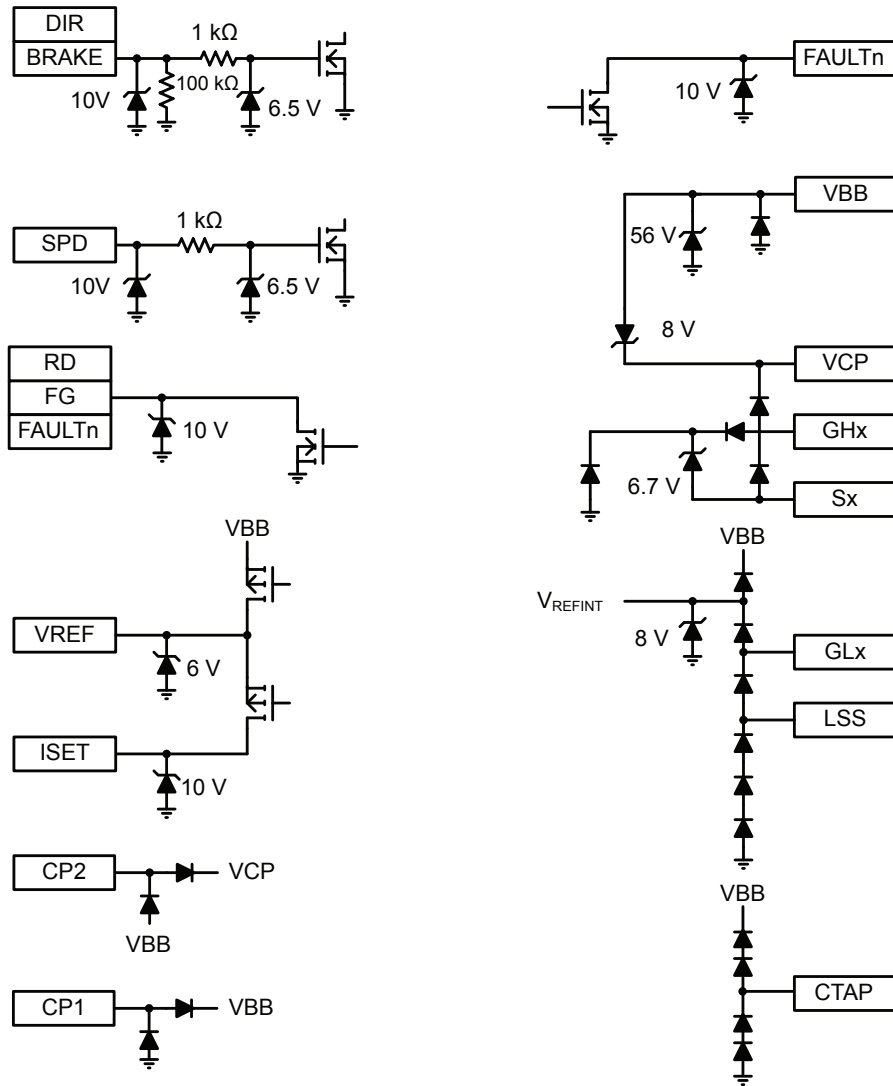

Figure 11: Pin Diagrams

**PACKAGE OUTLINE DRAWING**

**For Reference Only – Not for Tooling Use**

(Reference Allegro DWG-0000222 Rev. 4 or JEDEC MO-220WGGD.)

Dimensions in millimeters – NOT TO SCALE.

Exact case and lead configuration at supplier discretion within limits shown.

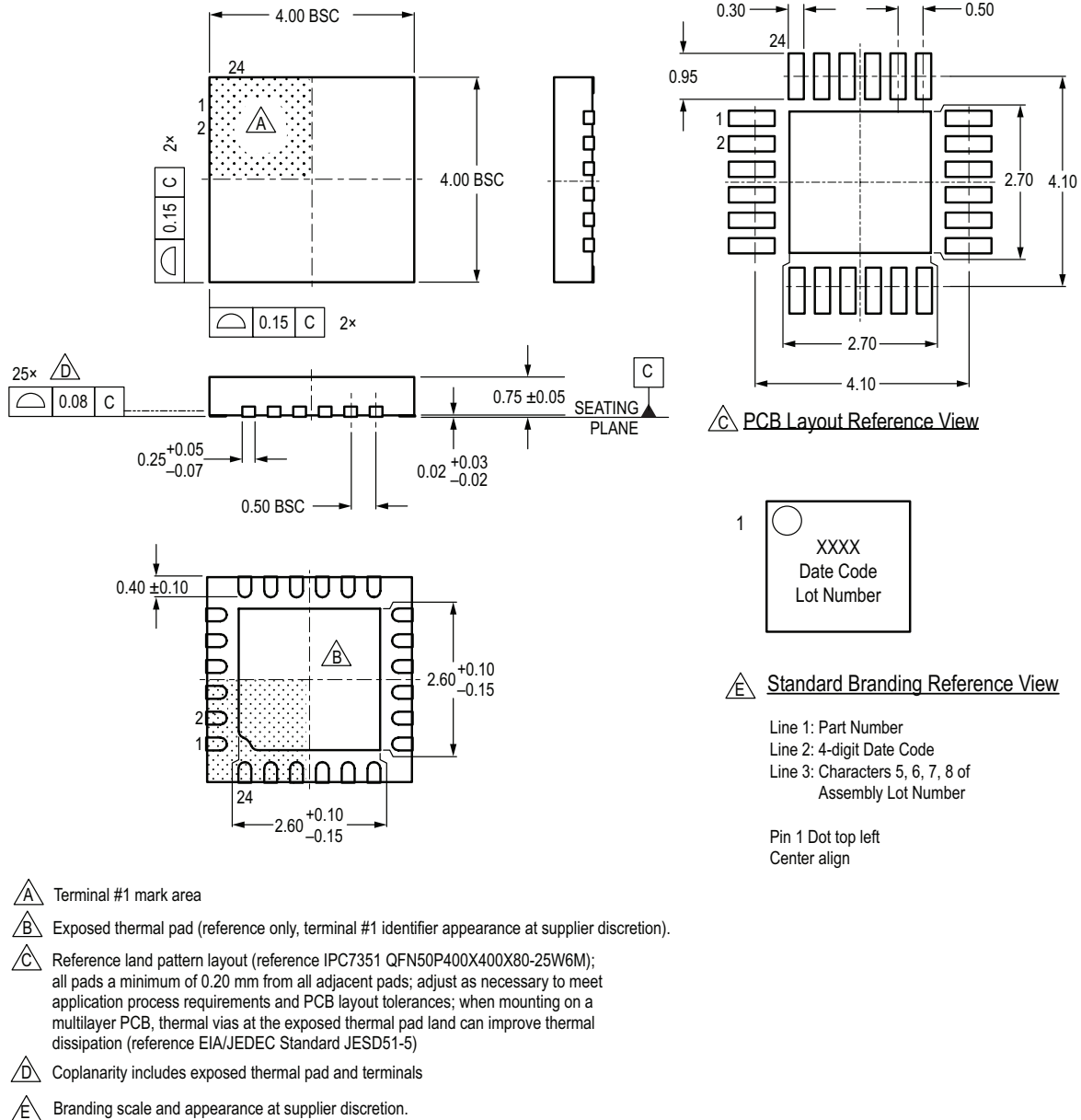

**Figure 12: Package ES, 24-Contact QFN with Exposed Pad**

### For Reference Only – Not for Tooling Use

(Reference Allegro DWG-0000222 Rev. 6 or JEDEC MO-220WGGD)

Dimensions in millimeters – NOT TO SCALE.

Exact case and lead configuration at supplier discretion within limits shown.

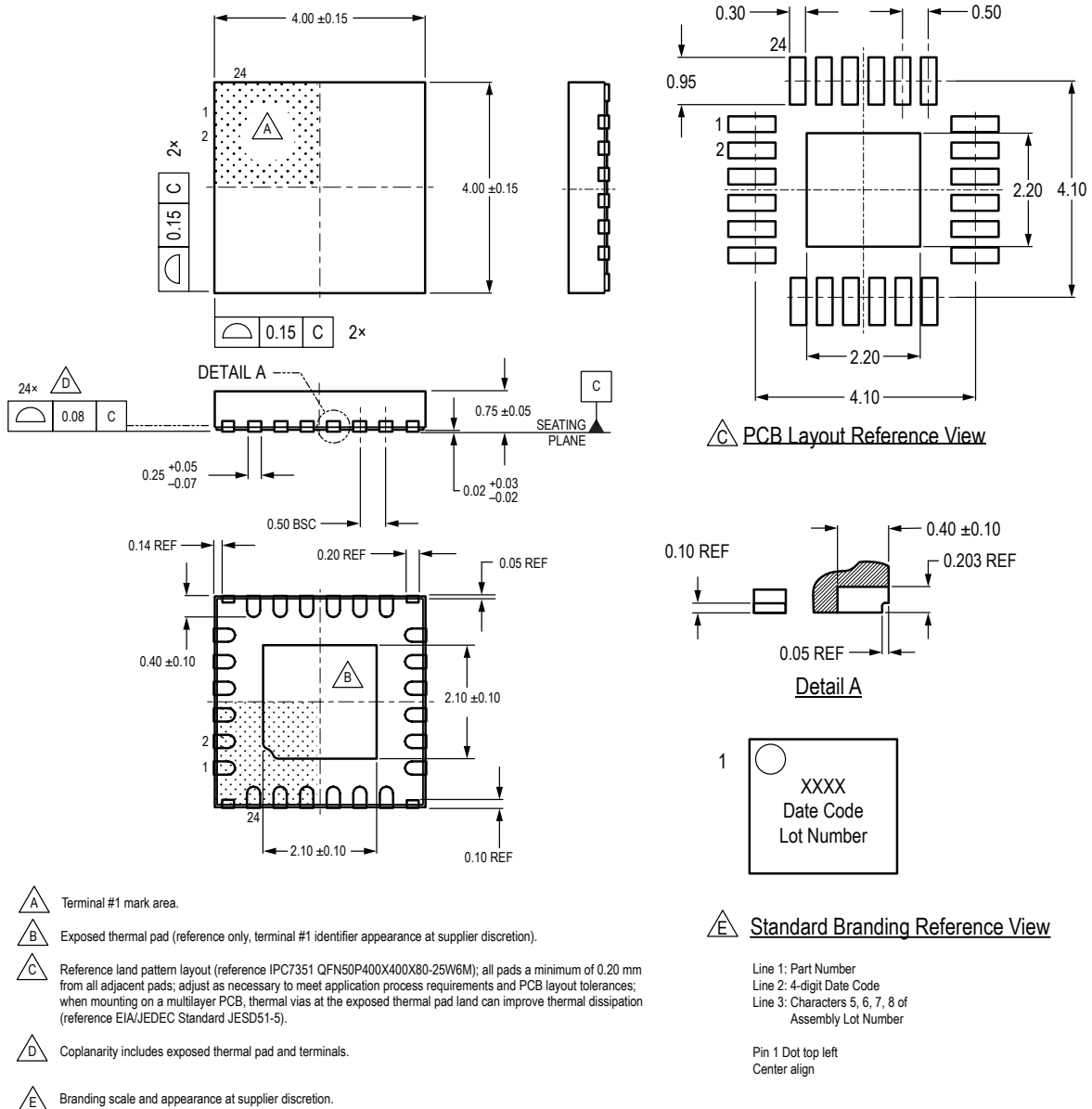

Figure 13: Package ES, -J option, 24-Contact QFN Wettable Flank with Exposed Pad

**For Reference Only – Not for Tooling Use**

(Reference Allegro DWG-0000379, Rev. 3 and JEDEC MO-153ADT)  
NOT TO SCALE

Dimensions in millimeters

Dimensions exclusive of mold flash, gate burrs, and dambar protrusions  
Exact case and lead configuration at supplier discretion within limits shown

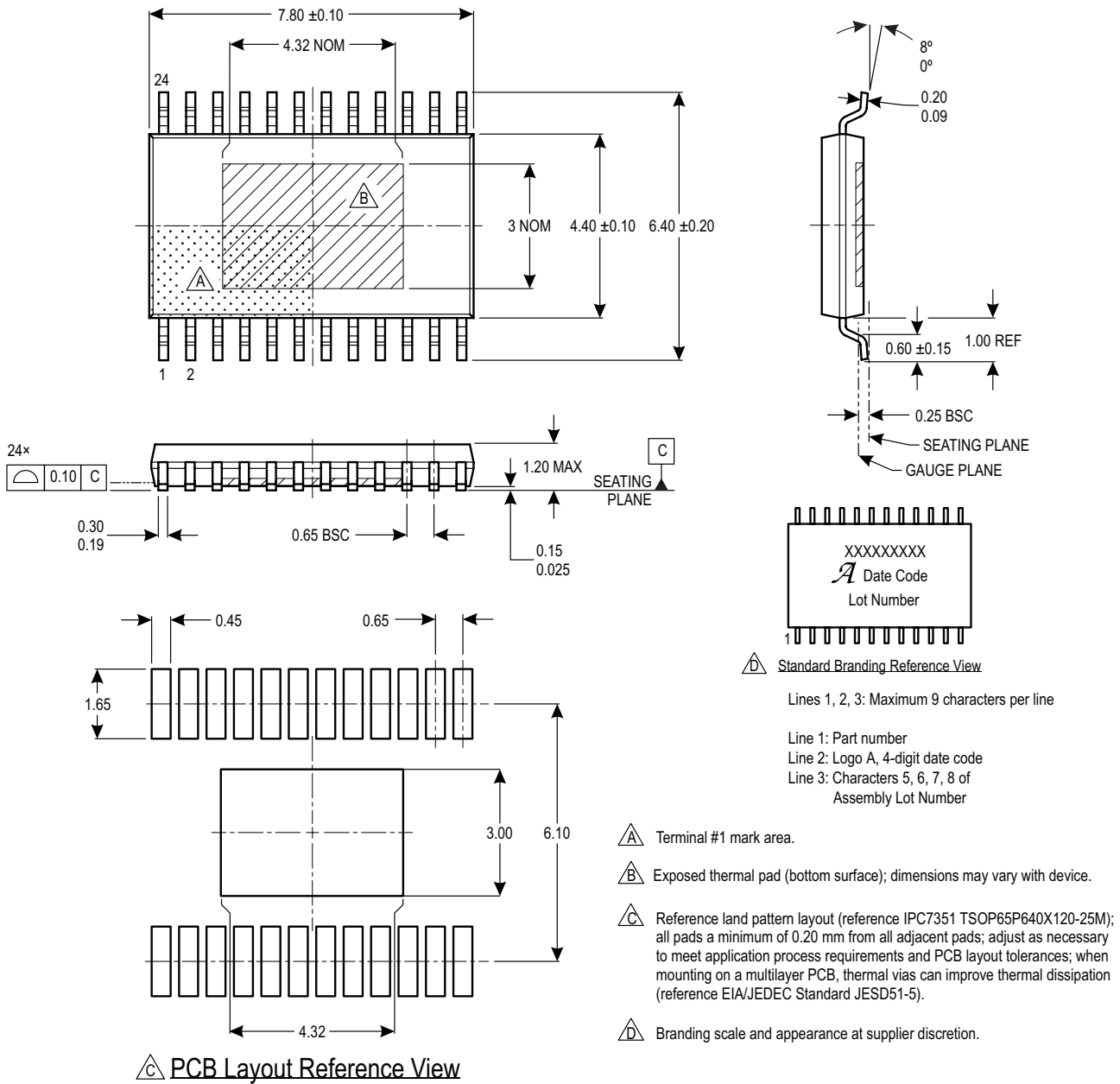

Figure 14: Package LP, 24-Lead TSSOP with Exposed Pad

**Revision History**

| Number | Date              | Description                                                                                                                                                                                |
|--------|-------------------|--------------------------------------------------------------------------------------------------------------------------------------------------------------------------------------------|
| –      | June 19, 2017     | Initial release                                                                                                                                                                            |
| 1      | December 12, 2017 | Added automotive temperature range part variant, wettable flank package option                                                                                                             |
| 2      | October 24, 2018  | Updated PWM Input Frequency Range min value (page 5), FG and SPD functional description sections (page 8); minor editorial updates                                                         |
| 3      | November 2, 2018  | Updated PWM Input Frequency Range (page 5), VREG, BRAKE, and DIR functional description sections (page 8); added Thermal Shutdown functional description (page 9); minor editorial updates |
| 4      | November 15, 2018 | Updated VREF and SPD functional description sections (page 8).                                                                                                                             |
| 5      | July 25, 2019     | Minor editorial updates; initial release to web                                                                                                                                            |
| 6      | July 21, 2022     | Updated package drawings (pages 24-26)                                                                                                                                                     |

Copyright 2022, Allegro MicroSystems.

Allegro MicroSystems reserves the right to make, from time to time, such departures from the detail specifications as may be required to permit improvements in the performance, reliability, or manufacturability of its products. Before placing an order, the user is cautioned to verify that the information being relied upon is current.

Allegro's products are not to be used in any devices or systems, including but not limited to life support devices or systems, in which a failure of Allegro's product can reasonably be expected to cause bodily harm.

The information included herein is believed to be accurate and reliable. However, Allegro MicroSystems assumes no responsibility for its use; nor for any infringement of patents or other rights of third parties which may result from its use.



Copies of this document are considered uncontrolled documents.

For the latest version of this document, visit our website:

[www.allegromicro.com](http://www.allegromicro.com)

## Looking for pricing, stock, or lifecycle information?

Click below to explore more details on WIN SOURCE:

-  [View A5932GESSR-T on WIN SOURCE](#)
-  [Allegro MicroSystems, LLC Information](#)

## Optimize Your Supply Chain with WIN SOURCE Solutions

-  Global Sourcing Solution
-  Obsolete Management
-  Cost Control Management
-  Shortage Management
-  Alternative Solution
-  Excess Inventory Management