



THE DATASHEET OF IRMCF183M





High Performance Sensorless Motor Control IC

Description

IRMCF183M is a high performance Flash based motion control IC designed and optimized for low cost appliance control which contains two computation engines integrated into one monolithic chip. One is the Flexible Motion Control Engine (MCE™) for sensorless control of permanent magnet motors or induction motors; the other is an 8-bit high-speed microcontroller (8051). The user can program a motion control algorithm by connecting these control elements using a graphic compiler. Key components of the complex sensorless control algorithms, such as the Angle Estimator, are provided as complete pre-defined control blocks. A unique analog/digital circuit and algorithm fully supports single shunt or leg shunt current reconstruction. IRMCF183M comes in a 32 pin 5x5 QFN package.

Features

- MCE™ (Flexible Motion Control Engine) - Dedicated computation engine for high efficiency sinusoidal sensorless motor control
- Built-in hardware peripheral for single or two shunt current feedback reconstruction and analog circuits
- Embedded 8-bit high speed microcontroller (8051) for flexible I/O and man-machine control
- JTAG programming port for emulation/debugger
- Serial communication interface (UART)
- Watchdog timer with independent internal clock
- Internal 64Kbyte Flash
- 3.3V single supply

Product Summary

Maximum clock input (f_{crystal})	60 MHz
Maximum Internal clock (SYSCLK)	120MHz
Maximum 8051 clock (8051CLK)	30MHz
MCE™ computation data range	16 bit signed
8051 Program Flash	52KB
8051/MCE Data RAM	4KB
MCE Program RAM	12KB
GateKill latency (digital filtered)	2 μ sec
PWM carrier frequency	20 bits/ SYSCLK
A/D input channels	4
A/D converter resolution	12 bits
A/D converter conversion speed	2 μ sec
Analog output (PWM) resolution	8 bits
UART baud rate (typ)	57.6K bps
Number of digital I/O (max)	7
Package (lead free)	QFN 5x5 32L
Typical 3.3V operating current	30mA

Base Part Number	Package Type	Standard Pack		Orderable Part Number
		Form	Quantity	
IRMCF183M	QFN32	Tape and Reel	3000	IRMCF183MTR
		Tray	3120	IRMCF183M

Table of Contents

1	Overview	5
2	Pinout	6
3	IRMCF183M Block Diagram and Main Functions	7
4	Application connection and Pin function	9
4.1	8051 Peripheral Interface Group	9
4.2	Motion Peripheral Interface Group.....	10
4.3	Analog Interface Group	10
4.4	Power Interface Group	11
4.5	Test Interface Group	11
5	DC Characteristics.....	12
5.1	Absolute Maximum Ratings.....	12
5.2	System Clock Frequency and Power Consumption	12
5.3	Digital I/O DC Characteristics.....	13
5.4	Analog I/O (IFBU+,IFBU-,IFBUO, IFBV+,IFBV-,IFBVO) DC Characteristics.....	14
5.5	Under Voltage Lockout DC characteristics	15
5.6	Itrip comparator DC characteristics	15
6	AC Characteristics.....	16
6.1	Digital PLL AC Characteristics	16
6.2	Analog to Digital Converter AC Characteristics	17
6.3	Op amp AC Characteristics.....	18
6.4	SYNC to SVPWM and A/D Conversion AC Timing.....	19
6.5	GATEKILL to SVPWM AC Timing	20
6.6	Itrip AC Timing	20
6.7	UART AC Timing.....	21
6.8	Interrupt AC Timing	22
6.9	JTAG AC Timing	23
7	I/O Structure	24
8	Pin List	27
9	Package Dimensions	29
10	Part Marking Information.....	30
11	Qualification Information	30

List of Tables

Table 1 Absolute Maximum Ratings.....	12
Table 2 System Clock Frequency	12
Table 3 Digital I/O DC Characteristics.....	13
Table 4 Analog I/O DC Characteristics.....	14
Table 5 UVcc DC Characteristics.....	15
Table 6 Itrip DC Characteristics	15
Table 7 PLL AC Characteristics	16
Table 8 A/D Converter AC Characteristics	17
Table 9 Current Sensing OP Amp AC Characteristics.....	18
Table 10 SYNC AC Characteristics.....	19
Table 11 GATEKILL to SVPWM AC Timing	20
Table 12 Itrip AC Timing	20
Table 13 UART AC Timing.....	21
Table 14. Interrupt AC Timing	22
Table 15 JTAG AC Timing	23
Table 16 Pin List.....	28

List of Figures

Figure 1 Typical Application Block Diagram Using IRMCF183M	5
Figure 2 Pinout of IRMCF183M.....	6
Figure 3 Crystal circuit example	16
Figure 4 Voltage droop and S/H hold time.....	17
Figure 5 A capacitor of 47pF is recommended at the output pin of all op amps.....	18
Figure 6 SYNC timing	19
Figure 7 Gatekill timing	20
Figure 8 ITRIP timing	20
Figure 9 UART timing.....	21
Figure 10. Interrupt timing	22
Figure 11 JTAG timing	23
Figure 12 PWMUL/PWMUH/PWMVL/PWMVH/PWMWL/PMMWH output	24
Figure 13 All digital I/O except motor PWM output	24
Figure 14 RESET, GATEKILL I/O	25
Figure 15 Analog input.....	25
Figure 16 Analog operational amplifier output and AREF I/O structure	25
Figure 17 VPP programming pin I/O structure.....	26
Figure 18 VSS and AVSS pin structure.....	26
Figure 19 VDD1 and VDDCAP pin structure	26
Figure 20 XTAL0/XTAL1 pins structure.....	26

1 Overview

IRMCF183M is a new generation International Rectifier integrated circuit device primarily designed as a one-chip solution for complete inverter controlled appliance motor control applications. Unlike a traditional microcontroller or DSP, the IRMCF183M provides a built-in closed loop sensorless control algorithm using the unique flexible Motion Control Engine (MCE™) for permanent magnet motors as well as induction motors. The MCE™ consists of a collection of control elements, motion peripherals, a dedicated motion control sequencer and dual port RAM to map internal signal nodes. IRMCF183M also employs a unique single shunt current reconstruction circuit in addition to two leg shunt current sensing circuit to eliminate additional analog/digital circuitry and enables a direct shunt resistor interface to the IC. Motion control programming is achieved using a dedicated graphical compiler integrated into the MATLAB/Simulink™ development environment. Sequencing, user interface, host communication, and upper layer control tasks can be implemented in the 8051 high-speed 8-bit microcontroller. The 8051 microcontroller is equipped with a JTAG port to facilitate emulation and debugging tools. Figure 1 shows a typical application schematic using the IRMCF183M.

IRMCF183M is available in a 32-pin QFN package.

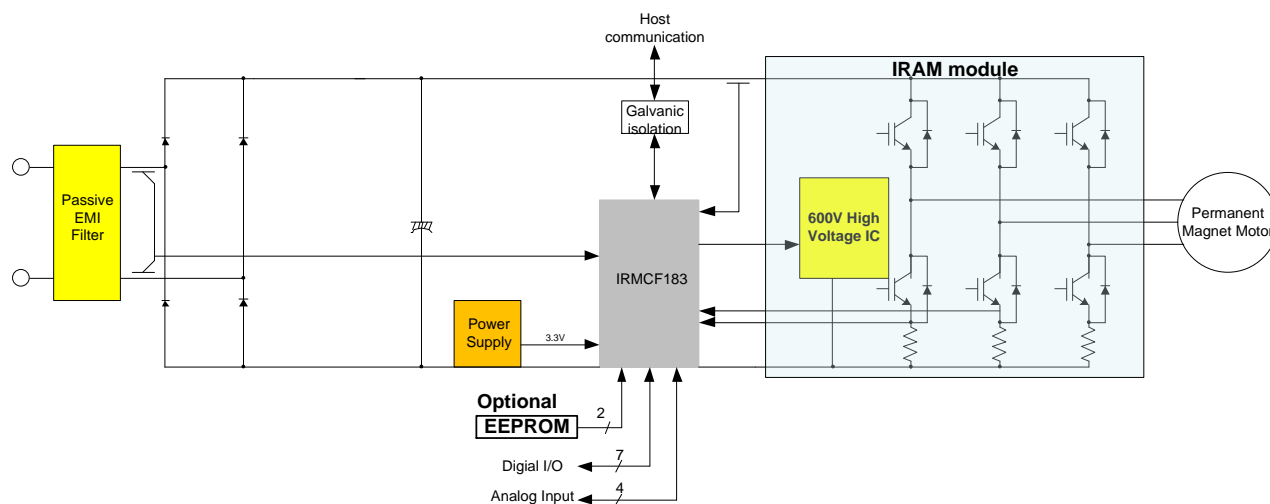

Figure 1 Typical Application Block Diagram Using IRMCF183M

2 Pinout

Pin out shown is based on QFN 5x5 32 pin package.

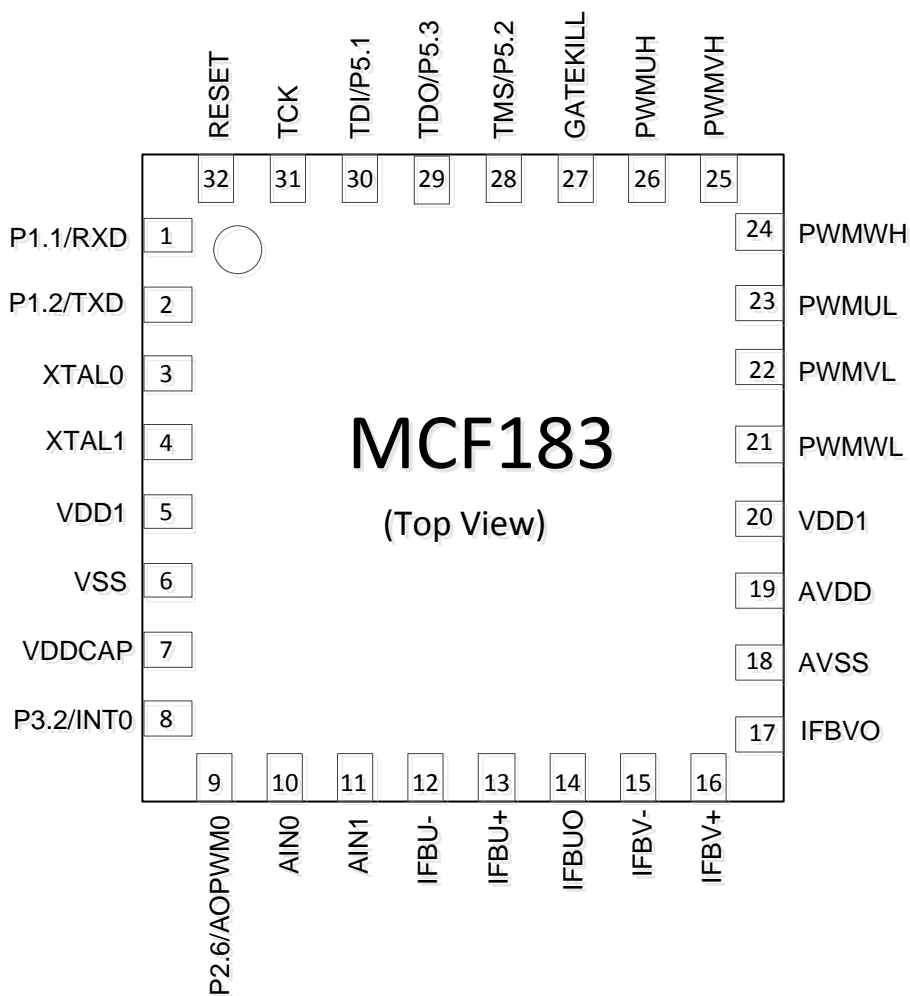

Figure 2 Pinout of IRMCF183M

3 IRMCF183M Block Diagram and Main Functions

IRMCF183M block diagram is shown in Figure 3.

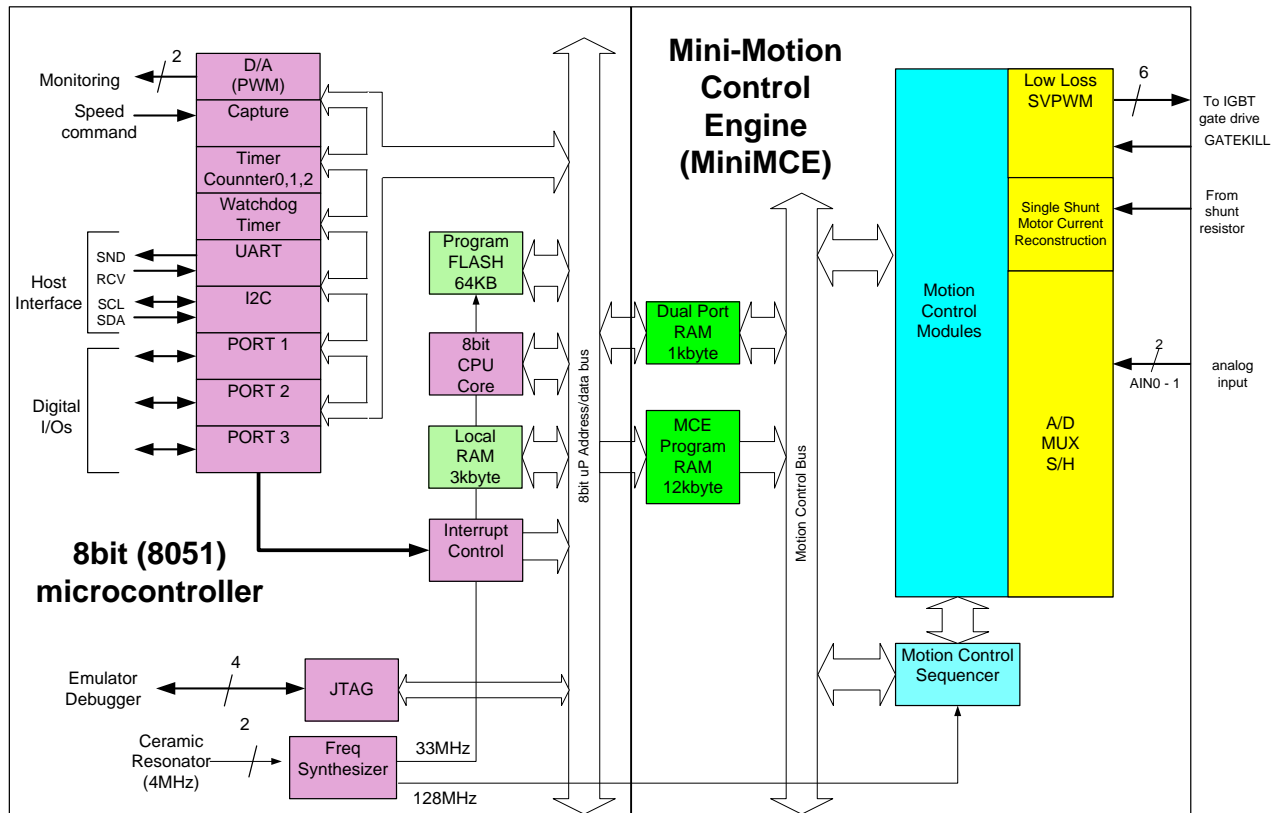

Figure 3 IRMCF183M Block Diagram

IRMCF183M contains the following functions for sensorless AC motor control applications:

- Motion Control Engine (MCE™)
 - Sensorless FOC (complete sensorless field oriented control)
 - Proportional plus Integral block
 - Low pass filter
 - Differentiator and lag (high pass filter)
 - Ramp
 - Limit
 - Angle estimate (sensorless control)

- Inverse Clark transformation
- Vector rotator
- Bit latch
- Peak detect
- Transition
- Multiply-divide (signed and unsigned)
- Divide (signed and unsigned)
- Adder
- Subtractor
- Comparator
- Counter
- Accumulator
- Switch
- Shift
- ATAN (arc tangent)
- Function block (any curve fitting, nonlinear function)
- 16 bit wide Logic operations (AND, OR, XOR, NOT, NEGATE)
- MCE™ program memory and dual port RAM (max 12K+2k byte)
- MCE™ control sequencer
- 8051 microcontroller
 - Two 16 bit timer/counters
 - One 16 bit periodic timer
 - One 16 bit watchdog timer
 - One 16 bit capture timer
 - Up to 7 discrete I/Os
 - 4 channel 12 bit A/D
 - Buffered (current sensing) two channels (0 – 1.2V input)
 - Unbuffered two channels (0 – 1.2V input)
 - JTAG port (4 pins)
 - Up to three channels of analog output (8 bit PWM)
 - UART
 - 32K byte OTP program ROM
 - 2K byte data RAM

4 Application connection and Pin function

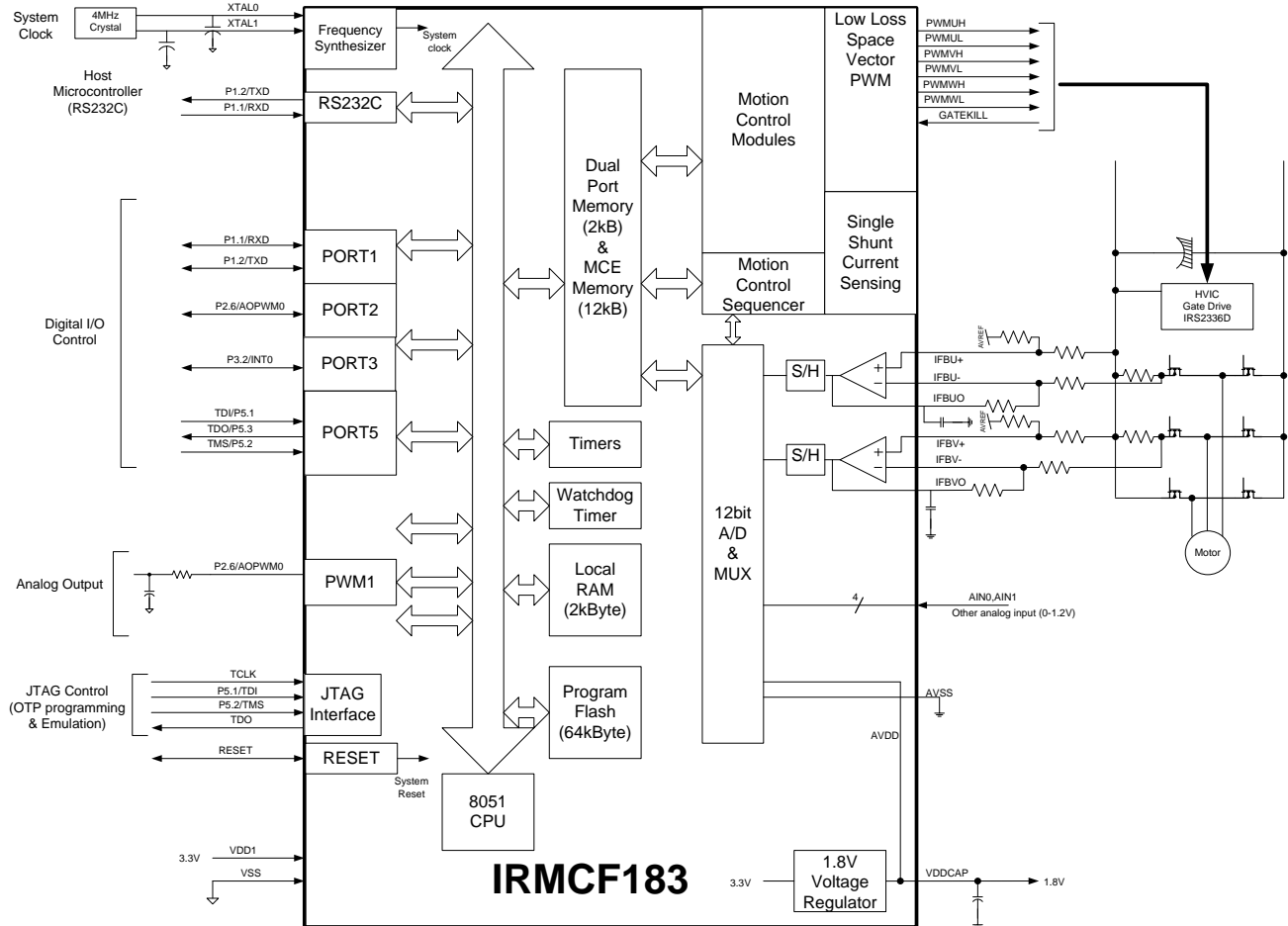

Figure 4 IRMCF183M Connection Diagram

4.1 8051 Peripheral Interface Group

UART Interface

P1.2/TXD	Output, Transmit data from IRMCF183M
P1.1/RXD	Input, Receive data to IRMCF183M

Discrete I/O Interface

P1.1/RXD	Input/output port 1.1, can be configured as RXD input
P1.2/TXD	Input/output port 1.2, can be configured as TXD output
P2.6/AOPWM0	Input/output port 2.6, can be configured as AOPWM0 output
P3.2/INT0	Input/output port 3.2, can be configured as INT0 input

P5.1/TDI Input port 5.1, configured as JTAG port by default
P5.2/TMS Input port 5.2, configured as JTAG port by default

Analog Output Interface

P2.6/AOPWM0 Input/output, can be configured as 8-bit PWM output 0 with programmable carrier frequency
P2.7/AOPWM1 Input/output, can be configured as 8-bit PWM output 1 with programmable carrier frequency

Crystal Interface

XTAL0 Input, connected to crystal
XTAL1 Output, connected to crystal

Reset Interface

RESET Input and Output, system reset, doesn't require external RC time constant

4.2 Motion Peripheral Interface Group

PWM

PWMUH Output, PWM phase U high side gate signal, internally pulled down by 58kΩ
PWMUL Output, PWM phase U low side gate signal, internally pulled down by 58kΩ
PWMVH Output, PWM phase V high side gate signal, internally pulled down by 58kΩ
PWMVL Output, PWM phase V low side gate signal, internally pulled down by 58kΩ
PWMWH Output, PWM phase W high side gate signal, internally pulled down by 58kΩ
PWMWL Output, PWM phase W low side gate signal, internally pulled down by 58kΩ

Fault

GATEKILL Input, upon assertion, this negates all six PWM signals, active low, internally pulled up by 70kΩ

4.3 Analog Interface Group

AVSS Analog power return, (analog internal 1.8V power is shared with VDDCAP)
IFBU+ Input, Operational amplifier positive input for single or U-phase leg shunt resistor current sensing
IFBU- Input, Operational amplifier negative input for single or U-phase leg shunt shunt resistor current sensing
IFBUO Output, Operational amplifier output for single or U-phase leg shunt shunt resistor current sensing
IFBV+ Input, Operational amplifier positive input for V-phase leg shunt resistor current sensing
IFBV- Input, Operational amplifier negative input for V-phase leg shunt shunt resistor current sensing

IFBVO	Output, Operational amplifier output for V-phase leg shunt resistor current sensing
AIN0	Input, Analog input channel 0 (0 – 1.2V), typically configured for DC bus voltage input
AIN1	Input, Analog input channel 1 (0 – 1.2V), needs to be pulled down to AVSS if unused

4.4 Power Interface Group

VDD1	Digital power (3.3V)
AVDD	Analog Power (1.8V)
VDDCAP	Internal 1.8V output, requires capacitors to the pin. Shared with analog power pad internally Note: The internal 1.8V supply is not designed to power any external circuits or devices. Only capacitors should be connected to this pin.
VSS	Digital common

4.5 Test Interface Group

P5.2/TMS	JTAG test mode input or input/output digital port
TDO	JTAG data output
P5.1/TDI	JTAG data input, or input/output digital port
TCK	JTAG test clock

5 DC Characteristics

5.1 Absolute Maximum Ratings

Symbol	Parameter	Min	Typ	Max	Condition
V _{DD1}	Supply Voltage	-0.3 V	-	3.6 V	Respect to VSS
V _{IA}	Analog Input Voltage	-0.3 V	-	1.98 V	Respect to AVSS
V _{ID}	Digital Input Voltage	-0.3 V	-	6.0 V	Respect to VSS
V _{PP}	OTP Programming voltage	-0.3V	-	7.0V	Respect to VSS
T _A	Ambient Temperature	-40 °C	-	125 °C	
T _S	Storage Temperature	-65 °C	-	150 °C	

Table 1 Absolute Maximum Ratings

Caution: Stresses beyond those listed in “Absolute Maximum Ratings” may cause permanent damage to the device. These are stress ratings only and function of the device at these or any other conditions beyond those indicated in the operational sections of the specifications are not implied.

5.2 System Clock Frequency and Power Consumption

C_{AREF} = 1nF, C_{MEXT} = 100nF. VDD1=3.3V, Unless specified, Ta = 25°C.

Symbol	Parameter	Min	Typ	Max	Unit
SYCLK	System Clock	32	-	128	MHz
P _D	Power consumption		160 ¹⁾	200	mW

Table 2 System Clock Frequency

Note 1) The value is based on the condition of MCE clock=126MHz, 8051 clock 31.5MHz with an actual motor running by a typical MCE application program and 8051 code.

5.3 Digital I/O DC Characteristics

Symbol	Parameter	Min	Typ	Max	Condition
V_{DD1}	Supply Voltage	3.0 V	3.3 V	3.6 V	Recommended
V_{PP}	OTP Programming voltage	6.70V	6.75V	6.80V	Recommended
V_{IL}	Input Low Voltage	-0.3 V	-	0.8 V	Recommended
V_{IH}	Input High Voltage	2.0 V		3.6 V	Recommended
C_{IN}	Input capacitance	-	3.6 pF	-	⁽¹⁾
I_L	Input leakage current		± 10 nA	± 1 μ A	$V_O = 3.3$ V or 0 V
$I_{OL2}^{(2)}$	Low level output current	17.9 mA	26.3 mA	33.4 mA	$V_{OL} = 0.4$ V ⁽¹⁾
$I_{OH2}^{(2)}$	High level output current	24.6 mA	49.5 mA	81 mA	$V_{OH} = 2.4$ V ⁽¹⁾

Table 3 Digital I/O DC Characteristics

Note:

- (1) Data guaranteed by design.
- (2) Applied to all digital I/O pins.

5.4 Analog I/O (IFBU+,IFBU-,IFBUO, IFBV+,IFBV-,IFBVO) DC Characteristics

$C_{AREF} = 1\text{nF}$, $C_{MEXT} = 100\text{nF}$. $V_{DD1} = 3.3\text{V}$, Unless specified, $T_a = 25^\circ\text{C}$.

Symbol	Parameter	Min	Typ	Max	Condition
V_{AVDD}	AVDD voltage	1.71V	1.80V	1.89V	
V_{OFFSET}	Input Offset Voltage	-	-	26 mV	
V_I	Input Voltage Range	0 V		1.2 V	Recommended
V_{OUTSW}	OP amp output operating range	50 mV ⁽¹⁾	-	1.7 V	
C_{IN}	Input capacitance	-	3.6 pF	-	⁽¹⁾
R_{FDBK}	OP amp feedback resistor	5 k Ω	-	20 k Ω	Requested between IFBO and IFB-
OP_{GAINCL}	Operating Close loop Gain	80 db	-	-	⁽¹⁾
CMRR	Common Mode Rejection Ratio	-	80 db	-	⁽¹⁾
I_{SRC}	Op amp output source current	-	1 mA	-	$V_{OUT} = 0.6\text{ V}$ ⁽¹⁾
I_{SNK}	Op amp output sink current	-	100 μA	-	$V_{OUT} = 0.6\text{ V}$ ⁽¹⁾

Table 4 Analog I/O DC Characteristics

Note:

(1) Data guaranteed by design.

5.5 Under Voltage Lockout DC characteristics

Unless specified, Ta = 25°C.

Symbol	Parameter	Min	Typ	Max	Condition
UV _{CC+}	UVcc positive going Threshold	2.78 V	3.04 V	3.23 V	(1)
UV _{CC-}	UVcc negative going Threshold	2.78 V	2.97 V	3.23 V	
UV _{CCH}	UVcc Hysteresys	-	73 mV	-	(1)

Table 5 UVcc DC Characteristics

Note:

(1) Data guaranteed by design.

5.6 Itrip comparator DC characteristics

Unless specified, VDD1=3.3V, Ta = 25°C.

Symbol	Parameter	Min	Typ	Max	Condition
Itrip ₊	Itrip positive going Threshold	-	1.22V	-	
Itrip ₋	Itrip negative going Threshold	-	1.10V	-	
ItripH	Itrip Hysteresys	-	120mV	-	

Table 6 Itrip DC Characteristics

6 AC Characteristics

6.1 Digital PLL AC Characteristics

Symbol	Parameter	Min	Typ	Max	Condition
F_{CLKIN}	Crystal input frequency	3.2 MHz	4 MHz	60 MHz	⁽¹⁾ (see figure below)
F_{PLL}	Internal clock frequency	32 MHz	50 MHz	128 MHz	⁽¹⁾
F_{LWPPW}	Sleep mode output frequency	$F_{CLKIN} \div 256$	-	-	⁽¹⁾
J_S	Short time jitter	-	200 psec	-	⁽¹⁾
D	Duty cycle	-	50 %	-	⁽¹⁾
T_{LOCK}	PLL lock time	-	-	500 μ sec	⁽¹⁾

Table 7 PLL AC Characteristics

Note:

(1) Data guaranteed by design.

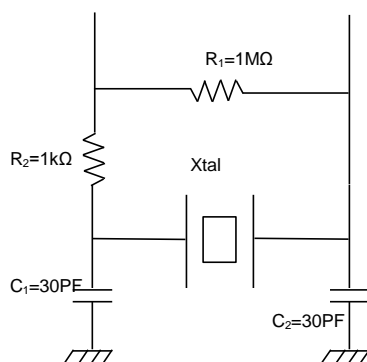

Figure 3 Crystal circuit example

6.2 Analog to Digital Converter AC Characteristics

Unless specified, $T_a = 25^\circ\text{C}$.

Symbol	Parameter	Min	Typ	Max	Condition
T_{CONV}	Conversion time	-	-	2.05 μsec	(1)
T_{HOLD}	Sample/Hold maximum hold time	-	-	10 μsec	Voltage droop ≤ 15 LSB (see figure below)

Table 8 A/D Converter AC Characteristics

Note:

(1) Data guaranteed by design.

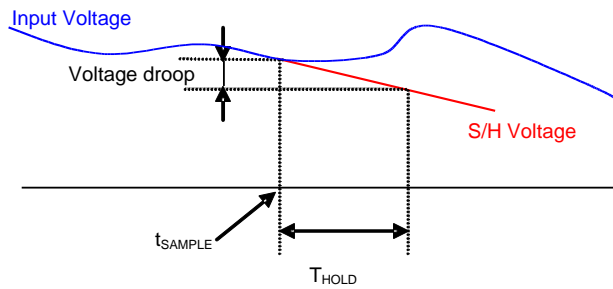

Figure 4 Voltage droop and S/H hold time

6.3 Op amp AC Characteristics

Unless specified, Ta = 25°C.

Symbol	Parameter	Min	Typ	Max	Condition
OP _{SR}	OP amp slew rate	-	10 V/μsec	-	VDD1 = 3.3 V, CL = 33 pF ⁽¹⁾
OP _{IMP}	OP input impedance	-	10 ⁸ Ω	-	⁽¹⁾ ⁽²⁾
T _{SET}	Settling time	-	400 ns	-	VDD1 = 3.3 V, CL = 33 pF ⁽¹⁾

Table 9 Current Sensing OP Amp AC Characteristics

Note:

- (1) Data guaranteed by design.
- (2) To guarantee stability of the operational amplifier, it is recommended to load the output pin by a capacitor of 47pF, see Figure 5. Here only the single shunt current amplifier is show but all op amp outputs should be loaded with this capacitor.

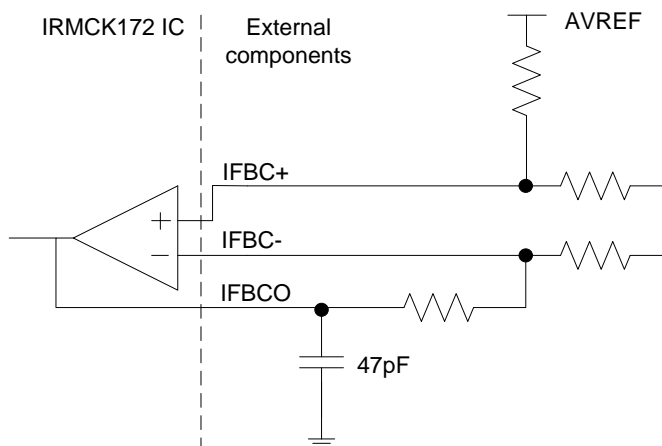

Figure 5 A capacitor of 47pF is recommended at the output pin of all op amps.

6.4 SYNC to SVPWM and A/D Conversion AC Timing

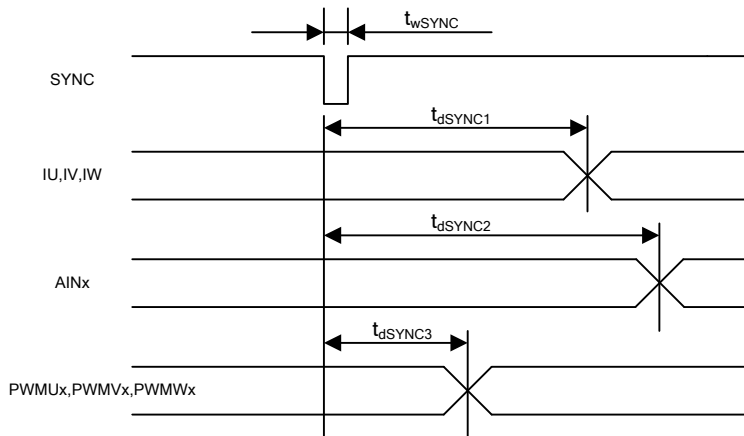

Figure 6 SYNC timing

Unless specified, Ta = 25°C.

Symbol	Parameter	Min	Typ	Max	Unit
$t_{w\text{SYNC}}$	SYNC pulse width	-	32	-	SYSCCLK
$t_{d\text{SYNC}1}$	SYNC to current feedback conversion time	-	-	100	SYSCCLK
$t_{d\text{SYNC}2}$	SYNC to AIN0-5 analog input conversion time	-	-	200	SYSCCLK ⁽¹⁾
$t_{d\text{SYNC}3}$	SYNC to PWM output delay time	-	-	2	SYSCCLK

Table 10 SYNC AC Characteristics

Note:

(1) AIN1 channel is converted once every 6 SYNC events

6.5 GATEKILL to SVPWM AC Timing

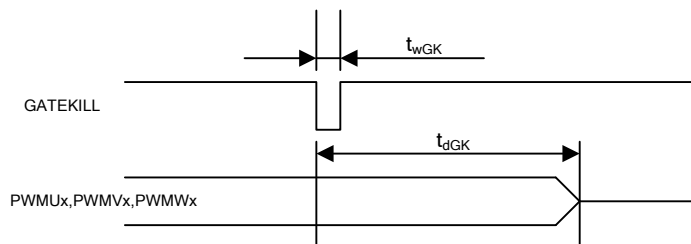

Figure 7 Gatekill timing

Unless specified, Ta = 25°C.

Symbol	Parameter	Min	Typ	Max	Unit
t_{wGK}	GATEKILL pulse width	32	-	-	SYSCCLK
t_{dGK}	GATEKILL to PWM output delay	-	-	100	SYSCCLK

Table 11 GATEKILL to SVPWM AC Timing

6.6 Itrip AC Timing

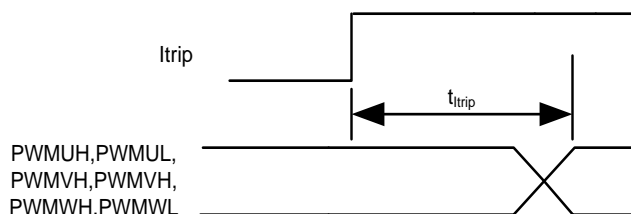

Figure 8 ITRIP timing

Unless specified, Ta = 25°C.

Symbol	Parameter	Min	Typ	Max	Unit
t_{ITRIP}	Itrip propagation delay	-	-	100(sysclk)+1.0usec	SYSCCLK+usec

Table 12 Itrip AC Timing

6.7 UART AC Timing

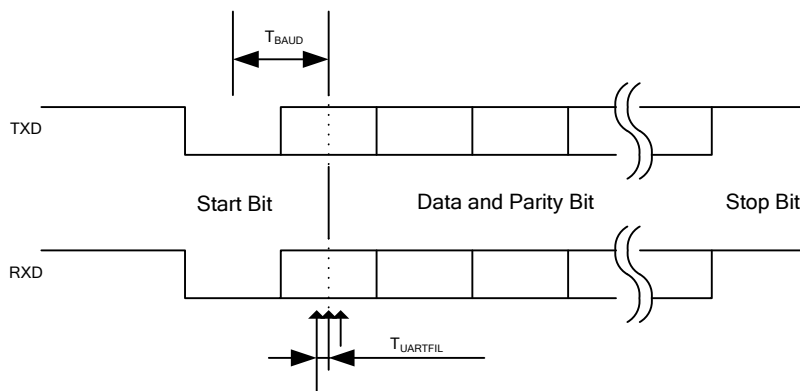

Figure 9 UART timing

Unless specified, $T_a = 25^\circ\text{C}$.

Symbol	Parameter	Min	Typ	Max	Unit
T_{BAUD}	Baud Rate Period	-	57600	-	bit/sec
T_{UARTFIL}	UART sampling filter period ⁽¹⁾	-	1/16	-	T_{BAUD}

Table 13 UART AC Timing

Note:

- (1) Each bit including start and stop bit is sampled three times at center of a bit at an interval of 1/16 T_{BAUD} . If three sampled values do not agree, then UART noise error is generated.

6.8 Interrupt AC Timing

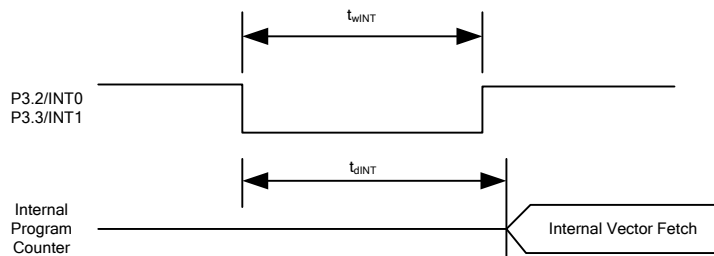

Figure 10. Interrupt timing

Unless specified, Ta = 25°C.

Symbol	Parameter	Min	Typ	Max	Unit
t_{wINT}	INT0, INT1 Interrupt Assertion Time	4	-	-	SYSCCLK
t_{dINT}	INT0, INT1 latency	-	-	4	SYSCCLK

Table 14. Interrupt AC Timing

6.9 JTAG AC Timing

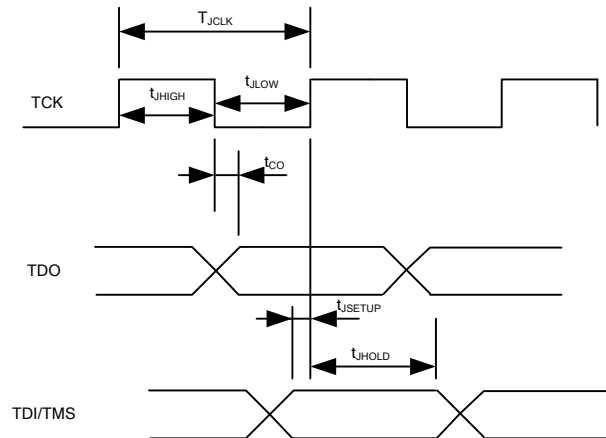

Figure 11 JTAG timing

Unless specified, $T_a = 25^\circ\text{C}$.

Symbol	Parameter	Min	Typ	Max	Unit
T_{JCLK}	TCK Period	-	-	50	MHz
t_{JHIGH}	TCK High Period	10	-	-	nsec
t_{JLOW}	TCK Low Period	10	-	-	nsec
t_{CO}	TCK to TDO propagation delay time	0	-	5	nsec
t_{JSETUP}	TDI/TMS setup time	4	-	-	nsec
t_{JHOLD}	TDI/TMS hold time	0	-	-	nsec

Table 15 JTAG AC Timing

7 I/O Structure

The following figure shows the motor PWM output (PWMUH/PWMUL/PWMVH/PWMVL/PWMWH/PWMWL)

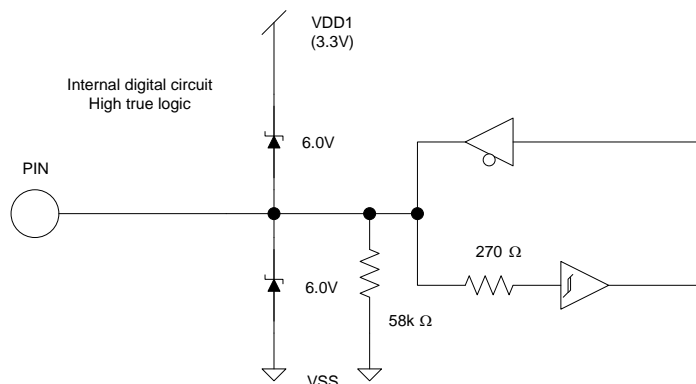

Figure 12 PWMUL/PWMUH/PWMVL/PWMVH/PWMWL/PWMWH output

The following figure shows the digital I/O structure except the motor PWM output

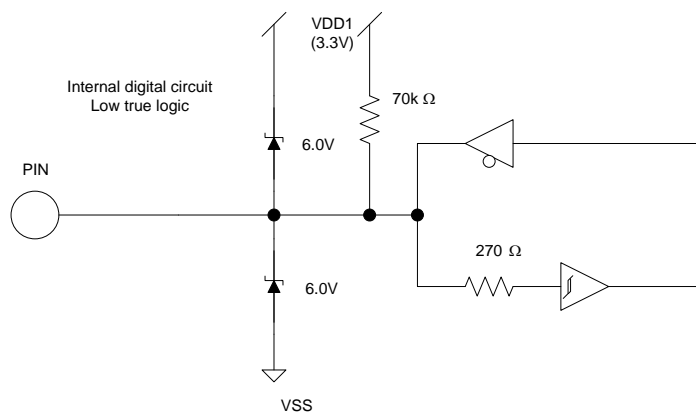

Figure 13 All digital I/O except motor PWM output

The following figure shows RESET and GATEKILL I/O structure.

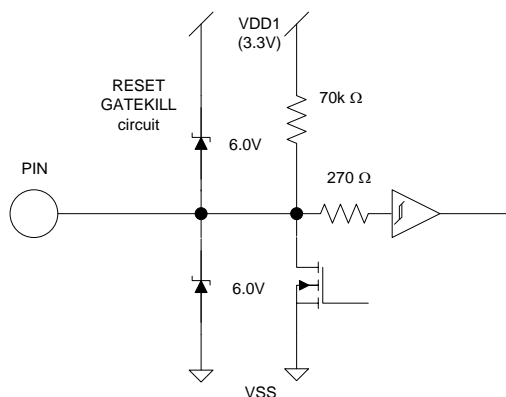

Figure 14 RESET, GATEKILL I/O

The following figure shows the analog input structure.

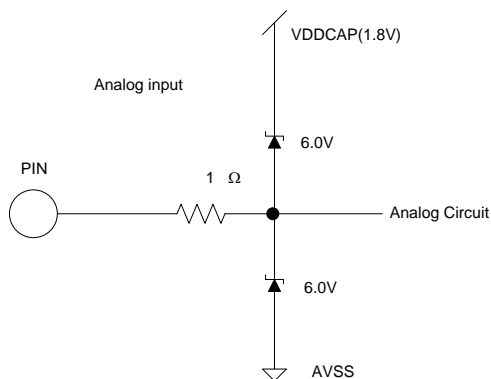

Figure 15 Analog input

The following figure shows all analog operational amplifier output pins and AREF pin I/O structure.

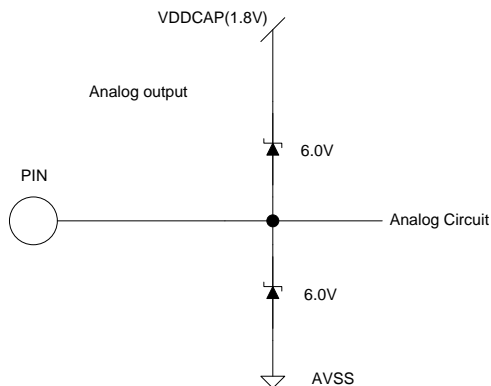

Figure 16 Analog operational amplifier output and AREF I/O structure

The following figure shows the VPP pin structure

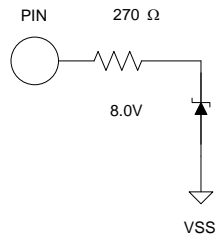

Figure 17 VPP programming pin I/O structure

The following figure shows the VSS and AVSS pins structure

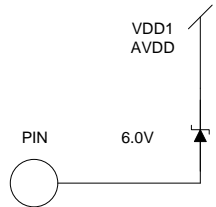

Figure 18 VSS and AVSS pin structure

The following figure shows the VDD1 and VDDCAP pin structure

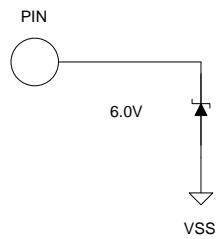

Figure 19 VDD1 and VDDCAP pin structure

The following figure shows the XTAL0 and XTAL1 pins structure

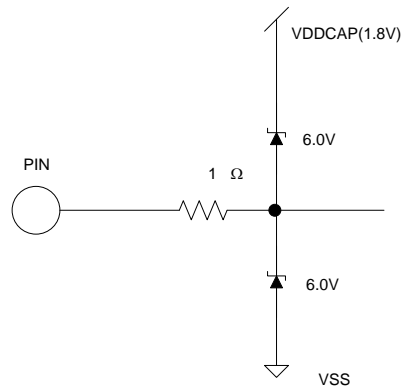

Figure 20 XTAL0/XTAL1 pins structure

8 Pin List

Pin Number	Pin Name	Internal Pull-up /Pull-down	Pin Type	Description
1	P1.1/RXD		I/O	UART receiver input or Discrete programmable I/O
2	P1.2/TXD		I/O	UART transmitter output or Discrete programmable I/O
3	XTAL0		I	Crystal input
4	XTAL1		O	Crystal output
5	VDD1		P	3.3V digital power
6	VSS		P	Digital common
7	VDDCAP		P	Internal 1.8V output, Capacitor(s) to be connected. To be connected to pin 19
8	P3.2/INT0		I/O	Discrete programmable I/O or Interrupt 0 input
9	P2.6/AOPWM0		I/O	Discrete programmable I/O or PWM 0 digital output
10	AIN0		I	Analog input channel 0, 0-1.2V range, needs to be pulled down to AVSS if unused
11	AIN1		I	Analog input channel 1, 0-1.2V range, needs to be pulled down to AVSS if unused
12	IFBU-		I	Single or U-phase leg shunt current sensing OP amp input (-)
13	IFBU+		I	Single or U-phase leg shunt current sensing OP amp input (+)
14	IFBUO		O	Single or U-phase leg shunt current sensing OP amp output
15	IFBV-		I	Single or V-phase leg shunt current sensing OP amp input (-)
16	IFBV+		I	Single or V-phase leg shunt current sensing OP amp input (+)
17	IFBVO		O	Single or V-phase leg shunt current sensing OP amp output
18	AVSS		P	Analog ground
19	AVDD		P	Analog Power 1.8V
20	VDD1		P	3.3V digital power
21	PWMWL	58 k Ω Pull down	O	PWM gate drive for phase W low side, configurable either high or low true.
22	PWMVL	58 k Ω Pull down	O	PWM gate drive for phase V low side, configurable either high or low true
23	PWMUL	58 k Ω Pull down	O	PWM gate drive for phase U low side, configurable either high or low true
24	PWMWH	58 k Ω Pull down	O	PWM gate drive for phase W high side, configurable either high or low true

Pin Number	Pin Name	Internal Pull-up /Pull-down	Pin Type	Description
25	PWMVH	58 kΩ Pull down	O	PWM gate drive for phase V high side, configurable either high or low true
26	PWMUH	58 kΩ Pull down	O	PWM gate drive for phase U high side, configurable either high or low true
27	GATEKILL	70k kΩ Pull up	I	PWM shutdown input
28	TMS/P5.2		I	JTAG test mode select or Discrete Input
29	TDO/P5.3		O	JTAG test data output or Discrete Output
30	TDI/P5.1		I	JTAG test data input or Discrete Input
31	TCK		I	JTAG test clock
32	RESET	70k kΩ Pull up	I/O	Reset, low true, Schmitt trigger input

Table 16 Pin List

9 Package Dimensions

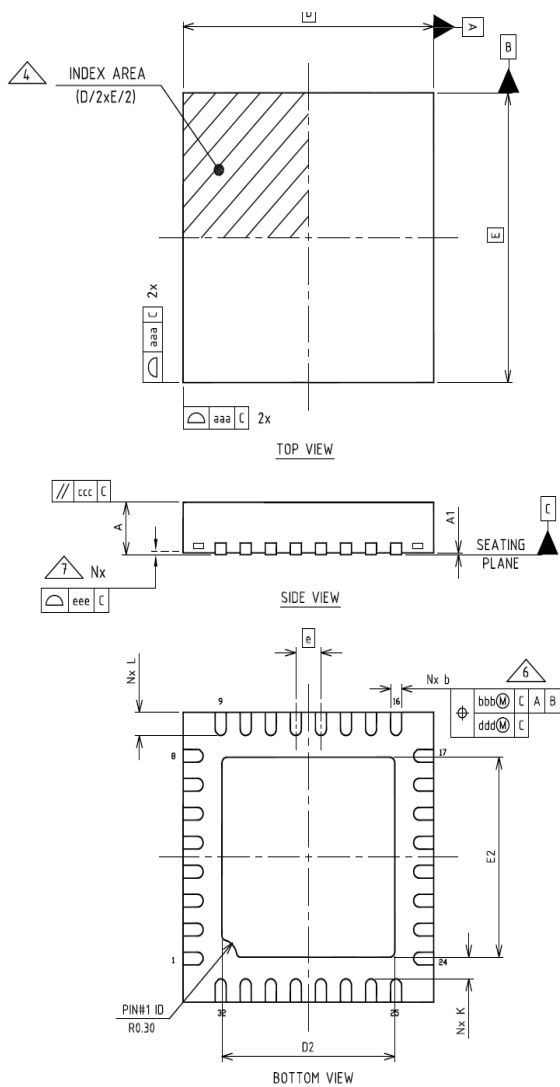

Dimension Table				
Thickness Symbol	W : Very Very Thin			NOTE
	MINIMUM	NOMINAL	MAXIMUM	
A	0.70	0.75	0.80	
A1	0.00	0.02	0.05	
b	0.18	0.25	0.30	6
D	5.00 BSC			
E	5.00 BSC			
e	0.50 BSC			
D2	3.30	3.45	3.55	
E2	3.30	3.45	3.55	
K	0.20	---	---	
L	0.30	0.40	0.50	
aaa	0.05			
bbb	0.10			
ccc	0.10			
ddd	0.05			
eee	0.08			
N	32			3
ND	8			5
NE	8			5
NOTES	1, 2			
LF PART NO.	437727			
LF DWG. NO.	CARSEM-06257			
REV.	A			

NOTE:

1. Dimensioning and tolerancing conform to ASME Y14.5-2009.
2. All dimensions are in millimeters.
3. N is the total number of terminals.
4. The location of the marked terminal #1 identifier is within the hatched area.
5. ND and NE refer to the number of terminals on D and E side respectively .
6. Dimension b applies to the metallized terminal and is measured between 0.15mm and 0.30mm from the terminal tip. If the terminal has a radius on the other end of it, dimension b should not be measured in that radius area.
7. Coplanarity applies to the terminals and all other bottom surface metallization.

10 Part Marking Information

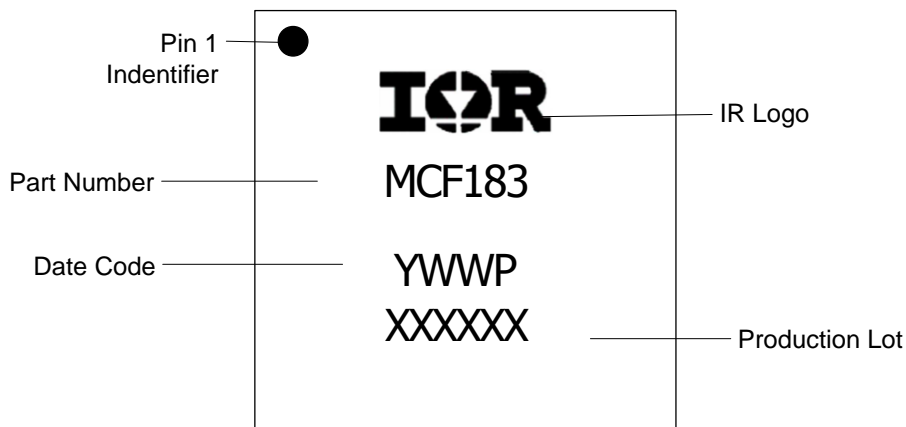

11 Qualification Information

Qualification Level		Industrial ^{††} (per JEDEC JESD47)
Moisture Sensitivity Level		MSL2 ^{†††} (per IPC/JEDEC J-STD-020)
ESD	Machine Model	Class B (per JEDEC standard JESD22-A115)
	Human Body Model	Class 2 (per ANSI/ESDA/JEDEC JS-001)
	Charged Device Model	Class C2 (per JEDEC standard JESD22-C101)
	Latch-Up	Class I, Level B (per JEDEC standard JESD78)
RoHS Compliant		Yes

† Qualification standards can be found at International Rectifier's web site <http://www.irf.com/>

†† Higher qualification ratings may be available should the user have such requirements. Please contact your International Rectifier sales representative for further information.

††† Higher MSL ratings may be available for the specific package types listed here. Please contact your International Rectifier sales representative for further information.

International
 Rectifier

Data and Specifications are subject to change without notice
IR WORLD HEADQUARTERS: 233 Kansas St., El Segundo, California 90245, USA Tel: (310) 252-7105
TAC Fax: (310) 252-7903
Visit us at www.irf.com for sales contact information

Looking for pricing, stock, or lifecycle information?

Click below to explore more details on WIN SOURCE:

 [View IRMCF183M on WIN SOURCE](#)

 [Infineon Technologies](#) Information

Optimize Your Supply Chain with WIN SOURCE Solutions

-  Global Sourcing Solution
-  Obsolete Management
-  Cost Control Management
-  Shortage Management
-  Alternative Solution
-  Excess Inventory Management