



**THE DATASHEET OF  
SLG59M1606V**



## Dual 4.5 A Integrated Power Switch with Reverse Current Blocking

### General Description

The SLG59M1606V is designed for load switching application. The part comes with two 4.5 A rated MOSFETs switched on by two ON control pins. Each MOSFETs turn on time is independently adjusted by an external capacitor.

### Features

- Two 4.5 A independent MOSFETs with Reverse Current Blocking
- Two Integrated VGS Charge Pumps
- Independent Ramp Control
- Protected by thermal shutdown
- Pb-Free / RoHS Compliant
- Halogen-Free
- STDFN 14L, 1 x 3 x 0.55 mm

### Pin Configuration

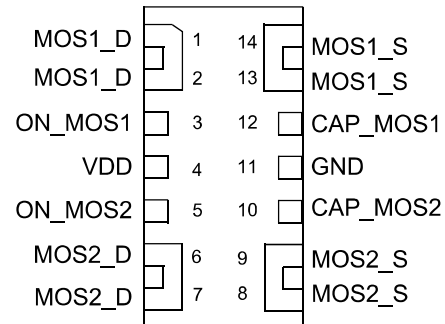

**14-pin STDFN**  
(Top View)

### Applications

- Ideal for switching ON and OFF S0 +5.0 and 3.3V power rails with associated support circuitry
- Ideal for switching ON and OFF power rails 5V or less.
- Can use either channel up to 5.5A with combined maximum current of 8.5A
- Maximum load capacitance of 1000  $\mu$ F for each Channel Source terminal.

### Block Diagram

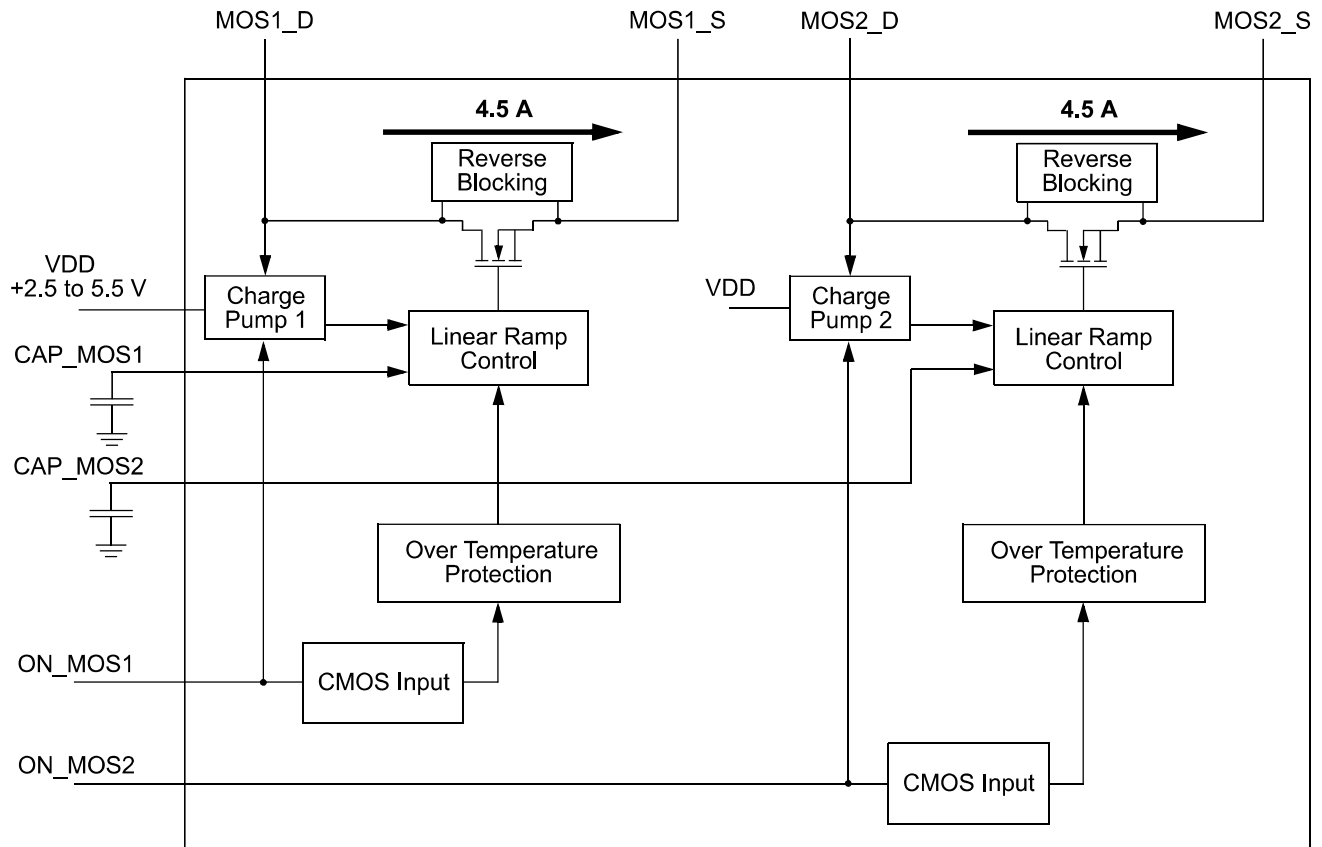



## Pin Description

Pin #	Pin Name	Type	Pin Description
1	MOS1_D	MOSFET	Drain of MOSFET1
2	MOS1_D	MOSFET	Drain of MOSFET1 (fused with pin 1)
3	ON_MOS1	Input	Turns on MOS1 (4 MΩ pull down resistor)
4	VDD	VDD	+5VDD Power
5	ON_MOS2	Input	Turns on MOS2 (4 MΩ pull down resistor)
6	MOS2_D	MOSFET	Drain of MOSFET2
7	MOS2_D	MOSFET	Drain of MOSFET2 (fused with pin 6)
8	MOS2_S	MOSFET	Source of MOSFET2 (fused with pin 9)
9	MOS2_S	MOSFET	Source of MOSFET2
10	CAP_MOS2	Input	Sets ramp and turn on time for MOSFET2
11	GND	GND	Ground
12	CAP_MOS1	Input	Sets ramp and turn on time for MOSFET1
13	MOS1_S	MOSFET	Source of MOSFET1 (fused with pin 14)
14	MOS1_S	MOSFET	Source of MOSFET1

## Ordering Information

Part Number	Type	Production Flow
SLG59M1606V	STDFN 14L	Industrial, -40 °C to 85 °C
SLG59M1606VTR	STDFN 14L (Tape and Reel)	Industrial, -40 °C to 85 °C



## Absolute Maximum Ratings

Parameter	Description	Conditions	Min.	Typ.	Max.	Unit
$V_D$	Power Supply		--	--	6	V
$T_S$	Storage Temperature		-65	--	150	°C
$ESD_{HBM}$	ESD Protection	Human Body Model	2000	--	--	V
$W_{DIS}$	Package Power Dissipation		--	--	1.2	W
$IDS_{MAX}$	Max Operating Current				4.5	A
MOSFET $IDS_{PK}$	Peak Current from Drain to Source	For no more than 10 continuous seconds out of every 100 seconds	--	--	6	A

Note: Stresses greater than those listed under "Absolute Maximum Ratings" may cause permanent damage to the device. This is a stress rating only and functional operation of the device at these or any other conditions above those indicated in the operational sections of this specification is not implied. Exposure to absolute maximum rating conditions for extended periods may affect reliability.

## Electrical Characteristics

$T_A = -40\text{ °C}$  to  $85\text{ °C}$  (unless otherwise stated)

Parameter	Description	Conditions	Min.	Typ.	Max.	Unit
$V_{DD}$	Power Supply Voltage		2.5	--	5.5	V
$I_{DD}$	Power Supply Current when OFF		--	0.1	1	μA
	Power Supply Current ON_MOS_1 & ON_MOS_2 (Steady State)		--	50	100	μA
$RDS_{ON}$	ON Resistance	$T_A\ 25\text{ °C}$ MOSFET1 @100 mA	--	16.0	19.8	mΩ
		$T_A\ 70\text{ °C}$ MOSFET1 @100 mA	--	18.7	24.2	mΩ
		$T_A\ 85\text{ °C}$ MOSFET1 @100 mA		19.8	25.3	mΩ
		$T_A\ 25\text{ °C}$ MOSFET2 @100 mA	--	16.0	19.8	mΩ
		$T_A\ 70\text{ °C}$ MOSFET2 @100 mA	--	18.7	24.2	mΩ
		$T_A\ 85\text{ °C}$ MOSFET2 @100 mA		19.8	25.3	mΩ
MOSFET $IDS$	Current from Drain to Source for each MOSFET	Continuous, each channel	--	--	4.5	A
$IDS_{LKG}$	IDS Leakage (Reverse Blocking enabled)	$V_S = 1.0\text{ V}$ to $5.0\text{ V}$ , $V_{DD} = V_D = 0\text{ V}$ , ON_MOS = LOW, $0$ to $85\text{ °C}$ , each channel	--	0.5	1.5	μA
		$V_S = 1.0\text{ V}$ to $5.0\text{ V}$ , $V_{DD} = V_D = 0\text{ V}$ , ON_MOS = LOW, $-40$ to $0\text{ °C}$ , each channel	--	3	5	μA
$V_D$	Drain Voltage		0.85	5.0	$V_{DD}$	V
$T_{ON\_Delay}$	ON pin Delay Time	50% ON to Ramp Begin, $R_L = 20\ \Omega$ , $C_L = 10\ \mu\text{F}$	0	300	500	μs
$T_{Total\_ON}$	Total Turn On Time	50% ON to 90% $V_S$	Configurable <sup>1</sup>			ms
		Example: CAP = 4 nF, $V_{DD} = V_D = 5\text{ V}$ , Source_Cap = 10 μF, $R_L = 20\ \Omega$	--	2.0	--	ms
$T_{SLEWRATE}$	Slew Rate	10% $V_S$ to 90% $V_S$	Configurable <sup>1</sup>			V/ms
		Example: CAP = 4 nF, $V_{DD} = V_D = 5\text{ V}$ , Source_Cap = 10 μF, $R_L = 20\ \Omega$	--	3.0	--	V/ms
$CAP_{SOURCE}$	Source Cap	Source to GND	--	--	1000	μF
ON_ $V_{IH}$	High Input Voltage on ON pin		0.85	--	$V_{DD}$	V
ON_ $V_{IL}$	Low Input Voltage on ON pin		-0.3	0	0.3	V
$THERM_{ON}^2$	Thermal shutoff turn-on temperature		--	125	--	°C



$T_A = -40\text{ }^\circ\text{C}$  to  $85\text{ }^\circ\text{C}$  (unless otherwise stated)

Parameter	Description	Conditions	Min.	Typ.	Max.	Unit
THERM <sub>OFF</sub>	Thermal shutoff turn-off temperature		--	100	--	°C
THERM <sub>TIME</sub>	Thermal shutoff time		--	--	1	ms
T <sub>OFF_Delay</sub>	OFF Delay Time	50% ON to V <sub>S</sub> Fall, V <sub>DD</sub> = V <sub>D</sub> = 5 V, R <sub>L</sub> = 20 Ω, no C <sub>L</sub>	--	--	15	μs

Notes:

1. Refer to table for configuration details.
2. When device enters thermal shutdown, both channels will turn off.



T<sub>SLEW</sub> vs. CAP

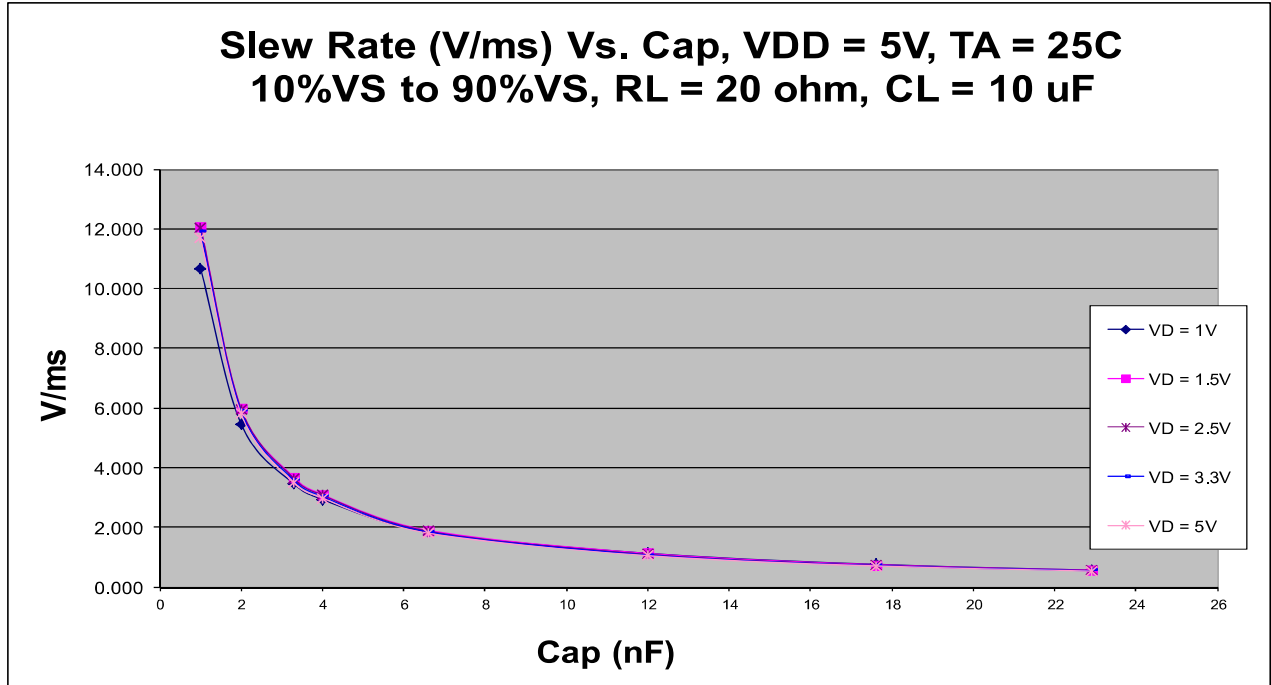

T<sub>TOTAL\_ON</sub> vs. CAP

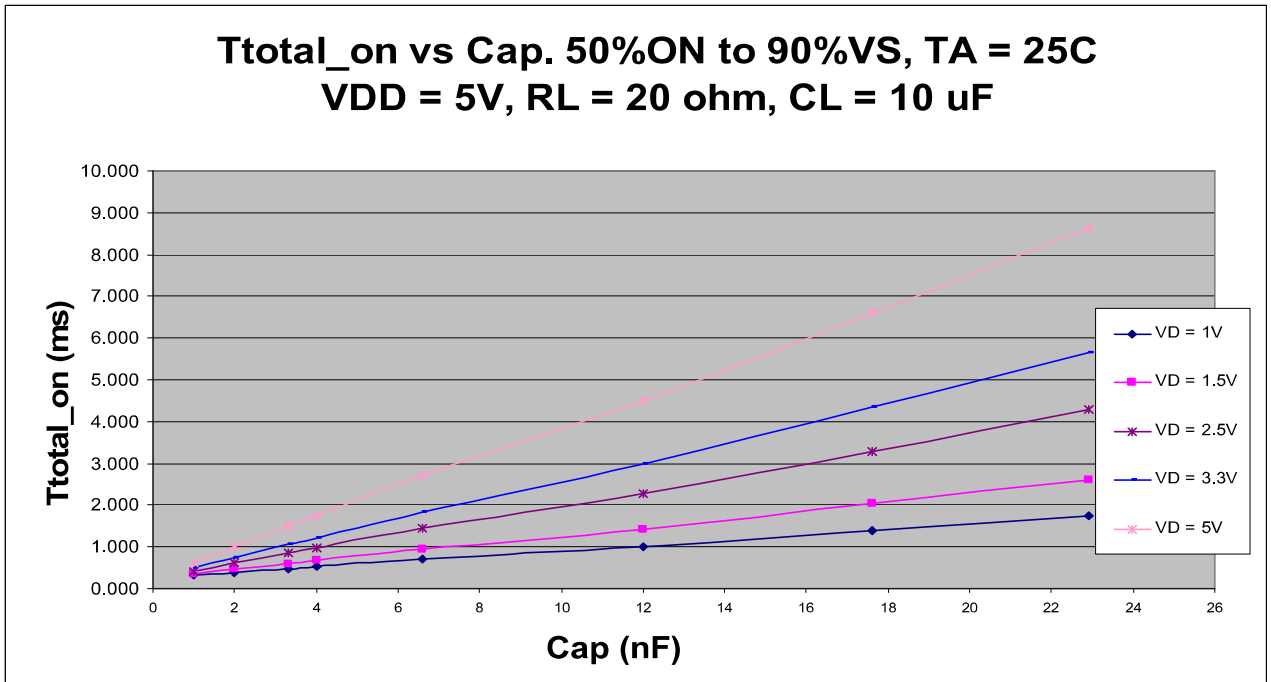



$T_{Total\_ON}$ ,  $T_{ON\_Delay}$  and Slew Rate Measurement

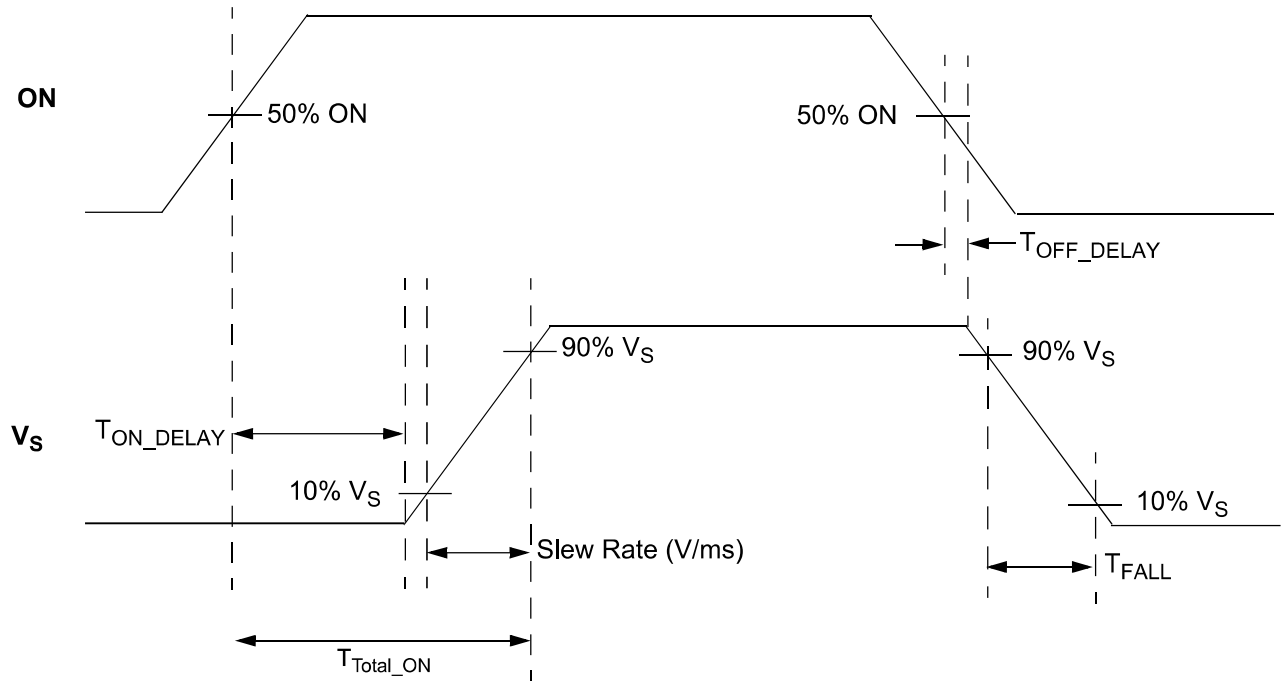



Package Top Marking System Definition

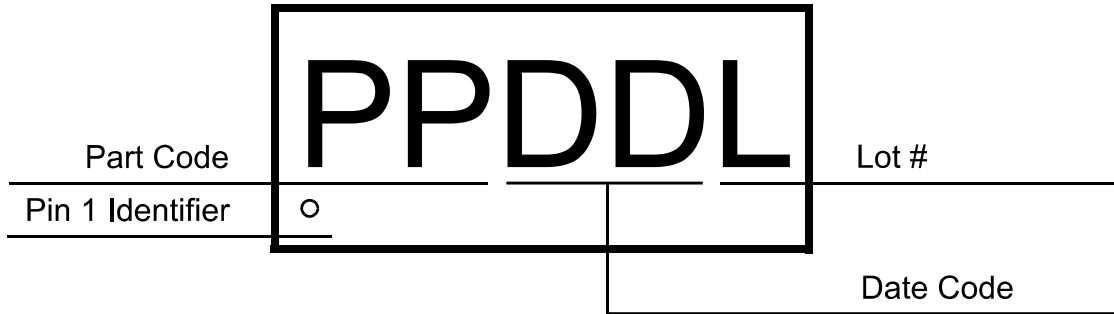



### Package Drawing and Dimensions

14 Lead STDFN Package 1 mm x 3 mm (Fused Lead)

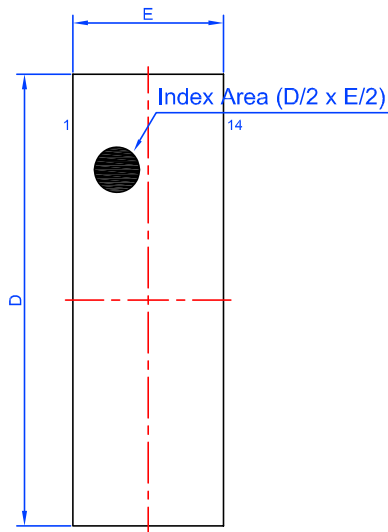

Top View

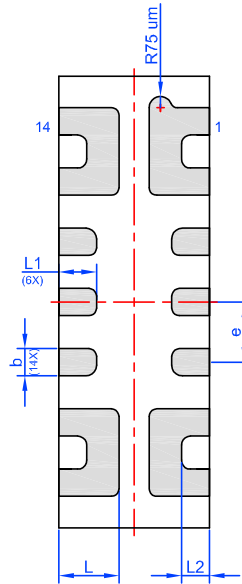

BTM View

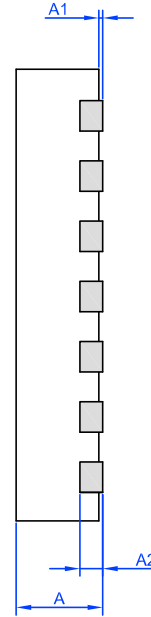

SIDE View

Unit: mm

Symbol	Min	Nom.	Max	Symbol	Min	Nom.	Max
A	0.50	0.55	0.60	D	2.95	3.00	3.05
A1	0.005	-	0.050	E	0.95	1.00	1.05
A2	0.10	0.15	0.20	L	0.35	0.40	0.45
b	0.13	0.18	0.23	L1	0.20	0.25	0.30
e	0.40 BSC			L2	0.06	0.11	0.16



**Tape and Reel Specifications**

Package Type	# of Pins	Nominal Package Size	Units per Reel	Max Units per Box	Reel & Hub Size (mm)	Trailer A		Leader B		Pocket Tape (mm)	
						Pockets	Length (mm)	Pockets	Length (mm)	Width	Pitch
STDFN 14L	14	1x3x0.55mm	3000	3000	178/60	100	400	100	400	8	4

**Carrier Tape Drawing and Dimensions**

Package Type	Pocket BTM Length [mm]	Pocket BTM Width [mm]	Pocket Depth [mm]	Index Hole Pitch [mm]	Pocket Pitch [mm]	Index Hole Diameter [mm]	Index Hole to Tape Edge [mm]	Index Hole to Pocket Center [mm]	Tape Width [mm]
	A0	B0	K0	P0	P1	D0	E	F	W
STDFN 14L	1.15	3.15	0.7	4	4	1.5	1.75	3.5	8

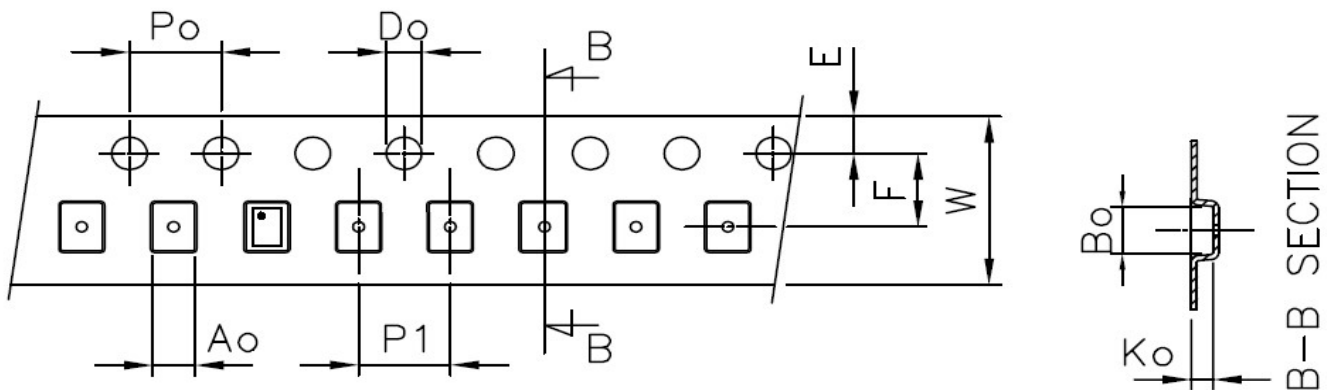

**Recommended Reflow Soldering Profile**

Please see IPC/JEDEC J-STD-020: latest revision for reflow profile based on package volume of 1.65 mm<sup>3</sup> (nominal). More information can be found at [www.jedec.org](http://www.jedec.org).



---

**Revision History**

Date	Version	Change
10/8/2015	1.01	Updated Block Diagram Updated VD min to 0.85 V
9/9/2015	1.00	Production Release Updated Electrical Characteristics conditions

## Looking for pricing, stock, or lifecycle information?

Click below to explore more details on WIN SOURCE:

- ⊖ [View SLG59M1606V on WIN SOURCE](#)
- ⊖ [Dialog Semiconductor GmbH Information](#)

## Optimize Your Supply Chain with WIN SOURCE Solutions

- ✓ Global Sourcing Solution
- ✓ Obsolete Management
- ✓ Cost Control Management
- ✓ Shortage Management
- ✓ Alternative Solution
- ✓ Excess Inventory Management