



THE DATASHEET OF STCC08RL



AC switch failure mode detector

Features

- 3.3 V and 5 V power supply compatible
- ACS, ACST, TRIAC compatible
- Gate driver output: 28 mA max sink current
- Adjustable gate drive current
- Sense the AC switch voltage in both AC line polarities
- Diode mode failure detection for solid state AC switches
- Short circuit failure detection for AC switches, relays, electromechanical switches
- Open AC switch detection for AC switches, relays, electromechanical switches
- SO-8 SMD package

Benefits

- Enable appliances to meet IEC 60335-1 and IEC 60730-1 standards
- Enable appliances to meet IEC 61000-4-4 standard
- Eliminates high DC current in inductive load, by detecting the diode mode failure
- Improve system safety monitoring open switch failure with critical loads such as door locks
- Enable MCU to sense all AC switch failure modes and protect the appliance
- Less MCU pin allocated to AC failure detection multiple STCC08 designed with resistor dividers uses one I/O
- Easy to drive with MCU directly connected or through an opto coupler
- Highly compact with integrated solution in SMD version

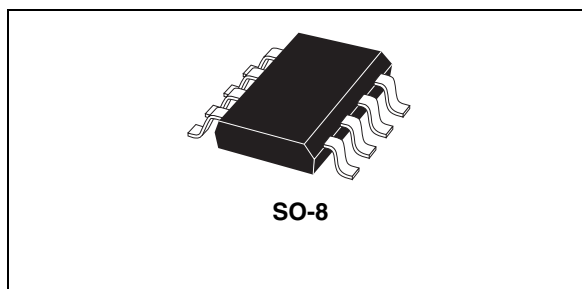

Applications

- Home appliances
- ACS, ACST, TRIAC drive
- AC switch failure modes detection
- Zero voltage synchronization

Description

The STCC08 is an AC switch failure mode detector and an AC power switch driver. It drives the AC switch and informs the MCU of switch failure. The MCU takes the appropriate actions to put the system in a secure state.

Diode-mode, short circuit detection and open switch in both AC line polarities are detected.

The STCC08 helps home appliances to meet the IEC 60335-1 safety standard.

The STCC08 can be easily interfaced to an MCU with its CMOS input AC switch driver and CMOS compatible output for the failure mode detector.

1 Characteristics

Figure 1. Circuit block diagram

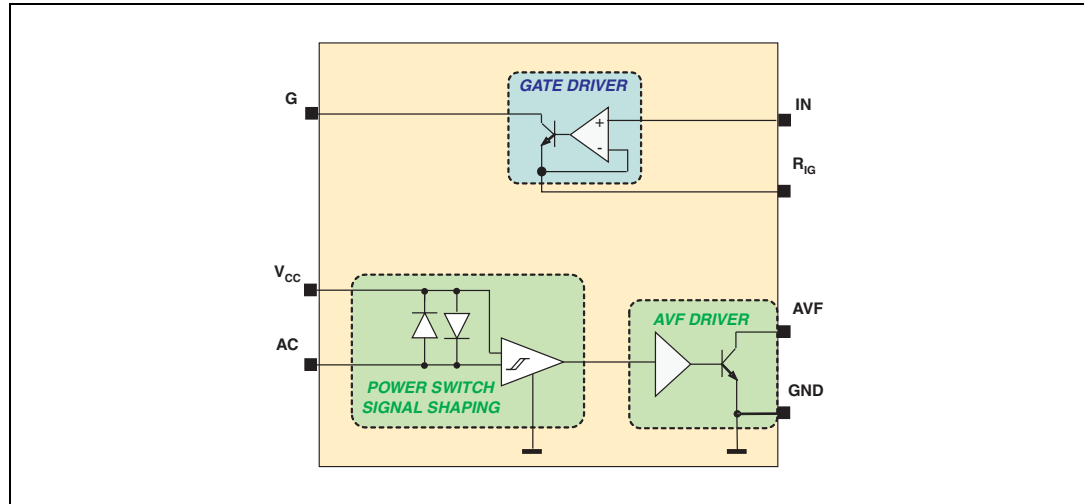

Table 1. Circuit pin descriptions

Symbol	Type	Description
IN	SIGNAL	Logic AC switch drive
AVF	SIGNAL	Alternating voltage feedback: AC switch status output
AC	SIGNAL	AC switch status sense input
V _{CC}	POWER	Positive power supply
G	SIGNAL	AC switch gate driver output
R _{IG}	SIGNAL	AC switch gate current setting
GND	POWER	Power supply reference

Figure 2. Pin layout (top view)

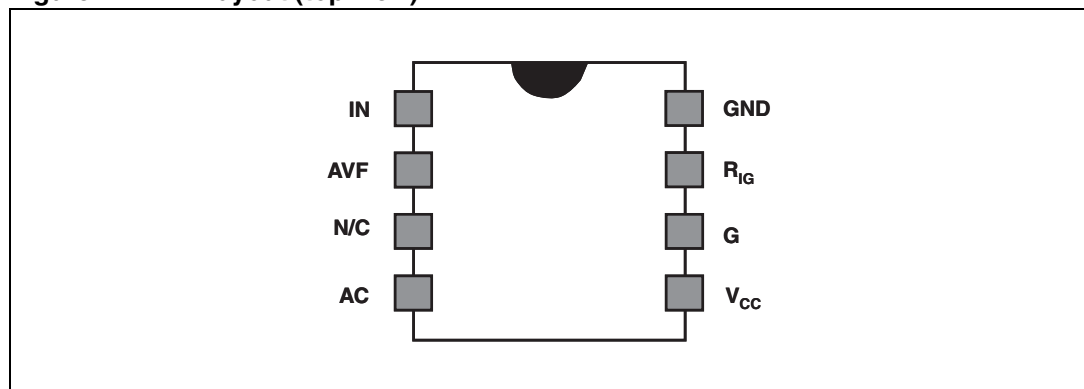

Table 2. Pin allocations

Pin #	Name	Description
1	IN	Logic AC switch drive
2	AVF	Alternating voltage feedback: AC switch status output
3	N/C	Not connected
4	AC	AC switch status sense input
5	V _{CC}	Positive power supply
6	G	AC switch gate driver output
7	R _{IG}	AC switch gate current setting
8	GND	Power supply reference

Table 3. Absolute ratings (T_{amb} = 25 °C unless otherwise stated, respect to GND)

Symbol	Pin	Parameter name and conditions	Value	Unit
V _{CC}	V _{CC}	Power supply voltage	0 to 6	V
V _{IN}	IN	Switch activation voltage	-0.3V to V _{CC} +0.3	V
I _G	G	Sunk driver current	30	mA
I _{AC}	AC	Input sense current peak	2.2	mA
V _{AVF}	AVF	Alternative feedback voltage	-0.3 to V _{CC} +0.3	V
I _{AVF}	AVF	Maximum feedback current	5	mA
T _J	All	Junction temperature range	-20 to 125	°C
		Storage junction temperature range	-40 to 150	°C

Table 4. Recommended operating conditions

Symbol	Pin	Parameter name and conditions	Value	Unit
V _{CC}	V _{CC}	Power supply voltage respect to GND	2.97 to 5.5	V
I _G	G	Max. sunk driver gate current	28	mA
R _{IG}	RIG	Gate current setting resistor	30	Ω
R _{AC}	AC	Detector resistance for AC line = 120 V	100	kΩ
		Detector resistance for AC line = 230 V	300	kΩ
R _{SHUNT}	-	HV biasing resistance for AC line = 120 V	100	kΩ
		HV biasing resistance for AC line = 230 V	300	kΩ
T _{AMB}	All	Operating ambient temperature range	-20 to 85	°C
T _J	All	Operating junction temperature range	-20 to 125	°C

Table 5. Electrical characteristics

Symbol	Pin	Name	Conditions	Min	Typ	Max	Unit
Switch drive (respect to GND, $T_j=25\text{ °C}$ unless otherwise specified, $R_{IG}=30\ \Omega$)							
$I_{\text{QUIESCENT}}$	V_{CC}	Quiescent current	$I_{\text{IN}} = \text{GND}$			2	mA
V_{ON}	IN	On-state switch activation voltage		$0.7 \cdot V_{\text{CC}}$			V
V_{OFF}	IN	Off-state switch release voltage				$0.3 \cdot V_{\text{CC}}$	V
I_{IN}	IN	Input drive current	$V_{\text{in}} > V_{\text{on}}$			50	μA
I_{G}	G	Gate drive current	$V_{\text{in}} > V_{\text{on}}$	20		28	mA
I_{AC}	AC	Detection threshold		82		236	μA
Status output (respect to GND, $T_j=25\text{ °C}$ unless otherwise specified)							
V_{OH}	AVF	Minimum output voltage	$I_{\text{AVF}} = 50\ \mu\text{A}$	$0.7 \cdot V_{\text{CC}}$			V
V_{OL}	AVF	Maximum drop voltage	$I_{\text{AVF}} = 50\ \mu\text{A}$ (CMOS Compatible)			$0.3 \cdot V_{\text{CC}}$	V
			$I_{\text{AVF}} = 5\ \text{mA}$ (Opto-transistor compatible)			1	V

Table 6. Thermal resistance

Symbol	Parameter name and conditions	Value	Unit
$R_{\text{TH (j-a)}}$	SMD Thermal resistance Junction to Ambient	140	$^{\circ}\text{C/W}$

Table 7. System related electromagnetic compatibility ratings

Symbol	Node	Pin	Parameter name and conditions	Value	Unit
V_{ESD}	Neutral	V_{CC}	ESD protection, IEC 61000-4-2, per input, against air discharge	± 8	kV
		G	Gate through ACS; ESD protection, IEC 61000-4-2, pin to ground, against air discharge		
	Line	AC	Alternating current through $R_{\text{AC}} = 300\ \text{k}\Omega$; ESD protection, IEC 61000-4-2, pin to ground, against air discharge		
V_{ESD}	Neutral	V_{CC}	ESD protection, IEC 61000-4-2, pin to ground, for contact discharge ⁽¹⁾	± 6	kV
V_{PPB}	Neutral	V_{CC}	Total Peak Pulse Voltage Burst, IEC 61000-4-4 ⁽¹⁾	± 4	kV
		G	Gate through ACS; Total Peak Pulse Voltage Burst, IEC 61000-4-4 ⁽¹⁾		
	Line	AC	Alternating current through R_{AC} ; Total Peak Pulse Voltage Burst, IEC 61000-4-4 ⁽¹⁾		

1. System oriented test circuits - see Application note AN2716

2 Functional description

STCC08 functional description

The STCC08 is a power circuit designed to drive up to 10 mA I_{GT} AC switches and to detect AC switch failure modes through MCU diagnostic.

It embeds a logic switch driver, an AC switch diode mode detection, a short circuit detection and an AC switch open detection.

STCC08 can be powered by a 3.3 V or 5 V power supply voltage.

Switch driver

This driver is a logic level buffer (CMOS compatible) interfacing directly with the AC switch and the microcontroller.

The AC switch must be driven in negative polarity: AC switch COM = $A_1 = V_{CC}$

The drive Boolean rule is:

$V_{in} > V_{on}$: switch = ON

$V_{in} < V_{on}$: switch = OFF

The AC switch can be driven in continuous, pulsed or angle phase modes.

In insulated applications, the input can be driven through an opto-coupler powered with a non-insulated auxiliary power supply.

R_{IG} pin allows the AC switch gate current to be set. A resistor must be connected between this pin and the ground GND. This resistor is defined according to the minimum ambient temperature and the AC switch I_{GT} (see [Figure 3](#)). This optimizes the consumption of the application.

Figure 3. $R_{ig} = f(T_{amb_min})$ for 5/10 mA AC switches

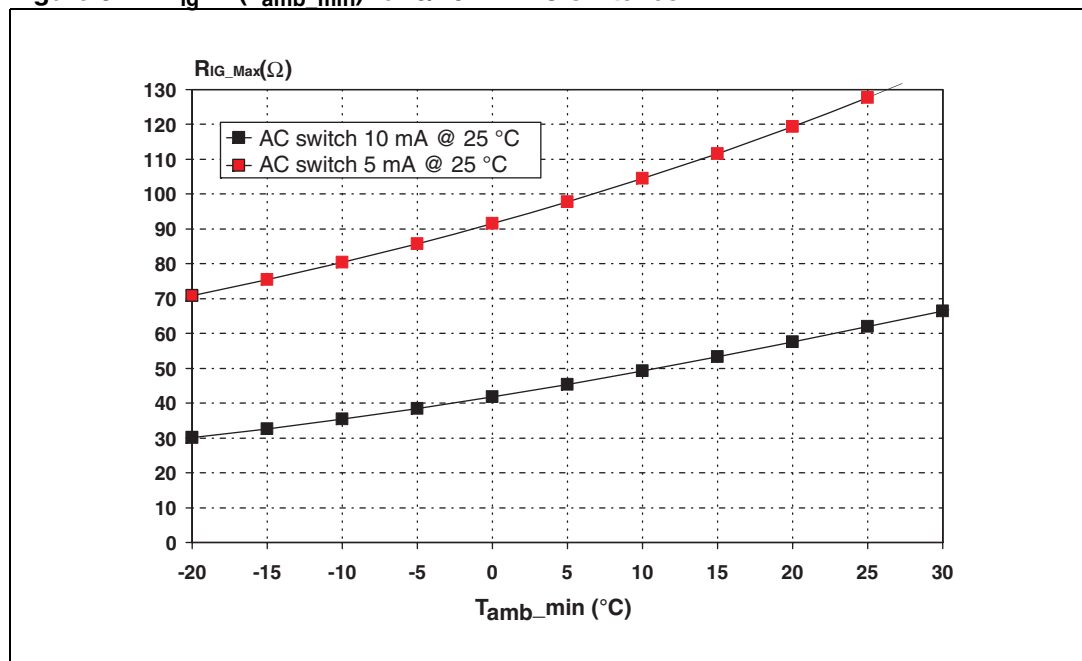

Failure mode detection

This function detects AC switch failure modes required by the IEC 60335 standard:

- The AC switch diode mode failure in both negative and positive AC line polarities
This failure is simulated with a diode placed in parallel with the power switch according to the IEC 60335-1 standard.
- The AC switch short-circuit failure mode, any external shorting and any spurious power switch turn-on
- The open AC switch failure mode

This function improves the system safety. A diode mode failure, a short circuit or an AC switch open can lead to dangerous situations for the system or the user.

The AVF block monitors the state of the AC switch in both AC polarities. Its output AVF is transmitted to the MCU for failure detection.

The MCU detects the failure according to the following truth table:

Table 8. STCC08 status truth table with R_{SHUNT} in parallel with the load

IN (MCU generated)	AVF	MCU DIAGNOSTIC
0	Open collector	AC switch OK
0	Open collector to 0 toggle	Diode mode
0	0	Short AC switch
1	0	AC switch OK
1	Open collector	Open AC switch

For a diode mode, the AVF output toggles from open collector to GND each the half of the AC mains. Therefore, the AVF output is a pulsed signal during a diode mode failure.

The MCU can put the system in a safe configuration, switching off the front end relay already existing in home appliance designs.

Status reading

The AVF output is an open collector, active at low level. It can either be connected to a MCU input, in pull up input configuration, or through an opto-coupler in insulated designs.

For inductive loads, there is a phase shift between load current and AC line voltage. When the ACS control is removed:

- The AC switch - latch structure - still conducts and the AVF is at low level until the next zero current crossing.
- The AVF is at low level until next zero current crossing.
- In the worst case, the load current crosses zero close to peak mains voltage. Then the AVF signal should be read at peak mains voltage.

Figure 4. Failure mode detection for inductive loads in DC control mode

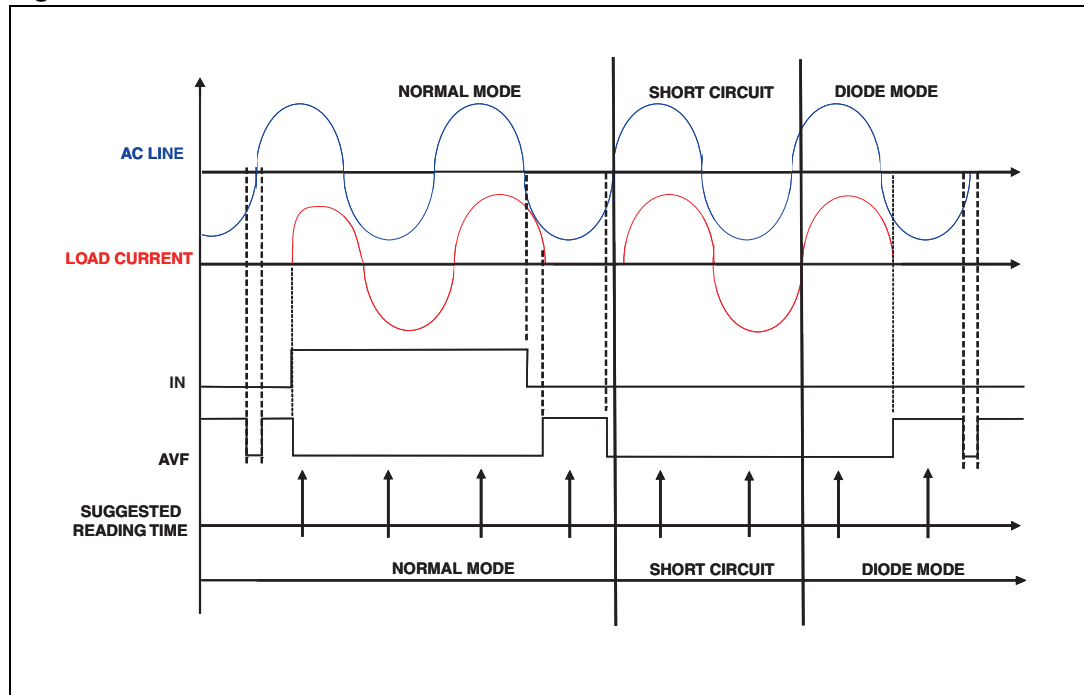

The microcontroller can store the AC switch drive signal in a RAM register when it is driving the STCC08 input. Therefore it can save gate energy while determining conduction state from this RAM register and multiplexing this information with AVF signal.

AC LINE: High voltage between AC line and neutral

LOAD CURRENT: Current through the AC load

IN: MCU output driving the STCC08 IN input.

AVF: Alternating voltage feedback, output of the STCC08

This function is effective whatever the drive and the nature of the load.

Figure 7. ACS benefits

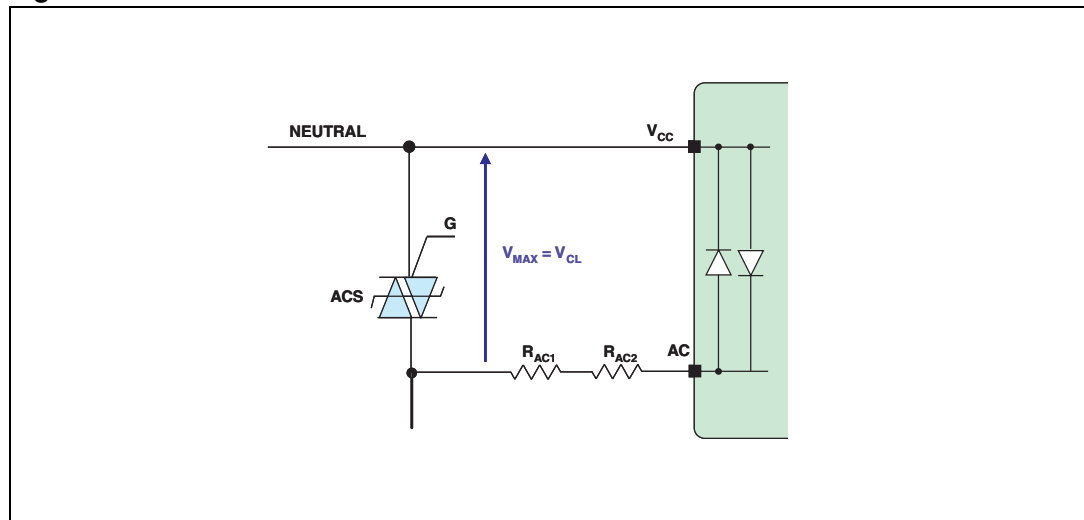

The ACS clamping capability, from 800 V to 1100 V reduces the stress across R_{AC} resistors during an AC line over-voltage. This provides a robust solution and allows setting high voltage resistors R_{AC} to withstand the ACS clamping voltage instead of the AC line maximum over-voltage.

STCC08 AVF alarms configuration

Figure 8. Open load and Short circuit ACS discrimination

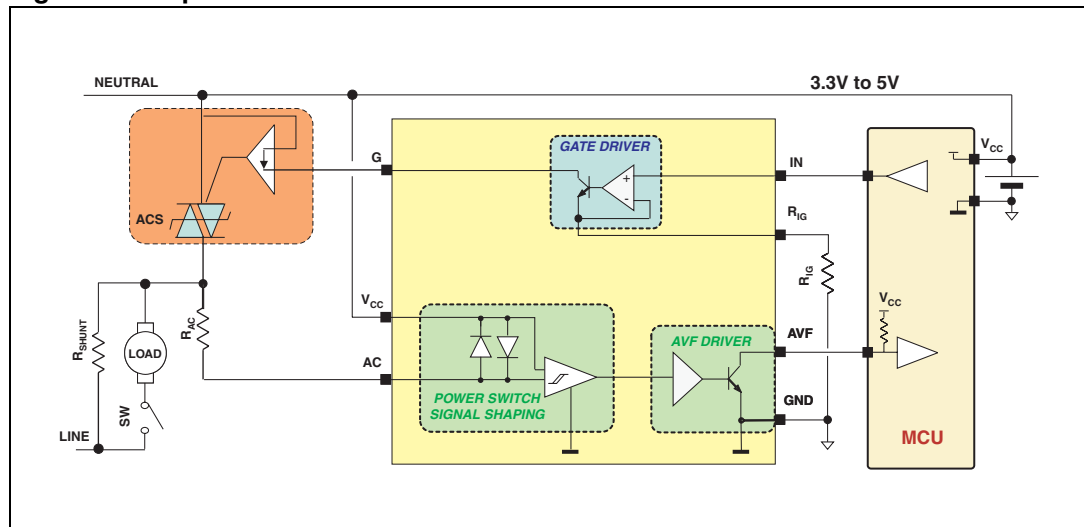

When R_{SHUNT} is removed, the MCU cannot discriminate between an ACS short circuit and open load failure. See [Table 9](#).

Table 9. STCC08 status truth table with R_{SHUNT} removed

IN (MCU generated)	AVF	MCU DIAGNOSTIC
0	Open collector	AC switch OK
0	Open collector to 0 toggle	Diode mode
0	0	Short circuit or open lead
1	0	AC switch OK
1	Open collector	Open AC switch

STCC08 ZVS application

Figure 9. ZVS application schematic

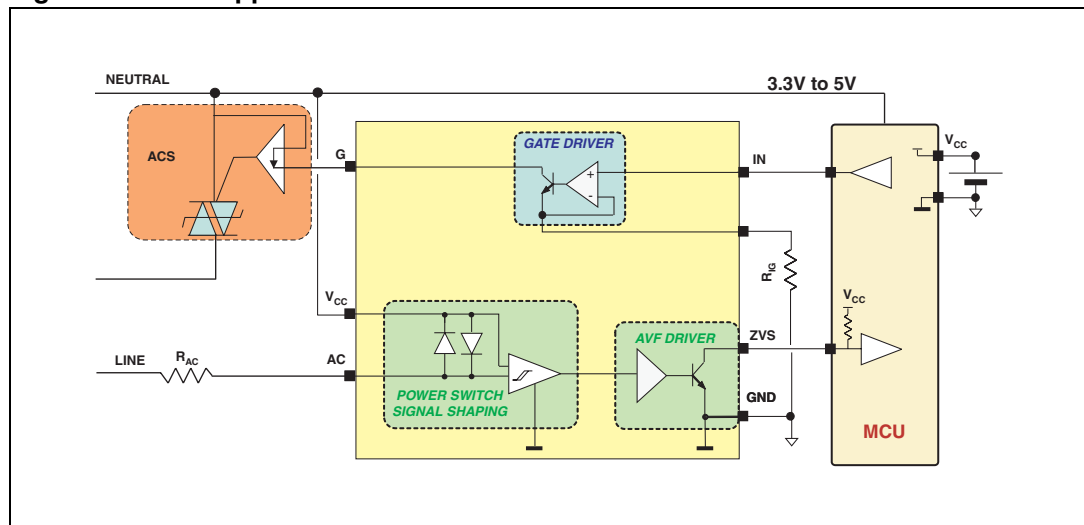

The gate driver drives an ACS while the failure detector is used independently for ZVS detection

4 Package information

- Epoxy meets UL94, V0

In order to meet environmental requirements, ST offers these devices in ECOPACK® packages. These packages have a lead-free second level interconnect. The category of second level interconnect is marked on the inner box label, in compliance with JEDEC Standard JESD97. The maximum ratings related to soldering conditions are also marked on the inner box label. ECOPACK is an ST trademark. ECOPACK specifications are available at www.st.com.

Table 10. SO-8 dimensions

Ref.	Dimensions					
	Millimeters			Inches		
	Min.	Typ.	Max.	Min.	Typ.	Max.
A			1.75			0.069
A1	0.1		0.25	0.004		0.010
A2	1.25			0.049		
b	0.28		0.48	0.011		0.019
C	0.17		0.23	0.007		0.009
D	4.80	4.90	5.00	0.189	0.193	0.197
E	5.80	6.00	6.20	0.228	0.236	0.244
E1	3.80	3.90	4.00	0.150	0.154	0.157
e		1.27			0.050	
h	0.25		0.50	0.010		0.020
L	0.40		1.27	0.016		0.050
L1		1.04			0.041	
k	0°		8°	0°		8°
ppp			0.10			0.004

Figure 10. Footprint dimensions in mm(inches)

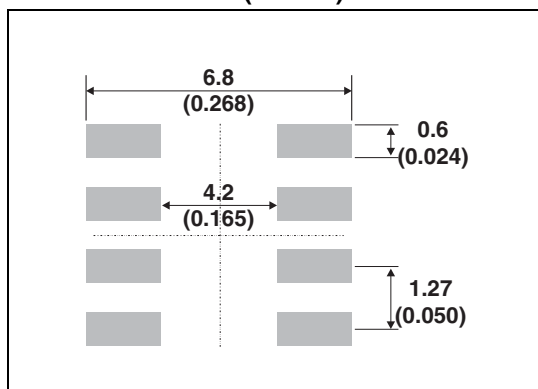
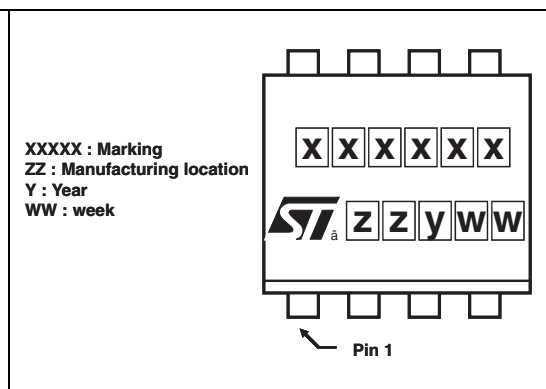

Figure 11. Marking



5 Ordering information

Table 11. Ordering information

Order code	Marking	Weight	Base Qty	Delivery Mode
STCC08	STCC08	0.08 g	100	Tube
STCC08RL	STCC08	0.08 g	2500	Tape and reel 13"

6 Revision history

Table 12. Document revision history

Date	Revision	Changes
20-Mar-2008	1	Initial release.

Please Read Carefully:

Information in this document is provided solely in connection with ST products. STMicroelectronics NV and its subsidiaries ("ST") reserve the right to make changes, corrections, modifications or improvements, to this document, and the products and services described herein at any time, without notice.

All ST products are sold pursuant to ST's terms and conditions of sale.

Purchasers are solely responsible for the choice, selection and use of the ST products and services described herein, and ST assumes no liability whatsoever relating to the choice, selection or use of the ST products and services described herein.

No license, express or implied, by estoppel or otherwise, to any intellectual property rights is granted under this document. If any part of this document refers to any third party products or services it shall not be deemed a license grant by ST for the use of such third party products or services, or any intellectual property contained therein or considered as a warranty covering the use in any manner whatsoever of such third party products or services or any intellectual property contained therein.

UNLESS OTHERWISE SET FORTH IN ST'S TERMS AND CONDITIONS OF SALE ST DISCLAIMS ANY EXPRESS OR IMPLIED WARRANTY WITH RESPECT TO THE USE AND/OR SALE OF ST PRODUCTS INCLUDING WITHOUT LIMITATION IMPLIED WARRANTIES OF MERCHANTABILITY, FITNESS FOR A PARTICULAR PURPOSE (AND THEIR EQUIVALENTS UNDER THE LAWS OF ANY JURISDICTION), OR INFRINGEMENT OF ANY PATENT, COPYRIGHT OR OTHER INTELLECTUAL PROPERTY RIGHT.

UNLESS EXPRESSLY APPROVED IN WRITING BY AN AUTHORIZED ST REPRESENTATIVE, ST PRODUCTS ARE NOT RECOMMENDED, AUTHORIZED OR WARRANTED FOR USE IN MILITARY, AIR CRAFT, SPACE, LIFE SAVING, OR LIFE SUSTAINING APPLICATIONS, NOR IN PRODUCTS OR SYSTEMS WHERE FAILURE OR MALFUNCTION MAY RESULT IN PERSONAL INJURY, DEATH, OR SEVERE PROPERTY OR ENVIRONMENTAL DAMAGE. ST PRODUCTS WHICH ARE NOT SPECIFIED AS "AUTOMOTIVE GRADE" MAY ONLY BE USED IN AUTOMOTIVE APPLICATIONS AT USER'S OWN RISK.

Resale of ST products with provisions different from the statements and/or technical features set forth in this document shall immediately void any warranty granted by ST for the ST product or service described herein and shall not create or extend in any manner whatsoever, any liability of ST.

ST and the ST logo are trademarks or registered trademarks of ST in various countries.

Information in this document supersedes and replaces all information previously supplied.

The ST logo is a registered trademark of STMicroelectronics. All other names are the property of their respective owners.

© 2008 STMicroelectronics - All rights reserved

STMicroelectronics group of companies



Australia - Belgium - Brazil - Canada - China - Czech Republic - Finland - France - Germany - Hong Kong - India - Israel - Italy - Japan - Malaysia - Malta - Morocco - Singapore - Spain - Sweden - Switzerland - United Kingdom - United States of America

www.st.com



Looking for pricing, stock, or lifecycle information?

Click below to explore more details on WIN SOURCE:

-  [View STCC08RL on WIN SOURCE](#)
-  [STMicroelectronics Information](#)

Optimize Your Supply Chain with WIN SOURCE Solutions

-  Global Sourcing Solution
-  Obsolete Management
-  Cost Control Management
-  Shortage Management
-  Alternative Solution
-  Excess Inventory Management