



**THE DATASHEET OF
CY7C185-35VC**



8K x 8 Static RAM

Features

- **High speed**
— 15 ns
- **Fast t_{DOE}**
- **Low active power**
— 715 mW
- **Low standby power**
— 220 mW
- **CMOS for optimum speed/power**
- **Easy memory expansion with \overline{CE}_1 , CE_2 , and \overline{OE} features**
- **TTL-compatible inputs and outputs**
- **Automatic power-down when deselected**

Functional Description^[1]

The CY7C185 is a high-performance CMOS static RAM organized as 8192 words by 8 bits. Easy memory expansion is

provided by an active LOW chip enable (\overline{CE}_1), an active HIGH chip enable (CE_2), and active LOW output enable (\overline{OE}) and three-state drivers. This device has an automatic power-down feature (\overline{CE}_1 or CE_2), reducing the power consumption by 70% when deselected. The CY7C185 is in a standard 300-mil-wide DIP, SOJ, or SOIC package.

An active LOW write enable signal (\overline{WE}) controls the writing/reading operation of the memory. When CE_1 and WE inputs are both LOW and CE_2 is HIGH, data on the eight data input/output pins (I/O_0 through I/O_7) is written into the memory location addressed by the address present on the address pins (A_0 through A_{12}). Reading the device is accomplished by selecting the device and enabling the outputs, \overline{CE}_1 and \overline{OE} active LOW, CE_2 active HIGH, while WE remains inactive or HIGH. Under these conditions, the contents of the location addressed by the information on address pins are present on the eight data input/output pins.

The input/output pins remain in a high-impedance state unless the chip is selected, outputs are enabled, and write enable (\overline{WE}) is HIGH. A die coat is used to insure alpha immunity.

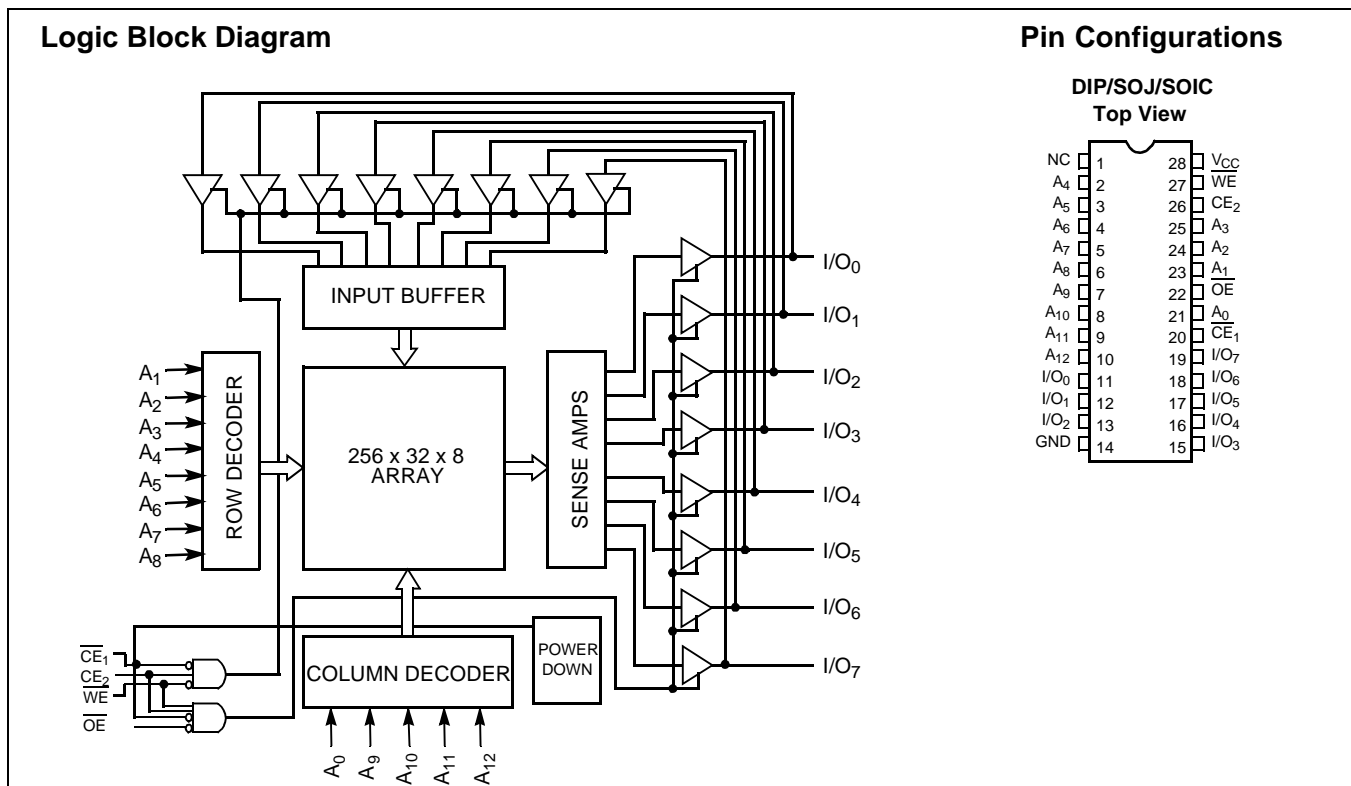

Selection Guide^[2]

	7C185-15	7C185-20	7C185-25	7C185-35
Maximum Access Time (ns)	15	20	25	35
Maximum Operating Current (mA)	130	110	100	100
Maximum Standby Current (mA)	40/15	20/15	20/15	20/15

Note:

1. For guidelines on SRAM system design, please refer to the 'System Design Guidelines' Cypress application note, available on the internet at www.cypress.com.
2. For military specifications, see the CY7C185A data sheet.

Maximum Ratings

(Above which the useful life may be impaired. For user guidelines, not tested.)

Storage Temperature -65°C to +150°C
 Ambient Temperature with
 Power Applied..... -55°C to +125°C
 Supply Voltage to Ground Potential -0.5V to +7.0V
 DC Voltage Applied to Outputs
 in High Z State^[3] -0.5V to +7.0V
 DC Input Voltage^[3]..... -0.5V to +7.0V

Output Current into Outputs (LOW)..... 20 mA
 Static Discharge Voltage..... >2001V
 (per MIL-STD-883, Method 3015)
 Latch-Up Current..... >200 mA

Operating Range

Range	Ambient Temperature	V _{CC}
Commercial	0°C to +70°C	5V ± 10%
Industrial	-40°C to +85°C	5V ± 10%

Electrical Characteristics Over the Operating Range

Parameter	Description	Test Conditions	7C185-15		7C185-20		Unit
			Min.	Max.	Min.	Max.	
V _{OH}	Output HIGH Voltage	V _{CC} = Min., I _{OH} = -4.0 mA	2.4		2.4		V
V _{OL}	Output LOW Voltage	V _{CC} = Min., I _{OL} = 8.0 mA		0.4		0.4	V
V _{IH}	Input HIGH Voltage		2.2	V _{CC} + 0.3V	2.2	V _{CC} + 0.3V	V
V _{IL}	Input LOW Voltage ^[3]		-0.5	0.8	-0.5	0.8	V
I _{IX}	Input Load Current	GND ≤ V _I ≤ V _{CC}	-5	+5	-5	+5	μA
I _{OZ}	Output Leakage Current	GND ≤ V _I ≤ V _{CC} , Output Disabled	-5	+5	-5	+5	μA
I _{OS}	Output Short Circuit Current ^[4]	V _{CC} = Max., V _{OUT} = GND		-300		-300	mA
I _{CC}	V _{CC} Operating Supply Current	V _{CC} = Max., I _{OUT} = 0 mA		130		110	mA
I _{SB1}	Automatic Power-Down Current	Max. V _{CC} , $\overline{CE}_1 \geq V_{IH}$ or CE ₂ ≤ V _{IL} Min. Duty Cycle = 100%	40		20		mA
I _{SB2}	Automatic Power-Down Current	Max. V _{CC} , $\overline{CE}_1 \geq V_{CC} - 0.3V$, or CE ₂ ≤ 0.3V V _{IN} ≥ V _{CC} - 0.3V or V _{IN} ≤ 0.3V	15		15		mA

Notes:

3. Minimum voltage is equal to -3.0V for pulse durations less than 30 ns.
4. Not more than 1 output should be shorted at one time. Duration of the short circuit should not exceed 30 seconds.

Electrical Characteristics Over the Operating Range (continued)

Parameter	Description	Test Conditions	7C185-25		7C185-35		Unit
			Min.	Max.	Min.	Max.	
V _{OH}	Output HIGH Voltage	V _{CC} = Min., I _{OH} = -4.0 mA	2.4		2.4		V
V _{OL}	Output LOW Voltage	V _{CC} = Min., I _{OL} = 8.0 mA		0.4		0.4	V
V _{IH}	Input HIGH Voltage		2.2	V _{CC} + 0.3V	2.2	V _{CC} + 0.3V	V
V _{IL}	Input LOW Voltage ^[3]		-0.5	0.8	-0.5	0.8	V
I _{IX}	Input Load Current	GND ≤ V _I ≤ V _{CC}	-5	+5	-5	+5	μA
I _{oZ}	Output Leakage Current	GND ≤ V _I ≤ V _{CC} , Output Disabled	-5	+5	-5	+5	μA
I _{OS}	Output Short Circuit Current ^[4]	V _{CC} = Max., V _{OUT} = GND		-300		-300	mA
I _{CC}	V _{CC} Operating Supply Current	V _{CC} = Max., I _{OUT} = 0 mA		100		100	mA
I _{SB1}	Automatic Power-Down Current	Max. V _{CC} , $\overline{CE}_1 \geq V_{IH}$ or $CE_2 \leq V_{IL}$ Min. Duty Cycle = 100%		20		20	mA
I _{SB2}	Automatic Power-Down Current	Max. V _{CC} , $\overline{CE}_1 \geq V_{CC} - 0.3V$ or $CE_2 \leq 0.3V$ V _{IN} ≥ V _{CC} - 0.3V or V _{IN} ≤ 0.3V		15		15	mA

Capacitance^[5]

Parameter	Description	Test Conditions	Max.	Unit
C _{IN}	Input Capacitance	T _A = 25°C, f = 1 MHz, V _{CC} = 5.0V	7	pF
C _{OUT}	Output Capacitance		7	pF

Note:

5. Tested initially and after any design or process changes that may affect these parameters.

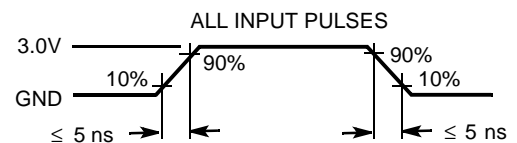
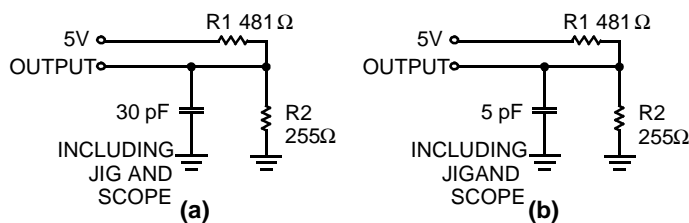
AC Test Loads and Waveforms

Equivalent to: THÉVENIN EQUIVALENT

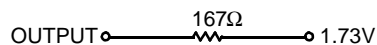

Switching Characteristics Over the Operating Range^[6]

Parameter	Description	7C185-15		7C185-20		7C185-25		7C185-35		Unit
		Min.	Max.	Min.	Max.	Min.	Max.	Min.	Max.	
Read Cycle										
t _{RC}	Read Cycle Time	15		20		25		35		ns
t _{AA}	Address to Data Valid		15		20		25		35	ns
t _{OHA}	Data Hold from Address Change	3		5		5		5		ns
t _{ACE1}	\overline{CE}_1 LOW to Data Valid		15		20		25		35	ns
t _{ACE2}	CE ₂ HIGH to Data Valid		15		20		25		35	ns
t _{DOE}	\overline{OE} LOW to Data Valid		8		9		12		15	ns
t _{LZOE}	\overline{OE} LOW to Low Z	3		3		3		3		ns
t _{HZOE}	\overline{OE} HIGH to High Z ^[7]		7		8		10		10	ns
t _{LZCE1}	\overline{CE}_1 LOW to Low Z ^[8]	3		5		5		5		ns
t _{LZCE2}	CE ₂ HIGH to Low Z	3		3		3		3		ns
t _{HZCE}	\overline{CE}_1 HIGH to High Z ^[7, 8] CE ₂ LOW to High Z		7		8		10		10	ns
t _{PU}	\overline{CE}_1 LOW to Power-Up CE ₂ to HIGH to Power-Up	0		0		0		0		ns
t _{PD}	\overline{CE}_1 HIGH to Power-Down CE ₂ LOW to Power-Down		15		20		20		20	ns
Write Cycle^[9]										
t _{WC}	Write Cycle Time	15		20		25		35		ns
t _{SCE1}	\overline{CE}_1 LOW to Write End	12		15		20		20		ns
t _{SCE2}	CE ₂ HIGH to Write End	12		15		20		20		ns
t _{AW}	Address Set-up to Write End	12		15		20		25		ns
t _{HA}	Address Hold from Write End	0		0		0		0		ns
t _{SA}	Address Set-up to Write Start	0		0		0		0		ns
t _{PWE}	\overline{WE} Pulse Width	12		15		15		20		ns
t _{SD}	Data Set-up to Write End	8		10		10		12		ns
t _{HD}	Data Hold from Write End	0		0		0		0		ns
t _{HZWE}	\overline{WE} LOW to High Z ^[7]		7		7		7		8	ns
t _{LZWE}	\overline{WE} HIGH to Low Z	3		5		5		5		ns

Notes:

- Test conditions assume signal transition time of 5 ns or less, timing reference levels of 1.5V, input pulse levels of 0 to 3.0V, and output loading of the specified I_{OL}/I_{OH} and 30-pF load capacitance.
- t_{HZOE}, t_{HZCE}, and t_{HZWE} are specified with C_L = 5 pF as in part (b) of AC Test Loads. Transition is measured ±500 mV from steady state voltage.
- At any given temperature and voltage condition, t_{HZCE} is less than t_{LZCE1} and t_{LZCE2} for any given device.
- The internal write time of the memory is defined by the overlap of CE₁ LOW, CE₂ HIGH, and WE LOW. All 3 signals must be active to initiate a write and either signal can terminate a write by going HIGH. The data input set-up and hold timing should be referenced to the rising edge of the signal that terminates the write.

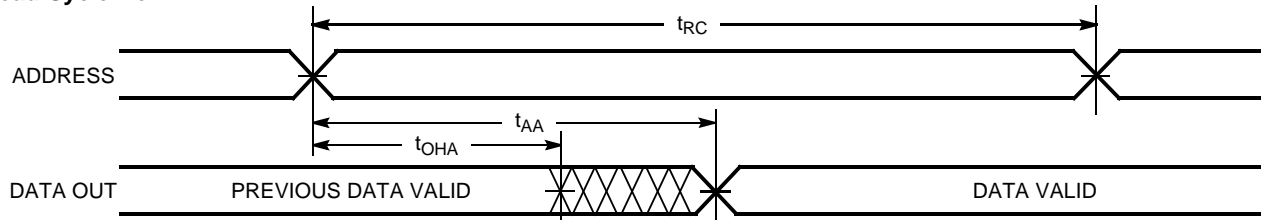
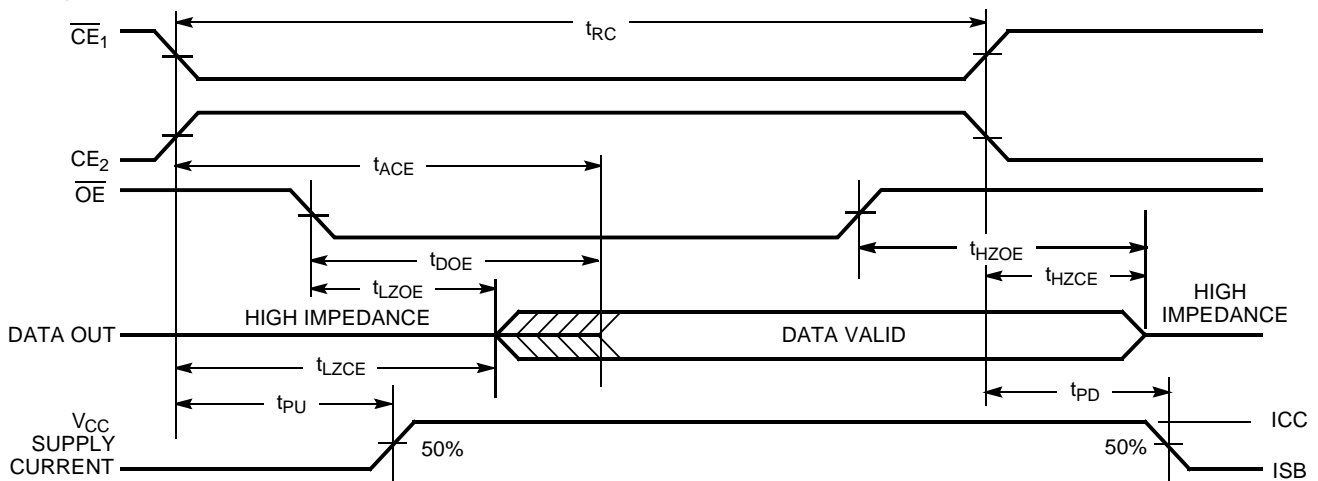
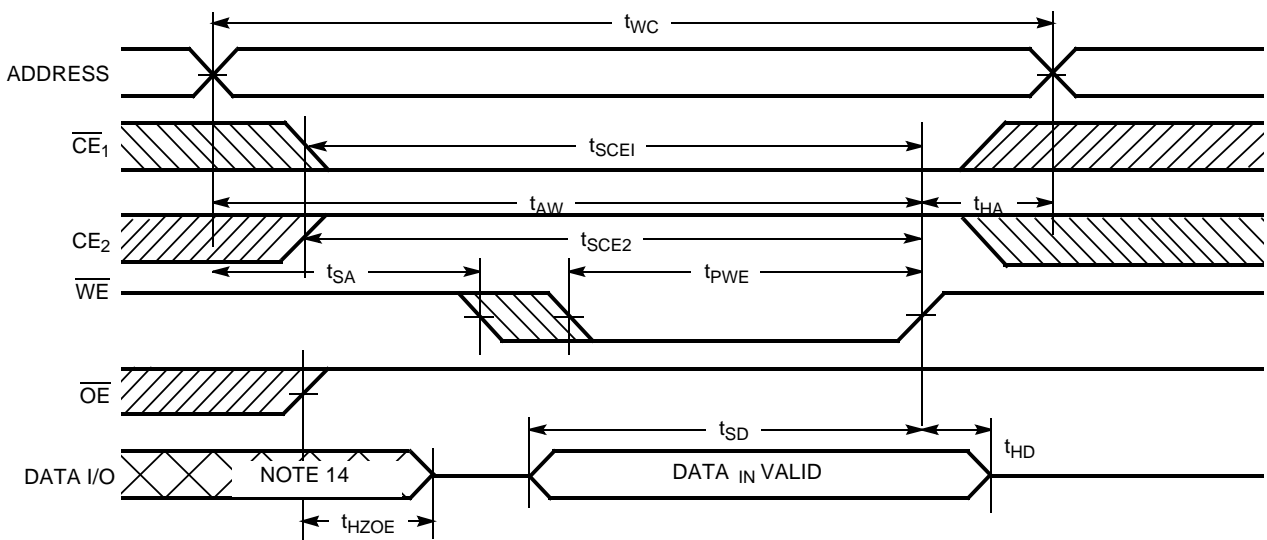
Switching Waveforms
Read Cycle No.1^[10,11]

Read Cycle No.2^[12,13]

Write Cycle No. 1 (\overline{WE} Controlled)^[11,13]

10. Device is continuously selected. \overline{OE} , $\overline{CE}_1 = V_{IL}$. $CE_2 = V_{IH}$.

11. WE is HIGH for read cycle.

12. Data I/O is High Z if $OE = V_{IH}$, $\overline{CE}_1 = V_{IH}$, $\overline{WE} = V_{IL}$, or $CE_2 = V_{IL}$.

13. The internal write time of the memory is defined by the overlap of \overline{CE}_1 LOW, CE_2 HIGH and \overline{WE} LOW. \overline{CE}_1 and \overline{WE} must be LOW and CE_2 must be HIGH to initiate write. A write can be terminated by \overline{CE}_1 or \overline{WE} going HIGH or CE_2 going LOW. The data input set-up and hold timing should be referenced to the rising edge of the signal that terminates the write.

14. During this period, the I/Os are in the output state and input signals should not be applied.

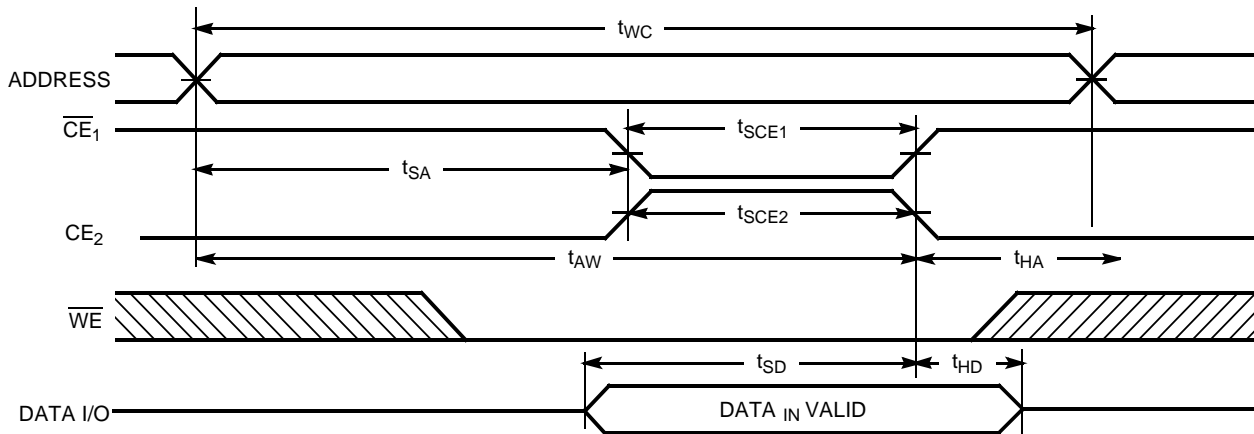
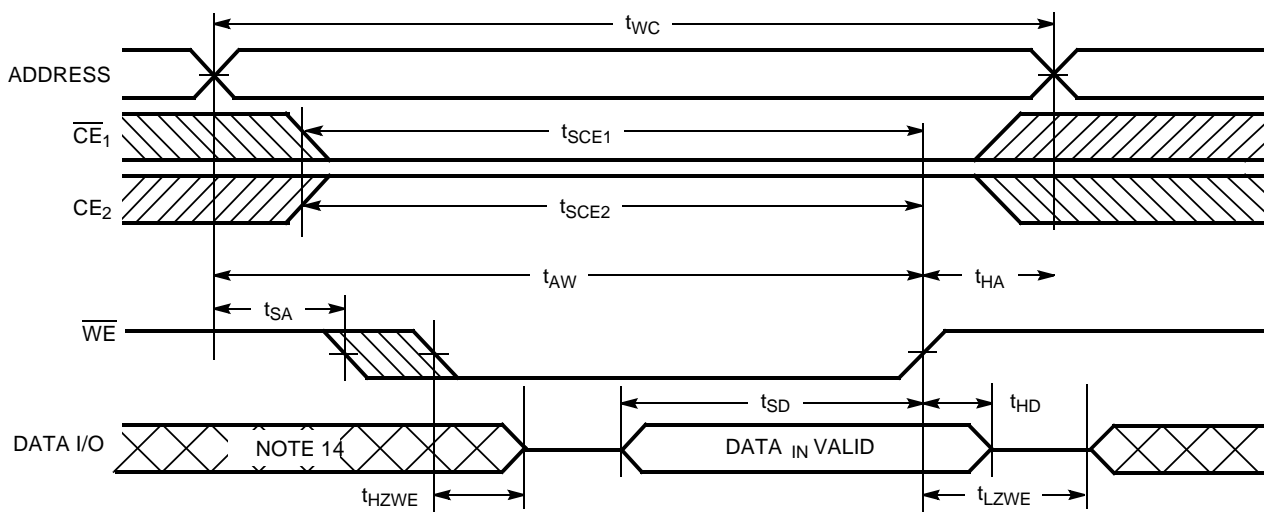
Switching Waveforms (continued)
Write Cycle No. 2 (\overline{CE} Controlled)^[13,14,15]

Write Cycle No. 3 (\overline{WE} Controlled, \overline{OE} LOW)^[13,14,15,16]

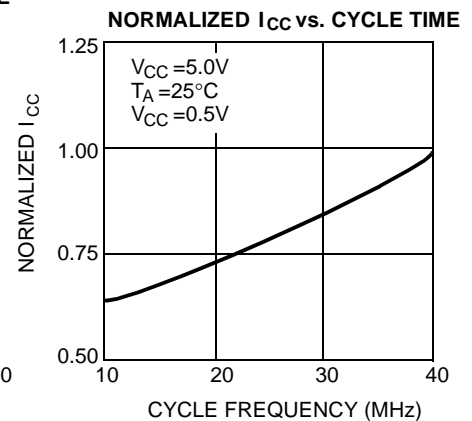
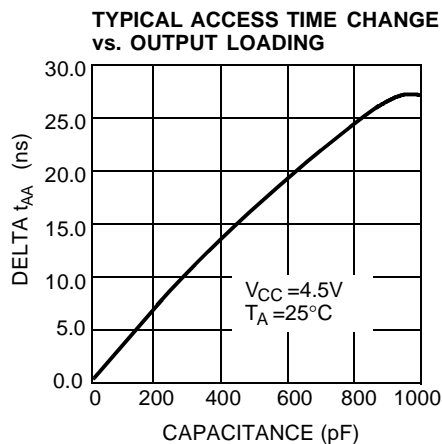
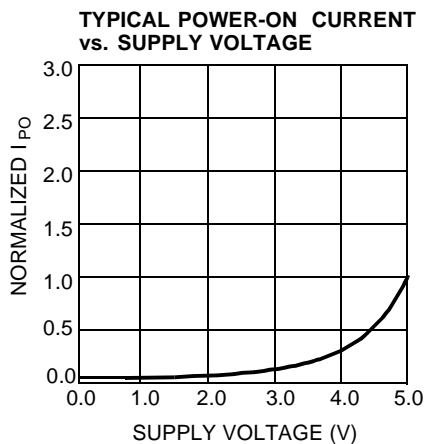
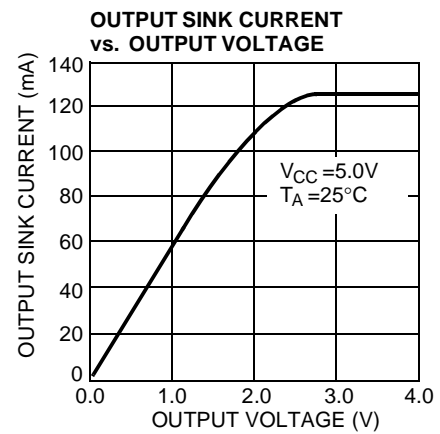
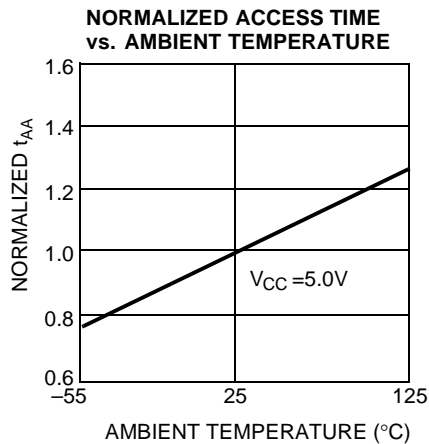
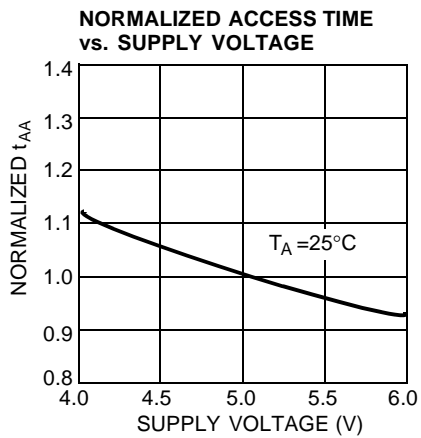
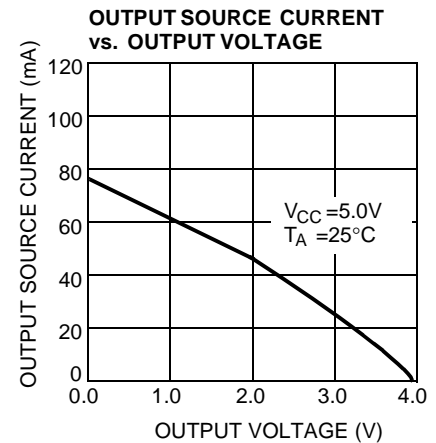
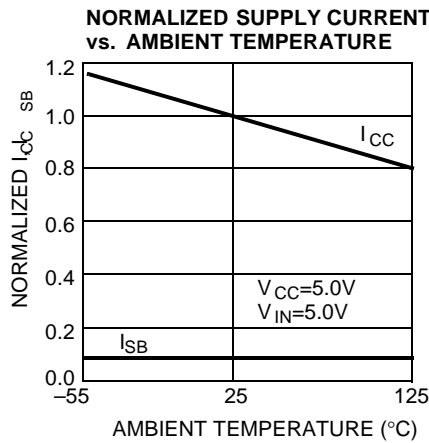
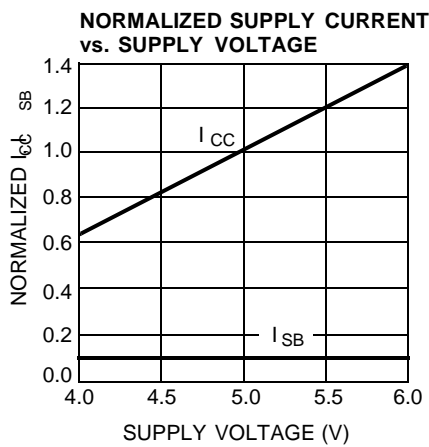
Notes:

15. The minimum write cycle time for write cycle #3 (\overline{WE} controlled, \overline{OE} LOW) is the sum of t_{HZWE} and t_{SD} .
16. If \overline{CE}_1 goes HIGH or CE_2 goes LOW simultaneously with \overline{WE} HIGH, the output remains in a high-impedance state.

Typical DC and AC Characteristics

Truth Table

CE ₁	CE ₂	WE	OE	Input/Output	Mode
H	X	X	X	High Z	Deselect/Power-Down
X	L	X	X	High Z	Deselect/Power-Down
L	H	H	L	Data Out	Read
L	H	L	X	Data In	Write
L	H	H	H	High Z	Deselect

Address Designators

Address Name	Address Function	Pin Number
A4	X3	2
A5	X4	3
A6	X5	4
A7	X6	5
A8	X7	6
A9	Y1	7
A10	Y4	8
A11	Y3	9
A12	Y0	10
A0	Y2	21
A1	X0	23
A2	X1	24
A3	X2	25

Ordering Information

Speed (ns)	Ordering Code	Package Name	Package Type	Operating Range
15	CY7C185-15PC	P21	28-Lead (300-Mil) Molded DIP	Commercial
	CY7C185-15SC	S21	28-Lead Molded SOIC	
	CY7C185-15VC	V21	28-Lead Molded SOJ	
	CY7C185-15VI	V21	28-Lead Molded SOJ	Industrial
20	CY7C185-20PC	P21	28-Lead (300-Mil) Molded DIP	Commercial
	CY7C185-20SC	S21	28-Lead Molded SOIC	
	CY7C185-20VC	V21	28-Lead Molded SOJ	
	CY7C185-20VI	V21	28-Lead Molded SOJ	Industrial
25	CY7C185-25PC	P21	28-Lead (300-Mil) Molded DIP	Commercial
	CY7C185-25SC	S21	28-Lead Molded SOIC	
	CY7C185-25VC	V21	28-Lead Molded SOJ	
	CY7C185-25VI	V21	28-Lead Molded SOJ	Industrial
35	CY7C185-35PC	P21	28-Lead (300-Mil) Molded DIP	Commercial
	CY7C185-35SC	S21	28-Lead Molded SOIC	
	CY7C185-35VC	V21	28-Lead Molded SOJ	
	CY7C185-35VI	V21	28-Lead Molded SOJ	Industrial

Package Diagrams

28-Lead (300-Mil) Molded DIP P21

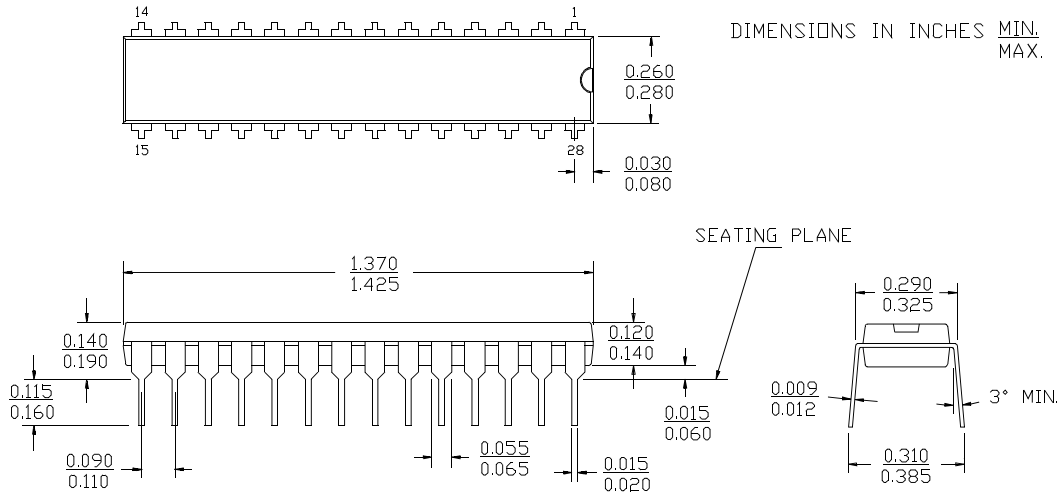

28-Lead (300-Mil) Molded SOIC S21

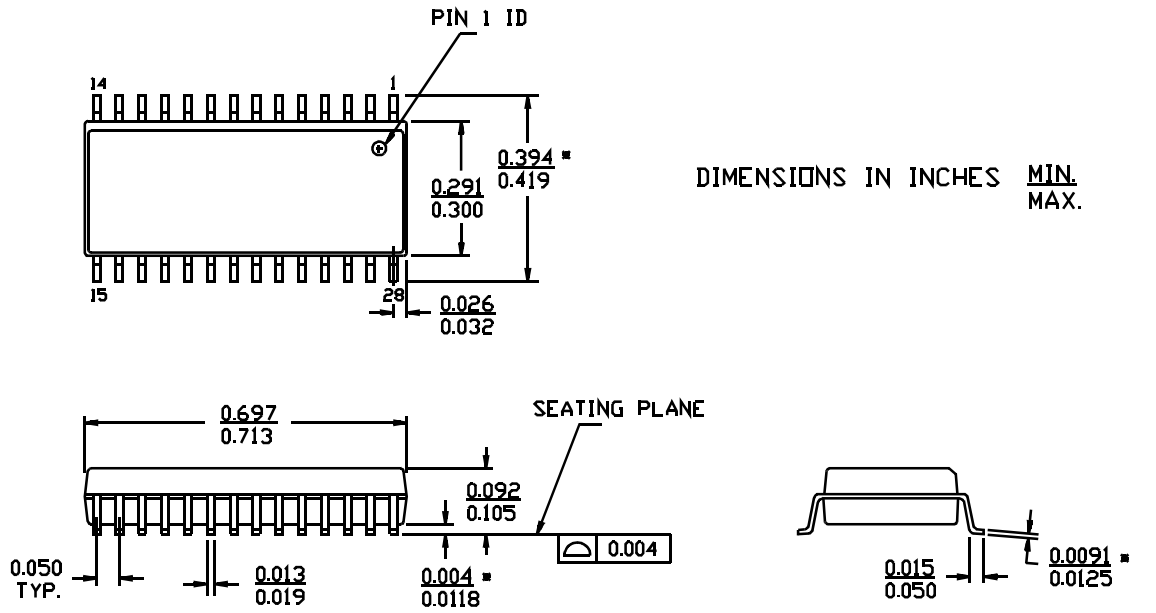

Package Diagrams (continued)

28-Lead (300-Mil) Molded SOJ V21

DIMENSIONS IN INCHES MIN.
MAX.

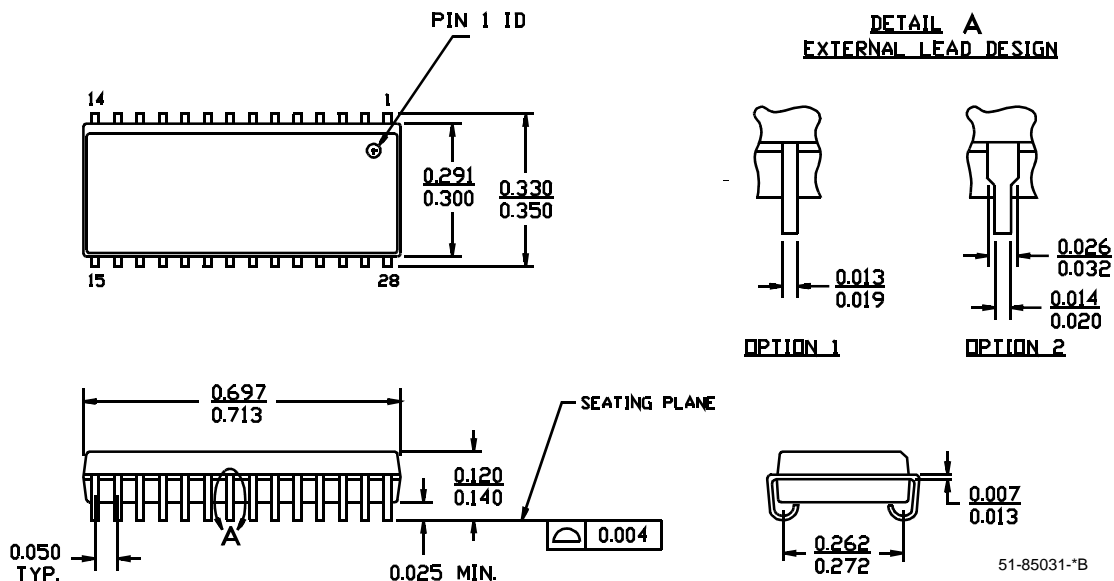



All product and company names mentioned in this document may be the trademarks of their respective holders.

Document History Page

Document Title: CY7C185 8K x 8 Static RAM Document Number: 38-05043				
REV.	ECN NO.	Issue Date	Orig. of Change	Description of Change
**	107145	09/10/01	SZV	Change from Spec number: 38-00037 to 38-05043
*A	116470	09/16/02	CEA	Add applications foot note to data sheet.

Looking for pricing, stock, or lifecycle information?

Click below to explore more details on WIN SOURCE:

-  [View CY7C185-35VC on WIN SOURCE](#)
-  [Cypress Semiconductor Corp Information](#)

Optimize Your Supply Chain with WIN SOURCE Solutions

-  Global Sourcing Solution
-  Obsolete Management
-  Cost Control Management
-  Shortage Management
-  Alternative Solution
-  Excess Inventory Management