



**THE DATASHEET OF
CY7C1514KV18-250BZC**





CY7C1525KV18
 CY7C1512KV18
 CY7C1514KV18

72-Mbit QDR[®] II SRAM Two-Word Burst Architecture

Features

- Separate independent read and write data ports
 - Supports concurrent transactions
- 350 MHz clock for high bandwidth
- Two-word burst on all accesses
- Double data rate (DDR) interfaces on both read and write ports (data transferred at 700 MHz) at 350 MHz
- Two input clocks (K and \bar{K}) for precise DDR timing
 - SRAM uses rising edges only
- Two input clocks for output data (C and \bar{C}) to minimize clock skew and flight time mismatches
- Echo clocks (CQ and \bar{CQ}) simplify data capture in high speed systems
- Single multiplexed address input bus latches address inputs for both read and write ports
- Separate port selects for depth expansion
- Synchronous internally self-timed writes
- QDR[®] II operates with 1.5 cycle read latency when \overline{DOFF} is asserted HIGH
- Operates similar to QDR I device with 1 cycle read latency when \overline{DOFF} is asserted LOW
- Available in $\times 9$, $\times 18$, and $\times 36$ configurations
- Full data coherency, providing most current data
- Core $V_{DD} = 1.8\text{ V}$ ($\pm 0.1\text{ V}$); I/O $V_{DDQ} = 1.4\text{ V}$ to V_{DD}
 - Supports both 1.5 V and 1.8 V I/O supply
- Available in 165-ball fine pitch ball grid array (FBGA) package (13 \times 15 \times 1.4 mm)
- Offered in both Pb-free and non Pb-free packages
- Variable drive HSTL output buffers
- JTAG 1149.1 compatible test access port
- Phase Locked Loop (PLL) for Accurate Data Placement

Configurations

- CY7C1525KV18 – 8M \times 9
- CY7C1512KV18 – 4M \times 18
- CY7C1514KV18 – 2M \times 36

Functional Description

The CY7C1525KV18, CY7C1512KV18, and CY7C1514KV18 are 1.8 V synchronous pipelined SRAMs, equipped with QDR II architecture. QDR II architecture consists of two separate ports: the read port and the write port to access the memory array. The read port has dedicated data outputs to support read operations and the write port has dedicated data inputs to support write operations. QDR II architecture has separate data inputs and data outputs to completely eliminate the need to “turnaround” the data bus that exists with common I/O devices. Access to each port is through a common address bus. Addresses for read and write addresses are latched on alternate rising edges of the input (K) clock. Accesses to the QDR II read and write ports are completely independent of one another. To maximize data throughput, both read and write ports are equipped with DDR interfaces. Each address location is associated with 9-bit words (CY7C1525KV18), 18-bit words (CY7C1512KV18), or 36-bit words (CY7C1514KV18) that burst sequentially into or out of the device. Because data can be transferred into and out of the device on every rising edge of both input clocks (K and \bar{K} and C and \bar{C}), memory bandwidth is maximized while simplifying system design by eliminating bus turnarounds.

Depth expansion is accomplished with port selects, which enables each port to operate independently.

All synchronous inputs pass through input registers controlled by the K or \bar{K} input clocks. All data outputs pass through output registers controlled by the C or \bar{C} (or K or \bar{K} in a single clock domain) input clocks. Writes are conducted with on-chip synchronous self-timed write circuitry.

For a complete list of related documentation, click [here](#).

Selection Guide

| Description | | 350 MHz | 333 MHz | 300 MHz | 250 MHz | Unit |
|-----------------------------|-------------|-------------|---------|---------|---------|------|
| Maximum operating frequency | | 350 | 333 | 300 | 250 | MHz |
| Maximum operating current | $\times 9$ | Not Offered | 790 | 730 | 640 | mA |
| | $\times 18$ | 840 | 810 | 750 | 650 | |
| | $\times 36$ | Not Offered | 990 | 910 | 790 | |



Logic Block Diagram – CY7C1525KV18

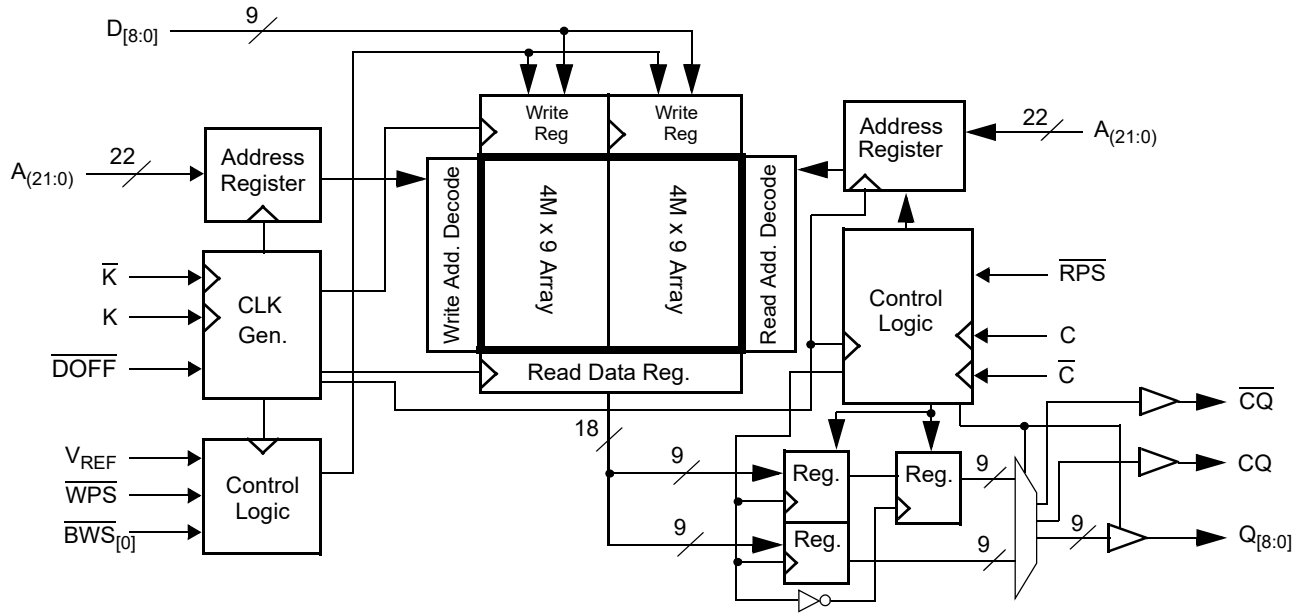



Logic Block Diagram – CY7C1512KV18

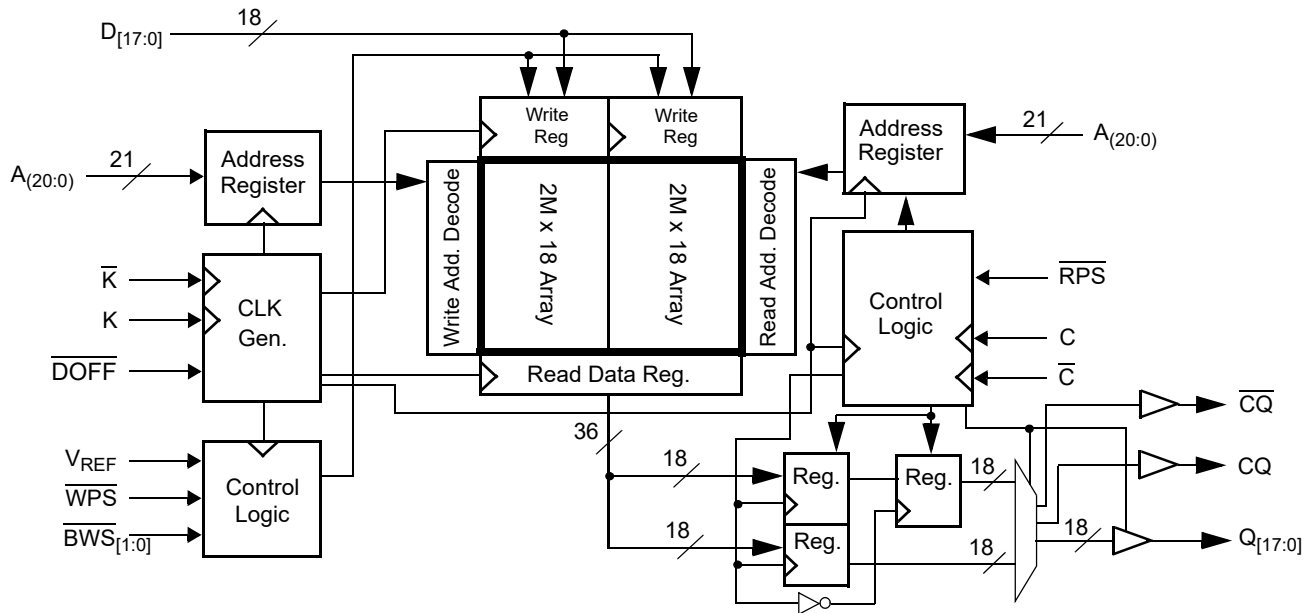

Logic Block Diagram – CY7C1514KV18

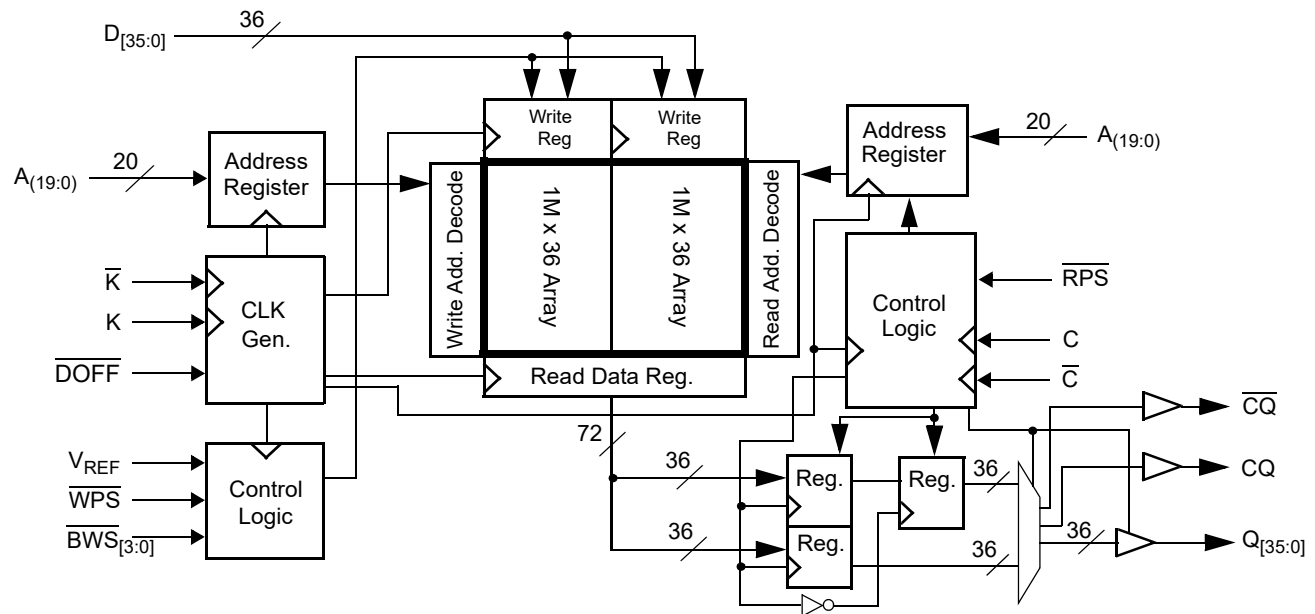



Contents

| | | | |
|--|-----------|--|-----------|
| Pin Configurations | 5 | Instruction Codes | 19 |
| Pin Definitions | 7 | Boundary Scan Order | 20 |
| Functional Overview | 8 | Power Up Sequence in QDR II SRAM | 21 |
| Read Operations | 8 | Power Up Sequence | 21 |
| Write Operations | 9 | PLL Constraints | 21 |
| Byte Write Operations | 9 | Maximum Ratings | 22 |
| Single Clock Mode | 9 | Operating Range | 22 |
| Concurrent Transactions | 9 | Neutron Soft Error Immunity | 22 |
| Depth Expansion | 9 | Electrical Characteristics | 22 |
| Programmable Impedance | 9 | DC Electrical Characteristics | 22 |
| Echo Clocks | 9 | AC Electrical Characteristics | 24 |
| PLL | 9 | Capacitance | 24 |
| Application Example | 10 | Thermal Resistance | 24 |
| Truth Table | 11 | AC Test Loads and Waveforms | 24 |
| Write Cycle Descriptions | 11 | Switching Characteristics | 25 |
| Write Cycle Descriptions | 12 | Switching Waveforms | 27 |
| Write Cycle Descriptions | 12 | Read/Write/Deselect Sequence | 27 |
| IEEE 1149.1 Serial Boundary Scan (JTAG) | 13 | Ordering Information | 28 |
| Disabling the JTAG Feature | 13 | Ordering Code Definitions | 29 |
| Test Access Port | 13 | Package Diagram | 30 |
| Performing a TAP Reset | 13 | Acronyms | 31 |
| TAP Registers | 13 | Document Conventions | 31 |
| TAP Instruction Set | 13 | Units of Measure | 31 |
| TAP Controller State Diagram | 15 | Document History Page | 32 |
| TAP Controller Block Diagram | 16 | Sales, Solutions, and Legal Information | 35 |
| TAP Electrical Characteristics | 16 | Worldwide Sales and Design Support | 35 |
| TAP AC Switching Characteristics | 17 | Products | 35 |
| TAP Timing and Test Conditions | 18 | PSoC® Solutions | 35 |
| Identification Register Definitions | 19 | Cypress Developer Community | 35 |
| Scan Register Sizes | 19 | Technical Support | 35 |



Pin Configurations

The pin configurations for CY7C1525KV18, CY7C1512KV18, and CY7C1514KV18 follow. [1]

**Figure 1. 165-ball FBGA (13 × 15 × 1.4 mm) pinout
 CY7C1525KV18 (8M × 9)**

| | 1 | 2 | 3 | 4 | 5 | 6 | 7 | 8 | 9 | 10 | 11 |
|----------|--------------------------|-----------|-----------|-------------------------|----------|-----------------------|---------------------------|-------------------------|-----------|-----------|-----|
| A | $\overline{\text{CQ}}$ | A | A | $\overline{\text{WPS}}$ | NC | $\overline{\text{K}}$ | NC/144M | $\overline{\text{RPS}}$ | A | A | CQ |
| B | NC | NC | NC | A | NC/288M | K | $\overline{\text{BWS}}_0$ | A | NC | NC | Q4 |
| C | NC | NC | NC | V_{SS} | A | A | A | V_{SS} | NC | NC | D4 |
| D | NC | D5 | NC | V_{SS} | V_{SS} | V_{SS} | V_{SS} | V_{SS} | NC | NC | NC |
| E | NC | NC | Q5 | V_{DDQ} | V_{SS} | V_{SS} | V_{SS} | V_{DDQ} | NC | D3 | Q3 |
| F | NC | NC | NC | V_{DDQ} | V_{DD} | V_{SS} | V_{DD} | V_{DDQ} | NC | NC | NC |
| G | NC | D6 | Q6 | V_{DDQ} | V_{DD} | V_{SS} | V_{DD} | V_{DDQ} | NC | NC | NC |
| H | $\overline{\text{DOFF}}$ | V_{REF} | V_{DDQ} | V_{DDQ} | V_{DD} | V_{SS} | V_{DD} | V_{DDQ} | V_{DDQ} | V_{REF} | ZQ |
| J | NC | NC | NC | V_{DDQ} | V_{DD} | V_{SS} | V_{DD} | V_{DDQ} | NC | Q2 | D2 |
| K | NC | NC | NC | V_{DDQ} | V_{DD} | V_{SS} | V_{DD} | V_{DDQ} | NC | NC | NC |
| L | NC | Q7 | D7 | V_{DDQ} | V_{SS} | V_{SS} | V_{SS} | V_{DDQ} | NC | NC | Q1 |
| M | NC | NC | NC | V_{SS} | V_{SS} | V_{SS} | V_{SS} | V_{SS} | NC | NC | D1 |
| N | NC | D8 | NC | V_{SS} | A | A | A | V_{SS} | NC | NC | NC |
| P | NC | NC | Q8 | A | A | C | A | A | NC | D0 | Q0 |
| R | TDO | TCK | A | A | A | $\overline{\text{C}}$ | A | A | A | TMS | TDI |

Note

1. NC/144M and NC/288M are not connected to the die and can be tied to any voltage level.



Pin Configurations (continued)

The pin configurations for CY7C1525KV18, CY7C1512KV18, and CY7C1514KV18 follow. [1]

Figure 1. 165-ball FBGA (13 × 15 × 1.4 mm) pinout

CY7C1512KV18 (4M × 18)

| | 1 | 2 | 3 | 4 | 5 | 6 | 7 | 8 | 9 | 10 | 11 |
|----------|--------------------------|-----------|-----------|-------------------------|---------------------------|-----------------------|---------------------------|-------------------------|-----------|-----------|-----|
| A | $\overline{\text{CQ}}$ | NC/144M | A | $\overline{\text{WPS}}$ | $\overline{\text{BWS}}_1$ | $\overline{\text{K}}$ | NC/288M | $\overline{\text{RPS}}$ | A | A | CQ |
| B | NC | Q9 | D9 | A | NC | K | $\overline{\text{BWS}}_0$ | A | NC | NC | Q8 |
| C | NC | NC | D10 | V_{SS} | A | A | A | V_{SS} | NC | Q7 | D8 |
| D | NC | D11 | Q10 | V_{SS} | V_{SS} | V_{SS} | V_{SS} | V_{SS} | NC | NC | D7 |
| E | NC | NC | Q11 | V_{DDQ} | V_{SS} | V_{SS} | V_{SS} | V_{DDQ} | NC | D6 | Q6 |
| F | NC | Q12 | D12 | V_{DDQ} | V_{DD} | V_{SS} | V_{DD} | V_{DDQ} | NC | NC | Q5 |
| G | NC | D13 | Q13 | V_{DDQ} | V_{DD} | V_{SS} | V_{DD} | V_{DDQ} | NC | NC | D5 |
| H | $\overline{\text{DOFF}}$ | V_{REF} | V_{DDQ} | V_{DDQ} | V_{DD} | V_{SS} | V_{DD} | V_{DDQ} | V_{DDQ} | V_{REF} | ZQ |
| J | NC | NC | D14 | V_{DDQ} | V_{DD} | V_{SS} | V_{DD} | V_{DDQ} | NC | Q4 | D4 |
| K | NC | NC | Q14 | V_{DDQ} | V_{DD} | V_{SS} | V_{DD} | V_{DDQ} | NC | D3 | Q3 |
| L | NC | Q15 | D15 | V_{DDQ} | V_{SS} | V_{SS} | V_{SS} | V_{DDQ} | NC | NC | Q2 |
| M | NC | NC | D16 | V_{SS} | V_{SS} | V_{SS} | V_{SS} | V_{SS} | NC | Q1 | D2 |
| N | NC | D17 | Q16 | V_{SS} | A | A | A | V_{SS} | NC | NC | D1 |
| P | NC | NC | Q17 | A | A | $\overline{\text{C}}$ | A | A | NC | D0 | Q0 |
| R | TDO | TCK | A | A | A | $\overline{\text{C}}$ | A | A | A | TMS | TDI |

CY7C1514KV18 (2M × 36)

| | 1 | 2 | 3 | 4 | 5 | 6 | 7 | 8 | 9 | 10 | 11 |
|----------|--------------------------|-----------|-----------|-------------------------|---------------------------|-----------------------|---------------------------|-------------------------|-----------|-----------|-----|
| A | $\overline{\text{CQ}}$ | NC/288M | A | $\overline{\text{WPS}}$ | $\overline{\text{BWS}}_2$ | $\overline{\text{K}}$ | $\overline{\text{BWS}}_1$ | $\overline{\text{RPS}}$ | A | NC/144M | CQ |
| B | Q27 | Q18 | D18 | A | $\overline{\text{BWS}}_3$ | K | $\overline{\text{BWS}}_0$ | A | D17 | Q17 | Q8 |
| C | D27 | Q28 | D19 | V_{SS} | A | A | A | V_{SS} | D16 | Q7 | D8 |
| D | D28 | D20 | Q19 | V_{SS} | V_{SS} | V_{SS} | V_{SS} | V_{SS} | Q16 | D15 | D7 |
| E | Q29 | D29 | Q20 | V_{DDQ} | V_{SS} | V_{SS} | V_{SS} | V_{DDQ} | Q15 | D6 | Q6 |
| F | Q30 | Q21 | D21 | V_{DDQ} | V_{DD} | V_{SS} | V_{DD} | V_{DDQ} | D14 | Q14 | Q5 |
| G | D30 | D22 | Q22 | V_{DDQ} | V_{DD} | V_{SS} | V_{DD} | V_{DDQ} | Q13 | D13 | D5 |
| H | $\overline{\text{DOFF}}$ | V_{REF} | V_{DDQ} | V_{DDQ} | V_{DD} | V_{SS} | V_{DD} | V_{DDQ} | V_{DDQ} | V_{REF} | ZQ |
| J | D31 | Q31 | D23 | V_{DDQ} | V_{DD} | V_{SS} | V_{DD} | V_{DDQ} | D12 | Q4 | D4 |
| K | Q32 | D32 | Q23 | V_{DDQ} | V_{DD} | V_{SS} | V_{DD} | V_{DDQ} | Q12 | D3 | Q3 |
| L | Q33 | Q24 | D24 | V_{DDQ} | V_{SS} | V_{SS} | V_{SS} | V_{DDQ} | D11 | Q11 | Q2 |
| M | D33 | Q34 | D25 | V_{SS} | V_{SS} | V_{SS} | V_{SS} | V_{SS} | D10 | Q1 | D2 |
| N | D34 | D26 | Q25 | V_{SS} | A | A | A | V_{SS} | Q10 | D9 | D1 |
| P | Q35 | D35 | Q26 | A | A | $\overline{\text{C}}$ | A | A | Q9 | D0 | Q0 |
| R | TDO | TCK | A | A | A | $\overline{\text{C}}$ | A | A | A | TMS | TDI |



Pin Definitions

| Pin Name | I/O | Pin Description |
|--|--------------------|--|
| $D_{[x:0]}$ | Input-Synchronous | Data input signals. Sampled on the rising edge of K and \bar{K} clocks during valid write operations. CY7C1525KV18 – $D_{[8:0]}$ CY7C1512KV18 – $D_{[17:0]}$ CY7C1514KV18 – $D_{[35:0]}$ |
| \overline{WPS} | Input-Synchronous | Write Port Select – Active LOW. Sampled on the rising edge of the K clock. When asserted active, a write operation is initiated. Deasserting deselects the write port. Deselecting the write port ignores $D_{[x:0]}$. |
| \overline{BWS}_0 , \overline{BWS}_1 , \overline{BWS}_2 , \overline{BWS}_3 | Input-Synchronous | Byte Write Select 0, 1, 2, and 3 – Active LOW. Sampled on the rising edge of the K and \bar{K} clocks during write operations. Used to select which byte is written into the device during the current portion of the write operations. Bytes not written remain unaltered. CY7C1525KV18 – \overline{BWS}_0 controls $D_{[8:0]}$. CY7C1512KV18 – \overline{BWS}_0 controls $D_{[8:0]}$ and \overline{BWS}_1 controls $D_{[17:9]}$. CY7C1514KV18 – \overline{BWS}_0 controls $D_{[8:0]}$, \overline{BWS}_1 controls $D_{[17:9]}$, \overline{BWS}_2 controls $D_{[26:18]}$ and \overline{BWS}_3 controls $D_{[35:27]}$. All the Byte Write Selects are sampled on the same edge as the data. Deselecting a Byte Write Select ignores the corresponding byte of data and it is not written into the device. |
| A | Input-Synchronous | Address inputs. Sampled on the rising edge of the K (read address) and \bar{K} (write address) clocks during active read and write operations. These address inputs are multiplexed for both read and write operations. Internally, the device is organized as $8M \times 9$ (2 arrays each of $4M \times 9$) for CY7C1525KV18, $4M \times 18$ (2 arrays each of $2M \times 18$) for CY7C1512KV18, and $2M \times 36$ (2 arrays each of $1M \times 36$) for CY7C1514KV18. Therefore, only 22 address inputs are needed to access the entire memory array of CY7C1525KV18, 21 address inputs for CY7C1512KV18, and 20 address inputs for CY7C1514KV18. These inputs are ignored when the appropriate port is deselected. |
| $Q_{[x:0]}$ | Output-Synchronous | Data output signals. These pins drive out the requested data during a read operation. Valid data is driven out on the rising edge of the C and \bar{C} clocks during read operations, or K and \bar{K} when in single clock mode. When the read port is deselected, $Q_{[x:0]}$ are automatically tristated. CY7C1525KV18 – $Q_{[8:0]}$ CY7C1512KV18 – $Q_{[17:0]}$ CY7C1514KV18 – $Q_{[35:0]}$ |
| \overline{RPS} | Input-Synchronous | Read Port Select – Active LOW. Sampled on the rising edge of positive input clock (K). When active, a read operation is initiated. Deasserting deselects the read port. When deselected, the pending access is allowed to complete and the output drivers are automatically tristated following the next rising edge of the C clock. Each read access consists of a burst of two sequential transfers. |
| C | Input Clock | Positive input clock for output data. C is used in conjunction with \bar{C} to clock out the read data from the device. Use C and \bar{C} together to deskew the flight times of various devices on the board back to the controller. See Application Example on page 10 for further details. |
| \bar{C} | Input Clock | Negative input clock for output data. \bar{C} is used in conjunction with C to clock out the read data from the device. Use C and \bar{C} together to deskew the flight times of various devices on the board back to the controller. See Application Example on page 10 for further details. |
| K | Input Clock | Positive input clock input. The rising edge of K is used to capture synchronous inputs to the device and to drive out data through $Q_{[x:0]}$ when in single clock mode. All accesses are initiated on the rising edge of K. |
| \bar{K} | Input Clock | Negative input clock input. \bar{K} is used to capture synchronous inputs being presented to the device and to drive out data through $Q_{[x:0]}$ when in single clock mode. |
| CQ | Echo Clock | CQ referenced with respect to C. This is a free running clock and is synchronized to the input clock for output data (C) of the QDR II. In single clock mode, CQ is generated with respect to K. The timing for the echo clocks is shown in Switching Characteristics on page 25 . |
| $\bar{C}Q$ | Echo Clock | CQ referenced with respect to \bar{C}. This is a free running clock and is synchronized to the input clock for output data (\bar{C}) of the QDR II. In single clock mode, $\bar{C}Q$ is generated with respect to \bar{K} . The timing for the echo clocks is shown in the Switching Characteristics on page 25 . |



Pin Definitions (continued)

| Pin Name | I/O | Pin Description |
|-------------------|-----------------|---|
| ZQ | Input | Output impedance matching input. This input is used to tune the device outputs to the system data bus impedance. CQ , \overline{CQ} , and $Q_{[x:0]}$ output impedance are set to $0.2 \times RQ$, where RQ is a resistor connected between ZQ and ground. Alternatively, connect this pin directly to V_{DDQ} , which enables the minimum impedance mode. This pin cannot be connected directly to GND or left unconnected. |
| \overline{DOFF} | Input | PLL turn off – Active LOW. Connecting this pin to ground turns off the PLL inside the device. The timing in the operation with the PLL turned off differs from those listed in this data sheet. For normal operation, connect this pin to a pull up through a 10 k Ω or less pull up resistor. The device behaves in QDR I mode when the PLL is turned off. In this mode, the device can be operated at a frequency of up to 167 MHz with QDR I timing. |
| TDO | Output | Test data out (TDO) pin for JTAG. |
| TCK | Input | Test clock (TCK) pin for JTAG. |
| TDI | Input | Test data in (TDI) pin for JTAG. |
| TMS | Input | Test mode select (TMS) pin for JTAG. |
| NC | N/A | Not connected to the die. Can be tied to any voltage level. |
| NC/144M | Input | Not connected to the die. Can be tied to any voltage level. |
| NC/288M | Input | Not connected to the die. Can be tied to any voltage level. |
| V_{REF} | Input-Reference | Reference voltage input. Static input used to set the reference level for HSTL inputs, outputs, and AC measurement points. |
| V_{DD} | Power Supply | Power supply inputs to the core of the device. |
| V_{SS} | Ground | Ground for the device. |
| V_{DDQ} | Power Supply | Power supply inputs for the outputs of the device. |

Functional Overview

The CY7C1525KV18, CY7C1512KV18, and CY7C1514KV18 are synchronous pipelined Burst SRAMs with a read port and a write port. The read port is dedicated to read operations and the write port is dedicated to write operations. Data flows into the SRAM through the write port and flows out through the read port. These devices multiplex the address inputs to minimize the number of address pins required. By having separate read and write ports, the QDR II completely eliminates the need to turn around the data bus and avoids any possible data contention, thereby simplifying system design. Each access consists of two 9-bit data transfers in the case of CY7C1525KV18, two 18-bit data transfers in the case of CY7C1512KV18, and two 36-bit data transfers in the case of CY7C1514KV18 in one clock cycle.

This device operates with a read latency of one and half cycles when \overline{DOFF} pin is tied HIGH. When \overline{DOFF} pin is set LOW or connected to V_{SS} then the device behaves in QDR I mode with a read latency of one clock cycle.

Accesses for both ports are initiated on the rising edge of the positive input clock (K). All synchronous input timing is referenced from the rising edge of the input clocks (K and \overline{K}) and all output timing is referenced to the output clocks (C and \overline{C} , or K and \overline{K} when in single clock mode).

All synchronous data inputs ($D_{[x:0]}$) pass through input registers controlled by the input clocks (K and \overline{K}). All synchronous data outputs ($Q_{[x:0]}$) pass through output registers controlled by the

rising edge of the output clocks (C and \overline{C} , or K and \overline{K} when in single clock mode).

All synchronous control (\overline{RPS} , \overline{WPS} , $\overline{BWS}_{[x:0]}$) inputs pass through input registers controlled by the rising edge of the input clocks (K and \overline{K}).

CY7C1512KV18 is described in the following sections. The same basic descriptions apply to CY7C1525KV18, and CY7C1514KV18.

Read Operations

The CY7C1512KV18 is organized internally as two arrays of $2M \times 18$. Accesses are completed in a burst of two sequential 18-bit data words. Read operations are initiated by asserting \overline{RPS} active at the rising edge of the positive input clock (K). The address is latched on the rising edge of the K clock. The address presented to the address inputs is stored in the read address register. Following the next K clock rise, the corresponding lowest order 18-bit word of data is driven onto the $Q_{[17:0]}$ using \overline{C} as the output timing reference. On the subsequent rising edge of C, the next 18-bit data word is driven onto the $Q_{[17:0]}$. The requested data is valid 0.45 ns from the rising edge of the output clock (C and \overline{C} or K and \overline{K} when in single clock mode).

Synchronous internal circuitry automatically tristates the outputs following the next rising edge of the output clocks ($\overline{C}/\overline{C}$). This enables for a seamless transition between devices without the insertion of wait states in a depth expanded memory.



Write Operations

Write operations are initiated by asserting \overline{WPS} active at the rising edge of the positive input clock (K). On the same K clock rise the data presented to $D_{[17:0]}$ is latched and stored into the lower 18-bit write data register, provided $BWS_{[1:0]}$ are both asserted active. On the subsequent rising edge of the negative input clock (\overline{K}), the address is latched and the information presented to $D_{[17:0]}$ is also stored into the write data register, provided $BWS_{[1:0]}$ are both asserted active. The 36 bits of data are then written into the memory array at the specified location.

When deselected, the write port ignores all inputs after the pending write operations are completed.

Byte Write Operations

Byte write operations are supported by the CY7C1512KV18. A write operation is initiated as described in the [Write Operations section](#). The bytes that are written are determined by BWS_0 and BWS_1 , which are sampled with each set of 18-bit data words. Asserting the appropriate Byte Write Select input during the data portion of a write latches the data being presented and writes it into the device. Deasserting the Byte write select input during the data portion of a write enables the data stored in the device for that byte to remain unaltered. This feature is used to simplify read, modify, or write operations to a byte write operation.

Single Clock Mode

The CY7C1512KV18 is used with a single clock that controls both the input and output registers. In this mode the device recognizes only a single pair of input clocks (K and \overline{K}) that control both the input and output registers. This operation is identical to the operation if the device had zero skew between the K/\overline{K} and C/\overline{C} clocks. All timing parameters remain the same in this mode. To use this mode of operation, the user must tie C and \overline{C} HIGH at power on. This function is a strap option and not alterable during device operation.

Concurrent Transactions

The read and write ports on the CY7C1512KV18 operate completely independently of one another. As each port latches the address inputs on different clock edges, the user can read or write to any location, regardless of the transaction on the other port. The user can start reads and writes in the same clock cycle. If the ports access the same location at the same time, the SRAM delivers the most recent information associated with the

specified address location. This includes forwarding data from a write cycle that was initiated on the previous K clock rise.

Depth Expansion

The CY7C1512KV18 has a port select input for each port. This enables for easy depth expansion. Both port selects are sampled on the rising edge of the positive input clock only (K). Each port select input can deselect the specified port. Deselecting a port does not affect the other port. All pending transactions (read and write) are completed before the device is deselected.

Programmable Impedance

An external resistor, RQ, must be connected between the ZQ pin on the SRAM and V_{SS} to enable the SRAM to adjust its output driver impedance. The value of RQ must be $5 \times$ the value of the intended line impedance driven by the SRAM. The allowable range of RQ to guarantee impedance matching with a tolerance of $\pm 15\%$ is between 175Ω and 350Ω , with $V_{DDQ} = 1.5 \text{ V}$. The output impedance is adjusted every 1024 cycles upon power up to account for drifts in supply voltage and temperature.

Echo Clocks

Echo clocks are provided on the QDR II to simplify data capture on high speed systems. Two echo clocks are generated by the QDR II. CQ is referenced with respect to C and \overline{CQ} is referenced with respect to \overline{C} . These are free running clocks and are synchronized to the output clock of the QDR II. In the single clock mode, CQ is generated with respect to K and \overline{CQ} is generated with respect to \overline{K} . The timing for the echo clocks is shown in [Switching Characteristics on page 25](#).

PLL

These chips use a PLL that is designed to function between 120 MHz and the specified maximum clock frequency. During power up, when the DOFF is tied HIGH, the PLL is locked after $20 \mu\text{s}$ of stable clock. The PLL can also be reset by slowing or stopping the input clocks K and \overline{K} for a minimum of 30 ns. However, it is not necessary to reset the PLL to lock to the desired frequency. The PLL automatically locks $20 \mu\text{s}$ after a stable clock is presented. The PLL may be disabled by applying ground to the DOFF pin. When the PLL is turned off, the device behaves in QDR I mode (with one cycle latency and a longer access time).



Application Example

Figure 2 shows two QDR II used in an application.

Figure 2. Application Example (Width Expansion)

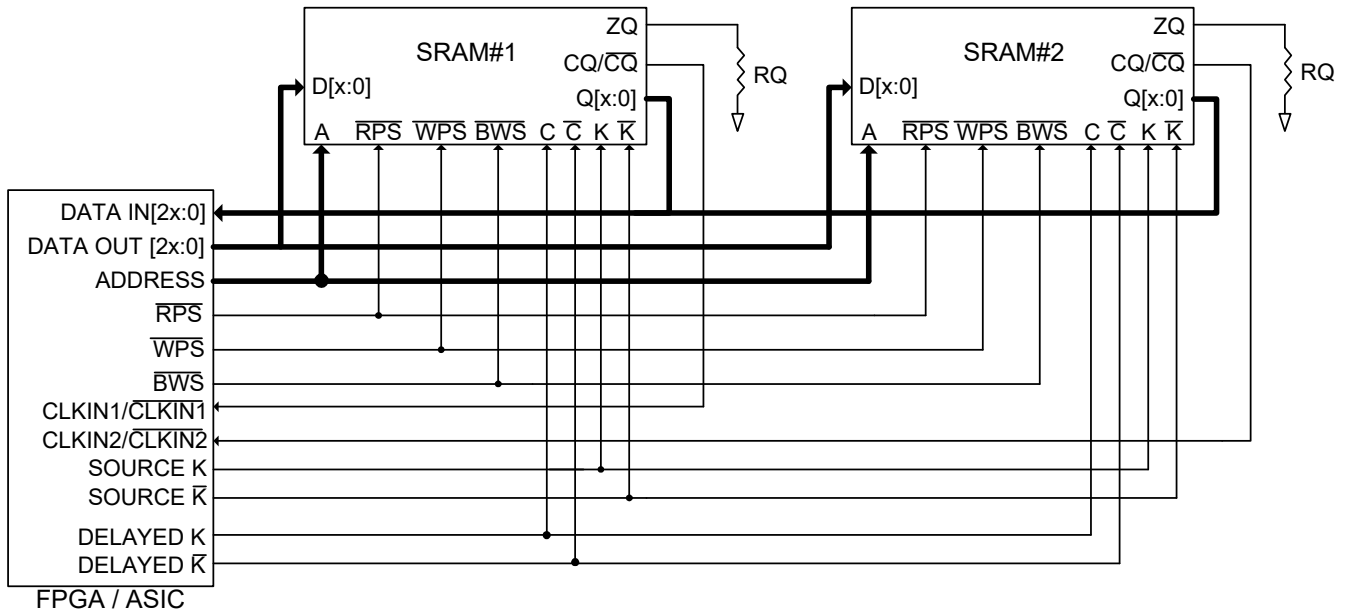



Truth Table

The truth table for CY7C1525KV18, CY7C1512KV18, and CY7C1514KV18 follow. [2, 3, 4, 5, 6, 7]

| Operation | K | $\overline{\text{RPS}}$ | $\overline{\text{WPS}}$ | DQ | DQ |
|---|---------|-------------------------|-------------------------|---|---|
| Write cycle: Load address on the rising edge of $\overline{\text{K}}$; input write data on K and $\overline{\text{K}}$ rising edges. | L-H | X | L | D(A + 0) at K(t) \uparrow | D(A + 1) at $\overline{\text{K}}(t)$ \uparrow |
| Read cycle: Load address on the rising edge of K; wait one and a half cycle; read data on $\overline{\text{C}}$ and C rising edges. | L-H | L | X | Q(A + 0) at $\overline{\text{C}}(t + 1)$ \uparrow | Q(A + 1) at C(t + 2) \uparrow |
| NOP: No operation | L-H | H | H | D = X Q = High Z | D = X Q = High Z |
| Standby: Clock stopped | Stopped | X | X | Previous State | Previous State |

Write Cycle Descriptions

The write cycle description table for CY7C1512KV18 follow. [2, 8]

| $\overline{\text{BWS}}_0$ | $\overline{\text{BWS}}_1$ | K | $\overline{\text{K}}$ | Comments |
|---------------------------|---------------------------|-----|-----------------------|--|
| L | L | L-H | - | During the data portion of a write sequence: CY7C1512KV18 – both bytes ($D_{[17:0]}$) are written into the device. |
| L | L | - | L-H | During the data portion of a write sequence: CY7C1512KV18 – both bytes ($D_{[17:0]}$) are written into the device. |
| L | H | L-H | - | During the data portion of a write sequence: CY7C1512KV18 – only the lower byte ($D_{[8:0]}$) is written into the device, $D_{[17:9]}$ remains unaltered. |
| L | H | - | L-H | During the data portion of a write sequence: CY7C1512KV18 – only the lower byte ($D_{[8:0]}$) is written into the device, $D_{[17:9]}$ remains unaltered. |
| H | L | L-H | - | During the data portion of a write sequence: CY7C1512KV18 – only the upper byte ($D_{[17:9]}$) is written into the device, $D_{[8:0]}$ remains unaltered. |
| H | L | - | L-H | During the data portion of a write sequence: CY7C1512KV18 – only the upper byte ($D_{[17:9]}$) is written into the device, $D_{[8:0]}$ remains unaltered. |
| H | H | L-H | - | No data is written into the devices during this portion of a write operation. |
| H | H | - | L-H | No data is written into the devices during this portion of a write operation. |

Notes

- X = "Don't Care," H = Logic HIGH, L = Logic LOW, \uparrow represents rising edge.
- Device powers up deselected with the outputs in a tristate condition.
- "A" represents address location latched by the devices when transaction was initiated. A + 0, A + 1 represents the internal address sequence in the burst.
- "t" represents the cycle at which a read/write operation is started. t + 1, and t + 2 are the first, and second clock cycles respectively succeeding the "t" clock cycle.
- Data inputs are registered at K and $\overline{\text{K}}$ rising edges. Data outputs are delivered on C and $\overline{\text{C}}$ rising edges, except when in single clock mode.
- Ensure that when the clock is stopped K = $\overline{\text{K}}$ and C = $\overline{\text{C}}$ = HIGH. This is not essential, but permits most rapid restart by overcoming transmission line charging symmetrically.
- Is based on a write cycle that was initiated in accordance with the Truth Table. $\overline{\text{BWS}}_0$, $\overline{\text{BWS}}_1$, $\overline{\text{BWS}}_2$, and $\overline{\text{BWS}}_3$ can be altered on different portions of a write cycle, as long as the setup and hold requirements are achieved.



Write Cycle Descriptions

The write cycle description table for CY7C1525KV18 follow. [9, 10]

| \overline{BWS}_0 | K | \overline{K} | Comments |
|--------------------|-----|----------------|--|
| L | L-H | - | During the data portion of a write sequence, the single byte ($D_{[8:0]}$) is written into the device. |
| L | - | L-H | During the data portion of a write sequence, the single byte ($D_{[8:0]}$) is written into the device. |
| H | L-H | - | No data is written into the device during this portion of a write operation. |
| H | - | L-H | No data is written into the device during this portion of a write operation. |

Write Cycle Descriptions

The write cycle description table for CY7C1514KV18 follow. [9, 10]

| \overline{BWS}_0 | \overline{BWS}_1 | \overline{BWS}_2 | \overline{BWS}_3 | K | \overline{K} | Comments |
|--------------------|--------------------|--------------------|--------------------|-----|----------------|--|
| L | L | L | L | L-H | - | During the data portion of a write sequence, all four bytes ($D_{[35:0]}$) are written into the device. |
| L | L | L | L | - | L-H | During the data portion of a write sequence, all four bytes ($D_{[35:0]}$) are written into the device. |
| L | H | H | H | L-H | - | During the data portion of a write sequence, only the lower byte ($D_{[8:0]}$) is written into the device. $D_{[35:9]}$ remains unaltered. |
| L | H | H | H | - | L-H | During the data portion of a write sequence, only the lower byte ($D_{[8:0]}$) is written into the device. $D_{[35:9]}$ remains unaltered. |
| H | L | H | H | L-H | - | During the data portion of a write sequence, only the byte ($D_{[17:9]}$) is written into the device. $D_{[8:0]}$ and $D_{[35:18]}$ remains unaltered. |
| H | L | H | H | - | L-H | During the data portion of a write sequence, only the byte ($D_{[17:9]}$) is written into the device. $D_{[8:0]}$ and $D_{[35:18]}$ remains unaltered. |
| H | H | L | H | L-H | - | During the data portion of a write sequence, only the byte ($D_{[26:18]}$) is written into the device. $D_{[17:0]}$ and $D_{[35:27]}$ remains unaltered. |
| H | H | L | H | - | L-H | During the data portion of a write sequence, only the byte ($D_{[26:18]}$) is written into the device. $D_{[17:0]}$ and $D_{[35:27]}$ remains unaltered. |
| H | H | H | L | L-H | - | During the data portion of a write sequence, only the byte ($D_{[35:27]}$) is written into the device. $D_{[26:0]}$ remains unaltered. |
| H | H | H | L | - | L-H | During the data portion of a write sequence, only the byte ($D_{[35:27]}$) is written into the device. $D_{[26:0]}$ remains unaltered. |
| H | H | H | H | L-H | - | No data is written into the device during this portion of a write operation. |
| H | H | H | H | - | L-H | No data is written into the device during this portion of a write operation. |

Notes

9. X = "Don't Care," H = Logic HIGH, L = Logic LOW, \uparrow represents rising edge.

10. Is based on a write cycle that was initiated in accordance with the Truth Table on page 11. \overline{BWS}_0 , \overline{BWS}_1 , \overline{BWS}_2 , and \overline{BWS}_3 can be altered on different portions of a write cycle, as long as the setup and hold requirements are achieved.



IEEE 1149.1 Serial Boundary Scan (JTAG)

These SRAMs incorporate a serial boundary scan Test Access Port (TAP) in the FBGA package. This part is fully compliant with IEEE Standard #1149.1-2001. The TAP operates using JEDEC standard 1.8 V I/O logic levels.

Disabling the JTAG Feature

It is possible to operate the SRAM without using the JTAG feature. To disable the TAP controller, TCK must be tied LOW (V_{SS}) to prevent clocking of the device. TDI and TMS are internally pulled up and may be unconnected. They may alternatively be connected to V_{DD} through a pull up resistor. TDO must be left unconnected. Upon power up, the device comes up in a reset state, which does not interfere with the operation of the device.

Test Access Port

Test Clock

The test clock is used only with the TAP controller. All inputs are captured on the rising edge of TCK. All outputs are driven from the falling edge of TCK.

Test Mode Select (TMS)

The TMS input is used to give commands to the TAP controller and is sampled on the rising edge of TCK. This pin may be left unconnected if the TAP is not used. The pin is pulled up internally, resulting in a logic HIGH level.

Test Data-In (TDI)

The TDI pin is used to serially input information into the registers and can be connected to the input of any of the registers. The register between TDI and TDO is chosen by the instruction that is loaded into the TAP instruction register. For information about loading the instruction register, see the [TAP Controller State Diagram on page 15](#). TDI is internally pulled up and can be unconnected if the TAP is unused in an application. TDI is connected to the most significant bit (MSB) on any register.

Test Data-Out (TDO)

The TDO output pin is used to serially clock data out from the registers. The output is active, depending upon the current state of the TAP state machine (see [Instruction Codes on page 19](#)). The output changes on the falling edge of TCK. TDO is connected to the least significant bit (LSB) of any register.

Performing a TAP Reset

A Reset is performed by forcing TMS HIGH (V_{DD}) for five rising edges of TCK. This Reset does not affect the operation of the SRAM and is performed when the SRAM is operating. At power up, the TAP is reset internally to ensure that TDO comes up in a high Z state.

TAP Registers

Registers are connected between the TDI and TDO pins to scan the data in and out of the SRAM test circuitry. Only one register can be selected at a time through the instruction registers. Data is serially loaded into the TDI pin on the rising edge of TCK. Data is output on the TDO pin on the falling edge of TCK.

Instruction Register

Three-bit instructions are serially loaded into the instruction register. This register is loaded when it is placed between the TDI and TDO pins, as shown in [TAP Controller Block Diagram on page 16](#). Upon power up, the instruction register is loaded with the IDCODE instruction. It is also loaded with the IDCODE instruction if the controller is placed in a reset state, as described in the previous section.

When the TAP controller is in the Capture-IR state, the two least significant bits are loaded with a binary "01" pattern to enable fault isolation of the board level serial test path.

Bypass Register

To save time when serially shifting data through registers, it is sometimes advantageous to skip certain chips. The bypass register is a single-bit register that can be placed between TDI and TDO pins. This enables shifting of data through the SRAM with minimal delay. The bypass register is set LOW (V_{SS}) when the BYPASS instruction is executed.

Boundary Scan Register

The boundary scan register is connected to all of the input and output pins on the SRAM. Several No Connect (NC) pins are also included in the scan register to reserve pins for higher density devices.

The boundary scan register is loaded with the contents of the RAM input and output ring when the TAP controller is in the Capture-DR state and is then placed between the TDI and TDO pins when the controller is moved to the Shift-DR state. The EXTEST, SAMPLE/PRELOAD, and SAMPLE Z instructions are used to capture the contents of the input and output ring.

The [Boundary Scan Order on page 20](#) shows the order in which the bits are connected. Each bit corresponds to one of the bumps on the SRAM package. The MSB of the register is connected to TDI, and the LSB is connected to TDO.

Identification (ID) Register

The ID register is loaded with a vendor-specific, 32-bit code during the Capture-DR state when the IDCODE command is loaded in the instruction register. The IDCODE is hardwired into the SRAM and can be shifted out when the TAP controller is in the Shift-DR state. The ID register has a vendor code and other information described in [Identification Register Definitions on page 19](#).

TAP Instruction Set

Eight different instructions are possible with the three-bit instruction register. All combinations are listed in [Instruction Codes on page 19](#). Three of these instructions are listed as RESERVED and must not be used. The other five instructions are described in this section in detail.

Instructions are loaded into the TAP controller during the Shift-IR state when the instruction register is placed between TDI and TDO. During this state, instructions are shifted through the instruction register through the TDI and TDO pins. To execute the instruction after it is shifted in, the TAP controller must be moved into the Update-IR state.



IDCODE

The IDCODE instruction loads a vendor-specific, 32-bit code into the instruction register. It also places the instruction register between the TDI and TDO pins and shifts the IDCODE out of the device when the TAP controller enters the Shift-DR state. The IDCODE instruction is loaded into the instruction register at power up or whenever the TAP controller is supplied a Test-Logic-Reset state.

SAMPLE Z

The SAMPLE Z instruction connects the boundary scan register between the TDI and TDO pins when the TAP controller is in a Shift-DR state. The SAMPLE Z command puts the output bus into a High Z state until the next command is supplied during the Update IR state.

SAMPLE/PRELOAD

SAMPLE/PRELOAD is a 1149.1 mandatory instruction. When the SAMPLE/PRELOAD instructions are loaded into the instruction register and the TAP controller is in the Capture-DR state, a snapshot of data on the input and output pins is captured in the boundary scan register.

The TAP controller clock can only operate at a frequency up to 20 MHz, while the SRAM clock operates more than an order of magnitude faster. Because there is a large difference in the clock frequencies, it is possible that during the Capture-DR state, an input or output undergoes a transition. The TAP may then try to capture a signal while in transition (metastable state). This does not harm the device, but there is no guarantee as to the value that is captured. Repeatable results may not be possible.

To guarantee that the boundary scan register captures the correct value of a signal, the SRAM signal must be stabilized long enough to meet the TAP controller's capture setup plus hold times (t_{CS} and t_{CH}). The SRAM clock input might not be captured correctly if there is no way in a design to stop (or slow) the clock during a SAMPLE/PRELOAD instruction. If this is an issue, it is still possible to capture all other signals and simply ignore the value of the CK and CK captured in the boundary scan register.

After the data is captured, it is possible to shift out the data by putting the TAP into the Shift-DR state. This places the boundary scan register between the TDI and TDO pins.

PRELOAD places an initial data pattern at the latched parallel outputs of the boundary scan register cells before the selection of another boundary scan test operation.

The shifting of data for the SAMPLE and PRELOAD phases can occur concurrently when required, that is, while the data captured is shifted out, the preloaded data can be shifted in.

BYPASS

When the BYPASS instruction is loaded in the instruction register and the TAP is placed in a Shift-DR state, the bypass register is placed between the TDI and TDO pins. The advantage of the BYPASS instruction is that it shortens the boundary scan path when multiple devices are connected together on a board.

EXTEST

The EXTEST instruction drives the preloaded data out through the system output pins. This instruction also connects the boundary scan register for serial access between the TDI and TDO in the Shift-DR controller state.

EXTEST OUTPUT BUS TRISTATE

IEEE Standard 1149.1 mandates that the TAP controller be able to put the output bus into a tristate mode.

The boundary scan register has a special bit located at bit #108. When this scan cell, called the "extest output bus tristate," is latched into the preload register during the Update-DR state in the TAP controller, it directly controls the state of the output (Q-bus) pins, when the EXTEST is entered as the current instruction. When HIGH, it enables the output buffers to drive the output bus. When LOW, this bit places the output bus into a High Z condition.

This bit is set by entering the SAMPLE/PRELOAD or EXTEST command, and then shifting the desired bit into that cell, during the Shift-DR state. During Update-DR, the value loaded into that shift-register cell latches into the preload register. When the EXTEST instruction is entered, this bit directly controls the output Q-bus pins. Note that this bit is pre-set LOW to enable the output when the device is powered up, and also when the TAP controller is in the Test-Logic-Reset state.

Reserved

These instructions are not implemented but are reserved for future use. Do not use these instructions.



TAP Controller State Diagram

The state diagram for the TAP controller follows. [11]

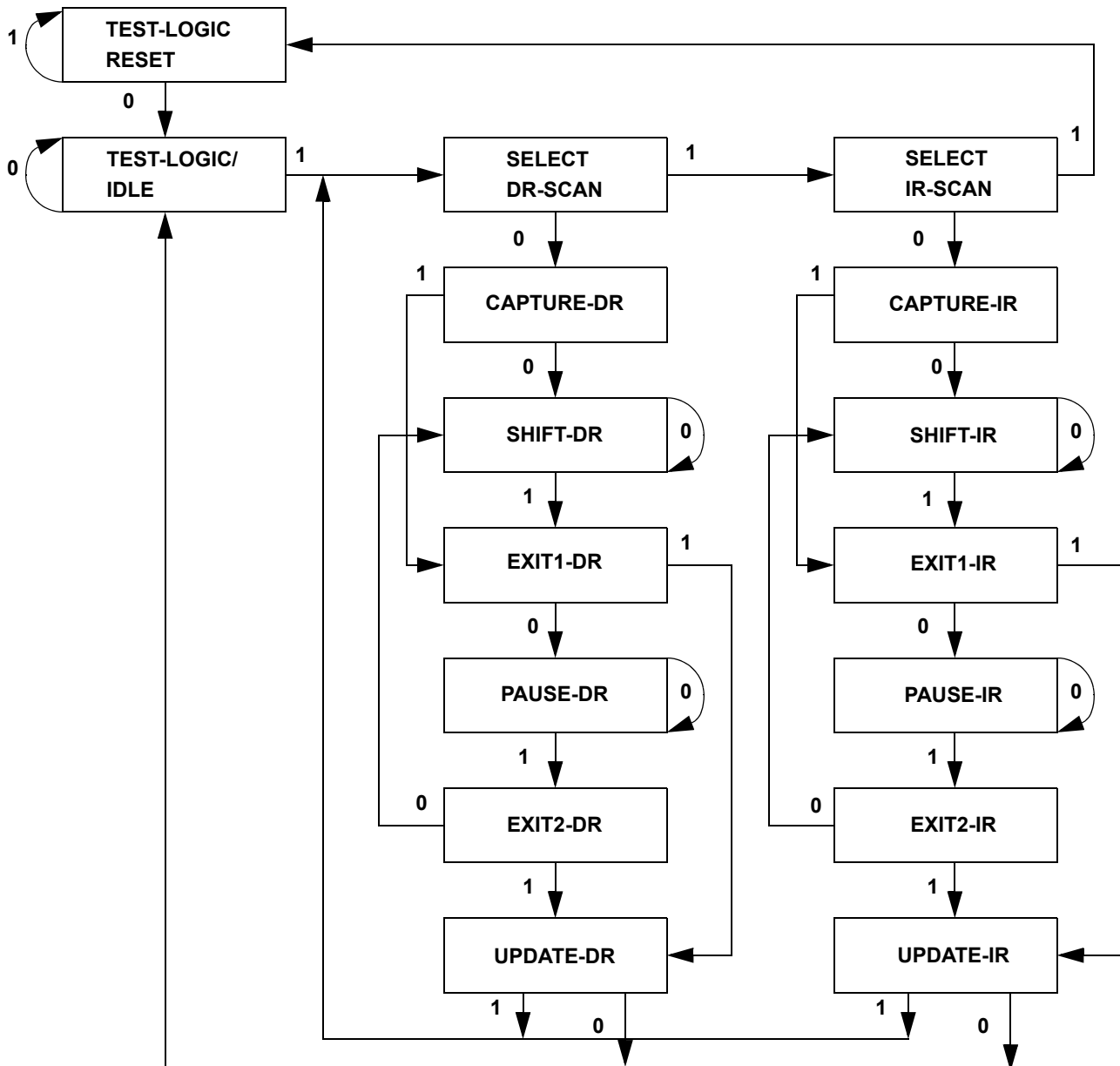

Note
 11. The 0/1 next to each state represents the value at TMS at the rising edge of TCK.



TAP Controller Block Diagram

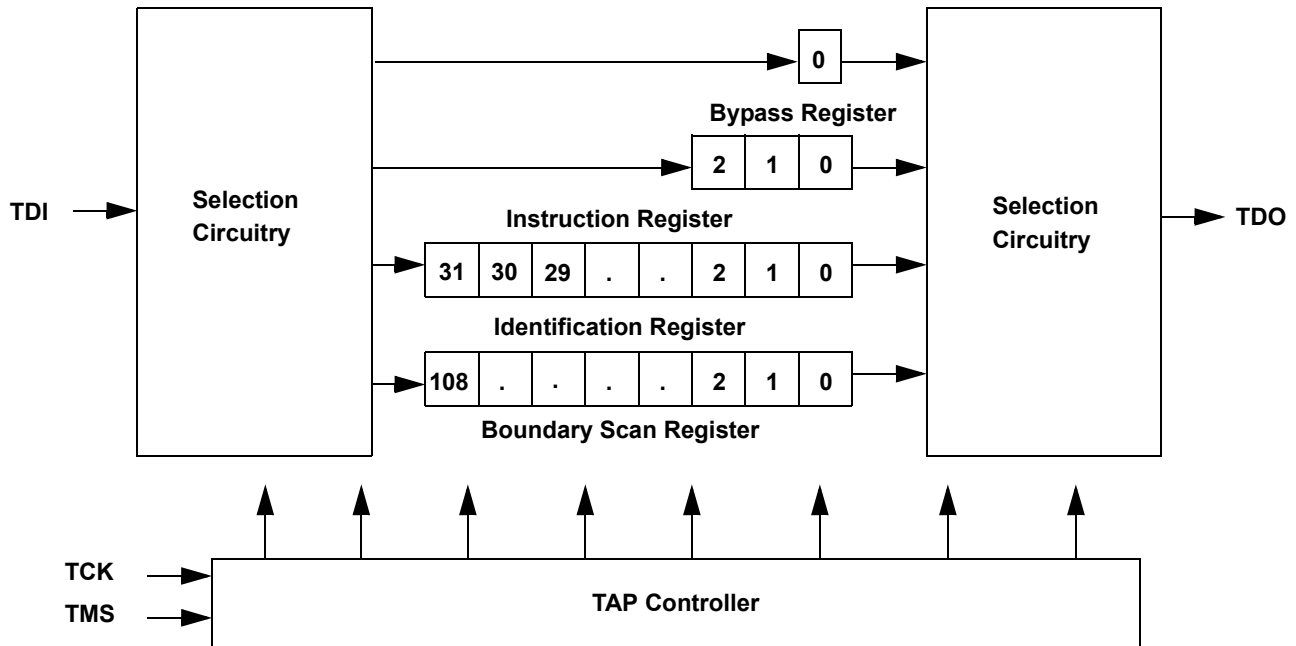

TAP Electrical Characteristics

Over the Operating Range

| Parameter [12, 13, 14] | Description | Test Conditions | Min | Max | Unit |
|------------------------|-------------------------------|--|------------------------|------------------------|------|
| V _{OH1} | Output HIGH voltage | I _{OH} = -2.0 mA | 1.4 | - | V |
| V _{OH2} | Output HIGH voltage | I _{OH} = -100 μA | 1.6 | - | V |
| V _{OL1} | Output LOW voltage | I _{OL} = 2.0 mA | - | 0.4 | V |
| V _{OL2} | Output LOW voltage | I _{OL} = 100 μA | - | 0.2 | V |
| V _{IH} | Input HIGH voltage | | 0.65 × V _{DD} | V _{DD} + 0.3 | V |
| V _{IL} | Input LOW voltage | | -0.3 | 0.35 × V _{DD} | V |
| I _X | Input and output load current | GND ≤ V _I ≤ V _{DD} | -5 | 5 | μA |

Notes

12. These characteristics pertain to the TAP inputs (TMS, TCK, TDI, and TDO). Parallel load levels are specified in the [Electrical Characteristics on page 22](#).
13. Overshoot: V_{IH(AC)} < V_{DDQ} + 0.85 V (Pulse width less than t_{CYC/2}), Undershoot: V_{IL(AC)} > -1.5 V (Pulse width less than t_{CYC/2}).
14. All voltage referenced to Ground.



TAP AC Switching Characteristics

Over the Operating Range

| Parameter ^[15, 16] | Description | Min | Max | Unit |
|-------------------------------|-------------------------------|-----|-----|------|
| t_{TCYC} | TCK clock cycle time | 50 | – | ns |
| t_{TF} | TCK clock frequency | – | 20 | MHz |
| t_{TH} | TCK clock HIGH | 20 | – | ns |
| t_{TL} | TCK clock LOW | 20 | – | ns |
| Setup Times | | | | |
| t_{TMSS} | TMS setup to TCK clock rise | 5 | – | ns |
| t_{TDIS} | TDI setup to TCK clock rise | 5 | – | ns |
| t_{CS} | Capture setup to TCK rise | 5 | – | ns |
| Hold Times | | | | |
| t_{TMSH} | TMS hold after TCK clock rise | 5 | – | ns |
| t_{TDIH} | TDI hold after clock rise | 5 | – | ns |
| t_{CH} | Capture hold after clock rise | 5 | – | ns |
| Output Times | | | | |
| t_{TDOV} | TCK clock LOW to TDO valid | – | 10 | ns |
| t_{TDOX} | TCK clock LOW to TDO invalid | 0 | – | ns |

Notes

15. t_{CS} and t_{CH} refer to the setup and hold time requirements of latching data from the boundary scan register.
 16. Test conditions are specified using the load in TAP AC Test Conditions. $t_R/t_F = 1$ ns.

TAP Timing and Test Conditions

Figure 3 shows the TAP timing and test conditions. [17]

Figure 3. TAP Timing and Test Conditions

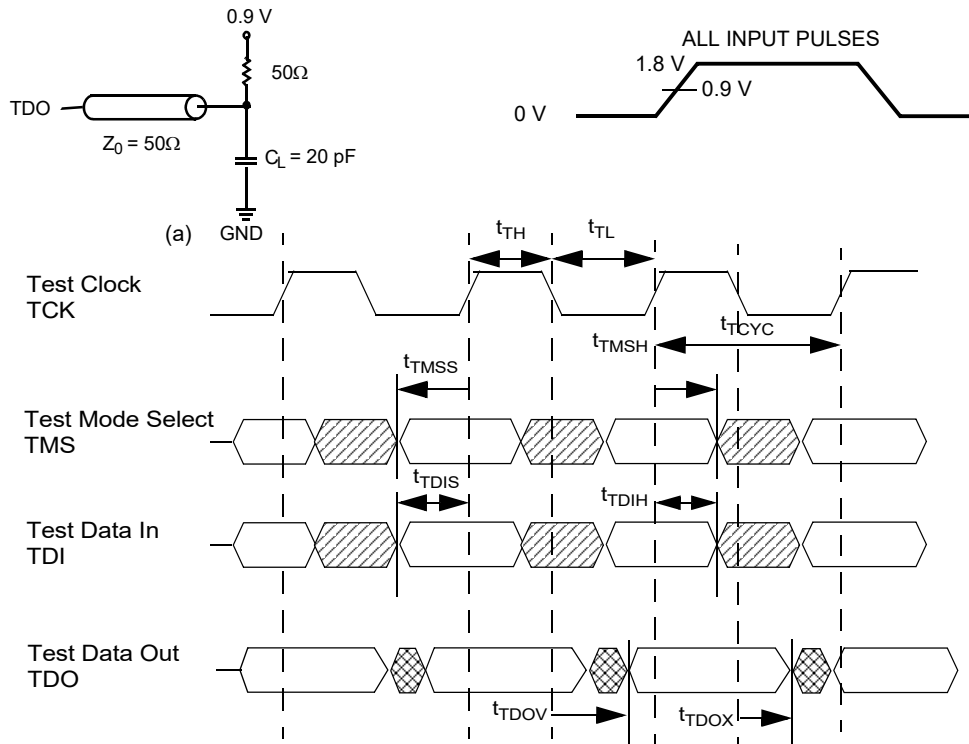

Note

17. Test conditions are specified using the load in TAP AC Test Conditions. $t_R/t_F = 1$ ns.



Identification Register Definitions

| Instruction Field | Value | | | Description |
|---------------------------|-------------------|-------------------|-------------------|--|
| | CY7C1525KV18 | CY7C1512KV18 | CY7C1514KV18 | |
| Revision number (31:29) | 000 | 000 | 000 | Version number. |
| Cypress device ID (28:12) | 11010011010001100 | 11010011010010100 | 11010011010100100 | Defines the type of SRAM. |
| Cypress JEDEC ID (11:1) | 00000110100 | 00000110100 | 00000110100 | Allows unique identification of SRAM vendor. |
| ID register presence (0) | 1 | 1 | 1 | Indicates the presence of an ID register. |

Scan Register Sizes

| Register Name | Bit Size |
|---------------|----------|
| Instruction | 3 |
| Bypass | 1 |
| ID | 32 |
| Boundary Scan | 109 |

Instruction Codes

| Instruction | Code | Description |
|----------------|------|--|
| EXTEST | 000 | Captures the input and output ring contents. |
| IDCODE | 001 | Loads the ID register with the vendor ID code and places the register between TDI and TDO. This operation does not affect SRAM operation. |
| SAMPLE Z | 010 | Captures the input and output contents. Places the boundary scan register between TDI and TDO. Forces all SRAM output drivers to a High-Z state. |
| RESERVED | 011 | Do Not Use: This instruction is reserved for future use. |
| SAMPLE/PRELOAD | 100 | Captures the input and output contents. Places the boundary scan register between TDI and TDO. Does not affect the SRAM operation. |
| RESERVED | 101 | Do Not Use: This instruction is reserved for future use. |
| RESERVED | 110 | Do Not Use: This instruction is reserved for future use. |
| BYPASS | 111 | Places the bypass register between TDI and TDO. This operation does not affect SRAM operation. |



Boundary Scan Order

| Bit # | Bump ID |
|-------|---------|
| 0 | 6R |
| 1 | 6P |
| 2 | 6N |
| 3 | 7P |
| 4 | 7N |
| 5 | 7R |
| 6 | 8R |
| 7 | 8P |
| 8 | 9R |
| 9 | 11P |
| 10 | 10P |
| 11 | 10N |
| 12 | 9P |
| 13 | 10M |
| 14 | 11N |
| 15 | 9M |
| 16 | 9N |
| 17 | 11L |
| 18 | 11M |
| 19 | 9L |
| 20 | 10L |
| 21 | 11K |
| 22 | 10K |
| 23 | 9J |
| 24 | 9K |
| 25 | 10J |
| 26 | 11J |
| 27 | 11H |

| Bit # | Bump ID |
|-------|---------|
| 28 | 10G |
| 29 | 9G |
| 30 | 11F |
| 31 | 11G |
| 32 | 9F |
| 33 | 10F |
| 34 | 11E |
| 35 | 10E |
| 36 | 10D |
| 37 | 9E |
| 38 | 10C |
| 39 | 11D |
| 40 | 9C |
| 41 | 9D |
| 42 | 11B |
| 43 | 11C |
| 44 | 9B |
| 45 | 10B |
| 46 | 11A |
| 47 | 10A |
| 48 | 9A |
| 49 | 8B |
| 50 | 7C |
| 51 | 6C |
| 52 | 8A |
| 53 | 7A |
| 54 | 7B |
| 55 | 6B |

| Bit # | Bump ID |
|-------|---------|
| 56 | 6A |
| 57 | 5B |
| 58 | 5A |
| 59 | 4A |
| 60 | 5C |
| 61 | 4B |
| 62 | 3A |
| 63 | 2A |
| 64 | 1A |
| 65 | 2B |
| 66 | 3B |
| 67 | 1C |
| 68 | 1B |
| 69 | 3D |
| 70 | 3C |
| 71 | 1D |
| 72 | 2C |
| 73 | 3E |
| 74 | 2D |
| 75 | 2E |
| 76 | 1E |
| 77 | 2F |
| 78 | 3F |
| 79 | 1G |
| 80 | 1F |
| 81 | 3G |
| 82 | 2G |
| 83 | 1H |

| Bit # | Bump ID |
|-------|----------|
| 84 | 1J |
| 85 | 2J |
| 86 | 3K |
| 87 | 3J |
| 88 | 2K |
| 89 | 1K |
| 90 | 2L |
| 91 | 3L |
| 92 | 1M |
| 93 | 1L |
| 94 | 3N |
| 95 | 3M |
| 96 | 1N |
| 97 | 2M |
| 98 | 3P |
| 99 | 2N |
| 100 | 2P |
| 101 | 1P |
| 102 | 3R |
| 103 | 4R |
| 104 | 4P |
| 105 | 5P |
| 106 | 5N |
| 107 | 5R |
| 108 | Internal |



Power Up Sequence in QDR II SRAM

QDR II SRAMs must be powered up and initialized in a predefined manner to prevent undefined operations.

Power Up Sequence

- Apply power and drive $\overline{\text{DOFF}}$ either HIGH or LOW (All other inputs can be HIGH or LOW).
 - Apply V_{DD} before V_{DDQ} .
 - Apply V_{DDQ} before V_{REF} or at the same time as V_{REF} .
 - Drive $\overline{\text{DOFF}}$ HIGH.
- Provide stable $\overline{\text{DOFF}}$ (HIGH), power and clock (K, $\overline{\text{K}}$) for 20 μs to lock the PLL.

PLL Constraints

- PLL uses K clock as its synchronizing input. The input must have low phase jitter, which is specified as $t_{\text{KC Var}}$.
- The PLL functions at frequencies down to 120 MHz.
- If the input clock is unstable and the PLL is enabled, then the PLL may lock onto an incorrect frequency, causing unstable SRAM behavior. To avoid this, provide 20 μs of stable clock to relock to the desired clock frequency.

Figure 4. Power Up Waveforms

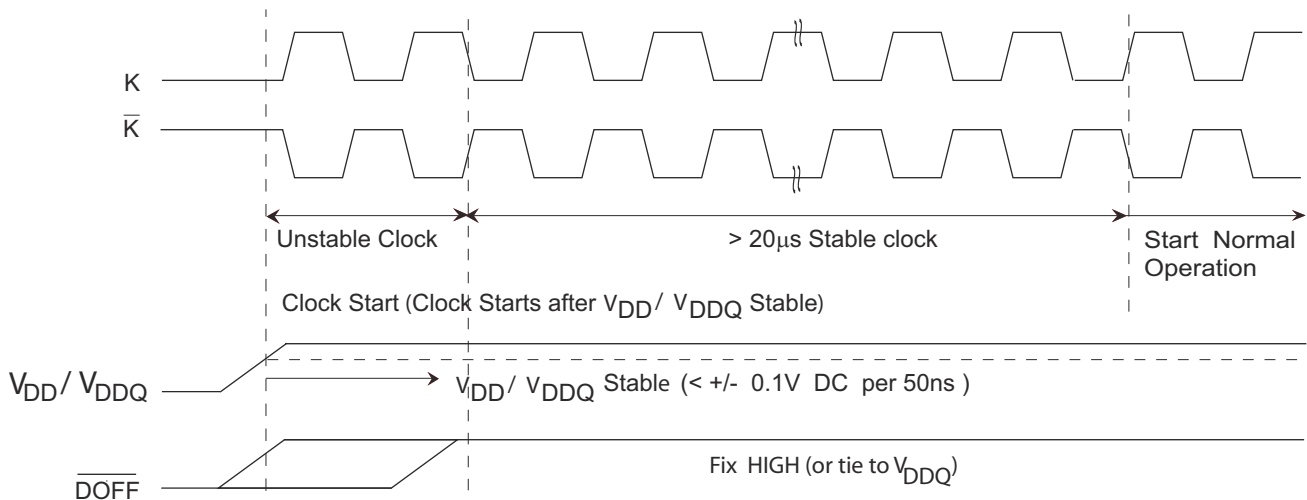



Maximum Ratings

Exceeding maximum ratings may impair the useful life of the device. These user guidelines are not tested.

Storage temperature -65 °C to +150 °C
 Ambient temperature
 with power applied -55 °C to +125 °C
 Supply voltage on V_{DD} relative to GND -0.5 V to +2.9 V
 Supply voltage on V_{DDQ} relative to GND -0.5 V to +V_{DD}
 DC applied to outputs in High Z -0.5 V to V_{DDQ} + 0.5 V
 DC input voltage ^[18] -0.5 V to V_{DD} + 0.5 V
 Current into outputs (LOW) 20 mA
 Static discharge voltage
 (MIL-STD-883, M. 3015) > 2001 V
 Latch up current > 200 mA

Operating Range

| Range | Ambient Temperature (T _A) | V _{DD} ^[19] | V _{DDQ} ^[19] |
|------------|---------------------------------------|---------------------------------|----------------------------------|
| Commercial | 0 °C to +70 °C | 1.8 ± 0.1 V | 1.4 V to V _{DD} |
| Industrial | -40 °C to +85 °C | | |

Neutron Soft Error Immunity

| Parameter | Description | Test Conditions | Typ | Max* | Unit |
|-----------|---------------------------|-----------------|-----|------|---------|
| LSBU | Logical single-bit upsets | 25 °C | 197 | 216 | FIT/Mb |
| LMBU | Logical multi-bit upsets | 25 °C | 0 | 0.01 | FIT/Mb |
| SEL | Single event latch up | 85 °C | 0 | 0.1 | FIT/Dev |

* No LMBU or SEL events occurred during testing; this column represents a statistical χ^2 , 95% confidence limit calculation. For more details refer to Application Note AN54908 "Accelerated Neutron SER Testing and Calculation of Terrestrial Failure Rates".

Electrical Characteristics

Over the Operating Range

DC Electrical Characteristics

Over the Operating Range

| Parameter ^[20] | Description | Test Conditions | Min | Typ | Max | Unit |
|---------------------------|---|---|----------------------------|------|----------------------------|------|
| V _{DD} | Power supply voltage | | 1.7 | 1.8 | 1.9 | V |
| V _{DDQ} | I/O supply voltage | | 1.4 | 1.5 | V _{DD} | V |
| V _{OH} | Output HIGH voltage | Note 21 | V _{DDQ} /2 - 0.12 | - | V _{DDQ} /2 + 0.12 | V |
| V _{OL} | Output LOW voltage | Note 22 | V _{DDQ} /2 - 0.12 | - | V _{DDQ} /2 + 0.12 | V |
| V _{OH(LOW)} | Output HIGH voltage | I _{OH} = -0.1 mA, Nominal Impedance | V _{DDQ} - 0.2 | - | V _{DDQ} | V |
| V _{OL(LOW)} | Output LOW voltage | I _{OL} = 0.1 mA, Nominal Impedance | V _{SS} | - | 0.2 | V |
| V _{IH} | Input HIGH voltage | | V _{REF} + 0.1 | - | V _{DDQ} + 0.3 | V |
| V _{IL} | Input LOW voltage | | -0.3 | - | V _{REF} - 0.1 | V |
| I _X | Input leakage current | GND ≤ V _I ≤ V _{DDQ} | -5 | - | 5 | μA |
| I _{OZ} | Output leakage current | GND ≤ V _I ≤ V _{DDQ} , Output Disabled | -5 | - | 5 | μA |
| V _{REF} | Input reference voltage ^[23] | Typical Value = 0.75 V | 0.68 | 0.75 | 0.95 | V |

Notes

18. Overshoot: V_{IH(AC)} < V_{DDQ} + 0.85 V (Pulse width less than t_{CYC}/2), Undershoot: V_{IL(AC)} > -1.5 V (Pulse width less than t_{CYC}/2).
19. Power up: Assumes a linear ramp from 0 V to V_{DD(min)} within 200 ms. During this time V_{IH} < V_{DD} and V_{DDQ} ≤ V_{DD}.
20. All voltage referenced to Ground.
21. Output are impedance controlled. I_{OH} = -(V_{DDQ}/2)/(RQ/5) for values of 175 Ω ≤ RQ ≤ 350 Ω.
22. Output are impedance controlled. I_{OL} = (V_{DDQ}/2)/(RQ/5) for values of 175 Ω ≤ RQ ≤ 350 Ω.
23. V_{REF(min)} = 0.68 V or 0.46 V_{DDQ}, whichever is larger, V_{REF(max)} = 0.95 V or 0.54 V_{DDQ}, whichever is smaller.



Electrical Characteristics (continued)

Over the Operating Range

DC Electrical Characteristics (continued)

Over the Operating Range

| Parameter ^[20] | Description | Test Conditions | Min | Typ | Max | Unit | | | | | |
|---------------------------------|----------------------------------|--|------------------|------------------------------|---|---------|--------|----|---|-----|----|
| I _{DD} ^[24] | V _{DD} operating supply | V _{DD} = Max, I _{OUT} = 0 mA, f = f _{MAX} = 1/t _{CYC} | 350 MHz | (× 18) | – | – | 840 | mA | | | |
| | | | 333 MHz | (× 9) | – | – | 790 | mA | | | |
| | | | | (× 18) | – | – | 810 | | | | |
| | | | | (× 36) | – | – | 990 | | | | |
| | | | 300 MHz | (× 9) | – | – | 730 | mA | | | |
| | | | | (× 18) | – | – | 750 | | | | |
| | | | | (× 36) | – | – | 910 | | | | |
| | | | 250 MHz | (× 9) | – | – | 640 | mA | | | |
| | | | | (× 18) | – | – | 650 | | | | |
| | | | | (× 36) | – | – | 790 | | | | |
| | | | I _{SB1} | Automatic power down current | Max V _{DD} , Both Ports Deselected, V _{IN} ≥ V _{IH} or V _{IN} ≤ V _{IL} , f = f _{MAX} = 1/t _{CYC} , Inputs Static | 350 MHz | (× 18) | – | – | 295 | mA |
| | | | | | | 333 MHz | (× 9) | – | – | 290 | mA |
| (× 18) | – | – | | | | | 290 | | | | |
| (× 36) | – | – | | | | | 290 | | | | |
| 300 MHz | (× 9) | – | | | | – | 280 | mA | | | |
| | (× 18) | – | | | | – | 280 | | | | |
| | (× 36) | – | | | | – | 280 | | | | |
| 250 MHz | (× 9) | – | | | | – | 270 | mA | | | |
| | (× 18) | – | | | | – | 270 | | | | |
| | (× 36) | – | | | | – | 270 | | | | |

Note

24. The operation current is calculated with 50% read cycle and 50% write cycle.



AC Electrical Characteristics

Over the Operating Range

| Parameter ^[25] | Description | Test Conditions | Min | Typ | Max | Unit |
|---------------------------|--------------------|-----------------|------------------------|-----|------------------------|------|
| V _{IH} | Input HIGH voltage | | V _{REF} + 0.2 | – | – | V |
| V _{IL} | Input LOW voltage | | – | – | V _{REF} – 0.2 | V |

Capacitance

| Parameter ^[26] | Description | Test Conditions | Max | Unit |
|---------------------------|--------------------|--|-----|------|
| C _{IN} | Input capacitance | T _A = 25 °C, f = 1 MHz, V _{DD} = 1.8 V, V _{DDQ} = 1.5 V | 4 | pF |
| C _O | Output capacitance | | 4 | pF |

Thermal Resistance

| Parameter ^[26] | Description | Test Conditions | 165-ball FBGA Package | Unit |
|---------------------------|--|--|-----------------------|------|
| Θ _{JA} (0 m/s) | Thermal resistance (junction to ambient) | Socketed on a 170 × 220 × 2.35 mm, eight-layer printed circuit board | 14.43 | °C/W |
| Θ _{JA} (1 m/s) | | | 13.40 | °C/W |
| Θ _{JA} (3 m/s) | | | 12.66 | °C/W |
| Θ _{JB} | Thermal resistance (junction to board) | | 11.38 | °C/W |
| Θ _{JC} | Thermal resistance (junction to case) | | 3.30 | °C/W |

AC Test Loads and Waveforms

Figure 5. AC Test Loads and Waveforms

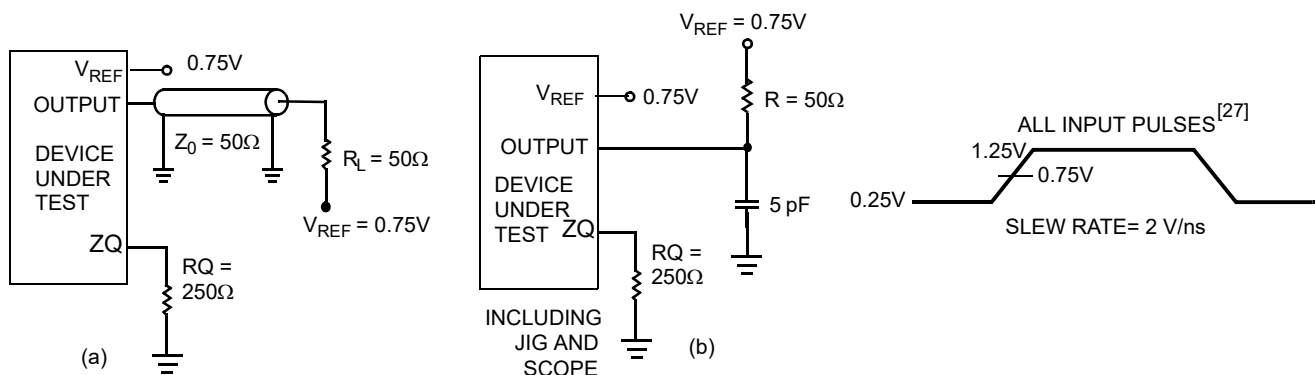

Notes

25. Overshoot: V_{IH(AC)} < V_{DDQ} + 0.85 V (Pulse width less than t_{CYC}/2), Undershoot: V_{IL(AC)} > –1.5 V (Pulse width less than t_{CYC}/2).

26. Tested initially and after any design or process change that may affect these parameters.

27. Unless otherwise noted, test conditions are based on signal transition time of 2 V/ns, timing reference levels of 0.75 V, V_{ref} = 0.75 V, R_Q = 250 Ω, V_{DDQ} = 1.5 V, input pulse levels of 0.25 V to 1.25 V, and output loading of the specified I_{OL}/I_{OH} and load capacitance shown in (a) of Figure 5.



Switching Characteristics

Over the Operating Range

| Parameters ^[28, 29] | | Description | 350 MHz | | 333 MHz | | 300 MHz | | 250 MHz | | Unit |
|--------------------------------------|--------------------------------------|--|---------|------|---------|------|---------|------|---------|-----|------|
| Cypress Parameter | Consortium Parameter | | Min | Max | Min | Max | Min | Max | Min | Max | |
| t _{POWER} | | V _{DD} (typical) to the first access ^[30] | 1 | – | 1 | – | 1 | – | 1 | – | ms |
| t _{CYC} | t _{KHKH} | K clock and C clock cycle time | 2.85 | 8.4 | 3.0 | 8.4 | 3.3 | 8.4 | 4.0 | 8.4 | ns |
| t _{KH} | t _{KHKL} | Input clock (K/K; C/C) HIGH | 1.14 | – | 1.20 | – | 1.32 | – | 1.6 | – | ns |
| t _{KL} | t _{KLKH} | Input clock (K/K; C/C) LOW | 1.14 | – | 1.20 | – | 1.32 | – | 1.6 | – | ns |
| t _{KH\bar{K}H} | t _{KH\bar{K}H} | K clock rise to \bar{K} clock rise and C to \bar{C} rise (rising edge to rising edge) | 1.28 | – | 1.35 | – | 1.49 | – | 1.8 | – | ns |
| t _{KHCH} | t _{KHCH} | K/ \bar{K} clock rise to C/ \bar{C} clock rise (rising edge to rising edge) | 0 | 1.22 | 0 | 1.30 | 0 | 1.45 | 0 | 1.8 | ns |
| Setup Times | | | | | | | | | | | |
| t _{SA} | t _{AVKH} | Address setup to K clock rise | 0.3 | – | 0.3 | – | 0.3 | – | 0.35 | – | ns |
| t _{SC} | t _{IVKH} | Control setup to K clock rise (RPS, WPS) | 0.3 | – | 0.3 | – | 0.3 | – | 0.35 | – | ns |
| t _{SCDDR} | t _{IVKH} | DDR control setup to clock (K/ \bar{K}) Rise (BWS ₀ , BWS ₁ , BWS ₂ , BWS ₃) | 0.3 | – | 0.3 | – | 0.3 | – | 0.35 | – | ns |
| t _{SD} | t _{DVKH} | D _[X:0] setup to clock (K/ \bar{K}) rise | 0.3 | – | 0.3 | – | 0.3 | – | 0.35 | – | ns |
| Hold Times | | | | | | | | | | | |
| t _{HA} | t _{KHAX} | Address hold after K clock rise | 0.3 | – | 0.3 | – | 0.3 | – | 0.35 | – | ns |
| t _{HC} | t _{KHIX} | Control hold after K clock rise (RPS, WPS) | 0.3 | – | 0.3 | – | 0.3 | – | 0.35 | – | ns |
| t _{HCDDR} | t _{KHIX} | DDR control hold after clock (K/ \bar{K}) rise (BWS ₀ , BWS ₁ , BWS ₂ , BWS ₃) | 0.3 | – | 0.3 | – | 0.3 | – | 0.35 | – | ns |
| t _{HD} | t _{KHDX} | D _[X:0] hold after clock (K/ \bar{K}) rise | 0.3 | – | 0.3 | – | 0.3 | – | 0.35 | – | ns |

Notes

28. Unless otherwise noted, test conditions are based on signal transition time of 2 V/ns, timing reference levels of 0.75 V, V_{ref} = 0.75 V, R_Q = 250 Ω, V_{DDQ} = 1.5 V, input pulse levels of 0.25 V to 1.25 V, and output loading of the specified I_{OL}/I_{OH} and load capacitance shown in (a) of Figure 5 on page 24.

29. When a part with a maximum frequency above 167 MHz is operating at a lower clock frequency, it requires the input timings of the frequency range in which it is operated and outputs data with the output timings of that frequency range.

30. This part has a voltage regulator internally; t_{POWER} is the time that the power must be supplied above V_{DD(minimum)} initially before initiating a read or write operation.



Switching Characteristics (continued)

Over the Operating Range

| Parameters ^[28, 29] | | Description | 350 MHz | | 333 MHz | | 300 MHz | | 250 MHz | | Unit |
|--|--|---|---------|------|---------|------|---------|------|---------|------|------|
| Cypress Parameter | Consortium Parameter | | Min | Max | Min | Max | Min | Max | Min | Max | |
| Output Times | | | | | | | | | | | |
| t _{CO} | t _{CHQV} | C/ \bar{C} clock rise (or K/ \bar{K} in single clock mode) to data valid | – | 0.45 | – | 0.45 | – | 0.45 | – | 0.45 | ns |
| t _{DOH} | t _{CHQX} | Data output hold after output C/ \bar{C} clock rise (active to active) | –0.45 | – | –0.45 | – | –0.45 | – | –0.45 | – | ns |
| t _{CCQO} | t _{CHCQV} | C/ \bar{C} clock rise to echo clock valid | – | 0.45 | – | 0.45 | – | 0.45 | – | 0.45 | ns |
| t _{CQOH} | t _{CHCQX} | Echo clock hold after C/ \bar{C} clock rise | –0.45 | – | –0.45 | – | –0.45 | – | –0.45 | – | ns |
| t _{CQD} | t _{CQHQV} | Echo clock high to data valid | – | 0.25 | – | 0.25 | – | 0.27 | – | 0.30 | ns |
| t _{CQDOH} | t _{CQHQX} | Echo clock high to data invalid | –0.25 | – | –0.25 | – | –0.27 | – | –0.30 | – | ns |
| t _{CQH} | t _{CQHCQL} | Output clock (CQ/ \bar{CQ}) HIGH ^[31] | 1.18 | – | 1.25 | – | 1.40 | – | 1.75 | – | ns |
| t _{CQH\bar{CQ}H} | t _{CQH\bar{CQ}H} | CQ clock rise to \bar{CQ} clock rise (rising edge to rising edge) ^[31] | 1.18 | – | 1.25 | – | 1.40 | – | 1.75 | – | ns |
| t _{CHZ} | t _{CHQZ} | Clock (C/ \bar{C}) rise to High Z (active to high Z) ^[32, 33] | – | 0.45 | – | 0.45 | – | 0.45 | – | 0.45 | ns |
| t _{CLZ} | t _{CHQX1} | Clock (C/ \bar{C}) rise to low Z ^[32, 33] | –0.45 | – | –0.45 | – | –0.45 | – | –0.45 | – | ns |
| PLL Timing | | | | | | | | | | | |
| t _{KC Var} | t _{KC Var} | Clock phase jitter | – | 0.20 | – | 0.20 | – | 0.20 | – | 0.20 | ns |
| t _{KC lock} | t _{KC lock} | PLL lock time (K, C) ^[34] | 20 | – | 20 | – | 20 | – | 20 | – | μs |
| t _{KC Reset} | t _{KC Reset} | K static to PLL reset | 30 | – | 30 | – | 30 | – | 30 | – | ns |

Notes

31. These parameters are extrapolated from the input timing parameters (t_{CYC}/2 – 250 ps, where 250 ps is the internal jitter). These parameters are only guaranteed by design and are not tested in production.

32. t_{CHZ}, t_{CLZ}, are specified with a load capacitance of 5 pF as in part (b) of Figure 5 on page 24. Transition is measured ± 100 mV from steady state voltage.

33. At any voltage and temperature t_{CHZ} is less than t_{CLZ} and t_{CHZ} less than t_{CO}.

34. For frequencies 300 MHz or below, the Cypress QDR II devices surpass the QDR consortium specification for PLL lock time (t_{KC lock}) of 20 μs (min. spec.) and will lock after 1024 clock cycles (min. spec.), after a stable clock is presented, per the previous 90 nm version.



Switching Waveforms

Read/Write/Deselect Sequence

Figure 6. Waveform for 1.5 Cycle Read Latency [35, 36, 37]

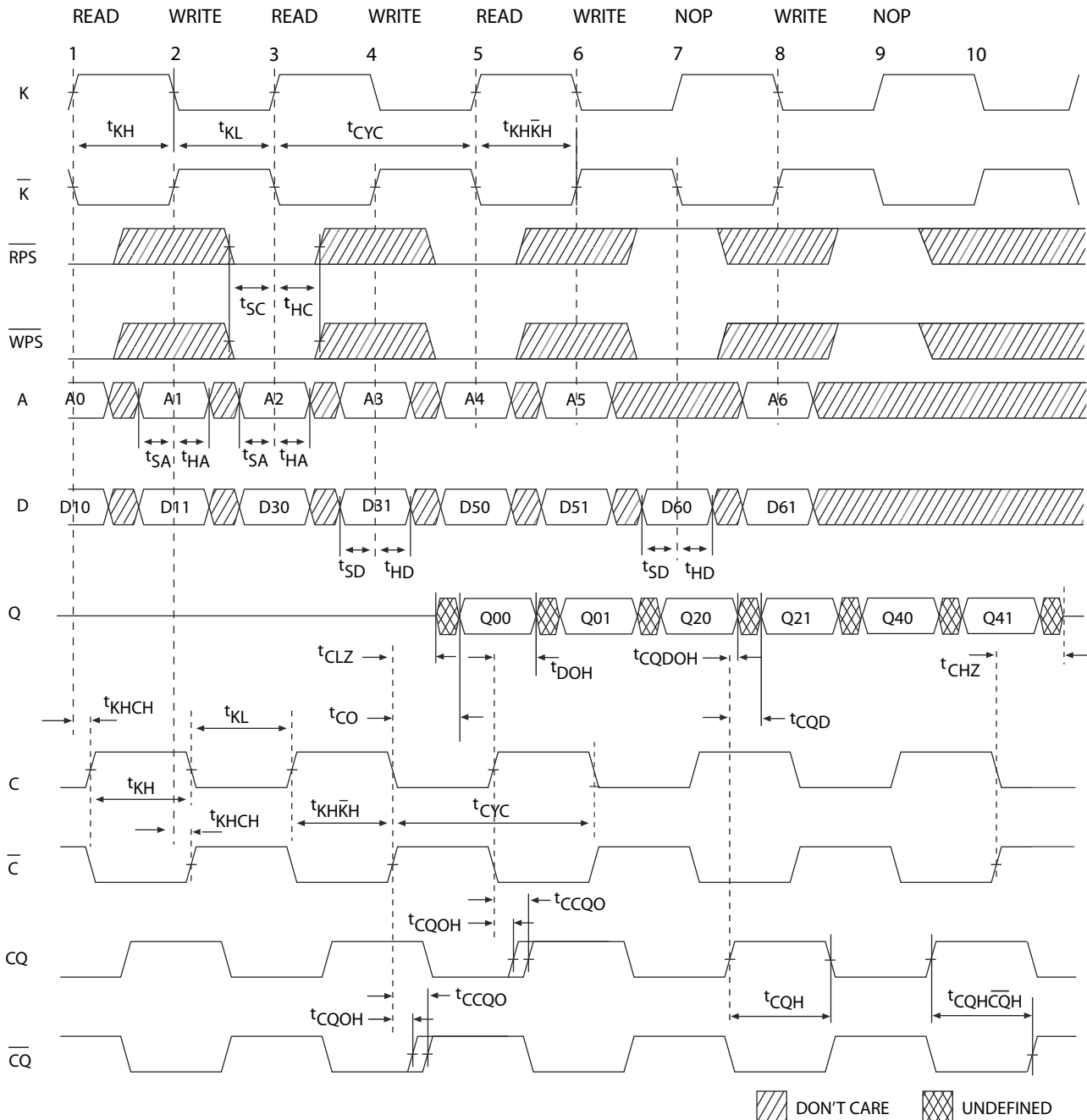

Notes

35. Q00 refers to output from address A0. Q01 refers to output from the next internal burst address following A0, that is, A0 + 1.

36. Outputs are disabled (High Z) one clock cycle after a NOP.

37. In this example, if address A0 = A1, then data Q00 = D10 and Q01 = D11. Write data is forwarded immediately as read results. This note applies to the whole diagram.



Ordering Information

The following table contains only the parts that are currently available. If you do not see what you are looking for, contact your local sales representative. For more information, visit the Cypress website at www.cypress.com and refer to the product summary page at <http://www.cypress.com/products>

Cypress maintains a worldwide network of offices, solution centers, manufacturer's representatives and distributors. To find the office closest to you, visit us at <http://www.cypress.com/go/datasheet/offices>.

| Speed (MHz) | Ordering Code | Package Diagram | Package Type | Operating Range | |
|----------------------|----------------------|----------------------|--|--|------------|
| 333 | CY7C1525KV18-333BZXC | 51-85180 | 165-ball FBGA (13 × 15 × 1.4 mm) Pb-free | Commercial | |
| | CY7C1512KV18-333BZXC | | | | |
| | CY7C1514KV18-333BZXC | | | | |
| | 333 | CY7C1512KV18-333BZI | 51-85180 | 165-ball FBGA (13 × 15 × 1.4 mm) | Industrial |
| | | CY7C1514KV18-333BZI | | | |
| | 300 | CY7C1512KV18-333BZXI | 51-85180 | 165-ball FBGA (13 × 15 × 1.4 mm) Pb-free | Commercial |
| | | CY7C1514KV18-333BZXI | | | |
| CY7C1525KV18-300BZC | | 51-85180 | 165-ball FBGA (13 × 15 × 1.4 mm) | | |
| CY7C1512KV18-300BZC | | 51-85180 | 165-ball FBGA (13 × 15 × 1.4 mm) Pb-free | | |
| CY7C1512KV18-300BZXI | | | 165-ball FBGA (13 × 15 × 1.4 mm) Pb-free | Industrial | |
| CY7C1514KV18-300BZXI | | | | | |
| 250 | CY7C1525KV18-250BZC | 51-85180 | 165-ball FBGA (13 × 15 × 1.4 mm) | Commercial | |
| | CY7C1512KV18-250BZC | | | | |
| | CY7C1514KV18-250BZC | | | | |
| | 250 | CY7C1525KV18-250BZXC | 51-85180 | 165-ball FBGA (13 × 15 × 1.4 mm) Pb-free | Commercial |
| | | CY7C1512KV18-250BZXC | | | |
| | | CY7C1514KV18-250BZXC | | | |
| | 250 | CY7C1512KV18-250BZI | 51-85180 | 165-ball FBGA (13 × 15 × 1.4 mm) | Industrial |
| | | CY7C1514KV18-250BZI | | | |
| | | CY7C1525KV18-250BZXI | 51-85180 | 165-ball FBGA (13 × 15 × 1.4 mm) Pb-free | |
| | | CY7C1512KV18-250BZXI | | | |
| | | CY7C1514KV18-250BZXI | | | |



Ordering Code Definitions

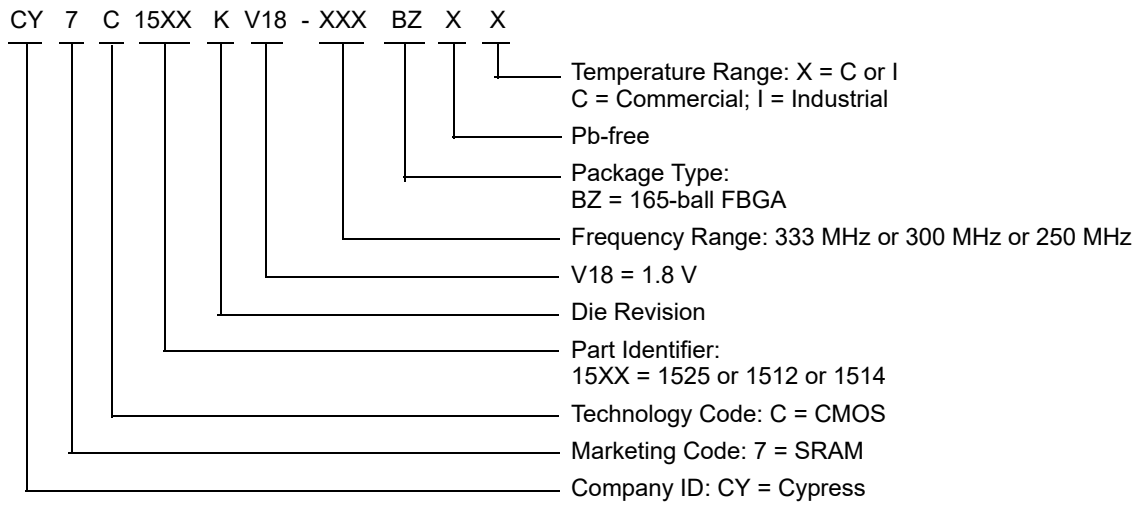



Acronyms

| Acronym | Description |
|---------|--|
| DDR | Double Data Rate |
| FBGA | Fine-Pitch Ball Grid Array |
| HSTL | High-Speed Transceiver Logic |
| I/O | Input/Output |
| JEDEC | Joint Electron Devices Engineering Council |
| JTAG | Joint Test Action Group |
| LMBU | Logical Multiple Bit Upset |
| LSB | Least Significant Bit |
| LSBU | Logical Single Bit Upset |
| MSB | Most Significant Bit |
| PLL | Phase-Locked Loop |
| QDR | Quad Data Rate |
| SEL | Single Event Latch-up |
| SRAM | Static Random Access Memory |
| TAP | Test Access Port |
| TCK | Test Clock |
| TMS | Test Mode Select |
| TDI | Test Data-In |
| TDO | Test Data-Out |
| TTL | Transistor-Transistor Logic |

Document Conventions

Units of Measure

| Symbol | Unit of Measure |
|--------|-----------------|
| °C | degree Celsius |
| MHz | megahertz |
| μA | microampere |
| μs | microsecond |
| mA | milliampere |
| mm | millimeter |
| ms | millisecond |
| ns | nanosecond |
| Ω | ohm |
| % | percent |
| pF | picofarad |
| ps | picosecond |
| V | volt |
| W | watt |

Document History Page

| Document Title: CY7C1525KV18/CY7C1512KV18/CY7C1514KV18, 72-Mbit QDR® II SRAM Two-Word Burst Architecture | | | | |
|--|---------|-----------------|-----------------|--|
| Document Number: 001-00436 | | | | |
| Rev. | ECN No. | Orig. of Change | Submission Date | Description of Change |
| ** | 374703 | SYT | 06/02/2005 | New data sheet. |
| *A | 1103823 | VKN | 05/28/2007 | Updated Selection Guide (Updated details of Maximum operating current). Updated Ordering Information (Updated part numbers). |
| *B | 1699083 | VKN / AESA | 11/02/2007 | Changed status from Advance Information to Preliminary. |
| *C | 2148307 | VKN / AESA | 02/27/2008 | Updated Electrical Characteristics (Updated DC Electrical Characteristics (Added Note 24 and referred the same note in I _{DD} parameter)). Updated Switching Characteristics (Updated Note 31 (Corrected typo); changed minimum value of t _{KC lock} parameter from 2048 cycles to 20 μs). |
| *D | 2606839 | VKN / PYRS | 11/13/2008 | Updated Identification Register Definitions (Changed Revision Number (31:29) from 001 to 000). Updated Power Up Sequence in QDR II SRAM (Updated description; and Figure 4). Updated Maximum Ratings (Changed Ambient Temperature with Power Applied from “-10 °C to +85 °C” to “-55 °C to +125 °C”). Updated Thermal Resistance (Replaced values of Θ _{JA} and Θ _{JC} parameters from TBD to respective Thermal Values for 165-ball FBGA Package). Updated Package Diagram (Changed the package size from 15 × 17 × 1.4 mm to 13 × 15 × 1.4 mm (Removed spec 51-85195 *A and included 51-85180 *A)). |
| *E | 2681899 | VKN / PYRS | 04/01/2009 | Changed status from Preliminary to Final. Updated Ordering Information (No change in part numbers; added disclaimer on top of the Ordering Information table). Post to external web. |
| *F | 2747635 | VKN / AESA | 08/03/2009 | Added Neutron Soft Error Immunity . Updated Ordering Information (Updated part numbers; and modified the disclaimer for the Ordering information). |
| *G | 2767155 | VKN | 09/23/2009 | Updated Capacitance (Changed value of Input Capacitance (C _{IN}) from 2 pF to 4 pF, changed value of Output Capacitance (C _O) from 3 pF to 4 pF). Updated Ordering Information (No change in part numbers; modified Ordering Information disclaimer). |
| *H | 2794726 | VKN | 10/29/2009 | Updated Ordering Information (Updated part numbers). Updated Package Diagram : spec 51-85180 – Changed revision from *A to *B. |
| *I | 2868256 | VKN | 01/28/2010 | Updated Features (Added 350 MHz frequency related information). Updated Selection Guide (Added 350 MHz frequency related information). Updated Electrical Characteristics (Updated DC Electrical Characteristics (Added 350 MHz frequency related information)). Updated Switching Characteristics (Added 350 MHz frequency related information). Updated Ordering Information (Updated part numbers). Updated Package Diagram : spec 51-85180 – Changed revision from *B to *C. |
| *J | 2870201 | NJY | 02/01/2010 | No technical updates. |
| *K | 2899924 | VKN / NJY | 03/26/2010 | Updated Ordering Information (Updated part numbers). |
| *L | 2905951 | VKN / NJY | 04/07/2010 | Updated Ordering Information (Updated part numbers). |
| *M | 3216622 | NJY | 04/05/2011 | Updated to new template. Completing Sunset Review. |
| *N | 3410256 | VIDB | 10/18/2011 | Updated Ordering Information (Updated part numbers). Updated to new template. |



Document History Page (continued)

| Document Title: CY7C1525KV18/CY7C1512KV18/CY7C1514KV18, 72-Mbit QDR® II SRAM Two-Word Burst Architecture Document Number: 001-00436 | | | | |
|--|---------|-----------------|-----------------|--|
| Rev. | ECN No. | Orig. of Change | Submission Date | Description of Change |
| *O | 3441304 | VIDB | 11/21/2011 | Updated Switching Characteristics (Added Note 34 and referred the same note in description of $t_{KC\ lock}$ parameter). Updated Package Diagram : spec 51-85180 – Changed revision from *C to *D. Completing Sunset Review. |
| *P | 3610239 | PRIT / GOPA | 05/08/2012 | Updated Features (Removed CY7C1510KV18 related information). Updated Configurations (Removed CY7C1510KV18 related information). Updated Functional Description (Removed CY7C1510KV18 related information). Updated Selection Guide (Removed 200 MHz, 167 MHz frequencies related information; updated value of Maximum operating current for as “Not offered” for × 9 and × 36 for 350 MHz frequency; removed CY7C1510KV18 related information). Removed Logic Block Diagram – CY7C1510KV18. Updated Pin Configurations (Removed CY7C1510KV18 related information). Updated Pin Definitions (Removed CY7C1510KV18 related information). Updated Functional Overview (Removed CY7C1510KV18 related information). Updated Truth Table (Removed CY7C1510KV18 related information). Updated Write Cycle Descriptions (Removed CY7C1510KV18 related information). Updated Identification Register Definitions (Removed CY7C1510KV18 related information). Updated Electrical Characteristics (Updated DC Electrical Characteristics (Removed 200 MHz, 167 MHz frequencies related information; removed I_{DD} and I_{SB1} parameter details corresponding to × 9 and × 36 for 350 MHz frequency, removed CY7C1510KV18 related information)). Updated Switching Characteristics (Removed 200 MHz, 167 MHz frequencies related information). Updated Package Diagram (spec 51-85180 (changed revision from *D to *E)). |
| *Q | 3841412 | YHB / GOPA | 12/14/2012 | Updated Ordering Information (Updated part numbers). Updated Package Diagram (spec 51-85180 (Changed revision from *E to *F)). Completing Sunset Review. |
| *R | 4371693 | PRIT | 05/06/2014 | Updated Application Example : Updated Figure 2 . Updated Thermal Resistance : Updated values of Θ_{JA} parameter. Included Θ_{JB} parameter and its details. Updated to new template. |
| *S | 4580515 | PRIT | 11/26/2014 | Updated Functional Description : Added “For a complete list of related documentation, click here .” at the end. Completing Sunset Review. |
| *T | 4916588 | PRIT | 09/11/2015 | Updated Switching Waveforms : Updated Read/Write/Deselect Sequence : Replaced “Waveform for 2.0 Cycle Read Latency” with “Waveform for 1.5 Cycle Read Latency” in caption of Figure 6 . Updated Package Diagram : spec 51-85180 – Changed revision from *F to *G. Updated to new template. |
| *U | 5071226 | PRIT | 01/04/2016 | No technical updates. Completing Sunset Review. |



Document History Page (continued)

| Document Title: CY7C1525KV18/CY7C1512KV18/CY7C1514KV18, 72-Mbit QDR® II SRAM Two-Word Burst Architecture Document Number: 001-00436 | | | | |
|--|---------|-----------------|-----------------|--|
| Rev. | ECN No. | Orig. of Change | Submission Date | Description of Change |
| *V | 6038611 | CNX | 01/19/2018 | Updated Ordering Information : Updated part numbers. Updated to new template. Completing Sunset Review. |



Sales, Solutions, and Legal Information

Worldwide Sales and Design Support

Cypress maintains a worldwide network of offices, solution centers, manufacturer's representatives, and distributors. To find the office closest to you, visit us at [Cypress Locations](#).

Products

| | |
|-------------------------------|--|
| Arm® Cortex® Microcontrollers | cypress.com/arm |
| Automotive | cypress.com/automotive |
| Clocks & Buffers | cypress.com/clocks |
| Interface | cypress.com/interface |
| Internet of Things | cypress.com/iot |
| Memory | cypress.com/memory |
| Microcontrollers | cypress.com/mcu |
| PSoC | cypress.com/psoc |
| Power Management ICs | cypress.com/pmic |
| Touch Sensing | cypress.com/touch |
| USB Controllers | cypress.com/usb |
| Wireless Connectivity | cypress.com/wireless |

PSoC® Solutions

[PSoC 1](#) | [PSoC 3](#) | [PSoC 4](#) | [PSoC 5LP](#) | [PSoC 6 MCU](#)

Cypress Developer Community

[Community](#) | [Projects](#) | [Video](#) | [Blogs](#) | [Training](#) | [Components](#)

Technical Support

cypress.com/support

© Cypress Semiconductor Corporation, 2005-2018. This document is the property of Cypress Semiconductor Corporation and its subsidiaries, including Spansion LLC ("Cypress"). This document, including any software or firmware included or referenced in this document ("Software"), is owned by Cypress under the intellectual property laws and treaties of the United States and other countries worldwide. Cypress reserves all rights under such laws and treaties and does not, except as specifically stated in this paragraph, grant any license under its patents, copyrights, trademarks, or other intellectual property rights. If the Software is not accompanied by a license agreement and you do not otherwise have a written agreement with Cypress governing the use of the Software, then Cypress hereby grants you a personal, non-exclusive, nontransferable license (without the right to sublicense) (1) under its copyright rights in the Software (a) for Software provided in source code form, to modify and reproduce the Software solely for use with Cypress hardware products, only internally within your organization, and (b) to distribute the Software in binary code form externally to end users (either directly or indirectly through resellers and distributors), solely for use on Cypress hardware product units, and (2) under those claims of Cypress's patents that are infringed by the Software (as provided by Cypress, unmodified) to make, use, distribute, and import the Software solely for use with Cypress hardware products. Any other use, reproduction, modification, translation, or compilation of the Software is prohibited.

TO THE EXTENT PERMITTED BY APPLICABLE LAW, CYPRESS MAKES NO WARRANTY OF ANY KIND, EXPRESS OR IMPLIED, WITH REGARD TO THIS DOCUMENT OR ANY SOFTWARE OR ACCOMPANYING HARDWARE, INCLUDING, BUT NOT LIMITED TO, THE IMPLIED WARRANTIES OF MERCHANTABILITY AND FITNESS FOR A PARTICULAR PURPOSE. To the extent permitted by applicable law, Cypress reserves the right to make changes to this document without further notice. Cypress does not assume any liability arising out of the application or use of any product or circuit described in this document. Any information provided in this document, including any sample design information or programming code, is provided only for reference purposes. It is the responsibility of the user of this document to properly design, program, and test the functionality and safety of any application made of this information and any resulting product. Cypress products are not designed, intended, or authorized for use as critical components in systems designed or intended for the operation of weapons, weapons systems, nuclear installations, life-support devices or systems, other medical devices or systems (including resuscitation equipment and surgical implants), pollution control or hazardous substances management, or other uses where the failure of the device or system could cause personal injury, death, or property damage ("Unintended Uses"). A critical component is any component of a device or system whose failure to perform can be reasonably expected to cause the failure of the device or system, or to affect its safety or effectiveness. Cypress is not liable, in whole or in part, and you shall and hereby do release Cypress from any claim, damage, or other liability arising from or related to all Unintended Uses of Cypress products. You shall indemnify and hold Cypress harmless from and against all claims, costs, damages, and other liabilities, including claims for personal injury or death, arising from or related to any Unintended Uses of Cypress products.

Cypress, the Cypress logo, Spansion, the Spansion logo, and combinations thereof, WICED, PSoC, CapSense, EZ-USB, F-RAM, and Traveo are trademarks or registered trademarks of Cypress in the United States and other countries. For a more complete list of Cypress trademarks, visit cypress.com. Other names and brands may be claimed as property of their respective owners.

Looking for pricing, stock, or lifecycle information?

Click below to explore more details on WIN SOURCE:

- ⊖ [View CY7C1514KV18-250BZC on WIN SOURCE](#)
- ⊖ [Cypress Semiconductor Corp Information](#)

Optimize Your Supply Chain with WIN SOURCE Solutions

- ✓ Global Sourcing Solution
- ✓ Obsolete Management
- ✓ Cost Control Management
- ✓ Shortage Management
- ✓ Alternative Solution
- ✓ Excess Inventory Management