



**THE DATASHEET OF
CY7C1420AV18-250BZC**





CY7C1418AV18
CY7C1420AV18

36 Mbit DDR II SRAM Two Word Burst Architecture

Features

- 36 Mbit density (2M x 18, 1M x 36)
- 300 MHz clock for high bandwidth
- Two word burst for reducing address bus frequency
- Double Data Rate (DDR) interfaces (data transferred at 600MHz) at 300 MHz for DDR II
- Two input clocks (K and \bar{K}) for precise DDR timing
 - SRAM uses rising edges only
- Two input clocks for output data (C and \bar{C}) to minimize clock skew and flight time mismatches
- Echo clocks (CQ and \bar{CQ}) simplify data capture in high speed systems
- Synchronous internally self timed writes
- 1.8V core power supply with HSTL inputs and outputs
- Variable drive HSTL output buffers
- Expanded HSTL output voltage (1.4V– V_{DD})
- Available in 165-Ball FBGA package (15 x 17 x 1.4 mm)
- Offered in both in Pb-free and non Pb-free packages
- JTAG 1149.1 compatible test access port
- Delay Lock Loop (DLL) for accurate data placement

Configurations

CY7C1418AV18 – 2M x 18
 CY7C1420AV18 – 1M x 36

Selection Guide

Description		300 MHz	278 MHz	250 MHz	200 MHz	167 MHz	Unit
Maximum Operating Frequency		300	278	250	200	167	MHz
Maximum Operating Current	x18	900	835	760	620	525	mA
	x36	990	910	825	675	570	

Functional Description

The CY7C1418AV18, and CY7C1420AV18 are 1.8V Synchronous Pipelined SRAM equipped with DDR II architecture. The DDR II consists of an SRAM core with advanced synchronous peripheral circuitry and a 1 bit burst counter. Addresses for read and write are latched on alternate rising edges of the input (K) clock. Write data is registered on the rising edges of both K and \bar{K} . Read data is driven on the rising edges of C and \bar{C} if provided, or on the rising edge of K and \bar{K} if C/ \bar{C} are not provided. On CY7C1418AV18 and CY7C1420AV18, the burst counter takes in the least significant bit of the external address and bursts two 18 bit words in the case of CY7C1418AV18 and two 36 bit words in the case of CY7C1420AV18 sequentially into or out of the device.

Asynchronous inputs include an output impedance matching input (ZQ). Synchronous data outputs (Q, sharing the same physical pins as the data inputs D) are tightly matched to the two output echo clocks CQ/ \bar{CQ} , eliminating the need for separately capturing data from each individual DDR SRAM in the system design. Output data clocks (C/ \bar{C}) enable maximum system clocking and data synchronization flexibility.

All synchronous inputs pass through input registers controlled by the K or \bar{K} input clocks. All data outputs pass through output registers controlled by the C or \bar{C} (or K or \bar{K} in a single clock domain) input clocks. Writes are conducted with on-chip synchronous self timed write circuitry.

Logic Block Diagram – CY7C1418AV18

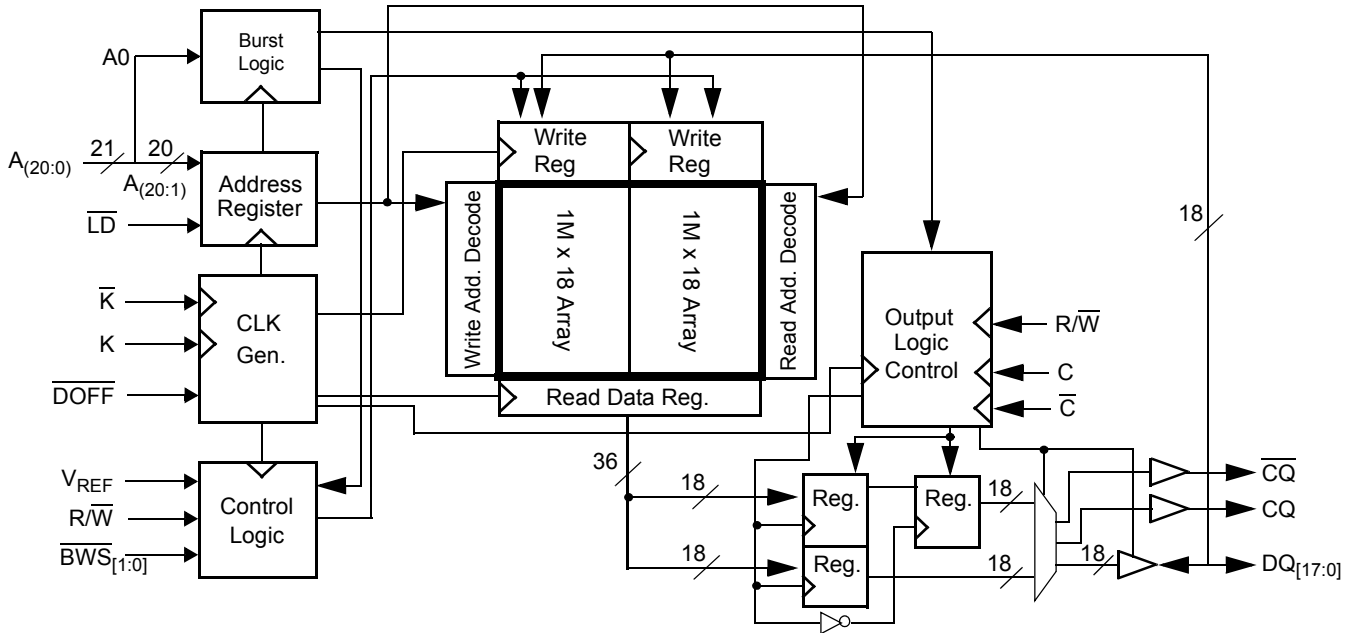

Logic Block Diagram – CY7C1420AV18

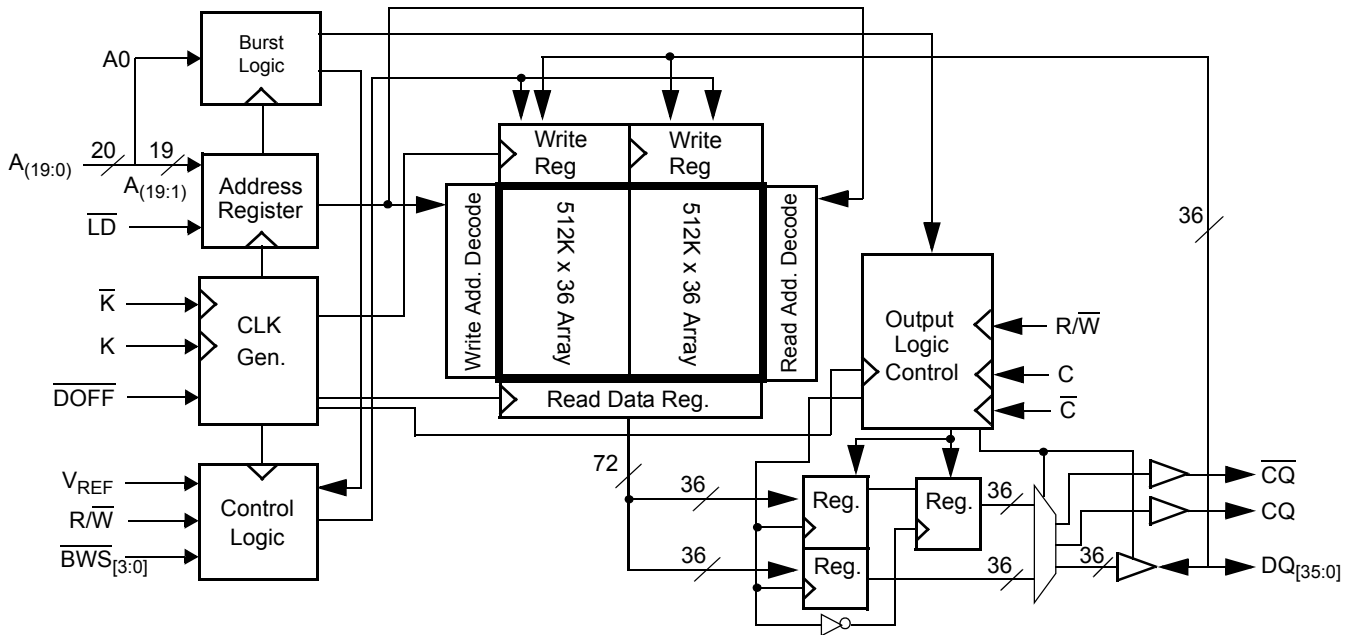

Pin Configuration

The pin configuration for CY7C1418AV18, and CY7C1420AV18 follow. [1]

165-Ball FBGA (15 x 17 x 1.4 mm) Pinout

Table 1. CY7C1418AV18 (2M x 18)

	1	2	3	4	5	6	7	8	9	10	11
A	$\overline{\text{CQ}}$	NC/72M	A	$\overline{\text{R/W}}$	$\overline{\text{BWS}}_1$	$\overline{\text{K}}$	NC/144M	$\overline{\text{LD}}$	A	A	CQ
B	NC	DQ9	NC	A	NC/288M	K	$\overline{\text{BWS}}_0$	A	NC	NC	DQ8
C	NC	NC	NC	V_{SS}	A	A0	A	V_{SS}	NC	DQ7	NC
D	NC	NC	DQ10	V_{SS}	V_{SS}	V_{SS}	V_{SS}	V_{SS}	NC	NC	NC
E	NC	NC	DQ11	V_{DDQ}	V_{SS}	V_{SS}	V_{SS}	V_{DDQ}	NC	NC	DQ6
F	NC	DQ12	NC	V_{DDQ}	V_{DD}	V_{SS}	V_{DD}	V_{DDQ}	NC	NC	DQ5
G	NC	NC	DQ13	V_{DDQ}	V_{DD}	V_{SS}	V_{DD}	V_{DDQ}	NC	NC	NC
H	$\overline{\text{DOFF}}$	V_{REF}	V_{DDQ}	V_{DDQ}	V_{DD}	V_{SS}	V_{DD}	V_{DDQ}	V_{DDQ}	V_{REF}	ZQ
J	NC	NC	NC	V_{DDQ}	V_{DD}	V_{SS}	V_{DD}	V_{DDQ}	NC	DQ4	NC
K	NC	NC	DQ14	V_{DDQ}	V_{DD}	V_{SS}	V_{DD}	V_{DDQ}	NC	NC	DQ3
L	NC	DQ15	NC	V_{DDQ}	V_{SS}	V_{SS}	V_{SS}	V_{DDQ}	NC	NC	DQ2
M	NC	NC	NC	V_{SS}	V_{SS}	V_{SS}	V_{SS}	V_{SS}	NC	DQ1	NC
N	NC	NC	DQ16	V_{SS}	A	A	A	V_{SS}	NC	NC	NC
P	NC	NC	DQ17	A	A	C	A	A	NC	NC	DQ0
R	TDO	TCK	A	A	A	$\overline{\text{C}}$	A	A	A	TMS	TDI

Table 2. CY7C1420AV18 (1M x 36)

	1	2	3	4	5	6	7	8	9	10	11
A	$\overline{\text{CQ}}$	NC/144M	A	$\overline{\text{R/W}}$	$\overline{\text{BWS}}_2$	$\overline{\text{K}}$	$\overline{\text{BWS}}_1$	$\overline{\text{LD}}$	A	NC/72M	CQ
B	NC	DQ27	DQ18	A	$\overline{\text{BWS}}_3$	K	$\overline{\text{BWS}}_0$	A	NC	NC	DQ8
C	NC	NC	DQ28	V_{SS}	A	A0	A	V_{SS}	NC	DQ17	DQ7
D	NC	DQ29	DQ19	V_{SS}	V_{SS}	V_{SS}	V_{SS}	V_{SS}	NC	NC	DQ16
E	NC	NC	DQ20	V_{DDQ}	V_{SS}	V_{SS}	V_{SS}	V_{DDQ}	NC	DQ15	DQ6
F	NC	DQ30	DQ21	V_{DDQ}	V_{DD}	V_{SS}	V_{DD}	V_{DDQ}	NC	NC	DQ5
G	NC	DQ31	DQ22	V_{DDQ}	V_{DD}	V_{SS}	V_{DD}	V_{DDQ}	NC	NC	DQ14
H	$\overline{\text{DOFF}}$	V_{REF}	V_{DDQ}	V_{DDQ}	V_{DD}	V_{SS}	V_{DD}	V_{DDQ}	V_{DDQ}	V_{REF}	ZQ
J	NC	NC	DQ32	V_{DDQ}	V_{DD}	V_{SS}	V_{DD}	V_{DDQ}	NC	DQ13	DQ4
K	NC	NC	DQ23	V_{DDQ}	V_{DD}	V_{SS}	V_{DD}	V_{DDQ}	NC	DQ12	DQ3
L	NC	DQ33	DQ24	V_{DDQ}	V_{SS}	V_{SS}	V_{SS}	V_{DDQ}	NC	NC	DQ2
M	NC	NC	DQ34	V_{SS}	V_{SS}	V_{SS}	V_{SS}	V_{SS}	NC	DQ11	DQ1
N	NC	DQ35	DQ25	V_{SS}	A	A	A	V_{SS}	NC	NC	DQ10
P	NC	NC	DQ26	A	A	C	A	A	NC	DQ9	DQ0
R	TDO	TCK	A	A	A	$\overline{\text{C}}$	A	A	A	TMS	TDI

Note

1. NC/72M, NC/144M, and NC/288M are not connected to the die and can be tied to any voltage level.

Pin Definitions

Pin Name	IO	Pin Description
DQ _[x:0]	Input Output-Synchronous	Data Input Output Signals. Inputs are sampled on the rising edge of K and \bar{K} clocks during valid write operations. These pins drive out the requested data during a read operation. Valid data is driven out on the rising edge of both the C and \bar{C} clocks during read operations or K and \bar{K} when in single clock mode. When read access is deselected, Q _[x:0] are automatically tri-stated. CY7C1418AV18 – DQ _[17:0] CY7C1420AV18 – DQ _[35:0]
LD	Input-Synchronous	Synchronous Load. This input is brought LOW when a bus cycle sequence is defined. This definition includes address and read/write direction. All transactions operate on a burst of 2 data. LD must meet the setup and hold times around edge of K.
BWS ₀ , BWS ₁ , BWS ₂ , BWS ₃	Input-Synchronous	Byte Write Select 0, 1, 2, and 3 – Active LOW. Sampled on the rising edge of the K and \bar{K} clocks during write operations. Used to select which byte is written into the device during the current portion of the write operations. Bytes not written remain unaltered. CY7C1418AV18 – $\overline{\text{BWS}}_0$ controls D _[8:0] and $\overline{\text{BWS}}_1$ controls D _[17:9] CY7C1420AV18 – $\overline{\text{BWS}}_0$ controls D _[8:0] , $\overline{\text{BWS}}_1$ controls D _[17:9] , $\overline{\text{BWS}}_2$ controls D _[26:18] , and $\overline{\text{BWS}}_3$ controls D _[35:27] . All the Byte Write Selects are sampled on the same edge as the data. Deselecting a Byte Write Select ignores the corresponding byte of data and it is not written into the device.
A, A0	Input-Synchronous	Address Inputs. These address inputs are multiplexed for both read and write operations. Internally, the device is organized as 2M x 18 (2 arrays each of 1M x 18) for CY7C1418AV18, and 1M x 36 (2 arrays each of 512K x 36) for CY7C1420AV18. CY7C1418AV18 – A0 is the input to the burst counter. These are incremented in a linear fashion internally. 21 address inputs are needed to access the entire memory array. CY7C1420AV18 – A0 is the input to the burst counter. These are incremented in a linear fashion internally. 20 address inputs are needed to access the entire memory array. All the address inputs are ignored when the appropriate port is deselected.
R/W	Input-Synchronous	Synchronous Read or Write Input. When LD is LOW, this input designates the access type (read when R/W is HIGH, write when R/W is LOW) for loaded address. R/W must meet the setup and hold times around edge of K.
C	Input Clock	Positive Input Clock for Output Data. C is used in conjunction with \bar{C} to clock out the read data from the device. Use the C and \bar{C} together to deskew the flight times of various devices on the board back to the controller. See Application Example on page 7 for further details.
\bar{C}	Input Clock	Negative Input Clock for Output Data. \bar{C} is used in conjunction with C to clock out the read data from the device. Use the C and \bar{C} together to deskew the flight times of various devices on the board back to the controller. See Application Example on page 7 for further details.
K	Input Clock	Positive Input Clock Input. The rising edge of K is used to capture synchronous inputs to the device and to drive out data through Q _[x:0] when in single clock mode. All accesses are initiated on the rising edge of K.
\bar{K}	Input Clock	Negative Input Clock Input. \bar{K} is used to capture synchronous data being presented to the device and to drive out data through Q _[x:0] when in single clock mode.
CQ	Output Clock	CQ Referenced with Respect to C. This is a free-running clock and is synchronized to the input clock for output data (C) of the DDR II. In the single clock mode, CQ is generated with respect to K. The timing for the echo clocks is shown in the Switching Characteristics on page 21.
\bar{CQ}	Output Clock	\bar{CQ} Referenced with Respect to \bar{C}. This is a free-running clock and is synchronized to the input clock for output data (\bar{C}) of the DDR II. In the single clock mode, \bar{CQ} is generated with respect to \bar{K} . The timing for the echo clocks is shown in the Switching Characteristics on page 21.
ZQ	Input	Output Impedance Matching Input. This input is used to tune the device outputs to the system data bus impedance. CQ, \bar{CQ} , and Q _[x:0] output impedance are set to 0.2 x RQ, where RQ is a resistor connected between ZQ and ground. Alternatively, connect this pin directly to V _{DDQ} , which enables the minimum impedance mode. This pin cannot be connected directly to GND or left unconnected.
DOFF	Input	DLL Turn Off – Active LOW. Connecting this pin to ground turns off the DLL inside the device. The timing in the DLL turned off operation differs from those listed in this data sheet.

Pin Definitions (continued)

Pin Name	IO	Pin Description
TDO	Output	TDO for JTAG.
TCK	Input	TCK Pin for JTAG.
TDI	Input	TDI Pin for JTAG.
TMS	Input	TMS Pin for JTAG.
NC	N/A	Not Connected to the Die. Tie to any voltage level.
NC/72M	N/A	Not Connected to the Die. Tie to any voltage level.
NC/144M	N/A	Not Connected to the Die. Tie to any voltage level.
NC/288M	N/A	Not Connected to the Die. Tie to any voltage level.
V _{REF}	Input-Reference	Reference Voltage Input. Static input used to set the reference level for HSTL inputs, outputs, and AC measurement points.
V _{DD}	Power Supply	Power Supply Inputs to the Core of the Device.
V _{SS}	Ground	Ground for the Device.
V _{DDQ}	Power Supply	Power Supply Inputs for the Outputs of the Device.

Functional Overview

The CY7C1418AV18, and CY7C1420AV18 are synchronous pipelined Burst SRAMs equipped with a DDR interface.

Accesses are initiated on the rising edge of the positive input clock (K). All synchronous input timing is referenced from the rising edge of the input clocks (K and \bar{K}) and all output timing is referenced to the rising edge of the output clocks (C/\bar{C} or K/\bar{K} when in single clock mode).

All synchronous data inputs ($D_{[x:0]}$) pass through input registers controlled by the rising edge of the input clocks (K and \bar{K}). All synchronous data outputs ($Q_{[x:0]}$) pass through output registers controlled by the rising edge of the output clocks (C/\bar{C} or K/\bar{K} when in single clock mode).

All synchronous control (R/\bar{W} , \bar{LD} , $\overline{BWS}_{[0:X]}$) inputs pass through input registers controlled by the rising edge of the input clock (K).

CY7C1418AV18 is described in the following sections. The same basic descriptions apply to CY7C1420AV18.

Read Operations for DDR II

The CY7C1418AV18 is organized internally as two arrays of 1M x 18. Accesses are completed in a burst of two sequential 18 bit data words. Read operations are initiated by asserting R/\bar{W} HIGH and \bar{LD} LOW at the rising edge of the positive input clock (K). The address presented to address inputs is stored in the read address register and the least significant bit of the address is presented to the burst counter. The burst counter increments the address in a linear fashion. Following the next K clock rise, the corresponding 18 bit word of data from this address location is driven onto the $Q_{[17:0]}$ using \bar{C} as the output timing reference. On the subsequent rising edge of C the next 18 bit data word from the address location generated by the burst counter is driven onto the $Q_{[17:0]}$. The requested data is valid 0.45 ns from the rising edge of the output clock (C or \bar{C} , or K and \bar{K} when in single clock mode, 200 MHz and 250 MHz device). To maintain the internal logic, each read access must be allowed to complete. Initiate read accesses on every rising edge of the positive input clock (K).

On deselecting the read access, the CY7C1418AV18 first completes the pending read transactions. Synchronous internal circuitry automatically tri-states the output following the next rising edge of the positive output clock (C). This enables for a transition between the devices without the insertion of wait states in a depth expanded memory.

Write Operations

Write operations are initiated by asserting R/\bar{W} LOW and \bar{LD} LOW at the rising edge of the positive input clock (K). The address presented to address inputs is stored in the write address register and the least significant bit of the address is presented to the burst counter. The burst counter increments the address in a linear fashion. On the following K clock rise the data presented to $D_{[17:0]}$ is latched and stored into the 18 bit write data register, provided $\overline{BWS}_{[1:0]}$ are both asserted active. On the subsequent rising edge of the negative input clock (\bar{K}) the infor-

mation presented to $D_{[17:0]}$ is also stored into the write data register, provided $\overline{BWS}_{[1:0]}$ are both asserted active. The 36 bits of data are then written into the memory array at the specified location. Initiate write accesses on every rising edge of the positive input clock (K). Doing so pipelines the data flow such that 18 bits of data transfers into the device on every rising edge of the input clocks (K and \bar{K}).

When write access is deselected, the device ignores all inputs after the pending write operations have been completed.

Byte Write Operations

Byte write operations are supported by the CY7C1418AV18. A write operation is initiated as described in the [Write Operations](#) section. The bytes that are written are determined by \overline{BWS}_0 and \overline{BWS}_1 , which are sampled with each set of 18 bit data words. Asserting the appropriate Byte Write Select input during the data portion of a write latches the data being presented and writes it into the device. Deasserting the Byte Write Select input during the data portion of a write enables the data stored in the device for that byte to remain unaltered. Use this feature to simplify read, modify, or write operations to a byte write operation.

Single Clock Mode

Use the CY7C1418AV18 with a single clock that controls both the input and output registers. In this mode the device recognizes only a single pair of input clocks (K and \bar{K}) that control both the input and output registers. This operation is identical to the operation if the device had zero skew between the K/\bar{K} and C/\bar{C} clocks. All timing parameters remain the same in this mode. To use this mode of operation, the user must tie C and \bar{C} HIGH at power on. This function is a strap option and not alterable during device operation.

DDR Operation

The CY7C1418AV18 enables high performance operation through high clock frequencies (achieved through pipelining) and double data rate mode of operation. The CY7C1418AV18 requires a single No Operation (NOP) cycle during transition from a read to a write cycle. At higher frequencies, some applications may require a second NOP cycle to avoid contention.

If a read occurs after a write cycle, address and data for the write are stored in registers. The write information must be stored because the SRAM cannot perform the last word write to the array without conflicting with the read. The data stays in this register until the next write cycle occurs. On the first write cycle after the read(s), the stored data from the earlier write is written into the SRAM array. This is called a posted write.

If a read is performed on the same address on which a write is performed in the previous cycle, the SRAM reads out the most current data. The SRAM does this by bypassing the memory array and reading the data from the registers.

Depth Expansion

Depth expansion requires replicating the \bar{LD} control signal for each bank. All other control signals can be common between banks as appropriate.

Programmable Impedance

An external resistor, R_Q , must be connected between the ZQ pin on the SRAM and V_{SS} to allow the SRAM to adjust its output driver impedance. The value of R_Q must be 5x the value of the intended line impedance driven by the SRAM, The allowable range of R_Q to guarantee impedance matching with a tolerance of $\pm 15\%$ is between 175Ω and 350Ω , with $V_{DDQ} = 1.5V$. The output impedance is adjusted every 1024 cycles upon power up to account for drifts in supply voltage and temperature.

Echo Clocks

Echo clocks are provided on the DDR II to simplify data capture on high speed systems. Two echo clocks are generated by the DDR II. CQ is referenced with respect to C and \overline{CQ} is referenced with respect to \overline{C} . These are free-running clocks and are

synchronized to the output clock of the DDR II. In the single clock mode, CQ is generated with respect to K, and \overline{CQ} is generated with respect to \overline{K} . The timings for the echo clocks is shown in the AC Timing Table.

DLL

These chips use a Delay Lock Loop (DLL) that is designed to function between 120 MHz and the specified maximum clock frequency. During power up, when the DOFF is tied HIGH, the DLL is locked after 1024 cycles of stable clock. The DLL can also be reset by slowing or stopping the input clock K and \overline{K} for a minimum of 30 ns. However, it is not necessary to reset the DLL to lock to the desired frequency. The DLL automatically locks 1024 clock cycles after a stable clock is presented. The DLL may be disabled by applying ground to the DOFF pin. For information refer to the application note AN5062, [DLL Considerations in QDRII/DDRII/QDRII+/DDRII+](#).

Application Example

Figure 1 shows two DDR II used in an application.

Figure 1. Application Example

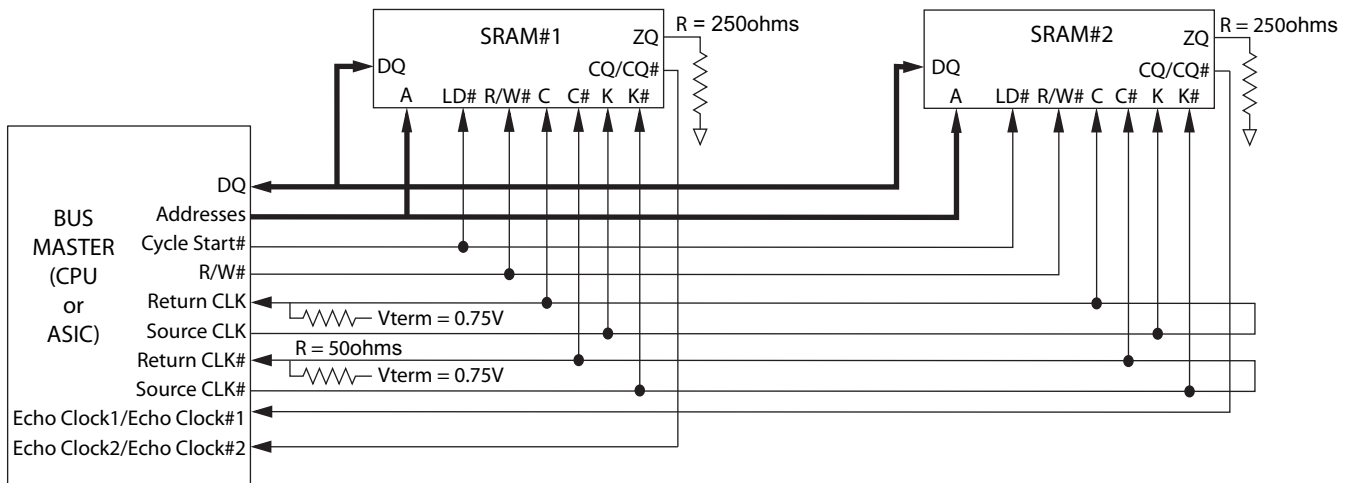

Truth Table

The truth table for the CY7C1418AV18, and CY7C1420AV18 follows. [2, 3, 4, 5, 6, 7]

Operation	K	LD	R/W	DQ	DQ
Write Cycle: Load address; wait one cycle; input write data on consecutive K and \bar{K} rising edges.	L-H	L	L	D(A1) at K(t + 1) \uparrow	D(A2) at K(t + 1) \uparrow
Read Cycle: Load address; wait one and a half cycle; read data on consecutive C and \bar{C} rising edges.	L-H	L	H	Q(A1) at C(t + 1) \uparrow	Q(A2) at C(t + 2) \uparrow
NOP: No Operation	L-H	H	X	High Z	High Z
Standby: Clock Stopped	Stopped	X	X	Previous State	Previous State

Burst Address Table

(CY7C1418AV18, CY7C1420AV18)

First Address (External)	Second Address (Internal)
X..X0	X..X1
X..X1	X..X0

Write Cycle Descriptions

The write cycle description table for CY7C1418AV18 follows. [2, 8]

BWS ₀	BWS ₁	K	\bar{K}	Comments
L	L	L-H	-	During the data portion of a write sequence: Both bytes (D _[17:0]) are written into the device.
L	L	-	L-H	During the data portion of a write sequence: Both bytes (D _[17:0]) are written into the device.
L	H	L-H	-	During the data portion of a write sequence: Only the lower byte (D _[8:0]) is written into the device, D _[17:9] remains unaltered.
L	H	-	L-H	During the data portion of a write sequence: Only the lower byte (D _[8:0]) is written into the device, D _[17:9] remains unaltered.
H	L	L-H	-	During the data portion of a write sequence: Only the upper byte (D _[17:9]) is written into the device, D _[8:0] remains unaltered.
H	L	-	L-H	During the data portion of a write sequence: Only the upper byte (D _[17:9]) is written into the device, D _[8:0] remains unaltered.
H	H	L-H	-	No data is written into the devices during this portion of a write operation.
H	H	-	L-H	No data is written into the devices during this portion of a write operation.

Notes

- X = "Don't Care," H = Logic HIGH, L = Logic LOW, \uparrow represents rising edge.
- Device powers up deselected with the outputs in a tri-state condition.
- On CY7C1418AV18 and CY7C1420AV18, "A1" represents address location latched by the devices when transaction was initiated and "A2" represents the addresses sequence in the burst.
- "t" represents the cycle at which a read/write operation is started. t + 1 and t + 2 are the first and second clock cycles succeeding the "t" clock cycle.
- Data inputs are registered at K and \bar{K} rising edges. Data outputs are delivered on C and \bar{C} rising edges, except when in single clock mode.
- It is recommended that K = \bar{K} and C = \bar{C} = HIGH when clock is stopped. This is not essential, but permits most rapid restart by overcoming transmission line charging symmetrically.
- Is based on a write cycle that was initiated in accordance with the [Write Cycle Descriptions](#) table. \overline{BWS}_0 , \overline{BWS}_1 , \overline{BWS}_2 , and \overline{BWS}_3 can be altered on different portions of a write cycle, as long as the setup and hold requirements are achieved.

Write Cycle Descriptions

The write cycle description table for CY7C1420AV18 follows. [2, 8]

$\overline{\text{BWS}}_0$	$\overline{\text{BWS}}_1$	$\overline{\text{BWS}}_2$	$\overline{\text{BWS}}_3$	K	$\overline{\text{K}}$	Comments
L	L	L	L	L-H	-	During the Data portion of a write sequence, all four bytes ($D_{[35:0]}$) are written into the device.
L	L	L	L	-	L-H	During the Data portion of a write sequence, all four bytes ($D_{[35:0]}$) are written into the device.
L	H	H	H	L-H	-	During the Data portion of a write sequence, only the lower byte ($D_{[8:0]}$) is written into the device. $D_{[35:9]}$ remains unaltered.
L	H	H	H	-	L-H	During the Data portion of a write sequence, only the lower byte ($D_{[8:0]}$) is written into the device. $D_{[35:9]}$ remains unaltered.
H	L	H	H	L-H	-	During the Data portion of a write sequence, only the byte ($D_{[17:9]}$) is written into the device. $D_{[8:0]}$ and $D_{[35:18]}$ remains unaltered.
H	L	H	H	-	L-H	During the Data portion of a write sequence, only the byte ($D_{[17:9]}$) is written into the device. $D_{[8:0]}$ and $D_{[35:18]}$ remains unaltered.
H	H	L	H	L-H	-	During the Data portion of a write sequence, only the byte ($D_{[26:18]}$) is written into the device. $D_{[17:0]}$ and $D_{[35:27]}$ remains unaltered.
H	H	L	H	-	L-H	During the Data portion of a write sequence, only the byte ($D_{[26:18]}$) is written into the device. $D_{[17:0]}$ and $D_{[35:27]}$ remains unaltered.
H	H	H	L	L-H	-	During the Data portion of a write sequence, only the byte ($D_{[35:27]}$) is written into the device. $D_{[26:0]}$ remains unaltered.
H	H	H	L	-	L-H	During the Data portion of a write sequence, only the byte ($D_{[35:27]}$) is written into the device. $D_{[26:0]}$ remains unaltered.
H	H	H	H	L-H	-	No data is written into the device during this portion of a write operation.
H	H	H	H	-	L-H	No data is written into the device during this portion of a write operation.

IEEE 1149.1 Serial Boundary Scan (JTAG)

These SRAMs incorporate a serial boundary scan Test Access Port (TAP) in the FBGA package. This part is fully compliant with IEEE Standard #1149.1-1900. The TAP operates using JEDEC standard 1.8V IO logic levels.

Disabling the JTAG Feature

It is possible to operate the SRAM without using the JTAG feature. To disable the TAP controller, TCK must be tied LOW (V_{SS}) to prevent clocking of the device. TDI and TMS are internally pulled up and may be unconnected. They may alternatively be connected to V_{DD} through a pull up resistor. TDO must be left unconnected. Upon power up, the device comes up in a reset state, which does not interfere with the operation of the device.

Test Access Port—Test Clock

The test clock is used only with the TAP controller. All inputs are captured on the rising edge of TCK. All outputs are driven from the falling edge of TCK.

Test Mode Select (TMS)

The TMS input is used to give commands to the TAP controller and is sampled on the rising edge of TCK. This pin may be left unconnected if the TAP is not used. The pin is pulled up internally, resulting in a logic HIGH level.

Test Data-In (TDI)

The TDI pin is used to serially input information into the registers and can be connected to the input of any of the registers. The register between TDI and TDO is chosen by the instruction that is loaded into the TAP instruction register. For information on loading the instruction register, see the [TAP Controller State Diagram](#) on page 12. TDI is internally pulled up and can be unconnected if the TAP is unused in an application. TDI is connected to the most significant bit (MSB) on any register.

Test Data-Out (TDO)

The TDO output pin is used to serially clock data out from the registers. The output is active, depending upon the current state of the TAP state machine (see [Instruction Codes](#) on page 15). The output changes on the falling edge of TCK. TDO is connected to the least significant bit (LSB) of any register.

Performing a TAP Reset

A Reset is performed by forcing TMS HIGH (V_{DD}) for five rising edges of TCK. This Reset does not affect the operation of the SRAM and can be performed while the SRAM is operating. At power up, the TAP is reset internally to ensure that TDO comes up in a High Z state.

TAP Registers

Registers are connected between the TDI and TDO pins to scan the data in and out of the SRAM test circuitry. Only one register can be selected at a time through the instruction registers. Data is serially loaded into the TDI pin on the rising edge of TCK. Data is output on the TDO pin on the falling edge of TCK.

Instruction Register

Three bit instructions can be serially loaded into the instruction register. This register is loaded when it is placed between the TDI and TDO pins, as shown in [on page 13](#). Upon power up, the instruction register is loaded with the IDCODE instruction. It is also loaded with the IDCODE instruction if the controller is placed in a reset state, as described in the previous section.

When the TAP controller is in the Capture-IR state, the two least significant bits are loaded with a binary “01” pattern to allow for fault isolation of the board level serial test path.

Bypass Register

To save time when serially shifting data through registers, it is sometimes advantageous to skip certain chips. The bypass register is a single bit register that can be placed between TDI and TDO pins. This enables shifting of data through the SRAM with minimal delay. The bypass register is set LOW (V_{SS}) when the BYPASS instruction is executed.

Boundary Scan Register

The boundary scan register is connected to all of the input and output pins on the SRAM. Several No Connect (NC) pins are also included in the scan register to reserve pins for higher density devices.

The boundary scan register is loaded with the contents of the RAM input and output ring when the TAP controller is in the Capture-DR state and is then placed between the TDI and TDO pins when the controller is moved to the Shift-DR state. The EXTEST, SAMPLE/PRELOAD, and SAMPLE Z instructions can be used to capture the contents of the input and output ring.

The [Boundary Scan Order](#) on page 16 shows the order in which the bits are connected. Each bit corresponds to one of the bumps on the SRAM package. The MSB of the register is connected to TDI, and the LSB is connected to TDO.

Identification (ID) Register

The ID register is loaded with a vendor-specific, 32 bit code during the Capture-DR state when the IDCODE command is loaded in the instruction register. The IDCODE is hardwired into the SRAM and can be shifted out when the TAP controller is in the Shift-DR state. The ID register has a vendor code and other information described in [Identification Register Definitions](#) on page 15.

TAP Instruction Set

Eight different instructions are possible with the three bit instruction register. All combinations are listed in [Instruction Codes](#) on page 15. Three of these instructions are listed as RESERVED and must not be used. The other five instructions are described in this section in detail.

Instructions are loaded into the TAP controller during the Shift-IR state when the instruction register is placed between TDI and TDO. During this state, instructions are shifted through the instruction register through the TDI and TDO pins. To execute the instruction after it is shifted in, the TAP controller must be moved into the Update-IR state.

IDCODE

The IDCODE instruction loads a vendor-specific, 32 bit code into the instruction register. It also places the instruction register

between the TDI and TDO pins and shifts the IDCODE out of the device when the TAP controller enters the Shift-DR state. The IDCODE instruction is loaded into the instruction register at power up or whenever the TAP controller is supplied a Test-Logic-Reset state.

SAMPLE Z

The SAMPLE Z instruction connects the boundary scan register between the TDI and TDO pins when the TAP controller is in a Shift-DR state. The SAMPLE Z command puts the output bus into a High Z state until the next command is supplied during the Update IR state.

SAMPLE/PRELOAD

SAMPLE/PRELOAD is a 1149.1 mandatory instruction. When the SAMPLE/PRELOAD instructions are loaded into the instruction register and the TAP controller is in the Capture-DR state, a snapshot of data on the input and output pins is captured in the boundary scan register.

The user must be aware that the TAP controller clock can only operate at a frequency up to 20 MHz, while the SRAM clock operates more than an order of magnitude faster. Because there is a large difference in the clock frequencies, it is possible that during the Capture-DR state, an input or output undergoes a transition. The TAP may then try to capture a signal while in transition (metastable state). This does not harm the device, but there is no guarantee as to the value that is captured. Repeatable results may not be possible.

To guarantee that the boundary scan register captures the correct value of a signal, the SRAM signal must be stabilized long enough to meet the TAP controller's capture setup plus hold times (t_{CS} and t_{CH}). The SRAM clock input might not be captured correctly if there is no way in a design to stop (or slow) the clock during a SAMPLE/PRELOAD instruction. If this is an issue, it is still possible to capture all other signals and simply ignore the value of the CK and \overline{CK} captured in the boundary scan register.

After the data is captured, it is possible to shift out the data by putting the TAP into the Shift-DR state. This places the boundary scan register between the TDI and TDO pins.

PRELOAD places an initial data pattern at the latched parallel outputs of the boundary scan register cells before the selection of another boundary scan test operation.

The shifting of data for the SAMPLE and PRELOAD phases can occur concurrently when required, that is, while the data captured is shifted out, the preloaded data can be shifted in.

BYPASS

When the BYPASS instruction is loaded in the instruction register and the TAP is placed in a Shift-DR state, the bypass register is placed between the TDI and TDO pins. The advantage of the BYPASS instruction is that it shortens the boundary scan path when multiple devices are connected together on a board.

EXTEST

The EXTEST instruction drives the preloaded data out through the system output pins. This instruction also connects the boundary scan register for serial access between the TDI and TDO in the Shift-DR controller state.

EXTEST OUTPUT BUS TRI-STATE

IEEE Standard 1149.1 mandates that the TAP controller be able to put the output bus into a tri-state mode.

The boundary scan register has a special bit located at bit #108. When this scan cell, called the "extest output bus tri-state," is latched into the preload register during the Update-DR state in the TAP controller, it directly controls the state of the output (Q-bus) pins, when the EXTEST is entered as the current instruction. When HIGH, it enables the output buffers to drive the output bus. When LOW, this bit places the output bus into a High Z condition.

This bit can be set by entering the SAMPLE/PRELOAD or EXTEST command, and then shifting the desired bit into that cell, during the Shift-DR state. During Update-DR, the value loaded into that shift-register cell latches into the preload register. When the EXTEST instruction is entered, this bit directly controls the output Q-bus pins. Note that this bit is preset HIGH to enable the output when the device is powered up, and also when the TAP controller is in the Test-Logic-Reset state.

Reserved

These instructions are not implemented but are reserved for future use. Do not use these instructions.

TAP Controller State Diagram

The state diagram for the TAP controller follows. ^[9]

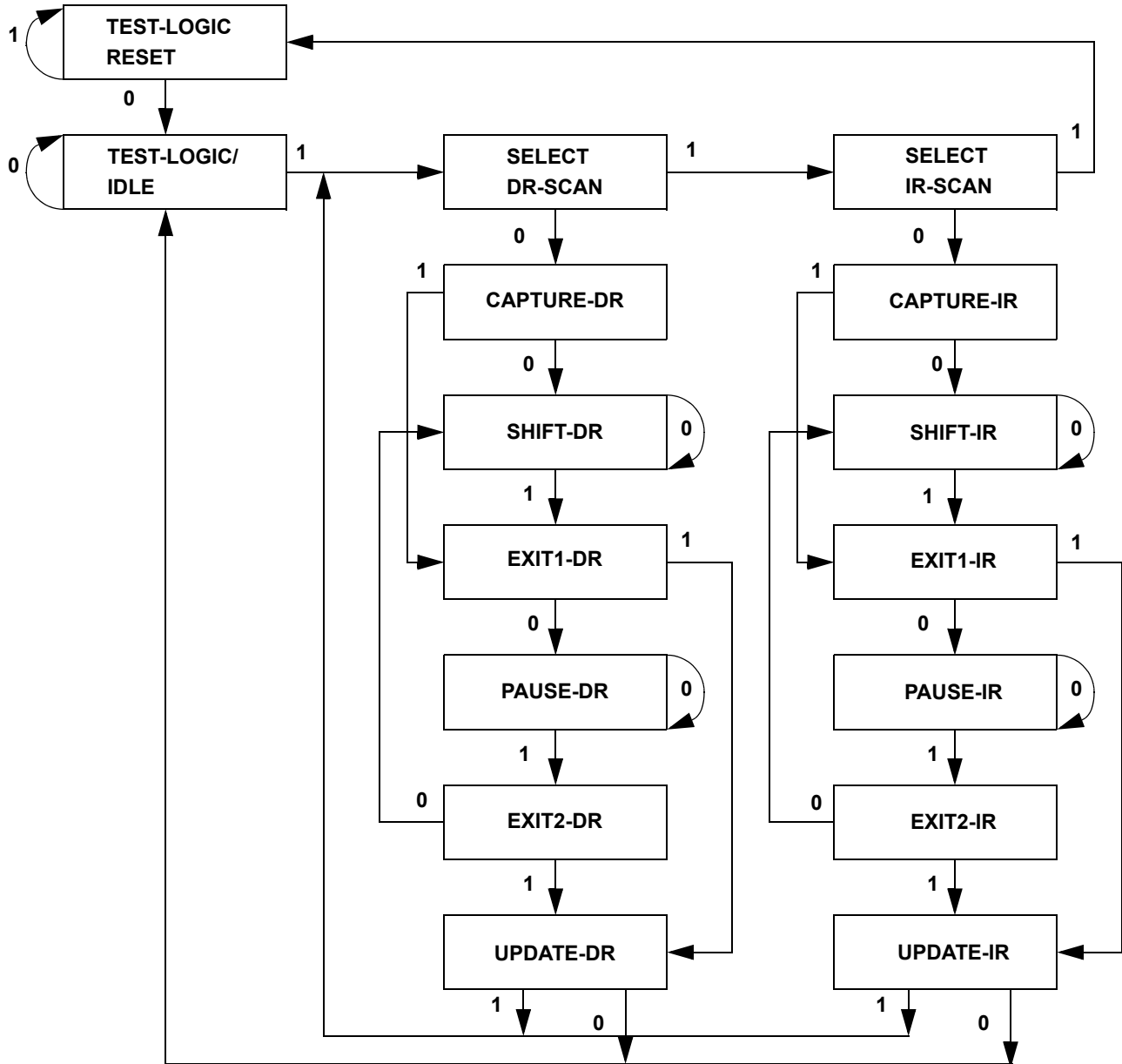

Note

9. The 0/1 next to each state represents the value at TMS at the rising edge of TCK.

TAP Controller Block Diagram

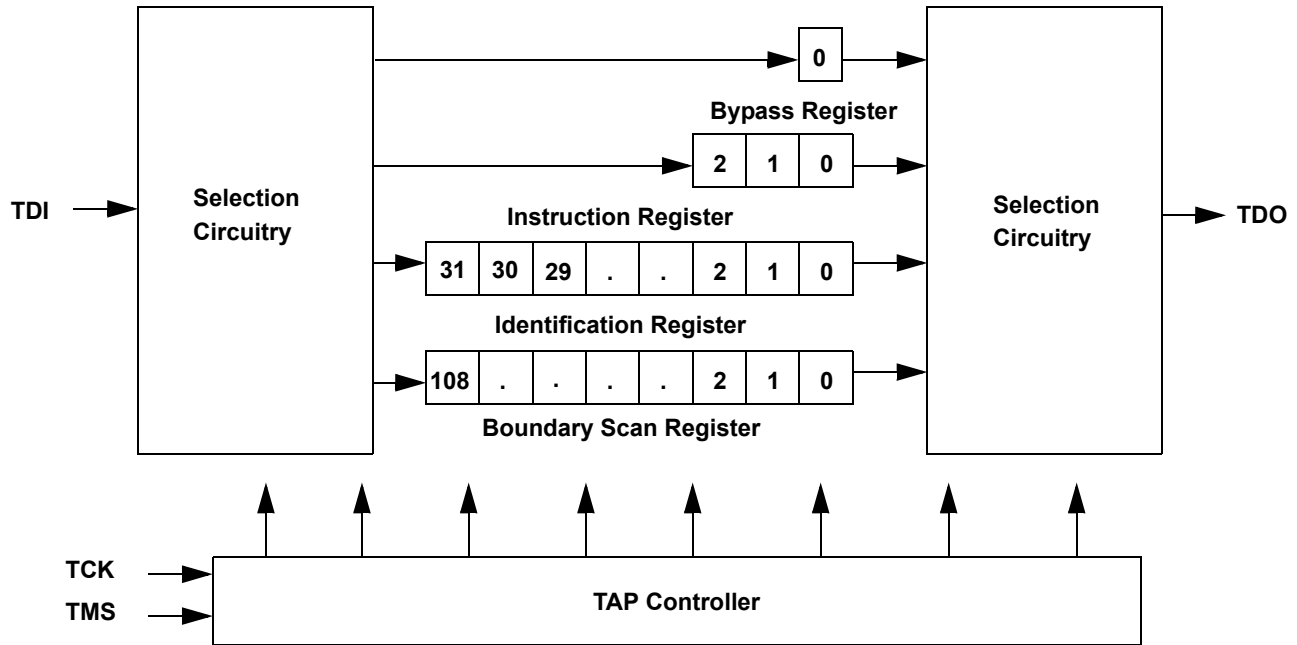

TAP Electrical Characteristics

Over the Operating Range [10, 11, 12]

Parameter	Description	Test Conditions	Min	Max	Unit
V _{OH1}	Output HIGH Voltage	I _{OH} = -2.0 mA	1.4		V
V _{OH2}	Output HIGH Voltage	I _{OH} = -100 μA	1.6		V
V _{OL1}	Output LOW Voltage	I _{OL} = 2.0 mA		0.4	V
V _{OL2}	Output LOW Voltage	I _{OL} = 100 μA		0.2	V
V _{IH}	Input HIGH Voltage		0.65V _{DD}	V _{DD} + 0.3	V
V _{IL}	Input LOW Voltage		-0.3	0.35V _{DD}	V
I _X	Input and Output Load Current	GND ≤ V _I ≤ V _{DD}	-5	5	μA

Notes

10. These characteristics pertain to the TAP inputs (TMS, TCK, TDI and TDO). Parallel load levels are specified in the [Electrical Characteristics Table](#).
11. Overshoot: V_{IH(AC)} < V_{DDQ} + 0.85V (Pulse width less than t_{CYC/2}), Undershoot: V_{IL(AC)} > -1.5V (Pulse width less than t_{CYC/2}).
12. All Voltage referenced to Ground.

TAP AC Switching Characteristics

Over the Operating Range [13, 14]

Parameter	Description	Min	Max	Unit
t_{TCYC}	TCK Clock Cycle Time	50		ns
t_{TF}	TCK Clock Frequency		20	MHz
t_{TH}	TCK Clock HIGH	20		ns
t_{TL}	TCK Clock LOW	20		ns
Setup Times				
t_{TMSS}	TMS Setup to TCK Clock Rise	5		ns
t_{TDIS}	TDI Setup to TCK Clock Rise	5		ns
t_{CS}	Capture Setup to TCK Rise	5		ns
Hold Times				
t_{TMSH}	TMS Hold after TCK Clock Rise	5		ns
t_{TDIH}	TDI Hold after Clock Rise	5		ns
t_{CH}	Capture Hold after Clock Rise	5		ns
Output Times				
t_{TDOV}	TCK Clock LOW to TDO Valid		10	ns
t_{TDOX}	TCK Clock LOW to TDO Invalid	0		ns

TAP Timing and Test Conditions

Figure 2 shows the TAP timing and test conditions. [14]

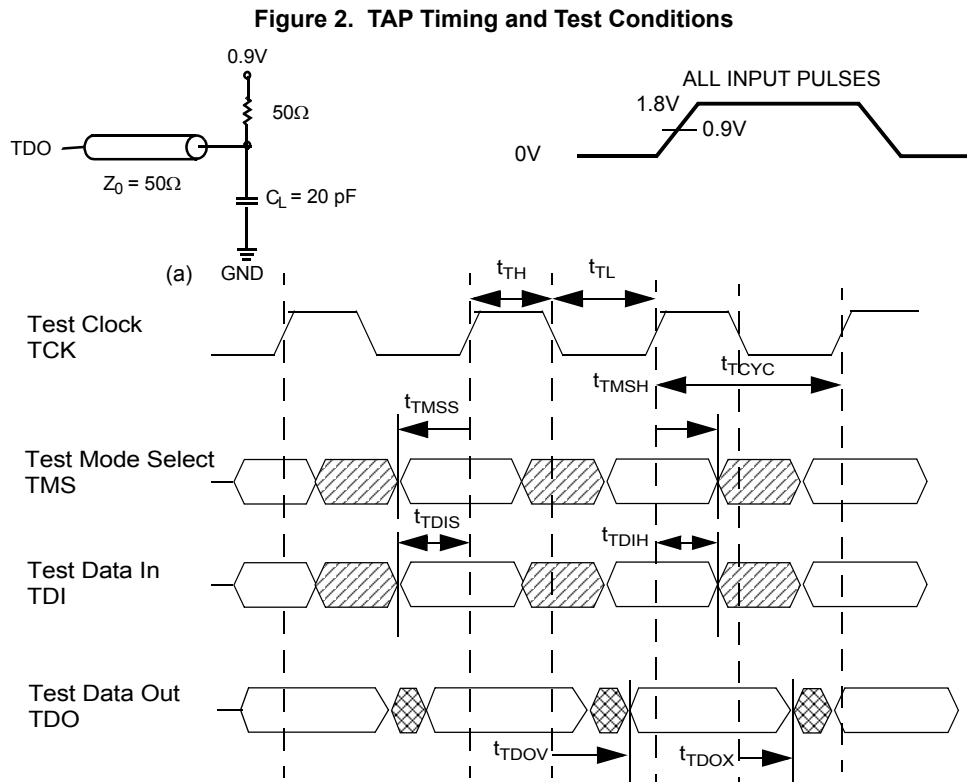

Notes

- t_{CS} and t_{CH} refer to the setup and hold time requirements of latching data from the boundary scan register.
- Test conditions are specified using the load in TAP AC Test Conditions. $t_R/t_F = 1\text{ ns}$.

Identification Register Definitions

Instruction Field	Value				Description
	CY7C1416AV18	CY7C1427AV18	CY7C1418AV18	CY7C1420AV18	
Revision Number (31:29)	000	000	000	000	Version number.
Cypress Device ID (28:12)	11010100010000111	11010100010001111	11010100010010111	11010100010100111	Defines the type of SRAM.
Cypress JEDEC ID (11:1)	00000110100	00000110100	00000110100	00000110100	Allows unique identification of SRAM vendor.
ID Register Presence (0)	1	1	1	1	Indicates the presence of an ID register.

Scan Register Sizes

Register Name	Bit Size
Instruction	3
Bypass	1
ID	32
Boundary Scan	109

Instruction Codes

Instruction	Code	Description
EXTEST	000	Captures the input and output ring contents.
IDCODE	001	Loads the ID register with the vendor ID code and places the register between TDI and TDO. This operation does not affect SRAM operation.
SAMPLE Z	010	Captures the input and output contents. Places the boundary scan register between TDI and TDO. Forces all SRAM output drivers to a High Z state.
RESERVED	011	Do Not Use: This instruction is reserved for future use.
SAMPLE/PRELOAD	100	Captures the input and output ring contents. Places the boundary scan register between TDI and TDO. Does not affect the SRAM operation.
RESERVED	101	Do Not Use: This instruction is reserved for future use.
RESERVED	110	Do Not Use: This instruction is reserved for future use.
BYPASS	111	Places the bypass register between TDI and TDO. This operation does not affect SRAM operation.

Boundary Scan Order

Bit #	Bump ID
0	6R
1	6P
2	6N
3	7P
4	7N
5	7R
6	8R
7	8P
8	9R
9	11P
10	10P
11	10N
12	9P
13	10M
14	11N
15	9M
16	9N
17	11L
18	11M
19	9L
20	10L
21	11K
22	10K
23	9J
24	9K
25	10J
26	11J
27	11H

Bit #	Bump ID
28	10G
29	9G
30	11F
31	11G
32	9F
33	10F
34	11E
35	10E
36	10D
37	9E
38	10C
39	11D
40	9C
41	9D
42	11B
43	11C
44	9B
45	10B
46	11A
47	10A
48	9A
49	8B
50	7C
51	6C
52	8A
53	7A
54	7B
55	6B

Bit #	Bump ID
56	6A
57	5B
58	5A
59	4A
60	5C
61	4B
62	3A
63	2A
64	1A
65	2B
66	3B
67	1C
68	1B
69	3D
70	3C
71	1D
72	2C
73	3E
74	2D
75	2E
76	1E
77	2F
78	3F
79	1G
80	1F
81	3G
82	2G
83	1H

Bit #	Bump ID
84	1J
85	2J
86	3K
87	3J
88	2K
89	1K
90	2L
91	3L
92	1M
93	1L
94	3N
95	3M
96	1N
97	2M
98	3P
99	2N
100	2P
101	1P
102	3R
103	4R
104	4P
105	5P
106	5N
107	5R
108	Internal

Power Up Sequence in DDR II SRAM

DDR II SRAMs must be powered up and initialized in a predefined manner to prevent undefined operations.

Power Up Sequence

- Apply power and drive $\overline{\text{DOFF}}$ either HIGH or LOW (All other inputs can be HIGH or LOW).
 - Apply V_{DD} before V_{DDQ} .
 - Apply V_{DDQ} before V_{REF} or at the same time as V_{REF} .
 - Drive $\overline{\text{DOFF}}$ HIGH.
- Provide stable $\overline{\text{DOFF}}$ (HIGH), power and clock (K, $\overline{\text{K}}$) for 1024 cycles to lock the DLL.

DLL Constraints

- DLL uses K clock as its synchronizing input. The input must have low phase jitter, which is specified as $t_{\text{KC Var}}$.
- The DLL functions at frequencies down to 120 MHz.
- If the input clock is unstable and the DLL is enabled, then the DLL may lock onto an incorrect frequency, causing unstable SRAM behavior. To avoid this, provide 1024 cycles stable clock to relock to the desired clock frequency.

Figure 3. Power Up Waveforms

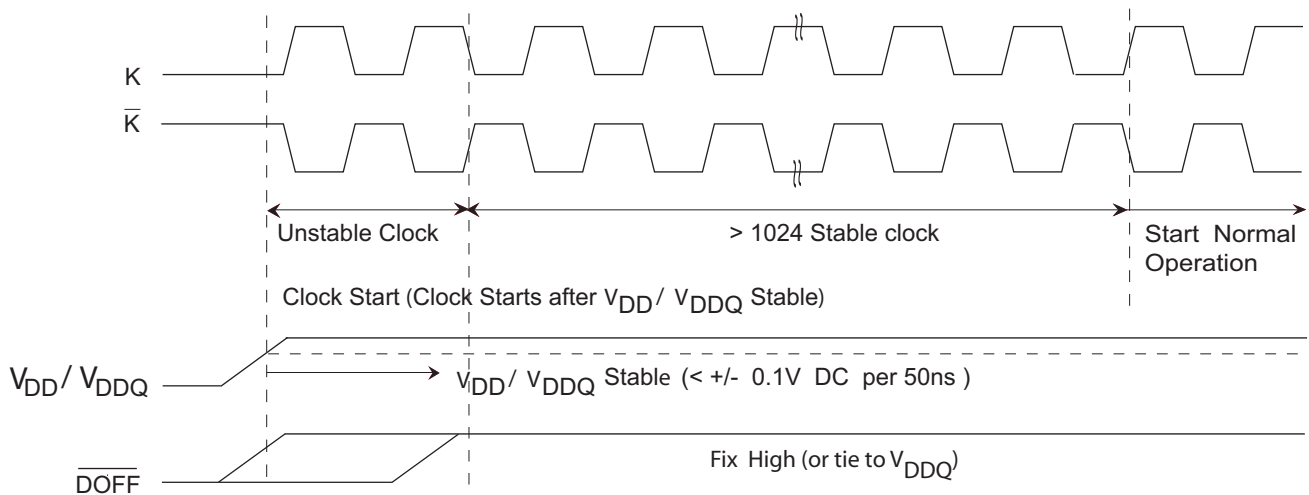

Maximum Ratings

Exceeding maximum ratings may impair the useful life of the device. These user guidelines are not tested.

Storage Temperature -65°C to +150°C
 Ambient Temperature with Power Applied -55°C to +125°C
 Supply Voltage on V_{DD} Relative to GND -0.5V to +2.9V
 Supply Voltage on V_{DDQ} Relative to GND -0.5V to +V_{DD}
 DC Applied to Outputs in High Z -0.5V to V_{DDQ} + 0.3V
 DC Input Voltage ^[11] -0.5V to V_{DD} + 0.3V
 Current into Outputs (LOW) 20 mA
 Static Discharge Voltage (MIL-STD-883, M 3015).... >2001V
 Latch up Current >200 mA

Operating Range

Range	Ambient Temperature (T _A)	V _{DD} ^[15]	V _{DDQ} ^[15]
Commercial	0°C to +70°C	1.8 ± 0.1V	1.4V to V _{DD}
Industrial	-40°C to +85°C		

Electrical Characteristics

DC Electrical Characteristics

Over the Operating Range ^[12]

Parameter	Description	Test Conditions	Min	Typ	Max	Unit	
V _{DD}	Power Supply Voltage		1.7	1.8	1.9	V	
V _{DDQ}	IO Supply Voltage		1.4	1.5	V _{DD}	V	
V _{OH}	Output HIGH Voltage	Note 16	V _{DDQ} /2 - 0.12		V _{DDQ} /2 + 0.12	V	
V _{OL}	Output LOW Voltage	Note 17	V _{DDQ} /2 - 0.12		V _{DDQ} /2 + 0.12	V	
V _{OH(LOW)}	Output HIGH Voltage	I _{OH} = -0.1 mA, Nominal Impedance	V _{DDQ} - 0.2		V _{DDQ}	V	
V _{OL(LOW)}	Output LOW Voltage	I _{OL} = 0.1 mA, Nominal Impedance	V _{SS}		0.2	V	
V _{IH}	Input HIGH Voltage		V _{REF} + 0.1		V _{DDQ} + 0.3	V	
V _{IL}	Input LOW Voltage		-0.3		V _{REF} - 0.1	V	
I _X	Input Leakage Current	GND ≤ V _I ≤ V _{DDQ}	-5		5	μA	
I _{OZ}	Output Leakage Current	GND ≤ V _I ≤ V _{DDQ} , Output Disabled	-5		5	μA	
V _{REF}	Input Reference Voltage ^[18]	Typical Value = 0.75V	0.68	0.75	0.95	V	
I _{DD} ^[19]	V _{DD} Operating Supply	V _{DD} = Max, I _{OUT} = 0 mA, f = f _{MAX} = 1/t _{CYC}	300MHz	(x18)		900	mA
				(x36)		990	
			278MHz	(x18)		835	
				(x36)		910	
			250MHz	(x18)		760	
				(x36)		825	

Notes

15. Power up: assumes a linear ramp from 0V to V_{DD}(min) within 200 ms. During this time V_{IH} < V_{DD} and V_{DDQ} ≤ V_{DD}.
16. Outputs are impedance controlled. I_{OH} = -(V_{DDQ}/2)/(RQ/5) for values of 175Ω ≤ RQ ≤ 350Ω.
17. Outputs are impedance controlled. I_{OL} = (V_{DDQ}/2)/(RQ/5) for values of 175Ω ≤ RQ ≤ 350Ω.
18. V_{REF}(min) = 0.68V or 0.46V_{DDQ}, whichever is larger, V_{REF}(max) = 0.95V or 0.54V_{DDQ}, whichever is smaller.
19. The operation current is calculated with 50% read cycle and 50% write cycle.

Neutron Soft Error Immunity

Parameter	Description	Test Conditions	Typ	Max*	Unit
LSBU	Logical Single Bit Upsets	25°C	320	368	FIT/Mb
LMBU	Logical Multi Bit Upsets	25°C	0	0.01	FIT/Mb
SEL	Single Event Latch up	85°C	0	0.1	FIT/Dev

* No LMBU, or SEL events occurred during testing; this column represents a statistical χ^2 , 95% confidence limit calculation. For more details refer to Application Note AN 54908 "Accelerated Neutron SER Testing and Calculation of Terrestrial Failure Rates"

Electrical Characteristics (continued)

DC Electrical Characteristics

Over the Operating Range ^[12]

Parameter	Description	Test Conditions	Min	Typ	Max	Unit	
I _{DD} ^[19]	V _{DD} Operating Supply	V _{DD} = Max, I _{OUT} = 0 mA, f = f _{MAX} = 1/t _{CYC}	200MHz	(x18)		620	mA
				(x36)		675	
			167MHz	(x18)		525	
				(x36)		570	
I _{SB1}	Automatic Power down Current	Max V _{DD} , Both Ports Deselected, V _{IN} ≥ V _{IH} or V _{IN} ≤ V _{IL} f = f _{MAX} = 1/t _{CYC} , Inputs Static	300MHz	(x18)		360	mA
				(x36)		400	
			278MHz	(x18)		345	
				(x36)		370	
			250MHz	(x18)		330	
				(x36)		350	
			200MHz	(x18)		300	
				(x36)		315	
167MHz	(x18)		290				
	(x36)		300				

AC Electrical Characteristics

Over the Operating Range ^[11]

Parameter	Description	Test Conditions	Min	Typ	Max	Unit
V _{IH}	Input HIGH Voltage		V _{REF} + 0.2	–	–	V
V _{IL}	Input LOW Voltage		–	–	V _{REF} – 0.2	V

Capacitance

Tested initially and after any design or process change that may affect these parameters.

Parameter	Description	Test Conditions	Max	Unit
C_{IN}	Input Capacitance	$T_A = 25^\circ\text{C}$, $f = 1\text{ MHz}$, $V_{DD} = 1.8\text{V}$, $V_{DDQ} = 1.5\text{V}$	5	pF
C_{CLK}	Clock Input Capacitance		4	pF
C_O	Output Capacitance		5	pF

Thermal Resistance

Tested initially and after any design or process change that may affect these parameters.

Parameter	Description	Test Conditions	165 FBGA Package	Unit
Θ_{JA}	Thermal Resistance (Junction to Ambient)	Test conditions follow standard test methods and procedures for measuring thermal impedance, in accordance with EIA/JESD51.	17.2	$^\circ\text{C/W}$
Θ_{JC}	Thermal Resistance (Junction to Case)		3.2	$^\circ\text{C/W}$

Figure 4. AC Test Loads and Waveforms

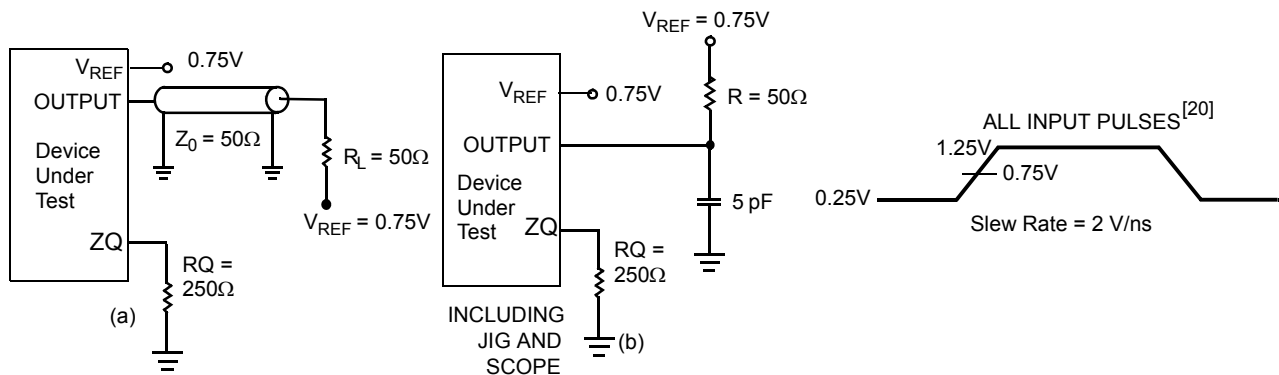

Note

20. Unless otherwise noted, test conditions assume signal transition time of 2V/ns, timing reference levels of 0.75V, $V_{REF} = 0.75\text{V}$, $R_Q = 250\Omega$, $V_{DDQ} = 1.5\text{V}$, input pulse levels of 0.25V to 1.25V, and output loading of the specified I_{OL}/I_{OH} and load capacitance shown in (a) of [AC Test Loads and Waveforms](#).

Switching Characteristics

Over the Operating Range [20, 21]

Cypress Parameter	Consortium Parameter	Description	300 MHz		278 MHz		250 MHz		200 MHz		167 MHz		Unit
			Min	Max	Min	Max	Min	Max	Min	Max	Min	Max	
t_{POWER}		V_{DD} (Typical) to the First Access [22]	1	–	1	–	1	–	1	–	1	–	ms
t_{CYC}	t_{KHKH}	K Clock and C Clock Cycle Time	3.3	8.4	3.6	8.4	4.0	8.4	5.0	8.4	6.0	8.4	ns
t_{KH}	t_{KHKL}	Input Clock (K/K and C/C) HIGH	1.32	–	1.4	–	1.6	–	2.0	–	2.4	–	ns
t_{KL}	t_{KLKH}	Input Clock (K/K and C/C) LOW	1.32	–	1.4	–	1.6	–	2.0	–	2.4	–	ns
$t_{KH\bar{K}H}$	$t_{KH\bar{K}H}$	K Clock Rise to K Clock Rise and C to C Rise (rising edge to rising edge)	1.49	–	1.6	–	1.8	–	2.2	–	2.7	–	ns
t_{KHCH}	t_{KHCH}	K/K Clock Rise to C/C Clock Rise (rising edge to rising edge)	0.0	1.45	0.0	1.55	0.0	1.8	0.0	2.2	0.0	2.7	ns
Setup Times													
t_{SA}	t_{AVKH}	Address Setup to K Clock Rise	0.4	–	0.4	–	0.5	–	0.6	–	0.7	–	ns
t_{SC}	t_{VVKH}	Control Setup to K Clock Rise (LD, R/W)	0.4	–	0.4	–	0.5	–	0.6	–	0.7	–	ns
t_{SCDDR}	t_{VVKH}	Double Data Rate Control Setup to Clock (K/K) Rise (BWS ₀ , BWS ₁ , BWS ₂ , BWS ₃)	0.3	–	0.3	–	0.35	–	0.4	–	0.5	–	ns
t_{SD}	t_{DVKH}	D _[X:0] Setup to Clock (K/K) Rise	0.3	–	0.3	–	0.35	–	0.4	–	0.5	–	ns
Hold Times													
t_{HA}	t_{KHAX}	Address Hold after K Clock Rise	0.4	–	0.4	–	0.5	–	0.6	–	0.7	–	ns
t_{HC}	t_{KHIX}	Control Hold after K Clock Rise (LD, R/W)	0.4	–	0.4	–	0.5	–	0.6	–	0.7	–	ns
t_{HCDDR}	t_{KHIX}	Double Data Rate Control Hold after Clock (K/K) Rise (BWS ₀ , BWS ₁ , BWS ₂ , BWS ₃)	0.3	–	0.3	–	0.35	–	0.4	–	0.5	–	ns
t_{HD}	t_{KHDX}	D _[X:0] Hold after Clock (K/K) Rise	0.3	–	0.3	–	0.35	–	0.4	–	0.5	–	ns

Notes

21. When a part with a maximum frequency above 167 MHz is operating at a lower clock frequency, it requires the input timings of the frequency range in which it is being operated and outputs data with the output timings of that frequency range.

22. This part has an internal voltage regulator; t_{POWER} is the time that the power is supplied above V_{DD} min initially before a read or write operation can be initiated.

Switching Characteristics (continued)

Over the Operating Range [20, 21]

Cypress Parameter	Consortium Parameter	Description	300 MHz		278 MHz		250 MHz		200 MHz		167 MHz		Unit
			Min	Max	Min	Max	Min	Max	Min	Max	Min	Max	
Output Times													
t _{CO}	t _{CHQV}	C/C Clock Rise (or K/K in single clock mode) to Data Valid	–	0.45	–	0.45	–	0.45	–	0.45	–	0.50	ns
t _{DOH}	t _{CHQX}	Data Output Hold after Output C/C Clock Rise (Active to Active)	–0.45	–	–0.45	–	–0.45	–	–0.45	–	–0.50	–	ns
t _{CCQO}	t _{CHCQV}	C/C Clock Rise to Echo Clock Valid	–	0.45	–	0.45	–	0.45	–	0.45	–	0.50	ns
t _{CQOH}	t _{CHCQX}	Echo Clock Hold after C/C Clock Rise	–0.45	–	–0.45	–	–0.45	–	–0.45	–	–0.50	–	ns
t _{CQD}	t _{CQHQV}	Echo Clock High to Data Valid	–	0.27	–	0.27	–	0.30	–	0.35	–	0.40	ns
t _{CQDOH}	t _{CQHQX}	Echo Clock High to Data Invalid	–0.27	–	–0.27	–	–0.30	–	–0.35	–	–0.40	–	ns
t _{CHZ}	t _{CHQZ}	Clock (C/C) Rise to High Z (Active to High Z) [23, 24]	–	0.45	–	0.45	–	0.45	–	0.45	–	0.50	ns
t _{CLZ}	t _{CHQX1}	Clock (C/C) Rise to Low Z [23, 24]	–0.45	–	–0.45	–	–0.45	–	–0.45	–	–0.50	–	ns
DLL Timing													
t _{KC Var}	t _{KC Var}	Clock Phase Jitter	–	0.20	–	0.20	–	0.20	–	0.20	–	0.20	ns
t _{KC lock}	t _{KC lock}	DLL Lock Time (K, C)	1024	–	1024	–	1024	–	1024	–	1024	–	Cycles
t _{KC Reset}	t _{KC Reset}	K Static to DLL Reset	30	–	30	–	30	–	30	–	30	–	ns

Notes

23. t_{CHZ}, t_{CLZ} are specified with a load capacitance of 5 pF as in (b) of [AC Test Loads and Waveforms](#) on page 20. Transition is measured ±100 mV from steady-state voltage.
24. At any voltage and temperature t_{CHZ} is less than t_{CLZ} and t_{CHZ} less than t_{CO}.

Switching Waveforms

Figure 5. Read/Write/Deselect Sequence [25, 26, 27]

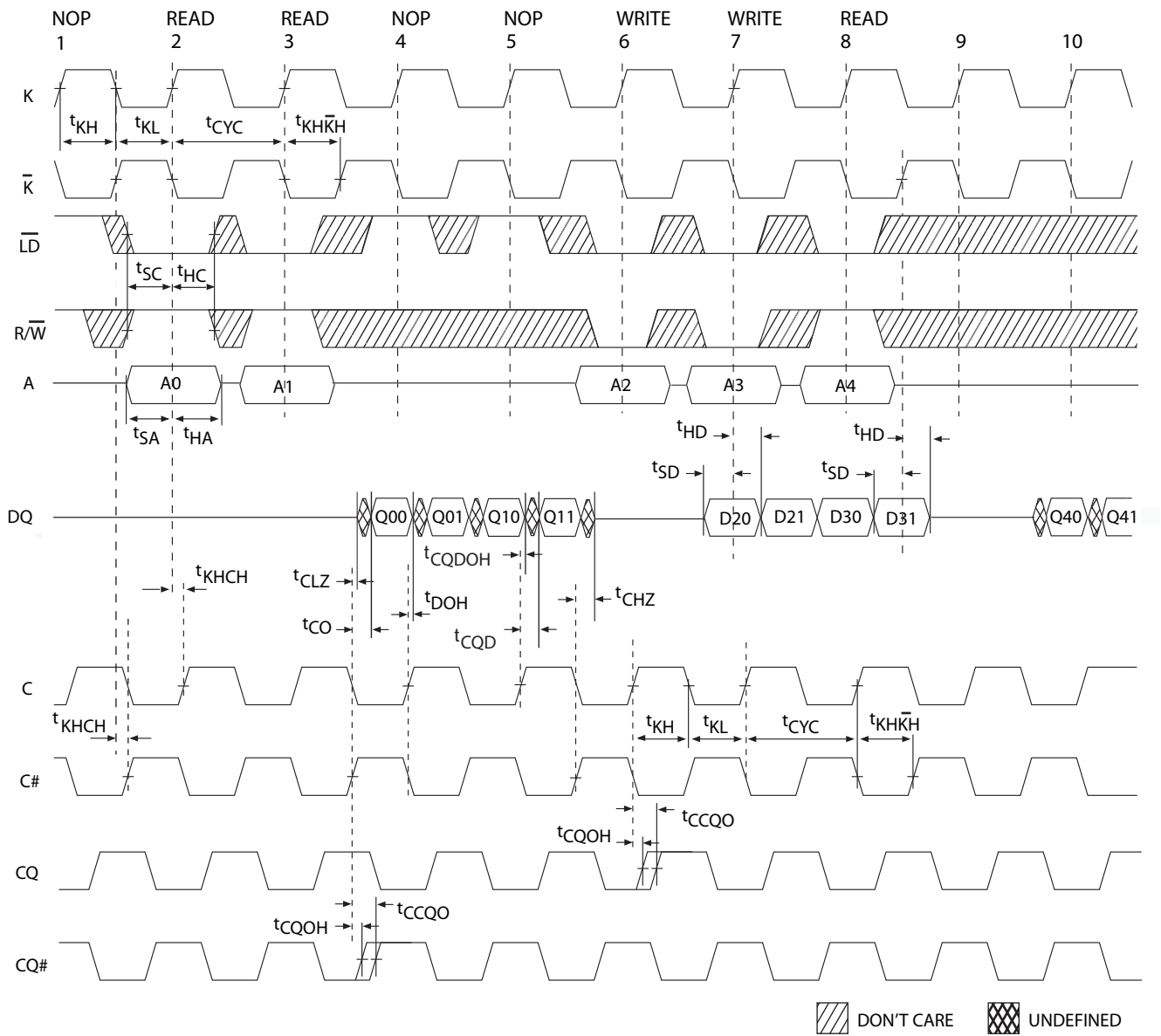

Notes

- 25. Q00 refers to output from address A0. Q01 refers to output from the next internal burst address following A0, that is, A0 + 1.
- 26. Outputs are disabled (High Z) one clock cycle after a NOP.
- 27. In this example, if address A4 = A3, then data Q40 = D30 and Q41 = D31. Write data is forwarded immediately as read results. This note applies to the whole diagram.

Ordering Information

Cypress offers other versions of this type of product in many different configurations and features. The below table contains only the list of parts that are currently available. For a complete listing of all options, visit the Cypress website at www.cypress.com and refer to the product summary page at <http://www.cypress.com/products> or contact your local sales representative. Cypress maintains a worldwide network of offices, solution centers, manufacturer's representatives and distributors. To find the office closest to you, visit us at <http://www.cypress.com/go/datasheet/offices>.

Table 3. Ordering Information

Speed (MHz)	Ordering Code	Package Diagram	Package Type	Operating Range
267	CY7C1418AV18-267BZC	51-85195	165-Ball Fine Pitch Ball Grid Array (15 x 17 x 1.4 mm)	Commercial
	CY7C1418AV18-267BZXC		165-Ball Fine Pitch Ball Grid Array (15 x 17 x 1.4 mm) Pb-Free	
250	CY7C1418AV18-250BZC	51-85195	165-Ball Fine Pitch Ball Grid Array (15 x 17 x 1.4 mm)	Commercial
	CY7C1420AV18-250BZC			
200	CY7C1420AV18-200BZC	51-85195	165-Ball Fine Pitch Ball Grid Array (15 x 17 x 1.4 mm)	Commercial
167	CY7C1420AV18-167BZXC	51-85195	165-Ball Fine Pitch Ball Grid Array (15 x 17 x 1.4 mm) Pb-Free	Commercial

Ordering Code Definition

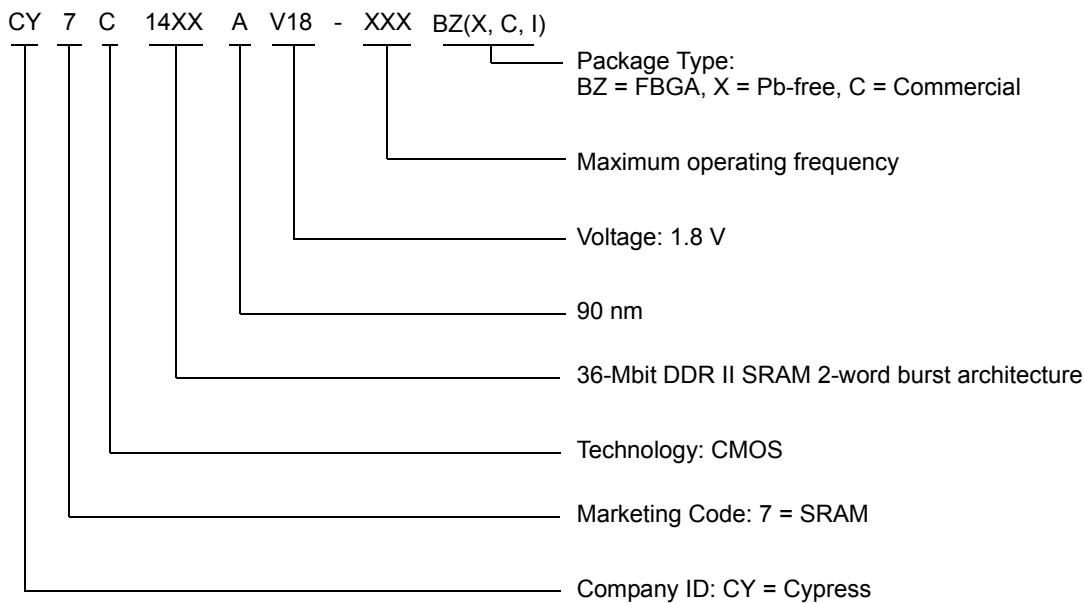

Package Diagram

Figure 6. 165-ball FBGA (15 x 17 x 1.4 mm)

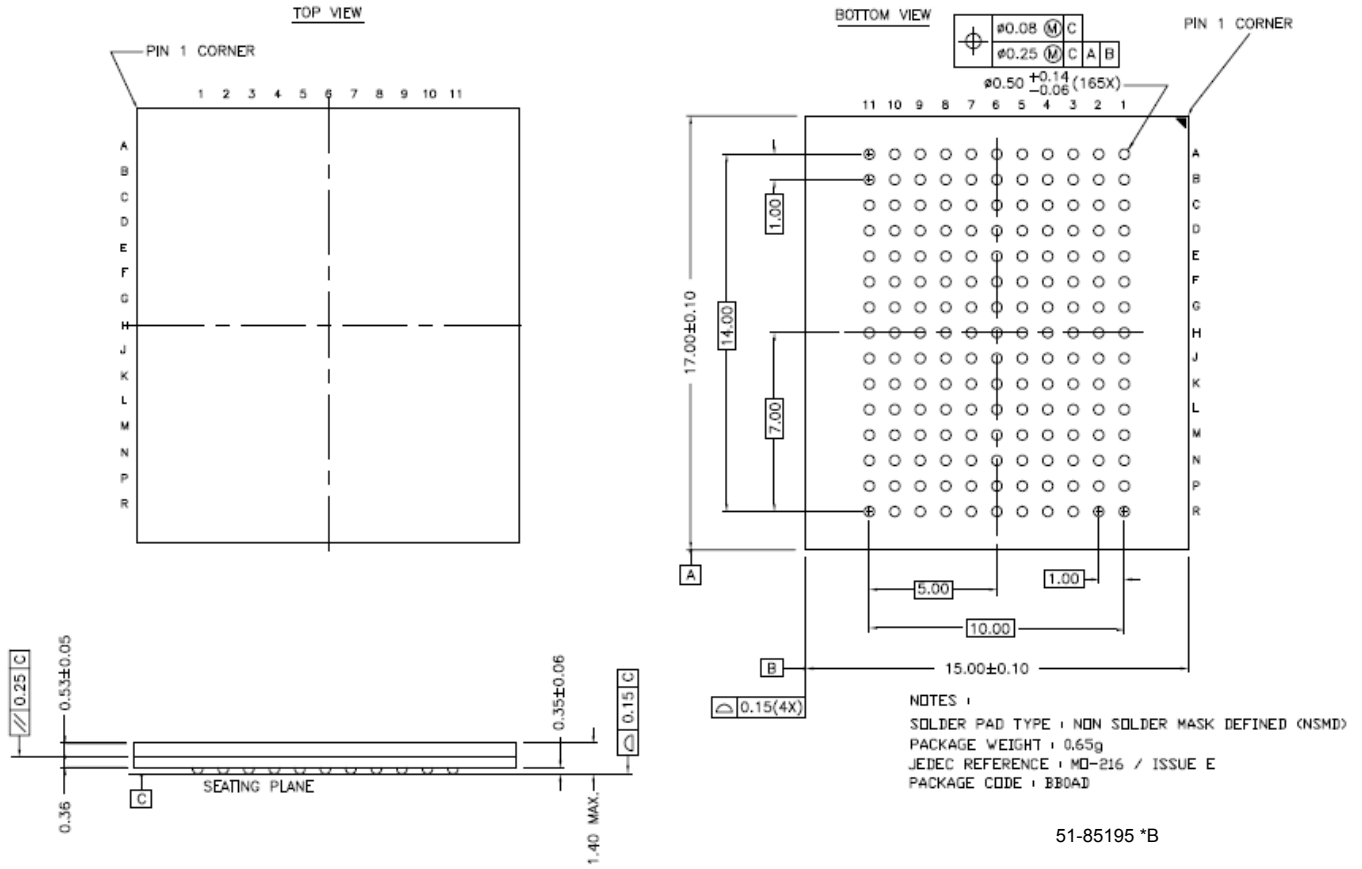

Document History Page

Document Title: CY7C1418AV18, CY7C1420AV18, 36 Mbit DDR II SRAM Two Word Burst Architecture Document Number: 38-05616				
Revision	ECN	Orig. Of Change	Submission Date	Description Of Change
**	247331	SYT	08/26/04	New Datasheet
*A	326519	SYT	04/14/05	Removed CY7C1420AV18 from the title Included 300 MHz Speed grade Replaced TBDs with their respective values for I_{DD} and I_{SB1} Added Industrial temperature grade Replaced the TBDs on the Thermal Characteristics Table to $\Theta_{JA} = 17.2^{\circ}\text{C/W}$ and $\Theta_{JC} = 3.2^{\circ}\text{C/W}$ Replaced TBDs in the Capacitance Table to their respective values for the 165 FBGA Package Changed typo of bit # 47 to bit # 108 under the EXTEST OUTPUT BUS TRI-STATE on Page 18 Added lead-free Product Information Updated the Ordering Information by Shading and Unshading MPNs as per availability
*B	413953	NXR	12/22/05	Converted from preliminary to final Added CY7C1427AV18 part number to title Added 278 MHz speed Bin Changed C, C Description in Feature Section and Pin Description Changed address of Cypress Semiconductor Corporation on Page# 1 from "3901 North First Street" to "198 Champion Court" Added Power Up sequence and Wave form on page# 19 Added Footnotes# 13, 14, 15 on page# 19 Replaced Three-state with Tri-state Changed the description of I_X from Input Load Current to Input Leakage Current on page# 20 Modified the I_{DD} and I_{SB} values Modified test condition in Footnote #17 on page# 20 from $V_{DDQ} < V_{DD}$ to $V_{DDQ} \leq V_{DD}$ Replaced Package Name column with Package Diagram in the Ordering Information table. Updated Ordering Information Table
*C	468029	NXR	07/10/06	Modified the ZQ Definition from Alternately, this pin can be connected directly to V_{DD} to Alternately, this pin can be connected directly to V_{DDQ} Included Maximum Ratings for Supply Voltage on V_{DDQ} Relative to GND Changed the Maximum Ratings for DC Input Voltage from V_{DDQ} to V_{DD} Changed t_{TH} and t_{TL} from 40 ns to 20 ns, changed t_{TMSS} , t_{TDIS} , t_{CS} , t_{TMSH} , t_{TDIH} , t_{CH} from 10 ns to 5 ns and changed t_{TDOV} from 20 ns to 10 ns in TAP AC Switching Characteristics table Modified Power Up waveform Changed the Maximum rating of Ambient Temperature with Power Applied from -10°C to $+85^{\circ}\text{C}$ to -55°C to $+125^{\circ}\text{C}$ Added additional notes in the AC parameter section Modified AC Switching Waveform Corrected the typo In the AC Switching Characteristics Table Updated the Ordering Information Table
*D	505682	VKN	12/19/06	Corrected typo in the Functional Description section for burst counter logic
*E	2511757	VKN/AESA	06/19/08	Updated Logic Block diagram Updated I_{DD}/I_{SB} specs Added footnote # 19 related to I_{DD} Updated Power Up sequence waveform and its description Changed DLL minimum operating frequency from 80 MHz to 120 MHz Changed t_{CYC} max spec to 8.4 ns for all speed bins Modified footnotes 21 and 28

Document History Page

Document Title: CY7C1418AV18, CY7C1420AV18, 36 Mbit DDR II SRAM Two Word Burst Architecture				
Document Number: 38-05616				
Revision	ECN	Org. of Change	Submission Date	Description of Change
*F	2648034	PYRS	01/29/09	Moved to external web
*G	2755901	VKN	08/25/09	Removed x8 and x9 part number details Included Soft Error Immunity Data Modified Ordering Information table by including parts that are available and modified the disclaimer for the Ordering information. Updated Package Diagram.
*H	2897120	03/22/2010	NJY	Removed inactive parts from Ordering Information table.
*I	3068494	10/21/2010	HMLA	Removed inactive part - CY7C1420AV18-278BZC, and active parts - CY7C1418AV18-267BZC, CY7C1418AV18-267BZXC in Ordering Information table. Added Ordering Code Definition.

Sales, Solutions, and Legal Information

Worldwide Sales and Design Support

Cypress maintains a worldwide network of offices, solution centers, manufacturer's representatives, and distributors. To find the office closest to you, visit us at cypress.com/sales.

Products

PSoC	psoc.cypress.com
Clocks & Buffers	clocks.cypress.com
Wireless	wireless.cypress.com
Memories	memory.cypress.com
Image Sensors	image.cypress.com

© Cypress Semiconductor Corporation, 2004-2010. The information contained herein is subject to change without notice. Cypress Semiconductor Corporation assumes no responsibility for the use of any circuitry other than circuitry embodied in a Cypress product. Nor does it convey or imply any license under patent or other rights. Cypress products are not warranted nor intended to be used for medical, life support, life saving, critical control or safety applications, unless pursuant to an express written agreement with Cypress. Furthermore, Cypress does not authorize its products for use as critical components in life-support systems where a malfunction or failure may reasonably be expected to result in significant injury to the user. The inclusion of Cypress products in life-support systems application implies that the manufacturer assumes all risk of such use and in doing so indemnifies Cypress against all charges.

Any Source Code (software and/or firmware) is owned by Cypress Semiconductor Corporation (Cypress) and is protected by and subject to worldwide patent protection (United States and foreign), United States copyright laws and international treaty provisions. Cypress hereby grants to licensee a personal, non-exclusive, non-transferable license to copy, use, modify, create derivative works of, and compile the Cypress Source Code and derivative works for the sole purpose of creating custom software and or firmware in support of licensee product to be used only in conjunction with a Cypress integrated circuit as specified in the applicable agreement. Any reproduction, modification, translation, compilation, or representation of this Source Code except as specified above is prohibited without the express written permission of Cypress.

Disclaimer: CYPRESS MAKES NO WARRANTY OF ANY KIND, EXPRESS OR IMPLIED, WITH REGARD TO THIS MATERIAL, INCLUDING, BUT NOT LIMITED TO, THE IMPLIED WARRANTIES OF MERCHANTABILITY AND FITNESS FOR A PARTICULAR PURPOSE. Cypress reserves the right to make changes without further notice to the materials described herein. Cypress does not assume any liability arising out of the application or use of any product or circuit described herein. Cypress does not authorize its products for use as critical components in life-support systems where a malfunction or failure may reasonably be expected to result in significant injury to the user. The inclusion of Cypress' product in a life-support systems application implies that the manufacturer assumes all risk of such use and in doing so indemnifies Cypress against all charges.

Use may be limited by and subject to the applicable Cypress software license agreement.

Looking for pricing, stock, or lifecycle information?

Click below to explore more details on WIN SOURCE:

- ⊖ [View CY7C1420AV18-250BZC on WIN SOURCE](#)
- ⊖ [Cypress Semiconductor Corp Information](#)

Optimize Your Supply Chain with WIN SOURCE Solutions

- ✓ Global Sourcing Solution
- ✓ Obsolete Management
- ✓ Cost Control Management
- ✓ Shortage Management
- ✓ Alternative Solution
- ✓ Excess Inventory Management