



THE DATASHEET OF STM802SM6E



TPS3851-Q1 High-Accuracy Voltage Supervisor with Integrated Watchdog Timer

1 Features

- AEC-Q100 qualified with the following results:
 - Device temperature grade 1: -40°C to 125°C ambient operating temperature range
 - Device HBM ESD classification level 2
 - Device CDM ESD classification level C4B
- Functional Safety-capable
 - Documentation available to aid functional safety system design
- Input voltage range: $V_{\text{DD}} = 1.6\text{ V}$ to 6.5 V
- 0.8% Voltage threshold accuracy
- Low supply current: $I_{\text{DD}} = 10\ \mu\text{A}$ (typical)
- User-programmable watchdog timeout
- Factory programmed precision watchdog and reset timers:
- Manual reset input ($\overline{\text{MR}}$)
- Open-drain outputs
- Precision undervoltage monitoring:
 - Supports common rails from 1.8 V to 5.0 V
 - 4% and 7% undervoltage thresholds available
 - 0.5% Hysteresis
- Watchdog disable feature
- Available in a small $3\text{-mm} \times 3\text{-mm}$, 8-Pin VSON package

2 Applications

- [Surround view system ECU](#)
- [Vehicle occupant detection sensor](#)
- [ADAS domain controller](#)
- [Automotive DC/DC Converter](#)
- [Automotive front camera](#)
- [Automotive center information display](#)

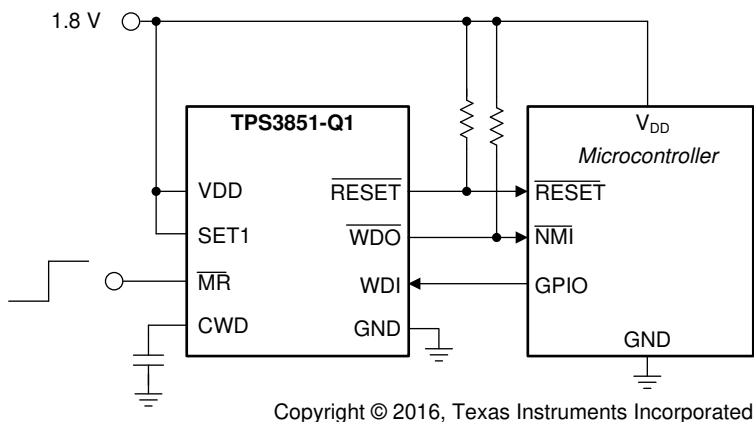

Fully Integrated Microcontroller Supervisory Circuit

3 Description

The TPS3851-Q1 device combines a precision voltage supervisor with a programmable watchdog timer. The TPS3851-Q1 comparator achieves a 0.8% accuracy (-40°C to $+125^{\circ}\text{C}$) for the undervoltage (V_{ITN}) threshold on the VDD pin. The TPS3851-Q1 also includes accurate hysteresis on the undervoltage threshold making the device ideal for use with tight tolerance systems. The supervisor $\overline{\text{RESET}}$ delay features a 15% accuracy, high-precision delay timing.

The TPS3851-Q1 includes a programmable watchdog timer for a wide variety of applications. The dedicated watchdog output ($\overline{\text{WDO}}$) enables increased resolution to help determine the nature of fault conditions. The watchdog timeouts can be programmed either by an external capacitor, or by factory-programmed default delay settings. The watchdog can be disabled via logic pins to avoid undesired watchdog timeouts during the development process.

The TPS3851-Q1 is available in a small $3.00\text{-mm} \times 3.00\text{-mm}$, 8-pin VSON package. The TPS3851-Q1 features wettable flanks that allow for easy optical inspection.

Device Information

PART NUMBER	PACKAGE (1)	BODY SIZE (NOM)
TPS3851-Q1	VSON (8)	3.00 mm \times 3.00 mm

- (1) For all available packages, see the orderable addendum at the end of the data sheet.

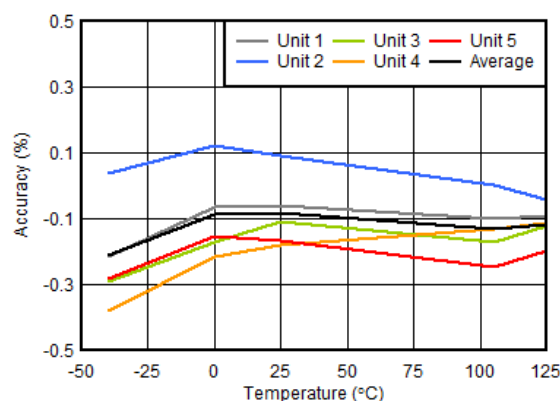

Undervoltage Threshold (V_{ITN}) Accuracy vs Temperature



Table of Contents

1 Features	1	7.4 Device Functional Modes.....	14
2 Applications	1	8 Application and Implementation	15
3 Description	1	8.1 Application Information.....	15
4 Revision History	2	8.2 Typical Application.....	18
5 Pin Configuration and Functions	3	9 Power Supply Recommendations	21
6 Specifications	4	10 Layout	22
6.1 Absolute Maximum Ratings.....	4	10.1 Layout Guidelines.....	22
6.2 ESD Ratings.....	4	10.2 Layout Example.....	22
6.3 Recommended Operating Conditions.....	4	11 Device and Documentation Support	23
6.4 Thermal Information.....	5	11.1 Device Support.....	23
6.5 Electrical Characteristics.....	5	11.2 Documentation Support.....	23
6.6 Timing Requirements.....	6	11.3 Receiving Notification of Documentation Updates..	23
6.7 Timing Diagrams.....	7	11.4 Support Resources.....	23
6.8 Typical Characteristics.....	8	11.5 Trademarks.....	23
7 Detailed Description	11	11.6 Electrostatic Discharge Caution.....	23
7.1 Overview.....	11	11.7 Glossary.....	23
7.2 Functional Block Diagram.....	11	12 Mechanical, Packaging, and Orderable Information	24
7.3 Feature Description.....	11		

4 Revision History

NOTE: Page numbers for previous revisions may differ from page numbers in the current version.

Changes from Revision * (March 2017) to Revision A (September 2021)

	Page
• Updated the numbering format for tables, figures, and cross-references throughout the document.....	1
• Removed "±15% Accurate Watchdog Timeout and Watchdog Reset Delays Over Temperature".....	1
• Added "Functional Safety-capable" bullet.....	1
• Updated the numbering format for tables, figures, and cross-references throughout the document.....	1
• Added "on the VDD pin" for clarification.....	1
• Updated ESD Ratings.....	4
• Updated I_{CWD} min and max spec.....	5
• Updated V_{CWD} min and max spec.....	5
• Added a footnote to for t_{INIT}	6
• Updated t_{WDU} min and max boundry values from 0.85 and 1.15 to 0.905 and 1.095 respectively.....	16
• Updated t_{WDU} min and max values for all capacitors.....	16
• Updated the equations 6 and 7 to replace 0.85 and 1.15 to 0.905 and 1.095 respectively.....	19

5 Pin Configuration and Functions

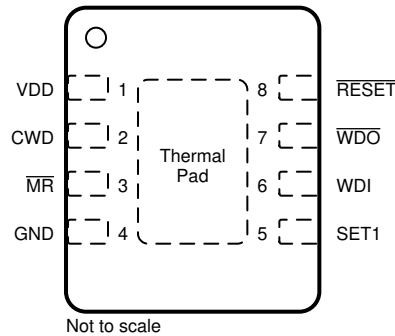

**Figure 5-1. DRB Package
3-mm × 3-mm, 8-Pin VSON
Top View**

Table 5-1. Pin Functions

NAME	NO.	I/O	DESCRIPTION
CWD	2	I	Programmable watchdog timeout input. The watchdog timeout is set by connecting a capacitor between this pin and ground. Connecting via a 10-kΩ resistor to V_{DD} or leaving unconnected further enables the selection of the preset watchdog timeouts; see the <i>CWD Functionality</i> section. The TPS3851-Q1 determines the watchdog timeout using either Equation 1 or Equation 2 with standard or extended timing, respectively.
GND	4	—	Ground pin
\overline{MR}	3	I	Manual reset pin. A logical low on this pin issues a \overline{RESET} . This pin is internally pulled up to V_{DD} . \overline{RESET} remains low for a fixed reset delay (t_{RST}) time after \overline{MR} is deasserted (high).
\overline{RESET}	8	O	Reset output. Connect \overline{RESET} using a 1-kΩ to 100-kΩ resistor to the correct pullup voltage rail (V_{PU}). \overline{RESET} goes low when V_{DD} goes below the undervoltage threshold (V_{ITN}). When V_{DD} is within the normal operating range, the \overline{RESET} timeout-counter starts. At completion, \overline{RESET} goes high. During startup, the state of \overline{RESET} is undefined below the specified power-on-reset (POR) voltage (V_{POR}). Above POR, \overline{RESET} goes low and remains low until the monitored voltage is within the correct operating range (above $V_{ITN} + V_{HYST}$) and the \overline{RESET} timeout is complete.
SET1	5	I	Logic input. Grounding the SET1 pin disables the watchdog timer. SET1 and CWD select the watchdog timeouts; see the SET1 section.
VDD	1	I	Supply voltage pin. For noisy systems, connecting a 0.1-μF bypass capacitor is recommended.
WDI	6	I	Watchdog input. A falling edge must occur at WDI before the timeout (t_{WD}) expires. When the watchdog is not in use, the SET1 pin can be used to disable the watchdog. WDI is ignored when \overline{RESET} or \overline{WDO} are low (asserted) and when the watchdog is disabled. If the watchdog is disabled, WDI cannot be left unconnected and must be driven to either VDD or GND.
\overline{WDO}	7	O	Watchdog output. Connect \overline{WDO} with a 1-kΩ to 100-kΩ resistor to the correct pullup voltage rail (V_{PU}). \overline{WDO} goes low (asserts) when a watchdog timeout occurs. \overline{WDO} only asserts when \overline{RESET} is high. When a watchdog timeout occurs, \overline{WDO} goes low (asserts) for the set \overline{RESET} timeout delay (t_{RST}). When \overline{RESET} goes low, \overline{WDO} is in a high-impedance state.
Thermal pad		—	Connect the thermal pad to a large-area ground plane. The thermal pad is internally connected to GND.

6 Specifications

6.1 Absolute Maximum Ratings

over operating free-air temperature range (unless otherwise noted) ⁽¹⁾

		MIN	MAX	UNIT
Supply voltage range	VDD	-0.3	7	V
Output voltage range	RESET, WDO	-0.3	7	V
Voltage ranges	SET1, WDI, MR	-0.3	7	V
	CWD	-0.3	V _{DD} + 0.3 ⁽³⁾	
Output pin current	RESET, WDO		±20	mA
Input current (all pins)			±20	mA
Continuous total power dissipation		See Section 6.4		
Temperature	Operating junction, T _J ⁽²⁾	-40	150	°C
	Operating free-air, T _A ⁽²⁾	-40	150	
	Storage, T _{stg}	-65	150	

(1) Stresses beyond those listed under *Absolute Maximum Ratings* may cause permanent damage to the device. These are stress ratings only, which do not imply functional operation of the device at these or any other conditions beyond those indicated under *Recommended Operating Conditions*. Exposure to absolute-maximum-rated conditions for extended periods may affect device reliability.

(2) Assume that T_J = T_A as a result of the low dissipated power in this device.

(3) The absolute maximum rating is V_{DD} + 0.3 V or 7.0 V, whichever is smaller.

6.2 ESD Ratings

		VALUE	UNIT
V _(ESD) Electrostatic discharge	Human-body model (HBM), per AEC Q100-002 ⁽¹⁾	±4000	V
	Charged-device model (CDM), per AEC Q100-011	±1000	

(1) AEC Q100-002 indicates that HBM stressing shall be in accordance with the ANSI/ESDA/JEDEC JS-001 specification.

6.3 Recommended Operating Conditions

over operating free-air temperature range (unless otherwise noted)

		MIN	TYP	MAX	UNIT
V _{DD}	Supply pin voltage	1.6		6.5	V
V _{SET1}	SET1 pin voltage	0		6.5	V
C _{CWD}	Watchdog timing capacitor	0.1 ⁽¹⁾ ⁽²⁾		1000 ⁽¹⁾ ⁽²⁾	nF
CWD	Pullup resistor to VDD	9	10	11	kΩ
R _{PU}	Pullup resistor, RESET and WDO	1	10	100	kΩ
I _{RESET}	RESET pin current			10	mA
I _{WDO}	Watchdog output current			10	mA
T _J	Junction temperature	-40		125	°C

(1) Using standard timing with a C_{CWD} capacitor of 0.1 nF or 1000 nF gives a t_{WD(typ)} of 0.704 ms or 3.23 seconds, respectively.

(2) Using extended timing with a C_{CWD} capacitor of 0.1 nF or 1000 nF gives a t_{WD(typ)} of 62.74 ms or 77.45 seconds, respectively.

6.4 Thermal Information

THERMAL METRIC ⁽¹⁾		TPS3851-Q1	UNIT
		DRB (VSON)	
		8 PINS	
R _{θJA}	Junction-to-ambient thermal resistance	47.7	°C/W
R _{θJC(top)}	Junction-to-case (top) thermal resistance	51.5	°C/W
R _{θJB}	Junction-to-board thermal resistance	22.2	°C/W
ψ _{JT}	Junction-to-top characterization parameter	1.3	°C/W
ψ _{JB}	Junction-to-board characterization parameter	22.3	°C/W
R _{θJC(bot)}	Junction-to-case (bottom) thermal resistance	4.3	°C/W

(1) For more information about traditional and new thermal metrics, see the [Semiconductor and IC Package Thermal Metrics](#) application report.

6.5 Electrical Characteristics

at $V_{ITN} + V_{HYST} \leq V_{DD} \leq 6.5\text{ V}$ over the operating temperature range of $-40^{\circ}\text{C} \leq T_A, T_A \leq 125^{\circ}\text{C}$ (unless otherwise noted); the open-drain pullup resistors are 10 kΩ for each output; typical values are at $T_A = 25^{\circ}\text{C}$

PARAMETER	TEST CONDITIONS	MIN	TYP	MAX	UNIT	
GENERAL CHARACTERISTICS						
V _{DD} ^{(1) (2) (3)}	Supply voltage	1.6		6.5	V	
I _{DD}	Supply current		10	19	μA	
RESET FUNCTION						
V _{POR} ⁽²⁾	Power-on reset voltage	I _{RESET} = 15 μA, V _{OL(MAX)} = 0.25 V			0.8	V
V _{UVLO} ⁽¹⁾	Undervoltage lockout voltage		1.35		V	
V _{ITN}	Undervoltage threshold accuracy, entering RESET	V _{DD} falling	V _{ITN} - 0.8%	V _{ITN} + 0.8%		
V _{HYST}	Hysteresis voltage	V _{DD} rising	0.2%	0.5%	0.8%	
I _{MR}	MR pin internal pullup current	V _{MR} = 0 V	500	620	700	nA
WATCHDOG FUNCTION						
I _{CWD}	CWD pin charge current	CWD = 0.5 V	347	375	403	nA
V _{CWD}	CWD pin threshold voltage		1.196	1.21	1.224	V
V _{OL}	RESET, W _D O output low	V _{DD} = 5 V, I _{SINK} = 3 mA			0.4	V
I _D	RESET, W _D O output leakage current, open-drain	V _{DD} = V _{ITN} + V _{HYST} , V _{RESET} = V _{WDO} = 6.5 V			1	μA
V _{IL}	Low-level input voltage (MR, SET1)			0.25	V	
V _{IH}	High-level input voltage (MR, SET1)		0.8		V	
V _{IL(WDI)}	Low-level input voltage (WDI)			0.3 × V _{DD}	V	
V _{IH(WDI)}	High-level input voltage (WDI)		0.8 × V _{DD}		V	

(1) When V_{DD} falls below V_{UVLO}, RESET is driven low.

(2) When V_{DD} falls below V_{POR}, RESET and W_DO are undefined.

(3) During power-on, V_{DD} must be a minimum 1.6 V for at least 300 μs before RESET correlates with V_{DD}.

6.6 Timing Requirements

at $V_{ITN} + V_{HYST} \leq V_{DD} \leq 6.5$ V over the operating temperature range of $-40^{\circ}\text{C} \leq T_A, T_A \leq 125^{\circ}\text{C}$ (unless otherwise noted); the open-drain pullup resistors are 10 k Ω for each output; typical values are at $T_A = 25^{\circ}\text{C}$

		MIN	NOM	MAX	UNIT	
GENERAL						
t_{INIT}	CWD pin evaluation period ⁽¹⁾		381		μs	
	Minimum $\overline{\text{MR}}$, SET1 pin pulse duration		1		μs	
	Startup delay ⁽³⁾		300		μs	
RESET FUNCTION						
t_{RST}	Reset timeout period	170	200	230	ms	
$t_{RST-DEL}$	V_{DD} to $\overline{\text{RESET}}$ delay	$V_{DD} = V_{ITN} + V_{HYST} + 2.5\%$	35		μs	
		$V_{DD} = V_{ITN} - 2.5\%$	17			
t_{MR-DEL}	$\overline{\text{MR}}$ to $\overline{\text{RESET}}$ delay		200		ns	
WATCHDOG FUNCTION						
t_{WD}	Watchdog timeout ⁽³⁾	CWD = NC, SET1 = 0 ⁽²⁾	Watchdog disabled			
		CWD = NC, SET1 = 1 ⁽²⁾	1360	1600	1840	ms
		CWD = 10 k Ω to VDD, SET1 = 0 ⁽²⁾	Watchdog disabled			
		CWD = 10 k Ω to VDD, SET1 = 1 ⁽²⁾	170	200	230	ms
$t_{WD-setup}$	Setup time required for device to respond to changes on WDI after being enabled		150		μs	
		Minimum WDI pulse duration		50		ns
t_{WD-del}	WDI to WDO delay		50		ns	

(1) Refer to [Section 8.1.1.2](#)

(2) SET1 = 0 means $V_{SET1} < V_{IL}$; SET1 = 1 means $V_{SET1} > V_{IH}$.

(3) The fixed watchdog timing covers both standard and extended versions.

6.7 Timing Diagrams

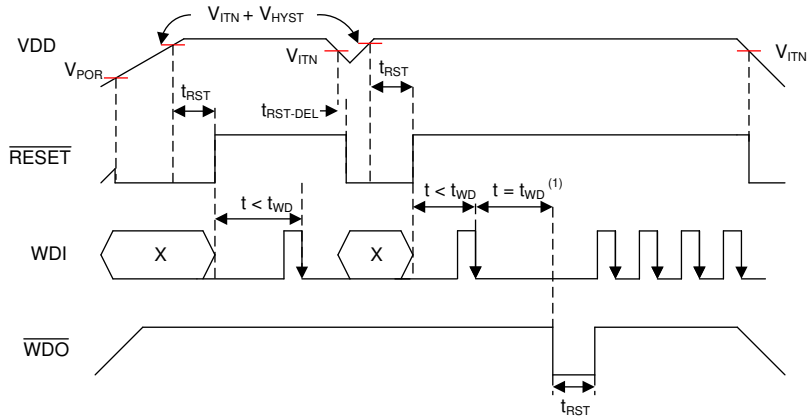

A. See Figure 6-2 for WDI timing requirements.

Figure 6-1. Timing Diagram

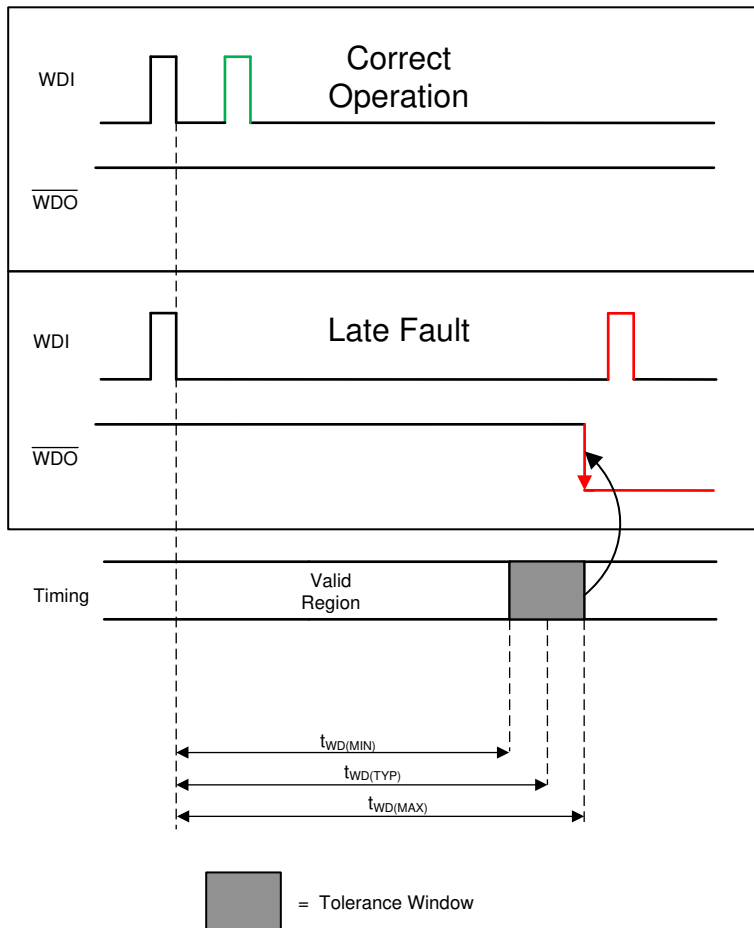
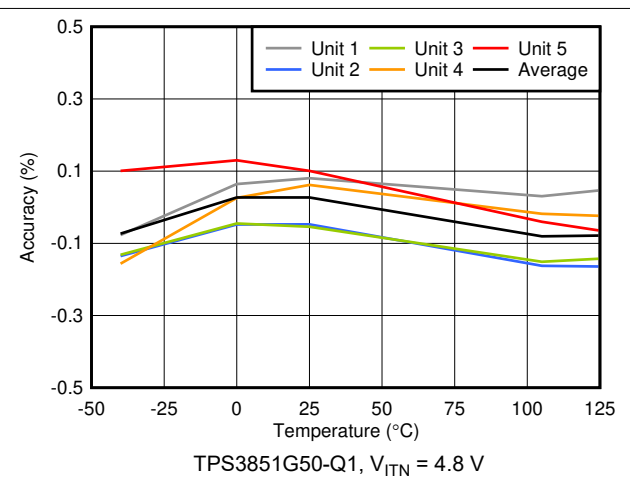
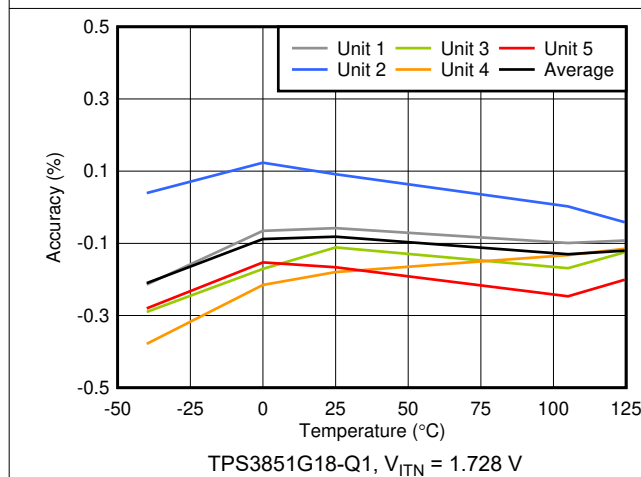
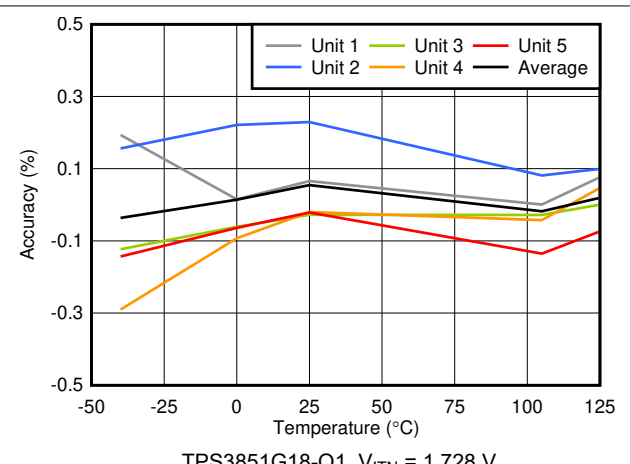
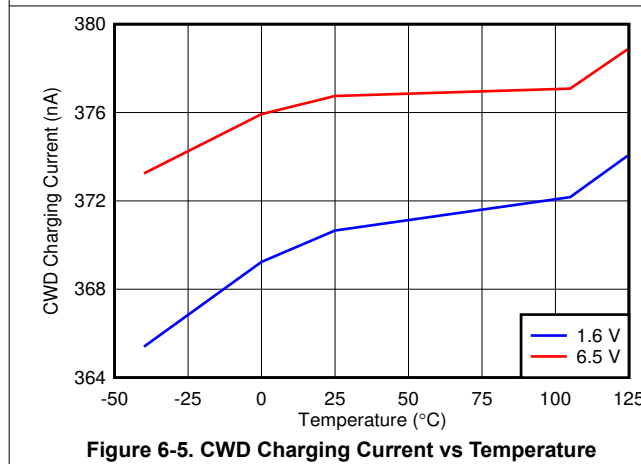
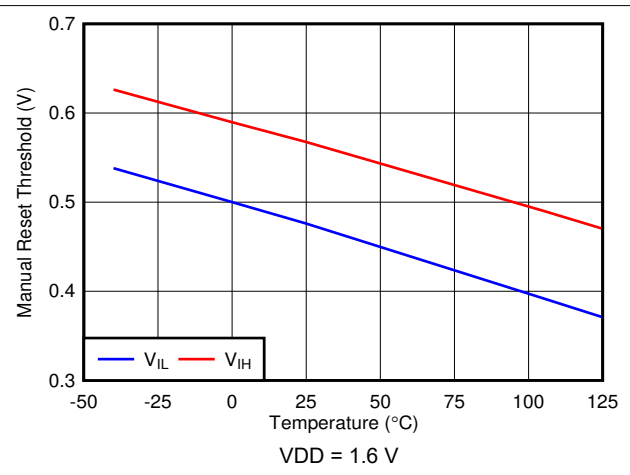
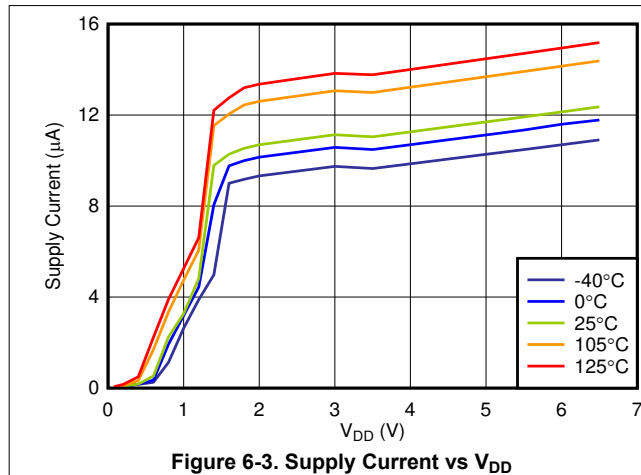

Figure 6-2. Watchdog Timing Diagram

6.8 Typical Characteristics

all typical characteristics curves are taken at 25°C with 1.6 V ≤ VDD ≤ 6.5 V (unless other wise noted)



6.8 Typical Characteristics (continued)

all typical characteristics curves are taken at 25°C with 1.6 V ≤ VDD ≤ 6.5 V (unless other wise noted)

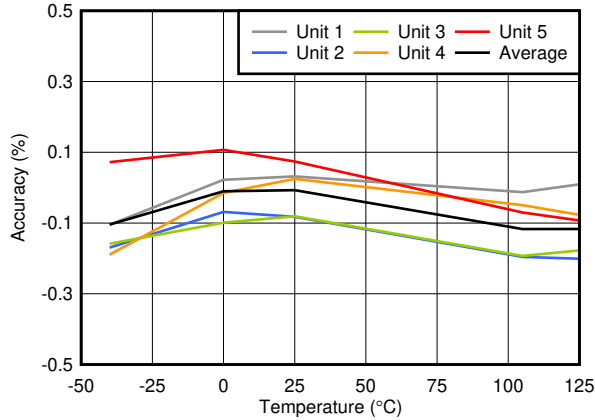

TPS3851G50-Q1, V_{ITN} = 4.8 V
Figure 6-9. V_{ITN} Accuracy vs Temperature

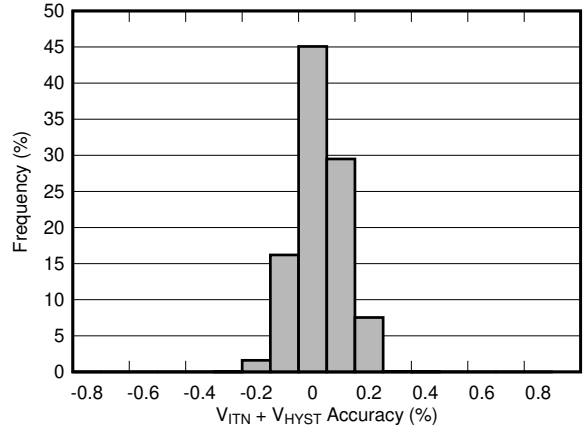

Includes G and H versions; 1.8-V, 2.5-V, 3.0-V, 3.3-V, and 5-V thresholds; total units = 36,627

Figure 6-10. V_{ITN} + V_{HYST} Accuracy Histogram

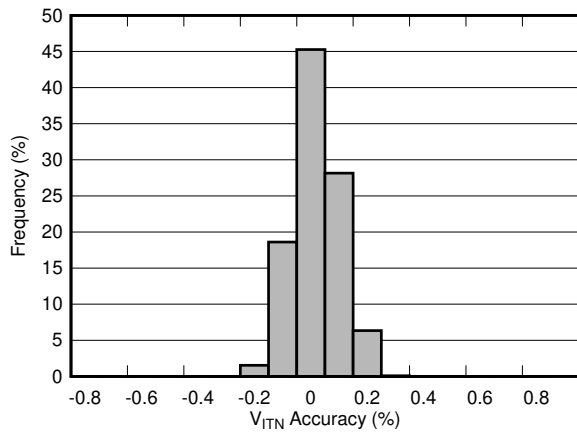

Includes G and H versions; 1.8-V, 2.5-V, 3.0-V, 3.3-V, and 5-V thresholds; total units = 36,627

Figure 6-11. V_{ITN} Accuracy Histogram

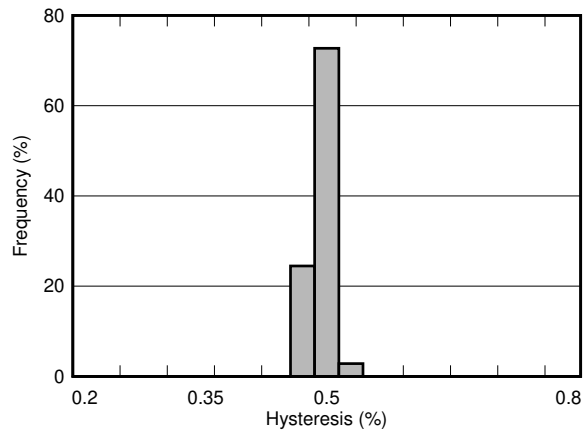

Includes G and H versions; 1.8-V, 2.5-V, 3.0-V, 3.3-V, and 5-V thresholds; total units = 36,627

Figure 6-12. Hysteresis Histogram

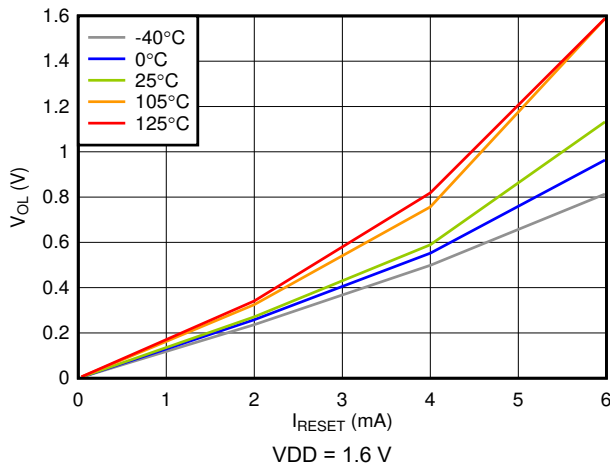

Figure 6-13. Low-Level RESET Voltage vs RESET Current

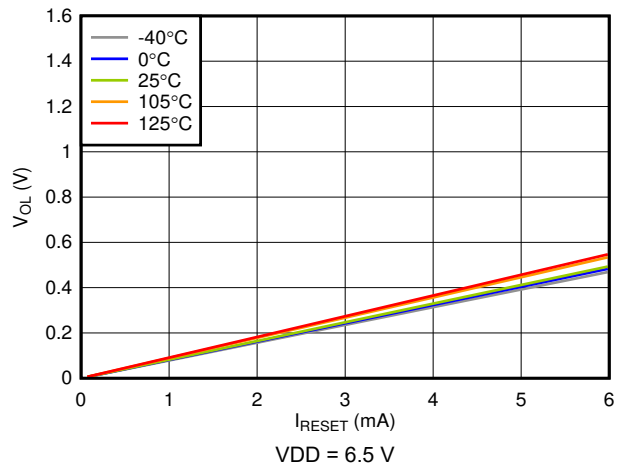
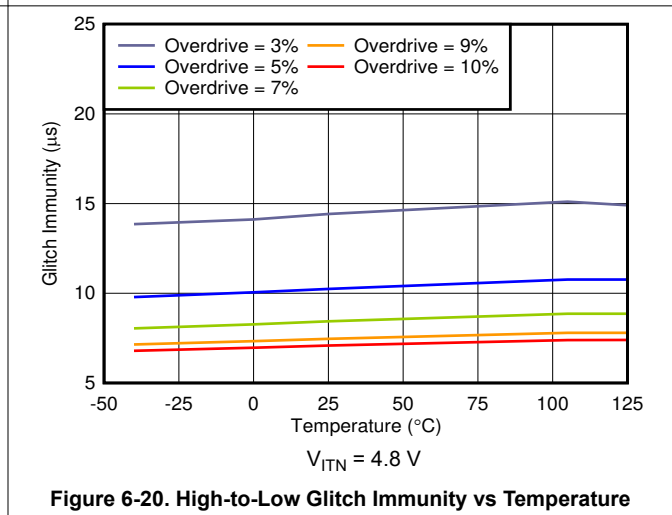
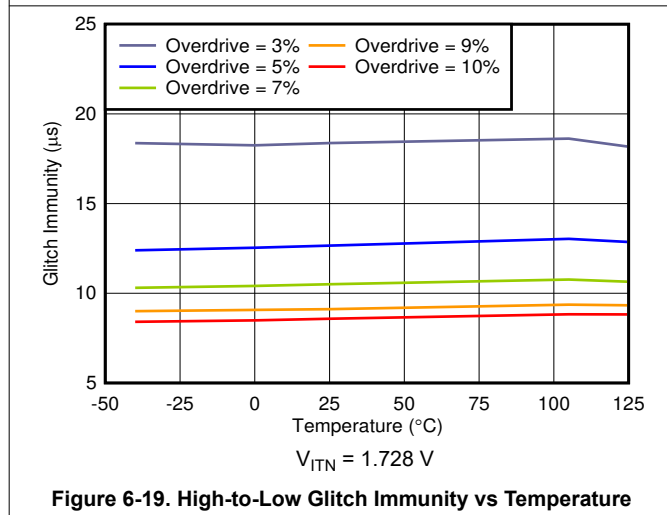
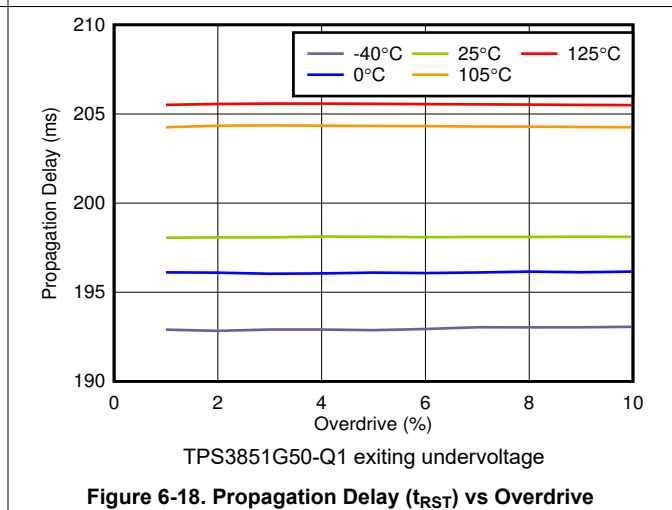
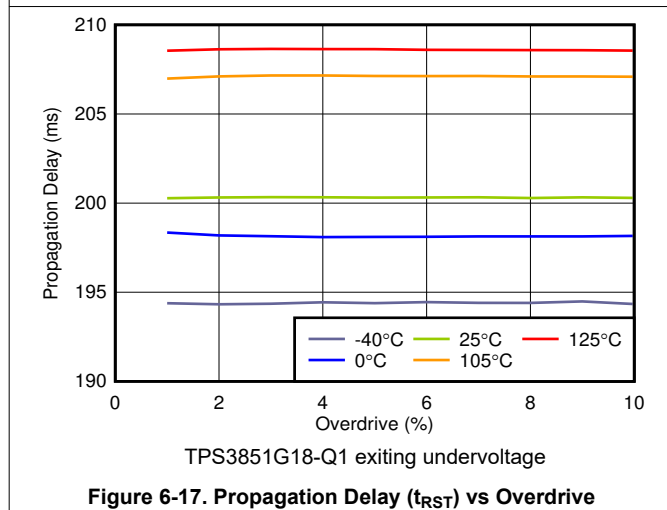
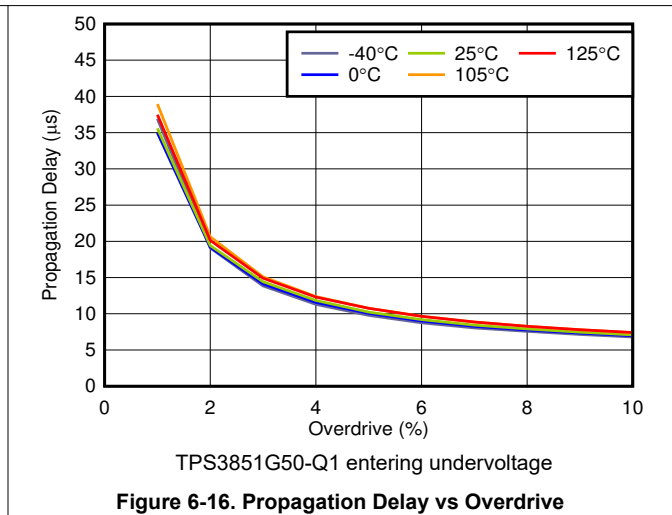
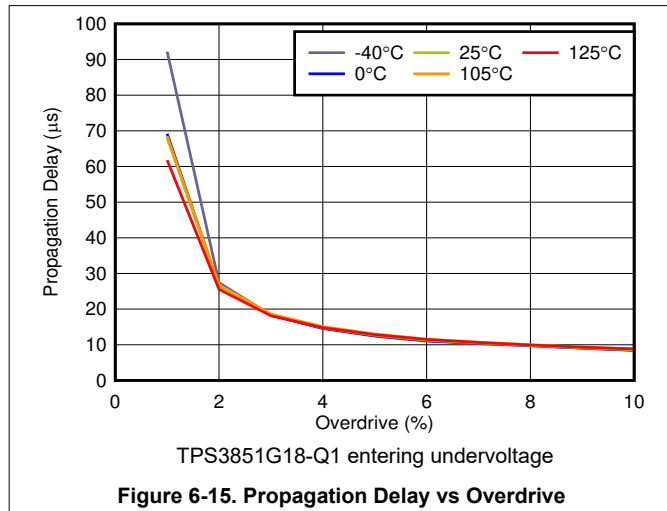

Figure 6-14. Low-Level RESET Voltage vs RESET Current

6.8 Typical Characteristics (continued)

all typical characteristics curves are taken at 25°C with 1.6 V ≤ VDD ≤ 6.5 V (unless other wise noted)



7 Detailed Description

7.1 Overview

The TPS3851-Q1 is a high-accuracy voltage supervisor with an integrated watchdog timer. This device includes a precision undervoltage supervisor with a threshold that achieves 0.8% accuracy over the specified temperature range of -40°C to $+125^{\circ}\text{C}$. In addition, the TPS3851-Q1 includes accurate hysteresis on the threshold, making the device ideal for use with tight tolerance systems where voltage supervisors must ensure a $\overline{\text{RESET}}$ before the minimum supply tolerance of the microprocessor or system-on-a-chip (SoC) is reached. There are two options for the watchdog timing standard and extended timing. To get standard timing use the TPS3851Xyy(y)S-Q1, for extended timing use the TPS3851Xyy(y)E-Q1.

7.2 Functional Block Diagram

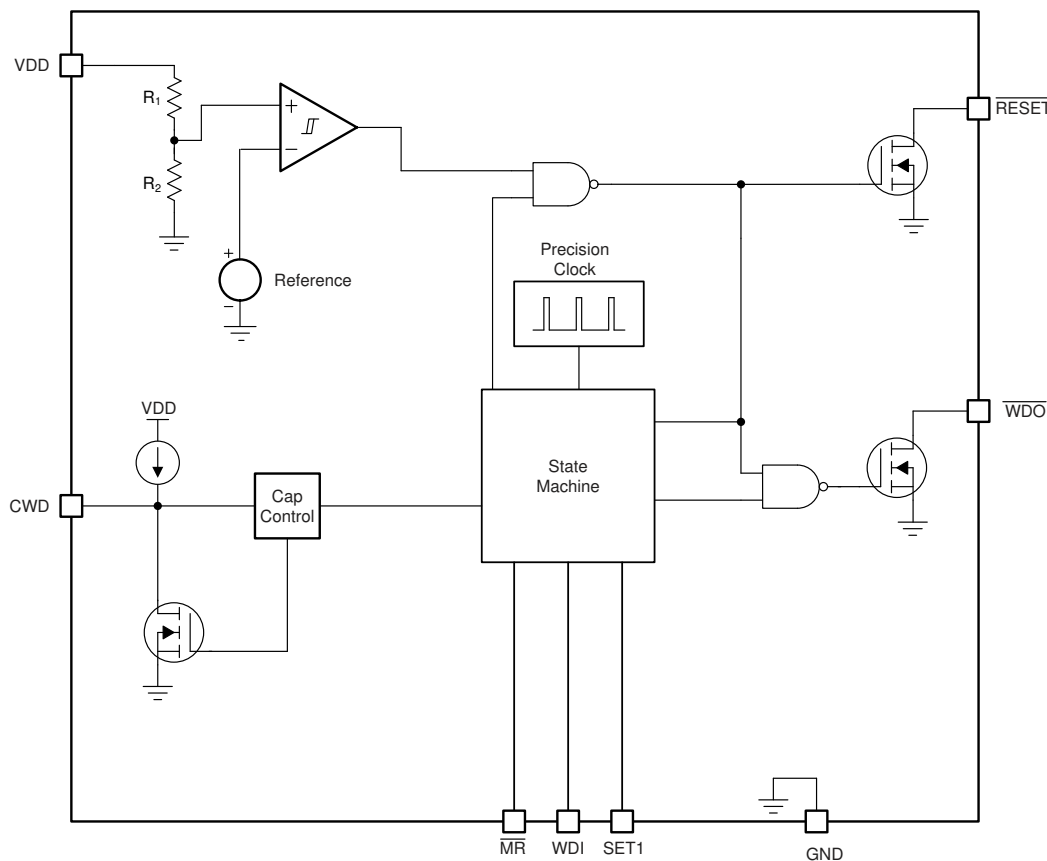

$$R_1 + R_2 = 4.5 \text{ M}\Omega.$$

7.3 Feature Description

7.3.1 $\overline{\text{RESET}}$

Connect $\overline{\text{RESET}}$ to V_{PU} through a 1-k Ω to 100-k Ω pullup resistor. $\overline{\text{RESET}}$ remains high (deasserted) when V_{DD} is greater than the negative threshold voltage (V_{ITN}). If V_{DD} falls below the negative threshold (V_{ITN}), then $\overline{\text{RESET}}$ is asserted, driving the $\overline{\text{RESET}}$ pin to low impedance. When V_{DD} rises above $V_{\text{ITN}} + V_{\text{HYST}}$, a delay circuit is enabled that holds $\overline{\text{RESET}}$ low for a specified reset delay period (t_{RST}). When the reset delay has elapsed, the $\overline{\text{RESET}}$ pin goes to a high-impedance state and uses a pullup resistor to hold $\overline{\text{RESET}}$ high. The pullup resistor must be connected to the proper voltage rail to allow other devices to be connected at the correct interface voltage. To ensure proper voltage levels, give some consideration when choosing the pullup resistor values. The pullup resistor value is determined by output logic low voltage (V_{OL}), capacitive loading, leakage current (I_{D}), and the current through the $\overline{\text{RESET}}$ pin $I_{\overline{\text{RESET}}}$.

7.3.2 Manual Reset $\overline{\text{MR}}$

The manual reset ($\overline{\text{MR}}$) input allows a processor or other logic circuits to initiate a reset. A logic low on $\overline{\text{MR}}$ causes $\overline{\text{RESET}}$ to assert. After $\overline{\text{MR}}$ returns to a logic high and V_{DD} is above $V_{\text{ITN}} + V_{\text{HYST}}$, $\overline{\text{RESET}}$ is deasserted after the reset delay time (t_{RST}). If $\overline{\text{MR}}$ is not controlled externally, then $\overline{\text{MR}}$ can either be connected to V_{DD} or left floating because the $\overline{\text{MR}}$ pin is internally pulled up.

7.3.3 UV Fault Detection

The TPS3851-Q1 features undervoltage detection for common rails between 1.8 V and 5 V. The voltage is monitored on the input rail of the device. If V_{DD} drops below V_{ITN} , then $\overline{\text{RESET}}$ is asserted (driven low).

Figure 7-1 shows that when V_{DD} is above $V_{\text{ITN}} + V_{\text{HYST}}$, $\overline{\text{RESET}}$ deasserts after t_{RST} . The internal comparator has built-in hysteresis that provides some noise immunity and ensures stable operation. Although not required in most cases, for noisy applications, good analog design practice is to place a 1-nF to 100-nF bypass capacitor close to the VDD pin to reduce sensitivity to transient voltages on the monitored signal.

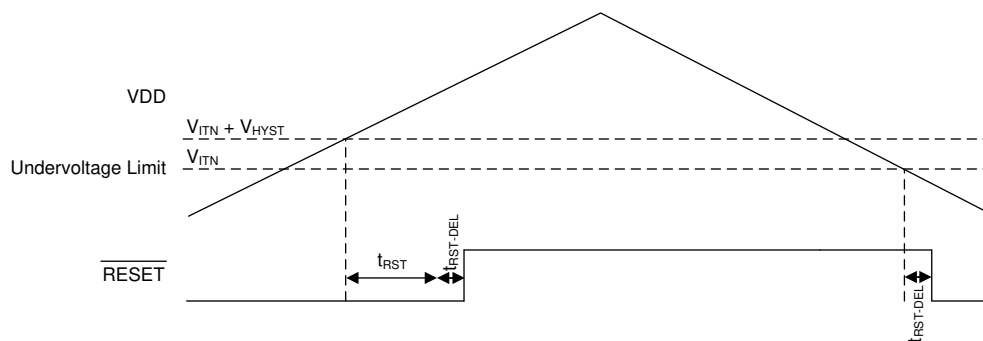

Figure 7-1. Undervoltage Detection

7.3.4 Watchdog Mode

This section provides information for the watchdog mode of operation.

7.3.4.1 CWD

The CWD pin provides the user the functionality of both high-precision, factory-programmed watchdog timing options and user-programmable watchdog timing. The TPS3851-Q1 features three options for setting the watchdog timer: connecting a capacitor to the CWD pin, connecting a pullup resistor to V_{DD} , and leaving the CWD pin unconnected. The configuration of the CWD pin is evaluated by the device every time V_{DD} enters the valid region ($V_{\text{ITN}} + V_{\text{HYST}} < V_{\text{DD}}$). The pin evaluation is controlled by an internal state machine that determines which option is connected to the CWD pin. The sequence of events typically takes 381 μs (t_{INIT}) to determine if the CWD pin is left unconnected, pulled-up through a resistor, or connected to a capacitor. If the CWD pin is being pulled up to V_{DD} , a 10-k Ω resistor is required.

7.3.4.2 Watchdog Input $\overline{\text{WDI}}$

$\overline{\text{WDI}}$ is the watchdog timer input that controls the $\overline{\text{WDO}}$ output. The $\overline{\text{WDI}}$ input is triggered by the falling edge of the input signal. To ensure proper functionality of the watchdog timer, always issue the $\overline{\text{WDI}}$ pulse before $t_{\text{WD(min)}}$. If the pulse is issued in this region, then $\overline{\text{WDO}}$ remains unasserted. Otherwise, the device asserts $\overline{\text{WDO}}$, putting the $\overline{\text{WDO}}$ pin into a low-impedance state.

The watchdog input ($\overline{\text{WDI}}$) is a digital pin. In order to ensure there is no increase in I_{DD} , drive the $\overline{\text{WDI}}$ pin to either V_{DD} or GND at all times. Putting the pin to an intermediate voltage can cause an increase in supply current (I_{DD}) because of the architecture of the digital logic gates. When $\overline{\text{RESET}}$ is asserted, the watchdog is disabled and all signals input to $\overline{\text{WDI}}$ are ignored. When $\overline{\text{RESET}}$ is no longer asserted, the device resumes normal operation and no longer ignores the signal on $\overline{\text{WDI}}$. If the watchdog is disabled, drive the $\overline{\text{WDI}}$ pin to either V_{DD} or GND . Figure 7-2 shows the valid region for a $\overline{\text{WDI}}$ pulse to be issued to prevent $\overline{\text{WDO}}$ from being triggered and pulled low.

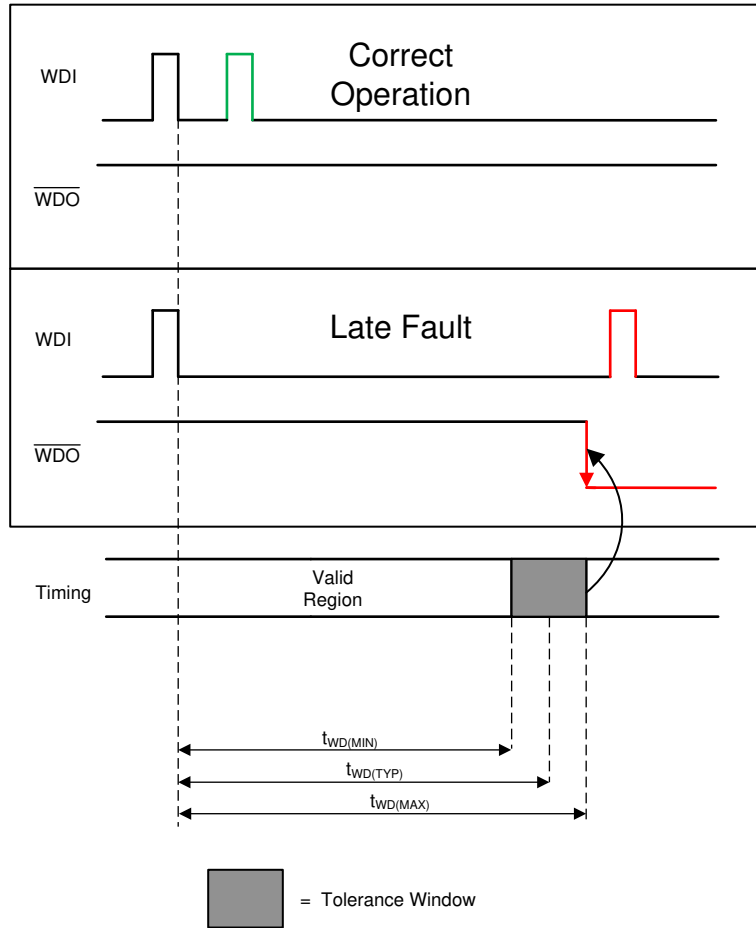

Figure 7-2. Watchdog Timing Diagram

7.3.4.3 Watchdog Output \overline{WDO}

The TPS3851-Q1 features a watchdog timer with an independent watchdog output (\overline{WDO}). The independent watchdog output provides the flexibility to flag a fault in the watchdog timing without performing an entire system reset. When \overline{RESET} is not asserted (high), the \overline{WDO} signal maintains normal operation. When asserted, \overline{WDO} remains low for t_{RST} . When the \overline{RESET} signal is asserted (low), the \overline{WDO} pin goes to a high-impedance state. When \overline{RESET} is unasserted, the watchdog timer resumes normal operation.

7.3.4.4 SET1

The SET1 pin can enable and disable the watchdog timer. If SET1 is set to GND, the watchdog timer is disabled and WDI is ignored. If the watchdog timer is disabled, drive the WDI pin to either GND or VDD to ensure that there is no increase in I_{DD}. When SET1 is logic high, the watchdog operates normally. The SET1 pin can be changed dynamically; however, if the watchdog is going from disabled to enabled (as shown in Figure 7-3) there is a 150-μs setup time where the watchdog does not respond to changes on WDI.

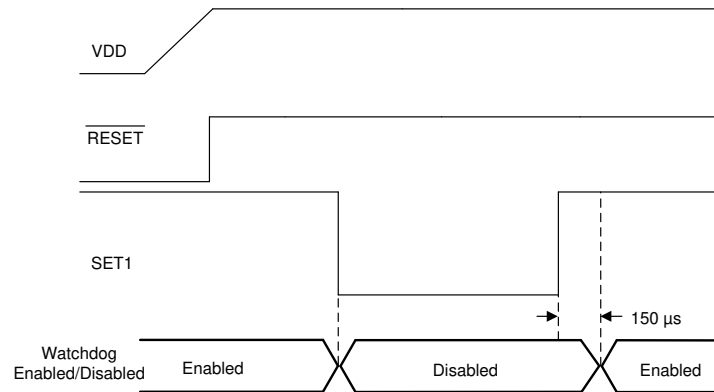

Figure 7-3. Enabling and Disabling the Watchdog

7.4 Device Functional Modes

Table 7-1 summarises the functional modes of the TPS3851-Q1.

Table 7-1. Device Functional Modes

V _{DD}	WDI	WDO	RESET
V _{DD} < V _{POR}	—	—	Undefined
V _{POR} ≤ V _{DD} < V _{DD(min)}	Ignored	High	Low
V _{DD(min)} ≤ V _{DD} ≤ V _{ITN} + V _{HYST} ⁽¹⁾	Ignored	High	Low
V _{DD} > V _{ITN} ⁽²⁾	t _{PULSE} < t _{WD(min)} ⁽³⁾	High	High
V _{DD} > V _{ITN} ⁽²⁾	t _{PULSE} > t _{WD(min)} ⁽³⁾	Low	High

(1) Only valid before V_{DD} has gone above V_{ITN} + V_{HYST}.

(2) Only valid after V_{DD} has gone above V_{ITN} + V_{HYST}.

(3) Where t_{pulse} is the time between the falling edges on WDI.

7.4.1 V_{DD} is Below V_{POR} (V_{DD} < V_{POR})

When V_{DD} is less than V_{POR}, $\overline{\text{RESET}}$ is undefined and can be either high or low. The state of $\overline{\text{RESET}}$ largely depends on the load that the $\overline{\text{RESET}}$ pin is experiencing.

7.4.2 Above Power-On-Reset, But Less Than V_{DD(min)} (V_{POR} ≤ V_{DD} < V_{DD(min)})

When the voltage on V_{DD} is less than V_{DD(min)}, and greater than or equal to V_{POR}, the $\overline{\text{RESET}}$ signal is asserted (logic low). When $\overline{\text{RESET}}$ is asserted, the watchdog output $\overline{\text{WDO}}$ is in a high-impedance state regardless of the WDI signal that is input to the device.

7.4.3 Normal Operation (V_{DD} ≥ V_{DD(min)})

When V_{DD} is greater than or equal to V_{DD(min)}, the $\overline{\text{RESET}}$ signal is determined by V_{DD}. When $\overline{\text{RESET}}$ is asserted, $\overline{\text{WDO}}$ goes to a high-impedance state. $\overline{\text{WDO}}$ is then pulled high through the pullup resistor.

8 Application and Implementation

Note

Information in the following applications sections is not part of the TI component specification, and TI does not warrant its accuracy or completeness. TI's customers are responsible for determining suitability of components for their purposes, as well as validating and testing their design implementation to confirm system functionality.

8.1 Application Information

The following sections describe in detail proper device implementation, depending on the final application requirements.

8.1.1 CWD Functionality

The TPS3851-Q1 features three options for setting the watchdog timer: connecting a capacitor to the CWD pin, connecting a pullup resistor to VDD, and leaving the CWD pin unconnected. Figure 8-1 shows a schematic drawing of all three options. If this pin is connected to VDD through a 10-kΩ pullup resistor or left unconnected (high impedance), then the factory-programmed watchdog timeouts are enabled; see the Section 8.1.1.1 section. Otherwise, the watchdog timeout can be adjusted by placing a capacitor from the CWD pin to ground.

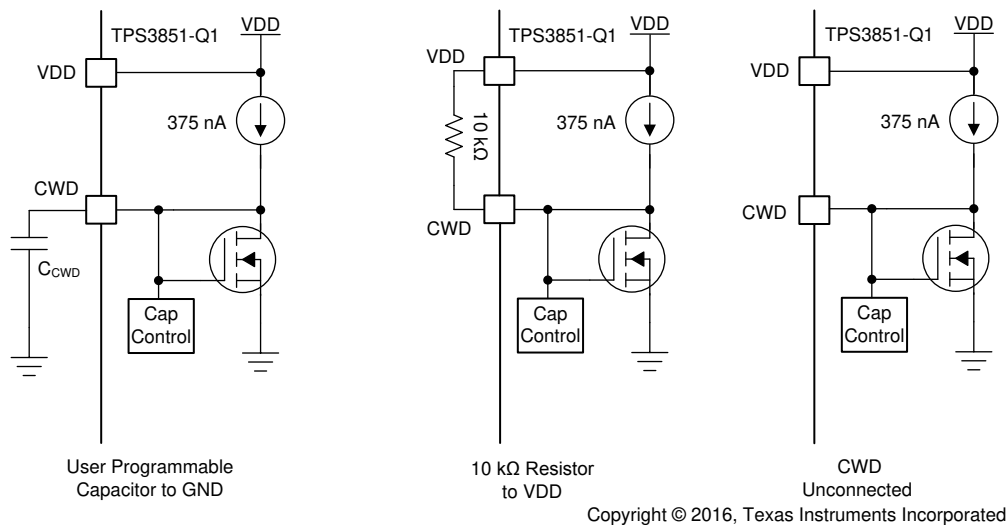

Figure 8-1. CWD Charging Circuit

8.1.1.1 Factory-Programmed Timing Options

If using the factory-programmed timing options (listed in Table 8-1), the CWD pin must either be unconnected or pulled up to VDD through a 10-kΩ pullup resistor. Using these options enables high-precision, 15% accurate watchdog timing.

Table 8-1. Factory Programmed Watchdog Timing

INPUT		STANDARD AND EXTENDED TIMING WDT (t_{wd})			UNIT
CWD	SET1	MIN	TYP	MAX	
NC	0	Watchdog disabled			
NC	1	1360	1600	1840	ms
10 kΩ to VDD	0	Watchdog disabled			
10 kΩ to VDD	1	170	200	230	ms

8.1.1.2 Adjustable Capacitor Timing

Adjustable capacitor timing is achievable by connecting a capacitor to the CWD pin. If a capacitor is connected to CWD, then a 375-nA, constant-current source charges C_{CWD} until $V_{CWD} = 1.21$ V. [Table 8-2](#) shows how to calculate t_{WD} using [Equation 1](#), [Equation 2](#), and the SET1 pin. The TPS3851-Q1 determines the watchdog timeout with the formulas given in [Equation 1](#) and [Equation 2](#), where C_{CWD} is in nanofarads and t_{WD} is in milliseconds.

$$t_{WD(\text{standard})} (\text{ms}) = 3.23 \times C_{CWD} (\text{nF}) + 0.381 (\text{ms}) \quad (1)$$

$$t_{WD(\text{extended})} (\text{ms}) = 77.4 \times C_{CWD} (\text{nF}) + 55 (\text{ms}) \quad (2)$$

The TPS3851-Q1 is designed and tested using C_{CWD} capacitors between 100 pF and 1 μF . [Equation 1](#) and [Equation 2](#) are for ideal capacitors; capacitor tolerances vary the actual device timing. For the most accurate timing, use ceramic capacitors with COG dielectric material. If a C_{CWD} capacitor is used, [Equation 1](#) can be used to set t_{WD} for standard timing. Use [Equation 2](#) to calculate t_{WD} for extended timing. [Table 8-3](#) shows the minimum and maximum calculated t_{WD} values using an ideal capacitor for both standard and extended timing.

Table 8-2. Programmable CWD Timing

INPUT		STANDARD TIMING WDT (t_{WD})			EXTENDED TIMING WDT (t_{WD})			UNIT
CWD	SET1	MIN	TYP	MAX	MIN	TYP	MAX	
C_{CWD}	0	Watchdog disabled			Watchdog disabled			
C_{CWD}	1	$t_{WD(\text{std})} \times 0.905$	$t_{WD(\text{std})}^{(1)}$	$t_{WD(\text{std})} \times 1.095$	$t_{WD(\text{ext})} \times 0.905$	$t_{WD(\text{ext})}^{(2)}$	$t_{WD(\text{ext})} \times 1.095$	ms

(1) Calculated from [Equation 1](#) using an ideal capacitor.

(2) Calculated from [Equation 2](#) using an ideal capacitor.

Table 8-3. t_{WD} Values for Common Ideal Capacitor Values

C_{CWD}	STANDARD TIMING WDT (t_{WD})			EXTENDED TIMING WDT (t_{WD})			UNIT
	MIN ⁽¹⁾	TYP	MAX ⁽¹⁾	MIN ⁽¹⁾	TYP	MAX ⁽¹⁾	
100 pF	0.637	0.704	0.771	56.77	62.74	68.7	ms
1 nF	3.268	3.611	3.954	119.82	132.4	144.98	ms
10 nF	29.58	32.68	35.79	750	829	908	ms
100 nF	292.7	323.4	354.1	7054	7795	8536	ms
1 μF	2923	3230	3537	70096	77455	84814	ms

(1) The minimum and maximum values are calculated using an ideal capacitor.

8.1.2 Overdrive Voltage

Forcing a $\overline{\text{RESET}}$ is dependent on two conditions: the amplitude V_{DD} is beyond the trip point (ΔV_1 and ΔV_2), and the length of time that the voltage is beyond the trip point (t_1 and t_2). If the voltage is just under the trip point for a long period of time, $\overline{\text{RESET}}$ asserts and the output is pulled low. However, if V_{DD} is just under the trip point for a few nanoseconds, $\overline{\text{RESET}}$ does not assert and the output remains high. The length of time required for $\overline{\text{RESET}}$ to assert can be changed by increasing the amount V_{DD} goes under the trip point. If V_{DD} is under the trip point by 10%, the amount of time required for the comparator to respond is much faster and causes $\overline{\text{RESET}}$ to assert much quicker than when barely under the trip point voltage. Equation 3 shows how to calculate the percentage overdrive.

$$\text{Overdrive} = |(V_{DD} / V_{ITX}) - 1| \times 100\% \quad (3)$$

In Equation 3, V_{ITX} corresponds to the threshold trip point. If V_{DD} is exceeding the positive threshold, $V_{ITN} + V_{HYST}$ is used. V_{ITN} is used when V_{DD} is falling below the negative threshold. In Figure 8-2, t_1 and t_2 correspond to the amount of time that V_{DD} is over the threshold; the propagation delay versus overdrive for V_{ITN} and $V_{ITN} + V_{HYST}$ is illustrated in Figure 6-16 and Figure 6-18, respectively.

The TPS3851-Q1 is relatively immune to short positive and negative transients on V_{DD} because of the overdrive voltage curve.

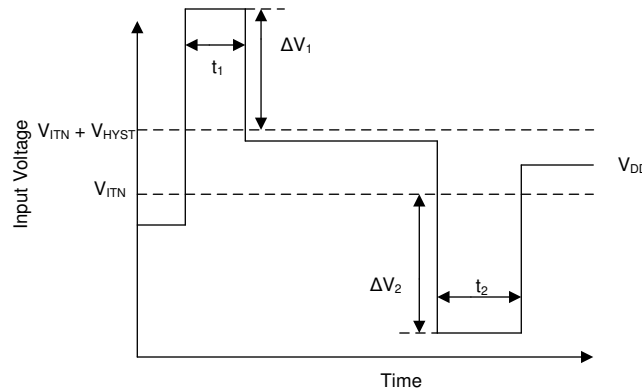
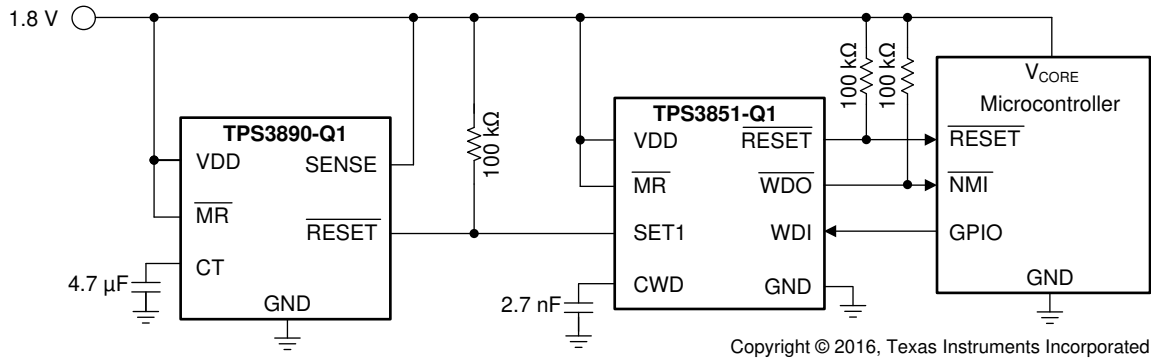

Figure 8-2. Overdrive Voltage

8.2 Typical Application



Copyright © 2016, Texas Instruments Incorporated

Figure 8-3. Monitoring the Supply Voltage and Watchdog Supervision of a Microcontroller

8.2.1 Design Requirements

PARAMETER	DESIGN REQUIREMENT	DESIGN RESULT
Watchdog disable for initialization period	Watchdog must remain disabled for 5 seconds until logic enables the watchdog timer	5.02 seconds (typ)
Output logic voltage	1.8-V CMOS	1.8-V CMOS
Monitored rail	1.8 V with a 5% threshold	Worst-case $V_{ITN} = 1.714\text{ V} - 4.7\%$
Watchdog timeout	10 ms, typical	$t_{WD(min)} = 7.3\text{ ms}$, $t_{WD(TYP)} = 9.1\text{ ms}$, $t_{WD(max)} = 11\text{ ms}$
Maximum device current consumption	50 μA	37 μA when $\overline{\text{RESET}}$ or $\overline{\text{WDO}}$ is asserted ⁽¹⁾

(1) Only includes the TPS3851G18S-Q1 current consumption.

8.2.2 Detailed Design Procedure

8.2.2.1 Monitoring the 1.8-V Rail

The undervoltage comparator allows for precise voltage supervision of common rails between 1.8 V and 5.0 V. This application calls for very tight monitoring of the rail with only 5% of variation allowed on the rail. To ensure this requirement is met, the TPS3851G18S-Q1 was chosen for its –4% threshold. To calculate the worst-case for V_{ITN} , the accuracy must also be taken into account. The worst-case for V_{ITN} can be calculated by Equation 4:

$$V_{ITN(\text{Worst Case})} = V_{ITN(\text{typ})} \times 0.992 = 1.8 \times 0.96 \times 0.992 = 1.714\text{ V} \quad (4)$$

8.2.2.2 Calculating the $\overline{\text{RESET}}$ and $\overline{\text{WDO}}$ Pullup Resistor

Figure 8-4 shows the TPS3851-Q1 using an open-drain configuration for the $\overline{\text{RESET}}$ circuit. When the FET is off, the resistor pulls the drain of the transistor to VDD and when the FET is turned on, the FET attempts to pull the drain to ground, thus creating an effective resistor divider. The resistors in this divider must be chosen to ensure that V_{OL} is below the maximum value. To choose the proper pullup resistor, there are three key specifications to keep in mind: the pullup voltage (V_{PU}), the recommended maximum $\overline{\text{RESET}}$ pin current ($I_{\overline{\text{RESET}}}$), and V_{OL} . The maximum V_{OL} is 0.4 V, meaning that the effective resistor divider created must be able to bring the voltage on the reset pin below 0.4 V with $I_{\overline{\text{RESET}}}$ kept below 10 mA. For this example, with a V_{PU} of 1.8 V, a resistor must be chosen to keep $I_{\overline{\text{RESET}}}$ below 50 μA because this value is the maximum consumption current allowed. To ensure this specification is met, a pullup resistor value of 100 k Ω was selected, which sinks a maximum of 18 μA when $\overline{\text{RESET}}$ or $\overline{\text{WDO}}$ is asserted. As illustrated in Figure 6-13, the $\overline{\text{RESET}}$ current is at 18 μA and the low-level output voltage is approximately zero.

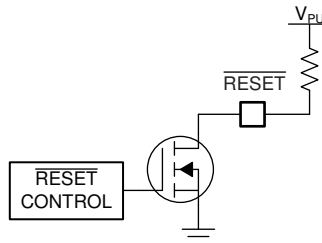

Figure 8-4. $\overline{\text{RESET}}$ Open-Drain Configuration

8.2.2.3 Setting the Watchdog

As illustrated in Figure 8-1 there are three options for setting the watchdog timer. The design specifications in this application require the programmable timing option (external capacitor connected to CWD). When a capacitor is connected to the CWD pin, the watchdog timer is governed by Equation 1 for the standard timing version. However, only the standard version is capable of meeting this timing requirement. Equation 1 is only valid for ideal capacitors, any temperature or voltage derating must be accounted for separately.

$$C_{\text{CWD}} \text{ (nF)} = (t_{\text{WD}}(\text{ms}) - 0.0381) / 3.23 = (10 - 0.381) / 3.23 = 2.97 \text{ nF} \quad (5)$$

The nearest standard capacitor value to 2.9 nF is 2.7 nF. Selecting 2.7 nF for the C_{CWD} capacitor gives the following minimum timing parameters:

$$t_{\text{WD}(\text{MIN})} = 0.905 \times t_{\text{WD}(\text{TYP})} = 0.905 \times (3.23 \times 2.7 + 0.381) = 8.24 \text{ ms} \quad (6)$$

$$t_{\text{WD}(\text{MAX})} = 1.095 \times t_{\text{WD}(\text{TYP})} = 1.095 \times (3.23 \times 2.7 + 0.381) = 9.97 \text{ ms} \quad (7)$$

Capacitor tolerance also influences $t_{\text{WD}(\text{MIN})}$ and $t_{\text{WD}(\text{MAX})}$. Select a ceramic COG dielectric capacitor for high accuracy. For 2.7 nF, COG capacitors are readily available with 5% tolerances. This selection results in a 5% decrease in $t_{\text{WD}(\text{MIN})}$ and a 5% increase in $t_{\text{WD}(\text{MAX})}$, giving 7.34 ms and 11 ms, respectively. To ensure proper functionality, a falling edge must be issued before $t_{\text{WD}(\text{min})}$. Figure 8-6 illustrates that a WDI signal with a period of 5 ms keeps $\overline{\text{WDO}}$ from asserting.

8.2.2.4 Watchdog Disabled During Initialization Period

The watchdog is often needed to be disabled during startup to allow for an initialization period. When the initialization period is over, the watchdog timer is turned back on to allow the microcontroller to be monitored by the TPS3851-Q1. To achieve this setup, SET1 must start at GND. In this design, SET1 is controlled by a TPS3890-Q1 supervisor. In this application, the TPS3890-Q1 was chosen to monitor V_{DD} as well, which means that the $\overline{\text{RESET}}$ on the TPS3890-Q1 stays low until V_{DD} rises above V_{ITN}. When V_{DD} comes up, the delay time can be adjusted through the CT capacitor on the TPS3890-Q1. With this approach, the $\overline{\text{RESET}}$ delay can be adjusted from a minimum of 25 μs to a maximum of 30 seconds. For this design, a typical delay of 5 seconds is needed before the watchdog timer is enabled. The CT capacitor calculation (see the TPS3890-Q1 data sheet) yields an ideal capacitance of 4.67 μF , giving a closest standard ceramic capacitor value of 4.7 μF . When connecting a 4.7- μF capacitor from CT to GND, the typical delay time is 5 seconds. Figure 8-5 shows that when the watchdog is disabled, the $\overline{\text{WDO}}$ output remains high. However when SET1 goes high and there is no WDI signal, $\overline{\text{WDO}}$ begins to assert. See the TPS3890-Q1 data sheet for detailed information on the TPS3890-Q1.

8.2.3 Glitch Immunity

Figure 8-8 shows the high-to-low glitch immunity for the TPS3851G18S-Q1 with a 7% overdrive with V_{DD} starting at 1.8 V. This curve shows that V_{DD} can go below the threshold for at least 6 μs before $\overline{\text{RESET}}$ asserts.

8.2.4 Application Curves

Unless otherwise stated, application curves were taken at T_A = 25°C.

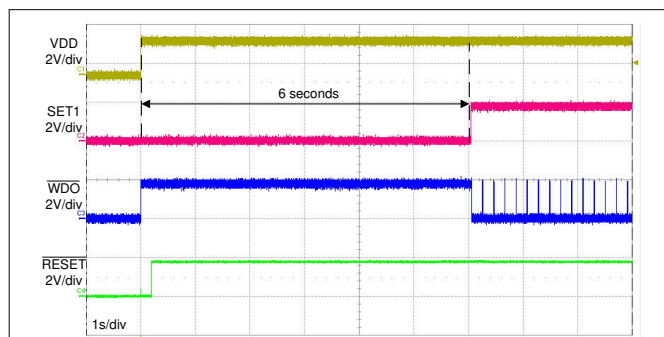

Figure 8-5. Startup Without a WDI Signal

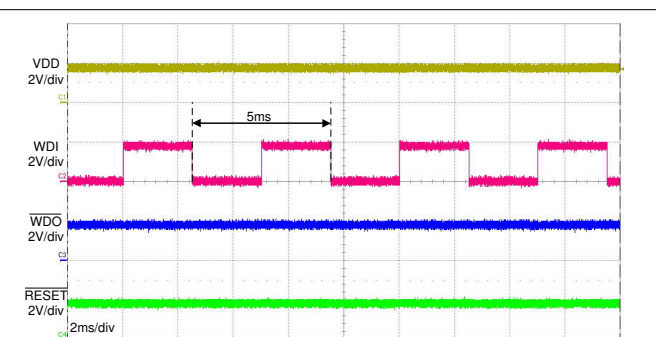

Figure 8-6. Typical WDI Signal

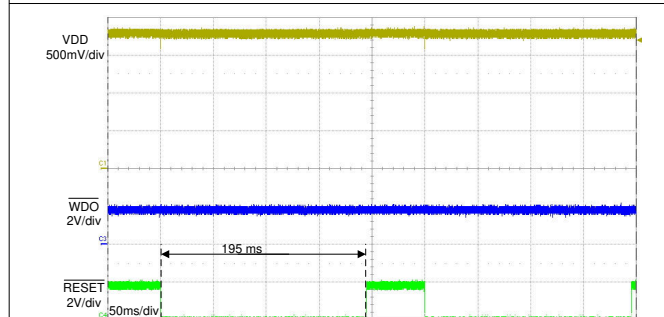

Figure 8-7. Typical RESET Delay

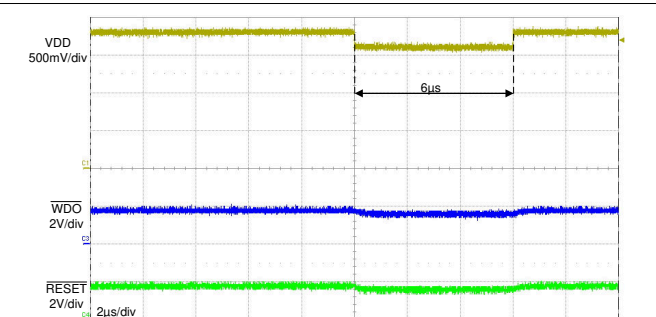

Figure 8-8. High-to-Low Glitch Immunity

9 Power Supply Recommendations

This device is designed to operate from an input supply with a voltage range between 1.6 V and 6.5 V. An input supply capacitor is not required for this device; however, if the input supply is noisy, then good analog practice is to place a 0.1- μ F capacitor between the VDD pin and the GND pin.

10 Layout

10.1 Layout Guidelines

- Make sure that the connection to the VDD pin is low impedance. Good analog design practice is to place a 0.1- μ F ceramic capacitor as near as possible to the VDD pin.
- If a C_{CWD} capacitor or pullup resistor is used, place these components as close as possible to the CWD pin. If the CWD pin is left unconnected, make sure to minimize the amount of parasitic capacitance on the pin.
- Place the pullup resistors on RESET and WDO as close to the pin as possible.

10.2 Layout Example

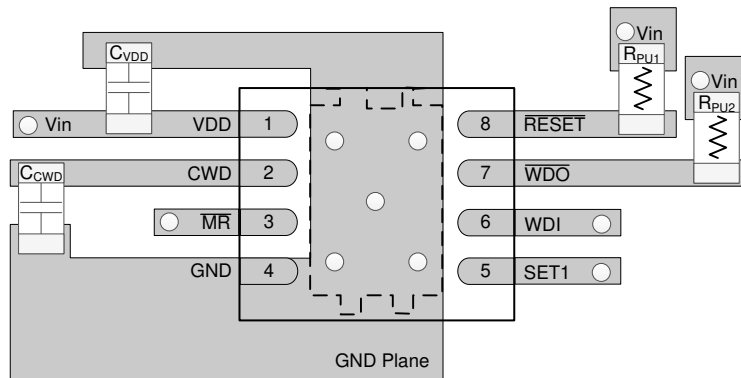

○ Denotes a via

Figure 10-1. TPS3851-Q1 Recommended Layout

11 Device and Documentation Support

11.1 Device Support

11.1.1 Device Nomenclature

Table 11-1. Device Nomenclature

DESCRIPTION	NOMENCLATURE	VALUE
TPS3851-Q1 (high-accuracy supervisor with watchdog)	—	—
X (nominal threshold as a percent of the nominal monitored voltage)	G	$V_{ITN} = -4\%$
	H	$V_{ITN} = -7\%$
yy(y) (nominal monitored voltage option)	18	1.8 V
	25	2.5 V
	30	3.0 V
	33	3.3 V
	50	5.0 V
z (nominal watchdog timeout period)	S	$t_{WD} \text{ (ms)} = 3.23 \times C_{WD} \text{ (nF)} + 0.381 \text{ (ms)}$
	E	$t_{WD} \text{ (ms)} = 77.4 \times C_{WD} \text{ (nF)} + 55.2 \text{ (ms)}$

11.2 Documentation Support

11.2.1 Related Documentation

For related documentation see the following:

- [TPS3890-Q1 Low Quiescent Current, 1% Accurate Supervisor with Programmable Delay](#)
- [TPS3851EVM-780 Evaluation Module](#)

11.3 Receiving Notification of Documentation Updates

To receive notification of documentation updates, navigate to the device product folder on ti.com. Click on *Subscribe to updates* to register and receive a weekly digest of any product information that has changed. For change details, review the revision history included in any revised document.

11.4 Support Resources

[TI E2E™ support forums](#) are an engineer's go-to source for fast, verified answers and design help — straight from the experts. Search existing answers or ask your own question to get the quick design help you need.

Linked content is provided "AS IS" by the respective contributors. They do not constitute TI specifications and do not necessarily reflect TI's views; see TI's [Terms of Use](#).

11.5 Trademarks

TI E2E™ is a trademark of Texas Instruments.
All trademarks are the property of their respective owners.

11.6 Electrostatic Discharge Caution



This integrated circuit can be damaged by ESD. Texas Instruments recommends that all integrated circuits be handled with appropriate precautions. Failure to observe proper handling and installation procedures can cause damage.

ESD damage can range from subtle performance degradation to complete device failure. Precision integrated circuits may be more susceptible to damage because very small parametric changes could cause the device not to meet its published specifications.

11.7 Glossary

[TI Glossary](#) This glossary lists and explains terms, acronyms, and definitions.

12 Mechanical, Packaging, and Orderable Information

The following pages include mechanical, packaging, and orderable information. This information is the most current data available for the designated devices. This data is subject to change without notice and revision of this document. For browser-based versions of this data sheet, refer to the left-hand navigation.

PACKAGING INFORMATION

Orderable Device	Status (1)	Package Type	Package Drawing	Pins	Package Qty	Eco Plan (2)	Lead finish/ Ball material (6)	MSL Peak Temp (3)	Op Temp (°C)	Device Marking (4/5)	Samples
TPS3851G18EQDRBRQ1	ACTIVE	SON	DRB	8	3000	RoHS & Green	NIPDAU SN	Level-2-260C-1 YEAR	-40 to 125	851DF	Samples
TPS3851G18SQDRBRQ1	ACTIVE	SON	DRB	8	3000	RoHS & Green	NIPDAU SN	Level-2-260C-1 YEAR	-40 to 125	851DE	Samples
TPS3851G25EQDRBRQ1	ACTIVE	SON	DRB	8	3000	RoHS & Green	NIPDAU SN	Level-2-260C-1 YEAR	-40 to 125	851EF	Samples
TPS3851G25SQDRBRQ1	ACTIVE	SON	DRB	8	3000	RoHS & Green	NIPDAU SN	Level-2-260C-1 YEAR	-40 to 125	851EE	Samples
TPS3851G30EQDRBRQ1	ACTIVE	SON	DRB	8	3000	RoHS & Green	NIPDAU SN	Level-2-260C-1 YEAR	-40 to 125	851FF	Samples
TPS3851G30SQDRBRQ1	ACTIVE	SON	DRB	8	3000	RoHS & Green	NIPDAU SN	Level-2-260C-1 YEAR	-40 to 125	851FE	Samples
TPS3851G33EQDRBRQ1	ACTIVE	SON	DRB	8	3000	RoHS & Green	NIPDAU SN	Level-2-260C-1 YEAR	-40 to 125	851GF	Samples
TPS3851G33SQDRBRQ1	ACTIVE	SON	DRB	8	3000	RoHS & Green	NIPDAU SN	Level-2-260C-1 YEAR	-40 to 125	851GE	Samples
TPS3851G50EQDRBRQ1	ACTIVE	SON	DRB	8	3000	RoHS & Green	NIPDAU SN	Level-2-260C-1 YEAR	-40 to 125	851HF	Samples
TPS3851G50SQDRBRQ1	ACTIVE	SON	DRB	8	3000	RoHS & Green	NIPDAU SN	Level-2-260C-1 YEAR	-40 to 125	851HE	Samples
TPS3851H18EQDRBRQ1	ACTIVE	SON	DRB	8	3000	RoHS & Green	NIPDAU SN	Level-2-260C-1 YEAR	-40 to 125	851LF	Samples
TPS3851H18SQDRBRQ1	ACTIVE	SON	DRB	8	3000	RoHS & Green	NIPDAU SN	Level-2-260C-1 YEAR	-40 to 125	851LE	Samples
TPS3851H25EQDRBRQ1	ACTIVE	SON	DRB	8	3000	RoHS & Green	NIPDAU SN	Level-2-260C-1 YEAR	-40 to 125	851MF	Samples
TPS3851H25SQDRBRQ1	ACTIVE	SON	DRB	8	3000	RoHS & Green	NIPDAU SN	Level-2-260C-1 YEAR	-40 to 125	851ME	Samples
TPS3851H30EQDRBRQ1	ACTIVE	SON	DRB	8	3000	RoHS & Green	NIPDAU SN	Level-2-260C-1 YEAR	-40 to 125	851NF	Samples
TPS3851H30SQDRBRQ1	ACTIVE	SON	DRB	8	3000	RoHS & Green	NIPDAU SN	Level-2-260C-1 YEAR	-40 to 125	851NE	Samples
TPS3851H33EQDRBRQ1	ACTIVE	SON	DRB	8	3000	RoHS & Green	NIPDAU SN	Level-2-260C-1 YEAR	-40 to 125	851PF	Samples
TPS3851H33SQDRBRQ1	ACTIVE	SON	DRB	8	3000	RoHS & Green	NIPDAU SN	Level-2-260C-1 YEAR	-40 to 125	851PE	Samples
TPS3851H50EQDRBRQ1	ACTIVE	SON	DRB	8	3000	RoHS & Green	NIPDAU SN	Level-2-260C-1 YEAR	-40 to 125	851RF	Samples
TPS3851H50SQDRBRQ1	ACTIVE	SON	DRB	8	3000	RoHS & Green	NIPDAU SN	Level-2-260C-1 YEAR	-40 to 125	851RE	Samples

(1) The marketing status values are defined as follows:

ACTIVE: Product device recommended for new designs.

LIFEBUY: TI has announced that the device will be discontinued, and a lifetime-buy period is in effect.

NRND: Not recommended for new designs. Device is in production to support existing customers, but TI does not recommend using this part in a new design.

PREVIEW: Device has been announced but is not in production. Samples may or may not be available.

OBSOLETE: TI has discontinued the production of the device.

(2) **RoHS:** TI defines "RoHS" to mean semiconductor products that are compliant with the current EU RoHS requirements for all 10 RoHS substances, including the requirement that RoHS substance do not exceed 0.1% by weight in homogeneous materials. Where designed to be soldered at high temperatures, "RoHS" products are suitable for use in specified lead-free processes. TI may reference these types of products as "Pb-Free".

RoHS Exempt: TI defines "RoHS Exempt" to mean products that contain lead but are compliant with EU RoHS pursuant to a specific EU RoHS exemption.

Green: TI defines "Green" to mean the content of Chlorine (Cl) and Bromine (Br) based flame retardants meet JS709B low halogen requirements of ≤ 1000 ppm threshold. Antimony trioxide based flame retardants must also meet the ≤ 1000 ppm threshold requirement.

(3) **MSL, Peak Temp.** - The Moisture Sensitivity Level rating according to the JEDEC industry standard classifications, and peak solder temperature.

(4) There may be additional marking, which relates to the logo, the lot trace code information, or the environmental category on the device.

(5) Multiple Device Markings will be inside parentheses. Only one Device Marking contained in parentheses and separated by a "~" will appear on a device. If a line is indented then it is a continuation of the previous line and the two combined represent the entire Device Marking for that device.

(6) **Lead finish/Ball material** - Orderable Devices may have multiple material finish options. Finish options are separated by a vertical ruled line. Lead finish/Ball material values may wrap to two lines if the finish value exceeds the maximum column width.

Important Information and Disclaimer: The information provided on this page represents TI's knowledge and belief as of the date that it is provided. TI bases its knowledge and belief on information provided by third parties, and makes no representation or warranty as to the accuracy of such information. Efforts are underway to better integrate information from third parties. TI has taken and continues to take reasonable steps to provide representative and accurate information but may not have conducted destructive testing or chemical analysis on incoming materials and chemicals. TI and TI suppliers consider certain information to be proprietary, and thus CAS numbers and other limited information may not be available for release.

In no event shall TI's liability arising out of such information exceed the total purchase price of the TI part(s) at issue in this document sold by TI to Customer on an annual basis.

OTHER QUALIFIED VERSIONS OF TPS3851-Q1 :

- Catalog : [TPS3851](#)

NOTE: Qualified Version Definitions:

- Catalog - TI's standard catalog product

TAPE AND REEL INFORMATION

QUADRANT ASSIGNMENTS FOR PIN 1 ORIENTATION IN TAPE

*All dimensions are nominal

Device	Package Type	Package Drawing	Pins	SPQ	Reel Diameter (mm)	Reel Width W1 (mm)	A0 (mm)	B0 (mm)	K0 (mm)	P1 (mm)	W (mm)	Pin1 Quadrant
TPS3851G18EQDRBRQ1	SON	DRB	8	3000	330.0	12.4	3.3	3.3	1.1	8.0	12.0	Q2
TPS3851G18SQDRBRQ1	SON	DRB	8	3000	330.0	12.4	3.3	3.3	1.1	8.0	12.0	Q2
TPS3851G25EQDRBRQ1	SON	DRB	8	3000	330.0	12.4	3.3	3.3	1.1	8.0	12.0	Q2
TPS3851G25SQDRBRQ1	SON	DRB	8	3000	330.0	12.4	3.3	3.3	1.1	8.0	12.0	Q2
TPS3851G30EQDRBRQ1	SON	DRB	8	3000	330.0	12.4	3.3	3.3	1.1	8.0	12.0	Q2
TPS3851G30SQDRBRQ1	SON	DRB	8	3000	330.0	12.4	3.3	3.3	1.1	8.0	12.0	Q2
TPS3851G33EQDRBRQ1	SON	DRB	8	3000	330.0	12.4	3.3	3.3	1.1	8.0	12.0	Q2
TPS3851G33SQDRBRQ1	SON	DRB	8	3000	330.0	12.4	3.3	3.3	1.1	8.0	12.0	Q2
TPS3851G50EQDRBRQ1	SON	DRB	8	3000	330.0	12.4	3.3	3.3	1.1	8.0	12.0	Q2
TPS3851G50SQDRBRQ1	SON	DRB	8	3000	330.0	12.4	3.3	3.3	1.1	8.0	12.0	Q2
TPS3851H18EQDRBRQ1	SON	DRB	8	3000	330.0	12.4	3.3	3.3	1.1	8.0	12.0	Q2
TPS3851H18SQDRBRQ1	SON	DRB	8	3000	330.0	12.4	3.3	3.3	1.1	8.0	12.0	Q2
TPS3851H25EQDRBRQ1	SON	DRB	8	3000	330.0	12.4	3.3	3.3	1.1	8.0	12.0	Q2
TPS3851H25SQDRBRQ1	SON	DRB	8	3000	330.0	12.4	3.3	3.3	1.1	8.0	12.0	Q2
TPS3851H30EQDRBRQ1	SON	DRB	8	3000	330.0	12.4	3.3	3.3	1.1	8.0	12.0	Q2
TPS3851H30SQDRBRQ1	SON	DRB	8	3000	330.0	12.4	3.3	3.3	1.1	8.0	12.0	Q2

Device	Package Type	Package Drawing	Pins	SPQ	Reel Diameter (mm)	Reel Width W1 (mm)	A0 (mm)	B0 (mm)	K0 (mm)	P1 (mm)	W (mm)	Pin1 Quadrant
TPS3851H33EQDRBRQ1	SON	DRB	8	3000	330.0	12.4	3.3	3.3	1.1	8.0	12.0	Q2
TPS3851H33SQDRBRQ1	SON	DRB	8	3000	330.0	12.4	3.3	3.3	1.1	8.0	12.0	Q2
TPS3851H50EQDRBRQ1	SON	DRB	8	3000	330.0	12.4	3.3	3.3	1.1	8.0	12.0	Q2
TPS3851H50SQDRBRQ1	SON	DRB	8	3000	330.0	12.4	3.3	3.3	1.1	8.0	12.0	Q2

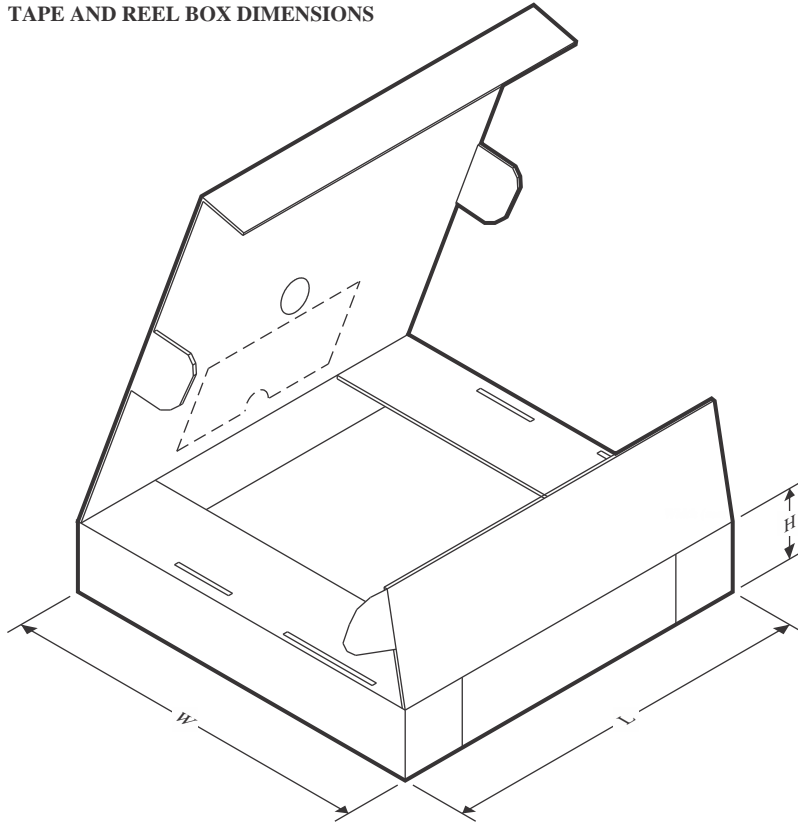
TAPE AND REEL BOX DIMENSIONS

*All dimensions are nominal

Device	Package Type	Package Drawing	Pins	SPQ	Length (mm)	Width (mm)	Height (mm)
TPS3851G18EQDRBRQ1	SON	DRB	8	3000	367.0	367.0	35.0
TPS3851G18SQDRBRQ1	SON	DRB	8	3000	367.0	367.0	35.0
TPS3851G25EQDRBRQ1	SON	DRB	8	3000	367.0	367.0	35.0
TPS3851G25SQDRBRQ1	SON	DRB	8	3000	367.0	367.0	35.0
TPS3851G30EQDRBRQ1	SON	DRB	8	3000	367.0	367.0	35.0
TPS3851G30SQDRBRQ1	SON	DRB	8	3000	367.0	367.0	35.0
TPS3851G33EQDRBRQ1	SON	DRB	8	3000	367.0	367.0	35.0
TPS3851G33SQDRBRQ1	SON	DRB	8	3000	367.0	367.0	35.0
TPS3851G50EQDRBRQ1	SON	DRB	8	3000	367.0	367.0	35.0
TPS3851G50SQDRBRQ1	SON	DRB	8	3000	367.0	367.0	35.0
TPS3851H18EQDRBRQ1	SON	DRB	8	3000	367.0	367.0	35.0
TPS3851H18SQDRBRQ1	SON	DRB	8	3000	367.0	367.0	35.0
TPS3851H25EQDRBRQ1	SON	DRB	8	3000	367.0	367.0	35.0
TPS3851H25SQDRBRQ1	SON	DRB	8	3000	367.0	367.0	35.0
TPS3851H30EQDRBRQ1	SON	DRB	8	3000	367.0	367.0	35.0
TPS3851H30SQDRBRQ1	SON	DRB	8	3000	367.0	367.0	35.0
TPS3851H33EQDRBRQ1	SON	DRB	8	3000	367.0	367.0	35.0
TPS3851H33SQDRBRQ1	SON	DRB	8	3000	367.0	367.0	35.0

Device	Package Type	Package Drawing	Pins	SPQ	Length (mm)	Width (mm)	Height (mm)
TPS3851H50EQDRBRQ1	SON	DRB	8	3000	367.0	367.0	35.0
TPS3851H50SQDRBRQ1	SON	DRB	8	3000	367.0	367.0	35.0

DRB 8

GENERIC PACKAGE VIEW

VSON - 1 mm max height

PLASTIC SMALL OUTLINE - NO LEAD



Images above are just a representation of the package family, actual package may vary.
Refer to the product data sheet for package details.

4203482/L

EXAMPLE STENCIL DESIGN

DRB0008F

VSON - 1 mm max height

PLASTIC SMALL OUTLINE - NO LEAD

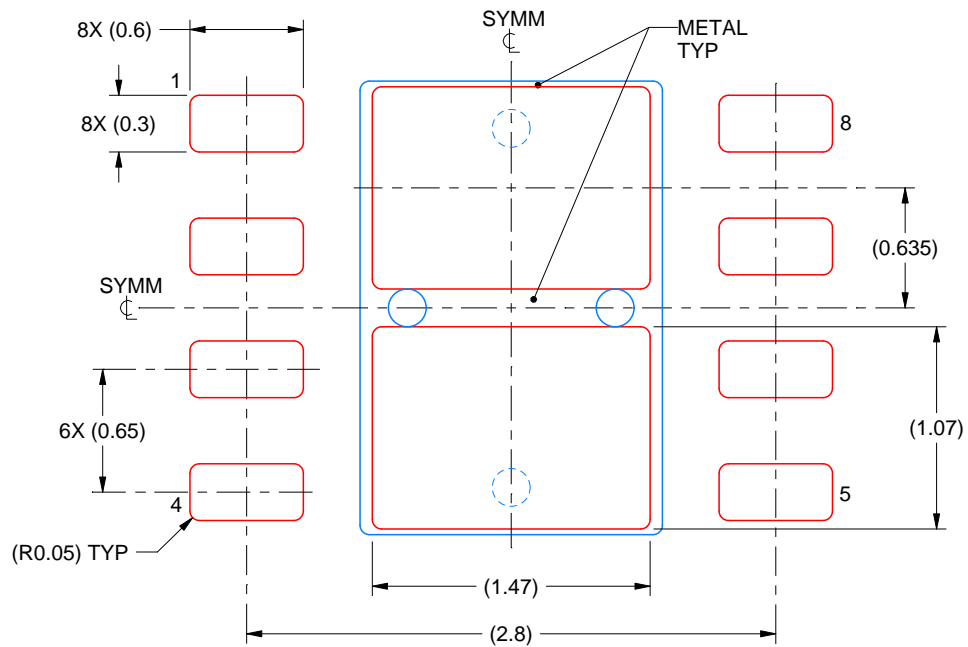

SOLDER PASTE EXAMPLE
BASED ON 0.125 mm THICK STENCIL

EXPOSED PAD
82% PRINTED SOLDER COVERAGE BY AREA
SCALE:25X

4222121/C 10/2016

NOTES: (continued)

6. Laser cutting apertures with trapezoidal walls and rounded corners may offer better paste release. IPC-7525 may have alternate design recommendations.

EXAMPLE BOARD LAYOUT

DRB0008K

VSON - 1 mm max height

PLASTIC SMALL OUTLINE - NO LEAD

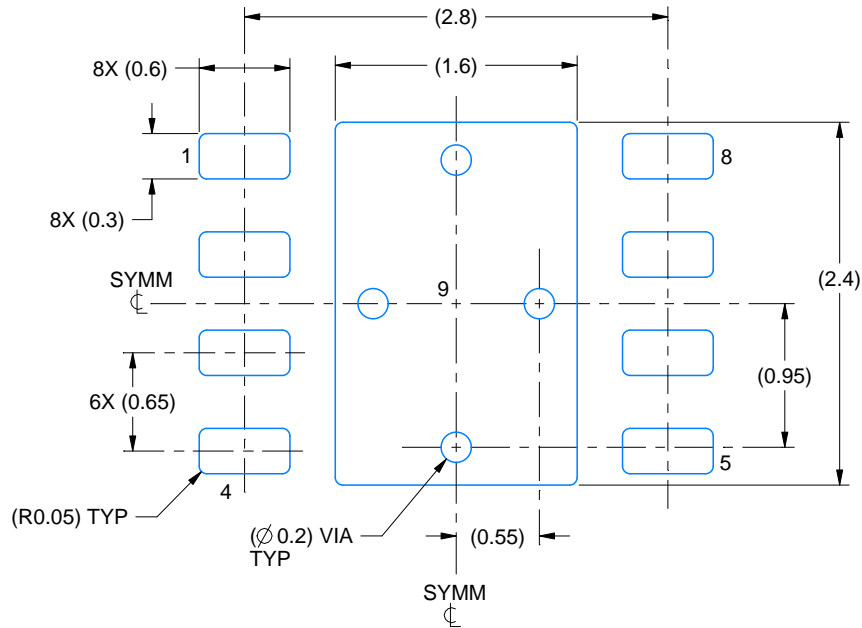

LAND PATTERN EXAMPLE
EXPOSED METAL SHOWN
SCALE:20X

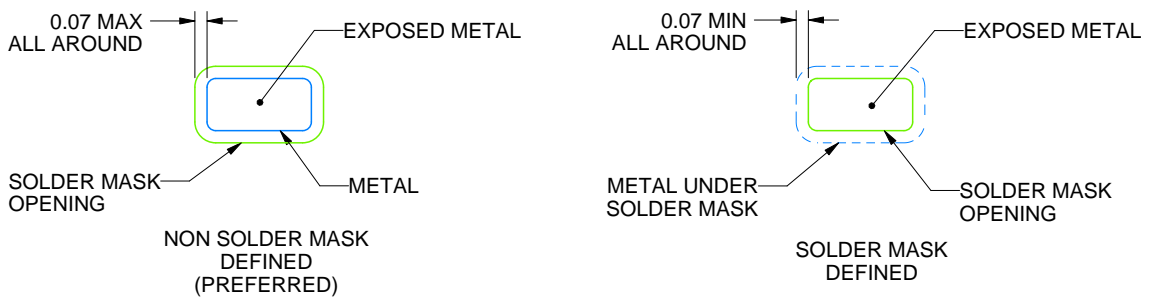

SOLDER MASK DETAILS

4227074/D 08/2022

NOTES: (continued)

4. This package is designed to be soldered to a thermal pad on the board. For more information, see Texas Instruments literature number SLUA271 (www.ti.com/lit/sluea271).
5. Vias are optional depending on application, refer to device data sheet. If any vias are implemented, refer to their locations shown on this view. It is recommended that vias under paste be filled, plugged or tented.

EXAMPLE STENCIL DESIGN

DRB0008K

VSON - 1 mm max height

PLASTIC SMALL OUTLINE - NO LEAD

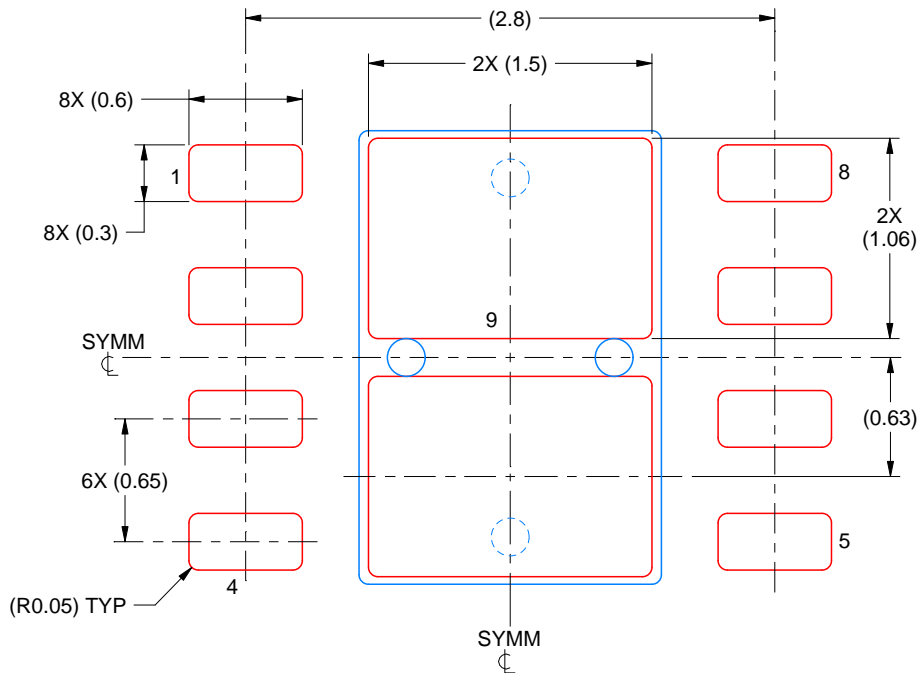

SOLDER PASTE EXAMPLE
BASED ON 0.125 mm THICK STENCIL

EXPOSED PAD 9:
80% PRINTED SOLDER COVERAGE BY AREA
SCALE:25X

4227074/D 08/2022

NOTES: (continued)

6. Laser cutting apertures with trapezoidal walls and rounded corners may offer better paste release. IPC-7525 may have alternate design recommendations.

IMPORTANT NOTICE AND DISCLAIMER

TI PROVIDES TECHNICAL AND RELIABILITY DATA (INCLUDING DATA SHEETS), DESIGN RESOURCES (INCLUDING REFERENCE DESIGNS), APPLICATION OR OTHER DESIGN ADVICE, WEB TOOLS, SAFETY INFORMATION, AND OTHER RESOURCES "AS IS" AND WITH ALL FAULTS, AND DISCLAIMS ALL WARRANTIES, EXPRESS AND IMPLIED, INCLUDING WITHOUT LIMITATION ANY IMPLIED WARRANTIES OF MERCHANTABILITY, FITNESS FOR A PARTICULAR PURPOSE OR NON-INFRINGEMENT OF THIRD PARTY INTELLECTUAL PROPERTY RIGHTS.

These resources are intended for skilled developers designing with TI products. You are solely responsible for (1) selecting the appropriate TI products for your application, (2) designing, validating and testing your application, and (3) ensuring your application meets applicable standards, and any other safety, security, regulatory or other requirements.

These resources are subject to change without notice. TI grants you permission to use these resources only for development of an application that uses the TI products described in the resource. Other reproduction and display of these resources is prohibited. No license is granted to any other TI intellectual property right or to any third party intellectual property right. TI disclaims responsibility for, and you will fully indemnify TI and its representatives against, any claims, damages, costs, losses, and liabilities arising out of your use of these resources.

TI's products are provided subject to [TI's Terms of Sale](#) or other applicable terms available either on [ti.com](https://www.ti.com) or provided in conjunction with such TI products. TI's provision of these resources does not expand or otherwise alter TI's applicable warranties or warranty disclaimers for TI products.

TI objects to and rejects any additional or different terms you may have proposed.

Mailing Address: Texas Instruments, Post Office Box 655303, Dallas, Texas 75265
Copyright © 2023, Texas Instruments Incorporated

Looking for pricing, stock, or lifecycle information?

Click below to explore more details on WIN SOURCE:

 [View STM802SM6E on WIN SOURCE](#)

 [STMicroelectronics](#) Information

Optimize Your Supply Chain with WIN SOURCE Solutions

-  Global Sourcing Solution
-  Obsolete Management
-  Cost Control Management
-  Shortage Management
-  Alternative Solution
-  Excess Inventory Management