



**THE DATASHEET OF
SC431CSQTRT**



POWER MANAGEMENT

Description

The SC431 is a three terminal adjustable shunt regulator with thermal stability guaranteed over temperature. The output voltage can be adjusted to any value from 2.5V (V_{REF}) to 30V with two external resistors. The SC431 has a typical dynamic output impedance of 0.25Ω . Active output circuitry provides a very sharp turn on characteristic, making the SC431 an excellent replacement for zener diodes.

The SC431 shunt regulator is available with four voltage tolerances (0.5%, 1.0% and 2.0% over $T_A = -40^\circ\text{C}$ to $+85^\circ\text{C}$ and 0.5% over $T_A = -40^\circ\text{C}$ to $+125^\circ\text{C}$) and two package options (SOT-23-3 and SO-8). This allows the designer the opportunity to select the optimum combination of cost and performance for their application.

Features

- ◆ Wide operating current range 130 μA to 150mA
- ◆ Low dynamic output impedance $0.25\ \Omega$ typ.
- ◆ Trimmed bandgap design $\pm 0.5\%$
- ◆ Alternate for TL1431, TL431, LM431 & AS431
- ◆ Industrial temperature range
- ◆ Available in SOT-23-3 and SO-8 packages.
Also available in Lead-free, fully WEEE and RoHS compliant.

Applications

- ◆ Linear Regulators
- ◆ Adjustable Supplies
- ◆ Switching Power Supplies
- ◆ Battery Operated Computers
- ◆ Instrumentation
- ◆ Computer Disk Drives

Typical Application Circuit⁽¹⁾⁽²⁾

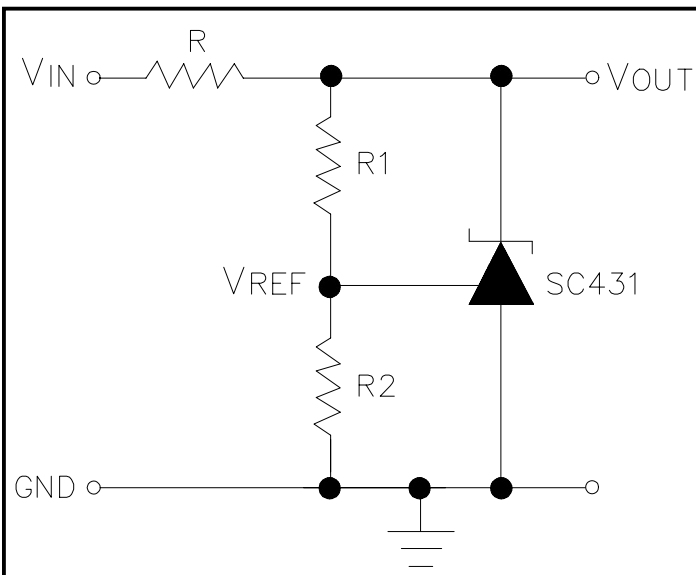

Notes:

- 1) Set V_{OUT} according to the following equation:

$$V_{OUT} = V_{REF} \left(1 + \frac{R1}{R2} \right) + I_{REF} R1$$

- 2) Choose the value for R as follows:

- The maximum limit for R should be such that the cathode current, I_z , is greater than the minimum operating current (130 μA) at $V_{IN(MIN)}$.
- The minimum limit for R should be such that I_z does not exceed 150mA under all load conditions, and the instantaneous turn-on value for I_z does not exceed 200mA. Both of the following conditions must be met:

$$R_{min} \geq \frac{V_{IN(max)}}{200mA} \quad (\text{to limit instantaneous turn-on } I_z)$$

$$R_{min} \geq \frac{V_{IN(max)} - V_{OUT}}{I_{OUT(min)} + 150mA} \quad (\text{to limit } I_z \text{ under normal operating conditions})$$

POWER MANAGEMENT
Absolute Maximum Ratings

Exceeding the specifications below may result in permanent damage to the device, or device malfunction. Operation outside of the parameters specified in the Electrical Characteristics section is not implied.

Parameter	Symbol	Maximum	Units
Cathode Voltage	V_Z	31	V
Continuous Cathode Current	I_Z	150	mA
Reference Input Current	I_{REF}	10	mA
Power Dissipation at $T_A = 25^\circ\text{C}$ SOT-23-3 SO-8	P_D	0.37 0.78	W
Thermal Resistance SOT-23-3 SO-8	θ_{JA}	336 163	$^\circ\text{C/W}$
Operating Ambient Temperature Range SC431Cx-.5, SC431Cx-1, SC431Cx-2 SC431CxQ	T_A	-40 to +85 -40 to +125	$^\circ\text{C}$
Operating Junction Temperature Range	T_J	-40 to +150	$^\circ\text{C}$
Storage Temperature Range	T_{STG}	-65 to +150	$^\circ\text{C}$
Lead Temperature (Soldering) 10 seconds	T_{LEAD}	300	$^\circ\text{C}$
ESD Rating (Human Body Model)	V_{ESD}	2	kV

Electrical Characteristics

Unless specified: $T_A = 25^\circ\text{C}$. Values in **bold** apply over full operating ambient temperature range.

Parameter	Symbol	Condition	SC431Cx-.5, SC431CxQ			SC431Cx-1			Units
			Min	Typ	Max	Min	Typ	Max	
Reference Voltage	V_{REF}	$V_Z = V_{REF}, I_Z = 10\text{mA}^{(1)}$	2.482	2.495	2.507	2.470	2.495	2.520	V
V_{REF} Temp Deviation	V_{DEV}	$V_Z = V_{REF}, I_Z = 10\text{mA}^{(1)}$		8	17		8	25	mV
Ratio of Change in V_{REF} to Change in V_Z	$\frac{\Delta V_{REF}}{\Delta V_Z}$	$I_Z = 10\text{mA}, \Delta V_Z = 10\text{V to } V_{REF}$ $I_Z = 10\text{mA}, \Delta V_Z = 30\text{V to } 10\text{V}$		-0.5 -1.0	-2.7 -2.0		-0.5 -1.0	-2.7 -2.0	mV/V
Reference Input Current	I_{REF}	$R1 = 10\text{k}\Omega, R2 = \infty,$ $I_Z = 10\text{mA}^{(2)}$		0.5	4		0.5	4	μA
I_{REF} Temperature Deviation	$I_{REF(DEV)}$	$R1 = 10\text{k}\Omega, R2 = \infty,$ $I_Z = 10\text{mA}^{(2)}$		0.4	1.2		0.4	1.2	μA
Off-State Cathode Current	$I_{Z(OFF)}$	$V_{REF} = 0\text{V}, V_Z = 30\text{V}^{(3)}$		0.04	0.50		0.04	0.50	μA
Dynamic Output Impedance	r_z	$f < 1\text{kHz}, V_Z = V_{REF}$ $I_Z = 130\mu\text{A to } 100\text{mA}^{(1)}$		0.25	0.50		0.25	0.50	Ω
Minimum Operating Current	$I_{Z(MIN)}$	$V_Z = V_{REF}^{(1)}$			130			130	μA

POWER MANAGEMENT
Electrical Characteristics (Cont.)

 Unless specified: $T_A = 25^\circ\text{C}$. Values in **bold** apply over full operating ambient temperature range.

Parameter	Symbol	Condition	SC431Cx-2			Units
			Min	Typ	Max	
Reference Voltage	V_{REF}	$V_Z = V_{REF}, I_Z = 10\text{mA}^{(1)}$	2.445	2.495	2.545	V
V_{REF} Temp Deviation	V_{DEV}	$V_Z = V_{REF}, I_Z = 10\text{mA}^{(1)}$		15	30	mV
Ratio of Change in V_{REF} to Change in V_Z	$\frac{\Delta V_{REF}}{\Delta V_Z}$	$I_Z = 10\text{mA}, \Delta V_Z = 10\text{V to } V_{REF}$		-0.5	-2.7	mV/V
		$I_Z = 10\text{mA}, \Delta V_Z = 30\text{V to } 10\text{V}$		-1.0	-2.0	
Reference Input Current	I_{REF}	$R1 = 10\text{k}\Omega, R2 = \infty, I_Z = 10\text{mA}^{(2)}$		0.5	4	μA
I_{REF} Temperature Deviation	$I_{REF(DEV)}$	$R1 = 10\text{k}\Omega, R2 = \infty, I_Z = 10\text{mA}^{(2)}$		0.4	1.2	μA
Off-State Cathode Current	$I_{Z(OFF)}$	$V_{REF} = 0\text{V}, V_Z = 30\text{V}^{(3)}$		0.04	0.50	μA
Dynamic Output Impedance	r_z	$f < 1\text{kHz}, V_Z = V_{REF}, I_Z = 130\mu\text{A to } 100\text{mA}^{(1)}$		0.25	0.50	Ω
Minimum Operating Current	$I_{Z(MIN)}$	$V_Z = V_{REF}^{(1)}$			130	μA

Notes:

- (1) See Test Circuit 1 below.
- (2) See Test Circuit 2 below.
- (3) See Test Circuit 3 below.

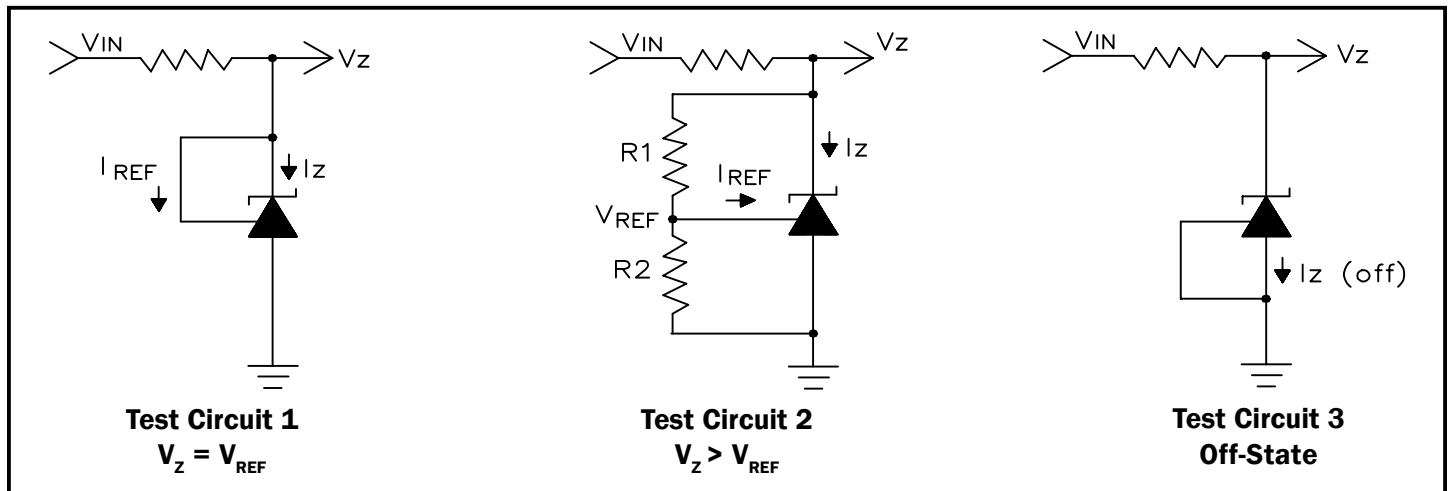
Test Circuits

Recommended Operating Conditions

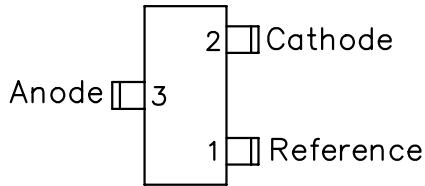
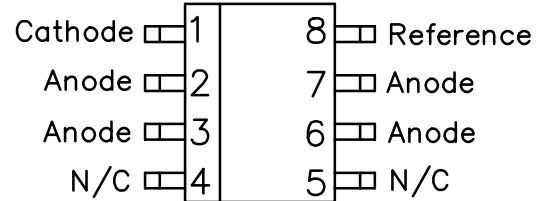
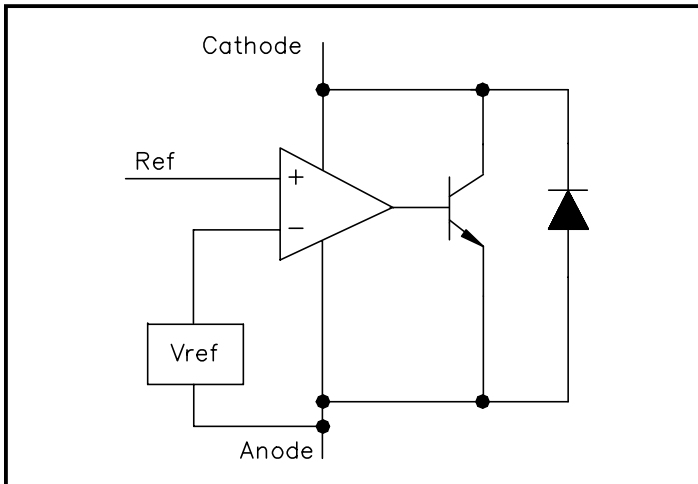
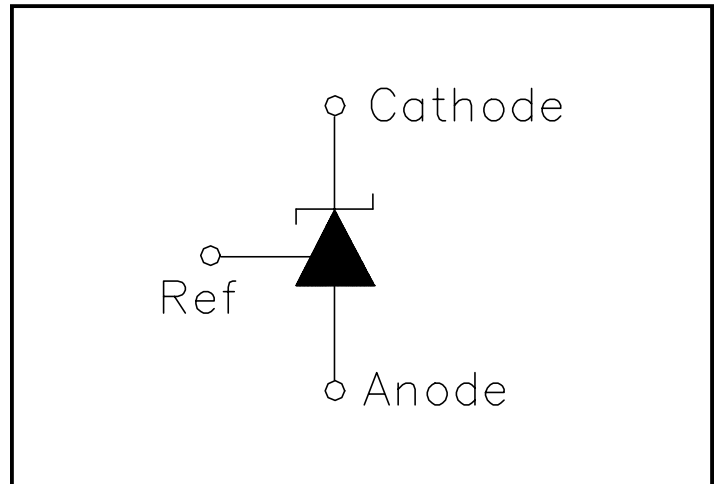
	Min	Max	Symbol
Cathode Voltage, V_Z	V_{REF}	30	V
Cathode Current, I_Z	0.130	150	mA

POWER MANAGEMENT
Pin Configurations
SOT-23-3 (Top View)

SO-8 (Top View)

Block Diagram

Symbol

Ordering Information

Tolerance	0.5%	0.5%	1.0%	2.0%
Ambient Temperature Range	-40°C to +85°C	-40°C to +125°C	-40°C to +85°C	-40°C to +85°C
SOT-23-3 ⁽¹⁾	SC431CSK-.5 TR	SC431CSKQTR	SC431CSK-1.TR	SC431CSK-2.TR
SOT-23-3 ^{(1),(3)}	SC431CSK-.5TRT	SC431CSKQTRT	SC431CSK-1TRT	SC431CSK-2TRT
SO-8 ⁽²⁾	SC431CS-.5 TR	SC431CSQTR	SC431CS-1.TR	SC431CS-2.TR
SO-8 ^{(2),(3)}	SC431CS-.5 TRT	SC431CSQTRT	SC431CS-1.TR	SC431CS-2.TR

Notes:

- (1) Only available in tape and reel packaging. A reel contains 3000 devices.
- (2) Only available in tape and reel packaging. A reel contains 2500 devices.
- (3) "T" at end of part number indicates "lead free". This product is fully WEEE and RoHS compliant.

POWER MANAGEMENT

Marking Information

SOT-23-3 (Top View)

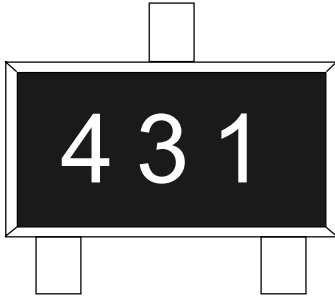

S0-8 (Top View)

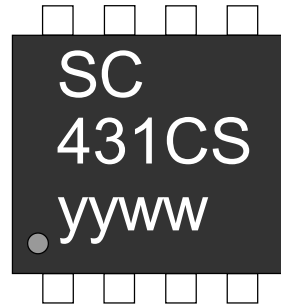

S0-8 (Bottom View)

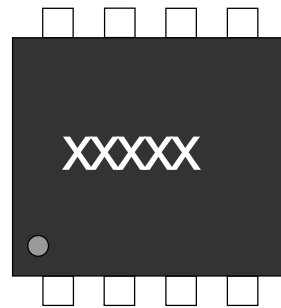

yyww = Datecode (Example: 0008)
xxxxx = Semtech Lot # (Example: 00101)

POWER MANAGEMENT

Typical Characteristics

Cathode Current vs. Cathode Voltage

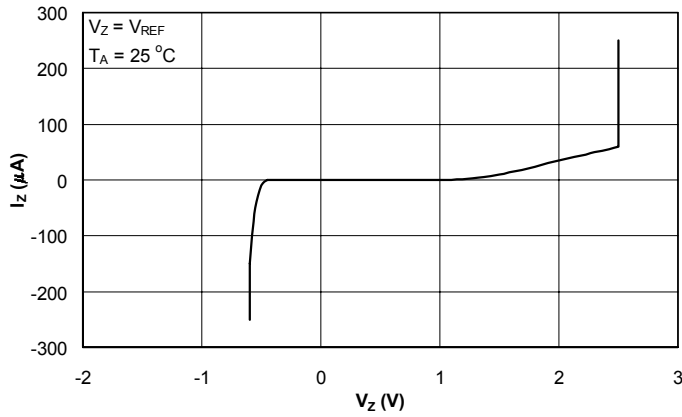

Cathode Current vs. Cathode Voltage

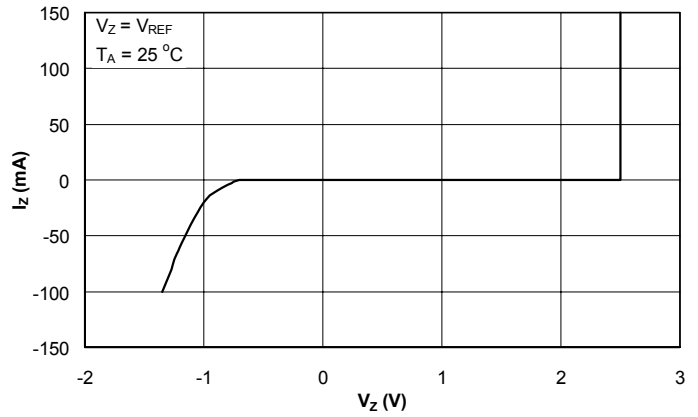

Reference Voltage vs. Junction Temperature

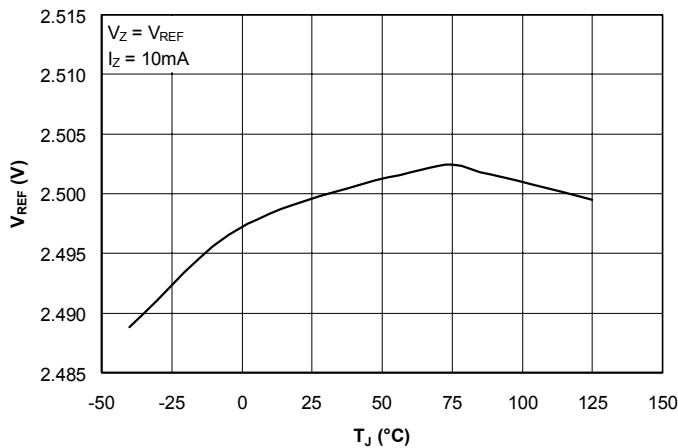

Reference Input Current vs. Junction Temperature

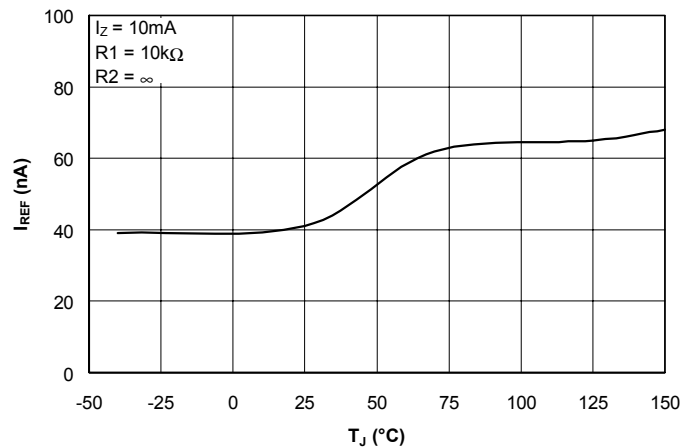

Ratio of Delta Reference Voltage to Delta Cathode Voltage vs. Junction Temperature

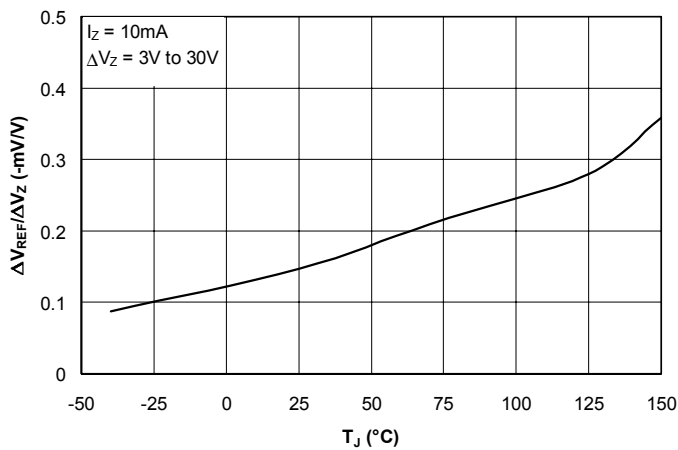

Off-State Cathode Current vs. Junction Temperature

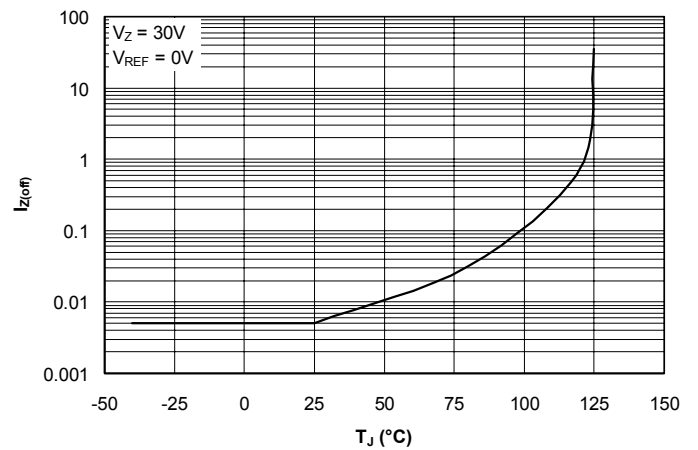

POWER MANAGEMENT

Typical Characteristics (Cont.)

Small-Signal Gain and Phase Shift

vs. Frequency

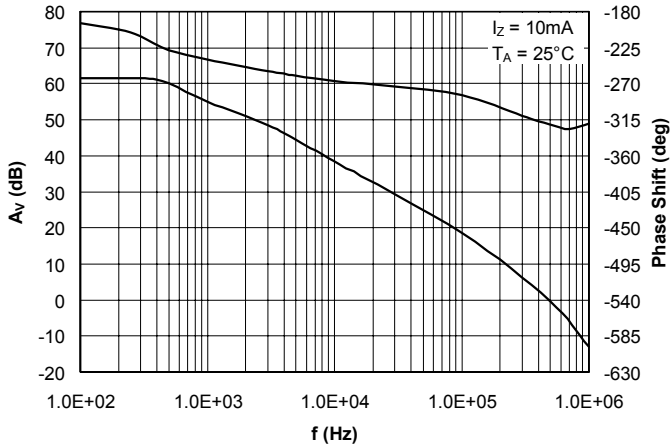

Reference Impedance

vs. Frequency

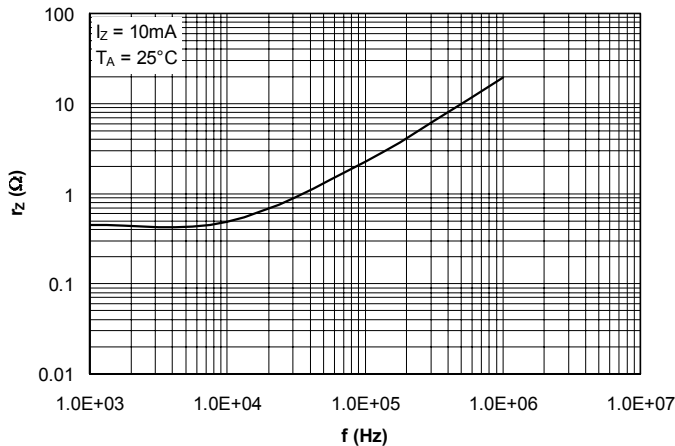

Test Circuit - Small-Signal Gain and Phase

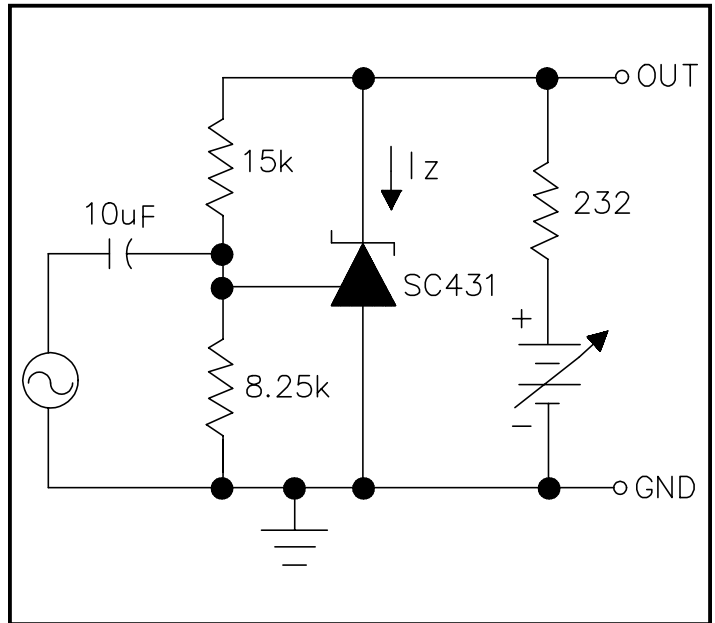

Stability Boundary Condition For Shunt Regulation

vs. Cathode Current and Load Capacitance

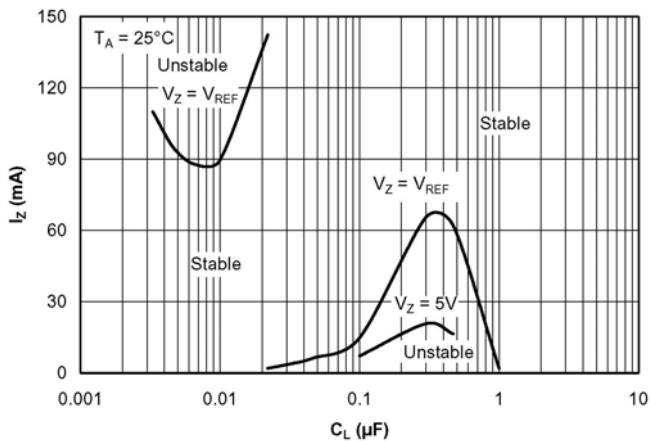

Test Circuit - Stability

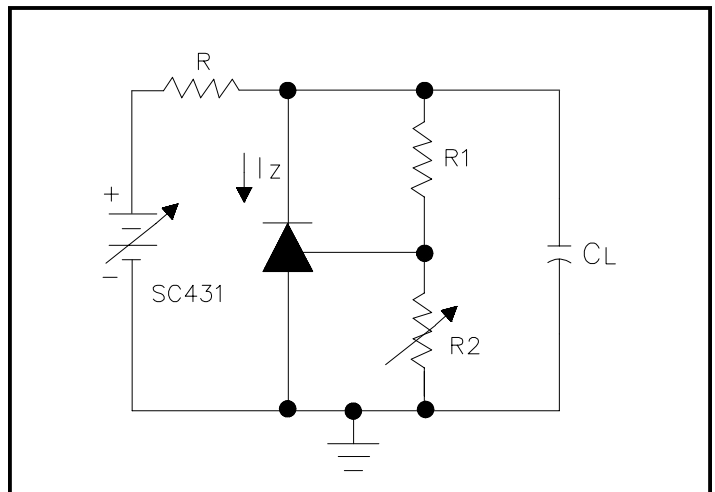

POWER MANAGEMENT

Outline Drawing - SOT-23-3

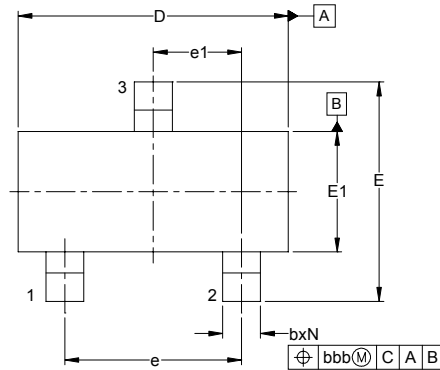

DIM	INCHES			MILLIMETERS		
	MIN	NOM	MAX	MIN	NOM	MAX
A	.035	-	.044	0.89	-	1.12
A1	.000	-	.004	0.01	-	0.10
A2	.035	.037	.040	0.88	0.95	1.02
b	.012	-	.020	0.30	-	0.51
c	.003	-	.007	0.08	-	0.18
D	.110	.114	.120	2.80	2.90	3.04
E	.082	.093	.104	2.10	2.37	2.64
E1	.047	.051	.055	1.20	1.30	1.40
e	.075			1.90 BSC		
e1	.037			0.95 BSC		
L	.015	.020	.024	0.40	0.50	0.60
L1	.022			(0.55)		
N	3			3		
φ	0°	-	8°	0°	-	8°
aaa	.004			0.10		
bbb	.008			0.20		

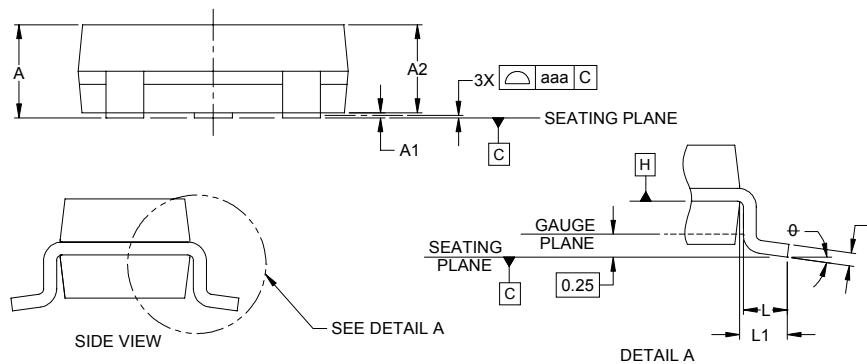

- NOTES:
1. CONTROLLING DIMENSIONS ARE IN MILLIMETERS (ANGLES IN DEGREES).
 2. DATUMS **-A-** AND **-B-** TO BE DETERMINED AT DATUM PLANE **-H-**
 3. DIMENSIONS "E1" AND "D" DO NOT INCLUDE MOLD FLASH, PROTRUSIONS OR GATE BURRS.

Land Pattern - SOT-23-3

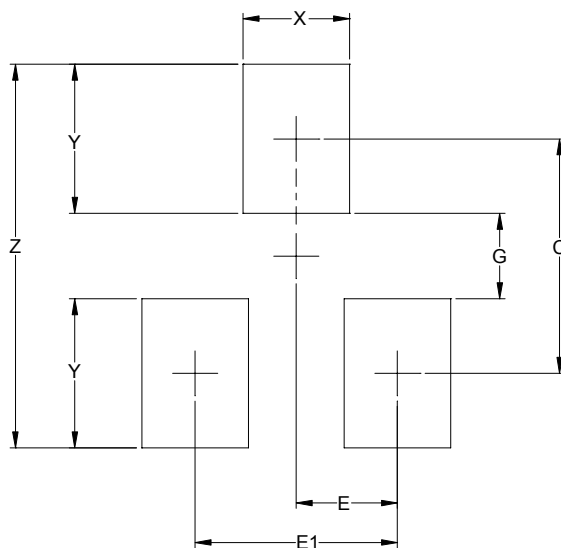

DIM	DIMENSIONS	
	INCHES	MILLIMETERS
C	(.087)	(2.20)
E	.037	0.95
E1	.075	1.90
G	.031	0.80
X	.039	1.00
Y	.055	1.40
Z	.141	3.60

- NOTES:
1. THIS LAND PATTERN IS FOR REFERENCE PURPOSES ONLY CONSULT YOUR MANUFACTURING GROUP TO ENSURE YOUR COMPANY'S MANUFACTURING GUIDELINES ARE MET.
 2. REFERENCE IPC-SM-782A.

POWER MANAGEMENT

Outline Drawing - SO-8

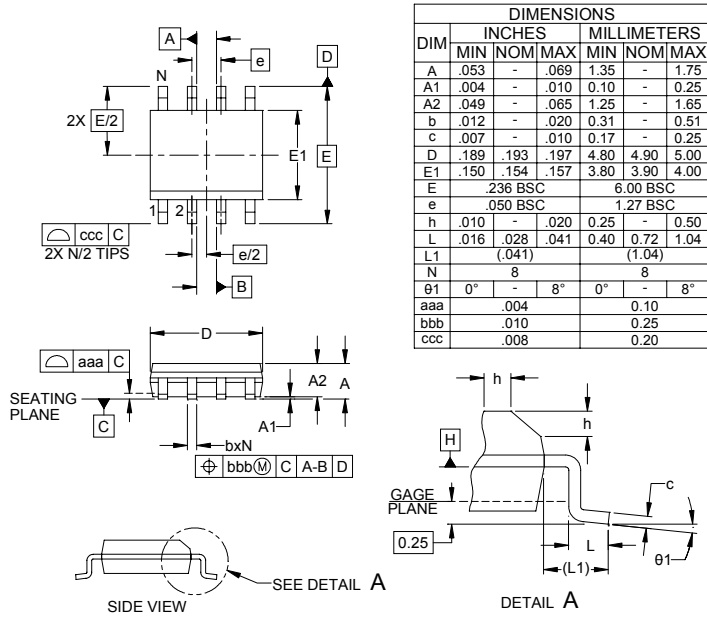

- NOTES:
1. CONTROLLING DIMENSIONS ARE IN MILLIMETERS (ANGLES IN DEGREES).
 2. DATUMS **-A-** AND **-B-** TO BE DETERMINED AT DATUM PLANE **-H-**
 3. DIMENSIONS "E1" AND "D" DO NOT INCLUDE MOLD FLASH, PROTRUSIONS OR GATE BURRS.
 4. REFERENCE JEDEC STD MS-012, VARIATION AA.

Land Pattern - SO-8

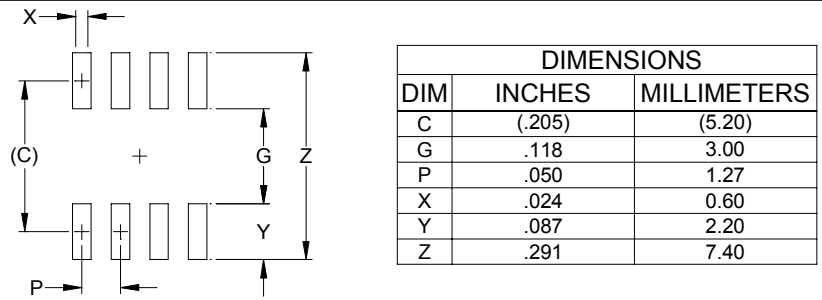

- NOTES:
1. THIS LAND PATTERN IS FOR REFERENCE PURPOSES ONLY. CONSULT YOUR MANUFACTURING GROUP TO ENSURE YOUR COMPANY'S MANUFACTURING GUIDELINES ARE MET.
 2. REFERENCE IPC-SM-782A, RLP NO. 300A.

Contact Information

Semtech Corporation
 Power Management Products Division
 200 Flynn Road, Camarillo, CA 93012
 Phone: (805)498-2111 FAX (805)498-3804

Looking for pricing, stock, or lifecycle information?

Click below to explore more details on WIN SOURCE:

-  [View SC431CSQTRT on WIN SOURCE](#)
-  [Semtech Corporation](#) Information

Optimize Your Supply Chain with WIN SOURCE Solutions

-  Global Sourcing Solution
-  Obsolete Management
-  Cost Control Management
-  Shortage Management
-  Alternative Solution
-  Excess Inventory Management