



**THE DATASHEET OF  
CY7C1357C-100AXCT**



# 9-Mbit (256K x 36/512K x 18) Flow-Through SRAM with NoBL™ Architecture

## Features

- **No Bus Latency™ (NoBL™) architecture eliminates dead cycles between write and read cycles**
- **Can support up to 133-MHz bus operations with zero wait states**
  - Data is transferred on every clock
- **Pin compatible and functionally equivalent to ZBT™ devices**
- **Internally self-timed output buffer control to eliminate the need to use OE**
- **Registered inputs for flow-through operation**
- **Byte Write capability**
- **3.3V/2.5V I/O power supply (V<sub>DDQ</sub>)**
- **Fast clock-to-output times**
  - 6.5 ns (for 133-MHz device)
- **Clock Enable (CEN) pin to enable clock and suspend operation**
- **Synchronous self-timed writes**
- **Asynchronous Output Enable**
- **Available in JEDEC-standard and lead-free 100-Pin TQFP, lead-free and non lead-free 119-Ball BGA package and 165-Ball FBGA package**
- **Three chip enables for simple depth expansion.**
- **Automatic Power-down feature available using ZZ mode or CE deselect**
- **IEEE 1149.1 JTAG-Compatible Boundary Scan**
- **Burst Capability—linear or interleaved burst order**
- **Low standby power**

## Functional Description<sup>[1]</sup>

The CY7C1355C/CY7C1357C is a 3.3V, 256K x 36/512K x 18 Synchronous Flow-through Burst SRAM designed specifically to support unlimited true back-to-back Read/Write operations without the insertion of wait states. The CY7C1355C/CY7C1357C is equipped with the advanced No Bus Latency (NoBL) logic required to enable consecutive Read/Write operations with data being transferred on every clock cycle. This feature dramatically improves the throughput of data through the SRAM, especially in systems that require frequent Write-Read transitions.

All synchronous inputs pass through input registers controlled by the rising edge of the clock. The clock input is qualified by the Clock Enable ( $\overline{\text{CEN}}$ ) signal, which when deasserted suspends operation and extends the previous clock cycle. Maximum access delay from the clock rise is 6.5 ns (133-MHz device).

Write operations are controlled by the two or four Byte Write Select ( $\overline{\text{BW}}_X$ ) and a Write Enable ( $\overline{\text{WE}}$ ) input. All writes are conducted with on-chip synchronous self-timed write circuitry.

Three synchronous Chip Enables ( $\overline{\text{CE}}_1$ ,  $\overline{\text{CE}}_2$ ,  $\overline{\text{CE}}_3$ ) and an asynchronous Output Enable ( $\overline{\text{OE}}$ ) provide for easy bank selection and output tri-state control. In order to avoid bus contention, the output drivers are synchronously tri-stated during the data portion of a write sequence.

## Selection Guide

|                              | 133 MHz | 100 MHz | Unit |
|------------------------------|---------|---------|------|
| Maximum Access Time          | 6.5     | 7.5     | ns   |
| Maximum Operating Current    | 250     | 180     | mA   |
| Maximum CMOS Standby Current | 40      | 40      | mA   |

### Note:

1. For best-practices recommendations, please refer to the Cypress application note *System Design Guidelines* on [www.cypress.com](http://www.cypress.com).

**Logic Block Diagram – CY7C1355C (256K x 36)**

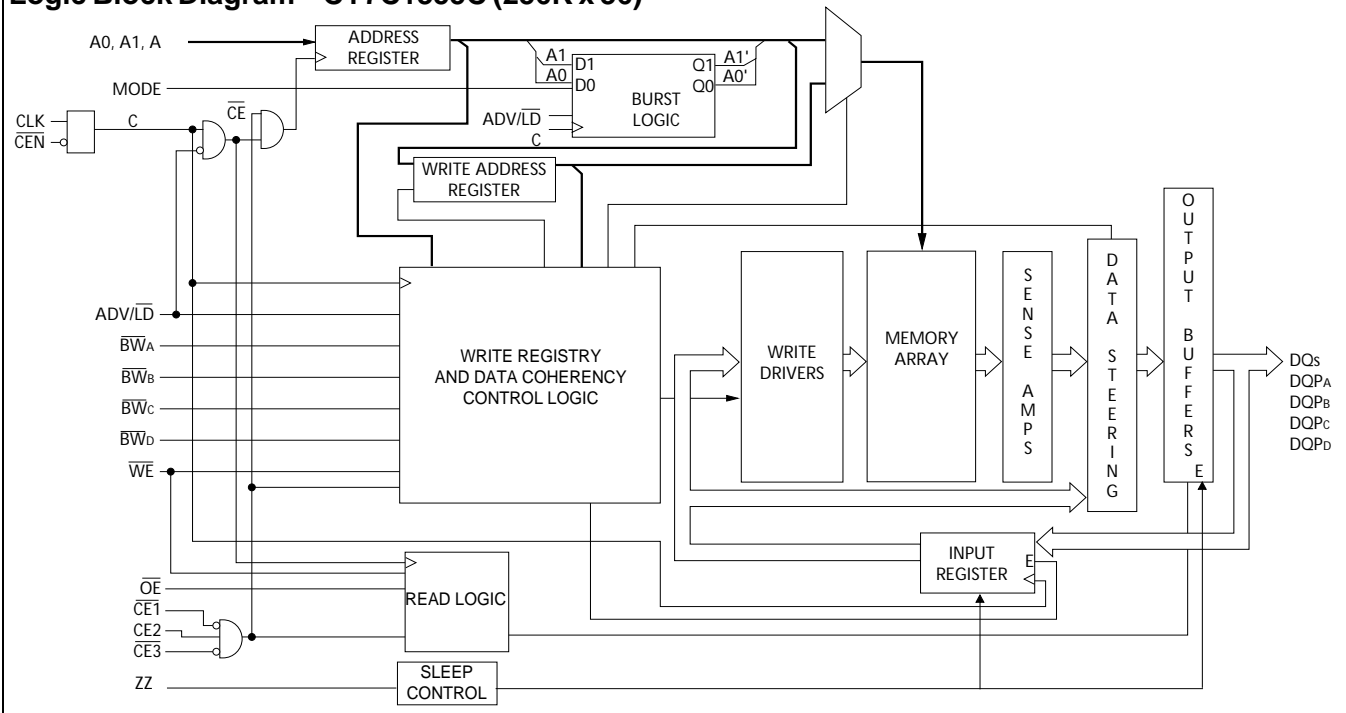

**Logic Block Diagram – CY7C1357C (512K x 18)**

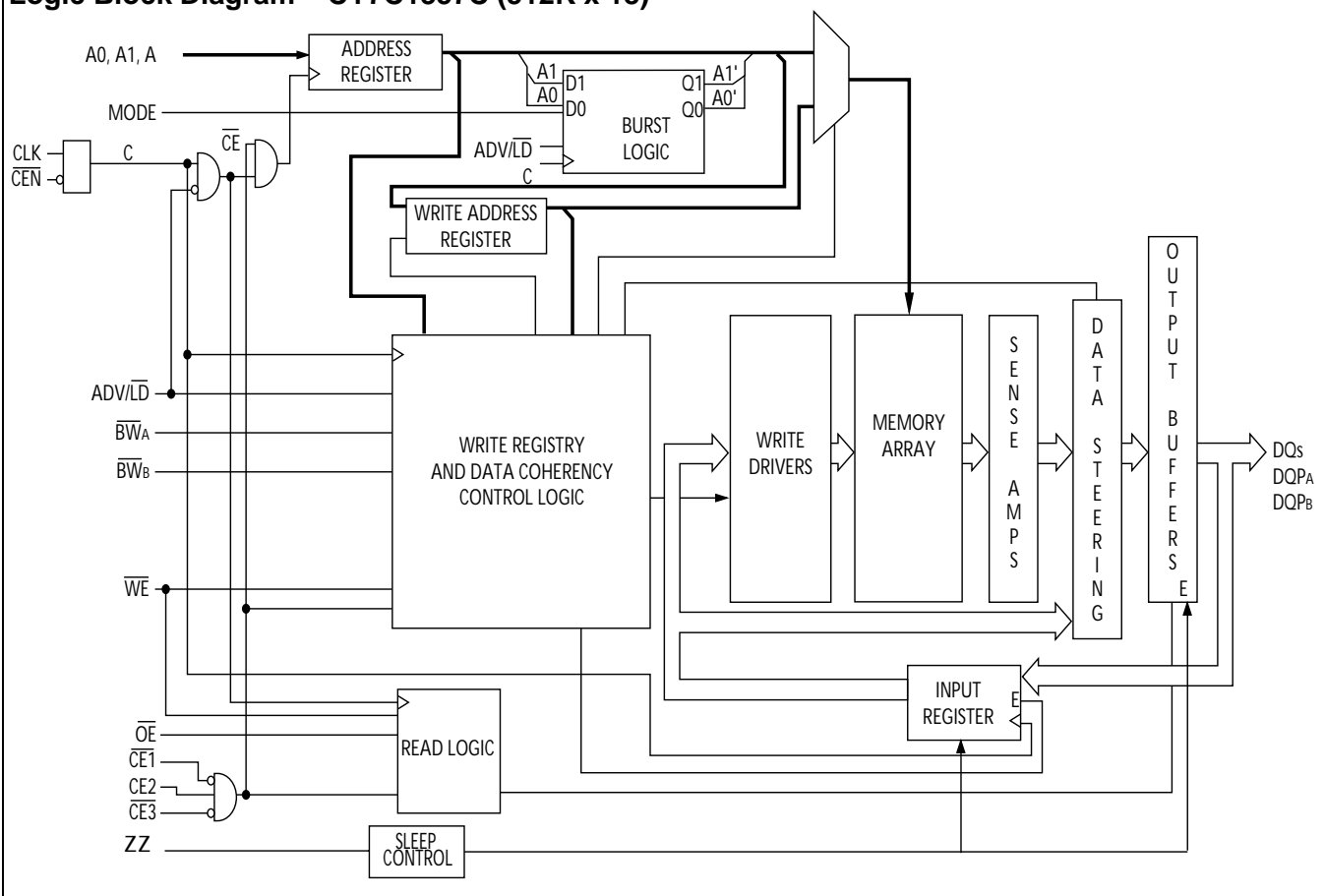

**Pin Configurations**

**100-Pin TQFP Pinout**

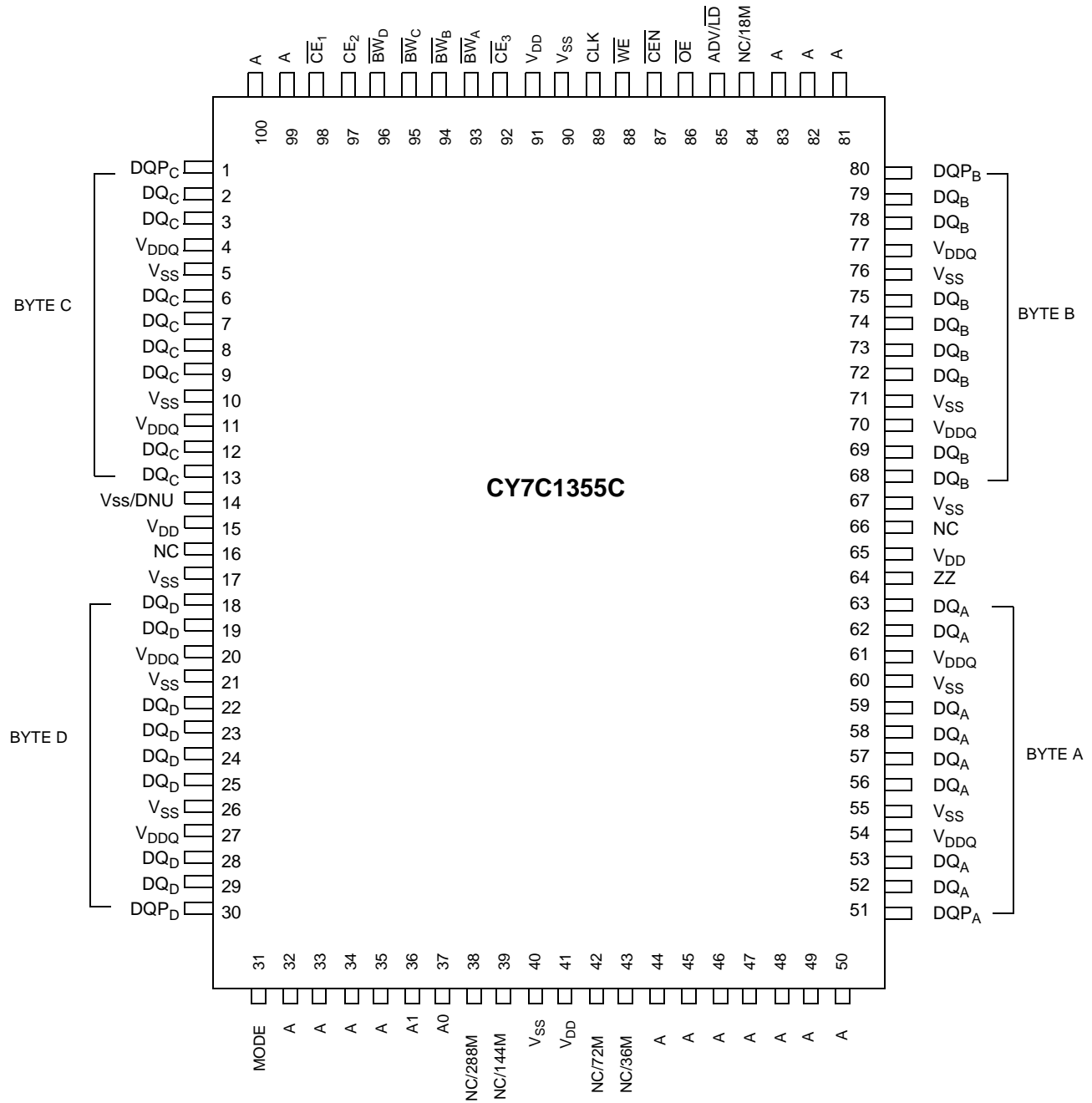

**Pin Configurations** (continued)

**100-Pin TQFP Pinout**

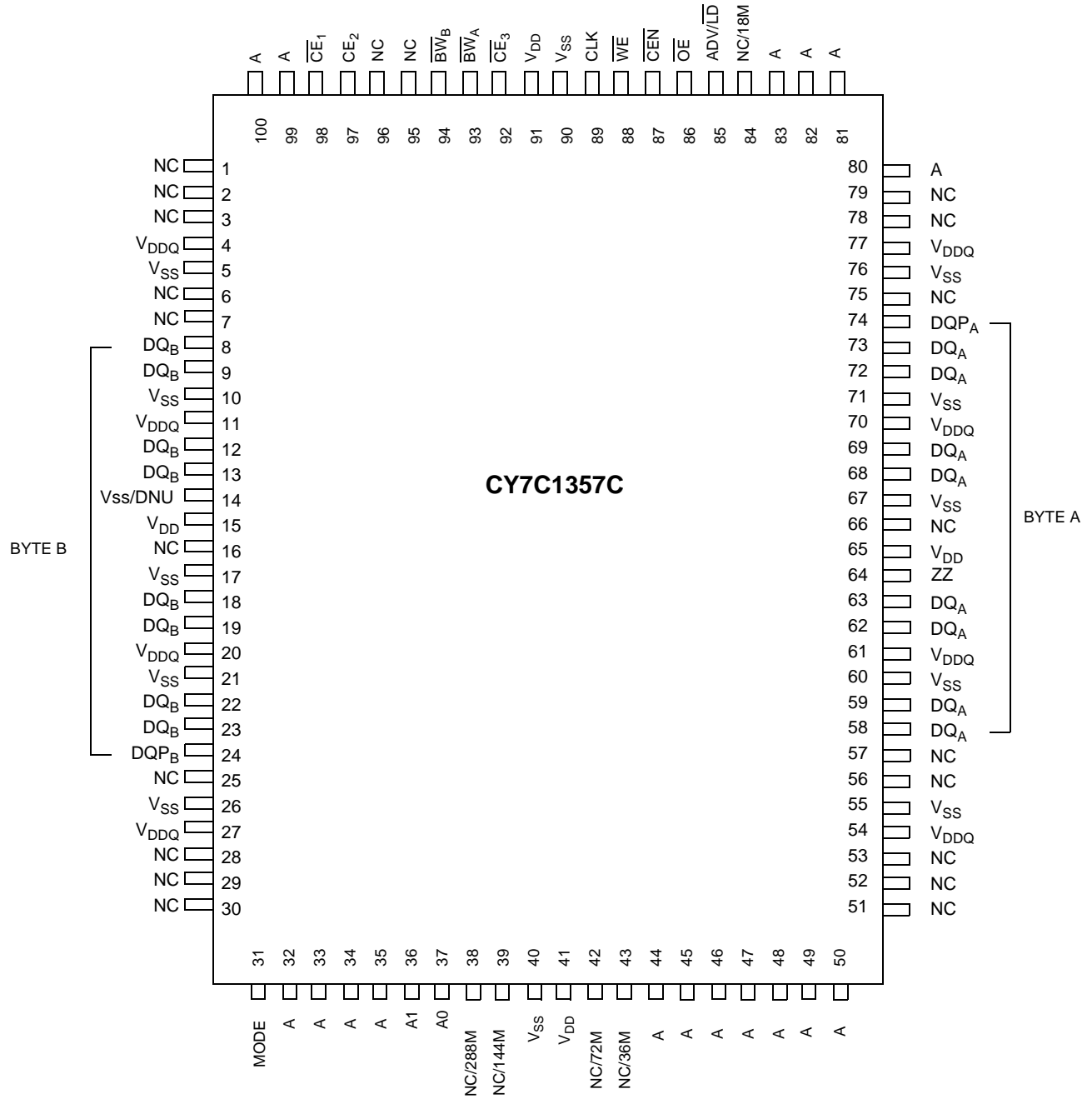

**Pin Configurations** (continued)

**119-Ball BGA Pinout (3 Chip Enables with JTAG)**

**CY7C1355C (256K x 36)**

|          | 1                | 2                | 3               | 4               | 5               | 6                | 7                |
|----------|------------------|------------------|-----------------|-----------------|-----------------|------------------|------------------|
| <b>A</b> | V <sub>DDQ</sub> | A                | A               | NC/18M          | A               | A                | V <sub>DDQ</sub> |
| <b>B</b> | NC/576M          | CE <sub>2</sub>  | A               | ADV/LD          | A               | CE <sub>3</sub>  | NC               |
| <b>C</b> | NC/1G            | A                | A               | V <sub>DD</sub> | A               | A                | NC               |
| <b>D</b> | DQ <sub>C</sub>  | DQP <sub>C</sub> | V <sub>SS</sub> | NC              | V <sub>SS</sub> | DQP <sub>B</sub> | DQ <sub>B</sub>  |
| <b>E</b> | DQ <sub>C</sub>  | DQ <sub>C</sub>  | V <sub>SS</sub> | CE <sub>1</sub> | V <sub>SS</sub> | DQ <sub>B</sub>  | DQ <sub>B</sub>  |
| <b>F</b> | V <sub>DDQ</sub> | DQ <sub>C</sub>  | V <sub>SS</sub> | OE              | V <sub>SS</sub> | DQ <sub>B</sub>  | V <sub>DDQ</sub> |
| <b>G</b> | DQ <sub>C</sub>  | DQ <sub>C</sub>  | BW <sub>C</sub> | A               | BW <sub>B</sub> | DQ <sub>B</sub>  | DQ <sub>B</sub>  |
| <b>H</b> | DQ <sub>C</sub>  | DQ <sub>C</sub>  | V <sub>SS</sub> | WE              | V <sub>SS</sub> | DQ <sub>B</sub>  | DQ <sub>B</sub>  |
| <b>J</b> | V <sub>DDQ</sub> | V <sub>DD</sub>  | NC              | V <sub>DD</sub> | NC              | V <sub>DD</sub>  | V <sub>DDQ</sub> |
| <b>K</b> | DQ <sub>D</sub>  | DQ <sub>D</sub>  | V <sub>SS</sub> | CLK             | V <sub>SS</sub> | DQ <sub>A</sub>  | DQ <sub>A</sub>  |
| <b>L</b> | DQ <sub>D</sub>  | DQ <sub>D</sub>  | BW <sub>D</sub> | NC              | BW <sub>A</sub> | DQ <sub>A</sub>  | DQ <sub>A</sub>  |
| <b>M</b> | V <sub>DDQ</sub> | DQ <sub>D</sub>  | V <sub>SS</sub> | CEN             | V <sub>SS</sub> | DQ <sub>A</sub>  | V <sub>DDQ</sub> |
| <b>N</b> | DQ <sub>D</sub>  | DQ <sub>D</sub>  | V <sub>SS</sub> | A1              | V <sub>SS</sub> | DQ <sub>A</sub>  | DQ <sub>A</sub>  |
| <b>P</b> | DQ <sub>D</sub>  | DQP <sub>D</sub> | V <sub>SS</sub> | A0              | V <sub>SS</sub> | DQP <sub>A</sub> | DQ <sub>A</sub>  |
| <b>R</b> | NC/144M          | A                | MODE            | V <sub>DD</sub> | NC              | A                | NC/288M          |
| <b>T</b> | NC               | NC/72M           | A               | A               | A               | NC/36M           | ZZ               |
| <b>U</b> | V <sub>DDQ</sub> | TMS              | TDI             | TCK             | TDO             | NC               | V <sub>DDQ</sub> |

**CY7C1357C (512K x 18)**

|          | 1                | 2                | 3               | 4               | 5               | 6                | 7                |
|----------|------------------|------------------|-----------------|-----------------|-----------------|------------------|------------------|
| <b>A</b> | V <sub>DDQ</sub> | A                | A               | NC/18M          | A               | A                | V <sub>DDQ</sub> |
| <b>B</b> | NC/576M          | CE <sub>2</sub>  | A               | ADV/LD          | A               | CE <sub>3</sub>  | NC               |
| <b>C</b> | NC/1G            | A                | A               | V <sub>DD</sub> | A               | A                | NC               |
| <b>D</b> | DQ <sub>B</sub>  | NC               | V <sub>SS</sub> | NC              | V <sub>SS</sub> | DQP <sub>A</sub> | NC               |
| <b>E</b> | NC               | DQ <sub>B</sub>  | V <sub>SS</sub> | CE <sub>1</sub> | V <sub>SS</sub> | NC               | DQ <sub>A</sub>  |
| <b>F</b> | V <sub>DDQ</sub> | NC               | V <sub>SS</sub> | OE              | V <sub>SS</sub> | DQ <sub>A</sub>  | V <sub>DDQ</sub> |
| <b>G</b> | NC               | DQ <sub>B</sub>  | BW <sub>B</sub> | A               | V <sub>SS</sub> | NC               | DQ <sub>A</sub>  |
| <b>H</b> | DQ <sub>B</sub>  | NC               | V <sub>SS</sub> | WE              | V <sub>SS</sub> | DQ <sub>A</sub>  | NC               |
| <b>J</b> | V <sub>DDQ</sub> | V <sub>DD</sub>  | NC              | V <sub>DD</sub> | NC              | V <sub>DD</sub>  | V <sub>DDQ</sub> |
| <b>K</b> | NC               | DQ <sub>B</sub>  | V <sub>SS</sub> | CLK             | V <sub>SS</sub> | NC               | DQ <sub>A</sub>  |
| <b>L</b> | DQ <sub>B</sub>  | NC               | V <sub>SS</sub> | NC              | BW <sub>A</sub> | DQ <sub>A</sub>  | NC               |
| <b>M</b> | V <sub>DDQ</sub> | DQ <sub>B</sub>  | V <sub>SS</sub> | CEN             | V <sub>SS</sub> | NC               | V <sub>DDQ</sub> |
| <b>N</b> | DQ <sub>B</sub>  | NC               | V <sub>SS</sub> | A1              | V <sub>SS</sub> | DQ <sub>A</sub>  | NC               |
| <b>P</b> | NC               | DQP <sub>B</sub> | V <sub>SS</sub> | A0              | V <sub>SS</sub> | NC               | DQ <sub>A</sub>  |
| <b>R</b> | NC/144M          | A                | MODE            | V <sub>DD</sub> | NC              | A                | NC/288M          |
| <b>T</b> | NC/72M           | A                | A               | NC/36M          | A               | A                | ZZ               |
| <b>U</b> | V <sub>DDQ</sub> | TMS              | TDI             | TCK             | TDO             | NC               | V <sub>DDQ</sub> |

**Pin Configurations** (continued)

**165-Ball FBGA Pinout (3 Chip enable with JTAG)**  
**CY7C1355C (256K x 36)**

|          | 1                | 2               | 3                 | 4                 | 5                 | 6                 | 7                | 8               | 9                | 10              | 11               |
|----------|------------------|-----------------|-------------------|-------------------|-------------------|-------------------|------------------|-----------------|------------------|-----------------|------------------|
| <b>A</b> | NC/576M          | A               | $\overline{CE}_1$ | $\overline{BW}_C$ | $\overline{BW}_B$ | $\overline{CE}_3$ | $\overline{CEN}$ | ADV/LD          | A                | A               | NC               |
| <b>B</b> | NC/1G            | A               | CE2               | $\overline{BW}_D$ | $\overline{BW}_A$ | CLK               | $\overline{WE}$  | $\overline{OE}$ | NC/18M           | A               | NC               |
| <b>C</b> | DQP <sub>C</sub> | NC              | V <sub>DDQ</sub>  | V <sub>SS</sub>   | V <sub>SS</sub>   | V <sub>SS</sub>   | V <sub>SS</sub>  | V <sub>SS</sub> | V <sub>DDQ</sub> | NC              | DQP <sub>B</sub> |
| <b>D</b> | DQ <sub>C</sub>  | DQ <sub>C</sub> | V <sub>DDQ</sub>  | V <sub>DD</sub>   | V <sub>SS</sub>   | V <sub>SS</sub>   | V <sub>SS</sub>  | V <sub>DD</sub> | V <sub>DDQ</sub> | DQ <sub>B</sub> | DQ <sub>B</sub>  |
| <b>E</b> | DQ <sub>C</sub>  | DQ <sub>C</sub> | V <sub>DDQ</sub>  | V <sub>DD</sub>   | V <sub>SS</sub>   | V <sub>SS</sub>   | V <sub>SS</sub>  | V <sub>DD</sub> | V <sub>DDQ</sub> | DQ <sub>B</sub> | DQ <sub>B</sub>  |
| <b>F</b> | DQ <sub>C</sub>  | DQ <sub>C</sub> | V <sub>DDQ</sub>  | V <sub>DD</sub>   | V <sub>SS</sub>   | V <sub>SS</sub>   | V <sub>SS</sub>  | V <sub>DD</sub> | V <sub>DDQ</sub> | DQ <sub>B</sub> | DQ <sub>B</sub>  |
| <b>G</b> | DQ <sub>C</sub>  | DQ <sub>C</sub> | V <sub>DDQ</sub>  | V <sub>DD</sub>   | V <sub>SS</sub>   | V <sub>SS</sub>   | V <sub>SS</sub>  | V <sub>DD</sub> | V <sub>DDQ</sub> | DQ <sub>B</sub> | DQ <sub>B</sub>  |
| <b>H</b> | NC               | NC              | NC                | V <sub>DD</sub>   | V <sub>SS</sub>   | V <sub>SS</sub>   | V <sub>SS</sub>  | V <sub>DD</sub> | NC               | NC              | ZZ               |
| <b>J</b> | DQ <sub>D</sub>  | DQ <sub>D</sub> | V <sub>DDQ</sub>  | V <sub>DD</sub>   | V <sub>SS</sub>   | V <sub>SS</sub>   | V <sub>SS</sub>  | V <sub>DD</sub> | V <sub>DDQ</sub> | DQ <sub>A</sub> | DQ <sub>A</sub>  |
| <b>K</b> | DQ <sub>D</sub>  | DQ <sub>D</sub> | V <sub>DDQ</sub>  | V <sub>DD</sub>   | V <sub>SS</sub>   | V <sub>SS</sub>   | V <sub>SS</sub>  | V <sub>DD</sub> | V <sub>DDQ</sub> | DQ <sub>A</sub> | DQ <sub>A</sub>  |
| <b>L</b> | DQ <sub>D</sub>  | DQ <sub>D</sub> | V <sub>DDQ</sub>  | V <sub>DD</sub>   | V <sub>SS</sub>   | V <sub>SS</sub>   | V <sub>SS</sub>  | V <sub>DD</sub> | V <sub>DDQ</sub> | DQ <sub>A</sub> | DQ <sub>A</sub>  |
| <b>M</b> | DQ <sub>D</sub>  | DQ <sub>D</sub> | V <sub>DDQ</sub>  | V <sub>DD</sub>   | V <sub>SS</sub>   | V <sub>SS</sub>   | V <sub>SS</sub>  | V <sub>DD</sub> | V <sub>DDQ</sub> | DQ <sub>A</sub> | DQ <sub>A</sub>  |
| <b>N</b> | DQP <sub>D</sub> | NC              | V <sub>DDQ</sub>  | V <sub>SS</sub>   | NC                | NC                | NC               | V <sub>SS</sub> | V <sub>DDQ</sub> | NC              | DQP <sub>A</sub> |
| <b>P</b> | NC/144M          | NC/72M          | A                 | A                 | TDI               | A1                | TDO              | A               | A                | A               | NC/288M          |
| <b>R</b> | MODE             | NC/36M          | A                 | A                 | TMS               | A0                | TCK              | A               | A                | A               | A                |

**CY7C1357C (512K x 18)**

|          | 1                | 2               | 3                 | 4                 | 5                 | 6                 | 7                | 8               | 9                | 10              | 11               |
|----------|------------------|-----------------|-------------------|-------------------|-------------------|-------------------|------------------|-----------------|------------------|-----------------|------------------|
| <b>A</b> | NC/576M          | A               | $\overline{CE}_1$ | $\overline{BW}_B$ | NC                | $\overline{CE}_3$ | $\overline{CEN}$ | ADV/LD          | A                | A               | A                |
| <b>B</b> | NC/1G            | A               | CE2               | NC                | $\overline{BW}_A$ | CLK               | $\overline{WE}$  | $\overline{OE}$ | NC/18M           | A               | NC               |
| <b>C</b> | NC               | NC              | V <sub>DDQ</sub>  | V <sub>SS</sub>   | V <sub>SS</sub>   | V <sub>SS</sub>   | V <sub>SS</sub>  | V <sub>SS</sub> | V <sub>DDQ</sub> | NC              | DQP <sub>A</sub> |
| <b>D</b> | NC               | DQ <sub>B</sub> | V <sub>DDQ</sub>  | V <sub>DD</sub>   | V <sub>SS</sub>   | V <sub>SS</sub>   | V <sub>SS</sub>  | V <sub>DD</sub> | V <sub>DDQ</sub> | NC              | DQ <sub>A</sub>  |
| <b>E</b> | NC               | DQ <sub>B</sub> | V <sub>DDQ</sub>  | V <sub>DD</sub>   | V <sub>SS</sub>   | V <sub>SS</sub>   | V <sub>SS</sub>  | V <sub>DD</sub> | V <sub>DDQ</sub> | NC              | DQ <sub>A</sub>  |
| <b>F</b> | NC               | DQ <sub>B</sub> | V <sub>DDQ</sub>  | V <sub>DD</sub>   | V <sub>SS</sub>   | V <sub>SS</sub>   | V <sub>SS</sub>  | V <sub>DD</sub> | V <sub>DDQ</sub> | NC              | DQ <sub>A</sub>  |
| <b>G</b> | NC               | DQ <sub>B</sub> | V <sub>DDQ</sub>  | V <sub>DD</sub>   | V <sub>SS</sub>   | V <sub>SS</sub>   | V <sub>SS</sub>  | V <sub>DD</sub> | V <sub>DDQ</sub> | NC              | DQ <sub>A</sub>  |
| <b>H</b> | NC               | NC              | NC                | V <sub>DD</sub>   | V <sub>SS</sub>   | V <sub>SS</sub>   | V <sub>SS</sub>  | V <sub>DD</sub> | NC               | NC              | ZZ               |
| <b>J</b> | DQ <sub>B</sub>  | NC              | V <sub>DDQ</sub>  | V <sub>DD</sub>   | V <sub>SS</sub>   | V <sub>SS</sub>   | V <sub>SS</sub>  | V <sub>DD</sub> | V <sub>DDQ</sub> | DQ <sub>A</sub> | NC               |
| <b>K</b> | DQ <sub>B</sub>  | NC              | V <sub>DDQ</sub>  | V <sub>DD</sub>   | V <sub>SS</sub>   | V <sub>SS</sub>   | V <sub>SS</sub>  | V <sub>DD</sub> | V <sub>DDQ</sub> | DQ <sub>A</sub> | NC               |
| <b>L</b> | DQ <sub>B</sub>  | NC              | V <sub>DDQ</sub>  | V <sub>DD</sub>   | V <sub>SS</sub>   | V <sub>SS</sub>   | V <sub>SS</sub>  | V <sub>DD</sub> | V <sub>DDQ</sub> | DQ <sub>A</sub> | NC               |
| <b>M</b> | DQ <sub>B</sub>  | NC              | V <sub>DDQ</sub>  | V <sub>DD</sub>   | V <sub>SS</sub>   | V <sub>SS</sub>   | V <sub>SS</sub>  | V <sub>DD</sub> | V <sub>DDQ</sub> | DQ <sub>A</sub> | NC               |
| <b>N</b> | DQP <sub>B</sub> | NC              | V <sub>DDQ</sub>  | V <sub>SS</sub>   | NC                | NC                | NC               | V <sub>SS</sub> | V <sub>DDQ</sub> | NC              | NC               |
| <b>P</b> | NC/144M          | NC/72M          | A                 | A                 | TDI               | A1                | TDO              | A               | A                | A               | NC/288M          |
| <b>R</b> | MODE             | NC/36M          | A                 | A                 | TMS               | A0                | TCK              | A               | A                | A               | A                |

## Pin Definitions

| Name                                                                           | I/O                            | Description                                                                                                                                                                                                                                                                                                                                                                                                                                                                                                                                                                                                                                                                                                                                            |
|--------------------------------------------------------------------------------|--------------------------------|--------------------------------------------------------------------------------------------------------------------------------------------------------------------------------------------------------------------------------------------------------------------------------------------------------------------------------------------------------------------------------------------------------------------------------------------------------------------------------------------------------------------------------------------------------------------------------------------------------------------------------------------------------------------------------------------------------------------------------------------------------|
| A <sub>0</sub> , A <sub>1</sub> , A                                            | Input-Synchronous              | <b>Address Inputs used to select one of the address locations.</b> Sampled at the rising edge of the CLK. A <sub>[1:0]</sub> are fed to the two-bit burst counter.                                                                                                                                                                                                                                                                                                                                                                                                                                                                                                                                                                                     |
| $\overline{BW}_A$ , $\overline{BW}_B$<br>$\overline{BW}_C$ , $\overline{BW}_D$ | Input-Synchronous              | <b>Byte Write Inputs, active LOW.</b> Qualified with $\overline{WE}$ to conduct Writes to the SRAM. Sampled on the rising edge of CLK.                                                                                                                                                                                                                                                                                                                                                                                                                                                                                                                                                                                                                 |
| $\overline{WE}$                                                                | Input-Synchronous              | <b>Write Enable Input, active LOW.</b> Sampled on the rising edge of CLK if $\overline{CEN}$ is active LOW. This signal must be asserted LOW to initiate a write sequence.                                                                                                                                                                                                                                                                                                                                                                                                                                                                                                                                                                             |
| $\overline{ADV/LD}$                                                            | Input-Synchronous              | <b>Advance/Load Input.</b> Used to advance the on-chip address counter or load a new address. When HIGH (and $\overline{CEN}$ is asserted LOW) the internal burst counter is advanced. When LOW, a new address can be loaded into the device for an access. After being deselected, $\overline{ADV/LD}$ should be driven LOW in order to load a new address.                                                                                                                                                                                                                                                                                                                                                                                           |
| CLK                                                                            | Input-Clock                    | <b>Clock Input.</b> Used to capture all synchronous inputs to the device. CLK is qualified with $\overline{CEN}$ . CLK is only recognized if $\overline{CEN}$ is active LOW.                                                                                                                                                                                                                                                                                                                                                                                                                                                                                                                                                                           |
| CE <sub>1</sub>                                                                | Input-Synchronous              | <b>Chip Enable 1 Input, active LOW.</b> Sampled on the rising edge of CLK. Used in conjunction with CE <sub>2</sub> , and CE <sub>3</sub> to select/deselect the device.                                                                                                                                                                                                                                                                                                                                                                                                                                                                                                                                                                               |
| CE <sub>2</sub>                                                                | Input-Synchronous              | <b>Chip Enable 2 Input, active HIGH.</b> Sampled on the rising edge of CLK. Used in conjunction with CE <sub>1</sub> and CE <sub>3</sub> to select/deselect the device.                                                                                                                                                                                                                                                                                                                                                                                                                                                                                                                                                                                |
| $\overline{CE}_3$                                                              | Input-Synchronous              | <b>Chip Enable 3 Input, active LOW.</b> Sampled on the rising edge of CLK. Used in conjunction with CE <sub>1</sub> and CE <sub>2</sub> to select/deselect the device.                                                                                                                                                                                                                                                                                                                                                                                                                                                                                                                                                                                 |
| $\overline{OE}$                                                                | Input-Asynchronous             | <b>Output Enable, asynchronous input, active LOW.</b> Combined with the synchronous logic block inside the device to control the direction of the I/O pins. When LOW, the I/O pins are allowed to behave as outputs. When deasserted HIGH, I/O pins are tri-stated, and act as input data pins. $\overline{OE}$ is masked during the data portion of a write sequence, during the first clock when emerging from a deselected state, when the device has been deselected.                                                                                                                                                                                                                                                                              |
| $\overline{CEN}$                                                               | Input-Synchronous              | <b>Clock Enable Input, active LOW.</b> When asserted LOW the Clock signal is recognized by the SRAM. When deasserted HIGH the Clock signal is masked. Since deasserting $\overline{CEN}$ does not deselect the device, $\overline{CEN}$ can be used to extend the previous cycle when required.                                                                                                                                                                                                                                                                                                                                                                                                                                                        |
| ZZ                                                                             | Input-Asynchronous             | <b>ZZ "Sleep" Input.</b> This active HIGH input places the device in a non-time critical "sleep" condition with data integrity preserved. For normal operation, this pin has to be LOW or left floating. ZZ pin has an internal pull-down.                                                                                                                                                                                                                                                                                                                                                                                                                                                                                                             |
| DQ <sub>s</sub>                                                                | I/O-Synchronous                | <b>Bidirectional Data I/O lines.</b> As inputs, they feed into an on-chip data register that is triggered by the rising edge of CLK. As outputs, they deliver the data contained in the memory location specified by the addresses presented during the previous clock rise of the Read cycle. The direction of the pins is controlled by $\overline{OE}$ . When $\overline{OE}$ is asserted LOW, the pins behave as outputs. When HIGH, DQ <sub>s</sub> and DQP <sub>x</sub> are placed in a tri-state condition. The outputs are automatically tri-stated during the data portion of a Write sequence, during the first clock when emerging from a deselected state, and when the device is deselected, regardless of the state of $\overline{OE}$ . |
| DQP <sub>x</sub>                                                               | I/O-Synchronous                | <b>Bidirectional Data Parity I/O Lines.</b> Functionally, these signals are identical to DQ <sub>s</sub> . During Write sequences, DQP <sub>x</sub> is controlled by $\overline{BW}_x$ correspondingly.                                                                                                                                                                                                                                                                                                                                                                                                                                                                                                                                                |
| MODE                                                                           | Input Strap Pin                | <b>Mode Input. Selects the burst order of the device.</b> When tied to Gnd selects linear burst sequence. When tied to V <sub>DD</sub> or left floating selects interleaved burst sequence.                                                                                                                                                                                                                                                                                                                                                                                                                                                                                                                                                            |
| V <sub>DD</sub>                                                                | Power Supply                   | <b>Power supply inputs to the core of the device.</b>                                                                                                                                                                                                                                                                                                                                                                                                                                                                                                                                                                                                                                                                                                  |
| V <sub>DDQ</sub>                                                               | I/O Power Supply               | <b>Power supply for the I/O circuitry.</b>                                                                                                                                                                                                                                                                                                                                                                                                                                                                                                                                                                                                                                                                                                             |
| V <sub>SS</sub>                                                                | Ground                         | <b>Ground for the device.</b>                                                                                                                                                                                                                                                                                                                                                                                                                                                                                                                                                                                                                                                                                                                          |
| TDO                                                                            | JTAG serial output Synchronous | <b>Serial data-out to the JTAG circuit.</b> Delivers data on the negative edge of TCK. If the JTAG feature is not being utilized, this pin should be left unconnected. This pin is not available on TQFP packages.                                                                                                                                                                                                                                                                                                                                                                                                                                                                                                                                     |
| TDI                                                                            | JTAG serial input Synchronous  | <b>Serial data-in to the JTAG circuit.</b> Sampled on the rising edge of TCK. If the JTAG feature is not being utilized, this pin can be left floating or connected to V <sub>DD</sub> through a pull up resistor. This pin is not available on TQFP packages.                                                                                                                                                                                                                                                                                                                                                                                                                                                                                         |

## Pin Definitions (continued)

| Name         | I/O                              | Description                                                                                                                                                                                                                  |
|--------------|----------------------------------|------------------------------------------------------------------------------------------------------------------------------------------------------------------------------------------------------------------------------|
| TMS          | JTAG serial input<br>Synchronous | <b>Serial data-In to the JTAG circuit.</b> Sampled on the rising edge of TCK. If the JTAG feature is not being utilized, this pin can be disconnected or connected to $V_{DD}$ . This pin is not available on TQFP packages. |
| TCK          | JTAG<br>Clock                    | <b>Clock input to the JTAG circuitry.</b> If the JTAG feature is not being utilized, this pin must be connected to $V_{SS}$ . This pin is not available on TQFP packages.                                                    |
| NC           | –                                | <b>No Connects.</b> Not internally connected to the die. 18 Mbit, 36 Mbit, 72 Mbit, 144 Mbit, 288 Mbit, 576 Mbit and 1G are address expansion pins and are not internally connected to the die.                              |
| $V_{SS}/DNU$ | Ground/DNU                       | This pin can be connected to Ground or should be left floating.                                                                                                                                                              |

## Functional Overview

The CY7C1355C/CY7C1357C is a synchronous flow-through burst SRAM designed specifically to eliminate wait states during Write-Read transitions. All synchronous inputs pass through input registers controlled by the rising edge of the clock. The clock signal is qualified with the Clock Enable input signal (CEN). If CEN is HIGH, the clock signal is not recognized and all internal states are maintained. All synchronous operations are qualified with CEN. Maximum access delay from the clock rise ( $t_{CDV}$ ) is 6.5 ns (133-MHz device).

Accesses can be initiated by asserting all three Chip Enables ( $\overline{CE}_1$ ,  $\overline{CE}_2$ ,  $\overline{CE}_3$ ) active at the rising edge of the clock. If Clock Enable (CEN) is active LOW and ADV/LD is asserted LOW, the address presented to the device will be latched. The access can either be a Read or Write operation, depending on the status of the Write Enable (WE).  $BW_X$  can be used to conduct Byte Write operations.

Write operations are qualified by the Write Enable ( $\overline{WE}$ ). All writes are simplified with on-chip synchronous self-timed Write circuitry.

Three synchronous Chip Enables ( $\overline{CE}_1$ ,  $\overline{CE}_2$ ,  $\overline{CE}_3$ ) and an asynchronous Output Enable (OE) simplify depth expansion. All operations (Reads, Writes, and Deselects) are pipelined. ADV/LD should be driven LOW once the device has been deselected in order to load a new address for the next operation.

### Single Read Accesses

A read access is initiated when the following conditions are satisfied at clock rise: (1) CEN is asserted LOW, (2)  $\overline{CE}_1$ ,  $\overline{CE}_2$ , and  $\overline{CE}_3$  are ALL asserted active, (3) the Write Enable input signal WE is deasserted HIGH, and 4) ADV/LD is asserted LOW. The address presented to the address inputs is latched into the address register and presented to the memory array and control logic. The control logic determines that a read access is in progress and allows the requested data to propagate to the output buffers. The data is available within 7.5 ns (133-MHz device) provided OE is active LOW. After the first clock of the read access, the output buffers are controlled by OE and the internal control logic. OE must be driven LOW in order for the device to drive out the requested data. On the subsequent clock, another operation (Read/Write/Deselect) can be initiated. When the SRAM is deselected at clock rise by one of the chip enable signals, its output will be tri-stated immediately.

### Burst Read Accesses

The CY7C1355C/CY7C1357C has an on-chip burst counter that allows the user the ability to supply a single address and conduct up to four Reads without reasserting the address inputs. ADV/LD must be driven LOW in order to load a new address into the SRAM, as described in the Single Read Access section above. The sequence of the burst counter is determined by the MODE input signal. A LOW input on MODE selects a linear burst mode, a HIGH selects an interleaved burst sequence. Both burst counters use A0 and A1 in the burst sequence, and will wrap around when incremented sufficiently. A HIGH input on ADV/LD will increment the internal burst counter regardless of the state of chip enable inputs or  $\overline{WE}$ .  $\overline{WE}$  is latched at the beginning of a burst cycle. Therefore, the type of access (Read or Write) is maintained throughout the burst sequence.

### Single Write Accesses

Write access are initiated when the following conditions are satisfied at clock rise: (1) CEN is asserted LOW, (2)  $\overline{CE}_1$ ,  $\overline{CE}_2$ , and  $\overline{CE}_3$  are ALL asserted active, and (3) the Write signal WE is asserted LOW. The address presented to the address bus is loaded into the address register. The write signals are latched into the Control Logic block. The data lines are automatically tri-stated regardless of the state of the OE input signal. This allows the external logic to present the data on DQs and DQP<sub>X</sub>.

On the next clock rise the data presented to DQs and DQP<sub>X</sub> (or a subset for byte write operations, see Truth Table for details) inputs is latched into the device and the write is complete. Additional accesses (Read/Write/Deselect) can be initiated on this cycle.

The data written during the Write operation is controlled by  $BW_X$  signals. The CY7C1355C/CY7C1357C provides byte write capability that is described in the Truth Table. Asserting the Write Enable input (WE) with the selected Byte Write Select input will selectively write to only the desired bytes. Bytes not selected during a byte write operation will remain unaltered. A synchronous self-timed Write mechanism has been provided to simplify the Write operations. Byte Write capability has been included in order to greatly simplify Read/Modify/Write sequences, which can be reduced to simple Byte Write operations.

Because the CY7C1355C/CY7C1357C is a common I/O device, data should not be driven into the device while the outputs are active. The Output Enable (OE) can be deasserted HIGH before presenting data to the DQs and DQP<sub>X</sub> inputs. Doing so will tri-state the output drivers. As a safety

precaution, DQs and DQP<sub>X</sub> are automatically tri-stated during the data portion of a write cycle, regardless of the state of OE.

### Burst Write Accesses

The CY7C1355C/CY7C1357C has an on-chip burst counter that allows the user the ability to supply a single address and conduct up to four Write operations without reasserting the address inputs. ADV/LD must be driven LOW in order to load the initial address, as described in the Single Write Access section above. When ADV/LD is driven HIGH on the subsequent clock rise, the Chip Enables (CE<sub>1</sub>, CE<sub>2</sub>, and CE<sub>3</sub>) and WE inputs are ignored and the burst counter is incremented. The correct BW<sub>X</sub> inputs must be driven in each cycle of the burst write, in order to write the correct bytes of data.

### Sleep Mode

The ZZ input pin is an asynchronous input. Asserting ZZ places the SRAM in a power conservation “sleep” mode. Two clock cycles are required to enter into or exit from this “sleep” mode. While in this mode, data integrity is guaranteed. Accesses pending when entering the “sleep” mode are not considered valid nor is the completion of the operation guaranteed. The device must be deselected prior to entering the “sleep” mode. CE<sub>1</sub>, CE<sub>2</sub>, and CE<sub>3</sub>, must remain inactive for the duration of t<sub>ZZREC</sub> after the ZZ input returns LOW.

### ZZ Mode Electrical Characteristics

| Parameter          | Description                       | Test Conditions             | Min.              | Max.              | Unit |
|--------------------|-----------------------------------|-----------------------------|-------------------|-------------------|------|
| I <sub>DDZZ</sub>  | Sleep mode standby current        | ZZ ≥ V <sub>DD</sub> - 0.2V |                   | 50                | mA   |
| t <sub>ZZS</sub>   | Device operation to ZZ            | ZZ ≥ V <sub>DD</sub> - 0.2V |                   | 2t <sub>CYC</sub> | ns   |
| t <sub>ZZREC</sub> | ZZ recovery time                  | ZZ ≤ 0.2V                   | 2t <sub>CYC</sub> |                   | ns   |
| t <sub>ZZI</sub>   | ZZ active to sleep current        | This parameter is sampled   |                   | 2t <sub>CYC</sub> | ns   |
| t <sub>RZZI</sub>  | ZZ Inactive to exit sleep current | This parameter is sampled   | 0                 |                   | ns   |

### Truth Table<sup>[2, 3, 4, 5, 6, 7, 8]</sup>

| Operation                    | Address Used | CE <sub>1</sub> | CE <sub>2</sub> | CE <sub>3</sub> | ZZ | ADV/LD | WE | BW <sub>X</sub> | OE | CEN | CLK  | DQ           |
|------------------------------|--------------|-----------------|-----------------|-----------------|----|--------|----|-----------------|----|-----|------|--------------|
| Deselect Cycle               | None         | H               | X               | X               | L  | L      | X  | X               | X  | L   | L->H | Tri-State    |
| Deselect Cycle               | None         | X               | X               | H               | L  | L      | X  | X               | X  | L   | L->H | Tri-State    |
| Deselect Cycle               | None         | X               | L               | X               | L  | L      | X  | X               | X  | L   | L->H | Tri-State    |
| Continue Deselect Cycle      | None         | X               | X               | X               | L  | H      | X  | X               | X  | L   | L->H | Tri-State    |
| READ Cycle (Begin Burst)     | External     | L               | H               | L               | L  | L      | H  | X               | L  | L   | L->H | Data Out (Q) |
| READ Cycle (Continue Burst)  | Next         | X               | X               | X               | L  | H      | X  | X               | L  | L   | L->H | Data Out (Q) |
| NOP/DUMMY READ (Begin Burst) | External     | L               | H               | L               | L  | L      | H  | X               | H  | L   | L->H | Tri-State    |
| DUMMY READ (Continue Burst)  | Next         | X               | X               | X               | L  | H      | X  | X               | H  | L   | L->H | Tri-State    |
| WRITE Cycle (Begin Burst)    | External     | L               | H               | L               | L  | L      | L  | L               | X  | L   | L->H | Data In (D)  |
| WRITE Cycle (Continue Burst) | Next         | X               | X               | X               | L  | H      | X  | L               | X  | L   | L->H | Data In (D)  |

#### Notes:

- X = “Don’t Care.” H = Logic HIGH, L = Logic LOW. BW<sub>X</sub> = L signifies at least one Byte Write Select is active, BW<sub>X</sub> = Valid signifies that the desired Byte Write Selects are asserted, see Truth Table for details.
- Write is defined by BW<sub>X</sub>, and WE. See Truth Table for Read/Write.
- When a Write cycle is detected, all I/Os are tri-stated, even during Byte Writes.
- The DQs and DQP<sub>X</sub> pins are controlled by the current cycle and the OE signal. OE is asynchronous and is not sampled with the clock.
- CEN = H, inserts wait states.
- Device will power-up deselected and the I/Os in a tri-state condition, regardless of OE.
- OE is asynchronous and is not sampled with the clock rise. It is masked internally during Write cycles. During a Read cycle DQs and DQP<sub>X</sub> = Tri-state when OE is inactive or when the device is deselected, and DQs and DQP<sub>X</sub> = data when OE is active.

### Interleaved Burst Address Table (MODE = Floating or VDD)

| First Address A1: A0 | Second Address A1: A0 | Third Address A1: A0 | Fourth Address A1: A0 |
|----------------------|-----------------------|----------------------|-----------------------|
| 00                   | 01                    | 10                   | 11                    |
| 01                   | 00                    | 11                   | 10                    |
| 10                   | 11                    | 00                   | 01                    |
| 11                   | 10                    | 01                   | 00                    |

### Linear Burst Address Table (MODE = GND)

| First Address A1: A0 | Second Address A1: A0 | Third Address A1: A0 | Fourth Address A1: A0 |
|----------------------|-----------------------|----------------------|-----------------------|
| 00                   | 01                    | 10                   | 11                    |
| 01                   | 10                    | 11                   | 00                    |
| 10                   | 11                    | 00                   | 01                    |
| 11                   | 00                    | 01                   | 10                    |

**Truth Table**<sup>[2, 3, 4, 5, 6, 7, 8]</sup>

| Operation                     | Address Used | $\overline{CE}_1$ | $CE_2$ | $\overline{CE}_3$ | ZZ | ADV/LD | $\overline{WE}$ | $\overline{BW}_X$ | $\overline{OE}$ | $\overline{CEN}$ | CLK  | DQ        |
|-------------------------------|--------------|-------------------|--------|-------------------|----|--------|-----------------|-------------------|-----------------|------------------|------|-----------|
| NOP/WRITE ABORT (Begin Burst) | None         | L                 | H      | L                 | L  | L      | L               | H                 | X               | L                | L->H | Tri-State |
| WRITE ABORT (Continue Burst)  | Next         | X                 | X      | X                 | L  | H      | X               | H                 | X               | L                | L->H | Tri-State |
| IGNORE CLOCK EDGE (Stall)     | Current      | X                 | X      | X                 | L  | X      | X               | X                 | X               | H                | L->H | –         |
| SLEEP MODE                    | None         | X                 | X      | X                 | H  | X      | X               | X                 | X               | X                | X    | Tri-State |

**Partial Truth Table for Read/Write**<sup>[2, 3, 9]</sup>

| Function (CY7C1355C)                                   | $\overline{WE}$ | $\overline{BW}_A$ | $\overline{BW}_B$ | $\overline{BW}_C$ | $\overline{BW}_D$ |
|--------------------------------------------------------|-----------------|-------------------|-------------------|-------------------|-------------------|
| Read                                                   | H               | X                 | X                 | X                 | X                 |
| Write No bytes written                                 | L               | H                 | H                 | H                 | H                 |
| Write Byte A – (DQ <sub>A</sub> and DQP <sub>A</sub> ) | L               | L                 | H                 | H                 | H                 |
| Write Byte B – (DQ <sub>B</sub> and DQP <sub>B</sub> ) | L               | H                 | L                 | H                 | H                 |
| Write Byte C – (DQ <sub>C</sub> and DQP <sub>C</sub> ) | L               | H                 | H                 | L                 | H                 |
| Write Byte D – (DQ <sub>D</sub> and DQP <sub>D</sub> ) | L               | H                 | H                 | H                 | L                 |
| Write All Bytes                                        | L               | L                 | L                 | L                 | L                 |

**Truth Table for Read/Write**<sup>[2, 3, 9]</sup>

| Function (CY7C1357C)                                   | $\overline{WE}$ | $\overline{BW}_A$ | $\overline{BW}_B$ |
|--------------------------------------------------------|-----------------|-------------------|-------------------|
| Read                                                   | H               | X                 | X                 |
| Write - No bytes written                               | L               | H                 | H                 |
| Write Byte A – (DQ <sub>A</sub> and DQP <sub>A</sub> ) | L               | H                 | H                 |
| Write Byte B – (DQ <sub>B</sub> and DQP <sub>B</sub> ) | L               | H                 | H                 |
| Write All Bytes                                        | L               | L                 | L                 |

**Note:**

9. Table only lists a partial listing of the byte write combinations. Any combination of  $\overline{BW}_X$  is valid. Appropriate write will be done based on which byte write is active.

## IEEE 1149.1 Serial Boundary Scan (JTAG)

The CY7C1355C/CY7C1357C incorporates a serial boundary scan test access port (TAP) in the BGA package only. The TQFP package does not offer this functionality. This part operates in accordance with IEEE Standard 1149.1-1900, but doesn't have the set of functions required for full 1149.1 compliance. These functions from the IEEE specification are excluded because their inclusion places an added delay in the critical speed path of the SRAM. Note the TAP controller functions in a manner that does not conflict with the operation of other devices using 1149.1 fully compliant TAPs. The TAP operates using JEDEC-standard 3.3V or 2.5V I/O logic levels.

The CY7C1355C/CY7C1357C contains a TAP controller, instruction register, boundary scan register, bypass register, and ID register.

### Disabling the JTAG Feature

It is possible to operate the SRAM without using the JTAG feature. To disable the TAP controller, TCK must be tied LOW (Vss) to prevent clocking of the device. TDI and TMS are internally pulled up and may be unconnected. They may alternately be connected to VDD through a pull-up resistor. TDO should be left unconnected. Upon power-up, the device will come up in a reset state which will not interfere with the operation of the device.

### TAP Controller State Diagram

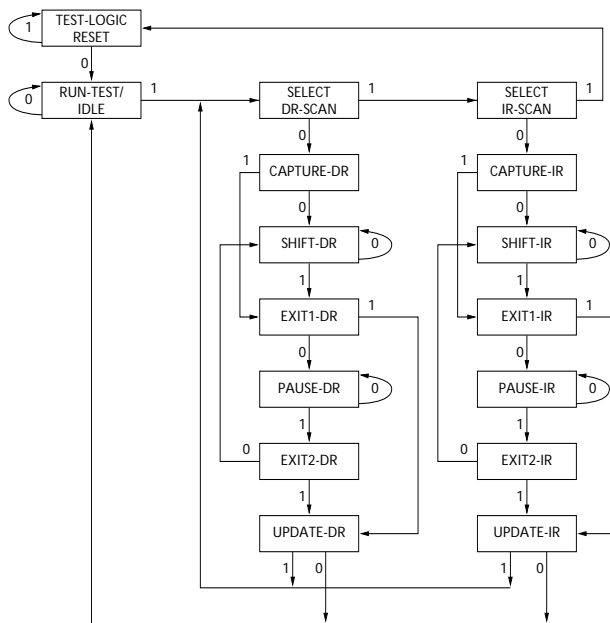

The 0/1 next to each state represents the value of TMS at the rising edge of the TCK.

### Test Access Port (TAP)

#### Test Clock (TCK)

The test clock is used only with the TAP controller. All inputs are captured on the rising edge of TCK. All outputs are driven from the falling edge of TCK.

#### Test MODE SELECT (TMS)

The TMS input is used to give commands to the TAP controller and is sampled on the rising edge of TCK. It is allowable to leave this ball unconnected if the TAP is not used. The ball is pulled up internally, resulting in a logic HIGH level.

#### Test Data-In (TDI)

The TDI ball is used to serially input information into the registers and can be connected to the input of any of the registers. The register between TDI and TDO is chosen by the instruction that is loaded into the TAP instruction register. TDI is internally pulled up and can be unconnected if the TAP is unused in an application. TDI is connected to the most significant bit (MSB) of any register. (See Tap Controller Block Diagram.)

#### Test Data-Out (TDO)

The TDO output ball is used to serially clock data-out from the registers. The output is active depending upon the current state of the TAP state machine. The output changes on the falling edge of TCK. TDO is connected to the least significant bit (LSB) of any register. (See Tap Controller State Diagram.)

### TAP Controller Block Diagram

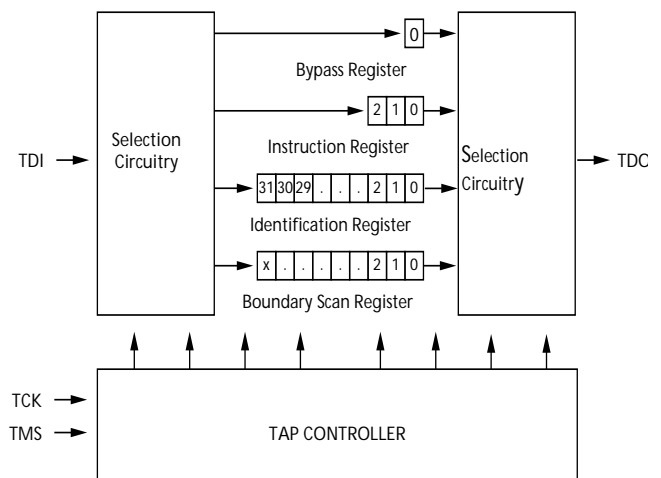

### Performing a TAP Reset

A RESET is performed by forcing TMS HIGH (VDD) for five rising edges of TCK. This RESET does not affect the operation of the SRAM and may be performed while the SRAM is operating.

At power-up, the TAP is reset internally to ensure that TDO comes up in a High-Z state.

### TAP Registers

Registers are connected between the TDI and TDO balls and allow data to be scanned into and out of the SRAM test circuitry. Only one register can be selected at a time through the instruction register. Data is serially loaded into the TDI ball on the rising edge of TCK. Data is output on the TDO ball on the falling edge of TCK.

#### Instruction Register

Three-bit instructions can be serially loaded into the instruction register. This register is loaded when it is placed between the TDI and TDO balls as shown in the Tap Controller Block

Diagram. Upon power-up, the instruction register is loaded with the IDCODE instruction. It is also loaded with the IDCODE instruction if the controller is placed in a reset state as described in the previous section.

When the TAP controller is in the Capture-IR state, the two least significant bits are loaded with a binary “01” pattern to allow for fault isolation of the board-level serial test data path.

#### *Bypass Register*

To save time when serially shifting data through registers, it is sometimes advantageous to skip certain chips. The bypass register is a single-bit register that can be placed between the TDI and TDO balls. This allows data to be shifted through the SRAM with minimal delay. The bypass register is set LOW (Vss) when the BYPASS instruction is executed.

#### *Boundary Scan Register*

The boundary scan register is connected to all the input and bidirectional balls on the SRAM.

The boundary scan register is loaded with the contents of the RAM I/O ring when the TAP controller is in the Capture-DR state and is then placed between the TDI and TDO balls when the controller is moved to the Shift-DR state. The EXTEST, SAMPLE/PRELOAD and SAMPLE Z instructions can be used to capture the contents of the I/O ring.

The Boundary Scan Order tables show the order in which the bits are connected. Each bit corresponds to one of the bumps on the SRAM package. The MSB of the register is connected to TDI, and the LSB is connected to TDO.

#### *Identification (ID) Register*

The ID register is loaded with a vendor-specific, 32-bit code during the Capture-DR state when the IDCODE command is loaded in the instruction register. The IDCODE is hardwired into the SRAM and can be shifted out when the TAP controller is in the Shift-DR state. The ID register has a vendor code and other information described in the Identification Register Definitions table.

### **TAP Instruction Set**

#### *Overview*

Eight different instructions are possible with the three bit instruction register. All combinations are listed in the Instruction Codes table. Three of these instructions are listed as RESERVED and should not be used. The other five instructions are described in detail below.

Instructions are loaded into the TAP controller during the Shift-IR state when the instruction register is placed between TDI and TDO. During this state, instructions are shifted through the instruction register through the TDI and TDO balls. To execute the instruction once it is shifted in, the TAP controller needs to be moved into the Update-IR state.

#### *IDCODE*

The IDCODE instruction causes a vendor-specific, 32-bit code to be loaded into the instruction register. It also places the instruction register between the TDI and TDO balls and allows the IDCODE to be shifted out of the device when the TAP controller enters the Shift-DR state. The IDCODE instruction is loaded into the instruction register upon power-up or whenever the TAP controller is given a test logic reset state.

#### *SAMPLE Z*

The SAMPLE Z instruction causes the boundary scan register to be connected between the TDI and TDO pins when the TAP controller is in a Shift-DR state. The SAMPLE Z command puts the output bus into a High-Z state until the next command is given during the “Update IR” state.

#### *SAMPLE/PRELOAD*

SAMPLE/PRELOAD is a 1149.1 mandatory instruction. When the SAMPLE/PRELOAD instructions are loaded into the instruction register and the TAP controller is in the Capture-DR state, a snapshot of data on the inputs and output pins is captured in the boundary scan register.

The user must be aware that the TAP controller clock can only operate at a frequency up to 20 MHz, while the SRAM clock operates more than an order of magnitude faster. Because there is a large difference in the clock frequencies, it is possible that during the Capture-DR state, an input or output will undergo a transition. The TAP may then try to capture a signal while in transition (metastable state). This will not harm the device, but there is no guarantee as to the value that will be captured. Repeatable results may not be possible.

To guarantee that the boundary scan register will capture the correct value of a signal, the SRAM signal must be stabilized long enough to meet the TAP controller's capture set-up plus hold times ( $t_{CS}$  and  $t_{CH}$ ). The SRAM clock input might not be captured correctly if there is no way in a design to stop (or slow) the clock during a SAMPLE/PRELOAD instruction. If this is an issue, it is still possible to capture all other signals and simply ignore the value of the CK and CK# captured in the boundary scan register.

Once the data is captured, it is possible to shift out the data by putting the TAP into the Shift-DR state. This places the boundary scan register between the TDI and TDO pins.

PRELOAD allows an initial data pattern to be placed at the latched parallel outputs of the boundary scan register cells prior to the selection of another boundary scan test operation.

The shifting of data for the SAMPLE and PRELOAD phases can occur concurrently when required—that is, while data captured is shifted out, the preloaded data can be shifted in.

#### *BYPASS*

When the BYPASS instruction is loaded in the instruction register and the TAP is placed in a Shift-DR state, the bypass register is placed between the TDI and TDO pins. The advantage of the BYPASS instruction is that it shortens the boundary scan path when multiple devices are connected together on a board.

#### *EXTEST*

The EXTEST instruction enables the preloaded data to be driven out through the system output pins. This instruction also selects the boundary scan register to be connected for serial access between the TDI and TDO in the shift-DR controller state.

#### *Reserved*

These instructions are not implemented but are reserved for future use. Do not use these instructions.

## TAP Timing

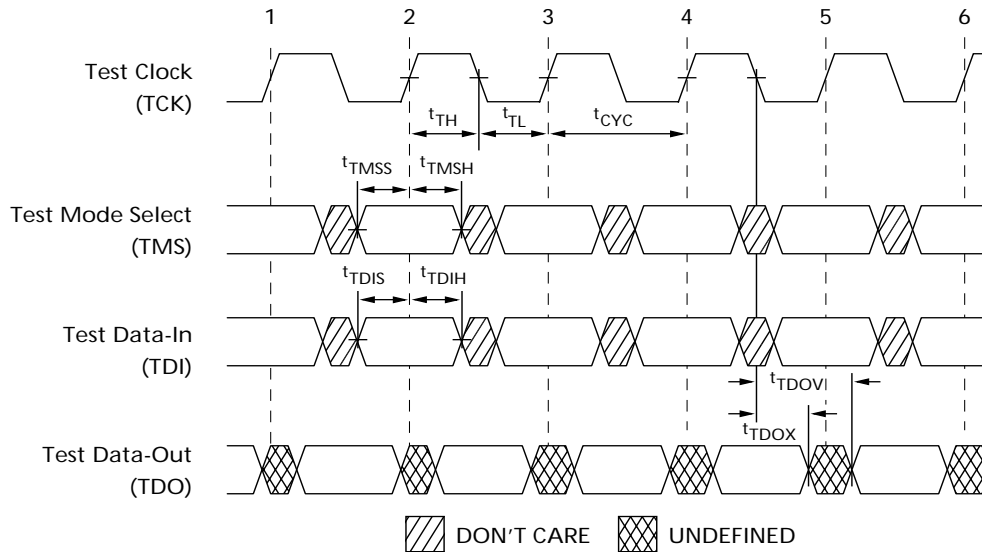

## TAP AC Switching Characteristics Over the Operating Range<sup>[10, 11]</sup>

| Parameter           | Description                   | Min. | Max. | Unit |
|---------------------|-------------------------------|------|------|------|
| <b>Clock</b>        |                               |      |      |      |
| $t_{TCYC}$          | TCK Clock Cycle Time          | 50   |      | ns   |
| $t_{TF}$            | TCK Clock Frequency           |      | 20   | MHz  |
| $t_{TH}$            | TCK Clock HIGH Time           | 20   |      | ns   |
| $t_{TL}$            | TCK Clock LOW Time            | 20   |      | ns   |
| <b>Output Times</b> |                               |      |      |      |
| $t_{TDOV}$          | TCK Clock LOW to TDO Valid    |      | 10   | ns   |
| $t_{TDOX}$          | TCK Clock LOW to TDO Invalid  | 0    |      | ns   |
| <b>Set-up Times</b> |                               |      |      |      |
| $t_{TMSS}$          | TMS Set-Up to TCK Clock Rise  | 5    |      | ns   |
| $t_{TDIS}$          | TDI Set-Up to TCK Clock Rise  | 5    |      | ns   |
| $t_{CS}$            | Capture Set-Up to TCK Rise    | 5    |      | ns   |
| <b>Hold Times</b>   |                               |      |      |      |
| $t_{TMSH}$          | TMS Hold after TCK Clock Rise | 5    |      | ns   |
| $t_{TDIH}$          | TDI Hold after Clock Rise     | 5    |      | ns   |
| $t_{CH}$            | Capture Hold after Clock Rise | 5    |      | ns   |

**Notes:**

10.  $t_{CS}$  and  $t_{CH}$  refer to the set-up and hold time requirements of latching data from the boundary scan register.  
 11. Test conditions are specified using the load in TAP AC Test Conditions.  $t_R/t_F = 1$  ns.

### 3.3V TAP AC Test Conditions

Input pulse levels .....  $V_{SS}$  to 3.3V  
 Input rise and fall times ..... 1 ns  
 Input timing reference levels ..... 1.5V  
 Output reference levels ..... 1.5V  
 Test load termination supply voltage ..... 1.5V

### 2.5V TAP AC Test Conditions

Input pulse levels .....  $V_{SS}$  to 2.5V  
 Input rise and fall time ..... 1 ns  
 Input timing reference levels ..... 1.25V  
 Output reference levels ..... 1.25V  
 Test load termination supply voltage ..... 1.25V

### 3.3V TAP AC Output Load Equivalent

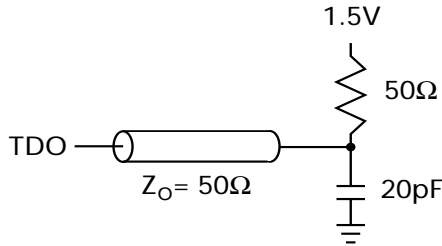

### 2.5V TAP AC Output Load Equivalent

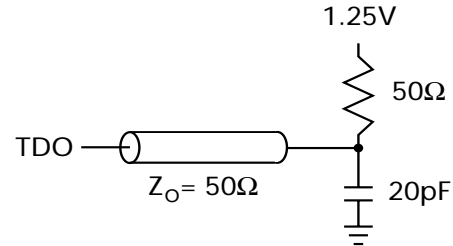

**TAP DC Electrical Characteristics And Operating Conditions** ( $0^{\circ}\text{C} < T_A < +70^{\circ}\text{C}$ ;  $V_{DD} = 3.3\text{V} \pm 0.165\text{V}$  unless otherwise noted)<sup>[12]</sup>

| Parameter | Description         | Conditions                                                                                                 | Min.                    | Max. | Unit                |
|-----------|---------------------|------------------------------------------------------------------------------------------------------------|-------------------------|------|---------------------|
| $V_{OH1}$ | Output HIGH Voltage | $I_{OH} = -4.0\text{ mA}$ , $V_{DDQ} = 3.3\text{V}$<br>$I_{OH} = -1.0\text{ mA}$ , $V_{DDQ} = 2.5\text{V}$ | 2.4                     |      | V                   |
|           |                     |                                                                                                            | 2.0                     |      | V                   |
| $V_{OH2}$ | Output HIGH Voltage | $I_{OH} = -100\text{ }\mu\text{A}$                                                                         | $V_{DDQ} = 3.3\text{V}$ | 2.9  | V                   |
|           |                     |                                                                                                            | $V_{DDQ} = 2.5\text{V}$ | 2.1  | V                   |
| $V_{OL1}$ | Output LOW Voltage  | $I_{OL} = 8.0\text{ mA}$                                                                                   | $V_{DDQ} = 3.3\text{V}$ | 0.4  | V                   |
|           |                     |                                                                                                            | $V_{DDQ} = 2.5\text{V}$ | 0.4  | V                   |
| $V_{OL2}$ | Output LOW Voltage  | $I_{OL} = 100\text{ }\mu\text{A}$                                                                          | $V_{DDQ} = 3.3\text{V}$ | 0.2  | V                   |
|           |                     |                                                                                                            | $V_{DDQ} = 2.5\text{V}$ | 0.2  | V                   |
| $V_{IH}$  | Input HIGH Voltage  |                                                                                                            | $V_{DDQ} = 3.3\text{V}$ | 2.0  | $V_{DD} + 0.3$<br>V |
|           |                     |                                                                                                            | $V_{DDQ} = 2.5\text{V}$ | 1.7  | $V_{DD} + 0.3$<br>V |
| $V_{IL}$  | Input LOW Voltage   |                                                                                                            | $V_{DDQ} = 3.3\text{V}$ | -0.5 | 0.7<br>V            |
|           |                     |                                                                                                            | $V_{DDQ} = 2.5\text{V}$ | -0.3 | 0.7<br>V            |
| $I_X$     | Input Load Current  | $\text{GND} \leq V_{IN} \leq V_{DDQ}$                                                                      | -5                      | 5    | $\mu\text{A}$       |

### Identification Register Definitions

| Instruction Field                  | CY7C1355C<br>(256Kx36) | CY7C1357C<br>(512Kx18) | Description                                 |
|------------------------------------|------------------------|------------------------|---------------------------------------------|
| Revision Number (31:29)            | 010                    | 010                    | Describes the version number                |
| Device Depth (28:24)               | 01010                  | 01010                  | Reserved for Internal Use                   |
| Device Width (23:18)               | 001001                 | 001001                 | Defines memory type and architecture        |
| Cypress Device ID (17:12)          | 100110                 | 010110                 | Defines width and density                   |
| Cypress JEDEC ID Code (11:1)       | 00000110100            | 00000110100            | Allows unique identification of SRAM vendor |
| ID Register Presence Indicator (0) | 1                      | 1                      | Indicates the presence of an ID register    |

**Note:**  
 12. All voltages referenced to  $V_{SS}$  (GND).

**Scan Register Sizes**

| Register Name                               | Bit Size (x36) | Bit Size (x18) |
|---------------------------------------------|----------------|----------------|
| Instruction                                 | 3              | 3              |
| Bypass                                      | 1              | 1              |
| ID                                          | 32             | 32             |
| Boundary Scan Order (119-ball BGA package)  | 69             | 69             |
| Boundary Scan Order (165-ball FBGA package) | 69             | 69             |

**Identification Codes**

| Instruction    | Code | Description                                                                                                                                                                                                           |
|----------------|------|-----------------------------------------------------------------------------------------------------------------------------------------------------------------------------------------------------------------------|
| EXTEST         | 000  | Captures I/O ring contents. Places the boundary scan register between TDI and TDO. Forces all SRAM outputs to High-Z state. This instruction is not 1149.1 compliant.                                                 |
| IDCODE         | 001  | Loads the ID register with the vendor ID code and places the register between TDI and TDO. This operation does not affect SRAM operations.                                                                            |
| SAMPLE Z       | 010  | Captures I/O ring contents. Places the boundary scan register between TDI and TDO. Forces all SRAM output drivers to a High-Z state.                                                                                  |
| RESERVED       | 011  | Do Not Use: This instruction is reserved for future use.                                                                                                                                                              |
| SAMPLE/PRELOAD | 100  | Captures I/O ring contents. Places the boundary scan register between TDI and TDO. Does not affect SRAM operation. This instruction does not implement 1149.1 preload function and is therefore not 1149.1 compliant. |
| RESERVED       | 101  | Do Not Use: This instruction is reserved for future use.                                                                                                                                                              |
| RESERVED       | 110  | Do Not Use: This instruction is reserved for future use.                                                                                                                                                              |
| BYPASS         | 111  | Places the bypass register between TDI and TDO. This operation does not affect SRAM operations.                                                                                                                       |

**119-ball BGA Boundary Scan Order**

| CY7C1355C (256K x 36) |         |                  |      |          |                   |
|-----------------------|---------|------------------|------|----------|-------------------|
| Bit#                  | ball ID | Signal Name      | Bit# | ball ID  | Signal Name       |
| 1                     | K4      | CLK              | 37   | R6       | A                 |
| 2                     | H4      | $\overline{WE}$  | 38   | T5       | A                 |
| 3                     | M4      | $\overline{CEN}$ | 39   | T3       | A                 |
| 4                     | F4      | $\overline{OE}$  | 40   | R2       | A                 |
| 5                     | B4      | ADV/LD           | 41   | R3       | MODE              |
| 6                     | G4      | A                | 42   | P2       | DQP <sub>D</sub>  |
| 7                     | C3      | A                | 43   | P1       | DQ <sub>D</sub>   |
| 8                     | B3      | A                | 44   | L2       | DQ <sub>D</sub>   |
| 9                     | D6      | DQP <sub>B</sub> | 45   | K1       | DQ <sub>D</sub>   |
| 10                    | H7      | DQ <sub>B</sub>  | 46   | N2       | DQ <sub>D</sub>   |
| 11                    | G6      | DQ <sub>B</sub>  | 47   | N1       | DQ <sub>D</sub>   |
| 12                    | E6      | DQ <sub>B</sub>  | 48   | M2       | DQ <sub>D</sub>   |
| 13                    | D7      | DQ <sub>B</sub>  | 49   | L1       | DQ <sub>D</sub>   |
| 14                    | E7      | DQ <sub>B</sub>  | 50   | K2       | DQ <sub>D</sub>   |
| 15                    | F6      | DQ <sub>B</sub>  | 51   | Internal | Internal          |
| 16                    | G7      | DQ <sub>B</sub>  | 52   | H1       | DQ <sub>C</sub>   |
| 17                    | H6      | DQ <sub>B</sub>  | 53   | G2       | DQ <sub>C</sub>   |
| 18                    | T7      | ZZ               | 54   | E2       | DQ <sub>C</sub>   |
| 19                    | K7      | DQ <sub>A</sub>  | 55   | D1       | DQ <sub>C</sub>   |
| 20                    | L6      | DQ <sub>A</sub>  | 56   | H2       | DQ <sub>C</sub>   |
| 21                    | N6      | DQ <sub>A</sub>  | 57   | G1       | DQ <sub>C</sub>   |
| 22                    | P7      | DQ <sub>A</sub>  | 58   | F2       | DQ <sub>C</sub>   |
| 23                    | N7      | DQ <sub>A</sub>  | 59   | E1       | DQ <sub>C</sub>   |
| 24                    | M6      | DQ <sub>A</sub>  | 60   | D2       | DQP <sub>C</sub>  |
| 25                    | L7      | DQ <sub>A</sub>  | 61   | C2       | A                 |
| 26                    | K6      | DQ <sub>A</sub>  | 62   | A2       | A                 |
| 27                    | P6      | DQP <sub>A</sub> | 63   | E4       | $\overline{CE}_1$ |
| 28                    | T4      | A                | 64   | B2       | $\overline{CE}_2$ |
| 29                    | A3      | A                | 65   | L3       | $\overline{BW}_D$ |
| 30                    | C5      | A                | 66   | G3       | $\overline{BW}_C$ |
| 31                    | B5      | A                | 67   | G5       | $\overline{BWB}$  |
| 32                    | A5      | A                | 68   | L5       | $\overline{BW}_A$ |
| 33                    | C6      | A                | 69   | B6       | $\overline{CE}_3$ |
| 34                    | A6      | A                |      |          |                   |
| 35                    | P4      | A0               |      |          |                   |
| 36                    | N4      | A1               |      |          |                   |

| CY7C1357C (512K x 18) |          |                  |      |          |                   |
|-----------------------|----------|------------------|------|----------|-------------------|
| Bit#                  | ball Id  | Signal Name      | Bit# | ball Id  | Signal Name       |
| 1                     | K4       | CLK              | 37   | R6       | A                 |
| 2                     | H4       | $\overline{WE}$  | 38   | T5       | A                 |
| 3                     | M4       | $\overline{CEN}$ | 39   | T3       | A                 |
| 4                     | F4       | $\overline{OE}$  | 40   | R2       | A                 |
| 5                     | B4       | ADV/LD           | 41   | R3       | MODE              |
| 6                     | G4       | A                | 42   | Internal | Internal          |
| 7                     | C3       | A                | 43   | Internal | Internal          |
| 8                     | B3       | A                | 44   | Internal | Internal          |
| 9                     | T2       | A                | 45   | Internal | Internal          |
| 10                    | Internal | Internal         | 46   | P2       | DQP <sub>B</sub>  |
| 11                    | Internal | Internal         | 47   | N1       | DQ <sub>B</sub>   |
| 12                    | Internal | Internal         | 48   | M2       | DQ <sub>B</sub>   |
| 13                    | D6       | DQP <sub>A</sub> | 49   | L1       | DQ <sub>B</sub>   |
| 14                    | E7       | DQ <sub>A</sub>  | 50   | K2       | DQ <sub>B</sub>   |
| 15                    | F6       | DQ <sub>A</sub>  | 51   | Internal | Internal          |
| 16                    | G7       | DQ <sub>A</sub>  | 52   | H1       | DQ <sub>B</sub>   |
| 17                    | H6       | DQ <sub>A</sub>  | 53   | G2       | DQ <sub>B</sub>   |
| 18                    | T7       | ZZ               | 54   | E2       | DQ <sub>B</sub>   |
| 19                    | K7       | DQ <sub>A</sub>  | 55   | D1       | DQ <sub>B</sub>   |
| 20                    | L6       | DQ <sub>A</sub>  | 56   | Internal | Internal          |
| 21                    | N6       | DQ <sub>A</sub>  | 57   | Internal | Internal          |
| 22                    | P7       | DQ <sub>A</sub>  | 58   | Internal | Internal          |
| 23                    | Internal | Internal         | 59   | Internal | Internal          |
| 24                    | Internal | Internal         | 60   | Internal | Internal          |
| 25                    | Internal | Internal         | 61   | C2       | A                 |
| 26                    | Internal | Internal         | 62   | A2       | A                 |
| 27                    | Internal | Internal         | 63   | E4       | $\overline{CE}_1$ |
| 28                    | T6       | A                | 64   | B2       | $\overline{CE}_2$ |
| 29                    | A3       | A                | 65   | Internal | Internal          |
| 30                    | C5       | A                | 66   | G3       | $\overline{BW}_B$ |
| 31                    | B5       | A                | 67   | Internal | Internal          |
| 32                    | A5       | A                | 68   | L5       | $\overline{BW}_A$ |
| 33                    | C6       | A                | 69   | B6       | $\overline{CE}_3$ |
| 34                    | A6       | A                |      |          |                   |
| 35                    | P4       | A0               |      |          |                   |
| 36                    | N4       | A1               |      |          |                   |

**165-ball FBGA Boundary Scan Order**

| CY7C1355C (256K x 36) |         |                  |      |          |                   |
|-----------------------|---------|------------------|------|----------|-------------------|
| Bit#                  | ball ID | Signal Name      | Bit# | ball ID  | Signal Name       |
| 1                     | B6      | CLK              | 37   | R4       | A                 |
| 2                     | B7      | $\overline{WE}$  | 38   | P4       | A                 |
| 3                     | A7      | $\overline{CEN}$ | 39   | R3       | A                 |
| 4                     | B8      | $\overline{OE}$  | 40   | P3       | A                 |
| 5                     | A8      | ADV/LD           | 41   | R1       | MODE              |
| 6                     | A9      | A                | 42   | N1       | DQP <sub>D</sub>  |
| 7                     | B10     | A                | 43   | L2       | DQ <sub>D</sub>   |
| 8                     | A10     | A                | 44   | K2       | DQ <sub>D</sub>   |
| 9                     | C11     | DQP <sub>B</sub> | 45   | J2       | DQ <sub>D</sub>   |
| 10                    | E10     | DQ <sub>B</sub>  | 46   | M2       | DQ <sub>D</sub>   |
| 11                    | F10     | DQ <sub>B</sub>  | 47   | M1       | DQ <sub>D</sub>   |
| 12                    | G10     | DQ <sub>B</sub>  | 48   | L1       | DQ <sub>D</sub>   |
| 13                    | D10     | DQ <sub>B</sub>  | 49   | K1       | DQ <sub>D</sub>   |
| 14                    | D11     | DQ <sub>B</sub>  | 50   | J1       | DQ <sub>D</sub>   |
| 15                    | E11     | DQ <sub>B</sub>  | 51   | Internal | Internal          |
| 16                    | F11     | DQ <sub>B</sub>  | 52   | G2       | DQ <sub>C</sub>   |
| 17                    | G11     | DQ <sub>B</sub>  | 53   | F2       | DQ <sub>C</sub>   |
| 18                    | H11     | ZZ               | 54   | E2       | DQ <sub>C</sub>   |
| 19                    | J10     | DQ <sub>A</sub>  | 55   | D2       | DQ <sub>C</sub>   |
| 20                    | K10     | DQ <sub>A</sub>  | 56   | G1       | DQ <sub>C</sub>   |
| 21                    | L10     | DQ <sub>A</sub>  | 57   | F1       | DQ <sub>C</sub>   |
| 22                    | M10     | DQ <sub>A</sub>  | 58   | E1       | DQ <sub>C</sub>   |
| 23                    | J11     | DQ <sub>A</sub>  | 59   | D1       | DQ <sub>C</sub>   |
| 24                    | K11     | DQ <sub>A</sub>  | 60   | C1       | DQP <sub>C</sub>  |
| 25                    | L11     | DQ <sub>A</sub>  | 61   | B2       | A                 |
| 26                    | M11     | DQ <sub>A</sub>  | 62   | A2       | A                 |
| 27                    | N11     | DQP <sub>A</sub> | 63   | A3       | CE <sub>1</sub>   |
| 28                    | R11     | A                | 64   | B3       | CE <sub>2</sub>   |
| 29                    | R10     | A                | 65   | B4       | BW <sub>D</sub>   |
| 30                    | P10     | A                | 66   | A4       | $\overline{BW}_C$ |
| 31                    | R9      | A                | 67   | A5       | $\overline{BW}_B$ |
| 32                    | P9      | A                | 68   | B5       | $\overline{BW}_A$ |
| 33                    | R8      | A                | 69   | A6       | $\overline{CE}_3$ |
| 34                    | P8      | A                |      |          |                   |
| 35                    | R6      | A0               |      |          |                   |
| 36                    | P6      | A1               |      |          |                   |

| CY7C1357C (512K x 18) |          |                  |      |          |                   |
|-----------------------|----------|------------------|------|----------|-------------------|
| Bit#                  | ball ID  | Signal Name      | Bit# | ball ID  | Signal Name       |
| 1                     | B6       | CLK              | 37   | R4       | A                 |
| 2                     | B7       | $\overline{WE}$  | 38   | P4       | A                 |
| 3                     | A7       | $\overline{CEN}$ | 39   | R3       | A                 |
| 4                     | B8       | $\overline{OE}$  | 40   | P3       | A                 |
| 5                     | A8       | ADV/LD           | 41   | R1       | MODE              |
| 6                     | A9       | A                | 42   | Internal | Internal          |
| 7                     | B10      | A                | 43   | Internal | Internal          |
| 8                     | A10      | A                | 44   | Internal | Internal          |
| 9                     | A11      | A                | 45   | Internal | Internal          |
| 10                    | Internal | Internal         | 46   | N1       | DQP <sub>B</sub>  |
| 11                    | Internal | Internal         | 47   | M1       | DQ <sub>B</sub>   |
| 12                    | Internal | Internal         | 48   | L1       | DQ <sub>B</sub>   |
| 13                    | C11      | DQP <sub>A</sub> | 49   | K1       | DQ <sub>B</sub>   |
| 14                    | D11      | DQ <sub>A</sub>  | 50   | J1       | DQ <sub>B</sub>   |
| 15                    | E11      | DQ <sub>A</sub>  | 51   | Internal | Internal          |
| 16                    | F11      | DQ <sub>A</sub>  | 52   | G2       | DQ <sub>B</sub>   |
| 17                    | G11      | DQ <sub>A</sub>  | 53   | F2       | DQ <sub>B</sub>   |
| 18                    | H11      | ZZ               | 54   | E2       | DQ <sub>B</sub>   |
| 19                    | J10      | DQ <sub>A</sub>  | 55   | D2       | DQ <sub>B</sub>   |
| 20                    | K10      | DQ <sub>A</sub>  | 56   | Internal | Internal          |
| 21                    | L10      | DQ <sub>A</sub>  | 57   | Internal | Internal          |
| 22                    | M10      | DQ <sub>A</sub>  | 58   | Internal | Internal          |
| 23                    | Internal | Internal         | 59   | Internal | Internal          |
| 24                    | Internal | Internal         | 60   | Internal | Internal          |
| 25                    | Internal | Internal         | 61   | B2       | A                 |
| 26                    | Internal | Internal         | 62   | A2       | A                 |
| 27                    | Internal | Internal         | 63   | A3       | CE <sub>1</sub>   |
| 28                    | R11      | A                | 64   | B3       | CE <sub>2</sub>   |
| 29                    | R10      | A                | 65   | Internal | Internal          |
| 30                    | P10      | A                | 66   | Internal | Internal          |
| 31                    | R9       | A                | 67   | A4       | $\overline{BW}_B$ |
| 32                    | P9       | A                | 68   | B5       | $\overline{BW}_A$ |
| 33                    | R8       | A                | 69   | A6       | $\overline{CE}_3$ |
| 34                    | P8       | A                |      |          |                   |
| 35                    | R6       | A0               |      |          |                   |
| 36                    | P6       | A1               |      |          |                   |

**Maximum Ratings**

(Above which the useful life may be impaired. For user guidelines, not tested.)

- Storage Temperature ..... -65°C to +150°C
- Ambient Temperature with Power Applied..... -55°C to +125°C
- Supply Voltage on V<sub>DD</sub> Relative to GND..... -0.5V to +4.6V
- Supply Voltage on V<sub>DDQ</sub> Relative to GND ..... -0.5V to +V<sub>DD</sub>
- DC Voltage Applied to Outputs in Tri-State..... -0.5V to V<sub>DDQ</sub> + 0.5V

- DC Input Voltage ..... -0.5V to V<sub>DD</sub> + 0.5V
- Current into Outputs (LOW)..... 20 mA
- Static Discharge Voltage..... > 2001V (per MIL-STD-883, Method 3015)
- Latch-up Current..... > 200 mA.

**Operating Range**

| Range      | Ambient Temperature | V <sub>DD</sub> | V <sub>DDQ</sub>             |
|------------|---------------------|-----------------|------------------------------|
| Commercial | 0°C to +70°C        | 3.3V – 5%/+10%  | 2.5V – 5% to V <sub>DD</sub> |
| Industrial | -40°C to +85°C      |                 |                              |

**Electrical Characteristics** Over the Operating Range<sup>[13, 14]</sup>

| Parameter               | Description                                 | Test Conditions                                                                                                                                            | Min.                  | Max.                   | Unit |
|-------------------------|---------------------------------------------|------------------------------------------------------------------------------------------------------------------------------------------------------------|-----------------------|------------------------|------|
| V <sub>DD</sub>         | Power Supply Voltage                        |                                                                                                                                                            | 3.135                 | 3.6                    | V    |
| V <sub>DDQ</sub>        | I/O Supply Voltage                          | for 3.3V I/O                                                                                                                                               | 3.135                 | V <sub>DD</sub>        | V    |
|                         |                                             | for 2.5V I/O                                                                                                                                               | 2.375                 | 2.625                  |      |
| V <sub>OH</sub>         | Output HIGH Voltage                         | for 3.3V I/O, I <sub>OH</sub> = -4.0 mA                                                                                                                    | 2.4                   |                        | V    |
|                         |                                             | for 2.5V I/O, I <sub>OH</sub> = -1.0 mA                                                                                                                    | 2.0                   |                        | V    |
| V <sub>OL</sub>         | Output LOW Voltage                          | for 3.3V I/O, I <sub>OL</sub> = 8.0 mA                                                                                                                     |                       | 0.4                    | V    |
|                         |                                             | for 2.5V I/O, I <sub>OL</sub> = 1.0 mA                                                                                                                     |                       | 0.4                    | V    |
| V <sub>IH</sub>         | Input HIGH Voltage <sup>[13]</sup>          | for 3.3V I/O                                                                                                                                               | 2.0                   | V <sub>DD</sub> + 0.3V | V    |
|                         |                                             | for 2.5V I/O                                                                                                                                               | 1.7                   | V <sub>DD</sub> + 0.3V | V    |
| V <sub>IL</sub>         | Input LOW Voltage <sup>[13]</sup>           | for 3.3V I/O                                                                                                                                               | -0.3                  | 0.8                    | V    |
|                         |                                             | for 2.5V I/O                                                                                                                                               | -0.3                  | 0.7                    | V    |
| I <sub>X</sub>          | Input Leakage Current except ZZ and MODE    | GND ≤ V <sub>I</sub> ≤ V <sub>DDQ</sub>                                                                                                                    | -5                    | 5                      | μA   |
|                         | Input Current of MODE                       | Input = V <sub>SS</sub>                                                                                                                                    | -30                   |                        | μA   |
|                         |                                             | Input = V <sub>DD</sub>                                                                                                                                    |                       | 5                      | μA   |
|                         | Input Current of ZZ                         | Input = V <sub>SS</sub>                                                                                                                                    | -5                    |                        | μA   |
| Input = V <sub>DD</sub> |                                             |                                                                                                                                                            | 30                    | μA                     |      |
| I <sub>OZ</sub>         | Output Leakage Current                      | GND ≤ V <sub>I</sub> ≤ V <sub>DDQ</sub> , Output Disabled                                                                                                  | -5                    | 5                      | μA   |
| I <sub>DD</sub>         | V <sub>DD</sub> Operating Supply Current    | V <sub>DD</sub> = Max., I <sub>OUT</sub> = 0 mA, f = f <sub>MAX</sub> = 1/t <sub>CYC</sub>                                                                 | 7.5-ns cycle, 133 MHz | 250                    | mA   |
|                         |                                             |                                                                                                                                                            | 10-ns cycle, 100 MHz  | 180                    | mA   |
| I <sub>SB1</sub>        | Automatic CE Power-down Current—TTL Inputs  | V <sub>DD</sub> = Max, Device Deselected, V <sub>IN</sub> ≥ V <sub>IH</sub> or V <sub>IN</sub> ≤ V <sub>IL</sub> , f = f <sub>MAX</sub> , inputs switching |                       | 110                    | mA   |
| I <sub>SB2</sub>        | Automatic CE Power-down Current—CMOS Inputs | V <sub>DD</sub> = Max, Device Deselected, V <sub>IN</sub> ≤ 0.3V or V <sub>IN</sub> ≥ V <sub>DD</sub> - 0.3V, f = 0, inputs static                         |                       | 40                     | mA   |
| I <sub>SB3</sub>        | Automatic CE Power-down Current—CMOS Inputs | V <sub>DD</sub> = Max, Device Deselected, or V <sub>IN</sub> ≤ 0.3V or V <sub>IN</sub> ≥ V <sub>DDQ</sub> - 0.3V, f = f <sub>MAX</sub> , inputs switching  |                       | 100                    | mA   |
| I <sub>SB4</sub>        | Automatic CE Power-down Current—TTL Inputs  | V <sub>DD</sub> = Max, Device Deselected, V <sub>IN</sub> ≥ V <sub>IH</sub> or V <sub>IN</sub> ≤ V <sub>IL</sub> , f = 0, inputs static                    |                       | 40                     | mA   |

**Notes:**

- 13. Overshoot: V<sub>IH</sub>(AC) < V<sub>DD</sub> +1.5V (Pulse width less than t<sub>CYC</sub>/2), undershoot: V<sub>IL</sub>(AC) > -2V (Pulse width less than t<sub>CYC</sub>/2).
- 14. T<sub>Power-up</sub>: Assumes a linear ramp from 0V to V<sub>DD</sub>(min.) within 200 ms. During this time V<sub>IH</sub> < V<sub>DD</sub> and V<sub>DDQ</sub> ≤ V<sub>DD</sub>.

**Capacitance<sup>[15]</sup>**

| Parameter | Description              | Test Conditions                                                                                        | 100 TQFP Max. | 119 BGA Max. | 165 FBGA Max. | Unit |
|-----------|--------------------------|--------------------------------------------------------------------------------------------------------|---------------|--------------|---------------|------|
| $C_{IN}$  | Input Capacitance        | $T_A = 25^\circ\text{C}$ , $f = 1\text{ MHz}$ ,<br>$V_{DD} = 3.3\text{V}$ ,<br>$V_{DDQ} = 2.5\text{V}$ | 5             | 5            | 5             | pF   |
| $C_{CLK}$ | Clock Input Capacitance  |                                                                                                        | 5             | 5            | 5             | pF   |
| $C_{I/O}$ | Input/Output Capacitance |                                                                                                        | 5             | 7            | 7             | pF   |

**Thermal Resistance<sup>[15]</sup>**

| Parameter     | Description                              | Test Conditions                                                                                              | 100 TQFP Package | 119 BGA Package | 165 FBGA Package | Unit               |
|---------------|------------------------------------------|--------------------------------------------------------------------------------------------------------------|------------------|-----------------|------------------|--------------------|
| $\Theta_{JA}$ | Thermal Resistance (Junction to Ambient) | Test conditions follow standard test methods and procedures for measuring thermal impedance, per EIA/JESD51. | 29.41            | 34.1            | 16.8             | $^\circ\text{C/W}$ |
| $\Theta_{JC}$ | Thermal Resistance (Junction to Case)    |                                                                                                              | 6.31             | 14.0            | 3.0              | $^\circ\text{C/W}$ |

**AC Test Loads and Waveforms**

**3.3V I/O Test Load**

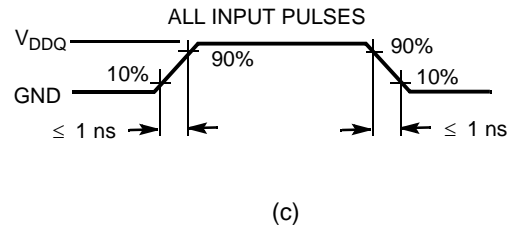
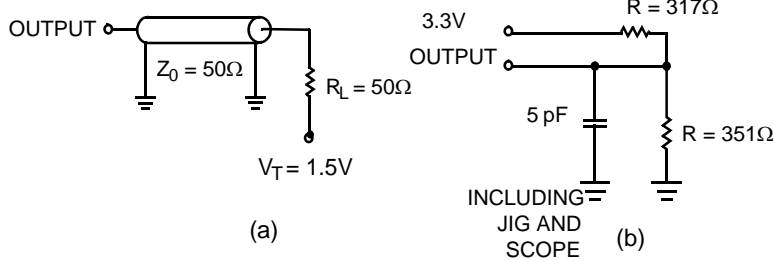

**2.5V I/O Test Load**

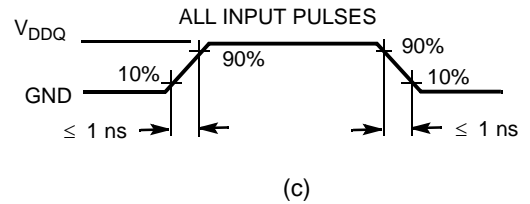
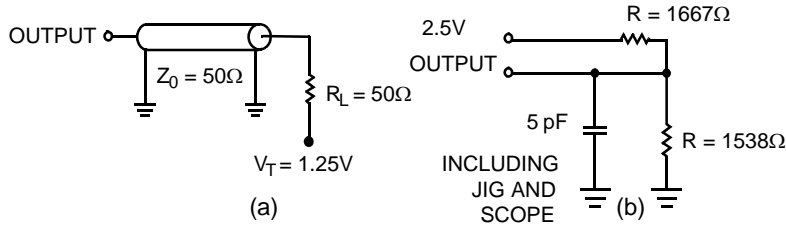

**Note:**  
15. Tested initially and after any design or process change that may affect these parameters

**Switching Characteristics** Over the Operating Range [16, 17]

| Parameter                            | Description                                                   | -133 |      | -100 |      | Unit |
|--------------------------------------|---------------------------------------------------------------|------|------|------|------|------|
|                                      |                                                               | Min. | Max. | Min. | Max. |      |
| t <sub>POWER</sub>                   | V <sub>DD</sub> (Typical) to the First Access <sup>[18]</sup> | 1    |      | 1    |      | ms   |
| <b>Clock</b>                         |                                                               |      |      |      |      |      |
| t <sub>CYC</sub>                     | Clock Cycle Time                                              | 7.5  |      | 10   |      | ns   |
| t <sub>CH</sub>                      | Clock HIGH                                                    | 3.0  |      | 4.0  |      | ns   |
| t <sub>CL</sub>                      | Clock LOW                                                     | 3.0  |      | 4.0  |      | ns   |
| <b>Output Times</b>                  |                                                               |      |      |      |      |      |
| t <sub>CDV</sub>                     | Data Output Valid after CLK Rise                              |      | 6.5  |      | 7.5  | ns   |
| t <sub>DOH</sub>                     | Data Output Hold after CLK Rise                               | 2.0  |      | 2.0  |      | ns   |
| t <sub>CLZ</sub>                     | Clock to Low-Z <sup>[19, 20, 21]</sup>                        | 0    |      | 0    |      | ns   |
| t <sub>CHZ</sub>                     | Clock to High-Z <sup>[19, 20, 21]</sup>                       |      | 3.5  |      | 3.5  | ns   |
| t <sub>OE<math>\bar{V}</math></sub>  | $\overline{OE}$ LOW to Output Valid                           |      | 3.5  |      | 3.5  | ns   |
| t <sub>OE<math>\bar{LZ}</math></sub> | $\overline{OE}$ LOW to Output Low-Z <sup>[19, 20, 21]</sup>   | 0    |      | 0    |      | ns   |
| t <sub>OE<math>\bar{HZ}</math></sub> | $\overline{OE}$ HIGH to Output High-Z <sup>[19, 20, 21]</sup> |      | 3.5  |      | 3.5  | ns   |
| <b>Set-up Times</b>                  |                                                               |      |      |      |      |      |
| t <sub>AS</sub>                      | Address Set-up before CLK Rise                                | 1.5  |      | 1.5  |      | ns   |
| t <sub>ALS</sub>                     | ADV/LD Set-up before CLK Rise                                 | 1.5  |      | 1.5  |      | ns   |
| t <sub>WES</sub>                     | $\overline{WE}$ , $\overline{BW}_X$ Set-up before CLK Rise    | 1.5  |      | 1.5  |      | ns   |
| t <sub>CENS</sub>                    | $\overline{CEN}$ Set-up before CLK Rise                       | 1.5  |      | 1.5  |      | ns   |
| t <sub>DS</sub>                      | Data Input Set-up before CLK Rise                             | 1.5  |      | 1.5  |      | ns   |
| t <sub>CES</sub>                     | Chip Enable Set-Up before CLK Rise                            | 1.5  |      | 1.5  |      | ns   |
| <b>Hold Times</b>                    |                                                               |      |      |      |      |      |
| t <sub>AH</sub>                      | Address Hold after CLK Rise                                   | 0.5  |      | 0.5  |      | ns   |
| t <sub>ALH</sub>                     | ADV/LD Hold after CLK Rise                                    | 0.5  |      | 0.5  |      | ns   |
| t <sub>WEH</sub>                     | $\overline{WE}$ , $\overline{BW}_X$ Hold after CLK Rise       | 0.5  |      | 0.5  |      | ns   |
| t <sub>CENH</sub>                    | $\overline{CEN}$ Hold after CLK Rise                          | 0.5  |      | 0.5  |      | ns   |
| t <sub>DH</sub>                      | Data Input Hold after CLK Rise                                | 0.5  |      | 0.5  |      | ns   |
| t <sub>CEH</sub>                     | Chip Enable Hold after CLK Rise                               | 0.5  |      | 0.5  |      | ns   |

**Notes:**

16. Timing reference level is 1.5V when V<sub>DDQ</sub> = 3.3V and is 1.25V when V<sub>DDQ</sub> = 2.5V.

17. Test conditions shown in (a) of AC Test Loads unless otherwise noted.

18. This part has a voltage regulator internally; t<sub>POWER</sub> is the time that the power needs to be supplied above V<sub>DD</sub>(minimum) initially, before a Read or Write operation can be initiated.

19. t<sub>CHZ</sub>, t<sub>CLZ</sub>, t<sub>OE $\bar{LZ}$</sub> , and t<sub>OE $\bar{HZ}$</sub>  are specified with AC test conditions shown in part (b) of AC Test Loads. Transition is measured  $\pm$  200 mV from steady-state voltage.

20. At any given voltage and temperature, t<sub>OE $\bar{HZ}$</sub>  is less than t<sub>OE $\bar{LZ}$</sub>  and t<sub>CHZ</sub> is less than t<sub>CLZ</sub> to eliminate bus contention between SRAMs when sharing the same data bus. These specifications do not imply a bus contention condition, but reflect parameters guaranteed over worst case user conditions. Device is designed to achieve High-Z prior to Low-Z under the same system conditions.

21. This parameter is sampled and not 100% tested.

### Switching Waveforms

Read/Write Waveforms<sup>[22, 23, 24]</sup>

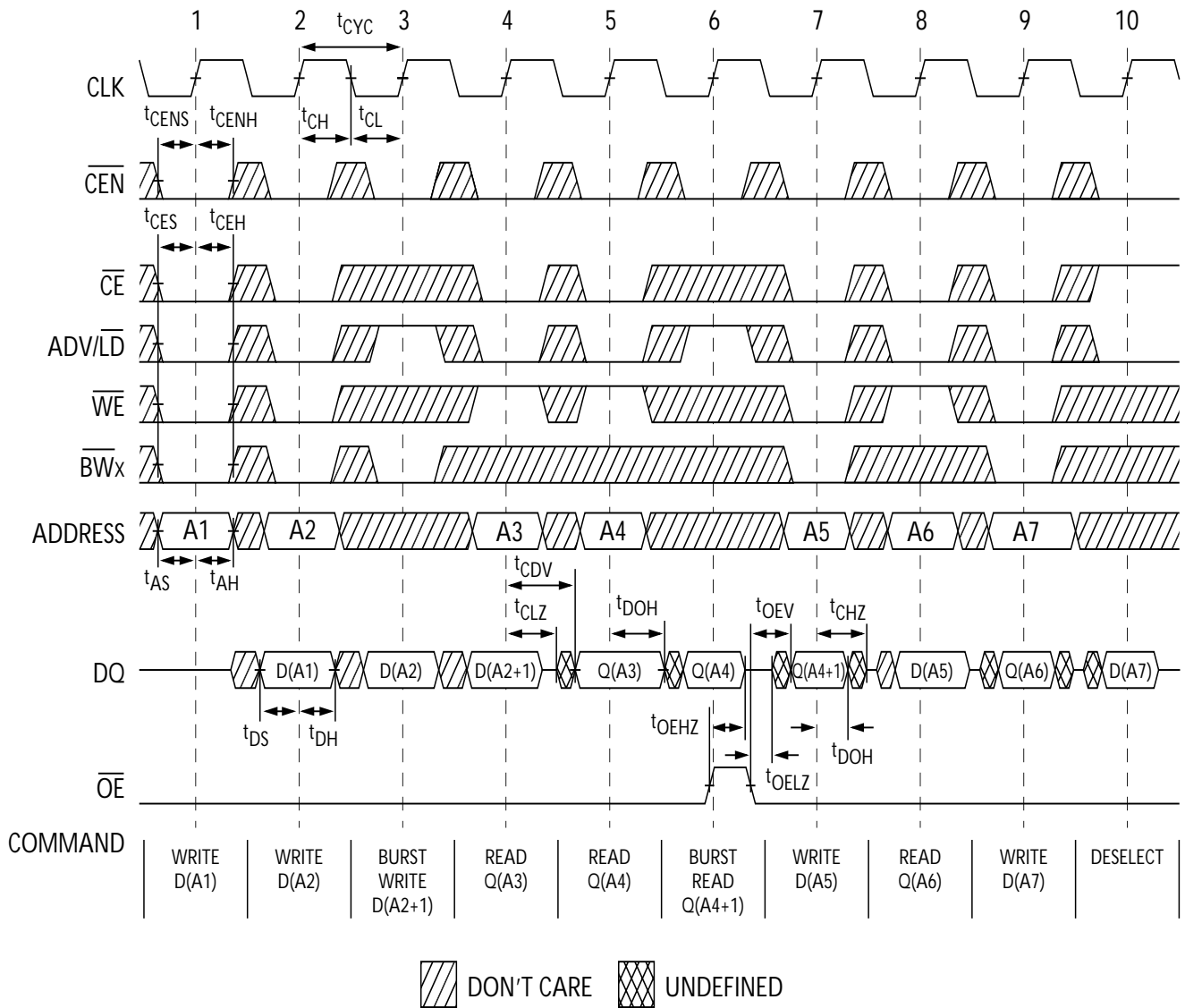

**Notes:**

22. For this waveform ZZ is tied LOW.

23. When  $\overline{CE}$  is LOW,  $\overline{CE}_1$  is LOW,  $\overline{CE}_2$  is HIGH and  $\overline{CE}_3$  is LOW. When  $\overline{CE}$  is HIGH,  $\overline{CE}_1$  is HIGH or  $\overline{CE}_2$  is LOW or  $\overline{CE}_3$  is HIGH.

24. Order of the Burst sequence is determined by the status of the MODE (0 = Linear, 1 = Interleaved). Burst operations are optional.



**Switching Waveforms** (continued)  
**ZZ Mode Timing**<sup>[26, 27]</sup>

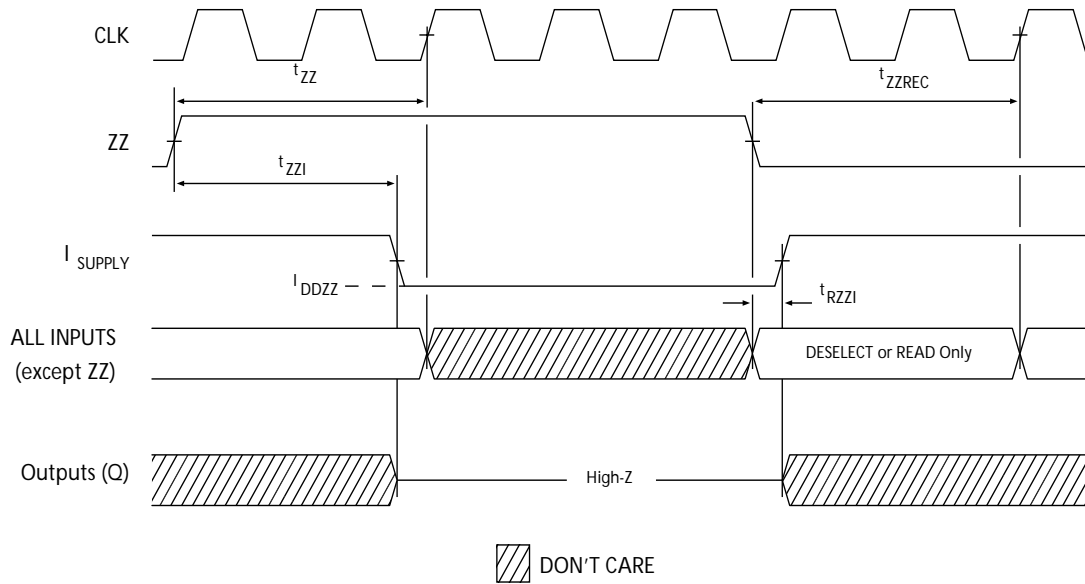

- Notes:**  
 26. Device must be deselected when entering ZZ mode. See truth table for all possible signal conditions to deselect the device.  
 27. DQs are in high-Z when exiting ZZ sleep mode.

**Ordering Information**

Not all of the speed, package and temperature ranges are available. Please contact your local sales representative or visit [www.cypress.com](http://www.cypress.com) for actual products offered.

| Speed (MHz)       | Ordering Code     | Package Diagram                                                  | Part and Package Type                                            | Operating Range |            |
|-------------------|-------------------|------------------------------------------------------------------|------------------------------------------------------------------|-----------------|------------|
| 133               | CY7C1355C-133AXC  | 51-85050                                                         | 100-Pin Thin Quad Flat Pack (14 x 20 x 1.4 mm) Lead-Free         | Commercial      |            |
|                   | CY7C1357C-133AXC  |                                                                  |                                                                  |                 |            |
|                   | CY7C1355C-133BGC  | 51-85115                                                         | 119-ball Ball Grid Array (14 x 22 x 2.4 mm)                      |                 |            |
|                   | CY7C1357C-133BGC  |                                                                  |                                                                  |                 |            |
|                   | CY7C1355C-133BGXC | 51-85115                                                         | 119-ball Ball Grid Array (14 x 22 x 2.4 mm) Lead-Free            |                 |            |
|                   | CY7C1357C-133BGXC |                                                                  |                                                                  |                 |            |
|                   | CY7C1355C-133BZC  | 51-85180                                                         | 165-ball Fine-Pitch Ball Grid Array (13 x 15 x 1.4 mm)           |                 |            |
|                   | CY7C1357C-133BZC  |                                                                  |                                                                  |                 |            |
|                   | CY7C1355C-133BZXC | 51-85180                                                         | 165-ball Fine-Pitch Ball Grid Array (13 x 15 x 1.4 mm) Lead-Free |                 |            |
|                   | CY7C1357C-133BZXC |                                                                  |                                                                  |                 |            |
|                   | CY7C1355C-133AXI  | 51-85050                                                         | 100-Pin Thin Quad Flat Pack (14 x 20 x 1.4 mm) Lead-Free         |                 | Industrial |
|                   | CY7C1357C-133AXI  |                                                                  |                                                                  |                 |            |
|                   | CY7C1355C-133BGI  | 51-85115                                                         | 119-ball Ball Grid Array (14 x 22 x 2.4 mm)                      |                 |            |
|                   | CY7C1357C-133BGI  |                                                                  |                                                                  |                 |            |
|                   | CY7C1355C-133BGXI | 51-85115                                                         | 119-ball Ball Grid Array (14 x 22 x 2.4 mm) Lead-Free            |                 |            |
|                   | CY7C1357C-133BGXI |                                                                  |                                                                  |                 |            |
| CY7C1355C-133BZI  | 51-85180          | 165-ball Fine-Pitch Ball Grid Array (13 x 15 x 1.4 mm)           |                                                                  |                 |            |
| CY7C1357C-133BZI  |                   |                                                                  |                                                                  |                 |            |
| CY7C1355C-133BZXI | 51-85180          | 165-ball Fine-Pitch Ball Grid Array (13 x 15 x 1.4 mm) Lead-Free |                                                                  |                 |            |
| CY7C1357C-133BZXI |                   |                                                                  |                                                                  |                 |            |
| 100               | CY7C1355C-100AXC  | 51-85050                                                         | 100-Pin Thin Quad Flat Pack (14 x 20 x 1.4 mm) Lead-Free         | Commercial      |            |
|                   | CY7C1357C-100AXC  |                                                                  |                                                                  |                 |            |
|                   | CY7C1355C-100BGC  | 51-85115                                                         | 119-ball Ball Grid Array (14 x 22 x 2.4 mm)                      |                 |            |
|                   | CY7C1357C-100BGC  |                                                                  |                                                                  |                 |            |
|                   | CY7C1355C-100BGXC | 51-85115                                                         | 119-ball Ball Grid Array (14 x 22 x 2.4 mm) Lead-Free            |                 |            |
|                   | CY7C1357C-100BGXC |                                                                  |                                                                  |                 |            |
|                   | CY7C1355C-100BZC  | 51-85180                                                         | 165-ball Fine-Pitch Ball Grid Array (13 x 15 x 1.4 mm)           |                 |            |
|                   | CY7C1357C-100BZC  |                                                                  |                                                                  |                 |            |
|                   | CY7C1355C-100BZXC | 51-85180                                                         | 165-ball Fine-Pitch Ball Grid Array (13 x 15 x 1.4 mm) Lead-Free |                 |            |
|                   | CY7C1357C-100BZXC |                                                                  |                                                                  |                 |            |
|                   | CY7C1355C-100AXI  | 51-85050                                                         | 100-Pin Thin Quad Flat Pack (14 x 20 x 1.4 mm) Lead-Free         |                 | Industrial |
|                   | CY7C1357C-100AXI  |                                                                  |                                                                  |                 |            |
|                   | CY7C1355C-100BGI  | 51-85115                                                         | 119-ball Ball Grid Array (14 x 22 x 2.4 mm)                      |                 |            |
|                   | CY7C1357C-100BGI  |                                                                  |                                                                  |                 |            |
|                   | CY7C1355C-100BGXI | 51-85115                                                         | 119-ball Ball Grid Array (14 x 22 x 2.4 mm) Lead-Free            |                 |            |
|                   | CY7C1357C-100BGXI |                                                                  |                                                                  |                 |            |
| CY7C1355C-100BZI  | 51-85180          | 165-ball Fine-Pitch Ball Grid Array (13 x 15 x 1.4 mm)           |                                                                  |                 |            |
| CY7C1357C-100BZI  |                   |                                                                  |                                                                  |                 |            |
| CY7C1355C-100BZXI | 51-85180          | 165-ball Fine-Pitch Ball Grid Array (13 x 15 x 1.4 mm) Lead-Free |                                                                  |                 |            |
| CY7C1357C-100BZXI |                   |                                                                  |                                                                  |                 |            |

Package Diagrams

100-Pin Thin Plastic Quad Flatpack (14 x 20 x 1.4 mm) (51-85050)

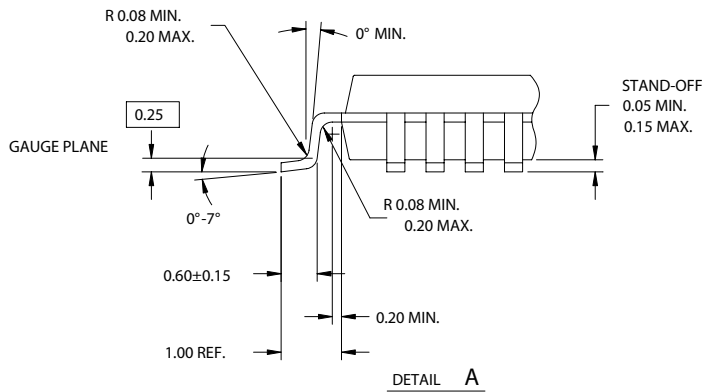
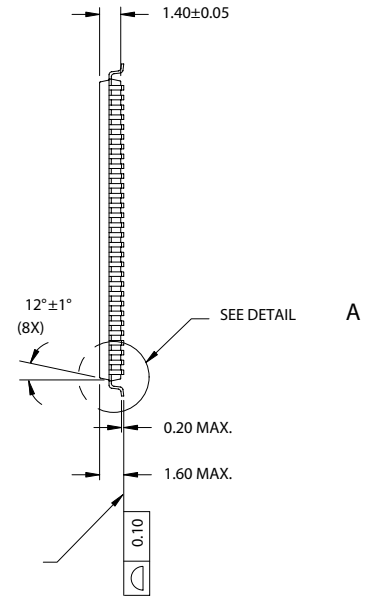
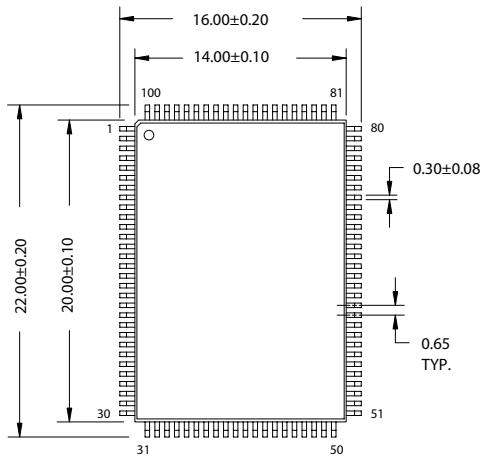

NOTE:

1. JEDEC STD REF MS-026
2. BODY LENGTH DIMENSION DOES NOT INCLUDE MOLD PROTRUSION/END FLASH  
MOLD PROTRUSION/END FLASH SHALL NOT EXCEED 0.0098 in (0.25 mm) PER SIDE  
BODY LENGTH DIMENSIONS ARE MAX PLASTIC BODY SIZE INCLUDING MOLD MISMATCH
3. DIMENSIONS IN MILLIMETERS

51-85050-\*B

**Package Diagrams** (continued)

**119-Ball BGA (14 x 22 x 2.4 mm) (51-85115)**

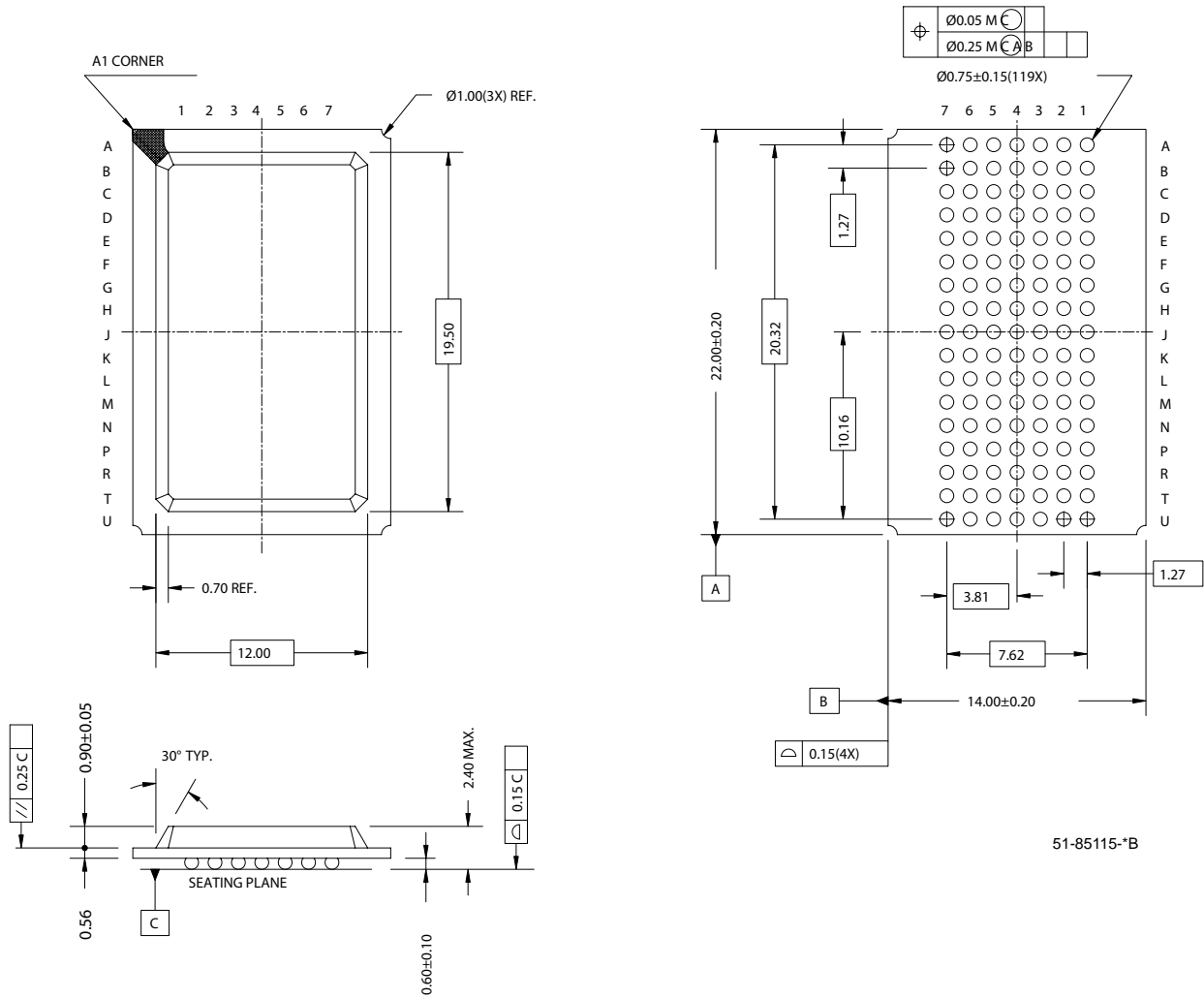

**Package Diagrams** (continued)

**165-Ball FBGA (13 x 15 x 1.4 mm) (51-85180)**

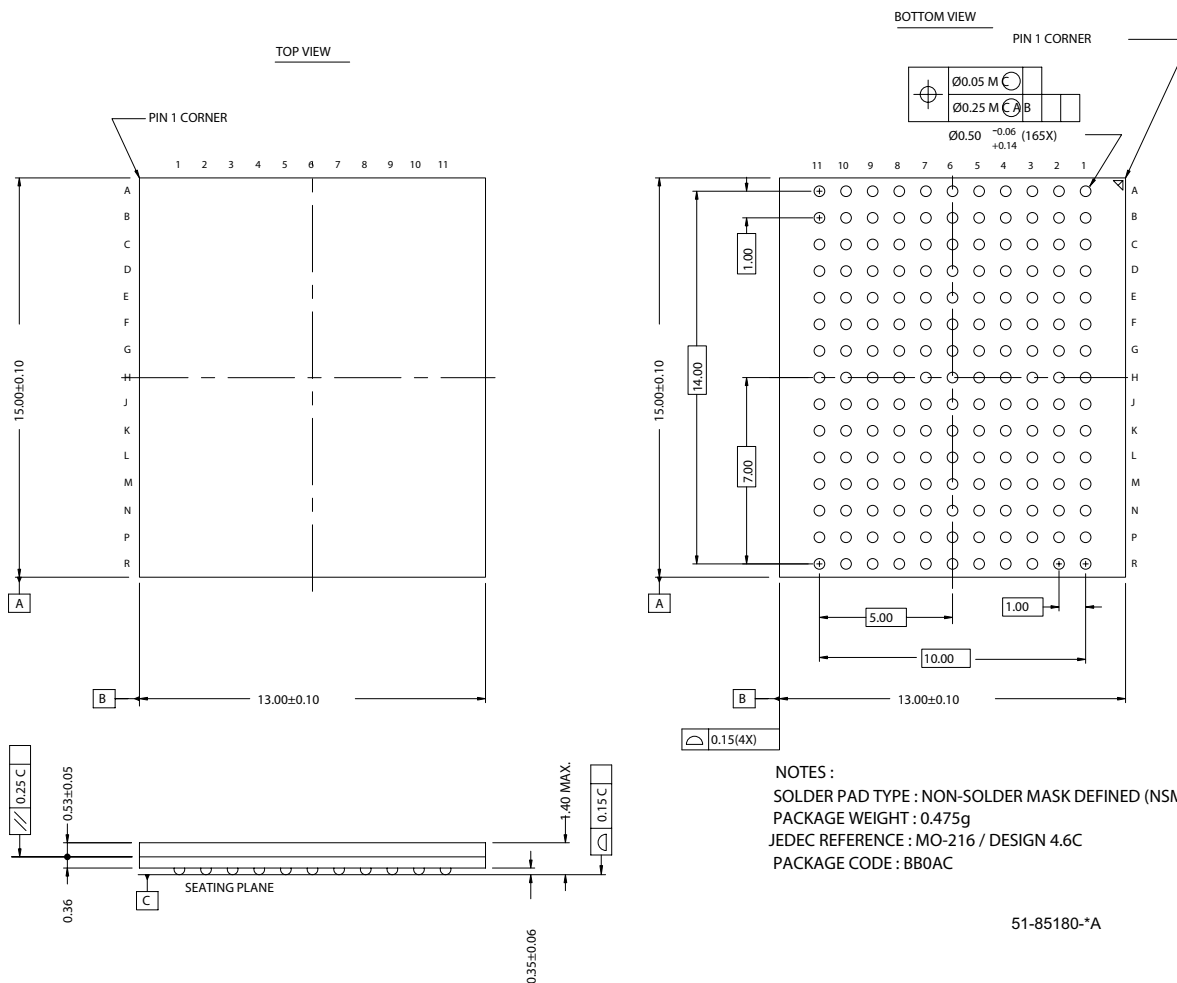

NoBL and No Bus Latency are trademarks of Cypress Semiconductor Corporation. ZBT is a trademark of Integrated Device Technology, Inc. All product and company names mentioned in this document are the trademarks of their respective holders

**Document History Page**

**Document Title: CY7C1355C/CY7C1357C 9-Mbit (256K x 36/512K x 18) Flow-Through SRAM with NoBL™ Architecture**  
**Document Number: 38-05539**

| REV. | ECN NO. | Issue Date | Orig. of Change | Description of Change                                                                                                                                                                                                                                                                                                                                                                                                                                                                                                                                                                                                                                                                                                                                                                                                                                                                                                                                                                                                                                                                                                                                                                                                                                                                                                                                      |
|------|---------|------------|-----------------|------------------------------------------------------------------------------------------------------------------------------------------------------------------------------------------------------------------------------------------------------------------------------------------------------------------------------------------------------------------------------------------------------------------------------------------------------------------------------------------------------------------------------------------------------------------------------------------------------------------------------------------------------------------------------------------------------------------------------------------------------------------------------------------------------------------------------------------------------------------------------------------------------------------------------------------------------------------------------------------------------------------------------------------------------------------------------------------------------------------------------------------------------------------------------------------------------------------------------------------------------------------------------------------------------------------------------------------------------------|
| **   | 242032  | See ECN    | RKF             | New data sheet                                                                                                                                                                                                                                                                                                                                                                                                                                                                                                                                                                                                                                                                                                                                                                                                                                                                                                                                                                                                                                                                                                                                                                                                                                                                                                                                             |
| *A   | 332059  | See ECN    | PCI             | <p>Changed Boundary Scan Order to match the B rev of these devices</p> <p>Removed description on Extest Output Bus Tri-state</p> <p>Removed 117 MHz Speed Bin</p> <p>Changed I<sub>DDZ</sub> from 35 mA to 50 mA on Pg # 9</p> <p>Changed I<sub>SB1</sub> and I<sub>SB3</sub> from 40 mA to 110 and 100 mA respectively</p> <p>Address expansion pins/balls in the pinouts for all packages are modified as per JEDEC standard</p> <p>Modified V<sub>OL</sub>, V<sub>OH</sub> test conditions</p> <p>Corrected I<sub>SB4</sub> Test Condition from (V<sub>IN</sub> ≥ V<sub>DD</sub> - 0.3V or V<sub>IN</sub> ≤ 0.3V) to (V<sub>IN</sub> ≥ V<sub>IH</sub> or V<sub>IN</sub> ≤ V<sub>IL</sub>) in the Electrical Characteristic Table on Pg #18</p> <p>Changed <math>\theta_{JA}</math> and <math>\theta_{Jc}</math> for TQFP Package from 25 and 9 °C/W to 29.41 and 6.13 °C/W respectively</p> <p>Changed <math>\theta_{JA}</math> and <math>\theta_{Jc}</math> for BGA Package from 25 and 6 °C/W to 34.1 and 14.0 °C/W respectively</p> <p>Changed <math>\theta_{JA}</math> and <math>\theta_{Jc}</math> for FBGA Package from 27 and 6 °C/W to 16.8 and 3.0 °C/W respectively</p> <p>Added lead-free information for 100-pin TQFP, 119 BGA and 165 FBGA Packages</p> <p>Updated Ordering Information Table</p> <p>Changed from Preliminary to Final</p> |
| *B   | 351895  | See ECN    | PCI             | <p>Changed I<sub>SB2</sub> from 30 to 40 mA</p> <p>Updated Ordering Information Table</p>                                                                                                                                                                                                                                                                                                                                                                                                                                                                                                                                                                                                                                                                                                                                                                                                                                                                                                                                                                                                                                                                                                                                                                                                                                                                  |
| *C   | 377095  | See ECN    | PCI             | Modified test condition in note# 14 from V <sub>IH</sub> ≤ V <sub>DD</sub> to V <sub>IH</sub> < V <sub>DD</sub>                                                                                                                                                                                                                                                                                                                                                                                                                                                                                                                                                                                                                                                                                                                                                                                                                                                                                                                                                                                                                                                                                                                                                                                                                                            |
| *D   | 408298  | See ECN    | RXU             | <p>Changed address of Cypress Semiconductor Corporation on Page# 1 from "3901 North First Street" to "198 Champion Court"</p> <p>Modified "Input Load" to "Input Leakage Current except ZZ and MODE" in the Electrical Characteristics Table</p> <p>Changed three-state to tri-state</p> <p>Replaced Package Name column with Package Diagram in the Ordering Information table</p> <p>Updated Ordering Information Table</p>                                                                                                                                                                                                                                                                                                                                                                                                                                                                                                                                                                                                                                                                                                                                                                                                                                                                                                                              |
| *E   | 501793  | See ECN    | VKN             | <p>Added the Maximum Rating for Supply Voltage on V<sub>DDQ</sub> Relative to GND</p> <p>Changed t<sub>TH</sub>, t<sub>TL</sub> from 25 ns to 20 ns and t<sub>TDOV</sub> from 5 ns to 10 ns in TAP AC Switching Characteristics table.</p> <p>Updated the Ordering Information table.</p>                                                                                                                                                                                                                                                                                                                                                                                                                                                                                                                                                                                                                                                                                                                                                                                                                                                                                                                                                                                                                                                                  |

## Looking for pricing, stock, or lifecycle information?

Click below to explore more details on WIN SOURCE:

 [View CY7C1357C-100AXCT on WIN SOURCE](#)

 [Cypress Semiconductor Corp](#) Information

## Optimize Your Supply Chain with WIN SOURCE Solutions

-  Global Sourcing Solution
-  Obsolete Management
-  Cost Control Management
-  Shortage Management
-  Alternative Solution
-  Excess Inventory Management