



**THE DATASHEET OF
CY7C1351G-100AXC**



4-Mbit (128K × 36) Flow-Through SRAM with NoBL™ Architecture

Features

- Can support up to 133 MHz bus operations with zero wait states
 - Data is transferred on every clock
- Pin compatible and functionally equivalent to ZBT™ devices
- Internally self-timed output buffer control to eliminate the need to use OE
- Registered inputs for flow-through operation
- Byte write capability
- 128K × 36 common I/O architecture
- 2.5 V/3.3 V I/O power supply (V_{DDQ})
- Fast clock-to-output times
 - 6.5 ns (for 133 MHz device)
- Clock enable ($\overline{\text{CEN}}$) pin to suspend operation
- Synchronous self-timed writes
- Asynchronous output enable
- Available in Pb-free 100-pin TQFP package
- Burst capability – linear or interleaved burst order
- Low standby power

Functional Description

The CY7C1351G is a 3.3 V, 128K × 36 synchronous flow-through burst SRAM designed specifically to support unlimited true back-to-back read/write operations without the insertion of wait states. The CY7C1351G is equipped with the advanced No Bus Latency™ (NoBL™) logic required to enable consecutive Read/Write operations with data being transferred on every clock cycle. This feature dramatically improves the throughput of data through the SRAM, especially in systems that require frequent write-read transitions.

All synchronous inputs pass through input registers controlled by the rising edge of the clock. The clock input is qualified by the clock enable ($\overline{\text{CEN}}$) signal, which when deasserted suspends operation and extends the previous clock cycle. Maximum access delay from the clock rise is 6.5 ns (133-MHz device).

Write operations are controlled by the four byte write select ($\text{BW}_{[A:D]}$) and a write enable ($\overline{\text{WE}}$) input. All writes are conducted with on-chip synchronous self-timed write circuitry.

Three synchronous chip enables ($\overline{\text{CE}}_1, \overline{\text{CE}}_2, \overline{\text{CE}}_3$) and an asynchronous output enable ($\overline{\text{OE}}$) provide for easy bank selection and output tristate control. In order to avoid bus contention, the output drivers are synchronously tristated during the data portion of a write sequence.

For a complete list of related documentation, click [here](#).

Selection Guide

Description	133 MHz	100 MHz	Unit
Maximum access time	6.5	8.0	ns
Maximum operating current	225	205	mA
Maximum CMOS standby current	40	40	mA

Errata: For information on silicon errata, see "Errata" on page 19. Details include trigger conditions, devices affected, and proposed workaround.

Logic Block Diagram

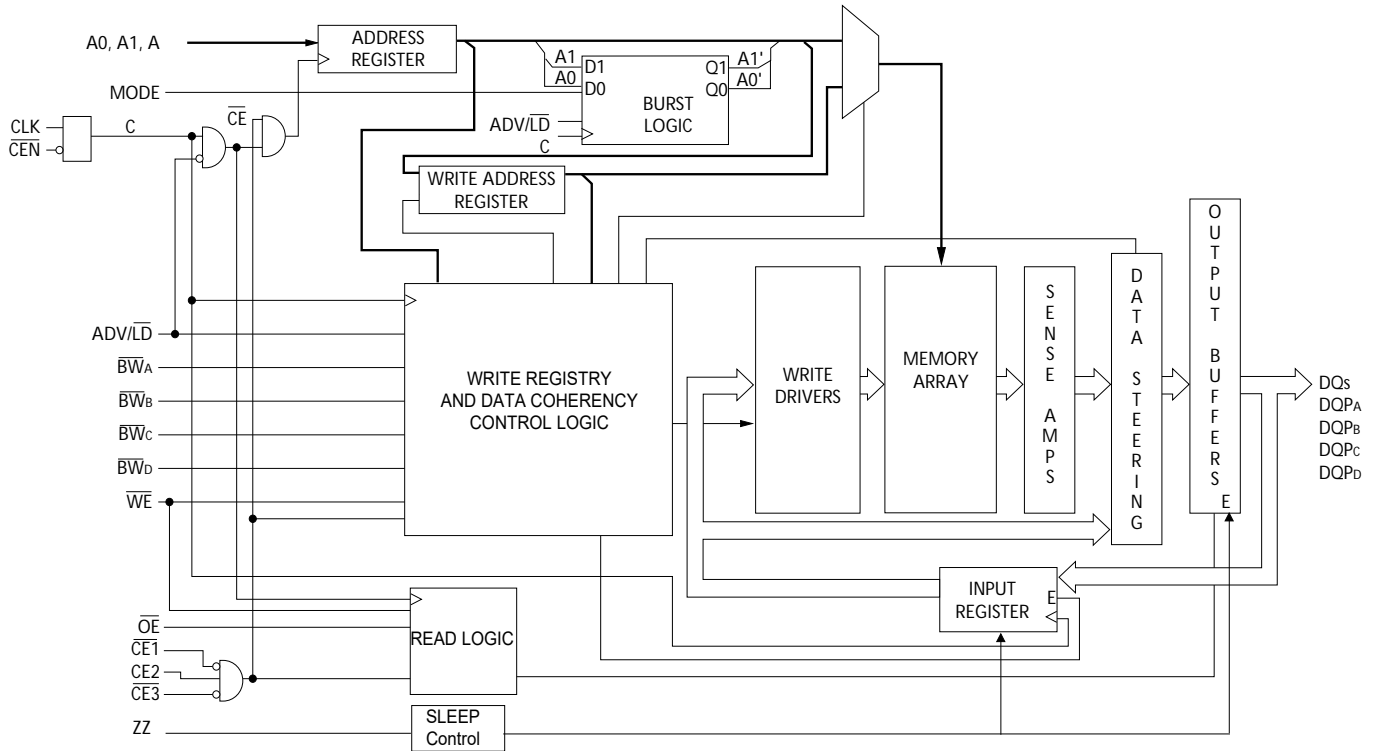

Contents

Pin Configurations	4	Switching Characteristics	13
Pin Definitions	5	Switching Waveforms	14
Functional Overview	7	Ordering Information	16
Single Read Accesses	7	Ordering Code Definitions	16
Burst Read Accesses	7	Package Diagrams	17
Single Write Accesses	7	Acronyms	18
Burst Write Accesses	7	Document Conventions	18
Sleep Mode	7	Units of Measure	18
Linear Burst Address Table	8	Errata	19
Interleaved Burst Address Table	8	Part Numbers Affected	19
ZZ Mode Electrical Characteristics	8	Product Status	19
Truth Table	9	Ram9 NoBL ZZ Pin Issues Errata Summary	19
Partial Truth Table for Read/Write	9	Document History Page	20
Maximum Ratings	10	Sales, Solutions, and Legal Information	23
Operating Range	10	Worldwide Sales and Design Support	23
Electrical Characteristics	10	Products	23
Capacitance	11	PSoC® Solutions	23
Thermal Resistance	11	Cypress Developer Community	23
AC Test Loads and Waveforms	12	Technical Support	23

Pin Configurations

Figure 1. 100-pin TQFP (14 × 20 × 1.4 mm) pinout [1]

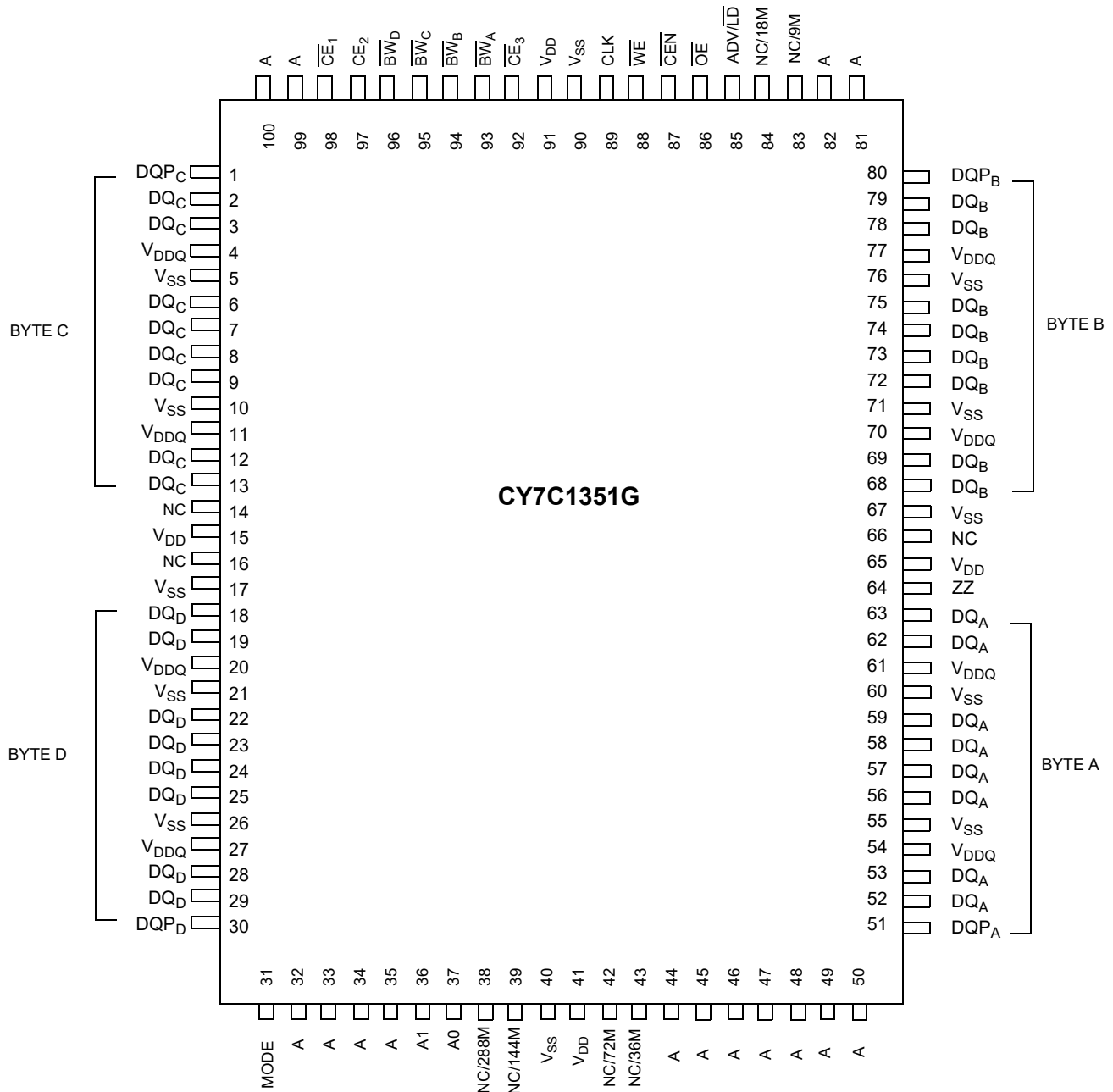

Note

1. **Errata:** The ZZ pin (Pin 64) needs to be externally connected to ground. For more information, see "Errata" on page 19.

Pin Definitions

Name	I/O	Description
A ₀ , A ₁ , A	Input-synchronous	Address inputs used to select one of the 128 K address locations. Sampled at the rising edge of the CLK. A _[1:0] are fed to the two-bit burst counter.
BW _[A:D]	Input-synchronous	Byte write inputs, active LOW. Qualified with \overline{WE} to conduct writes to the SRAM. Sampled on the rising edge of CLK.
\overline{WE}	Input-synchronous	Write enable input, active LOW. Sampled on the rising edge of CLK if \overline{CEN} is active LOW. This signal must be asserted LOW to initiate a write sequence.
ADV/LD	Input-synchronous	Advance/load input. Used to advance the on-chip address counter or load a new address. When HIGH (and \overline{CEN} is asserted LOW) the internal burst counter is advanced. When LOW, a new address can be loaded into the device for an access. After being deselected, ADV/LD should be driven LOW in order to load a new address.
CLK	Input-clock	Clock input. Used to capture all synchronous inputs to the device. CLK is qualified with \overline{CEN} . CLK is only recognized if \overline{CEN} is active LOW.
\overline{CE}_1	Input-synchronous	Chip enable 1 input, active LOW. Sampled on the rising edge of CLK. Used in conjunction with \overline{CE}_2 and \overline{CE}_3 to select/deselect the device.
\overline{CE}_2	Input-synchronous	Chip enable 2 input, active HIGH. Sampled on the rising edge of CLK. Used in conjunction with \overline{CE}_1 and \overline{CE}_3 to select/deselect the device.
\overline{CE}_3	Input-synchronous	Chip enable 3 input, active LOW. Sampled on the rising edge of CLK. Used in conjunction with \overline{CE}_1 and \overline{CE}_2 to select/deselect the device.
\overline{OE}	Input-asynchronous	Output enable, asynchronous input, active LOW. Combined with the synchronous logic block inside the device to control the direction of the I/O pins. When LOW, the I/O pins are allowed to behave as outputs. When deasserted HIGH, I/O pins are tristated, and act as input data pins. \overline{OE} is masked during the data portion of a write sequence, during the first clock when emerging from a deselected state, when the device has been deselected.
\overline{CEN}	Input-synchronous	Clock enable input, active LOW. When asserted LOW the clock signal is recognized by the SRAM. When deasserted HIGH the clock signal is masked. Since deasserting \overline{CEN} does not deselect the device, \overline{CEN} can be used to extend the previous cycle when required.
ZZ ^[2]	Input-asynchronous	ZZ "sleep" input. This active HIGH input places the device in a non-time critical "sleep" condition with data integrity preserved. During normal operation, this pin has to be low or left floating. ZZ pin has an internal pull-down.

Note

- Errata:** The ZZ pin (Pin 64) needs to be externally connected to ground. For more information, see "Errata" on page 19.

Pin Definitions (continued)

Name	I/O	Description
DQ _s	I/O-synchronous	Bidirectional data I/O lines. As inputs, they feed into an on-chip data register that is triggered by the rising edge of CLK. As outputs, they deliver the data contained in the memory location specified by address during the clock rise of the read cycle. The direction of the pins is controlled by OE and the internal control logic. When OE is asserted LOW, the pins can behave as outputs. When HIGH, DQ _s and DQP _[A:D] are placed in a tristate condition. The outputs are automatically tristated during the data portion of a write sequence, during the first clock when emerging from a deselected state, and when the device is deselected, regardless of the state of OE.
DQP _[A:D]	I/O-synchronous	Bidirectional data parity I/O lines. Functionally, these signals are identical to DQ _s . During write sequences, DQP _[A:D] is controlled by BW _[A:D] correspondingly.
MODE	Input strap pin	Mode input. Selects the burst order of the device. When tied to GND selects linear burst sequence. When tied to V _{DD} or left floating selects interleaved burst sequence.
V _{DD}	Power supply	Power supply inputs to the core of the device.
V _{DDQ}	I/O power supply	Power supply for the I/O circuitry.
V _{SS}	Ground	Ground for the device.
NC	–	No connects. Not Internally connected to the die.
NC/9M, NC/18M, NC/36M, NC/72M, NC/144M, NC/288M, NC/576M, NC/1G	–	No connects. Not internally connected to the die. NC/9M, NC/18M, NC/36M, NC/72M, NC/144M, NC/288M, NC/576M and NC/1G are address expansion pins are not internally connected to the die.

Functional Overview

The CY7C1351G is a synchronous flow-through burst SRAM designed specifically to eliminate wait states during write-read transitions. All synchronous inputs pass through input registers controlled by the rising edge of the clock. The clock signal is qualified with the clock enable input signal (\overline{CEN}). If \overline{CEN} is HIGH, the clock signal is not recognized and all internal states are maintained. All synchronous operations are qualified with \overline{CEN} . Maximum access delay from the clock rise (t_{CDV}) is 6.5 ns (133-MHz device).

Accesses can be initiated by asserting all three chip enables (\overline{CE}_1 , \overline{CE}_2 , \overline{CE}_3) active at the rising edge of the clock. If clock enable (\overline{CEN}) is active LOW and $\overline{ADV/LD}$ is asserted LOW, the address presented to the device will be latched. The access can either be a read or write operation, depending on the status of the write enable (\overline{WE}). $BW_{[A:D]}$ can be used to conduct byte write operations.

Write operations are qualified by the write enable (\overline{WE}). All writes are simplified with on-chip synchronous self-timed write circuitry.

Three synchronous chip enables (\overline{CE}_1 , \overline{CE}_2 , \overline{CE}_3) and an asynchronous output enable (\overline{OE}) simplify depth expansion. All operations (reads, writes, and deselections) are pipelined. $\overline{ADV/LD}$ should be driven LOW once the device has been deselected in order to load a new address for the next operation.

Single Read Accesses

A read access is initiated when the following conditions are satisfied at clock rise: (1) \overline{CEN} is asserted LOW, (2) \overline{CE}_1 , \overline{CE}_2 , and \overline{CE}_3 are all asserted active, (3) the write enable input signal \overline{WE} is deasserted HIGH, and (4) $\overline{ADV/LD}$ is asserted LOW. The address presented to the address inputs is latched into the address register and presented to the memory array and control logic. The control logic determines that a read access is in progress and allows the requested data to propagate to the output buffers. The data is available within 6.5 ns (133-MHz device) provided \overline{OE} is active LOW. After the first clock of the read access, the output buffers are controlled by \overline{OE} and the internal control logic. \overline{OE} must be driven LOW in order for the device to drive out the requested data. On the subsequent clock, another operation (read/write/deselect) can be initiated. When the SRAM is deselected at clock rise by one of the chip enable signals, its output will be tristated immediately.

Burst Read Accesses

The CY7C1351G has an on-chip burst counter that allows the user the ability to supply a single address and conduct up to four reads without reasserting the address inputs. $\overline{ADV/LD}$ must be driven LOW in order to load a new address into the SRAM, as described in the [Single Read Accesses](#) section above. The sequence of the burst counter is determined by the \overline{MODE} input signal. A LOW input on \overline{MODE} selects a linear burst mode, a HIGH selects an interleaved burst sequence. Both burst counters use A0 and A1 in the burst sequence, and will wrap around when incremented sufficiently. A HIGH input on $\overline{ADV/LD}$ will increment the internal burst counter regardless of the state of chip enable inputs or \overline{WE} . \overline{WE} is latched at the beginning of a burst cycle. Therefore, the type of access (read or write) is maintained throughout the burst sequence.

Single Write Accesses

Write access are initiated when the following conditions are satisfied at clock rise: (1) \overline{CEN} is asserted LOW, (2) \overline{CE}_1 , \overline{CE}_2 , and \overline{CE}_3 are all asserted active, and (3) the write signal \overline{WE} is asserted LOW. The address presented to the address bus is loaded into the address register. The write signals are latched into the control logic block. The data lines are automatically tristated regardless of the state of the \overline{OE} input signal. This allows the external logic to present the data on DQs and $DQP_{[A:D]}$.

On the next clock rise the data presented to DQs and $DQP_{[A:D]}$ (or a subset for byte write operations, see truth table for details) inputs is latched into the device and the write is complete. Additional accesses (read/write/deselect) can be initiated on this cycle.

The data written during the write operation is controlled by $BW_{[A:D]}$ signals. The CY7C1351G provides byte write capability that is described in the truth table. Asserting the write enable input (\overline{WE}) with the selected byte write select input will selectively write to only the desired bytes. Bytes not selected during a byte write operation will remain unaltered. A synchronous self-timed write mechanism has been provided to simplify the write operations. Byte write capability has been included in order to greatly simplify read/modify/write sequences, which can be reduced to simple byte write operations.

Because the CY7C1351G is a common I/O device, data should not be driven into the device while the outputs are active. The output enable (\overline{OE}) can be deasserted HIGH before presenting data to the DQs and $DQP_{[A:D]}$ inputs. Doing so will tristate the output drivers. As a safety precaution, DQs and $DQP_{[A:D]}$ are automatically tristated during the data portion of a write cycle, regardless of the state of \overline{OE} .

Burst Write Accesses

The CY7C1351G has an on-chip burst counter that allows the user the ability to supply a single address and conduct up to four Write operations without reasserting the address inputs. $\overline{ADV/LD}$ must be driven LOW in order to load the initial address, as described in the [Single Write Accesses](#) section above. When $\overline{ADV/LD}$ is driven HIGH on the subsequent clock rise, the chip enables (\overline{CE}_1 , \overline{CE}_2 , and \overline{CE}_3) and \overline{WE} inputs are ignored and the burst counter is incremented. The correct $BW_{[A:D]}$ inputs must be driven in each cycle of the burst write, in order to write the correct bytes of data.

Sleep Mode

The ZZ input pin is an asynchronous input. Asserting ZZ places the SRAM in a power conservation "sleep" mode. Two clock cycles are required to enter into or exit from this "sleep" mode. While in this mode, data integrity is guaranteed. Accesses pending when entering the "sleep" mode are not considered valid nor is the completion of the operation guaranteed. The device must be deselected prior to entering the "sleep" mode. \overline{CE}_1 , \overline{CE}_2 , and \overline{CE}_3 , must remain inactive for the duration of t_{ZZREC} after the ZZ input returns LOW.

Linear Burst Address Table

(MODE = GND)

First Address A1:A0	Second Address A1:A0	Third Address A1:A0	Fourth Address A1:A0
00	01	10	11
01	10	11	00
10	11	00	01
11	00	01	10

Interleaved Burst Address Table

 (MODE = Floating or V_{DD})

First Address A1:A0	Second Address A1:A0	Third Address A1:A0	Fourth Address A1:A0
00	01	10	11
01	00	11	10
10	11	00	01
11	10	01	00

ZZ Mode Electrical Characteristics

Parameter	Description	Test Conditions	Min	Max	Unit
I_{DDZZ}	Sleep mode standby current	$ZZ \geq V_{DD} - 0.2 V$	–	40	mA
t_{ZZS}	Device operation to ZZ	$ZZ \geq V_{DD} - 0.2 V$	–	$2t_{CYC}$	ns
t_{ZZREC}	ZZ recovery time	$ZZ \leq 0.2 V$	$2t_{CYC}$	–	ns
t_{ZZI}	ZZ active to sleep current	This parameter is sampled	–	$2t_{CYC}$	ns
t_{RZZI}	ZZ inactive to exit sleep current	This parameter is sampled	0	–	ns

Truth Table

The truth table for CY7C1351G follows. [3, 4, 5, 6, 7, 8, 9]

Operation	Address Used	\overline{CE}_1	CE_2	\overline{CE}_3	ZZ	ADV/LD	\overline{WE}	\overline{BW}_x	\overline{OE}	\overline{CEN}	CLK	DQ
Deselect cycle	None	H	X	X	L	L	X	X	X	L	L->H	Tristate
Deselect cycle	None	X	X	H	L	L	X	X	X	L	L->H	Tristate
Deselect cycle	None	X	L	X	L	L	X	X	X	L	L->H	Tristate
Continue deselect cycle	None	X	X	X	L	H	X	X	X	L	L->H	Tristate
READ cycle (begin burst)	External	L	H	L	L	L	H	X	L	L	L->H	Data out (Q)
READ cycle (continue burst)	Next	X	X	X	L	H	X	X	L	L	L->H	Data out (Q)
NOP/DUMMY READ (begin burst)	External	L	H	L	L	L	H	X	H	L	L->H	Tristate
DUMMY READ (continue burst)	Next	X	X	X	L	H	X	X	H	L	L->H	Tristate
WRITE cycle (begin burst)	External	L	H	L	L	L	L	L	X	L	L->H	Data in (D)
WRITE cycle (continue burst)	Next	X	X	X	L	H	X	L	X	L	L->H	Data in (D)
NOP/WRITE ABORT (begin burst)	None	L	H	L	L	L	L	H	X	L	L->H	Tristate
WRITE ABORT (continue burst)	Next	X	X	X	L	H	X	H	X	L	L->H	Tristate
IGNORE CLOCK EDGE (stall)	Current	X	X	X	L	X	X	X	X	H	L->H	-
SLEEP MODE	None	X	X	X	H	X	X	X	X	X	X	Tristate

Partial Truth Table for Read/Write

The Partial Truth Table for Read/Write for CY7C1351G follows. [3, 4, 10]

Function	\overline{WE}	\overline{BW}_A	\overline{BW}_B	\overline{BW}_C	\overline{BW}_D
Read	H	X	X	X	X
Read	H	X	X	X	X
Write – no bytes written	L	H	H	H	H
Write byte A – (DQ _A and DQP _A)	L	L	H	H	H
Write byte B – (DQ _B and DQP _B)	L	H	L	H	H
Write byte C – (DQ _C and DQP _C)	L	H	H	L	H
Write byte D – (DQ _D and DQP _D)	L	H	H	H	L
Write all bytes	L	L	L	L	L

Notes

- X = "Don't Care." H = Logic HIGH, L = Logic LOW. \overline{BW}_x = L signifies at least one byte write select is active, \overline{BW}_x = valid signifies that the desired byte write selects are asserted, see truth table for details.
- Write is defined by \overline{BW}_x , and \overline{WE} . See truth table for read/write.
- When a write cycle is detected, all I/Os are tristated, even during byte writes.
- The DQs and DQP_[A:D] pins are controlled by the current cycle and the \overline{OE} signal. \overline{OE} is asynchronous and is not sampled with the clock.
- \overline{CEN} = H, inserts wait states.
- Device will power-up deselected and the I/Os in a tristate condition, regardless of \overline{OE} .
- \overline{OE} is asynchronous and is not sampled with the clock rise. It is masked internally during write cycles. During a read cycle DQs and DQP_[A:D] = tristate when \overline{OE} is inactive or when the device is deselected, and DQs and DQP_[A:D] = data when \overline{OE} is active.
- Table only lists a partial listing of the byte write combinations. Any combination of \overline{BW}_x is valid. Appropriate write will be done based on which byte write is active.

Maximum Ratings

Exceeding maximum ratings may shorten the useful life of the device. User guidelines are not tested.

Storage temperature	-65 °C to +150 °C
Ambient temperature with power applied	-55 °C to +125 °C
Supply voltage on V _{DD} relative to GND	-0.5 V to +4.6 V
Supply voltage on V _{DDQ} relative to GND	-0.5 V to +V _{DD}
DC voltage applied to outputs in tristate	-0.5 V to V _{DDQ} + 0.5 V

DC input voltage	-0.5 V to V _{DD} + 0.5 V
Current into outputs (LOW)	20 mA
Static discharge voltage (per MIL-STD-883, method 3015)	> 2001 V
Latch up current	> 200 mA

Operating Range

Range	Ambient Temperature (T _A)	V _{DD}	V _{DDQ}
Commercial	0 °C to +70 °C	3.3 V – 5% / + 10%	2.5 V – 5% to V _{DD}

Electrical Characteristics

Over the Operating Range

Parameter ^[11, 12]	Description	Test Conditions	Min	Max	Unit	
V _{DD}	Power supply voltage		3.135	3.6	V	
V _{DDQ}	I/O supply voltage	For 3.3 V I/O	3.135	V _{DD}	V	
		For 2.5 V I/O	2.375	2.625	V	
V _{OH}	Output HIGH voltage	For 3.3 V I/O, I _{OH} = -4.0 mA	2.4	-	V	
		For 2.5 V I/O, I _{OH} = -1.0 mA	2.0	-	V	
V _{OL}	Output LOW voltage	For 3.3 V I/O, I _{OL} = 8.0 mA	-	0.4	V	
		For 2.5 V I/O, I _{OL} = 1.0 mA	-	0.4	V	
V _{IH}	Input HIGH voltage	For 3.3 V I/O	2.0	V _{DD} + 0.3	V	
	Input HIGH voltage	For 2.5 V I/O	1.7	V _{DD} + 0.3	V	
V _{IL}	Input LOW voltage ^[11]	For 3.3 V I/O	-0.3	0.8	V	
	Input LOW voltage ^[11]	For 2.5 V I/O	-0.3	0.7	V	
I _X	Input leakage current except ZZ and MODE	GND ≤ V _I ≤ V _{DDQ}	-5	5	μA	
	Input current of MODE	Input = V _{SS}	-30	-	μA	
		Input = V _{DD}	-	5	μA	
	Input current of ZZ	Input = V _{SS}	-5	-	μA	
Input = V _{DD}		-	30	μA		
I _{OZ}	Output leakage current	GND ≤ V _I ≤ V _{DDQ} , output disabled	-5	5	μA	
I _{DD}	V _{DD} operating supply current	V _{DD} = Max, I _{OUT} = 0 mA, f = f _{MAX} = 1/t _{CYC}	7.5-ns cycle, 133 MHz	-	225	mA
			10-ns cycle, 100 MHz	-	205	mA
I _{SB1}	Automatic CE power-down current – TTL inputs	V _{DD} = Max, device deselected, V _{IN} ≥ V _{IH} or V _{IN} ≤ V _{IL} , f = f _{MAX} , inputs switching	7.5-ns cycle, 133 MHz	-	90	mA
			10-ns cycle, 100 MHz	-	80	mA
I _{SB2}	Automatic CE power-down current – CMOS inputs	V _{DD} = Max, device deselected, V _{IN} ≥ V _{DD} - 0.3 V or V _{IN} ≤ 0.3 V, f = 0, inputs static	-	40	mA	

Notes

11. Overshoot: V_{IH(AC)} < V_{DD} + 1.5 V (Pulse width less than t_{CYC}/2), undershoot: V_{IL(AC)} > -2 V (Pulse width less than t_{CYC}/2).
 12. T_{Power-up}: Assumes a linear ramp from 0 V to V_{DD(min.)} within 200 ms. During this time V_{IH} < V_{DD} and V_{DDQ} ≤ V_{DD}.

Electrical Characteristics *(continued)*

Over the Operating Range

Parameter ^[11, 12]	Description	Test Conditions	Min	Max	Unit	
I _{SB3}	Automatic CE power-down current – CMOS inputs	V _{DD} = Max, device deselected, V _{IN} ≥ V _{DDQ} – 0.3 V or V _{IN} ≤ 0.3 V, f = f _{MAX} , inputs switching	7.5-ns cycle, 133 MHz	–	75	mA
			10-ns cycle, 100 MHz	–	65	mA
I _{SB4}	Automatic CE power-down current – TTL inputs	V _{DD} = Max, device deselected, V _{IN} ≥ V _{IH} or V _{IN} ≤ V _{IL} , f = 0, inputs static	–	45	mA	

Capacitance

Parameter ^[13]	Description	Test Conditions	100-pin TQFP Max	Unit
C _{IN}	Input capacitance	T _A = 25 °C, f = 1 MHz, V _{DD} = 3.3 V, V _{DDQ} = 3.3 V	5	pF
C _{CLOCK}	Clock input capacitance		5	pF
C _{I/O}	I/O capacitance		5	pF

Thermal Resistance

Parameter ^[13]	Description	Test Conditions	100-pin TQFP Package	Unit
Θ _{JA}	Thermal resistance (junction to ambient)	Test conditions follow standard test methods and procedures for measuring thermal impedance, per EIA/JESD51.	30.32	°C/W
Θ _{JC}	Thermal resistance (junction to case)		6.85	°C/W

Note

13. Tested initially and after any design or process changes that may affect these parameters.

AC Test Loads and Waveforms

Figure 2. AC Test Loads and Waveforms

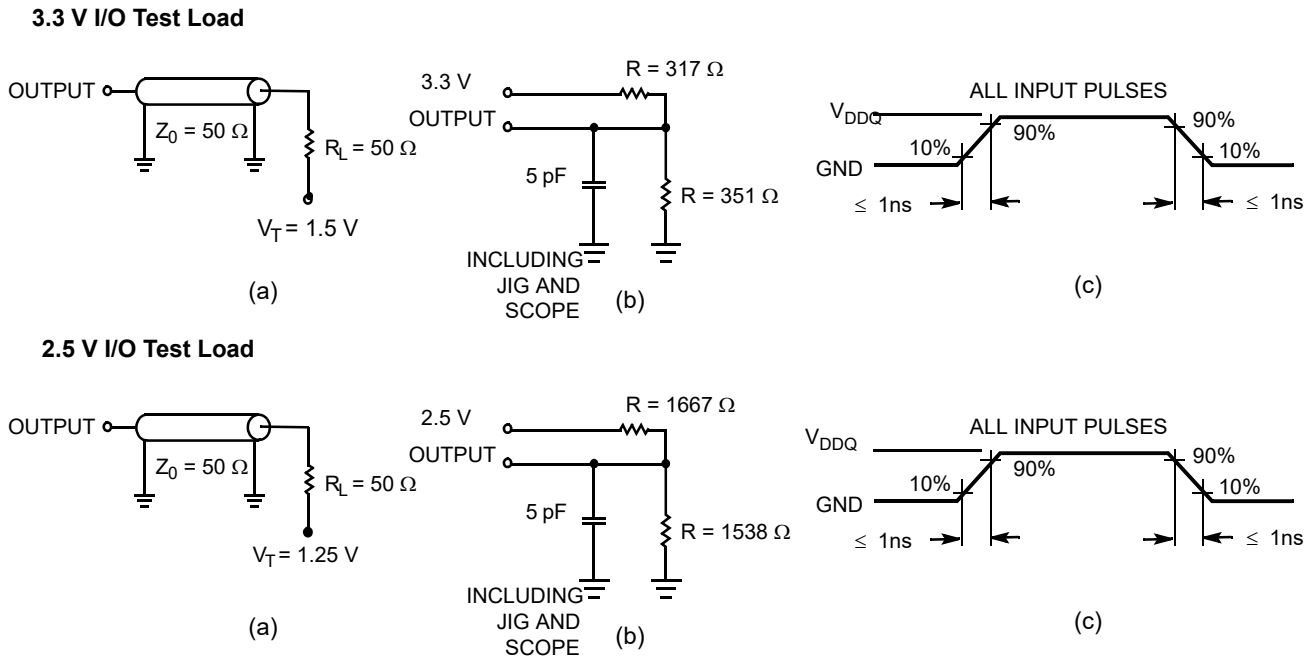

Switching Characteristics

Over the Operating Range

Parameter ^[14, 15]	Description	-133		-100		Unit
		Min	Max	Min	Max	
t _{POWER}	V _{DD} (typical) to the first access ^[16]	1	–	1	–	ms
Clock						
t _{CYC}	Clock cycle time	7.5	–	10	–	ns
t _{CH}	Clock HIGH	2.5	–	4.0	–	ns
t _{CL}	Clock LOW	2.5	–	4.0	–	ns
Output Times						
t _{CDV}	Data output valid after CLK rise	–	6.5	–	8.0	ns
t _{DOH}	Data output hold after CLK rise	2.0	–	2.0	–	ns
t _{CLZ}	Clock to low Z ^[17, 18, 19]	0	–	0	–	ns
t _{CHZ}	Clock to high Z ^{17, 18, 19]}	–	3.5	–	3.5	ns
t _{OE\bar{V}}	\overline{OE} LOW to output valid	–	3.5	–	3.5	ns
t _{OE\bar{L}Z}	\overline{OE} LOW to output low Z ^[17, 18, 19]	0	–	0	–	ns
t _{OE\bar{H}Z}	\overline{OE} HIGH to output high Z ^[17, 18, 19]	–	3.5	–	3.5	ns
Set-up Times						
t _{AS}	Address set-up before CLK rise	1.5	–	2.0	–	ns
t _{ALS}	ADV/LD set-up before CLK rise	1.5	–	2.0	–	ns
t _{WES}	\overline{WE} , \overline{BW}_X set-up before CLK rise	1.5	–	2.0	–	ns
t _{CENS}	\overline{CEN} set-up before CLK rise	1.5	–	2.0	–	ns
t _{DS}	Data input set-up before CLK rise	1.5	–	2.0	–	ns
t _{CES}	Chip enable set-up before CLK rise	1.5	–	2.0	–	ns
Hold Times						
t _{AH}	Address hold after CLK rise	0.5	–	0.5	–	ns
t _{ALH}	ADV/LD hold after CLK rise	0.5	–	0.5	–	ns
t _{WEH}	\overline{WE} , \overline{BW}_X hold after CLK rise	0.5	–	0.5	–	ns
t _{CENH}	\overline{CEN} hold after CLK rise	0.5	–	0.5	–	ns
t _{DH}	Data input hold after CLK rise	0.5	–	0.5	–	ns
t _{CEH}	Chip enable hold after CLK rise	0.5	–	0.5	–	ns

Notes

14. Timing reference level is 1.5 V when V_{DDQ} = 3.3 V and is 1.25 V when V_{DDQ} = 2.5 V.
15. Test conditions shown in (a) of [Figure 2 on page 12](#), unless otherwise noted.
16. This part has a voltage regulator internally; t_{POWER} is the time that the power needs to be supplied above V_{DD(minimum)} initially before a read or write operation can be initiated.
17. t_{CHZ}, t_{CLZ}, t_{OE \bar{L} Z}, and t_{OE \bar{H} Z} are specified with AC test conditions shown in part (b) of [Figure 2 on page 12](#). Transition is measured ±200 mV from steady-state voltage.
18. At any given voltage and temperature, t_{OE \bar{H} Z} is less than t_{OE \bar{L} Z} and t_{CHZ} is less than t_{CLZ} to eliminate bus contention between SRAMs when sharing the same data bus. These specifications do not imply a bus contention condition, but reflect parameters guaranteed over worst case user conditions. Device is designed to achieve tristate prior to low Z under the same system conditions.
19. This parameter is sampled and not 100% tested.

Switching Waveforms

Figure 3. Read/Write Waveforms [20, 21, 22]

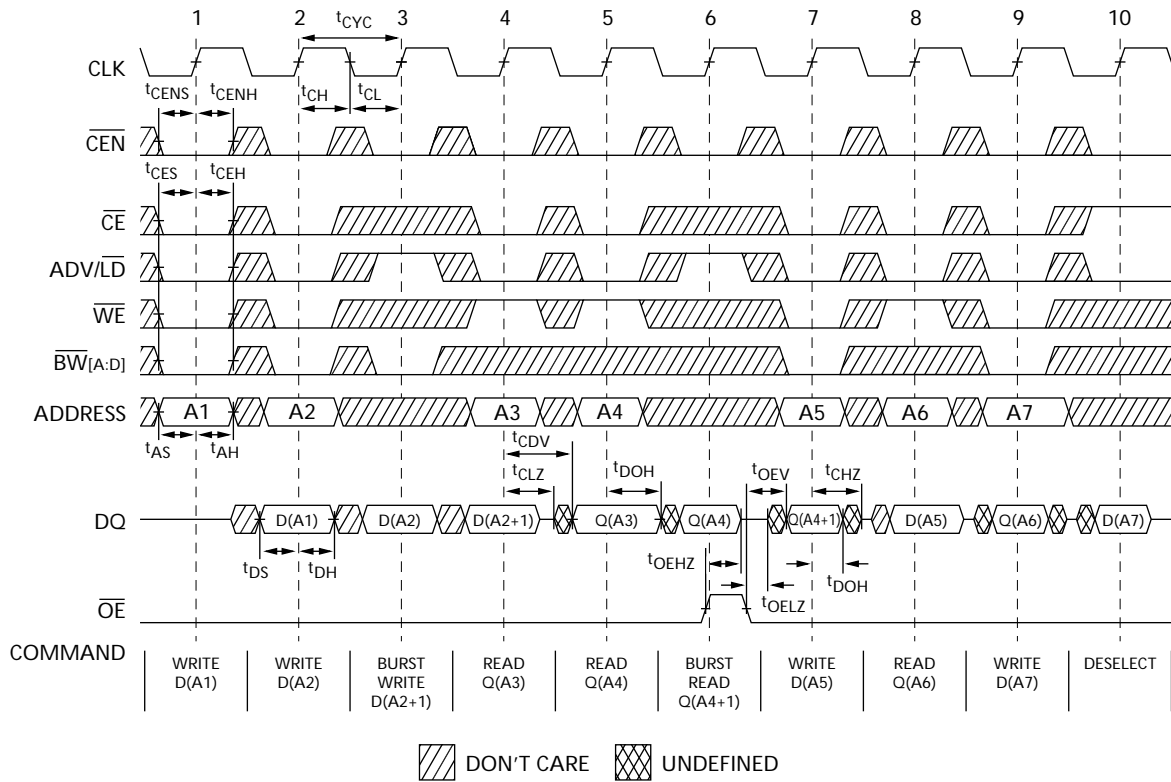

Notes

- 20. For this waveform ZZ is tied LOW.
- 21. When CE is LOW, CE₁ is LOW, CE₂ is HIGH and CE₃ is LOW. When CE is HIGH, CE₁ is HIGH or CE₂ is LOW or CE₃ is HIGH.
- 22. Order of the burst sequence is determined by the status of the MODE (0 = Linear, 1 = Interleaved). Burst operations are optional.

Switching Waveforms (continued)

Figure 4. NOP, STALL and DESELECT Cycles [23, 24, 25]

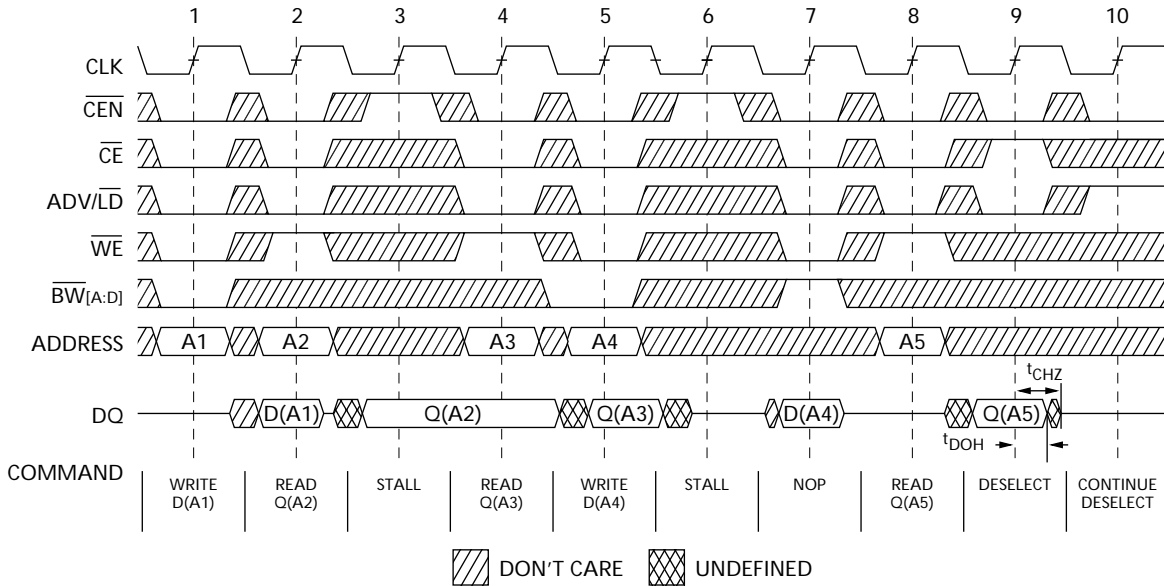
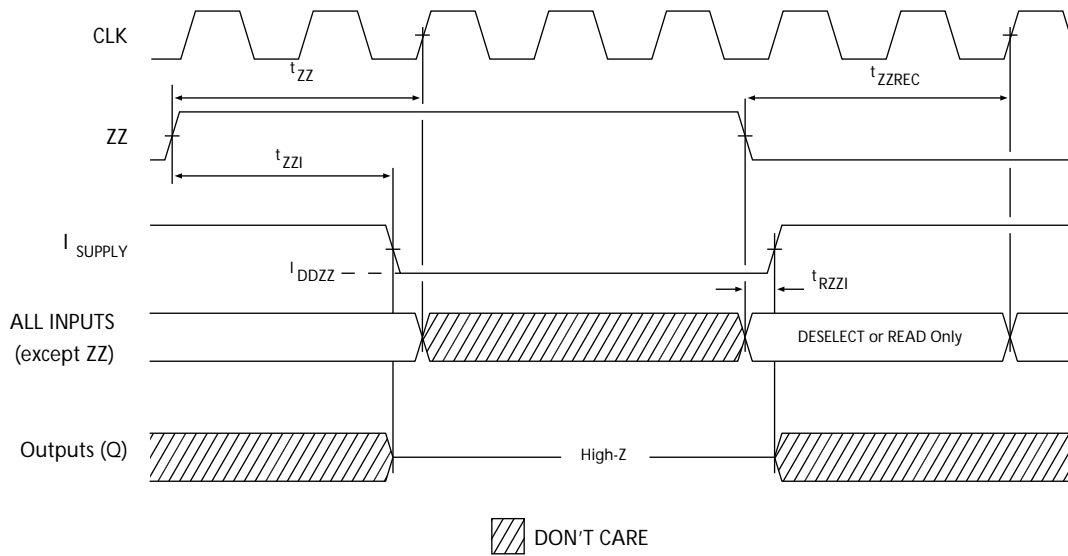

Figure 5. ZZ Mode Timing [26, 27]



Notes

- 23. For this waveform ZZ is tied LOW.
- 24. When \overline{CE} is LOW, \overline{CE}_1 is LOW, CE_2 is HIGH and \overline{CE}_3 is LOW. When \overline{CE} is HIGH, \overline{CE}_1 is HIGH or CE_2 is LOW or \overline{CE}_3 is HIGH.
- 25. The IGNORE CLOCK EDGE or STALL cycle (Clock 3) illustrates \overline{CEN} being used to create a pause. A write is not performed during this cycle.
- 26. Device must be deselected when entering ZZ mode. See truth table for all possible signal conditions to deselect the device.
- 27. DQs are in high Z when exiting ZZ sleep mode.

Ordering Information

Cypress offers other versions of this type of product in many different configurations and features. The following table contains only the list of parts that are currently available.

For a complete listing of all options, visit the Cypress website at www.cypress.com and refer to the product summary page at <http://www.cypress.com/products> or contact your local sales representative.

Cypress maintains a worldwide network of offices, solution centers, manufacturer's representatives and distributors. To find the office closest to you, visit us at <http://www.cypress.com/go/datasheet/offices>.

Speed (MHz)	Ordering Code	Package Diagram	Part and Package Type	Operating Range
100	CY7C1351G-100AXC	51-85050	100-pin TQFP (14 × 20 × 1.4 mm) Pb-free	Commercial
133	CY7C1351G-133AXC	51-85050	100-pin TQFP (14 × 20 × 1.4 mm) Pb-free	

Ordering Code Definitions

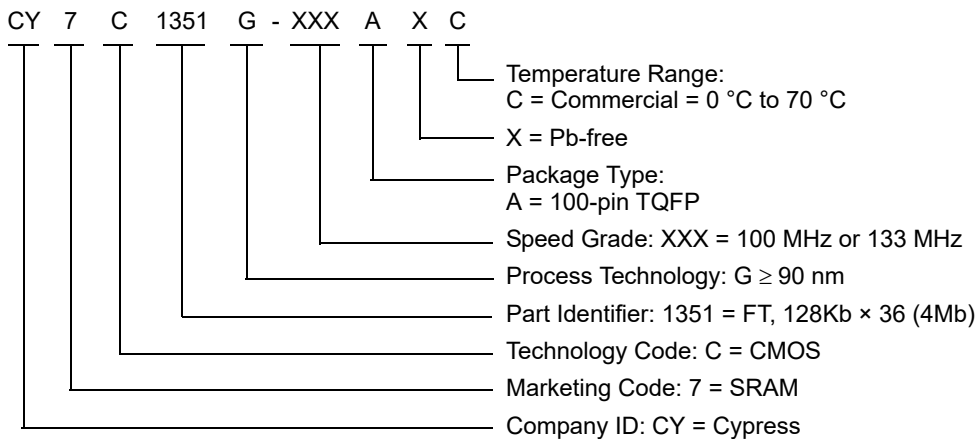

Acronyms

Acronym	Description
CMOS	Complementary Metal Oxide Semiconductor
$\overline{\text{CE}}$	Chip Enable
CEN	Clock Enable
EIA	Electronics Industries Alliance
I/O	Input/Output
JEDEC	Joint Electron Devices Engineering Council
NoBL	No Bus Latency
$\overline{\text{OE}}$	Output Enable
SRAM	Static Random Access Memory
TQFP	Thin Quad Flat Pack
TTL	Transistor-Transistor Logic
$\overline{\text{WE}}$	Write Enable

Document Conventions

Units of Measure

Symbol	Unit of Measure
°C	degree Celsius
MHz	megahertz
μA	microampere
mA	milliampere
mm	millimeter
ms	millisecond
ns	nanosecond
%	percent
pF	picofarad
V	volt
W	watt

Errata

This section describes the Ram9 NoBL ZZ pin issue. Details include trigger conditions, the devices affected, proposed workaround and silicon revision applicability. Please contact your local Cypress sales representative if you have further questions.

Part Numbers Affected

Density & Revision	Package Type	Operating Range
4Mb-Ram9 NoBL™ SRAMs: CY7C135*G	100-pin TQFP	Commercial

Product Status

All of the devices in the Ram9 4Mb NoBL family are qualified and available in production quantities.

Ram9 NoBL ZZ Pin Issues Errata Summary

The following table defines the errata applicable to available Ram9 4Mb NoBL family devices.

Item	Issues	Description	Device	Fix Status
1.	ZZ Pin	When asserted HIGH, the ZZ pin places device in a “sleep” condition with data integrity preserved. The ZZ pin currently does not have an internal pull-down resistor and hence cannot be left floating externally by the user during normal mode of operation.	4M-Ram9 (90 nm)	For the 4M Ram9 (90 nm) devices, there is no plan to fix this issue.

1. ZZ Pin Issue

■ PROBLEM DEFINITION

The problem occurs only when the device is operated in the normal mode with ZZ pin left floating. The ZZ pin on the SRAM device does not have an internal pull-down resistor. Switching noise in the system may cause the SRAM to recognize a HIGH on the ZZ input, which may cause the SRAM to enter sleep mode. This could result in incorrect or undesirable operation of the SRAM.

■ TRIGGER CONDITIONS

Device operated with ZZ pin left floating.

■ SCOPE OF IMPACT

When the ZZ pin is left floating, the device delivers incorrect data.

■ WORKAROUND

Tie the ZZ pin externally to ground.

■ FIX STATUS

For the 4M Ram9 (90 nm) devices, there is no plan to fix this issue.

Document History Page

Document Title: CY7C1351G, 4-Mbit (128K × 36) Flow-Through SRAM with NoBL™ Architecture				
Document Number: 38-05513				
Rev.	ECN No.	Orig. of Change	Submission Date	Description of Change
**	224360	RKF	05/17/2004	New data sheet.
*A	276690	VBL	10/14/2004	Removed 66 MHz frequency related information in all instances across the document. Updated Ordering Information (Updated part numbers; added comment of availability of BG lead-free package).
*B	333626	SYT	03/15/2005	Updated Features (Removed 117 MHz frequency related information). Updated Selection Guide (Removed 117 MHz frequency related information). Updated Pin Configurations (Modified Address Expansion balls in the pinouts for 100-pin TQFP and 119-ball BGA Packages as per JEDEC standards). Updated Pin Definitions . Updated Functional Overview (Updated ZZ Mode Electrical Characteristics (Replaced “Snooze” with “Sleep”)). Updated Electrical Characteristics (Updated Test Conditions of V_{OL} , V_{OH} parameters, removed 117 MHz frequency related information). Updated Truth Table (Replaced “Snooze” with “Sleep”). Updated Thermal Resistance (Replaced values of Θ_{JA} and Θ_{JC} parameters from TBD to respective Thermal Values for all Packages). Updated Switching Characteristics (Removed 117 MHz frequency related information). Updated Ordering Information (By shading and unshading MPNs as per availability; changed the package name for 100-pin TQFP from A100RA to A101).
*C	418633	R XU	01/06/2006	Changed status from Preliminary to Final. Changed address of Cypress Semiconductor Corporation from “3901 North First Street” to “198 Champion Court”. Updated Electrical Characteristics (Updated Note 12 (Modified test condition from $V_{DDQ} < V_{DD}$ to $V_{DDQ} \leq V_{DD}$), splitted V_{DDQ} parameter into two rows (one for 3.3 V I/O, another for 2.5 V I/O), Updated Test Conditions of V_{OL} , V_{OH} parameters (Changed Typo in Test Condition of V_{OH} parameter from “for 3.3 V I/O” to “for 3.3 V I/O, $I_{OH} = -4.0$ mA” and from “for 2.5 V I/O” to “for 2.5 V I/O, $I_{OH} = -1.0$ mA”, changed Typo in Test Condition of V_{OL} parameter from “for 3.3 V I/O, $I_{OH} = -4.0$ mA” to “for 3.3 V I/O, $I_{OH} = 8.0$ mA” and from “for 2.5 V I/O, $I_{OH} = -1.0$ mA” to “for 2.5 V I/O, $I_{OH} = 1.0$ mA”), updated Test Conditions of V_{IH} parameter (Changed Typo in Test Condition of V_{IH} parameter from “for 3.3 V I/O, $I_{OH} = 8.0$ mA” to “for 3.3 V I/O” and from “for 2.5 V I/O, $I_{OH} = 1.0$ mA” to “for 2.5 V I/O”), changed “Input Load Current except ZZ and MODE” to “Input Leakage Current except ZZ and MODE”, updated Test Conditions of I_X parameter (Changed Typo in Test Condition of I_X parameter (Corresponding to Input Load Current except ZZ and MODE) from “for 3.3 V” to “ $GND \leq V_I \leq V_{DDQ}$ ”, changed Typo in Test Condition of I_X parameter (Corresponding to Input Current of Mode) from “for 2.5 V I/O and “ $GND \leq V_I \leq V_{DDQ}$ ” to Input = V_{SS} and Input = V_{DD} respectively), updated Test Conditions of I_{SB4} parameter (Changed Typo in Test Condition of I_{SB4} parameter from “ $V_{IN} \geq V_{DDQ} - 0.3$ V or $V_{IN} \leq 0.3$ V” to “ $V_{IN} \geq V_{IH}$ or $V_{IN} \leq V_{IL}$ ”). Updated Ordering Information (Updated part numbers; replaced Package Name column with Package Diagram in the Ordering Information table). Updated Package Diagrams (spec 51-85050 (changed revision from *A to *B)).

Document History Page (continued)

Document Title: CY7C1351G, 4-Mbit (128K × 36) Flow-Through SRAM with NoBL™ Architecture				
Document Number: 38-05513				
Rev.	ECN No.	Orig. of Change	Submission Date	Description of Change
*D	480124	VKN	07/14/2006	Updated Maximum Ratings (Added the Maximum Rating for Supply Voltage on V _{DDQ} Relative to GND). Updated Ordering Information (Updated part numbers).
*E	2896584	NJY	03/20/2010	Updated Ordering Information (Updated part numbers). Updated Package Diagrams : spec 51-85050 – Changed revision from *B to *C. spec 51-85115 – Changed revision from *B to *C.
*F	3033272	NJY	09/19/2010	Updated Ordering Information : No change in part numbers. Added Ordering Code Definitions . Added Acronyms and Units of Measure . Minor edits. Updated to new template. Completing Sunset Review.
*G	3067198	NJY	10/20/2010	Updated Ordering Information (Updated part numbers).
*H	3096309	NJY	11/28/2010	Updated Functional Description : Updated description.
*I	3353119	PRIT	08/24/2011	Updated Functional Description (Updated the Note as “For best practice recommendations, refer to SRAM System Guidelines .”). Updated Package Diagrams (spec 51-85050 (changed revision from *C to *D)). Completing Sunset Review.
*J	3616656	PRIT	05/14/2012	Updated Features (Removed 119-ball BGA package related information). Updated Functional Description (Removed the Note “For best practice recommendations, refer to SRAM System Guidelines .” and its reference). Updated Pin Configurations (Removed 119-ball BGA package related information). Updated Operating Range (Removed Industrial Temperature Range). Updated Capacitance (Removed 119-ball BGA package related information). Updated Thermal Resistance (Removed 119-ball BGA package related information). Updated Package Diagrams (Removed 119-ball BGA package related information (spec 51-85115 Rev. *C)).
*K	3767562	PRIT	10/05/2012	No technical updates. Completing Sunset Review.
*L	3980362	PRIT	04/24/2013	Added Errata .
*M	4038283	PRIT	06/25/2013	Added Errata Footnotes. Updated to new template.
*N	4146701	PRIT	10/04/2013	Updated Errata .
*O	4540469	PRIT	10/16/2014	Updated Package Diagrams : spec 51-85050 – Changed revision from *D to *E. Completing Sunset Review.
*P	4572829	PRIT	11/18/2014	Updated Functional Description : Added “For a complete list of related documentation, click here .” at the end.
*Q	5508643	PRIT	11/03/2016	Updated Package Diagrams : spec 51-85050 – Changed revision from *E to *F. Updated to new template. Completing Sunset Review.

Document History Page *(continued)*

Document Title: CY7C1351G, 4-Mbit (128K × 36) Flow-Through SRAM with NoBL™ Architecture Document Number: 38-05513				
Rev.	ECN No.	Orig. of Change	Submission Date	Description of Change
*R	5999437	RMES	01/09/2018	Updated Ordering Information : No change in part numbers. Updated Ordering Code Definitions . Updated Package Diagrams : spec 51-85050 – Changed revision from *F to *G. Updated to new template. Completing Sunset Review.

Sales, Solutions, and Legal Information

Worldwide Sales and Design Support

Cypress maintains a worldwide network of offices, solution centers, manufacturer's representatives, and distributors. To find the office closest to you, visit us at [Cypress Locations](#).

Products

Arm® Cortex® Microcontrollers	cypress.com/arm
Automotive	cypress.com/automotive
Clocks & Buffers	cypress.com/clocks
Interface	cypress.com/interface
Internet of Things	cypress.com/iot
Memory	cypress.com/memory
Microcontrollers	cypress.com/mcu
PSoC	cypress.com/psoc
Power Management ICs	cypress.com/pmic
Touch Sensing	cypress.com/touch
USB Controllers	cypress.com/usb
Wireless Connectivity	cypress.com/wireless

PSoC® Solutions

[PSoC 1](#) | [PSoC 3](#) | [PSoC 4](#) | [PSoC 5LP](#) | [PSoC 6 MCU](#)

Cypress Developer Community

[Community](#) | [Projects](#) | [Video](#) | [Blogs](#) | [Training](#) | [Components](#)

Technical Support

cypress.com/support

© Cypress Semiconductor Corporation, 2004-2018. This document is the property of Cypress Semiconductor Corporation and its subsidiaries, including Spansion LLC ("Cypress"). This document, including any software or firmware included or referenced in this document ("Software"), is owned by Cypress under the intellectual property laws and treaties of the United States and other countries worldwide. Cypress reserves all rights under such laws and treaties and does not, except as specifically stated in this paragraph, grant any license under its patents, copyrights, trademarks, or other intellectual property rights. If the Software is not accompanied by a license agreement and you do not otherwise have a written agreement with Cypress governing the use of the Software, then Cypress hereby grants you a personal, non-exclusive, nontransferable license (without the right to sublicense) (1) under its copyright rights in the Software (a) for Software provided in source code form, to modify and reproduce the Software solely for use with Cypress hardware products, only internally within your organization, and (b) to distribute the Software in binary code form externally to end users (either directly or indirectly through resellers and distributors), solely for use on Cypress hardware product units, and (2) under those claims of Cypress's patents that are infringed by the Software (as provided by Cypress, unmodified) to make, use, distribute, and import the Software solely for use with Cypress hardware products. Any other use, reproduction, modification, translation, or compilation of the Software is prohibited.

TO THE EXTENT PERMITTED BY APPLICABLE LAW, CYPRESS MAKES NO WARRANTY OF ANY KIND, EXPRESS OR IMPLIED, WITH REGARD TO THIS DOCUMENT OR ANY SOFTWARE OR ACCOMPANYING HARDWARE, INCLUDING, BUT NOT LIMITED TO, THE IMPLIED WARRANTIES OF MERCHANTABILITY AND FITNESS FOR A PARTICULAR PURPOSE. To the extent permitted by applicable law, Cypress reserves the right to make changes to this document without further notice. Cypress does not assume any liability arising out of the application or use of any product or circuit described in this document. Any information provided in this document, including any sample design information or programming code, is provided only for reference purposes. It is the responsibility of the user of this document to properly design, program, and test the functionality and safety of any application made of this information and any resulting product. Cypress products are not designed, intended, or authorized for use as critical components in systems designed or intended for the operation of weapons, weapons systems, nuclear installations, life-support devices or systems, other medical devices or systems (including resuscitation equipment and surgical implants), pollution control or hazardous substances management, or other uses where the failure of the device or system could cause personal injury, death, or property damage ("Unintended Uses"). A critical component is any component of a device or system whose failure to perform can be reasonably expected to cause the failure of the device or system, or to affect its safety or effectiveness. Cypress is not liable, in whole or in part, and you shall and hereby do release Cypress from any claim, damage, or other liability arising from or related to all Unintended Uses of Cypress products. You shall indemnify and hold Cypress harmless from and against all claims, costs, damages, and other liabilities, including claims for personal injury or death, arising from or related to any Unintended Uses of Cypress products.

Cypress, the Cypress logo, Spansion, the Spansion logo, and combinations thereof, WICED, PSoC, CapSense, EZ-USB, F-RAM, and Traveo are trademarks or registered trademarks of Cypress in the United States and other countries. For a more complete list of Cypress trademarks, visit cypress.com. Other names and brands may be claimed as property of their respective owners.

Looking for pricing, stock, or lifecycle information?

Click below to explore more details on WIN SOURCE:

- [View CY7C1351G-100AXC on WIN SOURCE](#)
- [Cypress Semiconductor Corp Information](#)

Optimize Your Supply Chain with WIN SOURCE Solutions

- ✓ Global Sourcing Solution
- ✓ Obsolete Management
- ✓ Cost Control Management
- ✓ Shortage Management
- ✓ Alternative Solution
- ✓ Excess Inventory Management