



**THE DATASHEET OF  
CY7C1350G-200AXC**



# 4-Mbit (128K × 36) Pipelined SRAM with NoBL™ Architecture

## Features

- Pin compatible and functionally equivalent to ZBT™ devices
- Internally self-timed output buffer control to eliminate the need to use  $\overline{OE}$
- Byte write capability
- 128K × 36 common I/O architecture
- 3.3 V power supply ( $V_{DD}$ )
- 2.5 V/3.3 V I/O power supply ( $V_{DDQ}$ )
- Fast clock-to-output times
  - 2.8 ns (for 200 MHz device)
- Clock enable ( $\overline{CEN}$ ) pin to suspend operation
- Synchronous self-timed writes
- Asynchronous output enable ( $\overline{OE}$ )
- Available in Pb-free 100-pin TQFP package, Pb-free and non Pb-free 119-ball BGA package
- Burst capability – linear or interleaved burst order
- “ZZ” sleep mode option

## Functional Description

The CY7C1350G is a 3.3 V, 128K × 36 synchronous-pipelined burst SRAM designed specifically to support unlimited true back-to-back read/write operations without the insertion of wait states. The CY7C1350G is equipped with the advanced No Bus Latency™ (NoBL™) logic required to enable consecutive read/write operations with data being transferred on every clock cycle. This feature dramatically improves the throughput of the SRAM, especially in systems that require frequent write/read transitions.

All synchronous inputs pass through input registers controlled by the rising edge of the clock. All data outputs pass through output registers controlled by the rising edge of the clock. The clock input is qualified by the clock enable ( $\overline{CEN}$ ) signal, which, when deasserted, suspends operation and extends the previous clock cycle. Maximum access delay from the clock rise is 2.8 ns (200-MHz device).

Write operations are controlled by the four byte write select ( $BW_{[A:D]}$ ) and a write enable ( $\overline{WE}$ ) input. All writes are conducted with on-chip synchronous self-timed write circuitry.

Three synchronous chip enables ( $\overline{CE}_1$ ,  $\overline{CE}_2$ ,  $\overline{CE}_3$ ) and an asynchronous output enable ( $\overline{OE}$ ) provide for easy bank selection and output tristate control. In order to avoid bus contention, the output drivers are synchronously tri-stated during the data portion of a write sequence.

For a complete list of related documentation, click [here](#).

## Logic Block Diagram

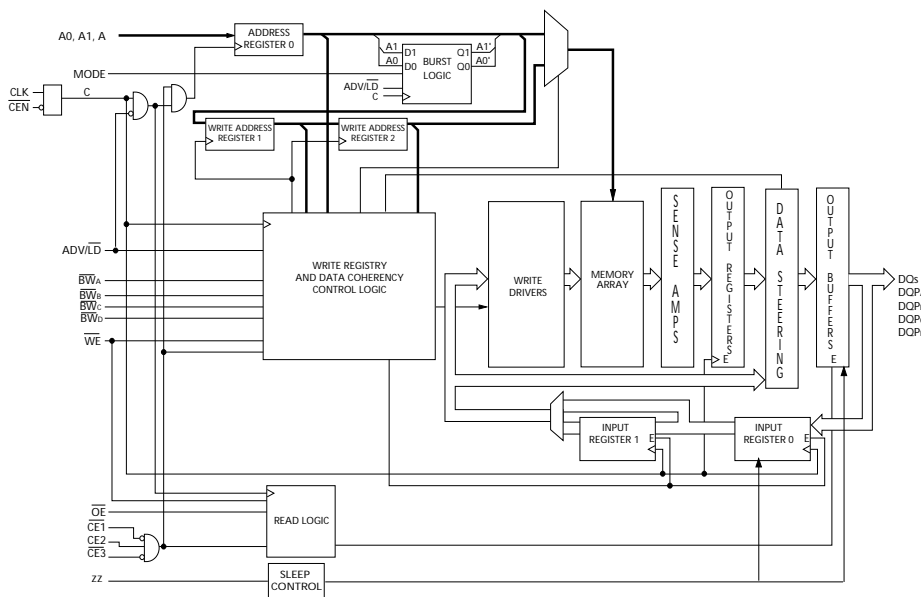

**Errata:** For information on silicon errata, see "Errata" on page 19. Details include trigger conditions, devices affected, and proposed workaround.

## Contents

<b>Selection Guide</b> .....	<b>3</b>	<b>Switching Characteristics</b> .....	<b>12</b>
<b>Pin Configurations</b> .....	<b>3</b>	<b>Switching Waveforms</b> .....	<b>13</b>
<b>Pin Definitions</b> .....	<b>5</b>	<b>Ordering Information</b> .....	<b>15</b>
<b>Functional Overview</b> .....	<b>6</b>	Ordering Code Definitions .....	15
Single Read Accesses .....	6	<b>Package Diagrams</b> .....	<b>16</b>
Burst Read Accesses .....	6	<b>Acronyms</b> .....	<b>18</b>
Single Write Accesses .....	6	<b>Document Conventions</b> .....	<b>18</b>
Burst Write Accesses .....	6	Units of Measure .....	18
Sleep Mode .....	6	<b>Errata</b> .....	<b>19</b>
Interleaved Burst Address Table .....	7	Part Numbers Affected .....	19
Linear Burst Address Table .....	7	Product Status .....	19
ZZ Mode Electrical Characteristics .....	7	Ram9 NoBL ZZ Pin Issues Errata Summary .....	19
<b>Truth Table</b> .....	<b>8</b>	<b>Document History Page</b> .....	<b>20</b>
<b>Partial Truth Table for Read/Write</b> .....	<b>9</b>	<b>Sales, Solutions, and Legal Information</b> .....	<b>22</b>
<b>Maximum Ratings</b> .....	<b>10</b>	Worldwide Sales and Design Support .....	22
<b>Operating Range</b> .....	<b>10</b>	Products .....	22
<b>Electrical Characteristics</b> .....	<b>10</b>	PSoC® Solutions .....	22
<b>Capacitance</b> .....	<b>11</b>	Cypress Developer Community .....	22
<b>Thermal Resistance</b> .....	<b>11</b>	Technical Support .....	22
<b>AC Test Loads and Waveforms</b> .....	<b>11</b>		

Selection Guide

Description	200 MHz	133 MHz	Unit
Maximum access time	2.8	4.0	ns
Maximum operating current	265	225	mA
Maximum CMOS standby current	40	40	mA

Pin Configurations

Figure 1. 100-pin TQFP (14 × 20 × 1.4 mm) pinout [1]

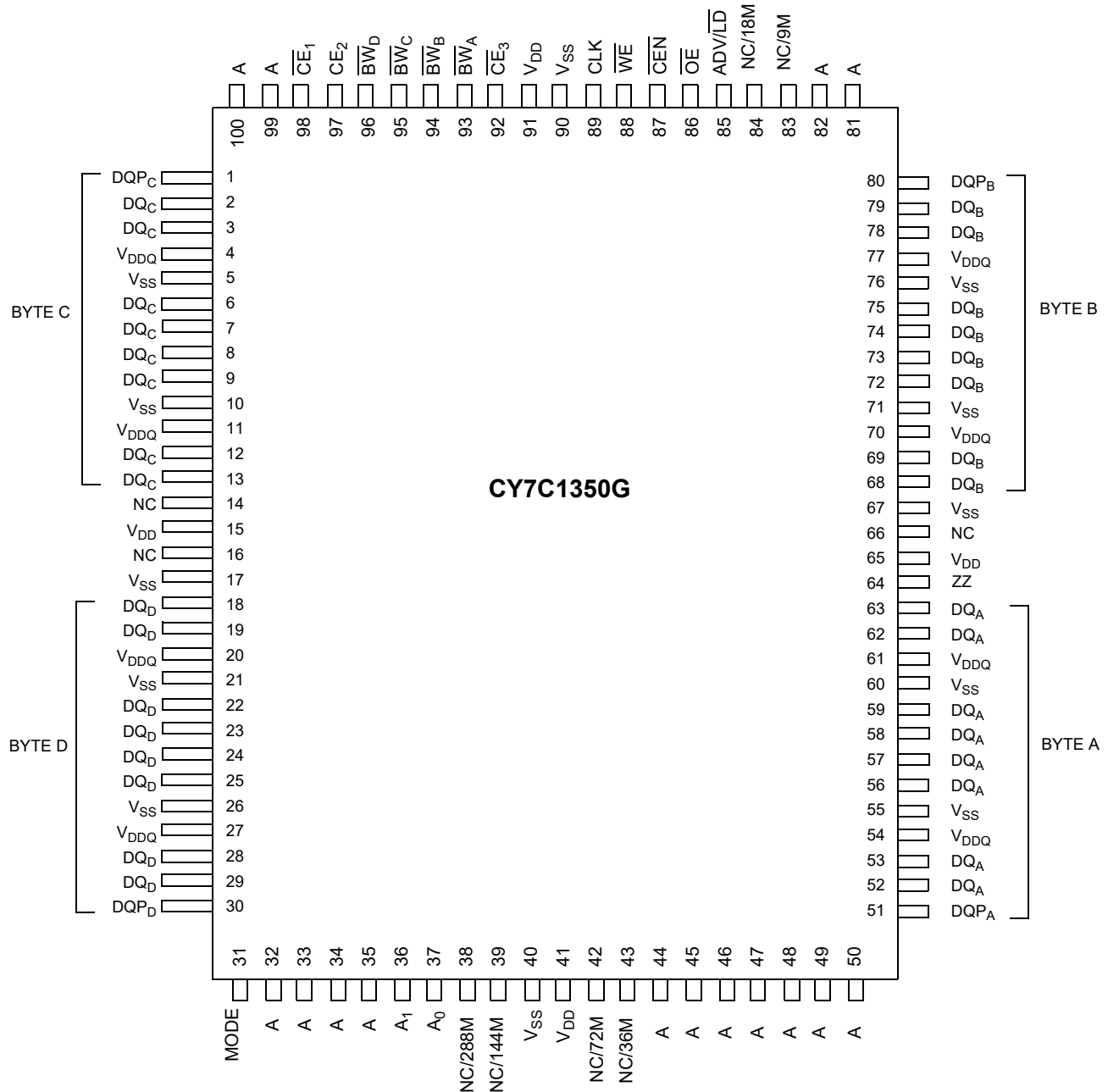

Note

- Errata:** The ZZ pin (Pin 64) needs to be externally connected to ground. For more information, see "Errata" on page 19.

**Pin Configurations** *(continued)*
**Figure 2. 119-Ball BGA (14 × 22 × 2.4 mm) pinout** <sup>[2]</sup>

	<b>1</b>	<b>2</b>	<b>3</b>	<b>4</b>	<b>5</b>	<b>6</b>	<b>7</b>
<b>A</b>	V <sub>DDQ</sub>	A	A	NC/18M	A	A	V <sub>DDQ</sub>
<b>B</b>	NC/576M	CE <sub>2</sub>	A	ADV/LD	A	$\overline{CE}_3$	NC
<b>C</b>	NC/1G	A	A	V <sub>DD</sub>	A	A	NC
<b>D</b>	DQ <sub>C</sub>	DQP <sub>C</sub>	V <sub>SS</sub>	NC	V <sub>SS</sub>	DQP <sub>B</sub>	DQ <sub>B</sub>
<b>E</b>	DQ <sub>C</sub>	DQ <sub>C</sub>	V <sub>SS</sub>	$\overline{CE}_1$	V <sub>SS</sub>	DQ <sub>B</sub>	DQ <sub>B</sub>
<b>F</b>	V <sub>DDQ</sub>	DQ <sub>C</sub>	V <sub>SS</sub>	$\overline{OE}$	V <sub>SS</sub>	DQ <sub>B</sub>	V <sub>DDQ</sub>
<b>G</b>	DQ <sub>C</sub>	DQ <sub>C</sub>	$\overline{BW}_C$	NC/9M	$\overline{BW}_B$	DQ <sub>B</sub>	DQ <sub>B</sub>
<b>H</b>	DQ <sub>C</sub>	DQ <sub>C</sub>	V <sub>SS</sub>	$\overline{WE}$	V <sub>SS</sub>	DQ <sub>B</sub>	DQ <sub>B</sub>
<b>J</b>	V <sub>DDQ</sub>	V <sub>DD</sub>	V <sub>SS</sub>	V <sub>DD</sub>	V <sub>SS</sub>	V <sub>DD</sub>	V <sub>DDQ</sub>
<b>K</b>	DQ <sub>D</sub>	DQ <sub>D</sub>	V <sub>SS</sub>	CLK	V <sub>SS</sub>	DQ <sub>A</sub>	DQ <sub>A</sub>
<b>L</b>	DQ <sub>D</sub>	DQ <sub>D</sub>	$\overline{BW}_D$	NC	$\overline{BW}_A$	DQ <sub>A</sub>	DQ <sub>A</sub>
<b>M</b>	V <sub>DDQ</sub>	DQ <sub>D</sub>	V <sub>SS</sub>	$\overline{CEN}$	V <sub>SS</sub>	DQ <sub>A</sub>	V <sub>DDQ</sub>
<b>N</b>	DQ <sub>D</sub>	DQ <sub>D</sub>	V <sub>SS</sub>	A1	V <sub>SS</sub>	DQ <sub>A</sub>	DQ <sub>A</sub>
<b>P</b>	DQ <sub>D</sub>	DQP <sub>D</sub>	V <sub>SS</sub>	A0	V <sub>SS</sub>	DQP <sub>A</sub>	DQ <sub>A</sub>
<b>R</b>	NC/144M	A	MODE	V <sub>DD</sub>	NC	A	NC/288M
<b>T</b>	NC	NC/72M	A	A	A	NC/36M	ZZ
<b>U</b>	V <sub>DDQ</sub>	NC	NC	NC	NC	NC	V <sub>DDQ</sub>

**Note**

2. **Errata:** The ZZ ball (T7) needs to be externally connected to ground. For more information, see "Errata" on page 19.

## Pin Definitions

Name	I/O	Description
A <sub>0</sub> , A <sub>1</sub> , A	Input-synchronous	<b>Address inputs used to select one of the 128K address locations.</b> Sampled at the rising edge of the CLK. A <sub>[1:0]</sub> are fed to the two-bit burst counter.
BW <sub>[A:D]</sub>	Input-synchronous	<b>Byte write inputs, active LOW.</b> Qualified with $\overline{WE}$ to conduct writes to the SRAM. Sampled on the rising edge of CLK.
$\overline{WE}$	Input-synchronous	<b>Write enable input, active LOW.</b> Sampled on the rising edge of CLK if $\overline{CEN}$ is active LOW. This signal must be asserted LOW to initiate a write sequence.
ADV/ $\overline{LD}$	Input-synchronous	<b>Advance/load input.</b> Used to advance the on-chip address counter or load a new address. When HIGH (and $\overline{CEN}$ is asserted LOW) the internal burst counter is advanced. When LOW, a new address can be loaded into the device for an access. After being deselected, ADV/ $\overline{LD}$ should be driven LOW in order to load a new address.
CLK	Input-clock	<b>Clock input.</b> Used to capture all synchronous inputs to the device. CLK is qualified with $\overline{CEN}$ . CLK is only recognized if $\overline{CEN}$ is active LOW.
$\overline{CE}_1$	Input-synchronous	<b>Chip enable 1 input, active LOW.</b> Sampled on the rising edge of CLK. Used in conjunction with $\overline{CE}_2$ and $\overline{CE}_3$ to select/deselect the device.
$\overline{CE}_2$	Input-synchronous	<b>Chip enable 2 input, active HIGH.</b> Sampled on the rising edge of CLK. Used in conjunction with $\overline{CE}_1$ and $\overline{CE}_3$ to select/deselect the device.
$\overline{CE}_3$	Input-synchronous	<b>Chip enable 3 input, active LOW.</b> Sampled on the rising edge of CLK. Used in conjunction with $\overline{CE}_1$ and $\overline{CE}_2$ to select/deselect the device.
$\overline{OE}$	Input-asynchronous	<b>Output enable, asynchronous input, active LOW.</b> Combined with the synchronous logic block inside the device to control the direction of the I/O pins. When LOW, the I/O pins are allowed to behave as outputs. When deasserted HIGH, I/O pins are tri-stated, and act as input data pins. $\overline{OE}$ is masked during the data portion of a write sequence, during the first clock when emerging from a deselected state, when the device has been deselected.
$\overline{CEN}$	Input-synchronous	<b>Clock enable input, active LOW.</b> When asserted LOW the Clock signal is recognized by the SRAM. When deasserted HIGH the clock signal is masked. Since deasserting $\overline{CEN}$ does not deselect the device, $\overline{CEN}$ can be used to extend the previous cycle when required.
ZZ <sup>[3]</sup>	Input-asynchronous	<b>ZZ "sleep" input.</b> This active HIGH input places the device in a non-time critical "sleep" condition with data integrity preserved. During normal operation, this pin has to be low or left floating. ZZ pin has an internal pull-down.
DQ <sub>s</sub>	I/O-synchronous	<b>Bidirectional data I/O lines.</b> As inputs, they feed into an on-chip data register that is triggered by the rising edge of CLK. As outputs, they deliver the data contained in the memory location specified by the address during the clock rise of the read cycle. The direction of the pins is controlled by $\overline{OE}$ and the internal control logic. When $\overline{OE}$ is asserted LOW, the pins can behave as outputs. When HIGH, DQ <sub>s</sub> and DQP <sub>x</sub> are placed in a tristate condition. The outputs are automatically tri-stated during the data portion of a write sequence, during the first clock when emerging from a deselected state, and when the device is deselected, regardless of the state of $\overline{OE}$ .
DQP <sub>[A:D]</sub>	I/O-synchronous	<b>Bidirectional data parity I/O lines.</b> Functionally, these signals are identical to DQ <sub>s</sub> . During write sequences, DQP <sub>[A:D]</sub> is controlled by BW <sub>[A:D]</sub> correspondingly.
MODE	Input strap pin	<b>Mode input. Selects the burst order of the device.</b> When tied to GND selects linear burst sequence. When tied to V <sub>DD</sub> or left floating selects interleaved burst sequence.
V <sub>DD</sub>	Power supply	<b>Power supply inputs to the core of the device.</b>
V <sub>DDQ</sub>	I/O power supply	<b>Power supply for the I/O circuitry.</b>
V <sub>SS</sub>	Ground	<b>Ground for the device.</b>
NC	–	<b>No Connects.</b> Not internally connected to the die. 9M, 18M, 36M, 72M, 144M and 288M are address expansion pins in this device and will be used as address pins in their respective densities.

**Note**

- Errata:** The ZZ pin needs to be externally connected to ground. For more information, see "Errata" on page 19.

## Functional Overview

The CY7C1350G is a synchronous-pipelined burst SRAM designed specifically to eliminate wait states during write/read transitions. All synchronous inputs pass through input registers controlled by the rising edge of the clock. The clock signal is qualified with the clock enable input signal (CEN). If CEN is HIGH, the clock signal is not recognized and all internal states are maintained. All synchronous operations are qualified with CEN. All data outputs pass through output registers controlled by the rising edge of the clock. Maximum access delay from the clock rise ( $t_{CO}$ ) is 2.8 ns (200 MHz device).

Accesses can be initiated by asserting all three chip enables ( $CE_1$ ,  $CE_2$ ,  $CE_3$ ) active at the rising edge of the clock. If clock enable (CEN) is active LOW and ADV/LD is asserted LOW, the address presented to the device will be latched. The access can either be a read or write operation, depending on the status of the write enable (WE).  $BW_{[A:D]}$  can be used to conduct byte write operations.

Write operations are qualified by the write enable ( $\overline{WE}$ ). All writes are simplified with on-chip synchronous self-timed write circuitry.

Three synchronous chip enables ( $\overline{CE}_1$ ,  $CE_2$ ,  $\overline{CE}_3$ ) and an asynchronous output enable ( $\overline{OE}$ ) simplify depth expansion. All operations (reads, writes, and deselections) are pipelined. ADV/LD should be driven LOW once the device has been deselected in order to load a new address for the next operation.

### Single Read Accesses

A read access is initiated when the following conditions are satisfied at clock rise: (1) CEN is asserted LOW, (2)  $\overline{CE}_1$ ,  $CE_2$ , and  $\overline{CE}_3$  are all asserted active, (3) the write enable input signal WE is deasserted HIGH, and (4) ADV/LD is asserted LOW. The address presented to the address inputs is latched into the address register and presented to the memory core and control logic. The control logic determines that a read access is in progress and allows the requested data to propagate to the input of the output register. At the rising edge of the next clock the requested data is allowed to propagate through the output register and onto the data bus, provided  $\overline{OE}$  is active LOW. After the first clock of the read access the output buffers are controlled by  $\overline{OE}$  and the internal control logic.  $\overline{OE}$  must be driven LOW in order for the device to drive out the requested data. During the second clock, a subsequent operation (read/write/deselect) can be initiated. Deselecting the device is also pipelined. Therefore, when the SRAM is deselected at clock rise by one of the chip enable signals, its output will tristate following the next clock rise.

### Burst Read Accesses

The CY7C1350G has an on-chip burst counter that allows the user the ability to supply a single address and conduct up to four reads without reasserting the address inputs. ADV/LD must be driven LOW in order to load a new address into the SRAM, as described in [Single Read Accesses](#). The sequence of the burst counter is determined by the MODE input signal. A LOW input on MODE selects a linear burst mode, a HIGH selects an interleaved burst sequence. Both burst counters use A0 and A1 in the burst sequence, and will wrap around when incremented sufficiently. A HIGH input on ADV/LD will increment the internal burst counter regardless of the state of chip enables inputs or WE. WE is latched at the beginning of a burst cycle. Therefore, the type

of access (read or write) is maintained throughout the burst sequence.

### Single Write Accesses

Write accesses are initiated when the following conditions are satisfied at clock rise: (1) CEN is asserted LOW, (2)  $\overline{CE}_1$ ,  $CE_2$ , and  $\overline{CE}_3$  are all asserted active, and (3) the write signal WE is asserted LOW. The address presented to the address inputs is loaded into the address register. The write signals are latched into the control logic block.

On the subsequent clock rise the data lines are automatically tri-stated regardless of the state of the  $\overline{OE}$  input signal. This allows the external logic to present the data on DQs and  $DQP_{[A:D]}$ . In addition, the address for the subsequent access (read/write/deselect) is latched into the address register (provided the appropriate control signals are asserted).

On the next clock rise the data presented to DQs and  $DQP_{[A:D]}$  (or a subset for byte write operations, see Write Cycle Description table for details) inputs is latched into the device and the write is complete.

The data written during the write operation is controlled by  $BW_{[A:D]}$  signals. The CY7C1350G provides byte write capability that is described in the Write Cycle Description table. Asserting the write enable input ( $\overline{WE}$ ) with the selected byte write select ( $BW_{[A:D]}$ ) input will selectively write to only the desired bytes. Bytes not selected during a byte write operation will remain unaltered. A synchronous self-timed write mechanism has been provided to simplify the write operations. Byte write capability has been included in order to greatly simplify read/modify/write sequences, which can be reduced to simple byte write operations.

Because the CY7C1350G is a common I/O device, data should not be driven into the device while the outputs are active. The output enable ( $\overline{OE}$ ) can be deasserted HIGH before presenting data to the DQs and  $DQP_{[A:D]}$  inputs. Doing so will tristate the output drivers. As a safety precaution, DQs and  $DQP_{[A:D]}$  are automatically tri-stated during the data portion of a write cycle, regardless of the state of  $\overline{OE}$ .

### Burst Write Accesses

The CY7C1350G has an on-chip burst counter that allows the user the ability to supply a single address and conduct up to four write operations without reasserting the address inputs. ADV/LD must be driven LOW in order to load the initial address, as described in [Single Write Accesses](#). When ADV/LD is driven HIGH on the subsequent clock rise, the chip enables ( $\overline{CE}_1$ ,  $CE_2$ , and  $\overline{CE}_3$ ) and WE inputs are ignored and the burst counter is incremented. The correct  $BW_{[A:D]}$  inputs must be driven in each cycle of the burst write in order to write the correct bytes of data.

### Sleep Mode

The ZZ input pin is an asynchronous input. Asserting ZZ places the SRAM in a power conservation "sleep" mode. Two clock cycles are required to enter into or exit from this "sleep" mode. While in this mode, data integrity is guaranteed. Accesses pending when entering the "sleep" mode are not considered valid nor is the completion of the operation guaranteed. The device must be deselected prior to entering the "sleep" mode.  $CE_1$ ,  $CE_2$ , and  $CE_3$ , must remain inactive for the duration of  $t_{ZZREC}$  after the ZZ input returns LOW.

**Interleaved Burst Address Table**

(MODE = Floating or  $V_{DD}$ )

First Address A1:A0	Second Address A1:A0	Third Address A1:A0	Fourth Address A1:A0
00	01	10	11
01	00	11	10
10	11	00	01
11	10	01	00

**Linear Burst Address Table**

(MODE = GND)

First Address A1:A0	Second Address A1:A0	Third Address A1:A0	Fourth Address A1:A0
00	01	10	11
01	10	11	00
10	11	00	01
11	00	01	10

**ZZ Mode Electrical Characteristics**

Parameter	Description	Test Conditions	Min	Max	Unit
$I_{DDZZ}$	Snooze mode standby current	$ZZ \geq V_{DD} - 0.2 V$	–	40	mA
$t_{ZZS}$	Device operation to ZZ	$ZZ \geq V_{DD} - 0.2 V$	–	$2t_{CYC}$	ns
$t_{ZZREC}$	ZZ recovery time	$ZZ \leq 0.2 V$	$2t_{CYC}$	–	ns
$t_{ZZI}$	ZZ active to snooze current	This parameter is sampled	–	$2t_{CYC}$	ns
$t_{RZZI}$	ZZ inactive to exit snooze current	This parameter is sampled	0	–	ns

## Truth Table

The Truth Table for part CY7C1350G is as follows. [4, 5, 6, 7, 8, 9, 10]

Operation	Address Used	$\overline{CE}$	ZZ	ADV/LD	$\overline{WE}$	$\overline{BW}_x$	$\overline{OE}$	$\overline{CEN}$	CLK	DQ
Deselect cycle	None	H	L	L	X	X	X	L	L-H	Tristate
Continue deselect cycle	None	X	L	H	X	X	X	L	L-H	Tristate
Read cycle (begin burst)	External	L	L	L	H	X	L	L	L-H	Data out (Q)
Read cycle (continue burst)	Next	X	L	H	X	X	L	L	L-H	Data out (Q)
NOP/dummy read (begin burst)	External	L	L	L	H	X	H	L	L-H	Tristate
Dummy read (continue burst)	Next	X	L	H	X	X	H	L	L-H	Tristate
Write cycle (begin burst)	External	L	L	L	L	L	X	L	L-H	Data in (D)
Write cycle (continue burst)	Next	X	L	H	X	L	X	L	L-H	Data in (D)
NOP/WRITE ABORT (begin burst)	None	L	L	L	L	H	X	L	L-H	Tristate
WRITE ABORT (continue burst)	Next	X	L	H	X	H	X	L	L-H	Tristate
IGNORE CLOCK EDGE (stall)	Current	X	L	X	X	X	X	H	L-H	-
SNOOZE MODE	None	X	H	X	X	X	X	X	X	Tristate

### Notes

4. X = "Don't Care." H = Logic HIGH, L = Logic LOW.  $\overline{CE}$  stands for all chip enables active.  $\overline{BW}_x = L$  signifies at least one byte write select is active,  $\overline{BW}_x = \text{valid}$  signifies that the desired byte write selects are asserted, see Write Cycle Description table for details.
5. Write is defined by  $\overline{BW}_x$  and  $\overline{WE}$ . See Write Cycle Descriptions table.
6. When a write cycle is detected, all DQs are tri-stated, even during byte writes.
7. The DQ and DQP pins are controlled by the current cycle and the  $\overline{OE}$  signal.  $\overline{OE}$  is asynchronous and is not sampled with the clock.
8.  $\overline{CEN} = H$ , inserts wait states.
9. Device will power-up deselected and the DQs in a tristate condition, regardless of  $\overline{OE}$ .
10.  $\overline{OE}$  is asynchronous and is not sampled with the clock rise. It is masked internally during write cycles. During a read cycle DQs and  $DQP_{[A:D]}$  = tristate when  $\overline{OE}$  is inactive or when the device is deselected, and DQs and  $DQP_{[A:D]}$  = data when  $\overline{OE}$  is active.

## Partial Truth Table for Read/Write

The Partial Truth Table for read or write for part CY7C1350G is as follows. [11, 12, 13]

Function	$\overline{WE}$	$\overline{BW}_D$	$\overline{BW}_C$	$\overline{BW}_B$	$\overline{BW}_A$
Read	H	X	X	X	X
Write – no bytes written	L	H	H	H	H
Write byte A – (DQ <sub>A</sub> and DQP <sub>A</sub> )	L	H	H	H	L
Write byte B – (DQ <sub>B</sub> and DQP <sub>B</sub> )	L	H	H	L	H
Write bytes A, B	L	H	H	L	L
Write byte C – (DQ <sub>C</sub> and DQP <sub>C</sub> )	L	H	L	H	H
Write bytes C, A	L	H	L	H	L
Write bytes C, B	L	H	L	L	H
Write bytes C, B, A	L	H	L	L	L
Write byte D – (DQ <sub>D</sub> and DQP <sub>D</sub> )	L	L	H	H	H
Write bytes D, A	L	L	H	H	L
Write bytes D, B	L	L	H	L	H
Write bytes D, B, A	L	L	H	L	L
Write bytes D, C	L	L	L	H	H
Write bytes D, C, A	L	L	L	H	L
Write bytes D, C, B	L	L	L	L	H
Write all bytes	L	L	L	L	L

### Notes

11. X = "Don't Care." H = Logic HIGH, L = Logic LOW.  $\overline{CE}$  stands for all chip enables active.  $\overline{BW}_x = L$  signifies at least one byte write select is active,  $\overline{BW}_x = \text{valid}$  signifies that the desired byte write selects are asserted, see Write Cycle Description table for details.

12. Write is defined by  $\overline{BW}_x$ , and  $\overline{WE}$ . See Write Cycle Descriptions table.

13. Table only lists a partial listing of the byte write combinations. Any combination of  $\overline{BW}_x$  is valid. Appropriate write will be done on which byte write is active.

## Maximum Ratings

Exceeding maximum ratings may shorten the useful life of the device. User guidelines are not tested.

Storage temperature .....	-65 °C to +150 °C
Ambient temperature with power applied .....	-55 °C to +125 °C
Supply voltage on V <sub>DD</sub> relative to GND .....	-0.5 V to +4.6 V
Supply voltage on V <sub>DDQ</sub> relative to GND .....	-0.5 V to +V <sub>DD</sub>
DC voltage applied to outputs in tristate .....	-0.5 V to V <sub>DDQ</sub> + 0.5 V

DC input voltage .....	-0.5 V to V <sub>DD</sub> + 0.5 V
Current into outputs (LOW) .....	20 mA
Static discharge voltage (per MIL-STD-883, method 3015) .....	> 2001 V
Latch-up current .....	> 200 mA

## Operating Range

Range	Ambient Temperature (T <sub>A</sub> )	V <sub>DD</sub>	V <sub>DDQ</sub>
Commercial	0 °C to +70 °C	3.3 V – 5% / + 10%	2.5 V – 5% to V <sub>DD</sub>
Industrial	-40 °C to +85 °C		

## Electrical Characteristics

Over the Operating Range

Parameter <sup>[14, 15]</sup>	Description	Test Conditions	Min	Max	Unit	
V <sub>DD</sub>	Power supply voltage		3.135	3.6	V	
V <sub>DDQ</sub>	I/O supply voltage		2.375	V <sub>DD</sub>	V	
V <sub>OH</sub>	Output HIGH voltage	for 3.3 V I/O, I <sub>OH</sub> = -4.0 mA	2.4	-	V	
		for 2.5 V I/O, I <sub>OH</sub> = -1.0 mA	2.0	-	V	
V <sub>OL</sub>	Output LOW voltage	for 3.3 V I/O, I <sub>OL</sub> = 8.0 mA	-	0.4	V	
		for 2.5 V I/O, I <sub>OL</sub> = 1.0 mA	-	0.4	V	
V <sub>IH</sub>	Input HIGH voltage <sup>[14]</sup>	V <sub>DDQ</sub> = 3.3 V	2.0	V <sub>DD</sub> + 0.3 V	V	
		V <sub>DDQ</sub> = 2.5 V	1.7	V <sub>DD</sub> + 0.3 V	V	
V <sub>IL</sub>	Input LOW voltage <sup>[14]</sup>	V <sub>DDQ</sub> = 3.3 V	-0.3	0.8	V	
		V <sub>DDQ</sub> = 2.5 V	-0.3	0.7	V	
I <sub>X</sub>	Input leakage current except ZZ and MODE	GND ≤ V <sub>I</sub> ≤ V <sub>DDQ</sub>	-5	5	μA	
	Input current of MODE	Input = V <sub>SS</sub>	-30	-	μA	
		Input = V <sub>DD</sub>	-	5	μA	
	Input current of ZZ	Input = V <sub>SS</sub>	-5	-	μA	
Input = V <sub>DD</sub>		-	30	μA		
I <sub>OZ</sub>	Output leakage current	GND ≤ V <sub>I</sub> ≤ V <sub>DDQ</sub> , output disabled	-5	5	μA	
I <sub>DD</sub>	V <sub>DD</sub> operating supply current	V <sub>DD</sub> = Max., I <sub>OUT</sub> = 0 mA, f = f <sub>MAX</sub> = 1/t <sub>CYC</sub>	5-ns cycle, 200 MHz	-	265	mA
			7.5-ns cycle, 133 MHz	-	225	mA
I <sub>SB1</sub>	Automatic CE power-down current – TTL inputs	V <sub>DD</sub> = Max, device deselected, V <sub>IN</sub> ≥ V <sub>IH</sub> or V <sub>IN</sub> ≤ V <sub>IL</sub> , f = f <sub>MAX</sub> = 1/t <sub>CYC</sub>	5-ns cycle, 200 MHz	-	110	mA
			7.5-ns cycle, 133 MHz	-	90	mA
I <sub>SB2</sub>	Automatic CE power-down current – CMOS inputs	V <sub>DD</sub> = Max, device deselected, V <sub>IN</sub> ≤ 0.3 V or V <sub>IN</sub> ≥ V <sub>DDQ</sub> - 0.3 V, f = 0	All speeds	-	40	mA

### Notes

14. Overshoot: V<sub>IH(AC)</sub> < V<sub>DD</sub> + 1.5 V (Pulse width less than t<sub>CYC</sub>/2), undershoot: V<sub>IL(AC)</sub> > -2 V (Pulse width less than t<sub>CYC</sub>/2).  
 15. T<sub>Power-up</sub>: Assumes a linear ramp from 0 V to V<sub>DD(min)</sub> within 200 ms. During this time V<sub>IH</sub> < V<sub>DD</sub> and V<sub>DDQ</sub> ≤ V<sub>DD</sub>.

**Electrical Characteristics** *(continued)*

Over the Operating Range

Parameter <sup>[14, 15]</sup>	Description	Test Conditions	Min	Max	Unit	
$I_{SB3}$	Automatic CE power-down current – CMOS inputs	$V_{DD} = \text{Max}$ , device deselected, $V_{IN} \leq 0.3 \text{ V}$ or $V_{IN} \geq V_{DDQ} - 0.3 \text{ V}$ , $f = f_{MAX} = 1/t_{CYC}$	5-ns cycle, 200 MHz	–	95	mA
			7.5-ns cycle, 133 MHz	–	75	mA
$I_{SB4}$	Automatic CE power-down current – TTL inputs	$V_{DD} = \text{Max}$ , device deselected, $V_{IN} \geq V_{IH}$ or $V_{IN} \leq V_{IL}$ , $f = 0$	All speeds	–	45	mA

**Capacitance**

Parameter <sup>[16]</sup>	Description	Test Conditions	100-pin TQFP Max	119-ball BGA Max	Unit
$C_{IN}$	Input capacitance	$T_A = 25 \text{ }^\circ\text{C}$ , $f = 1 \text{ MHz}$ , $V_{DD} = 3.3 \text{ V}$ , $V_{DDQ} = 3.3 \text{ V}$	5	5	pF
$C_{CLK}$	Clock input capacitance		5	5	pF
$C_{I/O}$	Input/Output capacitance		5	7	pF

**Thermal Resistance**

Parameter <sup>[16]</sup>	Description	Test Conditions	100-pin TQFP Package	119-ball BGA Package	Unit
$\Theta_{JA}$	Thermal resistance (junction to ambient)	Test conditions follow standard test methods and procedures for measuring thermal impedance, per EIA/JESD51.	30.32	34.1	$^\circ\text{C/W}$
$\Theta_{JC}$	Thermal resistance (junction to case)		6.85	14.0	$^\circ\text{C/W}$

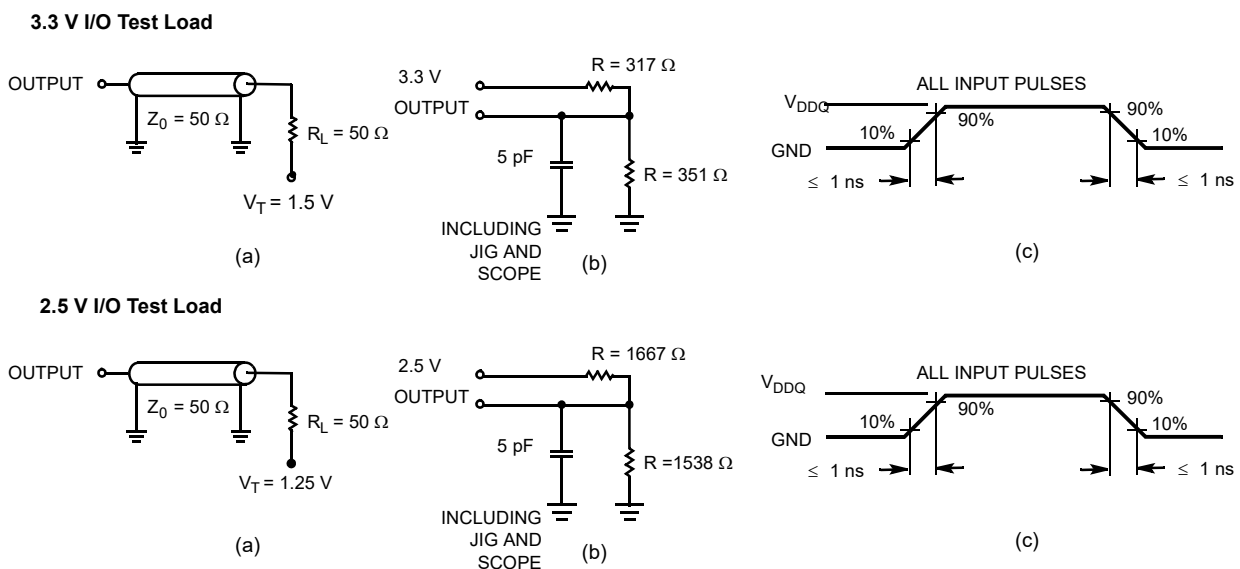
**AC Test Loads and Waveforms**
**Figure 3. AC Test Loads and Waveforms**

**Note**

16. Tested initially and after any design or process changes that may affect these parameters.

## Switching Characteristics

Over the Operating Range

Parameter <sup>[17, 18]</sup>	Description	-200		-133		Unit
		Min	Max	Min	Max	
t <sub>POWER</sub>	V <sub>DD</sub> (typical) to the first access <sup>[19]</sup>	1	–	1	–	ms
<b>Clock</b>						
t <sub>CYC</sub>	Clock cycle time	5.0	–	7.5	–	ns
t <sub>CH</sub>	Clock HIGH	2.0	–	3.0	–	ns
t <sub>CL</sub>	Clock LOW	2.0	–	3.0	–	ns
<b>Output Times</b>						
t <sub>CO</sub>	Data output valid after CLK rise	–	2.8	–	4.0	ns
t <sub>DOH</sub>	Data output hold after CLK rise	1.0	–	1.5	–	ns
t <sub>CLZ</sub>	Clock to low Z <sup>[20, 21, 22]</sup>	0	–	0	–	ns
t <sub>CHZ</sub>	Clock to high Z <sup>[20, 21, 22]</sup>	–	2.8	–	4.0	ns
t <sub>OEV</sub>	$\overline{\text{OE}}$ LOW to output valid	–	2.8	–	4.0	ns
t <sub>OELZ</sub>	$\overline{\text{OE}}$ LOW to output low Z <sup>[20, 21, 22]</sup>	0	–	0	–	ns
t <sub>OEHZ</sub>	$\overline{\text{OE}}$ HIGH to output high Z <sup>[20, 21, 22]</sup>	–	2.8	–	4.0	ns
<b>Setup Times</b>						
t <sub>AS</sub>	Address setup before CLK rise	1.2	–	1.5	–	ns
t <sub>ALS</sub>	ADV/LD setup before CLK rise	1.2	–	1.5	–	ns
t <sub>WES</sub>	$\overline{\text{GW}}$ , $\overline{\text{BW}}_X$ setup before CLK rise	1.2	–	1.5	–	ns
t <sub>CENS</sub>	$\overline{\text{CEN}}$ setup before CLK rise	1.2	–	1.5	–	ns
t <sub>DS</sub>	Data input setup before CLK rise	1.2	–	1.5	–	ns
t <sub>CES</sub>	Chip enable setup before CLK rise	1.2	–	1.5	–	ns
<b>Hold Times</b>						
t <sub>AH</sub>	Address hold after CLK rise	0.5	–	0.5	–	ns
t <sub>ALH</sub>	ADV/LD hold after CLK rise	0.5	–	0.5	–	ns
t <sub>WEH</sub>	$\overline{\text{GW}}$ , $\overline{\text{BW}}_X$ hold after CLK rise	0.5	–	0.5	–	ns
t <sub>CENH</sub>	$\overline{\text{CEN}}$ hold after CLK rise	0.5	–	0.5	–	ns
t <sub>DH</sub>	Data input hold after CLK rise	0.5	–	0.5	–	ns
t <sub>CEH</sub>	Chip enable hold after CLK rise	0.5	–	0.5	–	ns

### Notes

17. Timing reference level is 1.5 V when V<sub>DDQ</sub> = 3.3 V and is 1.25 V when V<sub>DDQ</sub> = 2.5 V.

18. Test conditions shown in (a) of [Figure 3 on page 11](#) unless otherwise noted.

19. This part has a voltage regulator internally; t<sub>POWER</sub> is the time that the power needs to be supplied above V<sub>DD(minimum)</sub> initially before a Read or Write operation can be initiated.

20. t<sub>CHZ</sub>, t<sub>CLZ</sub>, t<sub>OELZ</sub>, and t<sub>OEHZ</sub> are specified with AC test conditions shown in part (b) of [Figure 3 on page 11](#). Transition is measured ±200 mV from steady-state voltage.

21. At any given voltage and temperature, t<sub>OEHZ</sub> is less than t<sub>OELZ</sub> and t<sub>CHZ</sub> is less than t<sub>CLZ</sub> to eliminate bus contention between SRAMs when sharing the same data bus. These specifications do not imply a bus contention condition, but reflect parameters guaranteed over worst case user conditions. Device is designed to achieve tristate prior to low Z under the same system conditions.

22. This parameter is sampled and not 100% tested.

### Switching Waveforms

Figure 4. Read/Write Timing [23, 24, 25]

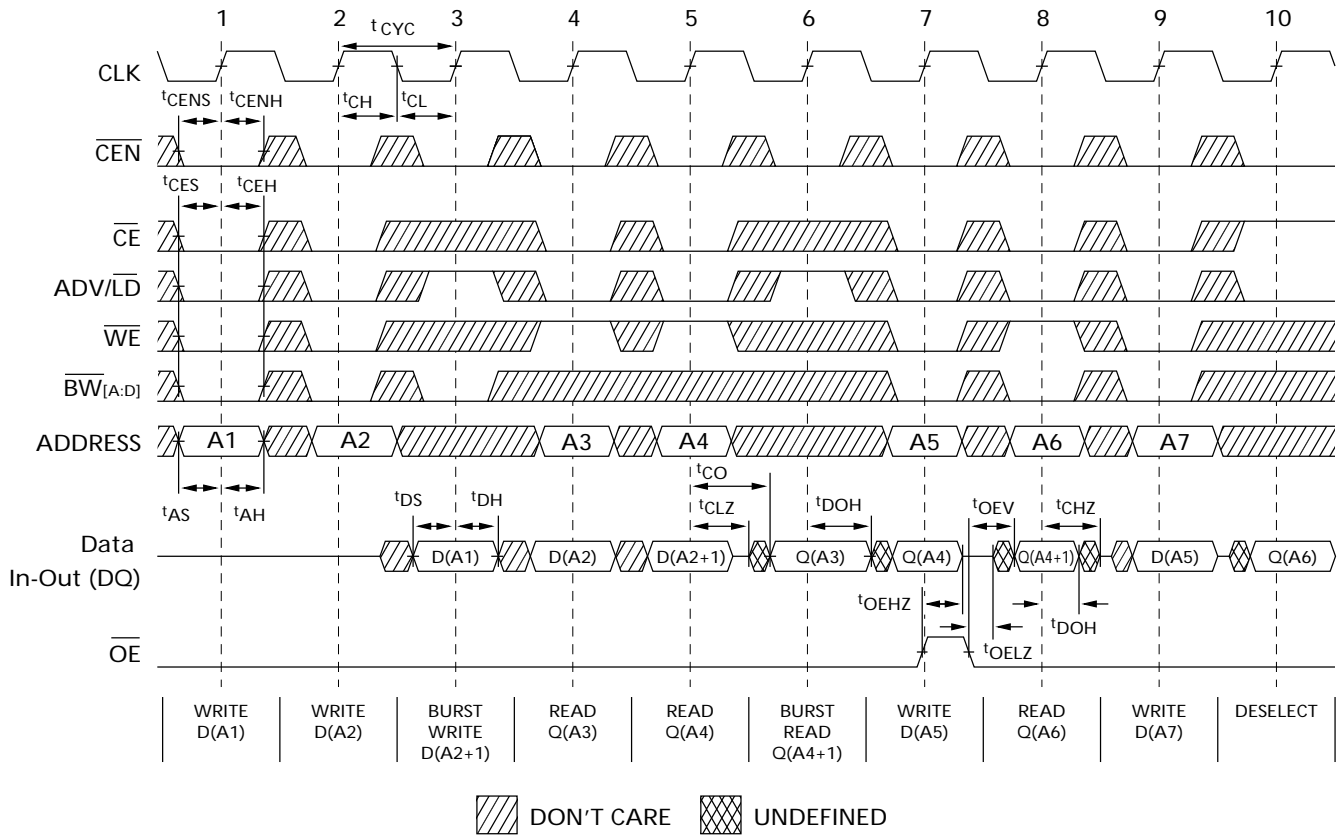

**Notes**

- 23. For this waveform ZZ is tied LOW.
- 24. When  $\overline{CE}$  is LOW,  $\overline{CE}_1$  is LOW,  $CE_2$  is HIGH and  $\overline{CE}_3$  is LOW. When  $\overline{CE}$  is HIGH,  $\overline{CE}_1$  is HIGH or  $CE_2$  is LOW or  $\overline{CE}_3$  is HIGH.
- 25. Order of the burst sequence is determined by the status of the MODE (0 = Linear, 1 = Interleaved). Burst operations are optional.

Switching Waveforms (continued)

Figure 5. NOP, STALL, and DESELECT Cycles [26, 27, 28]

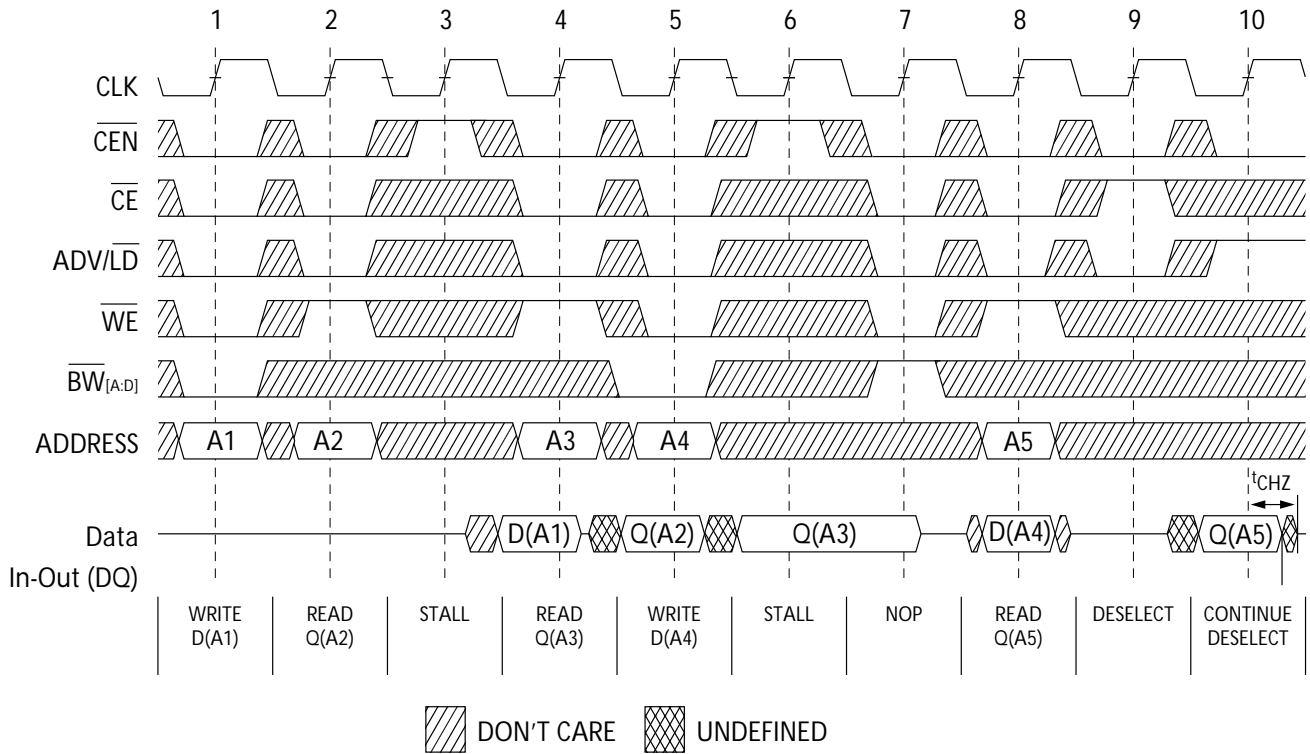
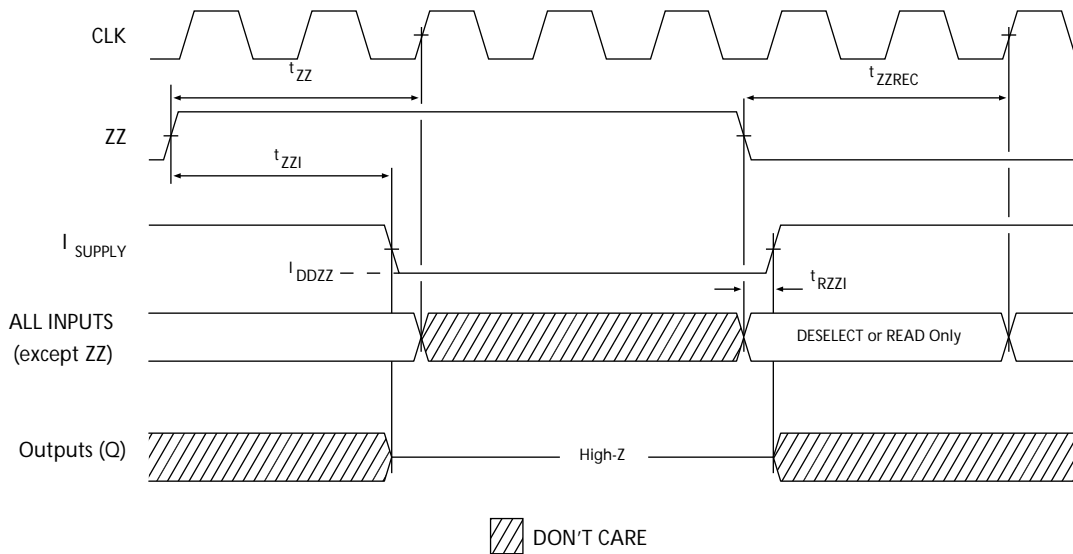

Figure 6. ZZ Mode Timing [29, 30]



Notes

- 26. For this waveform ZZ is tied LOW.
- 27. When  $\overline{CE}$  is LOW,  $\overline{CE}_1$  is LOW,  $\overline{CE}_2$  is HIGH and  $\overline{CE}_3$  is LOW. When  $\overline{CE}$  is HIGH,  $\overline{CE}_1$  is HIGH or  $\overline{CE}_2$  is LOW or  $\overline{CE}_3$  is HIGH.
- 28. The IGNORE CLOCK EDGE or STALL cycle (Clock 3) illustrates  $\overline{CEN}$  being used to create a pause. A write is not performed during this cycle.
- 29. Device must be deselected when entering ZZ mode. See cycle description table for all possible signal conditions to deselect the device.
- 30. DQs are in high Z when exiting ZZ sleep mode.

## Ordering Information

The following table contains only the list of parts that are currently available. If you do not see what you are looking for, contact your local sales representative. For more information, visit the Cypress website at [www.cypress.com](http://www.cypress.com) and refer to the product summary page at <http://www.cypress.com/products>.

Cypress maintains a worldwide network of offices, solution centers, manufacturer's representatives and distributors. To find the office closest to you, visit us at <http://www.cypress.com/go/datasheet/offices>.

Speed (MHz)	Ordering Code	Package Diagram	Package Type	Operating Range
133	CY7C1350G-133AXC	51-85050	100-pin TQFP (14 × 20 × 1.4 mm) Pb-free	Commercial
	CY7C1350G-133AXI	51-85050	100-pin TQFP (14 × 20 × 1.4 mm) Pb-free	Industrial
200	CY7C1350G-200AXC	51-85050	100-pin TQFP (14 × 20 × 1.4 mm) Pb-free	Commercial

## Ordering Code Definitions

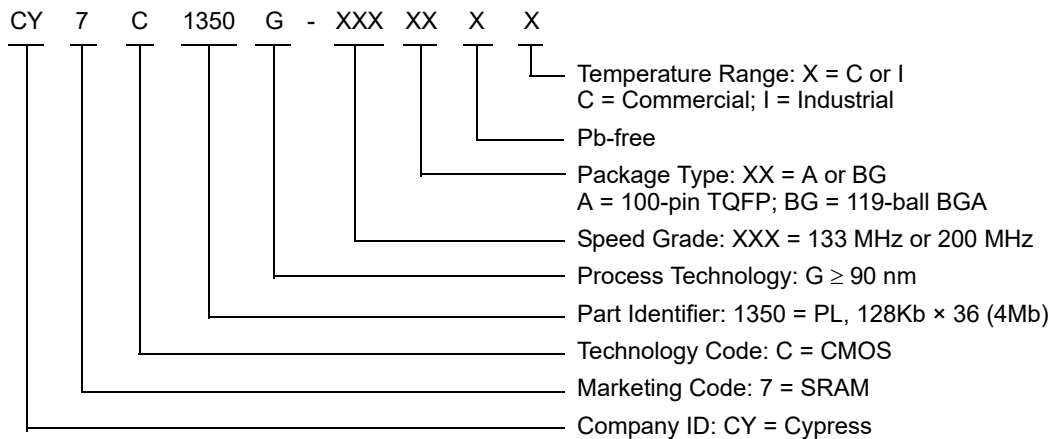

Package Diagrams

Figure 7. 100-pin TQFP (16 × 22 × 1.6 mm) Package Outline, 51-85050

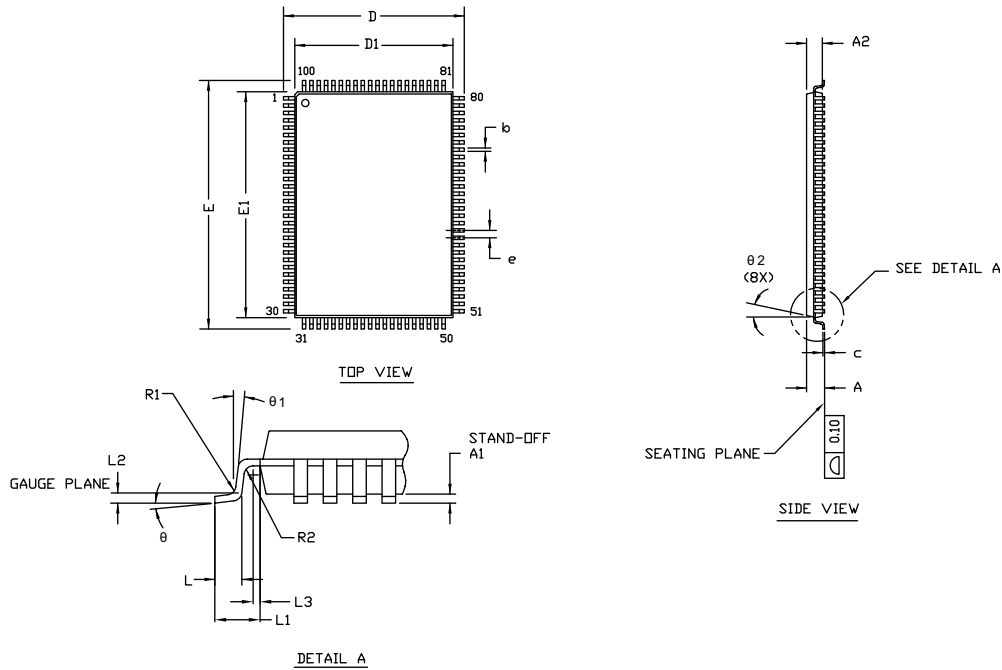

SYMBOL	DIMENSIONS		
	MIN.	NOM.	MAX.
A	—	—	1.60
A1	0.05	—	0.15
A2	1.35	1.40	1.45
D	15.80	16.00	16.20
D1	13.90	14.00	14.10
E	21.80	22.00	22.20
E1	19.90	20.00	20.10
R1	0.08	—	0.20
R2	0.08	—	0.20
theta	0°	—	7°
theta 1	0°	—	—
theta 2	11°	12°	13°
c	—	—	0.20
b	0.22	0.30	0.38
L	0.45	0.60	0.75
L1	1.00 REF		
L2	0.25 BSC		
L3	0.20	—	—
e	0.65 TYP		

NOTE:

1. ALL DIMENSIONS ARE IN MILLIMETERS.
2. BODY LENGTH DIMENSION DOES NOT INCLUDE MOLD PROTRUSION/END FLASH. MOLD PROTRUSION/END FLASH SHALL NOT EXCEED 0.0098 in (0.25 mm) PER SIDE. BODY LENGTH DIMENSIONS ARE MAX PLASTIC BODY SIZE INCLUDING MOLD MISMATCH.
3. JEDEC SPECIFICATION NO. REF: MS-026.

51-85050 \*G

Package Diagrams

Figure 8. 119-ball BGA (14 × 22 × 2.4 mm) Package Outline, 51-85115

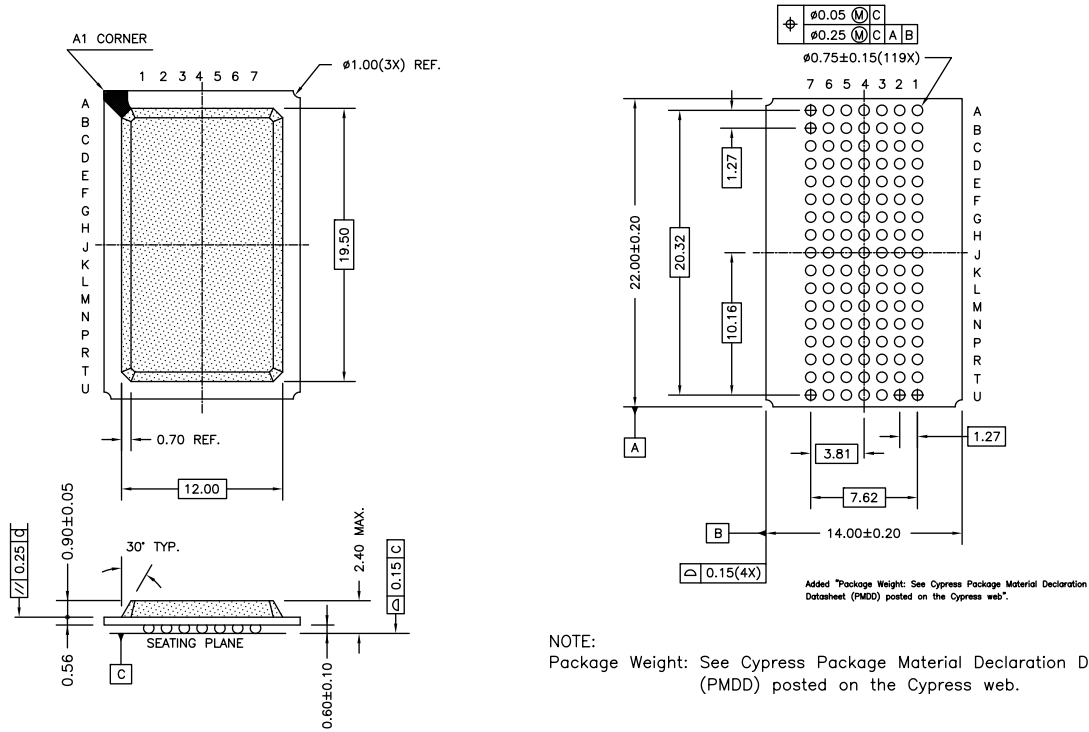

NOTE:  
Package Weight: See Cypress Package Material Declaration Datasheet (PMDD) posted on the Cypress web.

51-85115 \*D

## Acronyms

Acronym	Description
BGA	Ball Grid Array
$\overline{CE}$	Chip Enable
CEN	Clock Enable
CMOS	Complementary Metal Oxide Semiconductor
EIA	Electronic Industries Alliance
I/O	Input/Output
JEDEC	Joint Electron Devices Engineering Council
NoBL	No Bus Latency
$\overline{OE}$	Output Enable
SRAM	Static Random Access Memory
TQFP	Thin Quad Flat Pack
TTL	Transistor-Transistor Logic
$\overline{WE}$	Write Enable

## Document Conventions

### Units of Measure

Symbol	Unit of Measure
°C	degree Celsius
MHz	megahertz
μA	microampere
mA	milliampere
mm	millimeter
ms	millisecond
mV	millivolt
nm	nanometer
ns	nanosecond
Ω	ohm
%	percent
pF	picofarad
V	volt
W	watt

## Errata

This section describes the Ram9 NoBL ZZ pin issue. Details include trigger conditions, the devices affected, proposed workaround and silicon revision applicability. Please contact your local Cypress sales representative if you have further questions.

### Part Numbers Affected

Density & Revision	Package Type	Operating Range
4Mb-Ram9 NoBL™ SRAMs: CY7C135*G	100-pin TQFP	Commercial/ Industrial
	119-ball BGA	Commercial

### Product Status

All of the devices in the Ram9 4Mb NoBL family are qualified and available in production quantities.

### Ram9 NoBL ZZ Pin Issues Errata Summary

The following table defines the errata applicable to available Ram9 4Mb NoBL family devices.

Item	Issues	Description	Device	Fix Status
1.	ZZ Pin	When asserted HIGH, the ZZ pin places device in a “sleep” condition with data integrity preserved. The ZZ pin currently does not have an internal pull-down resistor and hence cannot be left floating externally by the user during normal mode of operation.	4M-Ram9 (90 nm)	For the 4M Ram9 (90 nm) devices, there is no plan to fix this issue.

#### 1. ZZ Pin Issue

##### ■ PROBLEM DEFINITION

The problem occurs only when the device is operated in the normal mode with ZZ pin left floating. The ZZ pin on the SRAM device does not have an internal pull-down resistor. Switching noise in the system may cause the SRAM to recognize a HIGH on the ZZ input, which may cause the SRAM to enter sleep mode. This could result in incorrect or undesirable operation of the SRAM.

##### ■ TRIGGER CONDITIONS

Device operated with ZZ pin left floating.

##### ■ SCOPE OF IMPACT

When the ZZ pin is left floating, the device delivers incorrect data.

##### ■ WORKAROUND

Tie the ZZ pin externally to ground.

##### ■ FIX STATUS

For the 4M Ram9 (90 nm) devices, there is no plan to fix this issue.

**Document History Page**

Document Title: CY7C1350G, 4-Mbit (128K × 36) Pipelined SRAM with NoBL™ Architecture				
Document Number: 38-05524				
Rev.	ECN No.	Orig. of Change	Submission Date	Description of Change
**	224380	RKF	05/17/2004	New data sheet.
*A	276690	VBL	10/14/2004	Updated <a href="#">Ordering Information</a> (Updated part numbers; added comment of BGA Pb-free package availability below the table).
*B	332895	SYT	03/14/2005	Changed status from Preliminary to Final. Updated <a href="#">Features</a> (Removed 225 MHz and 100 MHz frequencies related information). Updated <a href="#">Selection Guide</a> (Removed 225 MHz and 100 MHz frequencies related information). Updated <a href="#">Pin Configurations</a> (Modified Address Expansion balls in the pinouts for 119-ball BGA Package as per JEDEC standards). Updated <a href="#">Electrical Characteristics</a> (Updated test conditions for $V_{OL}$ and $V_{OH}$ parameters, removed 225 MHz and 100 MHz frequencies related information). Updated <a href="#">Thermal Resistance</a> (Replaced TBD's for $\Theta_{JA}$ and $\Theta_{JC}$ to their respective values). Updated <a href="#">Switching Characteristics</a> (Removed 225 MHz and 100 MHz frequencies related information). Updated <a href="#">Ordering Information</a> (Updated part numbers (By removing Shaded Parts); changed the package name for 100-pin TQFP from A100RA to A101; removed comment on the availability of BGA Pb-free package).
*C	351194	PCI	04/19/2005	Updated <a href="#">Ordering Information</a> (Updated part numbers).
*D	419264	RXU	01/10/2006	Changed status from Preliminary to Final. Changed address of Cypress Semiconductor Corporation from "3901 North First Street" to "198 Champion Court". Updated <a href="#">Electrical Characteristics</a> (Updated Note 15 (Changed test condition from $V_{DDQ} < V_{DD}$ to $V_{DDQ} \leq V_{DD}$ ), changed "Input Load Current except ZZ and MODE" to "Input Leakage Current except ZZ and MODE"). Updated <a href="#">Ordering Information</a> : Updated part numbers. Removed "Package Name" column. Added "Package Diagram" column. Updated <a href="#">Package Diagrams</a> : spec 51-85050 – Changed revision from *A to *B.
*E	419705	RXU	01/24/2006	Added 100 MHz Frequency Range related information in all instances across the document.
*F	480368	VKN	07/17/2006	Updated <a href="#">Maximum Ratings</a> : Added Maximum Rating for "Supply Voltage on $V_{DDQ}$ Relative to GND". Updated <a href="#">Ordering Information</a> : Updated part numbers.
*G	2896584	NJY	03/20/2010	Updated <a href="#">Ordering Information</a> : Updated part numbers. Updated <a href="#">Package Diagrams</a> : spec 51-85050 – Changed revision from *B to *C. spec 51-85115 – Changed revision from *B to *C.
*H	3053085	NJY	10/08/2010	Updated <a href="#">Ordering Information</a> : Updated part numbers. Added <a href="#">Ordering Code Definitions</a> . Added <a href="#">Acronyms</a> and <a href="#">Units of Measure</a> . Minor edits. Updated to new template. Completing Sunset Review.

**Document History Page** *(continued)*

Document Title: CY7C1350G, 4-Mbit (128K × 36) Pipelined SRAM with NoBL™ Architecture Document Number: 38-05524				
Rev.	ECN No.	Orig. of Change	Submission Date	Description of Change
*I	3211361	CS	03/31/2011	Updated <a href="#">Ordering Information</a> : Updated part numbers.
*J	3353361	PRIT	08/24/2011	Updated <a href="#">Functional Description</a> (Updated Note as “For best practices recommendations, refer to <a href="#">SRAM System Design Guidelines</a> .” and referred the note in same place in the section). Updated <a href="#">Package Diagrams</a> : spec 51-85050 – Changed revision from *C to *D. Completing Sunset Review.
*K	3590312	NJY / PRIT	05/10/2012	Removed 250 MHz, 166 MHz and 100 MHz Frequencies Range related information in all instances across the document. Updated <a href="#">Functional Description</a> : Updated description (Removed the Note “For best practices recommendations, refer to <a href="#">SRAM System Design Guidelines</a> .”).
*L	3753416	PRIT	09/24/2012	Updated <a href="#">Package Diagrams</a> : spec 51-85115 – Changed revision from *C to *D. Completing Sunset Review.
*M	3990978	PRIT	05/04/2013	Added <a href="#">Errata</a> .
*N	4039645	PRIT	06/25/2013	Added Errata Footnotes. Updated to new template.
*O	4150716	PRIT	12/13/2013	Updated <a href="#">Errata</a> .
*P	4574263	PRIT	11/19/2014	Updated <a href="#">Functional Description</a> : Added “For a complete list of related documentation, click <a href="#">here</a> .” at the end. Updated <a href="#">Ordering Information</a> : Updated part numbers. Updated <a href="#">Package Diagrams</a> : spec 51-85050 – Changed revision from *D to *E.
*Q	5512429	PRIT	11/07/2016	Updated <a href="#">Package Diagrams</a> : spec 51-85050 – Changed revision from *E to *F. Updated to new template. Completing Sunset Review.
*R	6021180	RMES	01/09/2018	Updated <a href="#">Package Diagrams</a> : spec 51-85050 – Changed revision from *F to *G. Updated to new template. Completing Sunset Review.
*S	6532203	RMES	04/03/2019	Updated <a href="#">Ordering Information</a> : Updated part numbers. Updated to new template.

## Sales, Solutions, and Legal Information

### Worldwide Sales and Design Support

Cypress maintains a worldwide network of offices, solution centers, manufacturer's representatives, and distributors. To find the office closest to you, visit us at [Cypress Locations](#).

#### Products

Arm <sup>®</sup> Cortex <sup>®</sup> Microcontrollers	<a href="http://cypress.com/arm">cypress.com/arm</a>
Automotive	<a href="http://cypress.com/automotive">cypress.com/automotive</a>
Clocks & Buffers	<a href="http://cypress.com/clocks">cypress.com/clocks</a>
Interface	<a href="http://cypress.com/interface">cypress.com/interface</a>
Internet of Things	<a href="http://cypress.com/iot">cypress.com/iot</a>
Memory	<a href="http://cypress.com/memory">cypress.com/memory</a>
Microcontrollers	<a href="http://cypress.com/mcu">cypress.com/mcu</a>
PSoC	<a href="http://cypress.com/psoc">cypress.com/psoc</a>
Power Management ICs	<a href="http://cypress.com/pmic">cypress.com/pmic</a>
Touch Sensing	<a href="http://cypress.com/touch">cypress.com/touch</a>
USB Controllers	<a href="http://cypress.com/usb">cypress.com/usb</a>
Wireless Connectivity	<a href="http://cypress.com/wireless">cypress.com/wireless</a>

#### PSoC<sup>®</sup> Solutions

[PSoC 1](#) | [PSoC 3](#) | [PSoC 4](#) | [PSoC 5LP](#) | [PSoC 6 MCU](#)

#### Cypress Developer Community

[Community](#) | [Projects](#) | [Video](#) | [Blogs](#) | [Training](#) | [Components](#)

#### Technical Support

[cypress.com/support](http://cypress.com/support)



© Cypress Semiconductor Corporation, 2004–2019. This document is the property of Cypress Semiconductor Corporation and its subsidiaries ("Cypress"). This document, including any software or firmware included or referenced in this document ("Software"), is owned by Cypress under the intellectual property laws and treaties of the United States and other countries worldwide. Cypress reserves all rights under such laws and treaties and does not, except as specifically stated in this paragraph, grant any license under its patents, copyrights, trademarks, or other intellectual property rights. If the Software is not accompanied by a license agreement and you do not otherwise have a written agreement with Cypress governing the use of the Software, then Cypress hereby grants you a personal, non-exclusive, nontransferable license (without the right to sublicense) (1) under its copyright rights in the Software (a) for Software provided in source code form, to modify and reproduce the Software solely for use with Cypress hardware products, only internally within your organization, and (b) to distribute the Software in binary code form externally to end users (either directly or indirectly through resellers and distributors), solely for use on Cypress hardware product units, and (2) under those claims of Cypress's patents that are infringed by the Software (as provided by Cypress, unmodified) to make, use, distribute, and import the Software solely for use with Cypress hardware products. Any other use, reproduction, modification, translation, or compilation of the Software is prohibited.

TO THE EXTENT PERMITTED BY APPLICABLE LAW, CYPRESS MAKES NO WARRANTY OF ANY KIND, EXPRESS OR IMPLIED, WITH REGARD TO THIS DOCUMENT OR ANY SOFTWARE OR ACCOMPANYING HARDWARE, INCLUDING, BUT NOT LIMITED TO, THE IMPLIED WARRANTIES OF MERCHANTABILITY AND FITNESS FOR A PARTICULAR PURPOSE. No computing device can be absolutely secure. Therefore, despite security measures implemented in Cypress hardware or software products, Cypress shall have no liability arising out of any security breach, such as unauthorized access to or use of a Cypress product. CYPRESS DOES NOT REPRESENT, WARRANT, OR GUARANTEE THAT CYPRESS PRODUCTS, OR SYSTEMS CREATED USING CYPRESS PRODUCTS, WILL BE FREE FROM CORRUPTION, ATTACK, VIRUSES, INTERFERENCE, HACKING, DATA LOSS OR THEFT, OR OTHER SECURITY INTRUSION (collectively, "Security Breach"). Cypress disclaims any liability relating to any Security Breach, and you shall and hereby do release Cypress from any claim, damage, or other liability arising from any Security Breach. In addition, the products described in these materials may contain design defects or errors known as errata which may cause the product to deviate from published specifications. To the extent permitted by applicable law, Cypress reserves the right to make changes to this document without further notice. Cypress does not assume any liability arising out of the application or use of any product or circuit described in this document. Any information provided in this document, including any sample design information or programming code, is provided only for reference purposes. It is the responsibility of the user of this document to properly design, program, and test the functionality and safety of any application made of this information and any resulting product. "High-Risk Device" means any device or system whose failure could cause personal injury, death, or property damage. Examples of High-Risk Devices are weapons, nuclear installations, surgical implants, and other medical devices. "Critical Component" means any component of a High-Risk Device whose failure to perform can be reasonably expected to cause, directly or indirectly, the failure of the High-Risk Device, or to affect its safety or effectiveness. Cypress is not liable, in whole or in part, and you shall and hereby do release Cypress from any claim, damage, or other liability arising from any use of a Cypress product as a Critical Component in a High-Risk Device. You shall indemnify and hold Cypress, its directors, officers, employees, agents, affiliates, distributors, and assigns harmless from and against all claims, costs, damages, and expenses, arising out of any claim, including claims for product liability, personal injury or death, or property damage arising from any use of a Cypress product as a Critical Component in a High-Risk Device. Cypress products are not intended or authorized for use as a Critical Component in any High-Risk Device except to the limited extent that (i) Cypress's published data sheet for the product explicitly states Cypress has qualified the product for use in a specific High-Risk Device, or (ii) Cypress has given you advance written authorization to use the product as a Critical Component in the specific High-Risk Device and you have signed a separate indemnification agreement.

Cypress, the Cypress logo, Spansion, the Spansion logo, and combinations thereof, WICED, PSoC, CapSense, EZ-USB, F-RAM, and Traveo are trademarks or registered trademarks of Cypress in the United States and other countries. For a more complete list of Cypress trademarks, visit [cypress.com](http://cypress.com). Other names and brands may be claimed as property of their respective owners.

## Looking for pricing, stock, or lifecycle information?

Click below to explore more details on WIN SOURCE:

-  [View CY7C1350G-200AXC on WIN SOURCE](#)
-  [Cypress Semiconductor Corp Information](#)

## Optimize Your Supply Chain with WIN SOURCE Solutions

-  Global Sourcing Solution
-  Obsolete Management
-  Cost Control Management
-  Shortage Management
-  Alternative Solution
-  Excess Inventory Management