



**THE DATASHEET OF
CY7C1347F-133AC**



4-Mb (128K x 36) Pipelined Sync SRAM

Features

- Fully registered inputs and outputs for pipelined operation
- 128K by 36 common I/O architecture
- 3.3V core power supply
- 2.5V/3.3V I/O operation
- Fast clock-to-output times
 - 2.6 ns (for 250-MHz device)
 - 2.6 ns (for 225-MHz device)
 - 2.8 ns (for 200-MHz device)
 - 3.5 ns (for 166-MHz device)
 - 4.0 ns (for 133-MHz device)
 - 4.5 ns (for 100-MHz device)
- User-selectable burst counter supporting Intel® Pentium® interleaved or linear burst sequences
- Separate processor and controller address strobes
- Synchronous self-timed writes
- Asynchronous output enable
- JEDEC-standard 100-pin TQFP, 119-pin BGA and 165-pin fBGA packages
- “ZZ” Sleep Mode option and Stop Clock option
- Available in Industrial and Commercial temperature ranges

Functional Description^[1]

The CY7C1347F is a 3.3V, 128K by 36 synchronous-pipelined SRAM designed to support zero-wait-state secondary cache with minimal glue logic.

CY7C1347F I/O pins can operate at either the 2.5V or the 3.3V level, the I/O pins are 3.3V tolerant when $V_{DDQ} = 2.5V$.

All synchronous inputs pass through input registers controlled by the rising edge of the clock. All data outputs pass through output registers controlled by the rising edge of the clock. Maximum access delay from the clock rise is 2.6 ns (250-MHz device)

CY7C1347F supports either the interleaved burst sequence used by the Intel Pentium processor or a linear burst sequence used by processors such as the PowerPC®. The burst sequence is selected through the MODE pin. Accesses can be initiated by asserting either the Address Strobe from Processor (ADSP) or the Address Strobe from Controller (ADSC) at clock rise. Address advancement through the burst sequence is controlled by the ADV input. A 2-bit on-chip wraparound burst counter captures the first address in a burst sequence and automatically increments the address for the rest of the burst access.

Byte write operations are qualified with the four Byte Write Select ($BW_{[A:D]}$) inputs. A Global Write Enable (GW) overrides all byte write inputs and writes data to all four bytes. All writes are conducted with on-chip synchronous self-timed write circuitry.

Three synchronous Chip Selects ($\overline{CE}_1, CE_2, \overline{CE}_3$) and an asynchronous Output Enable (OE) provide for easy bank selection and output three-state control. In order to provide proper data during depth expansion, OE is masked during the first clock of a read cycle when emerging from a deselected state.

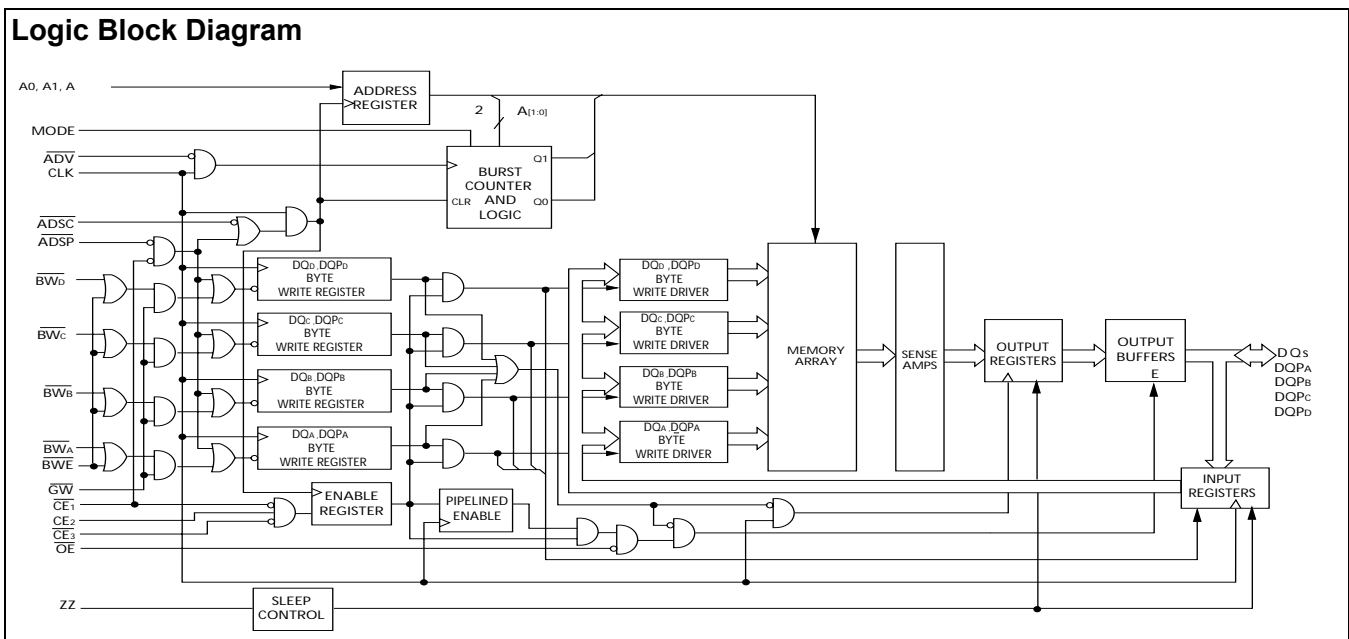

Note:

1. For best-practices recommendations, please refer to the Cypress application note *System Design Guidelines* on www.cypress.com.

Selection Guide

	-250	-225	-200	-166	-133	-100	Unit
Maximum Access Time	2.6	2.6	2.8	3.5	4.0	4.5	ns
Maximum Operating Current	325	290	265	240	225	205	mA
Maximum CMOS Standby Current	40	40	40	40	40	40	mA

Shaded areas contain advance information. Please contact your local Cypress Sales representative for availability of these parts.

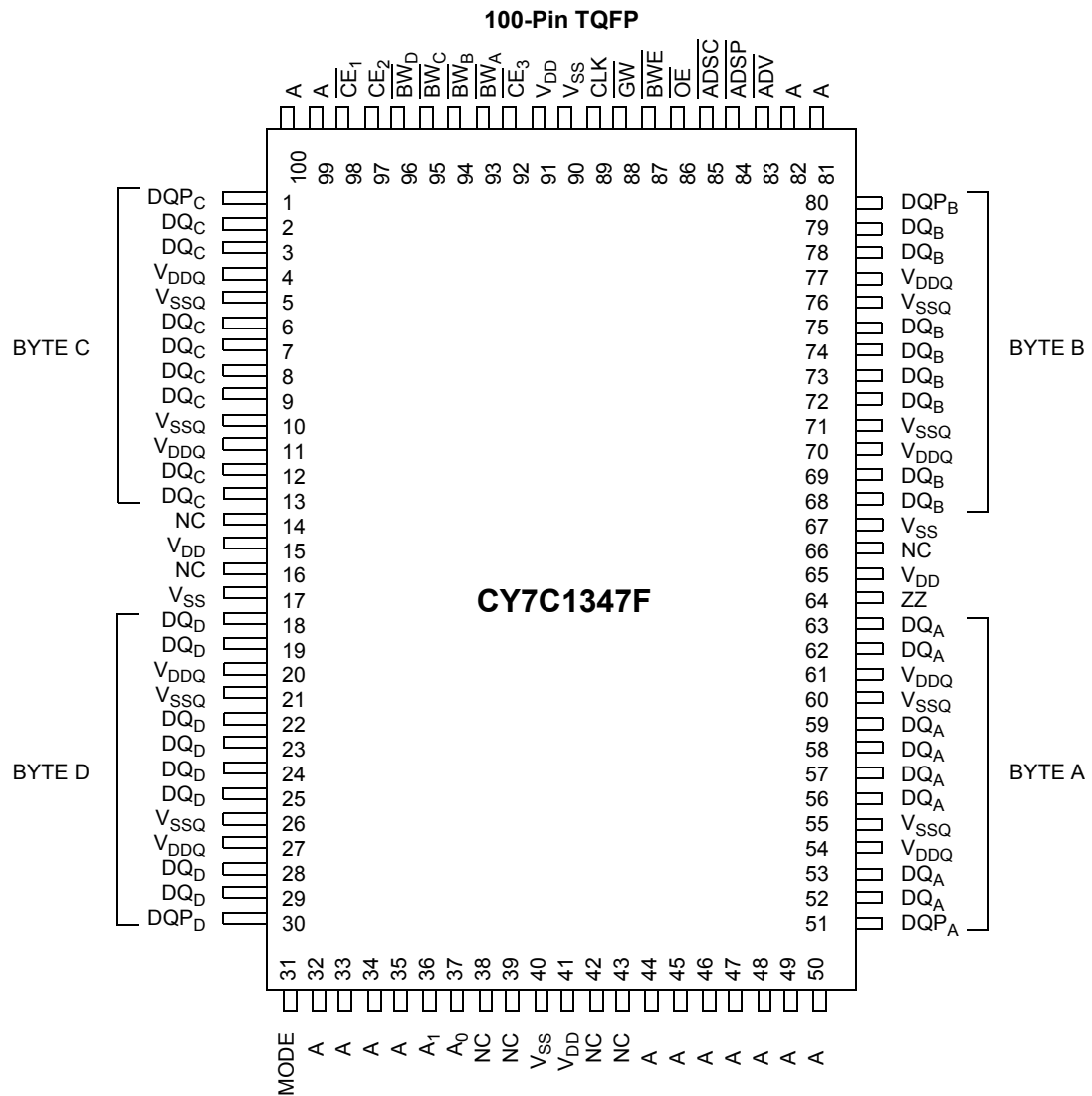
Pin Configurations

Pin Configurations (continued)

119-Ball BGA

	1	2	3	4	5	6	7
A	V _{DDQ}	A	A	$\overline{\text{ADSP}}$	A	A	V _{DDQ}
B	NC	CE ₂	A	$\overline{\text{ADSC}}$	A	$\overline{\text{CE}}_3$	NC
C	NC	A	A	V _{DD}	A	A	NC
D	DQ _C	DQP _C	V _{SS}	NC	V _{SS}	DQP _B	DQ _B
E	DQ _C	DQ _C	V _{SS}	$\overline{\text{CE}}_1$	V _{SS}	DQ _B	DQ _B
F	V _{DDQ}	DQ _C	V _{SS}	$\overline{\text{OE}}$	V _{SS}	DQ _B	V _{DDQ}
G	DQ _C	DQ _C	$\overline{\text{BW}}_C$	$\overline{\text{ADV}}$	$\overline{\text{BW}}_B$	DQ _B	DQ _B
H	DQ _C	DQ _C	V _{SS}	$\overline{\text{GW}}$	V _{SS}	DQ _B	DQ _B
J	V _{DDQ}	V _{DD}	NC	V _{DD}	NC	V _{DD}	V _{DDQ}
K	DQ _D	DQ _D	V _{SS}	CLK	V _{SS}	DQ _A	DQ _A
L	DQ _D	DQ _D	$\overline{\text{BW}}_D$	NC	$\overline{\text{BW}}_A$	DQ _A	DQ _A
M	V _{DDQ}	DQ _D	V _{SS}	$\overline{\text{BWE}}$	V _{SS}	DQ _A	V _{DDQ}
N	DQ _D	DQ _D	V _{SS}	A1	V _{SS}	DQ _A	DQ _A
P	DQ _D	DQP _D	V _{SS}	A0	V _{SS}	DQP _A	DQ _A
R	NC	A	MODE	V _{DD}	NC	A	NC
T	NC	NC	A	A	A	NC	ZZ
U	V _{DDQ}	NC	NC	NC	NC	NC	V _{DDQ}

165-Ball fBGA

	1	2	3	4	5	6	7	8	9	10	11
A	NC	A	$\overline{\text{CE}}_1$	$\overline{\text{BW}}_C$	$\overline{\text{BW}}_B$	$\overline{\text{CE}}_1$	$\overline{\text{BWE}}$	$\overline{\text{ADSC}}$	$\overline{\text{ADV}}$	A	NC
B	NC	A	CE ₂	$\overline{\text{BW}}_D$	$\overline{\text{BW}}_A$	CLK	$\overline{\text{GW}}$	$\overline{\text{OE}}$	$\overline{\text{ADSP}}$	A	NC
C	DQP _C	NC	V _{DDQ}	V _{SS}	V _{SS}	V _{SS}	V _{SS}	V _{SS}	V _{DDQ}	NC	DQP _B
D	DQ _C	DQ _C	V _{DDQ}	V _{DD}	V _{SS}	V _{SS}	V _{SS}	V _{DD}	V _{DDQ}	DQ _B	DQ _B
E	DQ _C	DQ _C	V _{DDQ}	V _{DD}	V _{SS}	V _{SS}	V _{SS}	V _{DD}	V _{DDQ}	DQ _B	DQ _B
F	DQ _C	DQ _C	V _{DDQ}	V _{DD}	V _{SS}	V _{SS}	V _{SS}	V _{DD}	V _{DDQ}	DQ _B	DQ _B
G	DQ _C	DQ _C	V _{DDQ}	V _{DD}	V _{SS}	V _{SS}	V _{SS}	V _{DD}	V _{DDQ}	DQ _B	DQ _B
H	NC	V _{SS}	NC	V _{DD}	V _{SS}	V _{SS}	V _{SS}	V _{DD}	NC	NC	ZZ
J	DQ _D	DQ _D	V _{DDQ}	V _{DD}	V _{SS}	V _{SS}	V _{SS}	V _{DD}	V _{DDQ}	DQ _A	DQ _A
K	DQ _D	DQ _D	V _{DDQ}	V _{DD}	V _{SS}	V _{SS}	V _{SS}	V _{DD}	V _{DDQ}	DQ _A	DQ _A
L	DQ _D	DQ _D	V _{DDQ}	V _{DD}	V _{SS}	V _{SS}	V _{SS}	V _{DD}	V _{DDQ}	DQ _A	DQ _A
M	DQ _D	DQ _D	V _{DDQ}	V _{DD}	V _{SS}	V _{SS}	V _{SS}	V _{DD}	V _{DDQ}	DQ _A	DQ _A
N	DQP _D	NC	V _{DDQ}	V _{SS}	NC	NC	V _{SS}	V _{SS}	V _{DDQ}	NC	DQP _A
P	NC	NC	A	A	NC	A1	NC	A	A	A	NC
R	MODE	NC	A	A	NC	A0	NC	A	A	A	A

Pin Definitions

Name (BGA,FBGA)	Name (100TQFP)	I/O	Description
A ₀ ,A ₁ ,A	A _[16:0]	Input-Synchronous	Address Inputs used to select one of the 128K address locations. Sampled at the rising edge of the CLK if ADSP or ADSC is active LOW, and \overline{CE}_1 , CE ₂ , and CE ₃ are sampled active. A _[1:0] feeds the 2-bit counter.
\overline{BW}_A , \overline{BW}_B , \overline{BW}_C , \overline{BW}_D	$\overline{BW}_{[A:D]}$	Input-Synchronous	Byte Write Select Inputs, active LOW. Qualified with \overline{BWE} to conduct byte writes to the SRAM. Sampled on the rising edge of CLK.
\overline{GW}	\overline{GW}	Input-Synchronous	Global Write Enable Input, active LOW. When asserted LOW on the rising edge of CLK, a global write is conducted (ALL bytes are written, regardless of the values on $\overline{BW}_{[A:D]}$ and BWE).
\overline{BWE}	\overline{BWE}	Input-Synchronous	Byte Write Enable Input, active LOW. Sampled on the rising edge of CLK. This signal must be asserted LOW to conduct a byte write.
CLK	CLK	Input-Clock	Clock Input. Used to capture all synchronous inputs to the device. Also used to increment the burst counter when ADV is asserted LOW, during a burst operation.
\overline{CE}_1	\overline{CE}_1	Input-Synchronous	Chip Enable 1 Input, active LOW. Sampled on the rising edge of CLK. Used in conjunction with CE ₂ and CE ₃ to select/deselect the device. ADSP is ignored if \overline{CE}_1 is HIGH.
CE ₂	CE ₂	Input-Synchronous	Chip Enable 2 Input, active HIGH. Sampled on the rising edge of CLK. Used in conjunction with \overline{CE}_1 and CE ₃ to select/deselect the device.
\overline{CE}_3	\overline{CE}_3	Input-Synchronous	Chip Enable 3 Input, active LOW. Sampled on the rising edge of CLK. Used in conjunction with \overline{CE}_1 and CE ₂ to select/deselect the device.
\overline{OE}	\overline{OE}	Input-Asynchronous	Output Enable, asynchronous input, active LOW. Controls the direction of the I/O pins. When LOW, the I/O pins behave as outputs. When deasserted HIGH, I/O pins are three-stated, and act as input data pins. OE is masked during the first clock of a read cycle when emerging from a deselected state.
\overline{ADV}	\overline{ADV}	Input-Synchronous	Advance Input signal, sampled on the rising edge of CLK. When asserted, it automatically increments the address in a burst cycle.
\overline{ADSP}	\overline{ADSP}	Input-Synchronous	Address Strobe from Processor, sampled on the rising edge of CLK. When asserted LOW, addresses presented to the device are captured in the address registers. A _[1:0] are also loaded into the burst counter. When \overline{ADSP} and ADSC are both asserted, only ADSP is recognized. ADSP is ignored when \overline{CE}_1 is deasserted HIGH.
\overline{ADSC}	\overline{ADSC}	Input-Synchronous	Address Strobe from Controller, sampled on the rising edge of CLK. When asserted LOW, addresses presented to the device are captured in the address registers. A _[1:0] are also loaded into the burst counter. When \overline{ADSP} and ADSC are both asserted, only ADSP is recognized.
ZZ	ZZ	Input-Asynchronous	ZZ “sleep” Input. This active HIGH input places the device in a non-time-critical “sleep” condition with data integrity preserved. For normal operation, this pin has to be LOW or left floating. ZZ pin has an internal pull-down.
DQ _A , DQ _B , DQ _C , DQ _D , DQP _A , DQP _B , DQP _C , DQP _D	DQs DQPs	I/O-Synchronous	Bidirectional Data I/O lines. As inputs, they feed into an on-chip data register that is triggered by the rising edge of CLK. As outputs, they deliver the data contained in the memory location specified by the addresses presented during the previous clock rise of the read cycle. The direction of the pins is controlled by OE. When OE is asserted LOW, the pins behave as outputs. When HIGH, DQs and DQPs are placed in a three-state condition.
V _{DD}	V _{DD}	Power Supply	Power supply inputs to the core of the device.
V _{SS}	V _{SS}	Ground	Ground for the core of the device.
V _{DDQ}	V _{DDQ}	I/O Power Supply	Power supply for the I/O circuitry.
V _{SSQ}	V _{SSQ}	I/O Ground	Ground for the I/O circuitry.
MODE	MODE	Input-Static	Selects Burst Order. When tied to GND selects linear burst sequence. When tied to V _{DDQ} or left floating selects interleaved burst sequence. This is a strap pin and should remain static during device operation. Mode Pin has an internal pull-up.
NC	NC		No Connects.

Introduction

Functional Overview

All synchronous inputs pass through input registers controlled by the rising edge of the clock. All data outputs pass through output registers controlled by the rising edge of the clock. Maximum access delay from the clock rise (T_{CO}) is 2.6 ns (250-MHz device).

The CY7C1347F supports secondary cache in systems utilizing either a linear or interleaved burst sequence. The linear burst sequence is suited for processors that utilize a linear burst sequence. The burst order is user selectable, and is determined by sampling the MODE input. Accesses can be initiated with either the Address Strobe from Processor (ADSP) or the Address Strobe from Controller (ADSC). Address advancement through the burst sequence is controlled by the ADV input. A two-bit on-chip wraparound burst counter captures the first address in a burst sequence and automatically increments the address for the rest of the burst access.

Byte write operations are qualified with the Byte Write Enable (BWE) and Byte Write Select ($BW_{[A:D]}$) inputs. A Global Write Enable (GW) overrides all byte write inputs and writes data to all four bytes. All writes are simplified with on-chip synchronous self-timed write circuitry.

Three synchronous Chip Selects (\overline{CE}_1 , CE_2 , \overline{CE}_3) and an asynchronous Output Enable (\overline{OE}) provide for easy bank selection and output three-state control. ADSP is ignored if CE_1 is HIGH.

Single Read Accesses

This access is initiated when the following conditions are satisfied at clock rise: (1) ADSP or ADSC is asserted LOW, (2) \overline{CE}_1 , CE_2 , \overline{CE}_3 are all asserted active, and (3) the write signals (GW, BWE) are all deasserted HIGH. ADSP is ignored if CE_1 is HIGH. The address presented to the address inputs ($A_{[16:0]}$) is stored into the address advancement logic and the Address Register while being presented to the memory core. The corresponding data is allowed to propagate to the input of the Output Registers. At the rising edge of the next clock the data is allowed to propagate through the Output Register and onto the data bus within 2.6 ns (250-MHz device) if OE is active LOW. The only exception occurs when the SRAM is emerging from a deselected state to a selected state, its outputs are always three-stated during the first cycle of the access. After the first cycle of the access, the outputs are controlled by the OE signal. Consecutive single read cycles are supported. Once the SRAM is deselected at clock rise by the chip select and either ADSP or ADSC signals, its output will three-state immediately.

Single Write Accesses Initiated by \overline{ADSP}

This access is initiated when both of the following conditions are satisfied at clock rise: (1) ADSP is asserted LOW, and (2) CE_1 , CE_2 , CE_3 are all asserted active. The address presented to $A_{[16:0]}$ is loaded into the Address Register and the address advancement logic while being delivered to the RAM core. The write signals (GW, BWE, and $BW_{[A:D]}$) and ADV inputs are ignored during this first cycle.

ADSP-triggered write accesses require two clock cycles to complete. If GW is asserted LOW on the second clock rise, the data presented to the DQs and DQPs inputs is written into the

corresponding address location in the RAM core. If \overline{GW} is HIGH, then the write operation is controlled by BWE and $BW_{[A:D]}$ signals. The CY7C1347F provides byte write capability that is described in the Write Cycle Description table. Asserting the Byte Write Enable input (BWE) with the selected Byte Write ($BW_{[A:D]}$) input will selectively write to only the desired bytes.

Bytes not selected during a byte write operation will remain unaltered. A synchronous self-timed write mechanism has been provided to simplify the write operations.

Because the CY7C1347F is a common I/O device, the Output Enable (OE) must be deasserted HIGH before presenting data to the DQs and DQPs inputs. Doing so will three-state the output drivers. As a safety precaution, DQs and DQPs are automatically three-stated whenever a write cycle is detected, regardless of the state of \overline{OE} .

Single Write Accesses Initiated by \overline{ADSC}

ADSC write accesses are initiated when the following conditions are satisfied: (1) ADSC is asserted LOW, (2) ADSP is deasserted HIGH, (3) \overline{CE}_1 , CE_2 , \overline{CE}_3 are all asserted active, and (4) the appropriate combination of the write inputs (GW, BWE, and $BW_{[A:D]}$) are asserted active to conduct a write to the desired byte(s). ADSC-triggered write accesses require a single clock cycle to complete. The address presented to $A_{[16:0]}$ is loaded into the address register and the address advancement logic while being delivered to the RAM core. The ADV input is ignored during this cycle. If a global write is conducted, the data presented to the DQs and DQPs is written into the corresponding address location in the RAM core. If a byte write is conducted, only the selected bytes are written. Bytes not selected during a byte write operation will remain unaltered. A synchronous self-timed write mechanism has been provided to simplify the write operations.

Because the CY7C1347F is a common I/O device, the Output Enable (OE) must be deasserted HIGH before presenting data to the DQs and DQPs inputs. Doing so will three-state the output drivers. As a safety precaution, DQs and DQPs are automatically three-stated whenever a write cycle is detected, regardless of the state of OE.

Burst Sequences

The CY7C1347F provides a two-bit wraparound counter, fed by $A_{[1:0]}$, that implements either an interleaved or linear burst sequence. The interleaved burst sequence is designed specifically to support Intel Pentium applications. The linear burst sequence is designed to support processors that follow a linear burst sequence. The burst sequence is user-selectable through the MODE input.

Asserting \overline{ADV} LOW at clock rise will automatically increment the burst counter to the next address in the burst sequence. Both read and write burst operations are supported.

Sleep Mode

The ZZ input pin is an asynchronous input. Asserting ZZ places the SRAM in a power conservation "sleep" mode. Two clock cycles are required to enter into or exit from this "sleep" mode. While in this mode, data integrity is guaranteed. Accesses pending when entering the "sleep" mode are not considered valid nor is the completion of the operation guaranteed. The device must be deselected prior to entering the "sleep" mode. CE_1 , CE_2 , CE_3 , ADSP, and ADSC must remain inactive for the duration of t_{ZZREC} after the ZZ input returns LOW.

Interleaved Burst Sequence

First Address	Second Address	Third Address	Fourth Address
A _[1:0]	A _[1:0]	A _[1:0]	A _[1:0]
00	01	10	11
01	00	11	10
10	11	00	01
11	10	01	00

Linear Burst Sequence

First Address	Second Address	Third Address	Fourth Address
A _[1:0]	A _[1:0]	A _[1:0]	A _[1:0]
00	01	10	11
01	10	11	00
10	11	00	01
11	00	01	10

ZZ Mode Electrical Characteristics

Parameter	Description	Test Conditions	Min.	Max.	Unit
I _{DDZZ}	Snooze mode standby current	ZZ ≥ V _{DD} - 0.2V		40	mA
t _{ZZS}	Device operation to ZZ	ZZ ≥ V _{DD} - 0.2V		2t _{CYC}	ns
t _{ZZREC}	ZZ recovery time	ZZ ≤ 0.2V	2t _{CYC}		ns
t _{ZZI}	ZZ Active to snooze current	This parameter is sampled		2t _{CYC}	ns
t _{RZZI}	ZZ Inactive to exit snooze current	This parameter is sampled	0		ns

Truth Table^[2, 3, 4, 5, 6]

Next Cycle	Add. Used	ZZ	\overline{CE}_3	CE ₂	\overline{CE}_1	\overline{ADSP}	\overline{ADSC}	\overline{ADV}	\overline{WRITE}	\overline{OE}	CLK	DQ
Deselect Cycle, Power-down	None	H	X	X	L	X	L	X	X	X	L-H	three-state
Deselect Cycle, Power-down	None	L	L	X	L	L	X	X	X	X	L-H	three-state
Deselect Cycle, Power-down	None	L	X	H	L	L	X	X	X	X	L-H	three-state
Deselect Cycle, Power-down	None	L	L	X	L	H	L	X	X	X	L-H	three-state
Deselect Cycle, Power-down	None	L	X	H	L	H	L	X	X	X	L-H	three-state
Snooze Mode, Power-down	None	X	X	X	H	X	X	X	X	X	X	three-state
READ Cycle, Begin Burst	External	L	H	L	L	L	X	X	X	L	L-H	Q
READ Cycle, Begin Burst	External	L	H	L	L	L	X	X	X	H	L-H	three-state
WRITE Cycle, Begin Burst	External	L	H	L	L	H	L	X	L	X	L-H	D
READ Cycle, Begin Burst	External	L	H	L	L	H	L	X	H	L	L-H	Q
READ Cycle, Begin Burst	External	L	H	L	L	H	L	X	H	H	L-H	three-state
READ Cycle, Continue Burst	Next	X	X	X	L	H	H	L	H	L	L-H	Q
READ Cycle, Continue Burst	Next	X	X	X	L	H	H	L	H	H	L-H	three-state
READ Cycle, Continue Burst	Next	H	X	X	L	X	H	L	H	L	L-H	Q
READ Cycle, Continue Burst	Next	H	X	X	L	X	H	L	H	H	L-H	three-state
WRITE Cycle, Continue Burst	Next	X	X	X	L	H	H	L	L	X	L-H	D
WRITE Cycle, Continue Burst	Next	H	X	X	L	X	H	L	L	X	L-H	D
READ Cycle, Suspend Burst	Current	X	X	X	L	H	H	H	H	L	L-H	Q
READ Cycle, Suspend Burst	Current	X	X	X	L	H	H	H	H	H	L-H	three-state
READ Cycle, Suspend Burst	Current	H	X	X	L	X	H	H	H	L	L-H	Q
READ Cycle, Suspend Burst	Current	H	X	X	L	X	H	H	H	H	L-H	three-state

Notes:

- X = "Don't Care." H = Logic HIGH, L = Logic LOW.
- $\overline{WRITE} = L$ when any one or more Byte Write enable signals (\overline{BW}_A , \overline{BW}_B , \overline{BW}_C , \overline{BW}_D) and $\overline{BWE} = L$ or $\overline{GW} = L$. $\overline{WRITE} = H$ when all Byte write enable signals (\overline{BW}_A , \overline{BW}_B , \overline{BW}_C , \overline{BW}_D), \overline{BWE} , $\overline{GW} = H$.
- The DQ pins are controlled by the current cycle and the \overline{OE} signal. \overline{OE} is asynchronous and is not sampled with the clock.
- The SRAM always initiates a read cycle when \overline{ADSP} asserted, regardless of the state of \overline{GW} , \overline{BWE} , or $\overline{BW}_{[A,D]}$. Writes may occur only on subsequent clocks after the \overline{ADSP} or with the assertion of \overline{ADSC} . As a result, \overline{OE} must be driven HIGH prior to the start of the write cycle to allow the outputs to three-state. \overline{OE} is a don't care for the remainder of the write cycle.
- \overline{OE} is asynchronous and is not sampled with the clock rise. It is masked internally during write cycles. During a read cycle all data bits are three-state when \overline{OE} is inactive or when the device is deselected, and all data bits behave as output when \overline{OE} is active (LOW).

Truth Table^[2, 3, 4, 5, 6]

Next Cycle	Add. Used	ZZ	\overline{CE}_3	CE_2	\overline{CE}_1	\overline{ADSP}	\overline{ADSC}	\overline{ADV}	\overline{WRITE}	\overline{OE}	CLK	DQ
WRITE Cycle, Suspend Burst	Current	X	X	X	L	H	H	H	L	X	L-H	D
WRITE Cycle, Suspend Burst	Current	H	X	X	L	X	H	H	L	X	L-H	D

Partial Truth Table for Read/write^[2, 7]

Function	\overline{GW}	\overline{BWE}	\overline{BW}_D	\overline{BW}_C	\overline{BW}_B	\overline{BW}_A
Read	H	H	X	X	X	X
Read	H	L	H	H	H	H
Write Byte A – DQ _A	H	L	H	H	H	L
Write Byte B – DQ _B	H	L	H	H	L	H
Write Bytes B, A	H	L	H	H	L	L
Write Byte C– DQ _C	H	L	H	L	H	H
Write Bytes C, A	H	L	H	L	H	L
Write Bytes C, B	H	L	H	L	L	H
Write Bytes C, B, A	H	L	H	L	L	L
Write Byte D– DQ _D	H	L	L	H	H	H
Write Bytes D, A	H	L	L	H	H	L
Write Bytes D, B	H	L	L	H	L	H
Write Bytes D, B, A	H	L	L	H	L	L
Write Bytes D, C	H	L	L	L	H	H
Write Bytes D, C, A	H	L	L	L	H	L
Write Bytes D, C, B	H	L	L	L	L	H
Write All Bytes	H	L	L	L	L	L
Write All Bytes	L	X	X	X	X	X

Notes:

7. Table only lists a partial listing of the byte write combinations. Any combination of $BW_{[A,D]}$ is valid. Appropriate write will be done based on which byte write is active.

Maximum Ratings

(Above which the useful life may be impaired. For user guidelines, not tested.)

Storage Temperature -65°C to +150°C
 Ambient Temperature with Power Applied..... -55°C to +125°C
 Supply Voltage on V_{DD} Relative to GND..... -0.5V to +4.6V
 DC Voltage Applied to Outputs in High-Z State -0.5V to V_{DD} + 0.5V
 DC Input Voltage -0.5V to V_{DD} + 0.5V

Current into Outputs (LOW)..... 20 mA
 Static Discharge Voltage..... > 2001V (per MIL-STD-883, Method 3015)
 Latch-up Current..... > 200 mA

Operating Range

Range	Ambient Temperature	V _{DD}	V _{DDQ}
Com'l	0°C to +70°C	3.3V -5%/+10%	2.5V -5% to V _{DD}
Ind'l	-40°C to +85°C		

Electrical Characteristics Over the Operating Range [8, 9]

Parameter	Description	Test Conditions	Min.	Max.	Unit	
V _{DD}	Power Supply Voltage		3.135	3.6	V	
V _{DDQ}	I/O Supply Voltage		2.375	V _{DD}	V	
V _{OH}	Output HIGH Voltage	V _{DDQ} = 3.3V, V _{DD} = Min., I _{OH} = -4.0 mA	2.4		V	
		V _{DDQ} = 2.5V, V _{DD} = Min., I _{OH} = -2.0 mA	2.0		V	
V _{OL}	Output LOW Voltage	V _{DDQ} = 3.3V, V _{DD} = Min., I _{OL} = 8.0 mA		0.4	V	
		V _{DDQ} = 2.5V, V _{DD} = Min., I _{OL} = 2.0 mA		0.7	V	
V _{IH}	Input HIGH Voltage ^[8]	V _{DDQ} = 3.3V	2.0	V _{DD} + 0.3V	V	
		V _{DDQ} = 2.5V	1.7	V _{DD} + 0.3V	V	
V _{IL}	Input LOW Voltage ^[8]	V _{DDQ} = 3.3V	-0.3	0.8	V	
		V _{DDQ} = 2.5V	-0.3	0.7	V	
I _X	Input Load Current except ZZ and MODE	GND ≤ V _I ≤ V _{DDQ}	-5	5	μA	
		Input Current of MODE	Input = V _{SS}	-30		μA
	Input Current of ZZ	Input = V _{SS}	-5		μA	
		Input = V _{DDQ}		30	μA	
I _{OZ}	Output Leakage Current	GND ≤ V _I ≤ V _{DDQ} , Output Disabled	-5	5	μA	
I _{DD}	V _{DD} Operating Supply Current	V _{DD} = Max., I _{OUT} = 0 mA, f = f _{MAX} = 1/t _{CYC}	4-ns cycle, 250 MHz		325	mA
			4.4-ns cycle, 225 MHz		290	mA
			5-ns cycle, 200 MHz		265	mA
			6-ns cycle, 166 MHz		240	mA
			7.5-ns cycle, 133 MHz		225	mA
			10-ns cycle, 100 MHz		205	mA
I _{SB1}	Automatic CE Power-down Current—TTL Inputs	Max. V _{DD} , Device Deselected, V _{IN} ≥ V _{IH} or V _{IN} ≤ V _{IL} , f = f _{MAX} = 1/t _{CYC}	4-ns cycle, 250 MHz		120	mA
			4.4-ns cycle, 225 MHz		115	mA
			5-ns cycle, 200 MHz		110	mA
			6-ns cycle, 166 MHz		100	mA
			7.5-ns cycle, 133 MHz		90	mA
			10-ns cycle, 100 MHz		80	mA
I _{SB2}	Automatic CE Power-down Current—CMOS Inputs	Max. V _{DD} , Device Deselected, V _{IN} ≤ 0.3V or V _{IN} ≥ V _{DDQ} - 0.3V, f = 0	All speeds		40	mA

Notes:

- Overshoot: V_{IH}(AC) < V_{DD} + 1.5V (Pulse width less than t_{CYC}/2), undershoot: V_{IL}(AC) > -2V (Pulse width less than t_{CYC}/2).
- T_{Power-up}: Assumes a linear ramp from 0v to V_{DD}(min.) within 200ms. During this time V_{IH} ≤ V_{DD} and V_{DDQ} ≤ V_{DD}

Electrical Characteristics Over the Operating Range (continued)^[8, 9]

Parameter	Description	Test Conditions	Min.	Max.	Unit	
I _{SB3}	Automatic CE Power-down Current—CMOS Inputs	Max. V _{DD} , Device Deselected, or V _{IN} ≤ 0.3V or V _{IN} ≥ V _{DDQ} - 0.3V f = f _{MAX} = 1/t _{CYC}	4-ns cycle, 250 MHz		105	mA
			4.4-ns cycle, 225 MHz		100	mA
			5-ns cycle, 200 MHz		95	mA
			6-ns cycle, 166 MHz		85	mA
			7.5-ns cycle, 133 MHz		75	mA
			10-ns cycle, 100 MHz		65	mA
I _{SB4}	Automatic CE Power-down Current—TTL Inputs	Max. V _{DD} , Device Deselected, V _{IN} ≥ V _{IH} or V _{IN} ≤ V _{IL} , f = 0		45	mA	

Shaded areas contain advance information.

Capacitance^[10]

Parameter	Description	Test Conditions	TQFP Package	BGA Package	fBGA Package	Unit
C _{IN}	Input Capacitance	T _A = 25°C, f = 1 MHz, V _{DD} = 3.3V, V _{DDQ} = 3.3V	5	5	5	pF
C _{CLK}	Clock Input Capacitance		5	5	5	pF
C _{I/O}	Input/Output Capacitance		5	7	7	pF

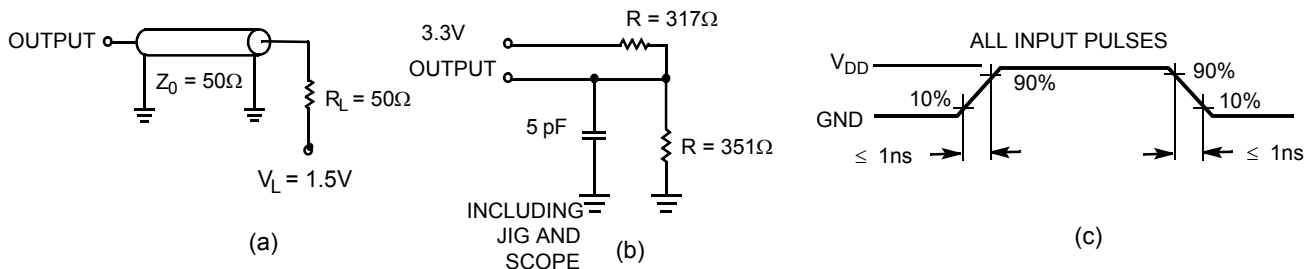
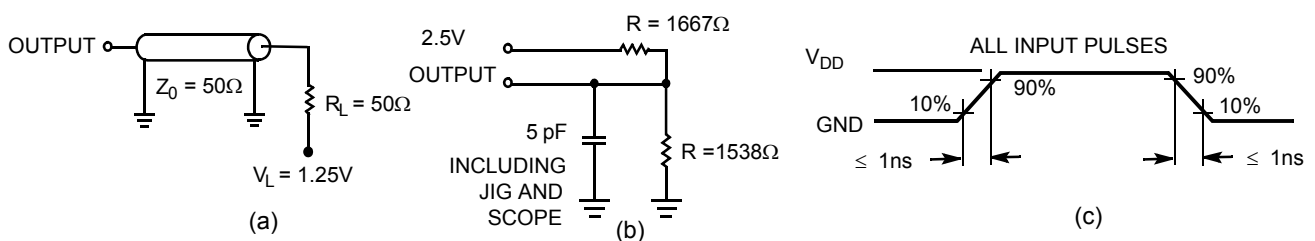
AC Test Loads and Waveforms
3.3V I/O Test Load

2.5V I/O Test Load

Thermal Resistance^[10]

Parameter	Description	Test Conditions	TQFP Package	BGA Package	fBGA Package	Unit
Q _{JA}	Thermal Resistance (Junction to Ambient)	Test conditions follow standard test methods and procedures for measuring thermal impedance, per EIA / JESD51.	41.83	47.63	20.3	°C/W
Q _{JC}	Thermal Resistance (Junction to Case)		9.99	11.71	4.6	°C/W

Note:

10. Tested initially and after any design or process changes that may affect these parameters.

Switching Characteristics Over the Operating Range^[15, 16]

Parameter	Description	-250		-225		-200		-166		-133		-100		Unit
		Min.	Max.	Min.	Max.	Min.	Max.	Min.	Max.	Min.	Max.	Min.	Max.	
t _{POWER}	V _{DD} (min.) to the first access read or write ^[11]	1		1		1		1		1		1		ms
t _{CYC}	Clock Cycle Time	4.0		4.4		5.0		6.0		7.5		10		ns
t _{CH}	Clock HIGH	1.7		2.0		2.0		2.5		3.0		3.5		ns
t _{CL}	Clock LOW	1.7		2.0		2.0		2.5		3.0		3.5		ns
t _{AS}	Address Set-up Before CLK Rise	0.8		1.2		1.2		1.5		1.5		1.5		ns
t _{AH}	Address Hold After CLK Rise	0.4		0.5		0.5		0.5		0.5		0.5		ns
t _{CO}	Data Output Valid After CLK Rise		2.6		2.6		2.8		3.5		4.0		4.5	ns
t _{DOH}	Data Output Hold After CLK Rise	1.0		1.0		1.0		2.0		2.0		2.0		ns
t _{WES}	GW, BWS _[3:0] Set-up Before CLK Rise	0.8		1.2		1.2		1.5		1.5		1.5		ns
t _{WEH}	GW, BWS _[3:0] Hold After CLK Rise	0.4		0.5		0.5		0.5		0.5		0.5		ns
t _{ALS}	ADV/LD Set-up Before CLK Rise	0.8		1.2		1.2		1.5		1.5		1.5		ns
t _{ALH}	ADV/LD Hold after CLK Rise	0.4		0.5		0.5		0.5		0.5		0.5		ns
t _{DS}	Data Input Set-up Before CLK Rise	0.8		1.2		1.2		1.5		1.5		1.5		ns
t _{DH}	Data Input Hold After CLK Rise	0.4		0.5		0.5		0.5		0.5		0.5		ns
t _{CES}	Chip Enable Set-up Before CLK Rise	0.8		1.2		1.2		1.5		1.5		1.5		ns
t _{CEH}	Chip Enable Hold After CLK Rise	0.4		0.5		0.5		0.5		0.5		0.5		ns
t _{CHZ}	Clock to High-Z ^[12, 13, 14]		2.6		2.6		2.8		3.5		4.0		4.5	ns
t _{CLZ}	Clock to Low-Z ^[12, 13, 14]	0		0		0		0		0		0		ns
t _{EOHZ}	OE HIGH to Output High-Z ^[12, 13, 14]		2.6		2.6		2.8		3.5		4.0		4.5	ns
t _{EOLZ}	OE LOW to Output Low-Z ^[12, 13, 14]	0		0		0		0		0		0		ns
t _{EOV}	OE LOW to Output Valid		2.6		2.6		2.8		3.5		4.5		4.5	ns

Notes:

11. This part has a voltage regulator internally; t_{POWER} is the time that the power needs to be supplied above V_{DD}(minimum) initially before a read or write operation can be initiated.
12. t_{CHZ}, t_{CLZ}, t_{EOHZ}, and t_{EOLZ} are specified with AC test conditions shown in part (b) of AC Test Loads. Transition is measured ± 200 mV from steady-state voltage.
13. At any given voltage and temperature, t_{EOHZ} is less than t_{EOLZ} and t_{CHZ} is less than t_{CLZ} to eliminate bus contention between SRAMs when sharing the same data bus. These specifications do not imply a bus contention condition, but reflect parameters guaranteed over worst case user conditions. Device is designed to achieve High-Z prior to Low-Z under the same system conditions.
14. This parameter is sampled and not 100% tested.
15. Timing references level is 1.5V when V_{DDQ} = 3.3V and is 1.25V when V_{DDQ} = 2.5V on all data sheets.
16. Test conditions shown in (a) of AC Test Loads unless otherwise noted.

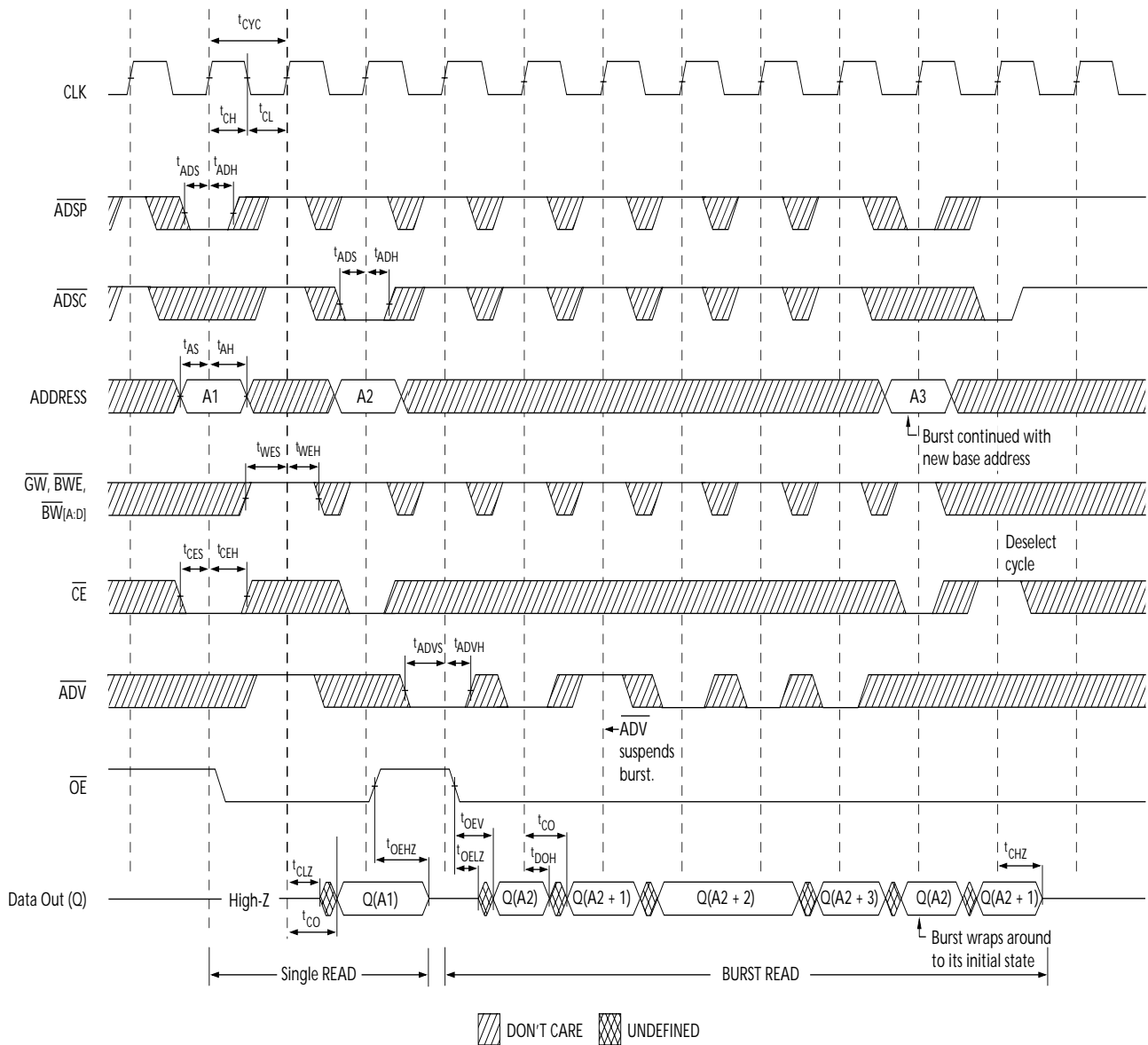
Switching Waveforms
Read Cycle Timing^[17]

Notes:

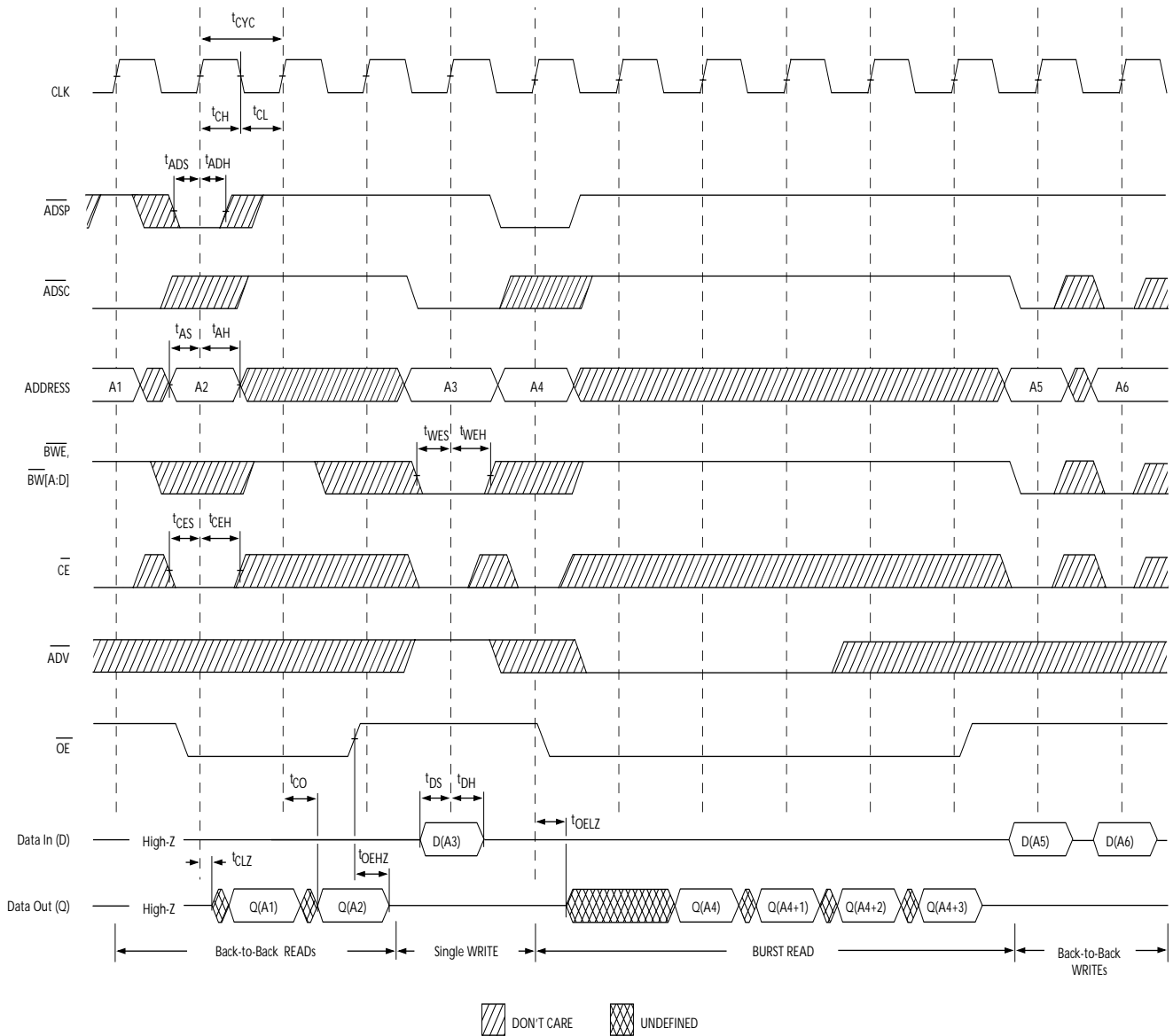
17. On this diagram when \overline{CE} is LOW, \overline{CE}_1 is LOW, CE_2 is HIGH and \overline{CE}_3 is LOW. When \overline{CE} is HIGH, \overline{CE}_1 is HIGH or CE_2 is LOW or \overline{CE}_3 is HIGH.
 18. Full width write can be initiated by either \overline{GW} LOW, or by \overline{GW} HIGH, \overline{BWE} LOW and $\overline{BW}_{[A:D]}$ LOW.

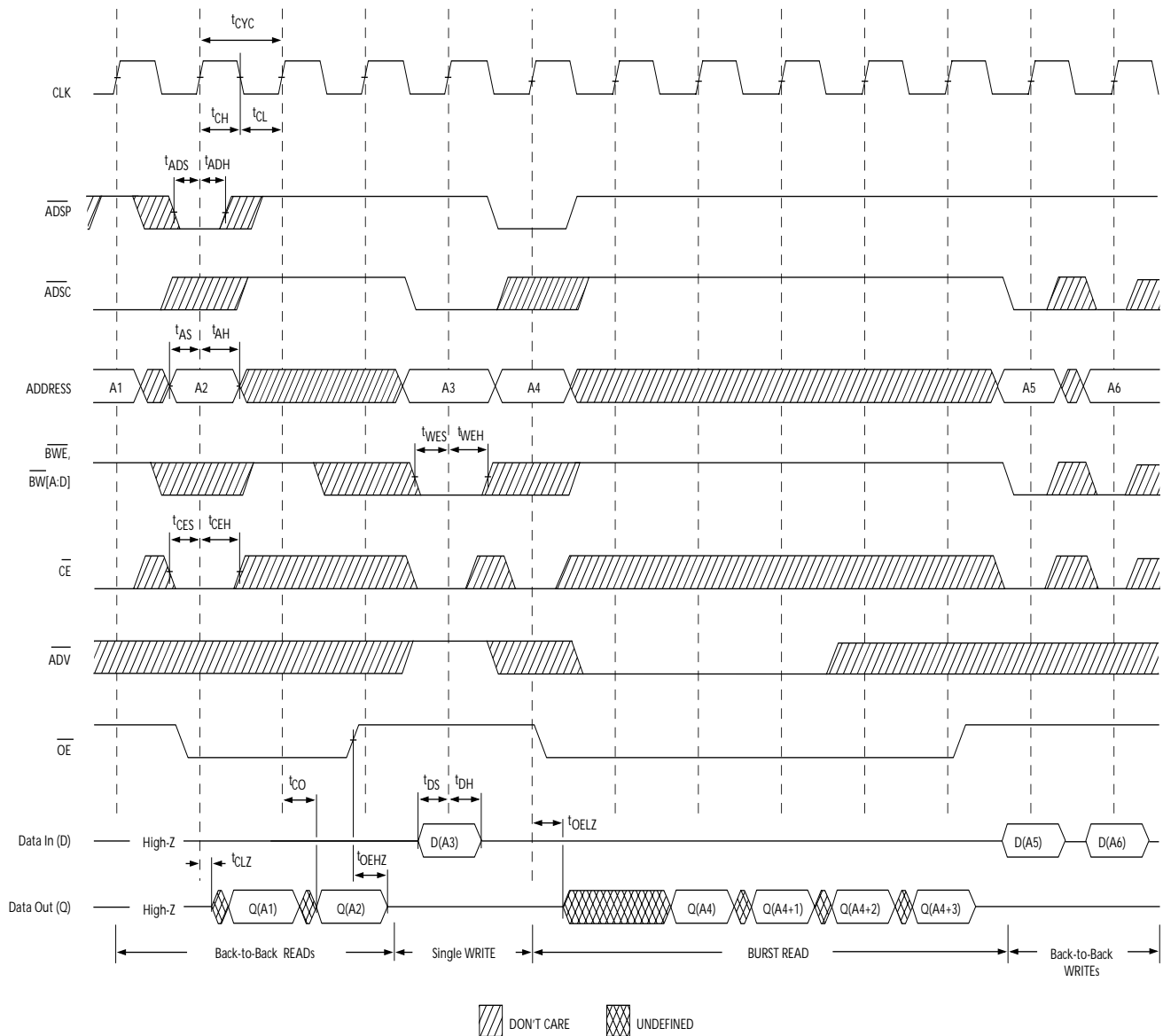
Switching Waveforms (continued)
Write Cycle Timing^[17, 18]

Switching Waveforms (continued)
Read/Write Cycle Timing^[17, 19, 20]

Note:
 19. The data bus (Q) remains in high-Z following a WRITE cycle, unless a new read access is initiated by \overline{ADSP} or \overline{ADSC} .
 20. GW is HIGH

Switching Waveforms (continued)

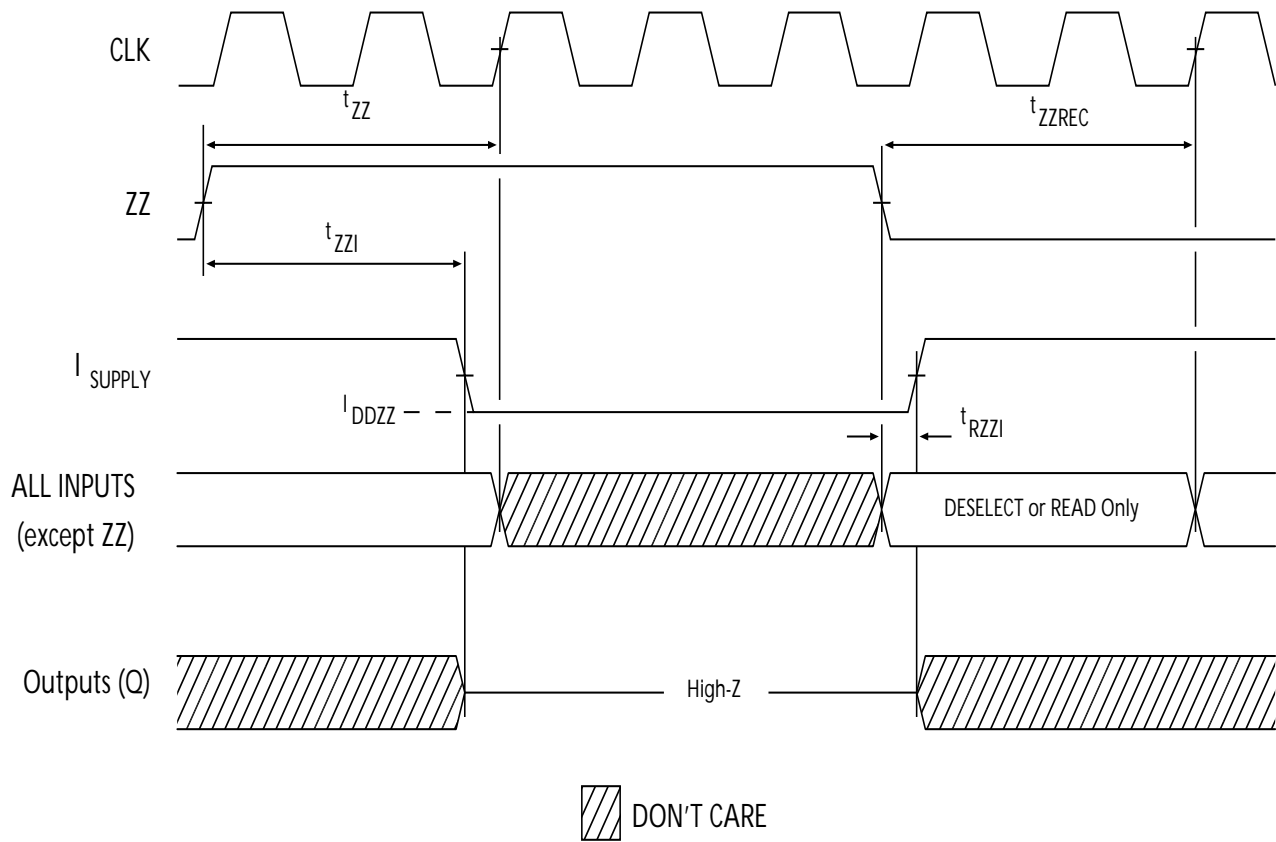
ZZ Mode Timing [21, 22]

Notes:

- 21. Device must be deselected when entering ZZ mode. See Cycle Descriptions table for all possible signal conditions to deselect the device.
- 22. DQs are in high-Z when exiting ZZ sleep mode.

Ordering Information

Speed (MHz)	Ordering Code	Package Name	Package Type	Operating Range
250	CY7C1347F-250AC	A101	100-Lead Thin Quad Flat Pack	Commercial
	CY7C1347F-250BGC	BG119	119-Ball BGA	
225	CY7C1347F-225AC	A101	100-Lead Thin Quad Flat Pack	Commercial
	CY7C1347F-225BGC	BG119	119-Ball BGA	
200	CY7C1347F-200AC	A101	100-Lead Thin Quad Flat Pack	Commercial
	CY7C1347F-200BGC	BG119	119-Ball BGA	
	CY7C1347F-200BZC	BB165C	165-Ball FBGA	
	CY7C1347F-200AI	A101	100-Lead Thin Quad Flat Pack	Industrial
	CY7C1347F-200BGI	BG119	119-Ball BGA	
166	CY7C1347F-166AC	A101	100-Lead Thin Quad Flat Pack	Commercial
	CY7C1347F-166BGC	BG119	119-Ball BGA	
	CY7C1347F-166BZC	BB165C	165-Ball FBGA	
	CY7C1347F-166AI	A101	100-Lead Thin Quad Flat Pack	Industrial
	CY7C1347F-166BGI	BG119	119-Ball BGA	
133	CY7C1347F-133AC	A101	100-Lead Thin Quad Flat Pack	Commercial
	CY7C1347F-133BGC	BG119	119-Ball BGA	
	CY7C1347F-133BZC	BB165C	165-Ball FBGA	
	CY7C1347F-133AI	A101	100-Lead Thin Quad Flat Pack	Industrial
	CY7C1347F-133BGI	BG119	119-Ball BGA	
100	CY7C1347F-100AC	A101	100-Lead Thin Quad Flat Pack	Commercial
	CY7C1347F-100BGC	BG119	119-Ball BGA	

Shaded areas contain advance information.

Please contact your local Cypress sales representative for availability of these parts.

Package Diagrams

100-Pin Thin Plastic Quad Flatpack (14 x 20 x 1.4 mm) A101

DIMENSIONS ARE IN MILLIMETERS.

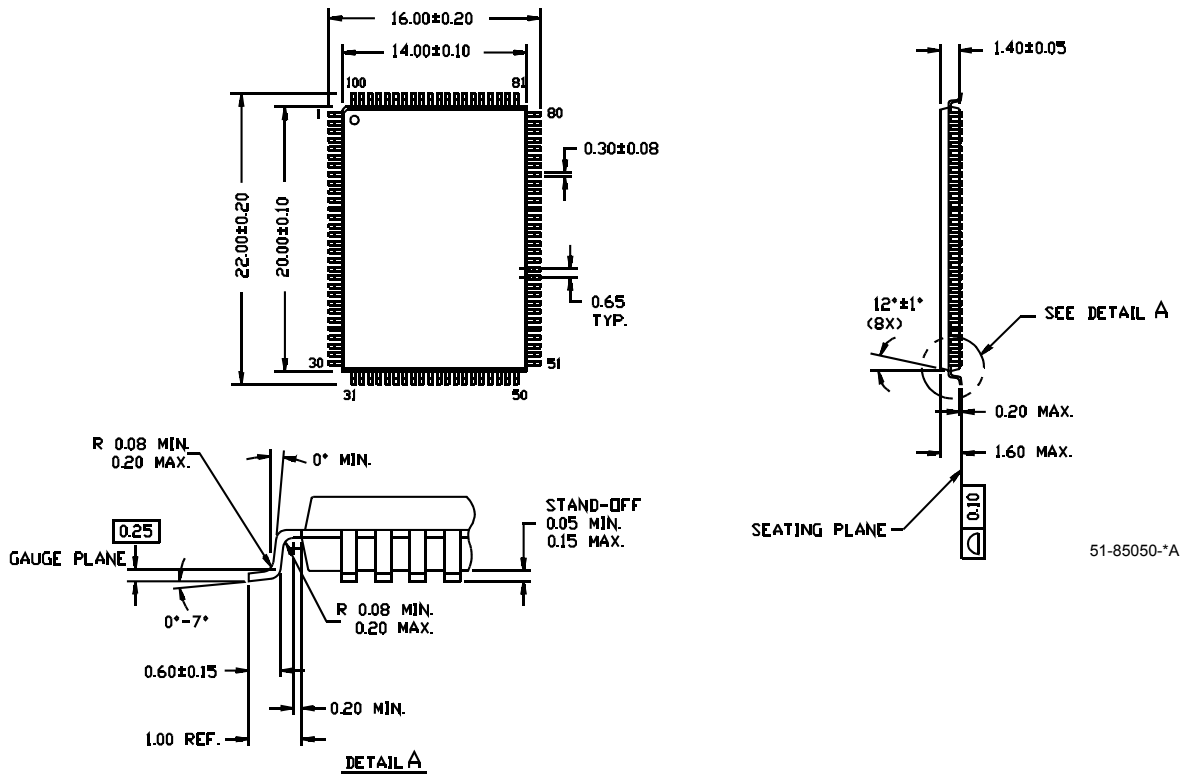

Package Diagrams (continued)

119-Lead PBGA (14 x 22 x 2.4 mm) BG119

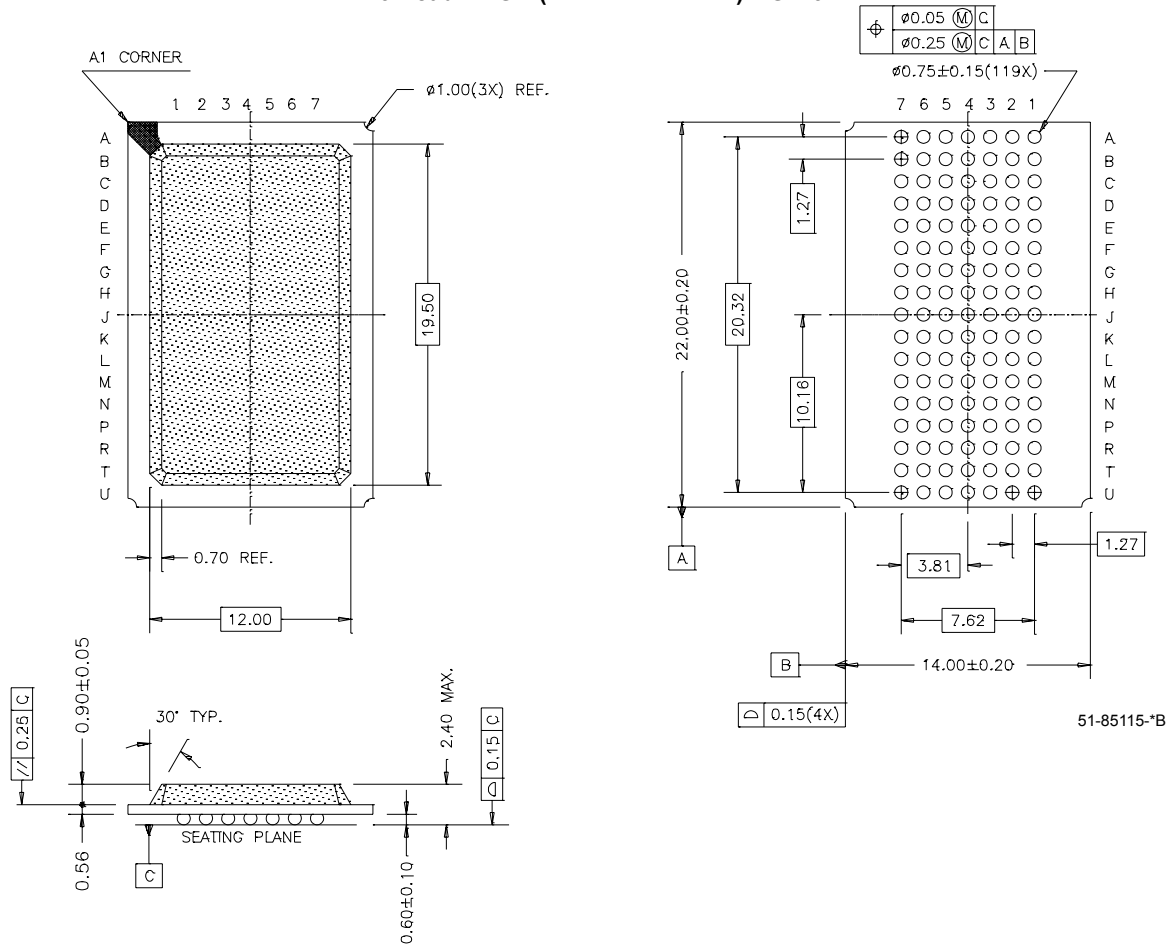

Package Diagrams (continued)

165-Ball FBGA (15 x 17 x 1.20 mm) BB165C

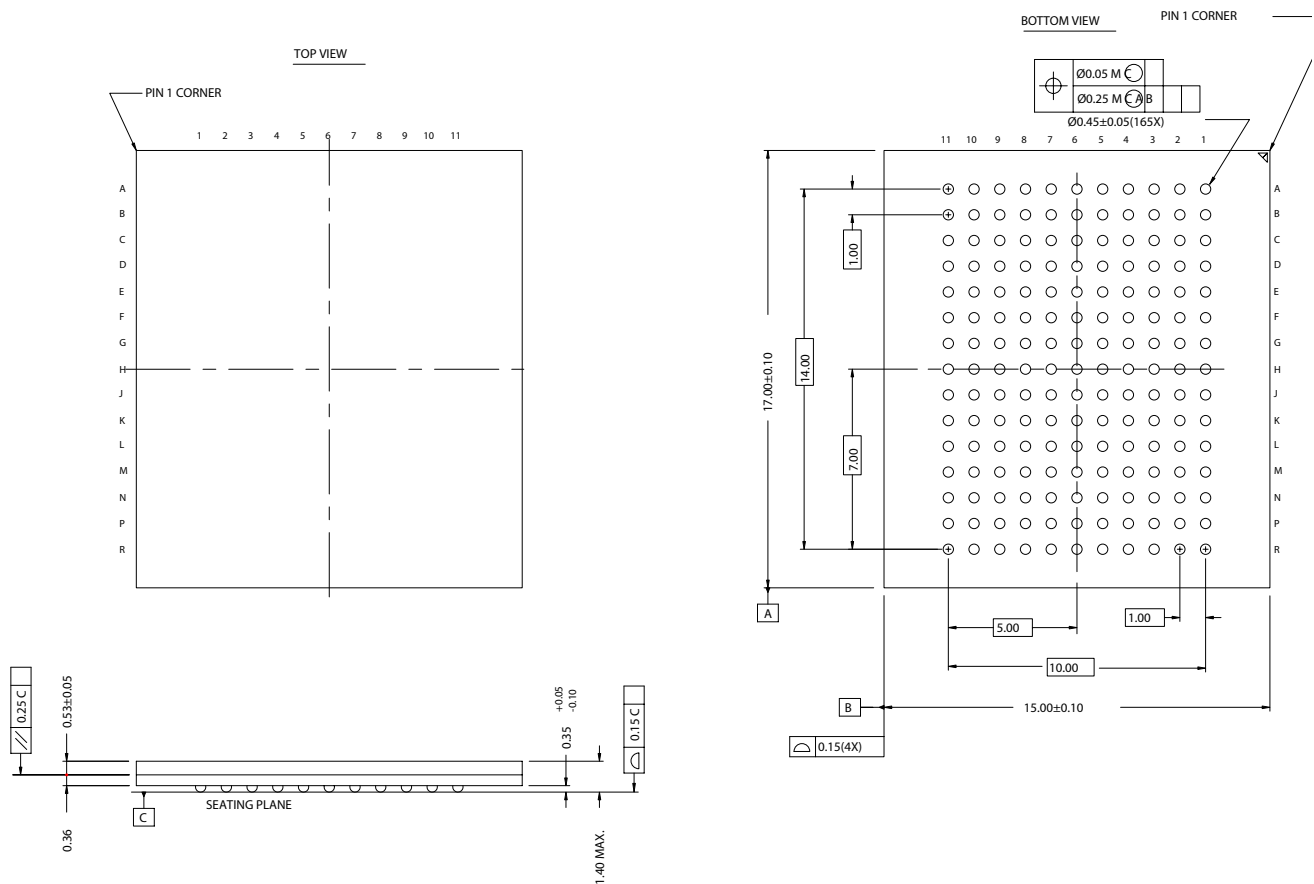

51-85165-*A



Intel and Pentium are registered trademarks of Intel Corporation. PowerPC is a registered trademark of International Business Machines, Inc. All product and company names mentioned in this document may be the trademarks of their respective holders.

Document History Page

Document Title: CY7C1347F 4-Mb (128K x 36) Pipelined Sync SRAM Document Number: 38-05213				
REV.	ECN NO.	Issue Date	Orig. of Change	Description of Change
**	119829	12/16/02	HGK	New Data Sheet
*A	123117	01/18/03	RBI	Added power-up requirements to AC test loads and waveforms information
*B	127632	06/13/03	DPM	Final Data Sheet
*C	200660	See ECN	SWI	Improvements: Updated thermal resistance and capacitance Updated R5 pin of 119-Ball BGA from V _{DD} to NC Updated all switching waveforms Clarifications: Updated footnotes Updated ZZ mode electrical characteristics

Looking for pricing, stock, or lifecycle information?

Click below to explore more details on WIN SOURCE:

-  [View CY7C1347F-133AC on WIN SOURCE](#)
-  [Cypress Semiconductor Corp Information](#)

Optimize Your Supply Chain with WIN SOURCE Solutions

-  Global Sourcing Solution
-  Obsolete Management
-  Cost Control Management
-  Shortage Management
-  Alternative Solution
-  Excess Inventory Management