



**THE DATASHEET OF  
CY7C131-25NC**



# 1 K x 8 Dual-Port Static RAM

## Features

- True dual-ported memory cells, which allow simultaneous reads of the same memory location
- 1 K x 8 organization
- 0.65 micron CMOS for optimum speed and power
- High speed access: 15 ns
- Low operating power:  $I_{CC} = 110$  mA (maximum)
- Fully asynchronous operation
- Automatic power-down
- Master CY7C130/130A/CY7C131/131A easily expands data bus width to 16 or more bits using slave CY7C140/CY7C141
- $\overline{BUSY}$  output flag on CY7C130/130A/CY7C131/131A;  $\overline{BUSY}$  input on CY7C140/CY7C141
- $\overline{INT}$  flag for port-to-port communication
- Available in 48-pin DIP (CY7C130/130A/140), 52-pin PLCC, 52-pin TQFP
- Pb-free packages available

## Functional Description

The CY7C130/130A/CY7C131/131A/CY7C140<sup>[1]</sup> and CY7C141 are high speed CMOS 1 K by 8 dual-port static RAMs. Two ports are provided permitting independent access to any location in memory. The CY7C130/130A/CY7C131/131A can be used as either a standalone 8-bit dual-port static RAM or as a master dual-port RAM in conjunction with the CY7C140/CY7C141 slave dual-port device in systems requiring 16-bit or greater word widths. It is the solution to applications requiring shared or buffered data, such as cache memory for DSP, bit-slice, or multi-processor designs.

Each port has independent control pins; chip enable ( $\overline{CE}$ ), write enable ( $R/\overline{W}$ ), and output enable ( $\overline{OE}$ ). Two flags are provided on each port,  $\overline{BUSY}$  and  $\overline{INT}$ .  $\overline{BUSY}$  signals that the port is trying to access the same location currently being accessed by the other port.  $\overline{INT}$  is an interrupt flag indicating that data is placed in a unique location (3FF for the left port and 3FE for the right port). An automatic power down feature is controlled independently on each port by the chip enable ( $\overline{CE}$ ) pins.

The CY7C130/130A and CY7C140 are available in 48-pin DIP. The CY7C131/131A and CY7C141 are available in 52-pin PLCC, 52-pin Pb-free PLCC, 52-pin PQFP, and 52-pin Pb-free PQFP.

## Logic Block Diagram

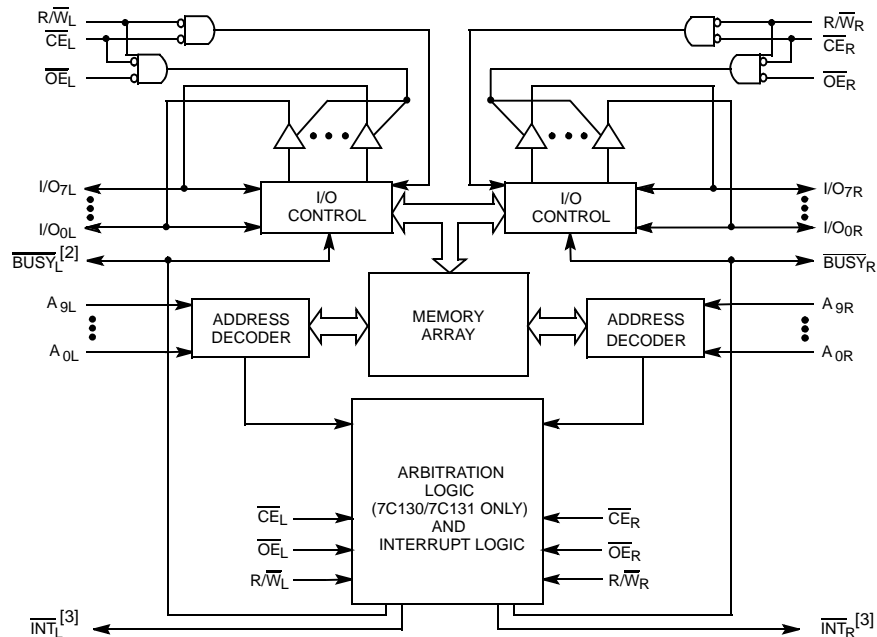

### Notes

1. CY7C130 and CY7C130A are functionally identical; CY7C131 and CY7C131A are functionally identical.
2. CY7C130/130A/CY7C131/131A (Master):  $\overline{BUSY}$  is open drain output and requires pull-up resistor.  
CY7C140/CY7C141 (Slave):  $\overline{BUSY}$  is input.
3. Open drain outputs: pull-up resistor required.

## Contents

<b>Pin Configurations</b> .....	<b>3</b>	<b>Ordering Information</b> .....	<b>17</b>
<b>Pin Definitions</b> .....	<b>4</b>	Ordering Code Definitions .....	17
<b>Selection Guide</b> .....	<b>4</b>	<b>Package Diagrams</b> .....	<b>18</b>
<b>Maximum Ratings</b> .....	<b>5</b>	<b>Acronyms</b> .....	<b>20</b>
<b>Operating Range</b> .....	<b>5</b>	<b>Document Conventions</b> .....	<b>20</b>
<b>Electrical Characteristics</b> .....	<b>5</b>	Units of Measure .....	20
<b>Capacitance</b> .....	<b>6</b>	<b>Document History Page</b> .....	<b>21</b>
<b>Switching Characteristics</b> .....	<b>7</b>	<b>Sales, Solutions, and Legal Information</b> .....	<b>22</b>
<b>Switching Characteristics</b> .....	<b>9</b>	Worldwide Sales and Design Support .....	22
<b>Switching Waveforms</b> .....	<b>11</b>	Products .....	22
<b>Typical DC and AC Characteristics</b> .....	<b>16</b>	PSoC Solutions .....	22

## Pin Configurations

Figure 1. Pin Diagram - DIP (Top View)

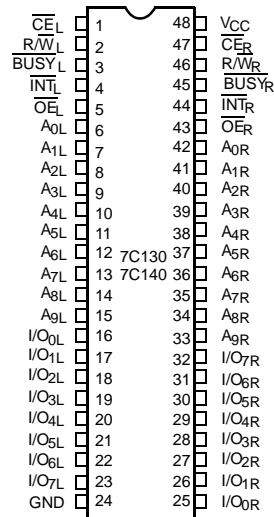

Figure 2. Pin Diagram - PLCC (Top View)

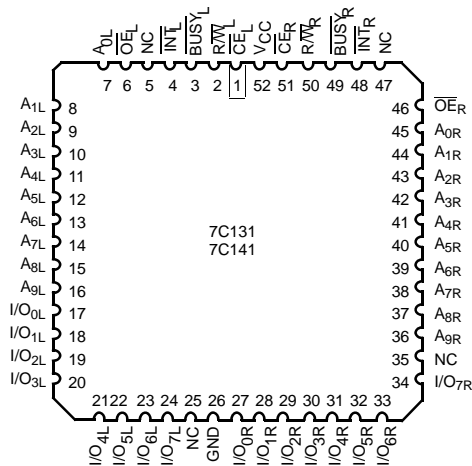
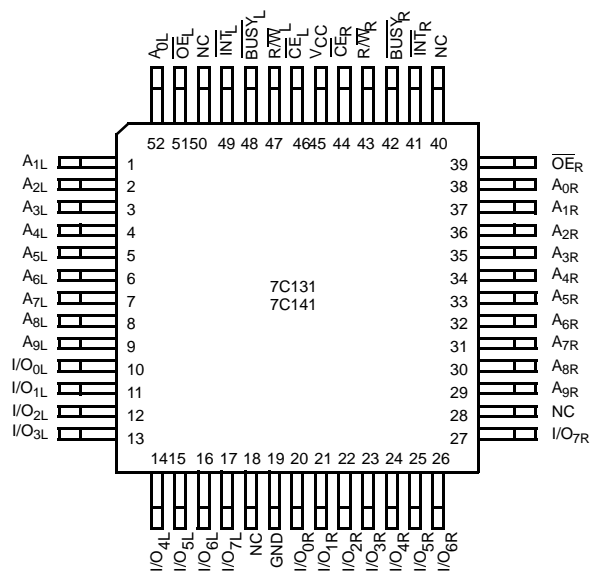

Figure 3. Pin Diagram - PQFP (Top View)



## Pin Definitions

Left Port	Right Port	Description
$\overline{CE}_L$	$\overline{CE}_R$	Chip enable
$R/\overline{W}_L$	$R/\overline{W}_R$	Read/write enable
$\overline{OE}_L$	$\overline{OE}_R$	Output enable
$A_{0L}-A_{11/12L}$	$A_{0R}-A_{11/12R}$	Address
$I/O_{0L}-I/O_{15/17L}$	$I/O_{0R}-I/O_{15/17R}$	Data bus input/output
$\overline{INT}_L$	$\overline{INT}_R$	Interrupt flag
$\overline{BUSY}_L$	$\overline{BUSY}_R$	Busy flag
$V_{CC}$		Power
GND		Ground

## Selection Guide

Parameter		7C131-15 <sup>[4]</sup> 7C131A-15 7C141-15	7C131-25 <sup>[4]</sup> 7C141-25	7C130-30 7C130A-30 7C131-30 7C140-30 7C141-30	7C130-35 7C131-35 7C140-35 7C141-35	7C130-45 7C131-45 7C140-45 7C141-45	7C130-55 7C131-55 7C140-55 7C141-55	Unit
Maximum access time		15	25	30	35	45	55	ns
Maximum operating current	Commercial/ Industrial	190	170	170	120	120	110	mA
Maximum standby current	Commercial/ Industrial	75	65	65	45	45	35	mA

Shaded areas contain preliminary information.

### Note

4. 15 and 25 ns version available only in PLCC/PQFP packages.



**Maximum Ratings<sup>[5]</sup>**

Exceeding maximum ratings may shorten the useful life of the device. User guidelines are not tested.

- Storage temperature ..... -65 °C to +150 °C
- Ambient temperature with power applied ..... -55 °C to +125 °C
- Supply voltage to ground potential (pin 48 to pin 24).....-0.5 V to +7.0 V
- DC voltage applied to outputs in high Z State.....-0.5 V to +7.0 V

- DC input voltage .....-3.5 V to +7.0 V
- Output current into outputs (LOW) ..... 20 mA
- Static discharge voltage..... > 2001 V (per MIL-STD-883, method 3015)
- Latch-up current ..... > 200 mA

**Operating Range**

Range	Ambient Temperature	V <sub>CC</sub>
Commercial	0 °C to +70 °C	5 V ± 10%
Industrial	-40 °C to +85 °C	5 V ± 10%
Military <sup>[6]</sup>	-55 °C to +125 °C	5 V ± 10%

**Electrical Characteristics**

Over the Operating Range<sup>[7]</sup>

Parameter	Description	Test Conditions	7C131-15 <sup>[4]</sup> 7C131A-15 7C141-15		7C130-30 <sup>[4]</sup> 7C130A-30 7C131-25,30 7C140-30 7C141-25,30		7C130-35,45 7C131-35,45 7C140-35,45 7C141-35,45		7C130-55 7C131-55 7C140-55 7C141-55		Unit	
			Min	Max	Min	Max	Min	Max	Min	Max		
V <sub>OH</sub>	Output HIGH voltage	V <sub>CC</sub> = Min, I <sub>OH</sub> = -4.0 mA	2.4	-	2.4	-	2.4	-	2.4	-	V	
V <sub>OL</sub>	Output LOW voltage	I <sub>OL</sub> = 4.0 mA	-	0.4	-	0.4	-	0.4	-	0.4	V	
		I <sub>OL</sub> = 16.0 mA <sup>[8]</sup>	-	0.5	-	0.5	-	0.5	-	0.5	V	
V <sub>IH</sub>	Input HIGH voltage		2.2	-	2.2	-	2.2	-	2.2	-	V	
V <sub>IL</sub>	Input LOW voltage		-	0.8	-	0.8	-	0.8	-	0.8	V	
I <sub>IX</sub>	Input leakage current	GND ≤ V <sub>I</sub> ≤ V <sub>CC</sub>	-5	+5	-5	+5	-5	+5	-5	+5	µA	
I <sub>OZ</sub>	Output leakage current	GND ≤ V <sub>O</sub> ≤ V <sub>CC</sub> , output disabled	-5	+5	-5	+5	-5	+5	-5	+5	µA	
I <sub>OS</sub>	Output short circuit current <sup>[9, 10]</sup>	V <sub>CC</sub> = Max, V <sub>OUT</sub> = GND	-	-350	-	-350	-	-350	-	-350	mA	
I <sub>CC</sub>	V <sub>CC</sub> operating supply current	CE = V <sub>IL</sub> , outputs open, f = f <sub>MAX</sub> <sup>[11]</sup>	Commercial	-	190	-	170	-	120	-	110	mA
I <sub>SB1</sub>	Standby current both ports, TTL inputs	CE <sub>L</sub> and CE <sub>R</sub> ≥ V <sub>IH</sub> , f = f <sub>MAX</sub> <sup>[11]</sup>	Commercial	-	75	-	65	-	45	-	35	mA
I <sub>SB2</sub>	Standby current one port, TTL inputs	CE <sub>L</sub> or CE <sub>R</sub> ≥ V <sub>IH</sub> , active port outputs open, f = f <sub>MAX</sub> <sup>[11]</sup>	Commercial	-	135	-	115	-	90	-	75	mA
I <sub>SB3</sub>	Standby current both ports, CMOS inputs	Both ports CE <sub>L</sub> and CE <sub>R</sub> ≥ V <sub>CC</sub> - 0.2 V, V <sub>IN</sub> ≥ V <sub>CC</sub> - 0.2 V or V <sub>IN</sub> ≤ 0.2 V, f = 0	Commercial	-	15	-	15	-	15	-	15	mA
I <sub>SB4</sub>	Standby current one port, CMOS inputs	One port CE <sub>L</sub> or CE <sub>R</sub> ≥ V <sub>CC</sub> - 0.2 V, V <sub>IN</sub> ≥ V <sub>CC</sub> - 0.2 V or V <sub>IN</sub> ≤ 0.2 V, active port outputs open, f = f <sub>MAX</sub> <sup>[11]</sup>	Commercial	-	125	-	105	-	85	-	70	mA

Shaded areas contain preliminary information.

**Notes**

5. The voltage on any input or I/O pin cannot exceed the power pin during power up.
6. T<sub>A</sub> is the "instant on" case temperature
7. See the last page of this specification for Group A subgroup testing information.
8. BUSY and INT pins only.
9. Duration of the short circuit should not exceed 30 seconds.
10. This parameter is guaranteed but not tested.
11. At f = f<sub>MAX</sub>, address and data inputs are cycling at the maximum frequency of read cycle of 1/t<sub>RC</sub> and using AC Test Waveforms input levels of GND to 3 V.

**Capacitance<sup>[10]</sup>**

Parameter	Description	Test Conditions	Max	Unit
$C_{IN}$	Input capacitance	$T_A = 25\text{ }^\circ\text{C}$ , $f = 1\text{ MHz}$ , $V_{CC} = 5.0\text{ V}$	15	pF
$C_{OUT}$	Output capacitance		10	pF

**Figure 4. AC Test Loads and Waveforms**

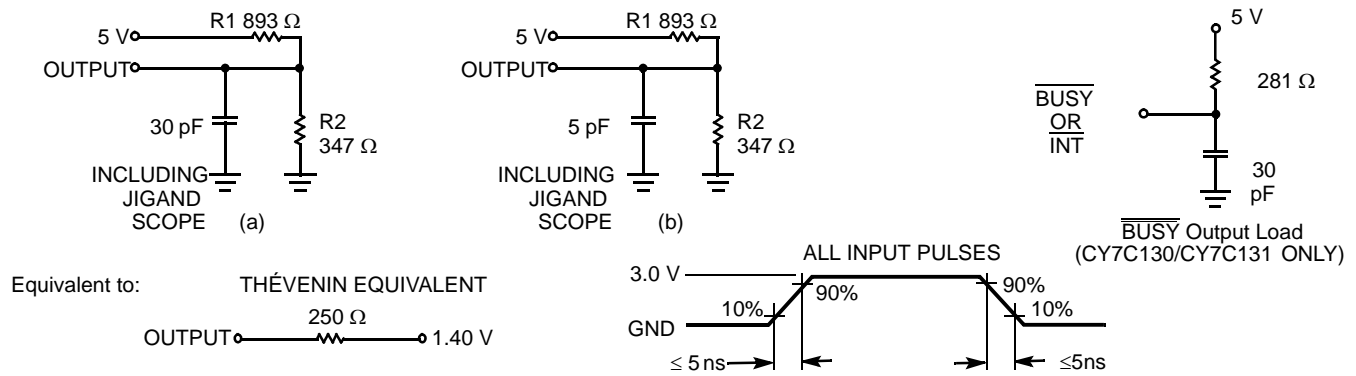

## Switching Characteristics

Over the Operating Range<sup>[12, 13]</sup>

Parameter	Description	7C131-15 <sup>[14]</sup> 7C131A-15 7C141-15		7C130-25 <sup>[14]</sup> 7C131-25 7C140-25 7C141-25		7C130-30 7C130A-30 7C131-30 7C140-30 7C141-30		Unit
		Min	Max	Min	Max	Min	Max	
<b>Read Cycle</b>								
t <sub>RC</sub>	Read cycle time	15	–	25	–	30	–	ns
t <sub>AA</sub>	Address to data valid <sup>[15]</sup>	–	15	–	25	–	30	ns
t <sub>OHA</sub>	Data hold from address change	0	–	0	–	0	–	ns
t <sub>ACE</sub>	CE LOW to data valid <sup>[15]</sup>	–	15	–	25	–	30	ns
t <sub>DOE</sub>	OE LOW to data valid <sup>[15]</sup>	–	10	–	15	–	20	ns
t <sub>LZOE</sub>	OE LOW to low Z <sup>[16, 17, 18]</sup>	3	–	3	–	3	–	ns
t <sub>HZOE</sub>	OE HIGH to high Z <sup>[16, 17, 18]</sup>	–	10	–	15	–	15	ns
t <sub>LZCE</sub>	CE LOW to low Z <sup>[16, 17, 18]</sup>	3	–	5	–	5	–	ns
t <sub>HZCE</sub>	CE HIGH to high Z <sup>[16, 17, 18]</sup>	–	10	–	15	–	15	ns
t <sub>PU</sub>	CE LOW to power-up <sup>[16]</sup>	0	–	0	–	0	–	ns
t <sub>PD</sub>	CE HIGH to power-down <sup>[16]</sup>	–	15	–	25	–	25	ns
<b>Write Cycle<sup>[19]</sup></b>								
t <sub>WC</sub>	Write cycle time	15	–	25	–	30	–	ns
t <sub>SCE</sub>	CE LOW to write end	12	–	20	–	25	–	ns
t <sub>AW</sub>	Address setup to write end	12	–	20	–	25	–	ns
t <sub>HA</sub>	Address hold from write end	2	–	2	–	2	–	ns
t <sub>SA</sub>	Address setup to write start	0	–	0	–	0	–	ns
t <sub>PWE</sub>	R/W pulse width	12	–	15	–	25	–	ns
t <sub>SD</sub>	Data setup to write end	10	–	15	–	15	–	ns
t <sub>HD</sub>	Data hold from write end	0	–	0	–	0	–	ns
t <sub>HZWE</sub>	R/W LOW to high Z <sup>[18]</sup>	–	10	–	15	–	15	ns
t <sub>LZWE</sub>	R/W HIGH to low Z <sup>[18]</sup>	0	–	0	–	0	–	ns

Shaded areas contain preliminary information.

### Notes

- See the last page of this specification for Group A subgroup testing information.
- Test conditions assume signal transition times of 5 ns or less, timing reference levels of 1.5 V, input pulse levels of 0 to 3.0 V and output loading of the specified I<sub>OL</sub>/I<sub>OH</sub> and 30 pF load capacitance.
- 15 and 25 ns version available only in PLCC/PQFP packages.
- AC Test Conditions use V<sub>OH</sub> = 1.6 V and V<sub>OL</sub> = 1.4 V.
- This parameter is guaranteed but not tested.
- At any given temperature and voltage condition for any given device, t<sub>HZCE</sub> is less than t<sub>LZCE</sub> and t<sub>HZOE</sub> is less than t<sub>LZOE</sub>.
- t<sub>LZCE</sub>, t<sub>LZWE</sub>, t<sub>HZOE</sub>, t<sub>LZOE</sub>, t<sub>HZCE</sub> and t<sub>HZWE</sub> are tested with C<sub>L</sub> = 5 pF as in part (b) of AC Test Loads. Transition is measured ±500 mV from steady state voltage.
- The internal write time of the memory is defined by the overlap of CS LOW and R/W LOW. Both signals must be low to initiate a write and either signal can terminate a write by going high. The data input setup and hold timing should be referenced to the rising edge of the signal that terminates the write.

## Switching Characteristics

Over the Operating Range<sup>[12, 13]</sup> (continued)

Parameter	Description	7C131-15 <sup>[14]</sup> 7C131A-15 7C141-15		7C130-25 <sup>[14]</sup> 7C131-25 7C140-25 7C141-25		7C130-30 7C130A-30 7C131-30 7C140-30 7C141-30		Unit
		Min	Max	Min	Max	Min	Max	
<b>Busy/Interrupt Timing</b>								
t <sub>BLA</sub>	BUSY LOW from address match	–	15	–	20	–	20	ns
t <sub>BHA</sub>	BUSY HIGH from address mismatch <sup>[20]</sup>	–	15	–	20	–	20	ns
t <sub>BLC</sub>	BUSY LOW from CE LOW	–	15	–	20	–	20	ns
t <sub>BHC</sub>	BUSY HIGH from CE HIGH <sup>[20]</sup>	–	15	–	20	–	20	ns
t <sub>PS</sub>	Port set-up for priority	5	–	5	–	5	–	ns
t <sub>WB</sub> <sup>[21]</sup>	R/W LOW after BUSY LOW	0	–	0	–	0	–	ns
t <sub>WH</sub>	R/W HIGH after BUSY HIGH	13	–	20	–	30	–	ns
t <sub>BDD</sub>	BUSY HIGH to valid data	–	15	–	25	–	30	ns
t <sub>DDD</sub>	Write data valid to read data valid	–	Note 22	–	Note 22	–	Note 22	ns
t <sub>WDD</sub>	Write pulse to data delay	–	Note 22	–	Note 22	–	Note 22	ns
<b>Interrupt Timing</b>								
t <sub>WINS</sub>	R/W to INTERRUPT set time	–	15	–	25	–	25	ns
t <sub>EINS</sub>	CE to INTERRUPT set time	–	15	–	25	–	25	ns
t <sub>INS</sub>	Address to INTERRUPT set time	–	15	–	25	–	25	ns
t <sub>OINR</sub>	OE to INTERRUPT reset time <sup>[20]</sup>	–	15	–	25	–	25	ns
t <sub>EINR</sub>	CE to INTERRUPT reset time <sup>[20]</sup>	–	15	–	25	–	25	ns
t <sub>INR</sub>	Address to INTERRUPT reset time <sup>[20]</sup>	–	15	–	25	–	25	ns

Shaded areas contain preliminary information.

### Notes

20. These parameters are measured from the input signal changing, until the output pin goes to a high-impedance state.

21. CY7C140/CY7C141 only.

22. A write operation on Port A, where Port A has priority, leaves the data on Port B's outputs undisturbed until one access time after one of the following:

BUSY on Port B goes HIGH.

Port B's address is toggled.

CE for Port B is toggled.

R/W for Port B is toggled during valid read.

## Switching Characteristics

Over the Operating Range<sup>[23, 24]</sup>

Parameter	Description	7C130-35 7C131-35 7C140-35 7C141-35		7C130-45 7C131-45 7C140-45 7C141-45		7C130-55 7C131-55 7C140-55 7C141-55		Unit
		Min	Max	Min	Max	Min	Max	
<b>Read Cycle</b>								
t <sub>RC</sub>	Read cycle time	35	–	45	–	55	–	ns
t <sub>AA</sub>	Address to data valid <sup>[25]</sup>	–	35	–	45	–	55	ns
t <sub>OHA</sub>	Data hold from address change	0	–	0	–	0	–	ns
t <sub>ACE</sub>	CE LOW to data valid <sup>[25]</sup>	–	35	–	45	–	55	ns
t <sub>DOE</sub>	OE LOW to data valid <sup>[25]</sup>	–	20	–	25	–	25	ns
t <sub>LZOE</sub>	OE LOW to low Z <sup>[26, 27, 28]</sup>	3	–	3	–	3	–	ns
t <sub>HZOE</sub>	OE HIGH to high Z <sup>[26, 27, 28]</sup>	–	20	–	20	–	25	ns
t <sub>LZCE</sub>	CE LOW to low Z <sup>[26, 27, 28]</sup>	5	–	5	–	5	–	ns
t <sub>HZCE</sub>	CE HIGH to high Z <sup>[26, 27, 28]</sup>	–	20	–	20	–	25	ns
t <sub>PU</sub>	CE LOW to power-up <sup>[26]</sup>	0	–	0	–	0	–	ns
t <sub>PD</sub>	CE HIGH to power-down <sup>[26]</sup>	–	35	–	35	–	35	ns
<b>Write Cycle</b> <sup>[29]</sup>								
t <sub>WC</sub>	Write cycle time	35	–	45	–	55	–	ns
t <sub>SCE</sub>	CE LOW to write end	30	–	35	–	40	–	ns
t <sub>AW</sub>	Address set-up to write end	30	–	35	–	40	–	ns
t <sub>HA</sub>	Address hold from write end	2	–	2	–	2	–	ns
t <sub>SA</sub>	Address set-up to write start	0	–	0	–	0	–	ns
t <sub>PWE</sub>	R/W pulse width	25	–	30	–	30	–	ns
t <sub>SD</sub>	Data set-up to write end	15	–	20	–	20	–	ns
t <sub>HD</sub>	Data hold from write end	0	–	0	–	0	–	ns
t <sub>HZWE</sub>	R/W LOW to high Z <sup>[28]</sup>	–	20	–	20	–	25	ns
t <sub>LZWE</sub>	R/W HIGH to low Z <sup>[28]</sup>	0	–	0	–	0	–	ns

### Notes

23. See the last page of this specification for Group A subgroup testing information.

24. Test conditions assume signal transition times of 5 ns or less, timing reference levels of 1.5 V, input pulse levels of 0 to 3.0 V and output loading of the specified I<sub>OL</sub>/I<sub>OH</sub> and 30 pF load capacitance.

25. AC Test Conditions use V<sub>OH</sub> = 1.6 V and V<sub>OL</sub> = 1.4 V.

26. This parameter is guaranteed but not tested.

27. At any given temperature and voltage condition for any given device, t<sub>HZCE</sub> is less than t<sub>LZCE</sub> and t<sub>HZOE</sub> is less than t<sub>LZOE</sub>.

28. t<sub>LZCE</sub>, t<sub>LZWE</sub>, t<sub>HZOE</sub>, t<sub>LZOE</sub>, t<sub>HZCE</sub> and t<sub>HZWE</sub> are tested with C<sub>L</sub> = 5 pF as in part (b) of AC Test Loads. Transition is measured ±500 mV from steady state voltage.

29. The internal write time of the memory is defined by the overlap of CS LOW and R/W LOW. Both signals must be low to initiate a write and either signal can terminate a write by going high. The data input setup and hold timing should be referenced to the rising edge of the signal that terminates the write.

## Switching Characteristics

Over the Operating Range<sup>[23, 24]</sup> (continued)

Parameter	Description	7C130-35 7C131-35 7C140-35 7C141-35		7C130-45 7C131-45 7C140-45 7C141-45		7C130-55 7C131-55 7C140-55 7C141-55		Unit
		Min	Max	Min	Max	Min	Max	
<b>Busy/Interrupt Timing</b>								
t <sub>BLA</sub>	BUSY LOW from address match	–	20	–	25	–	30	ns
t <sub>BHA</sub>	BUSY HIGH from address mismatch <sup>[30]</sup>	–	20	–	25	–	30	ns
t <sub>BLC</sub>	BUSY LOW from CE LOW	–	20	–	25	–	30	ns
t <sub>BHC</sub>	BUSY HIGH from CE HIGH <sup>[30]</sup>	–	20	–	25	–	30	ns
t <sub>PS</sub>	Port set-up for priority	5	–	5	–	5	–	ns
t <sub>WB</sub> <sup>[31]</sup>	R/W LOW after BUSY LOW	0	–	0	–	0	–	ns
t <sub>WH</sub>	R/W HIGH after BUSY HIGH	30	–	35	–	35	–	ns
t <sub>BDD</sub>	BUSY HIGH to valid data	–	35	–	45	–	45	ns
t <sub>DDD</sub>	Write data valid to read data valid	–	Note 32	–	Note 32	–	Note 32	ns
t <sub>WDD</sub>	Write pulse to data delay	–	Note 32	–	Note 32	–	Note 32	ns
<b>Interrupt Timing</b>								
t <sub>WINS</sub>	R/W to INTERRUPT set time	–	25	–	35	–	45	ns
t <sub>EINS</sub>	CE to INTERRUPT set time	–	25	–	35	–	45	ns
t <sub>INS</sub>	Address to INTERRUPT set time	–	25	–	35	–	45	ns
t <sub>OINR</sub>	OE to INTERRUPT reset time <sup>[20]</sup>	–	25	–	35	–	45	ns
t <sub>EINR</sub>	CE to INTERRUPT reset time <sup>[20]</sup>	–	25	–	35	–	45	ns
t <sub>INR</sub>	Address to INTERRUPT reset time <sup>[20]</sup>	–	25	–	35	–	45	ns

### Notes

30. These parameters are measured from the input signal changing, until the output pin goes to a high-impedance state.

31. CY7C140/CY7C141 only.

32. A write operation on Port A, where Port A has priority, leaves the data on Port B's outputs undisturbed until one access time after one of the following:

BUSY on Port B goes HIGH.

Port B's address is toggled.

CE for Port B is toggled.

R/W for Port B is toggled during valid read.

## Switching Waveforms

**Figure 5. Read Cycle No. 1**<sup>[33, 34]</sup>

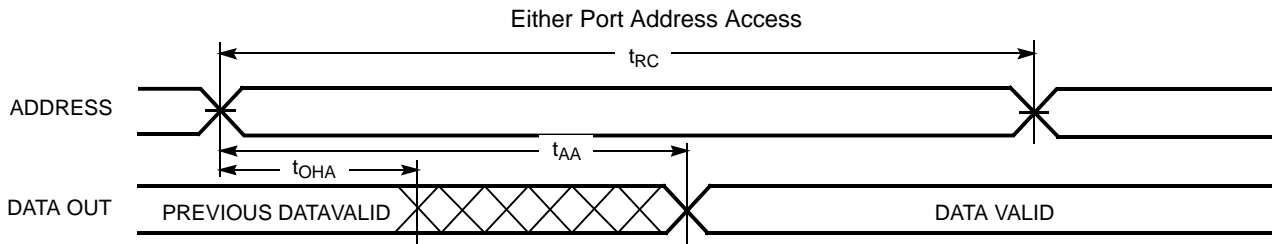

**Figure 6. Read Cycle No. 2**<sup>[33, 35]</sup>

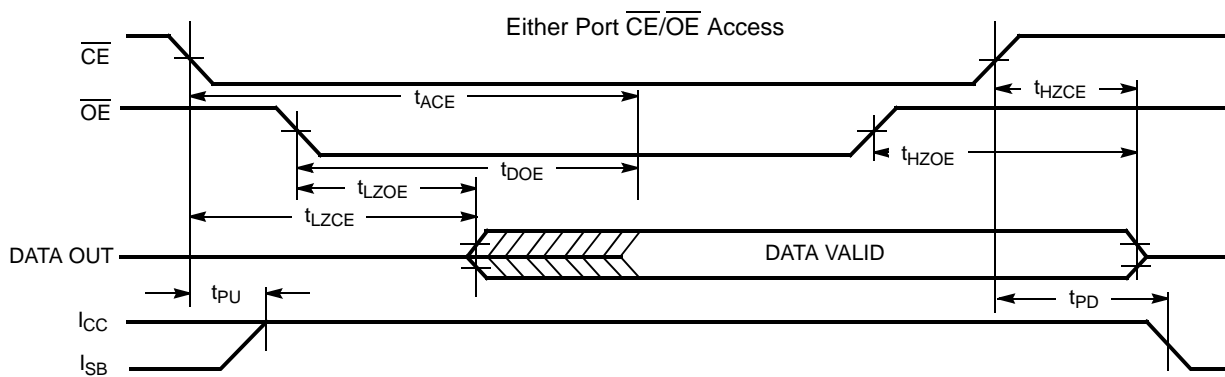

**Figure 7. Read Cycle No. 3**<sup>[34]</sup>

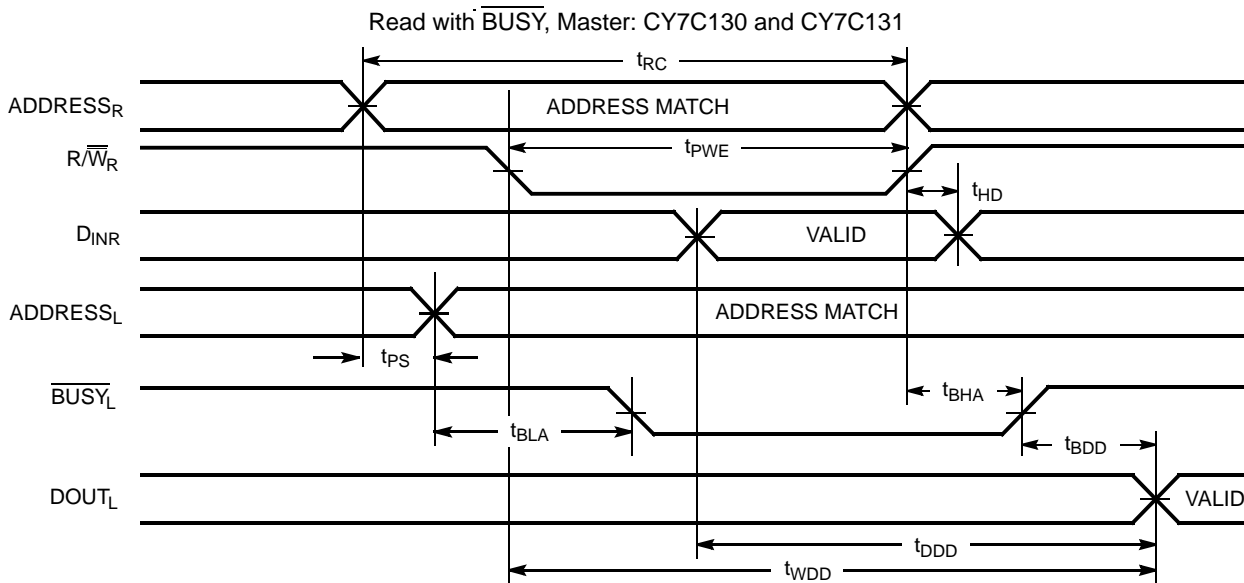

### Notes

- 33.  $\overline{RW}$  is HIGH for read cycle.
- 34. Device is continuously selected,  $\overline{CE} = V_{IL}$  and  $\overline{OE} = V_{IL}$ .
- 35. Address valid prior to or coincident with  $\overline{CE}$  transition LOW.

**Switching Waveforms** (continued)

**Figure 8. Write Cycle No. 1 (OE Three-States Data I/Os—Either Port)**<sup>[36, 37]</sup>

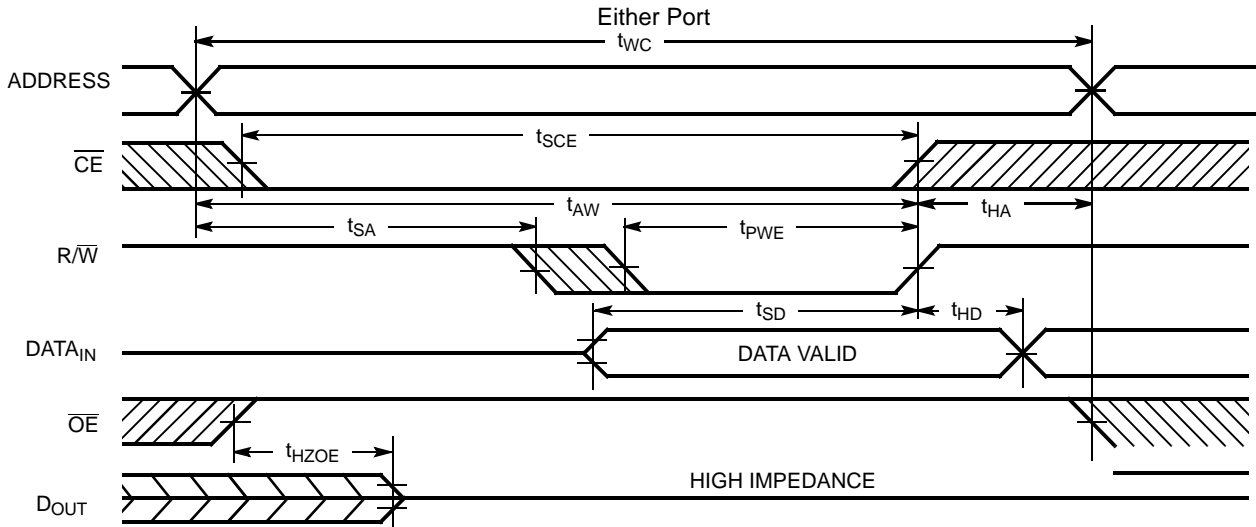

**Figure 9. Write Cycle No. 2 (R/W Three-States Data I/Os—Either Port)**<sup>[38, 39]</sup>

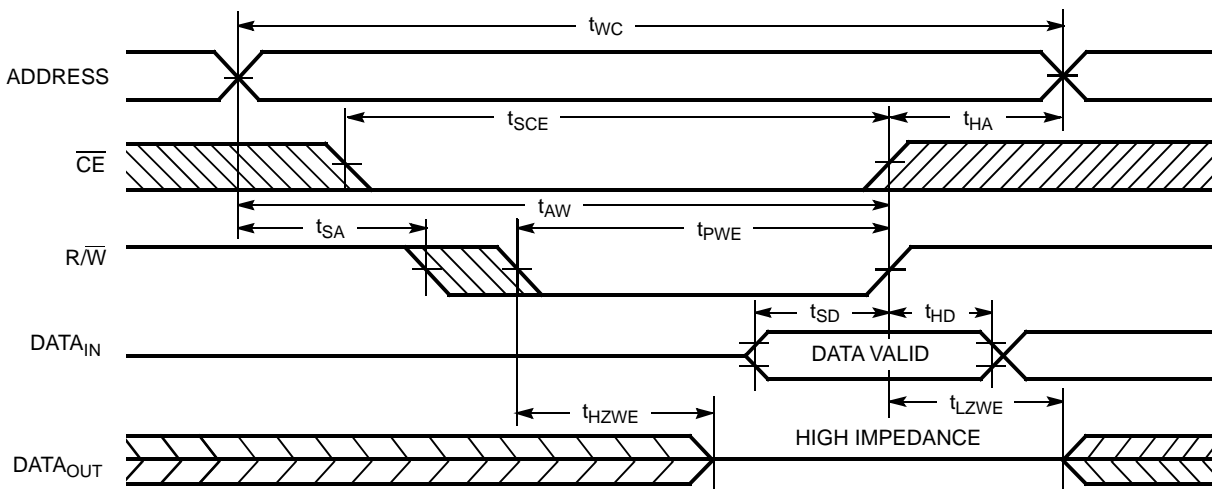

**Notes**

- 36. The internal write time of the memory is defined by the overlap of  $\overline{CS}$  LOW and  $\overline{R/W}$  LOW. Both signals must be low to initiate a write and either signal can terminate a write by going high. The data input setup and hold timing should be referenced to the rising edge of the signal that terminates the write.
- 37. If  $\overline{OE}$  is LOW during a  $\overline{R/W}$  controlled write cycle, the write pulse width must be the larger of  $t_{PWE}$  or  $t_{HZWE} + t_{SD}$  to allow the data I/O pins to enter high impedance and for data to be placed on the bus for the required  $t_{SD}$ .
- 38. These parameters are measured from the input signal changing, until the output pin goes to a high-impedance state.
- 39. If the  $\overline{CE}$  LOW transition occurs simultaneously with or after the  $\overline{R/W}$  LOW transition, the outputs remain in the high impedance state.

Switching Waveforms (continued)

Figure 10. Busy Timing Diagram No. 1 ( $\overline{CE}$  Arbitration)

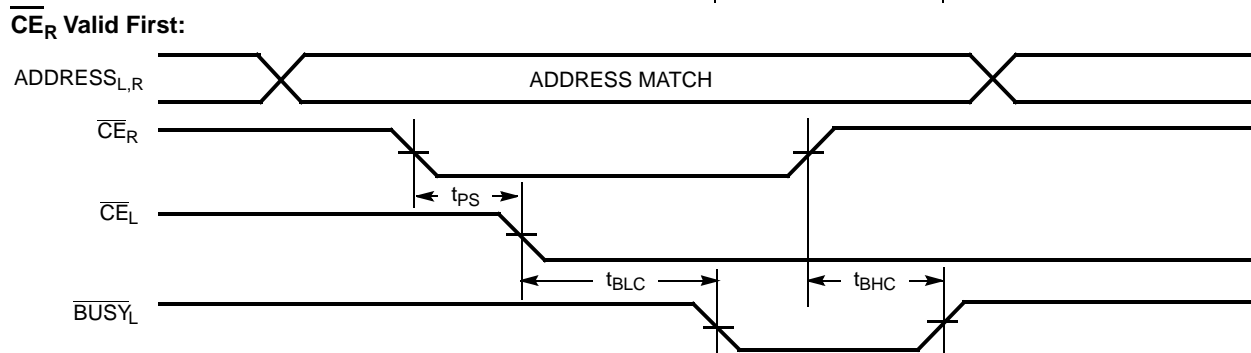
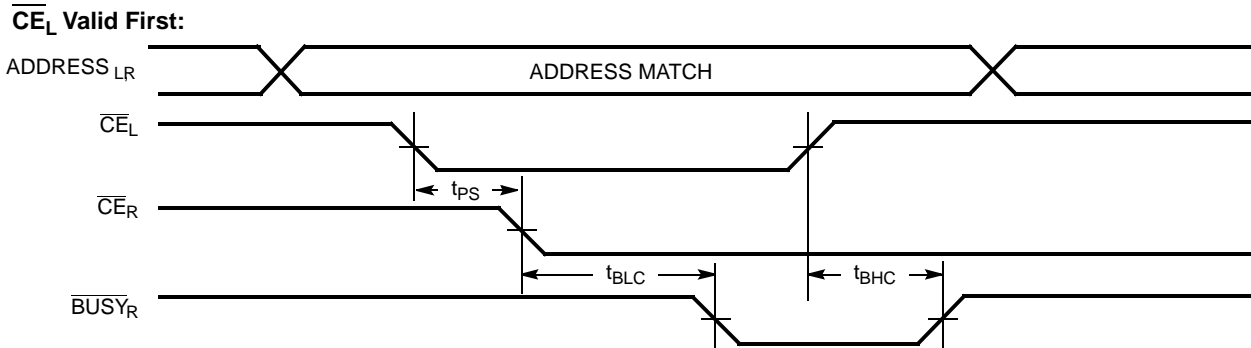
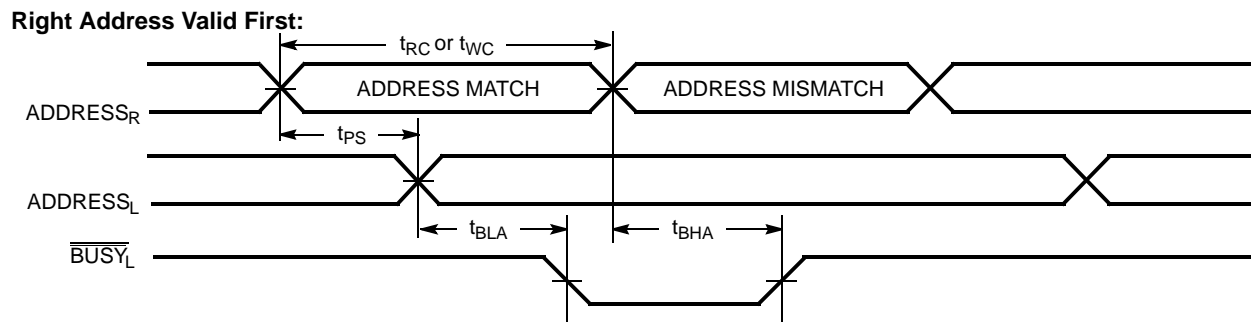
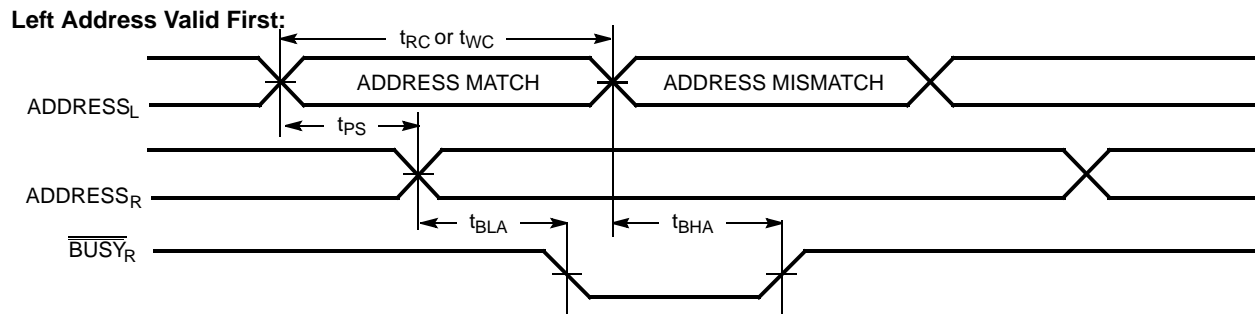

Figure 11. Busy Timing Diagram No. 2 (Address Arbitration)



**Switching Waveforms** *(continued)*

**Figure 12. Busy Timing Diagram No. 3**

Write with  $\overline{\text{BUSY}}$  (Slave:CY7C140/CY7C141)

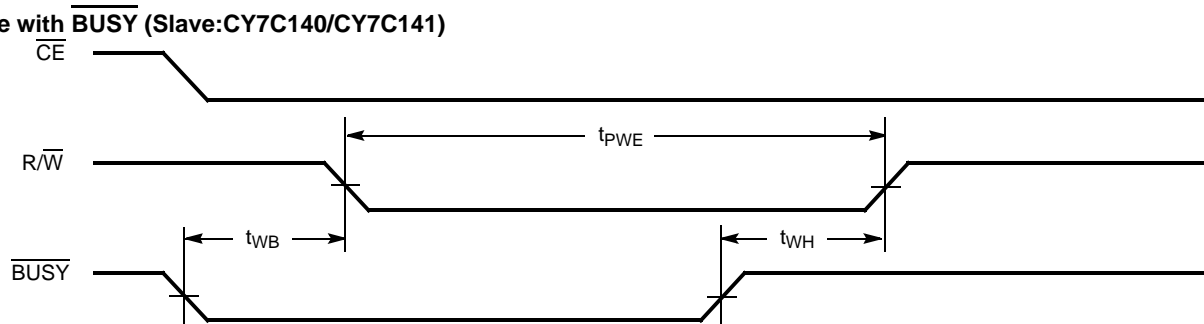

Switching Waveforms (continued)

Figure 13. Interrupt Timing Diagrams

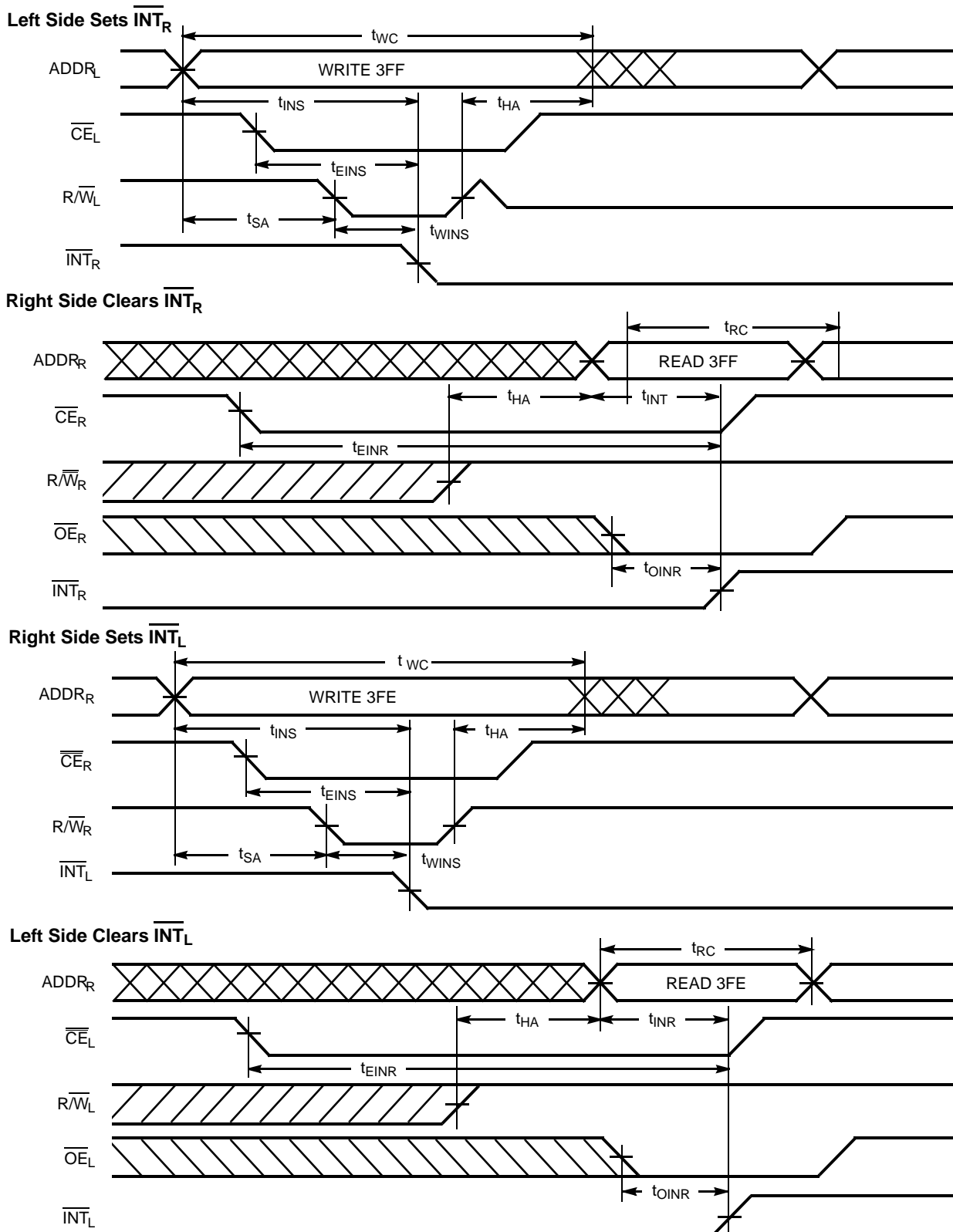

**Typical DC and AC Characteristics**

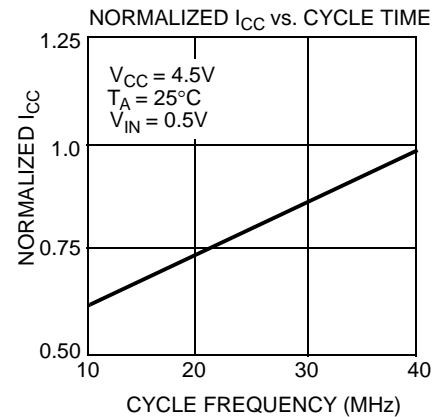
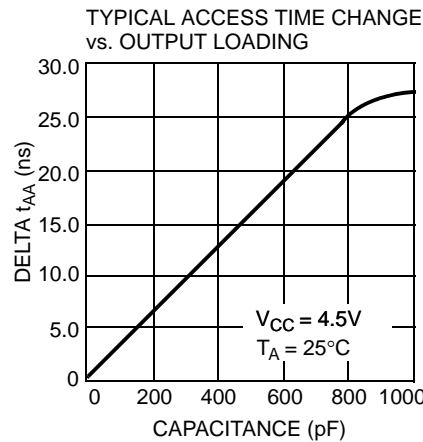
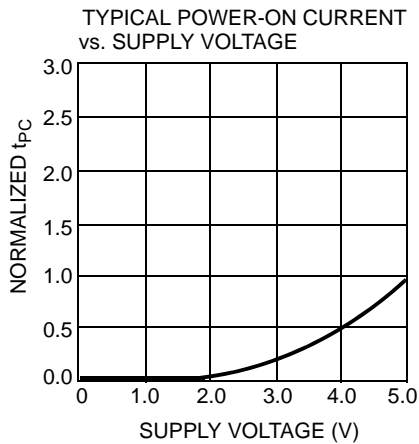
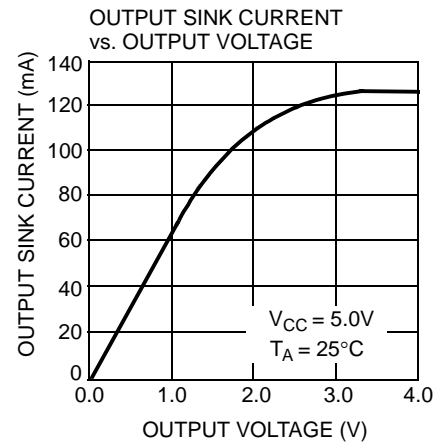
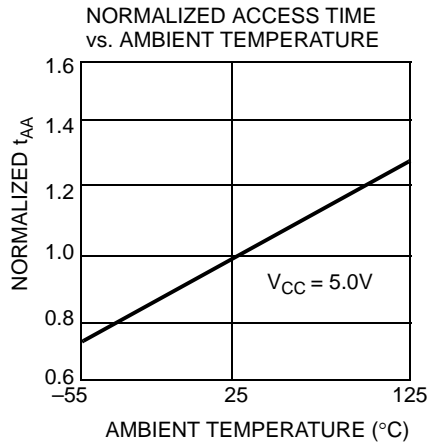
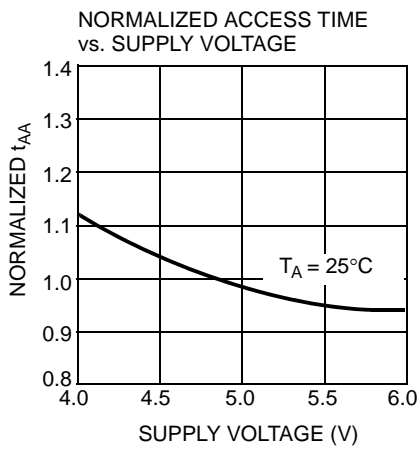
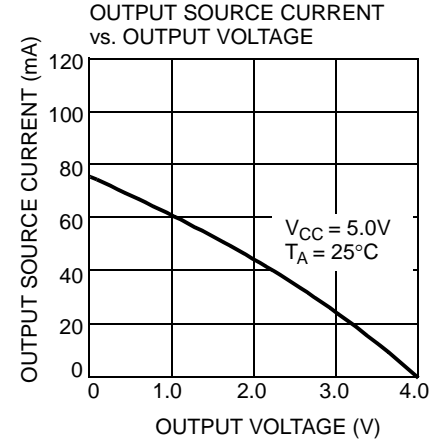
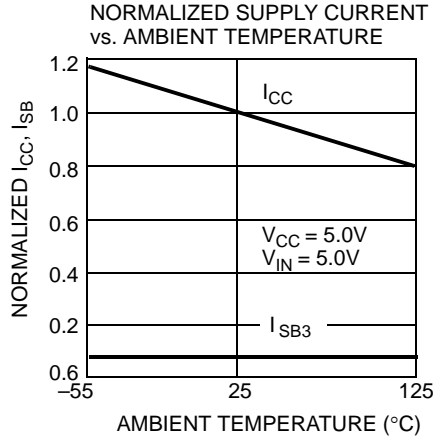
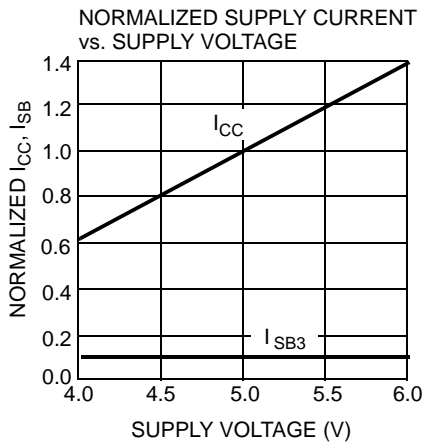

### Ordering Information

Speed (ns)	Ordering Code	Package Name	Package Type	Operating Range
55	CY7C130-55PC	P25	48-pin (600 Mil) Molded DIP	Commercial
15	CY7C131A-15JXI	J69	52-pin Pb-free Plastic Leaded Chip Carrier	Industrial
	CY7C131-15NXI	N52	52-pin Pb-free Plastic Quad Flatpack	
25	CY7C131-25JXC	J69	52-pin Pb-free Plastic Leaded Chip Carrier	Commercial
	CY7C131-25NXC	N52	52-pin Pb-free Plastic Quad Flatpack	
55	CY7C131-55JXC	J69	52-pin Pb-free Plastic Leaded Chip Carrier	Commercial
	CY7C131-55NXC	N52	52-pin Pb-free Plastic Quad Flatpack	
	CY7C131-55JXI	J69	52-pin Pb-free Plastic Leaded Chip Carrier	Industrial
	CY7C131-55NXI	N52	52-pin Pb-free Plastic Quad Flatpack	

### Ordering Code Definitions

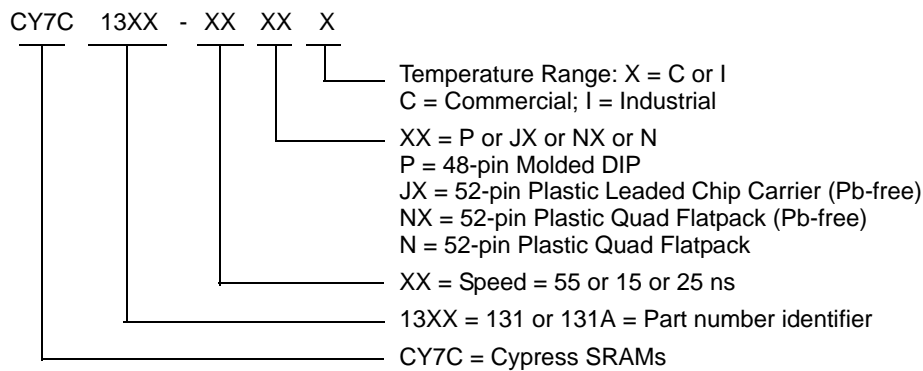

**Package Diagrams**

**Figure 14. 48-pin (600 Mil) Sidebrazed DIP D26**

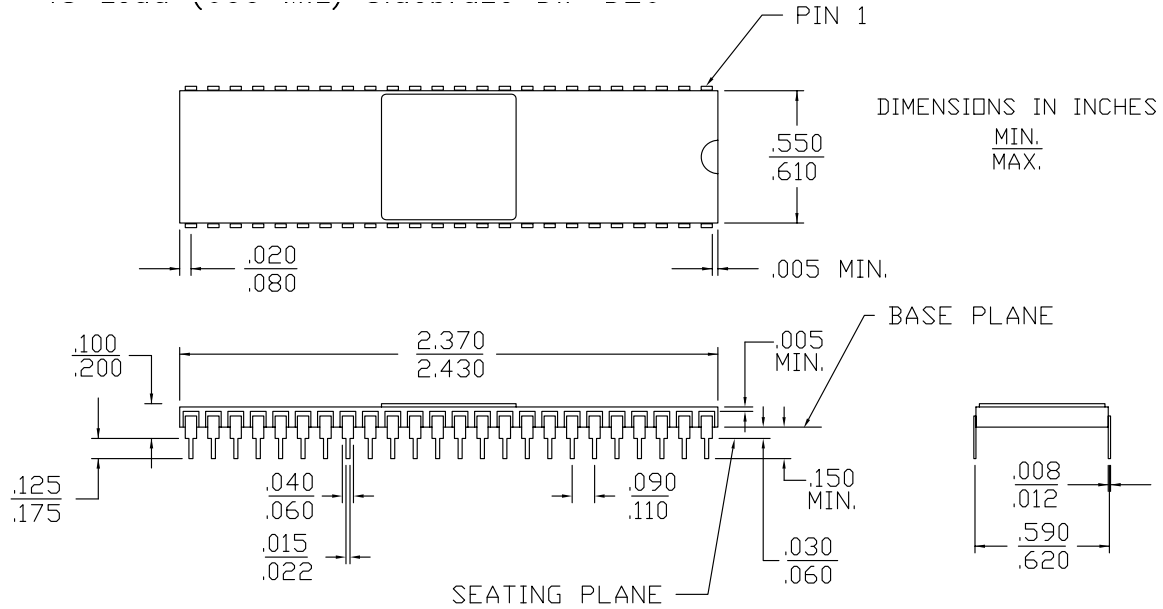

51-80044 \*B

**Figure 15. 52-pin Pb-free Plastic Leaded Chip Carrier J69**

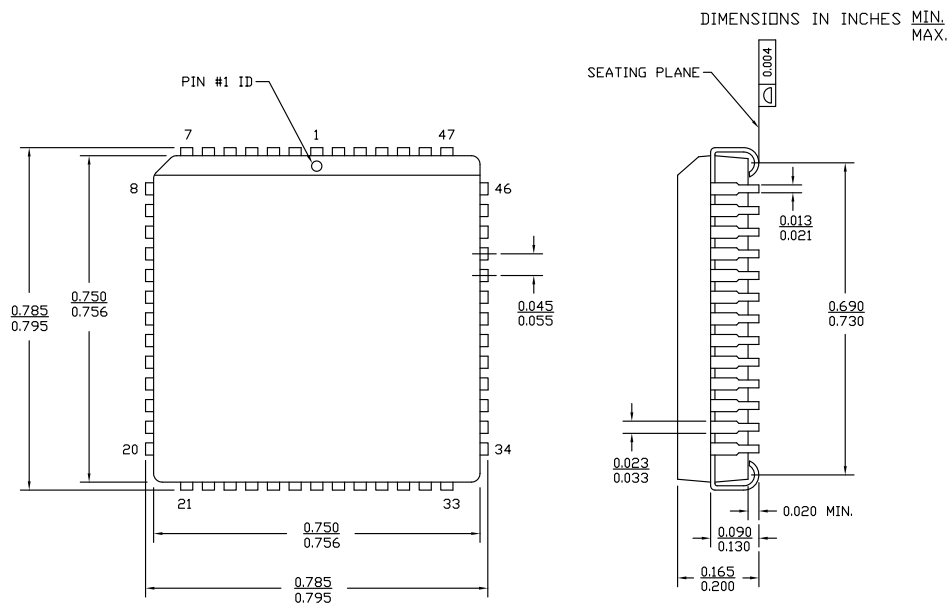

51-85004 \*C

**Package Diagrams** (continued)

**Figure 16. 48-pin (600 Mil) Molded DIP P25**

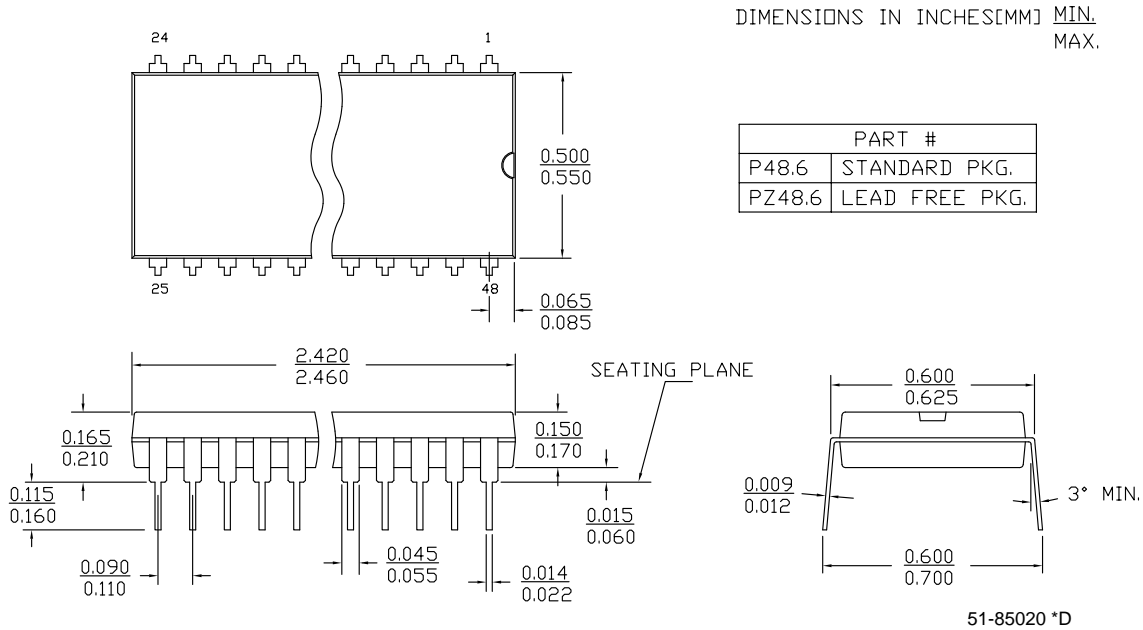

**Figure 17. 52-pin Pb-free Plastic Quad Flatpack N52**

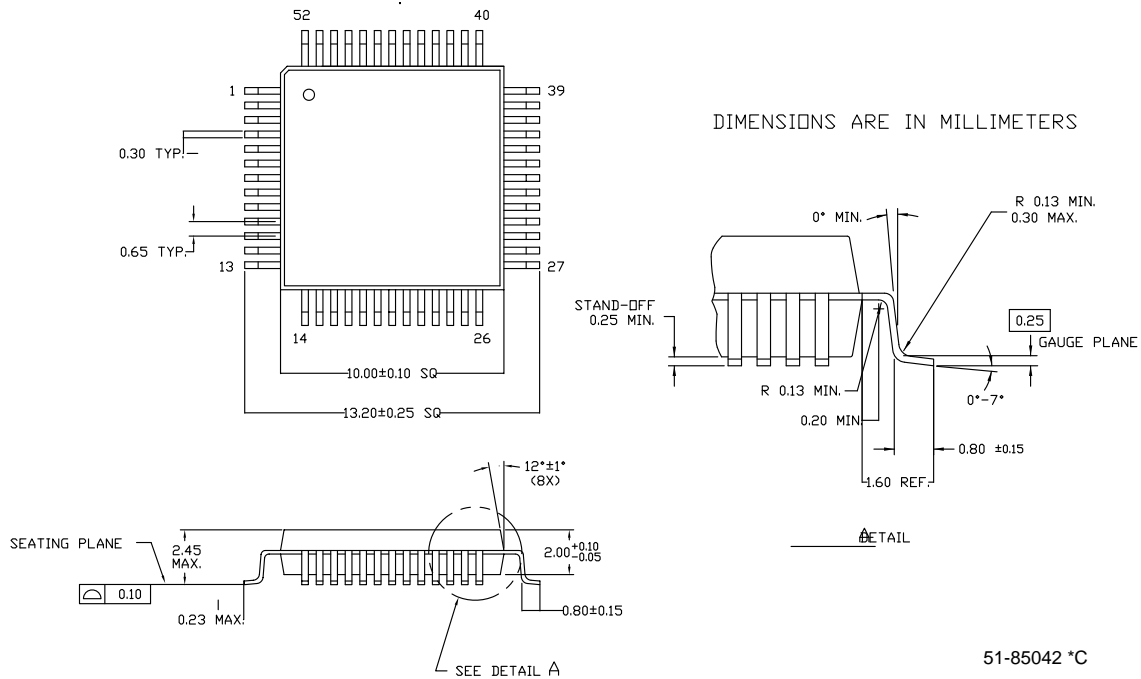

## Acronyms

Acronym	Description
CE	chip enable
CMOS	complementary metal oxide semiconductor
DIP	dual in-line package
I/O	input/output
OE	output enable
PLCC	plastic leaded chip carrier
PQFP	plastic quad flat pack
SRAM	static random access memory
TQFP	thin quad flat pack
TTL	Transistor–transistor logic

## Document Conventions

### Units of Measure

Symbol	Unit of Measure
°C	degree Celcius
MHz	megahertz
μA	microamperes
mA	milliamperes
ms	milliseconds
mV	millivolts
ns	nanoseconds
pF	picofarad
V	volts
W	watts

## Document History Page

Document Title: CY7C130/CY7C130A/CY7C131/CY7C131A 1K x 8 Dual-Port Static RAM				
Document Number: 38-06002				
Rev.	ECN No.	Orig. of Change	Submission Date	Description of Change
**	110169	SZV	09/29/01	Change from Spec number: 38-00027 to 38-06002
*A	122255	RBI	12/26/02	Power up requirements added to Maximum Ratings Information
*B	236751	YDT	See ECN	Removed cross information from features section
*C	325936	RUJ	See ECN	Added pin definitions table, 52-pin PQFP package diagram and Pb-free information
*D	393153	YIM	See ECN	Added CY7C131-15JI to ordering information Added Pb-Free parts to ordering information: CY7C131-15JXI
*E	2623540	VKN/PYRS	12/17/08	Added CY7C130A and CY7C131A parts Removed military information Updated ordering information table
*F	2897217	RAME	03/22/2010	Updated Ordering Information Updated Package Diagrams
*G	3054633	ADMU	10/11/2010	Updated <a href="#">Ordering Information</a> and added <a href="#">Ordering Code Definitions</a> . Updated <a href="#">Package Diagrams</a> . Added <a href="#">Acronyms</a> and <a href="#">Units of Measure</a> . Minor edits and updated in new template.
*H	3402163	ADMU	10/12/2011	Removed pruned part CY7C131-25NC from <a href="#">Ordering Information</a> Updated <a href="#">Package Diagrams</a> .

## Sales, Solutions, and Legal Information

### Worldwide Sales and Design Support

Cypress maintains a worldwide network of offices, solution centers, manufacturer's representatives, and distributors. To find the office closest to you, visit us at [Cypress Locations](#).

### Products

<a href="#">Automotive</a>	<a href="http://cypress.com/go/automotive">cypress.com/go/automotive</a>
<a href="#">Clocks &amp; Buffers</a>	<a href="http://cypress.com/go/clocks">cypress.com/go/clocks</a>
<a href="#">Interface</a>	<a href="http://cypress.com/go/interface">cypress.com/go/interface</a>
<a href="#">Lighting &amp; Power Control</a>	<a href="http://cypress.com/go/powerpsoc">cypress.com/go/powerpsoc</a> <a href="http://cypress.com/go/plc">cypress.com/go/plc</a>
<a href="#">Memory</a>	<a href="http://cypress.com/go/memory">cypress.com/go/memory</a>
<a href="#">Optical &amp; Image Sensing</a>	<a href="http://cypress.com/go/image">cypress.com/go/image</a>
<a href="#">PSoC</a>	<a href="http://cypress.com/go/psoc">cypress.com/go/psoc</a>
<a href="#">Touch Sensing</a>	<a href="http://cypress.com/go/touch">cypress.com/go/touch</a>
<a href="#">USB Controllers</a>	<a href="http://cypress.com/go/USB">cypress.com/go/USB</a>
<a href="#">Wireless/RF</a>	<a href="http://cypress.com/go/wireless">cypress.com/go/wireless</a>

### PSoC Solutions

[psoc.cypress.com/solutions](http://psoc.cypress.com/solutions)  
PSoC 1 | PSoC 3 | PSoC 5

---

© Cypress Semiconductor Corporation, 2001-2011. The information contained herein is subject to change without notice. Cypress Semiconductor Corporation assumes no responsibility for the use of any circuitry other than circuitry embodied in a Cypress product. Nor does it convey or imply any license under patent or other rights. Cypress products are not warranted nor intended to be used for medical, life support, life saving, critical control or safety applications, unless pursuant to an express written agreement with Cypress. Furthermore, Cypress does not authorize its products for use as critical components in life-support systems where a malfunction or failure may reasonably be expected to result in significant injury to the user. The inclusion of Cypress products in life-support systems application implies that the manufacturer assumes all risk of such use and in doing so indemnifies Cypress against all charges.

Any Source Code (software and/or firmware) is owned by Cypress Semiconductor Corporation (Cypress) and is protected by and subject to worldwide patent protection (United States and foreign), United States copyright laws and international treaty provisions. Cypress hereby grants to licensee a personal, non-exclusive, non-transferable license to copy, use, modify, create derivative works of, and compile the Cypress Source Code and derivative works for the sole purpose of creating custom software and or firmware in support of licensee product to be used only in conjunction with a Cypress integrated circuit as specified in the applicable agreement. Any reproduction, modification, translation, compilation, or representation of this Source Code except as specified above is prohibited without the express written permission of Cypress.

Disclaimer: CYPRESS MAKES NO WARRANTY OF ANY KIND, EXPRESS OR IMPLIED, WITH REGARD TO THIS MATERIAL, INCLUDING, BUT NOT LIMITED TO, THE IMPLIED WARRANTIES OF MERCHANTABILITY AND FITNESS FOR A PARTICULAR PURPOSE. Cypress reserves the right to make changes without further notice to the materials described herein. Cypress does not assume any liability arising out of the application or use of any product or circuit described herein. Cypress does not authorize its products for use as critical components in life-support systems where a malfunction or failure may reasonably be expected to result in significant injury to the user. The inclusion of Cypress' product in a life-support systems application implies that the manufacturer assumes all risk of such use and in doing so indemnifies Cypress against all charges.

Use may be limited by and subject to the applicable Cypress software license agreement.

## Looking for pricing, stock, or lifecycle information?

Click below to explore more details on WIN SOURCE:

 [View CY7C131-25NC on WIN SOURCE](#)

 [Infineon Technologies](#) Information

## Optimize Your Supply Chain with WIN SOURCE Solutions

-  Global Sourcing Solution
-  Obsolete Management
-  Cost Control Management
-  Shortage Management
-  Alternative Solution
-  Excess Inventory Management