



**THE DATASHEET OF
CY7C131-25JC**





CY7C130/CY7C131 CY7C140/CY7C141

1K x 8 Dual-Port Static Ram

Features

- True Dual-Ported memory cells which allow simultaneous reads of the same memory location
- 1K x 8 organization
- 0.65-micron CMOS for optimum speed/power
- High-speed access: 15 ns
- Low operating power: I_{CC} = 90 mA (max.)
- Fully asynchronous operation
- Automatic power-down
- Master CY7C130/CY7C131 easily expands data bus width to 16 or more bits using slave CY7C140/CY7C141
- **BUSY** output flag on CY7C130/CY7C131; **BUSY** input on CY7C140/CY7C141
- **INT** flag for port-to-port communication
- Available in 48-pin DIP (CY7C130/140), 52-pin PLCC and 52-pin TQFP
- Pin-compatible and functionally equivalent to IDT7130/IDT7140

Functional Description

The CY7C130/CY7C131/CY7C140 and CY7C141 are high-speed CMOS 1K by 8 dual-port static RAMs. Two ports are provided permitting independent access to any location in memory. The CY7C130/ CY7C131 can be utilized as either a standalone 8-bit dual-port static RAM or as a master dual-port RAM in conjunction with the CY7C140/CY7C141 slave dual-port device in systems requiring 16-bit or greater word widths. It is the solution to applications requiring shared or buffered data, such as cache memory for DSP, bit-slice, or multiprocessor designs.

Each port has independent control pins; chip enable (\overline{CE}), write enable (R/\overline{W}), and output enable (\overline{OE}). Two flags are provided on each port, \overline{BUSY} and \overline{INT} . \overline{BUSY} signals that the port is trying to access the same location currently being accessed by the other port. \overline{INT} is an interrupt flag indicating that data has been placed in a unique location (3FF for the left port and 3FE for the right port). An automatic power-down feature is controlled independently on each port by the chip enable (\overline{CE}) pins.

The CY7C130 and CY7C140 are available in 48-pin DIP. The CY7C131 and CY7C141 are available in 52-pin PLCC and PQFP.

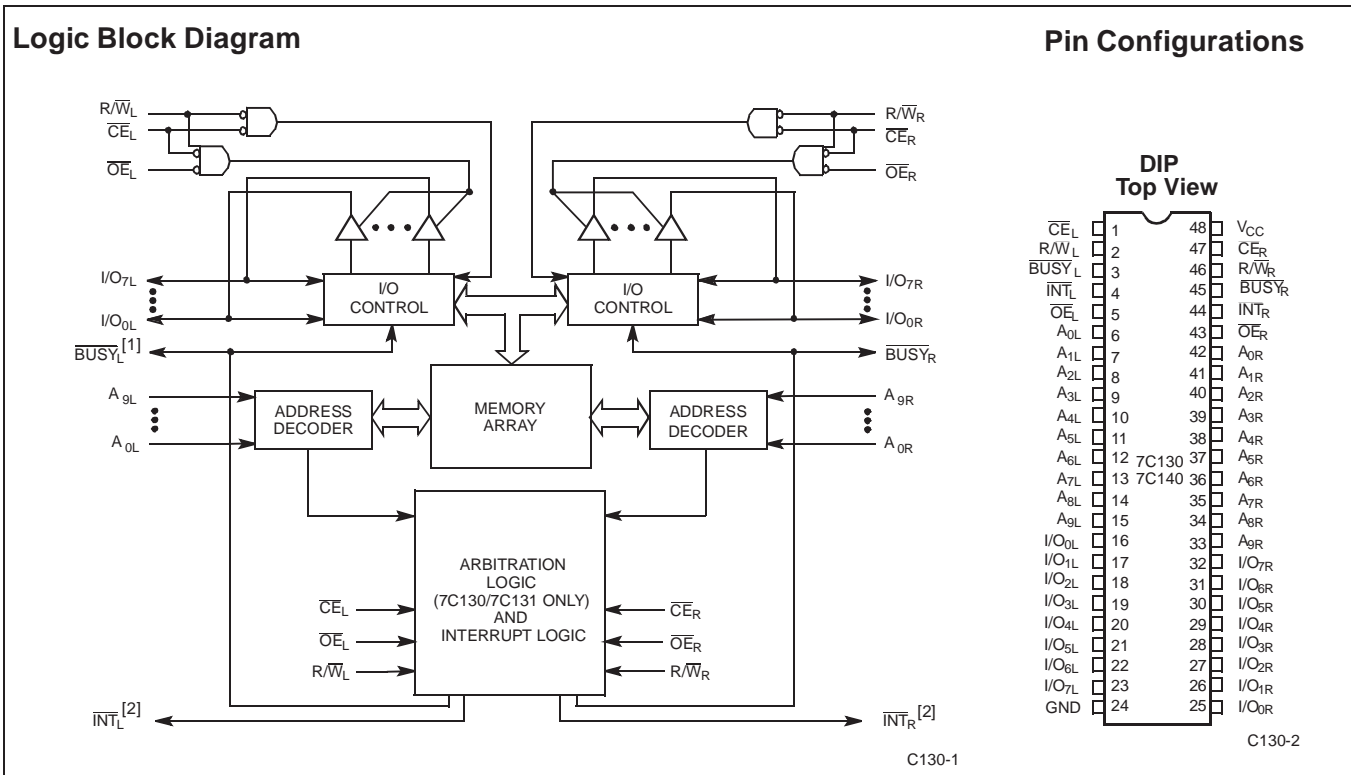

- Notes:**
1. CY7C130/CY7C131 (Master): \overline{BUSY} is open drain output and requires pull-up resistor
CY7C140/CY7C141 (Slave): \overline{BUSY} is input.
 2. Open drain outputs: pull-up resistor required

Pin Configuration (continued)

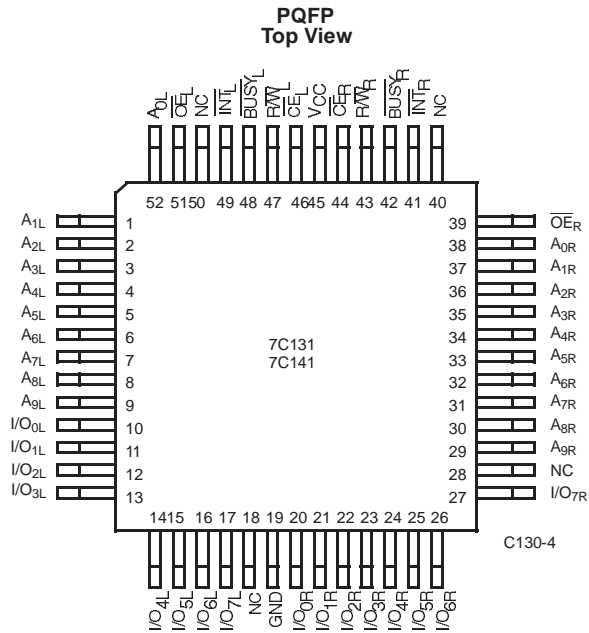
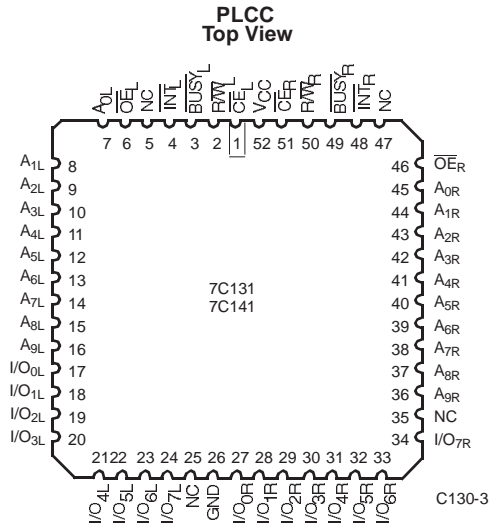

Selection Guide

		7C131-15 ^[3,4] 7C141-15	7C131-25 ^[3] 7C141-25	7C130-30 7C131-30 7C140-30 7C141-30	7C130-35 7C131-35 7C140-35 7C141-35	7C130-45 7C131-45 7C140-45 7C141-45	7C130-55 7C131-55 7C140-55 7C141-55
Maximum Access Time (ns)		15	25	30	35	45	55
Maximum Operating Current (mA)	Com'l/Ind	190	170	170	120	90	90
	Military				170	120	120
Maximum Standby Current (mA)	Com'l/Ind	75	65	65	45	35	35
	Military				65	45	45

Maximum Ratings

(Above which the useful life may be impaired. For user guidelines, not tested.)

Storage Temperature -65°C to +150°C

Ambient Temperature with Power Applied..... -55°C to +125°C

Supply Voltage to Ground Potential (Pin 48 to Pin 24) -0.5V to +7.0V

DC Voltage Applied to Outputs in High Z State -0.5V to +7.0V

DC Input Voltage..... -3.5V to +7.0V

Output Current into Outputs (LOW)20 mA

Notes:

3. 15 and 25-ns version available only in PLCC/PQFP packages.
4. Shaded area contains preliminary information.
5. T_A is the "instant on" case temperature

Static Discharge Voltage >2001V (per MIL-STD-883, Method 3015)

Latch-Up Current..... >200 mA

Operating Range

Range	Ambient Temperature	V _{CC}
Commercial	0°C to +70°C	5V ± 10%
Industrial	-40°C to +85°C	5V ± 10%
Military ^[5]	-55°C to +125°C	5V ± 10%



Electrical Characteristics Over the Operating Range^[6]

Parameter	Description	Test Conditions	7C131-15 ^[3,4] 7C141-15		7C130-30 ^[3] 7C131-25,30 7C140-30 7C141-25,30		7C130-35 7C131-35 7C140-35 7C141-35		7C130-45,55 7C131-45,55 7C140-45,55 7C141-45,55		Unit
			Min.	Max.	Min.	Max.	Min.	Max.	Min.	Max.	
V _{OH}	Output HIGH Voltage	V _{CC} = Min., I _{OH} = -4.0 mA	2.4		2.4		2.4		2.4		V
V _{OL}	Output LOW Voltage	I _{OL} = 4.0 mA		0.4		0.4		0.4		0.4	V
		I _{OL} = 16.0 mA ^[7]		0.5		0.5		0.5		0.5	
V _{IH}	Input HIGH Voltage		2.2		2.2		2.2		2.2		V
V _{IL}	Input LOW Voltage			0.8		0.8		0.8		0.8	V
I _{Ix}	Input Leakage Current	GND ≤ V _I ≤ V _{CC}	-5	+5	-5	+5	-5	+5	-5	+5	μA
I _{OZ}	Output Leakage Current	GND ≤ V _O ≤ V _{CC} , Output Disabled	-5	+5	-5	+5	-5	+5	-5	+5	μA
I _{OS}	Output Short Circuit Current ^[8, 9]	V _{CC} = Max., V _{OUT} = GND		-350		-350		-350		-350	mA
I _{CC}	V _{CC} Operating Supply Current	CE = V _{IL} , Outputs Open, f = f _{MAX} ^[10]	Com'l	190		170		120		90	mA
			Mil					170		120	
I _{SB1}	Standby Current Both Ports, TTL Inputs	CE _L and CE _R ≥ V _{IH} , f = f _{MAX} ^[10]	Com'l	75		65		45		35	mA
			Mil					65		45	
I _{SB2}	Standby Current One Port, TTL Inputs	CE _L or CE _R ≥ V _{IH} , Active Port Outputs Open, f = f _{MAX} ^[10]	Com'l	135		115		90		75	mA
			Mil					115		90	
I _{SB3}	Standby Current Both Ports, CMOS Inputs	Both Ports CE _L and CE _R ≥ V _{CC} - 0.2V, V _{IN} ≥ V _{CC} - 0.2V or V _{IN} ≤ 0.2V, f = 0	Com'l	15		15		15		15	mA
			Mil					15		15	
I _{SB4}	Standby Current One Port, CMOS Inputs	One Port CE _L or CE _R ≥ V _{CC} - 0.2V, V _{IN} ≥ V _{CC} - 0.2V or V _{IN} ≤ 0.2V, Active Port Outputs Open, f = f _{MAX} ^[10]	Com'l	125		105		85		70	mA
			Mil					105		85	

Notes:

6. See the last page of this specification for Group A subgroup testing information.
7. BUSY and INT pins only.
8. Duration of the short circuit should not exceed 30 seconds.
9. This parameter is guaranteed but not tested.
10. At f = f_{MAX}, address and data inputs are cycling at the maximum frequency of read cycle of 1/t_{RC} and using AC Test Waveforms input levels of GND to 3V.

Capacitance^[9]

Parameter	Description	Test Conditions	Max.	Unit
C _{IN}	Input Capacitance	T _A = 25°C, f = 1 MHz, V _{CC} = 5.0V	15	pF
C _{OUT}	Output Capacitance		10	pF

AC Test Loads and Waveforms

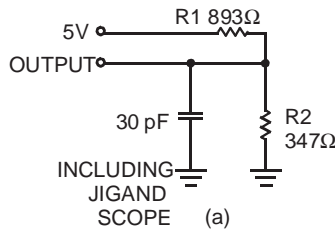

(a)

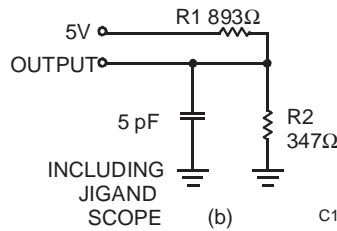

(b)

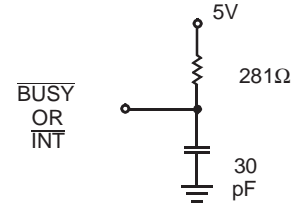

BUSY Output Load
(CY7C130/CY7C131 ONLY)

C130-6

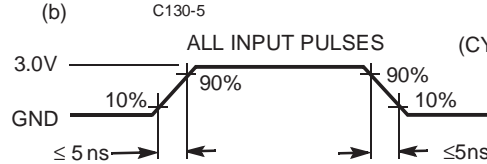
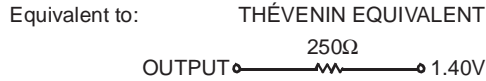

Switching Characteristics Over the Operating Range^[6,11]

Parameter	Description	7C131-15 ^[3,4] 7C141-15		7C130-25 ^[3] 7C131-25 7C140-25 7C141-25		7C130-30 7C131-30 7C140-30 7C141-30		Unit
		Min.	Max.	Min.	Max.	Min.	Max.	
READ CYCLE ^[15]								
t _{RC}	Read Cycle Time	15		25		30		ns
t _{AA}	Address to Data Valid ^[12]		15		25		30	ns
t _{OHA}	Data Hold from Address Change	0		0		0		ns
t _{ACE}	\overline{CE} LOW to Data Valid ^[12]		15		25		30	ns
t _{DOE}	\overline{OE} LOW to Data Valid ^[12]		10		15		20	ns
t _{LZOE}	\overline{OE} LOW to Low Z ^[9,13,14]	3		3		3		ns
t _{HZOE}	\overline{OE} HIGH to High Z ^[9,13,14]		10		15		15	ns
t _{LZCE}	\overline{CE} LOW to Low Z ^[9,13,14]	3		5		5		ns
t _{HZCE}	\overline{CE} HIGH to High Z ^[9,13,14]		10		15		15	ns
t _{PU}	\overline{CE} LOW to Power-Up ^[9]	0		0		0		ns
t _{PD}	\overline{CE} HIGH to Power-Down ^[9]		15		25		25	ns
WRITE CYCLE ^[15]								
t _{WC}	Write Cycle Time	15		25		30		ns
t _{SCE}	\overline{CE} LOW to Write End	12		20		25		ns
t _{AW}	Address Set-Up to Write End	12		20		25		ns
t _{HA}	Address Hold from Write End	2		2		2		ns
t _{SA}	Address Set-Up to Write Start	0		0		0		ns
t _{PWE}	R \overline{W} Pulse Width	12		15		25		ns
t _{SD}	Data Set-Up to Write End	10		15		15		ns
t _{HD}	Data Hold from Write End	0		0		0		ns
t _{HZWE}	R \overline{W} LOW to High Z ^[14]		10		15		15	ns
t _{LZWE}	R \overline{W} HIGH to Low Z ^[14]	0		0		0		ns

Notes:

- Test conditions assume signal transition times of 5 ns or less, timing reference levels of 1.5V, input pulse levels of 0 to 3.0V and output loading of the specified I_{OL}/I_{OH} and 30-pF load capacitance.
- AC Test Conditions use V_{OH} = 1.6V and V_{OL} = 1.4V.
- At any given temperature and voltage condition for any given device, t_{HZCE} is less than t_{LZCE} and t_{HZOE} is less than t_{LZOE}.
- t_{LZCE}, t_{LZWE}, t_{HZOE}, t_{LZOE}, t_{HZCE} and t_{HZWE} are tested with C_L = 5pF as in part (b) of AC Test Loads. Transition is measured ±500 mV from steady state voltage.
- The internal write time of the memory is defined by the overlap of CS LOW and R \overline{W} LOW. Both signals must be low to initiate a write and either signal can terminate a write by going high. The data input set-up and hold timing should be referenced to the rising edge of the signal that terminates the write

Switching Characteristics Over the Operating Range^[6,11] (continued)

Parameter	Description	7C131-15 ^[3,4] 7C141-15		7C130-25 ^[3] 7C131-25 7C140-25 7C141-25		7C130-30 7C131-30 7C140-30 7C141-30		Unit
		Min.	Max.	Min.	Max.	Min.	Max.	
BUSY/INTERRUPT TIMING								
t _{BLA}	BUSY LOW from Address Match		15		20		20	ns
t _{BHA}	BUSY HIGH from Address Mismatch ^[16]		15		20		20	ns
t _{BLC}	BUSY LOW from CE LOW		15		20		20	ns
t _{BHC}	BUSY HIGH from CE HIGH ^[16]		15		20		20	ns
t _{PS}	Port Set Up for Priority	5		5		5		ns
t _{WB} ^[17]	R/W LOW after BUSY LOW	0		0		0		ns
t _{WH}	R/W HIGH after BUSY HIGH	13		20		30		ns
t _{BDD}	BUSY HIGH to Valid Data		15		25		30	ns
t _{DDD}	Write Data Valid to Read Data Valid		Note 18		Note 18		Note 18	ns
t _{WDD}	Write Pulse to Data Delay		Note 18		Note 18		Note 18	ns
INTERRUPT TIMING								
t _{WINS}	R/W to INTERRUPT Set Time		15		25		25	ns
t _{EINS}	CE to INTERRUPT Set Time		15		25		25	ns
t _{INS}	Address to INTERRUPT Set Time		15		25		25	ns
t _{OINR}	OE to INTERRUPT Reset Time ^[16]		15		25		25	ns
t _{EINR}	CE to INTERRUPT Reset Time ^[16]		15		25		25	ns
t _{INR}	Address to INTERRUPT Reset Time ^[16]		15		25		25	ns

Notes:

16. These parameters are measured from the input signal changing, until the output pin goes to a high-impedance state.
17. CY7C140/CY7C141 only.
18. A write operation on Port A, where Port A has priority, leaves the data on Port B's outputs undisturbed until one access time after one of the following:
 BUSY on Port B goes HIGH.
 Port B's address is toggled.
 CE for Port B is toggled.
 R/W for Port B is toggled during valid read.

Switching Characteristics Over the Operating Range^[6,11]

Parameter	Description	7C130-35 7C131-35 7C140-35 7C141-35		7C130-45 7C131-45 7C140-45 7C141-45		7C130-55 7C131-55 7C140-55 7C141-55		Unit
		Min.	Max.	Min.	Max.	Min.	Max.	
READ CYCLE								
t _{RC}	Read Cycle Time	35		45		55		ns
t _{AA}	Address to Data Valid ^[12]		35		45		55	ns
t _{OHA}	Data Hold from Address Change	0		0		0		ns
t _{ACE}	CE LOW to Data Valid ^[12]		35		45		55	ns
t _{DOE}	OE LOW to Data Valid ^[12]		20		25		25	ns
t _{LZOE}	OE LOW to Low Z ^[9,13, 14]	3		3		3		ns
t _{HZOE}	OE HIGH to High Z ^[9,13, 14]		20		20		25	ns
t _{LZCE}	CE LOW to Low Z ^[9,13, 14]	5		5		5		ns
t _{HZCE}	CE HIGH to High Z ^[9,13, 14]		20		20		25	ns
t _{PU}	CE LOW to Power-Up ^[9]	0		0		0		ns
t _{PD}	CE HIGH to Power-Down ^[9]		35		35		35	ns



Switching Characteristics Over the Operating Range^[6,11] (continued)

Parameter	Description	7C130-35 7C131-35 7C140-35 7C141-35		7C130-45 7C131-45 7C140-45 7C141-45		7C130-55 7C131-55 7C140-55 7C141-55		Unit
		Min.	Max.	Min.	Max.	Min.	Max.	
WRITE CYCLE^[15]								
t _{WC}	Write Cycle Time	35		45		55		ns
t _{SCE}	\overline{CE} LOW to Write End	30		35		40		ns
t _{AW}	Address Set-Up to Write End	30		35		40		ns
t _{HA}	Address Hold from Write End	2		2		2		ns
t _{SA}	Address Set-Up to Write Start	0		0		0		ns
t _{PWE}	R/ \overline{W} Pulse Width	25		30		30		ns
t _{SD}	Data Set-Up to Write End	15		20		20		ns
t _{HD}	Data Hold from Write End	0		0		0		ns
t _{HZWE}	R/ \overline{W} LOW to High Z ^[14]		20		20		25	ns
t _{LZWE}	R/ \overline{W} HIGH to Low Z ^[14]	0		0		0		ns
BUSY/INTERRUPT TIMING								
t _{BLA}	\overline{BUSY} LOW from Address Match		20		25		30	ns
t _{BHA}	\overline{BUSY} HIGH from Address Mismatch ^[16]		20		25		30	ns
t _{BLC}	\overline{BUSY} LOW from \overline{CE} LOW		20		25		30	ns
t _{BHC}	\overline{BUSY} HIGH from \overline{CE} HIGH ^[16]		20		25		30	ns
t _{PS}	Port Set Up for Priority	5		5		5		ns
t _{WB^[17]}	R/ \overline{W} LOW after \overline{BUSY} LOW	0		0		0		ns
t _{WH}	R/ \overline{W} HIGH after \overline{BUSY} HIGH	30		35		35		ns
t _{BDD}	\overline{BUSY} HIGH to Valid Data		35		45		45	ns
t _{DDD}	Write Data Valid to Read Data Valid		Note 18		Note 18		Note 18	ns
t _{WDD}	Write Pulse to Data Delay		Note 18		Note 18		Note 18	ns
INTERRUPT TIMING								
t _{WINS}	R/ \overline{W} to $\overline{INTERRUPT}$ Set Time		25		35		45	ns
t _{EINS}	\overline{CE} to $\overline{INTERRUPT}$ Set Time		25		35		45	ns
t _{INS}	Address to $\overline{INTERRUPT}$ Set Time		25		35		45	ns
t _{OINR}	\overline{OE} to $\overline{INTERRUPT}$ Reset Time ^[16]		25		35		45	ns
t _{EINR}	\overline{CE} to $\overline{INTERRUPT}$ Reset Time ^[16]		25		35		45	ns
t _{INR}	Address to $\overline{INTERRUPT}$ Reset Time ^[16]		25		35		45	ns

Switching Waveforms

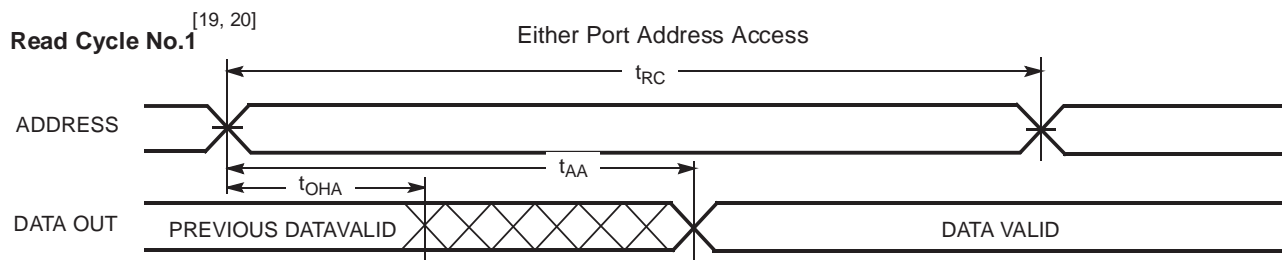

C130-7

Notes:

- 19. R/ \overline{W} is HIGH for read cycle.
- 20. Device is continuously selected, $\overline{CE} = V_{IL}$ and $\overline{OE} = V_{IL}$.

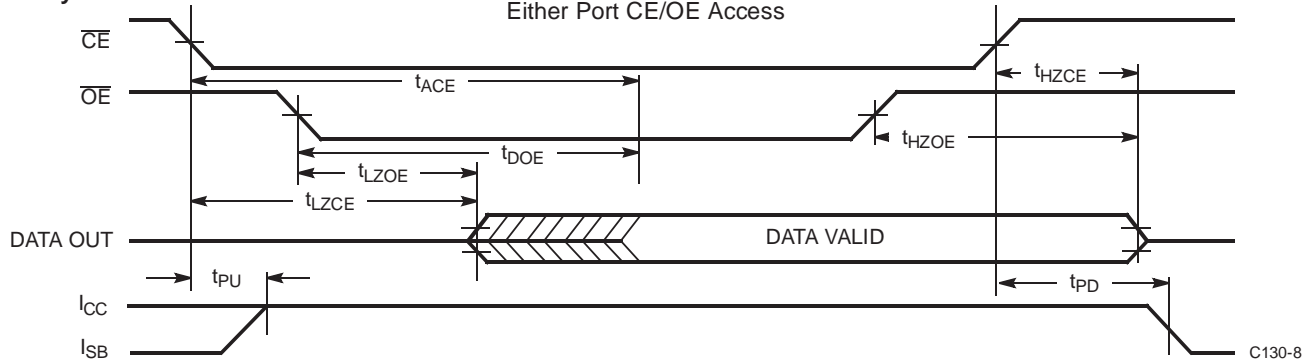
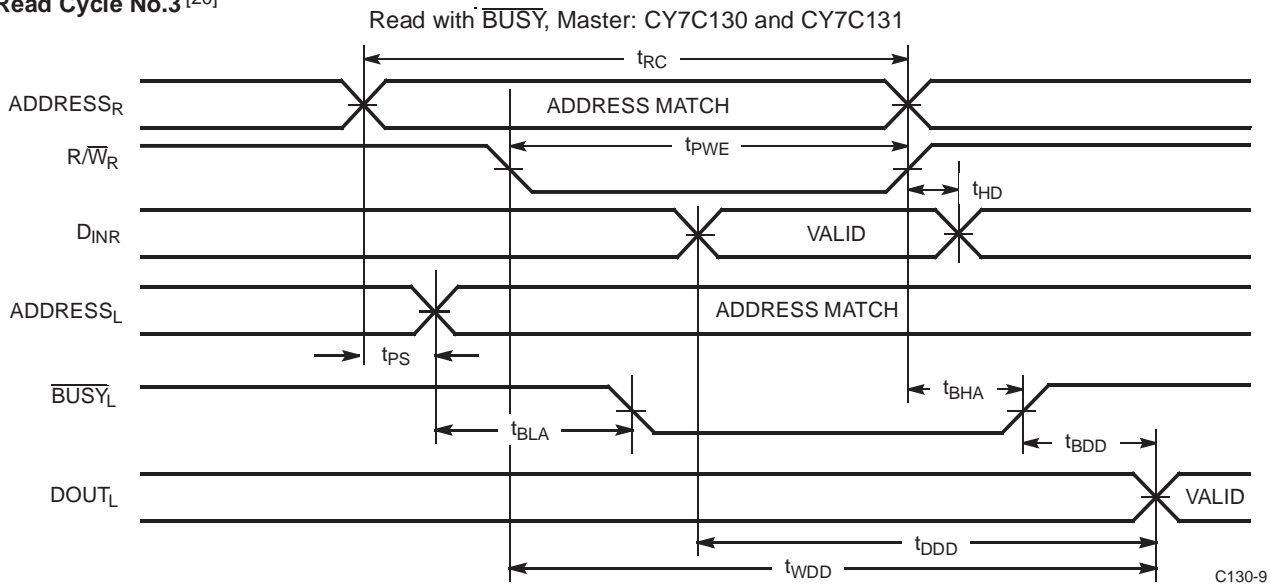
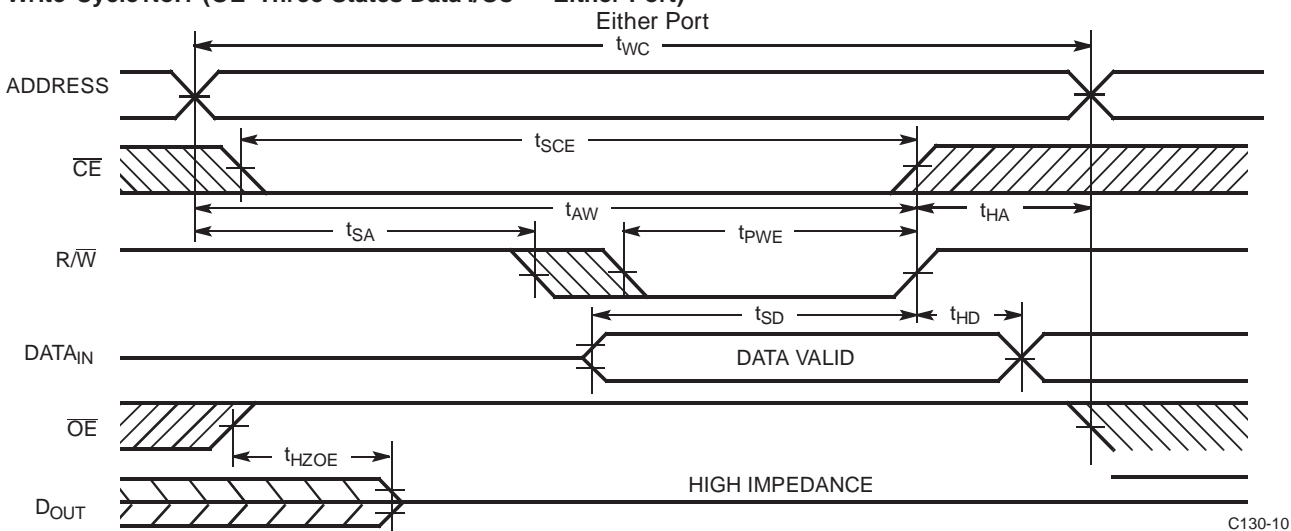
Switching Waveforms (continued)
Read Cycle No. 2 ^[19, 21]

Read Cycle No.3 ^[20]

Write Cycle No.1 (OE Three-States Data I/Os - Either Port) ^[15, 22]

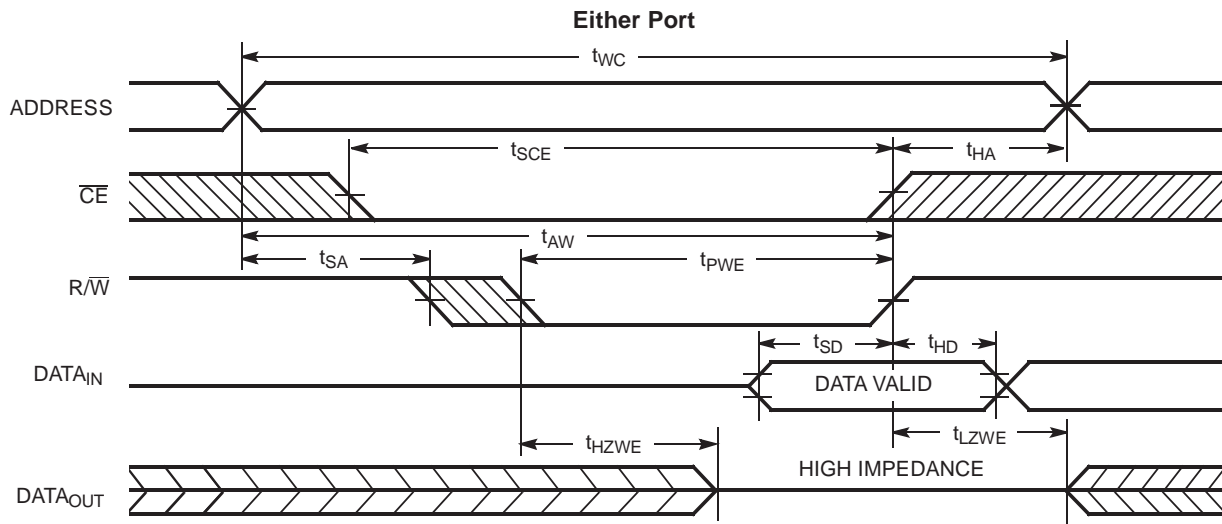
Notes:

21. Address valid prior to or coincident with \overline{CE} transition LOW.

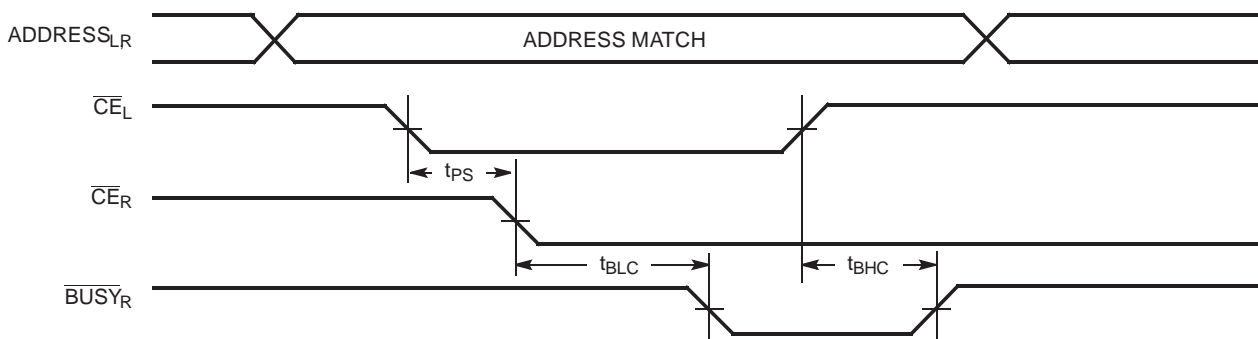
22. If \overline{OE} is LOW during a R/\overline{W} controlled write cycle, the write pulse width must be the larger of t_{PWE} or $t_{HZOE} + t_{SD}$ to allow the data I/O pins to enter high impedance and for data to be placed on the bus for the required t_{SD} .

Switching Waveforms (continued)
Write Cycle No. 2 (R/W Three-States Data I/Os - Either Port) ^[16, 23]

C130-11

Busy Timing Diagram No. 1 (\overline{CE} Arbitration)
 \overline{CE}_L Valid First:

C130-12

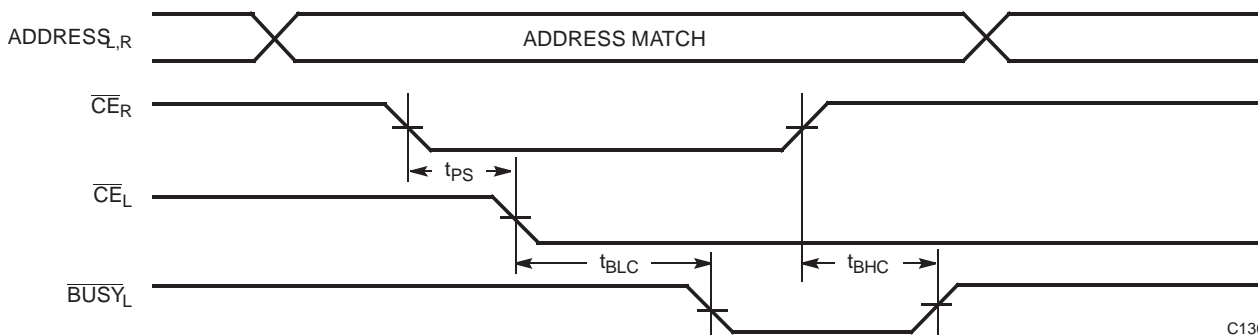
 \overline{CE}_R Valid First:

C130-13

Note:

 23. If the \overline{CE} LOW transition occurs simultaneously with or after the R/\overline{W} LOW transition, the outputs remain in the high-impedance state

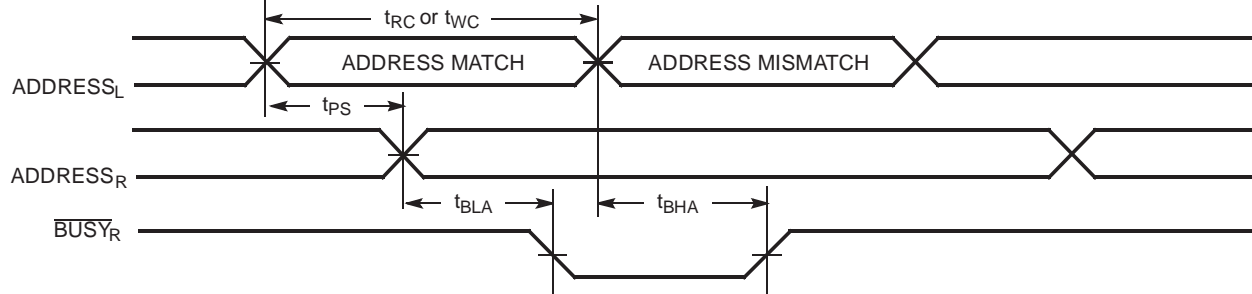
Switching Waveforms (continued)
Busy Timing Diagram No. 2 (Address Arbitration)
Left Address Valid First:

C130-14

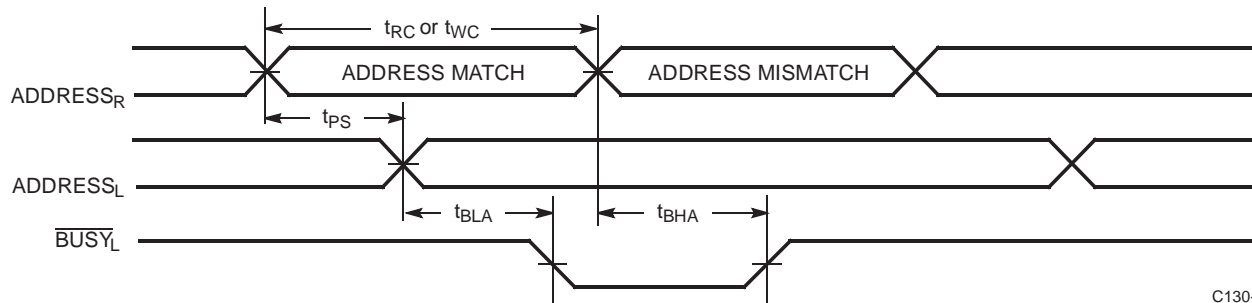
Right Address Valid First:

C130-15

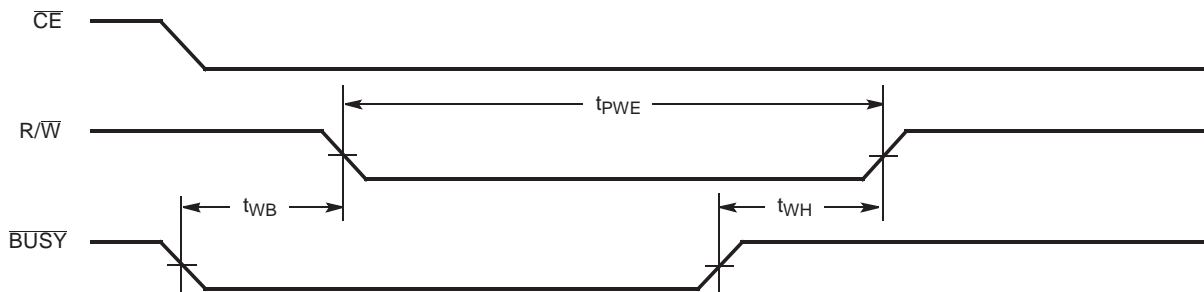
Busy Timing Diagram No. 3
Write with $\overline{\text{BUSY}}$ (Slave: CY7C140/CY7C141)

C130-16

Switching Waveforms (continued)

Interrupt Timing Diagrams

Left Side Sets \overline{INT}_R

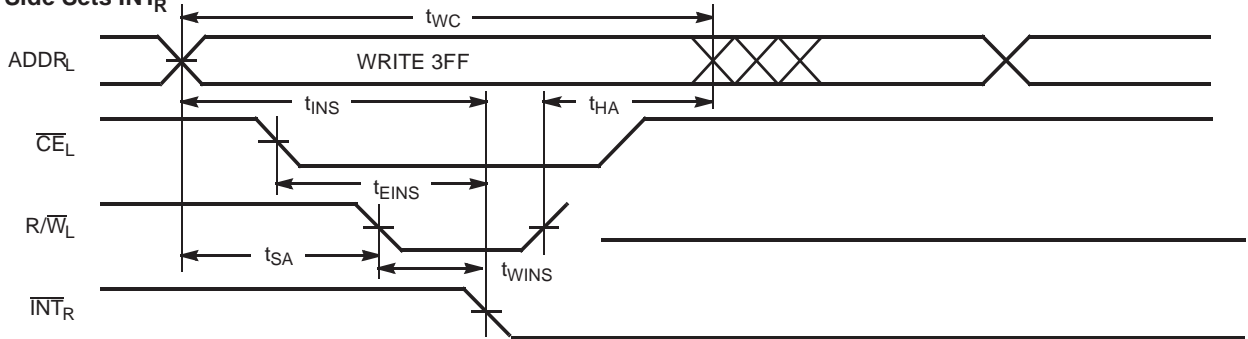

Right Side Clears \overline{INT}_R

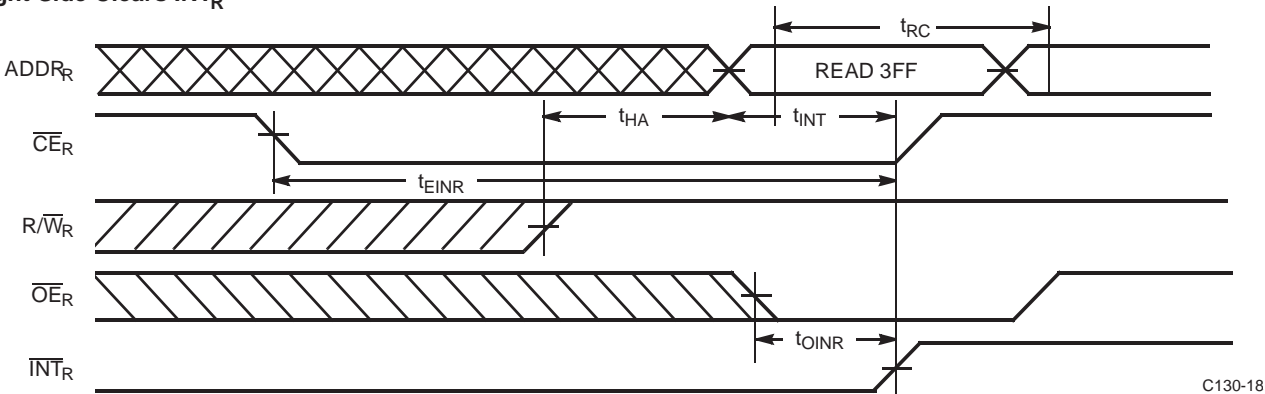

Right Side Sets \overline{INT}_L

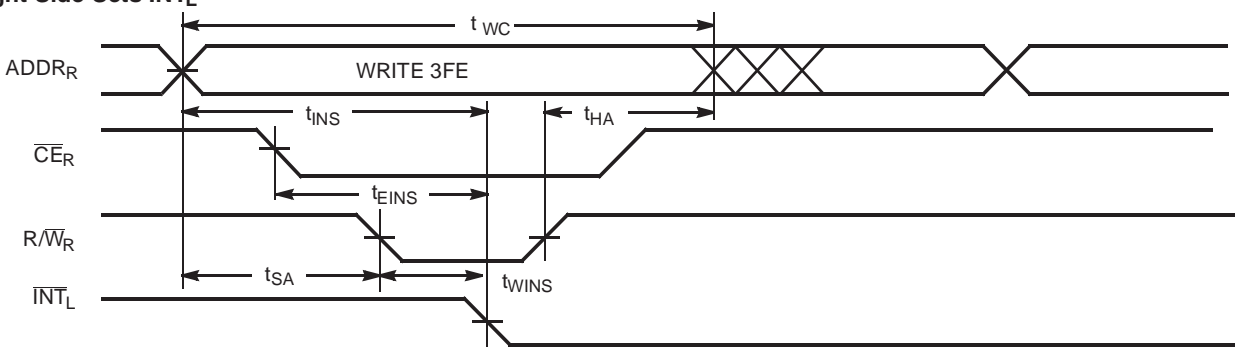

Left Side Clears \overline{INT}_L

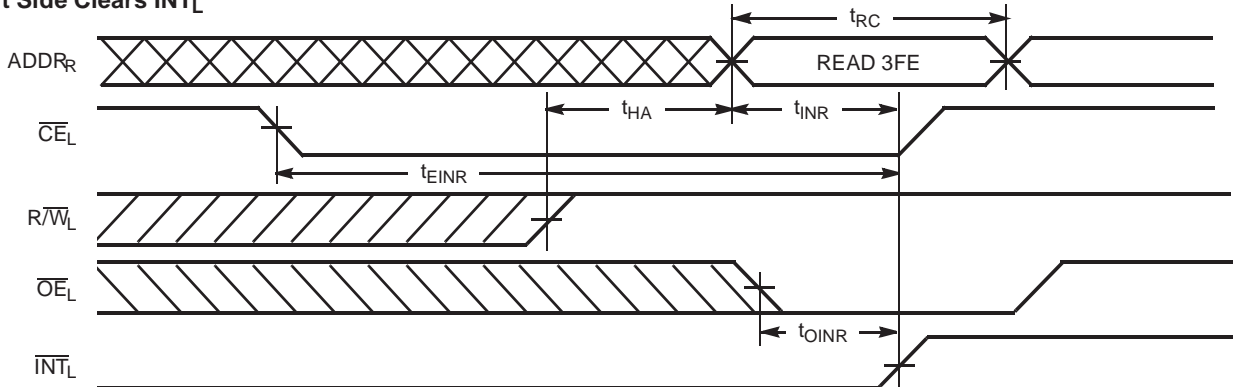

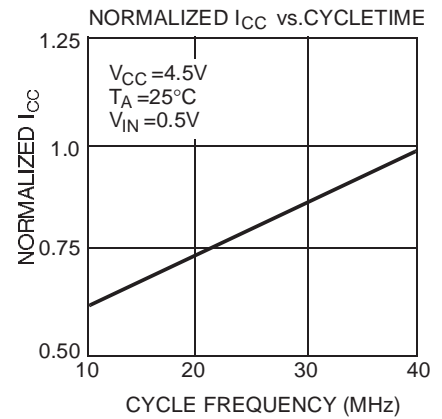
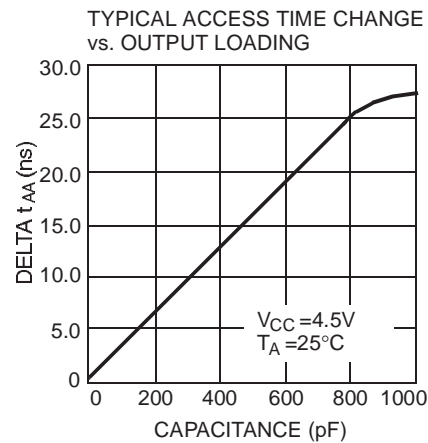
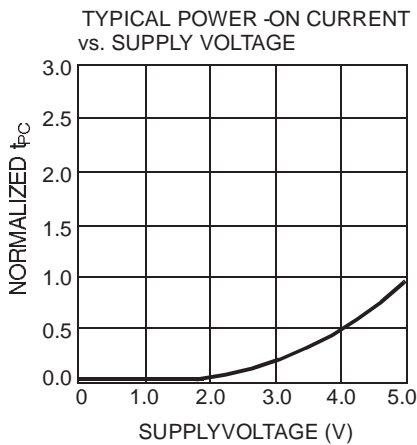
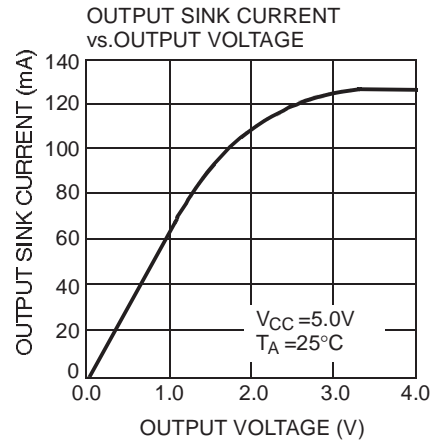
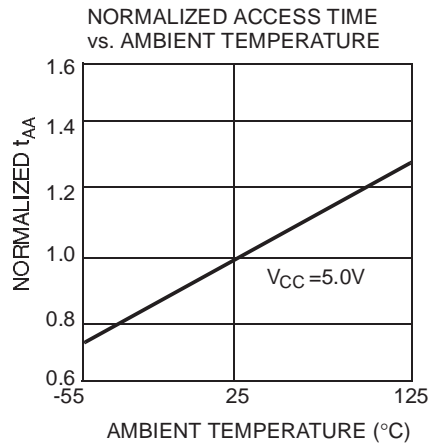
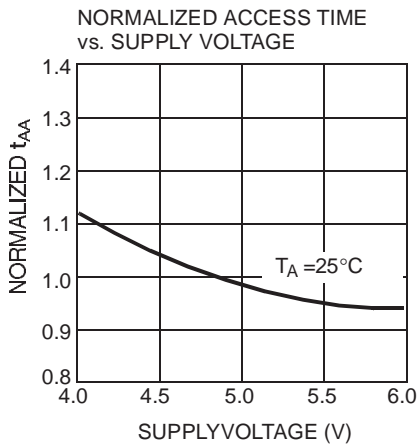
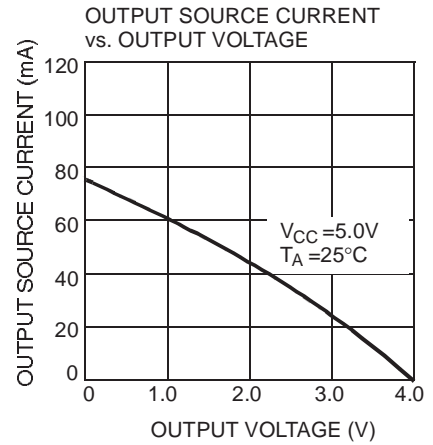
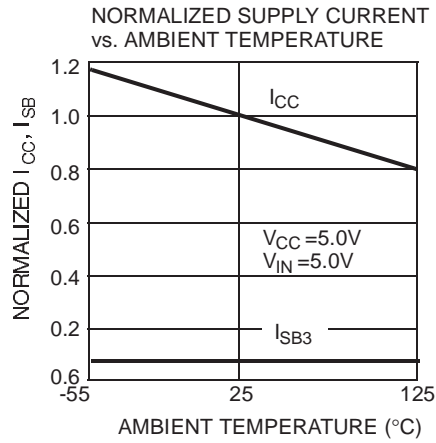
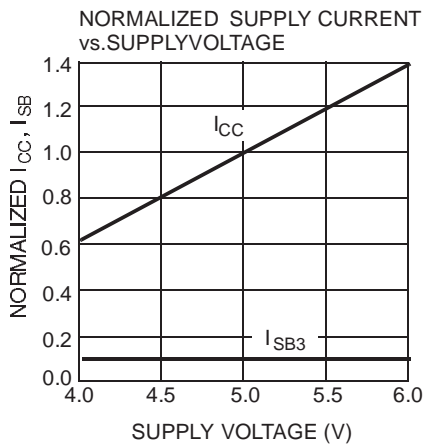
Typical DC and AC Characteristics

Ordering Information

Speed (ns)	Ordering Code	Package Name	Package Type	Operating Range
30	CY7C130-30PC	P25	48-Lead (600-Mil) Molded DIP	Commercial
	CY7C130-30PI	P25	48-Lead (600-Mil) Molded DIP	Industrial
35	CY7C130-35PC	P25	48-Lead (600-Mil) Molded DIP	Commercial
	CY7C130-35PI	P25	48-Lead (600-Mil) Molded DIP	Industrial
	CY7C130-35DMB	D26	48-Lead (600-Mil) Sidebrazed DIP	Military
45	CY7C130-45PC	P25	48-Lead (600-Mil) Molded DIP	Commercial
	CY7C130-45PI	P25	48-Lead (600-Mil) Molded DIP	Industrial
	CY7C130-45DMB	D26	48-Lead (600-Mil) Sidebrazed DIP	Military
55	CY7C130-55PC	P25	48-Lead (600-Mil) Molded DIP	Commercial
	CY7C130-55PI	P25	48-Lead (600-Mil) Molded DIP	Industrial
	CY7C130-55DMB	D26	48-Lead (600-Mil) Sidebrazed DIP	Military

Speed (ns)	Ordering Code	Package Name	Package Type	Operating Range
15	CY7C131-15JC	J69	52-Lead Plastic Leaded Chip Carrier	Commercial
	CY7C131-15NC	N52	52-Pin Plastic Quad Flatpack	
25	CY7C131-25JC	J69	52-Lead Plastic Leaded Chip Carrier	Commercial
	CY7C131-25NC	N52	52-Pin Plastic Quad Flatpack	
	CY7C131-25JI	J69	52-Lead Plastic Leaded Chip Carrier	Industrial
	CY7C131-25NI	N52	52-Pin Plastic Quad Flatpack	
30	CY7C131-30JC	J69	52-Lead Plastic Leaded Chip Carrier	Commercial
	CY7C131-30NC	N52	52-Pin Plastic Quad Flatpack	
	CY7C131-30JI	J69	52-Lead Plastic Leaded Chip Carrier	Industrial
35	CY7C131-35JC	J69	52-Lead Plastic Leaded Chip Carrier	Commercial
	CY7C131-35NC	N52	52-Pin Plastic Quad Flatpack	
	CY7C131-35JI	J69	52-Lead Plastic Leaded Chip Carrier	Industrial
	CY7C131-35NI	N52	52-Pin Plastic Quad Flatpack	
45	CY7C131-45JC	J69	52-Lead Plastic Leaded Chip Carrier	Commercial
	CY7C131-45NC	N52	52-Pin Plastic Quad Flatpack	
	CY7C131-45JI	J69	52-Lead Plastic Leaded Chip Carrier	Industrial
	CY7C131-45NI	N52	52-Pin Plastic Quad Flatpack	
55	CY7C131-55JC	J69	52-Lead Plastic Leaded Chip Carrier	Commercial
	CY7C131-55NC	N52	52-Pin Plastic Quad Flatpack	
	CY7C131-55JI	J69	52-Lead Plastic Leaded Chip Carrier	Industrial
	CY7C131-55NI	N52	52-Pin Plastic Quad Flatpack	

Shaded area contains preliminary information.



Ordering Information (continued)

Speed (ns)	Ordering Code	Package Name	Package Type	Operating Range
30	CY7C140-30PC	P25	48-Lead (600-Mil) Molded DIP	Commercial
	CY7C140-30PI	P25	48-Lead (600-Mil) Molded DIP	Industrial
35	CY7C140-35PC	P25	48-Lead (600-Mil) Molded DIP	Commercial
	CY7C140-35PI	P25	48-Lead (600-Mil) Molded DIP	Industrial
	CY7C140-35DMB	D26	48-Lead (600-Mil) Sidebraze DIP	Military
45	CY7C140-45PC	P25	48-Lead (600-Mil) Molded DIP	Commercial
	CY7C140-45PI	P25	48-Lead (600-Mil) Molded DIP	Industrial
	CY7C140-45DMB	D26	48-Lead (600-Mil) Sidebraze DIP	Military
55	CY7C140-55PC	P25	48-Lead (600-Mil) Molded DIP	Commercial
	CY7C140-55PI	P25	48-Lead (600-Mil) Molded DIP	Industrial
	CY7C140-55DMB	D26	48-Lead (600-Mil) Sidebraze DIP	Military

Speed (ns)	Ordering Code	Package Name	Package Type	Operating Range
15	CY7C141-15JC	J69	52-Lead Plastic Leaded Chip Carrier	Commercial
	CY7C141-15NC	N52	52-Pin Plastic Quad Flatpack	
25	CY7C141-25JC	J69	52-Lead Plastic Leaded Chip Carrier	Commercial
	CY7C141-25NC	N52	52-Pin Plastic Quad Flatpack	
	CY7C141-25JI	J69	52-Lead Plastic Leaded Chip Carrier	Industrial
	CY7C141-25NI	N52	52-Pin Plastic Quad Flatpack	
30	CY7C141-30JC	J69	52-Lead Plastic Leaded Chip Carrier	Commercial
	CY7C141-30NC	N52	52-Pin Plastic Quad Flatpack	Industrial
	CY7C141-30JI	J69	52-Lead Plastic Leaded Chip Carrier	
35	CY7C141-35JC	J69	52-Lead Plastic Leaded Chip Carrier	Commercial
	CY7C141-35NC	N52	52-Pin Plastic Quad Flatpack	Industrial
	CY7C141-35JI	J69	52-Lead Plastic Leaded Chip Carrier	
	CY7C141-35NI	N52	52-Pin Plastic Quad Flatpack	
45	CY7C141-45JC	J69	52-Lead Plastic Leaded Chip Carrier	Commercial
	CY7C141-45NC	N52	52-Pin Plastic Quad Flatpack	Industrial
	CY7C141-45JI	J69	52-Lead Plastic Leaded Chip Carrier	
	CY7C141-45NI	N52	52-Pin Plastic Quad Flatpack	
55	CY7C141-55JC	J69	52-Lead Plastic Leaded Chip Carrier	Commercial
	CY7C141-55NC	N52	52-Pin Plastic Quad Flatpack	Industrial
	CY7C141-55JI	J69	52-Lead Plastic Leaded Chip Carrier	
	CY7C141-55NI	N52	52-Pin Plastic Quad Flatpack	

Shaded area contains preliminary information.

MILITARY SPECIFICATIONS
Group A Subgroup Testing
DC Characteristics

Parameter	Subgroups
V_{OH}	1, 2, 3
V_{OL}	1, 2, 3
V_{IH}	1, 2, 3
V_{IL} Max.	1, 2, 3
I_{IX}	1, 2, 3
I_{OZ}	1, 2, 3
I_{CC}	1, 2, 3
I_{SB1}	1, 2, 3
I_{SB2}	1, 2, 3
I_{SB3}	1, 2, 3
I_{SB4}	1, 2, 3

Switching Characteristics

Parameter	Subgroups
READ CYCLE	
t_{RC}	7, 8, 9, 10, 11
t_{AA}	7, 8, 9, 10, 11
t_{ACE}	7, 8, 9, 10, 11
t_{DOE}	7, 8, 9, 10, 11
WRITE CYCLE	
t_{WC}	7, 8, 9, 10, 11
t_{SCE}	7, 8, 9, 10, 11
t_{AW}	7, 8, 9, 10, 11
t_{HA}	7, 8, 9, 10, 11
t_{SA}	7, 8, 9, 10, 11
t_{PWE}	7, 8, 9, 10, 11
t_{SD}	7, 8, 9, 10, 11
t_{HD}	7, 8, 9, 10, 11

Parameter	Subgroups
BUSY/INTERRUPT TIMING	
t_{BLA}	7, 8, 9, 10, 11
t_{BHA}	7, 8, 9, 10, 11
t_{BLC}	7, 8, 9, 10, 11
t_{BHC}	7, 8, 9, 10, 11
t_{PS}	7, 8, 9, 10, 11
t_{WINS}	7, 8, 9, 10, 11
t_{EINS}	7, 8, 9, 10, 11
t_{INS}	7, 8, 9, 10, 11
t_{OINR}	7, 8, 9, 10, 11
t_{EINR}	7, 8, 9, 10, 11
t_{INR}	7, 8, 9, 10, 11
BUSY TIMING	
$t_{WB}^{[24]}$	7, 8, 9, 10, 11
t_{WH}	7, 8, 9, 10, 11
t_{BDD}	7, 8, 9, 10, 11

Note:

24. CY7C140/CY7C141 only.

Document #: 38-00027-L

Package Diagrams

48-Lead (600-Mil) Sidebrazed DIP D26

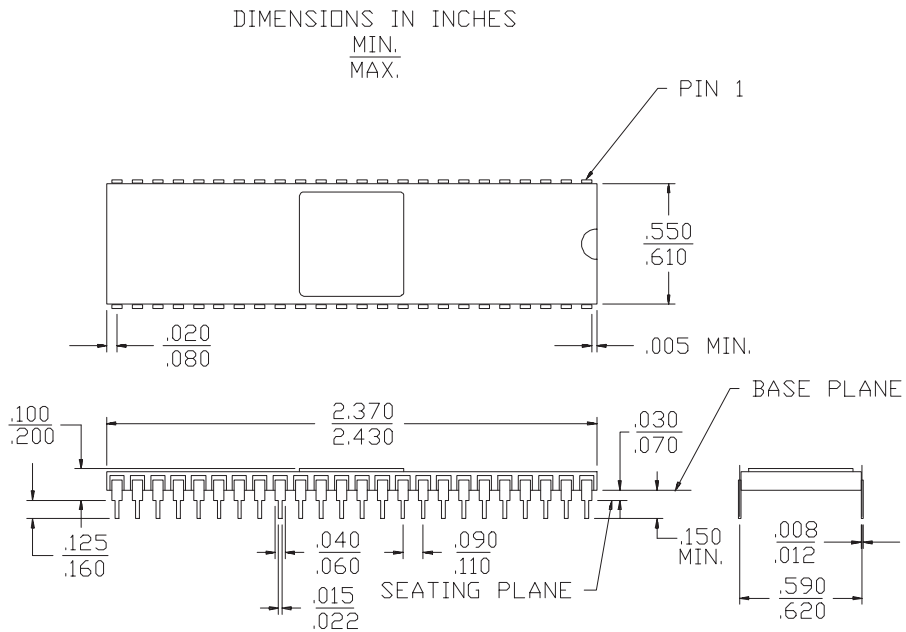

52-Lead Plastic Leaded Chip Carrier J69

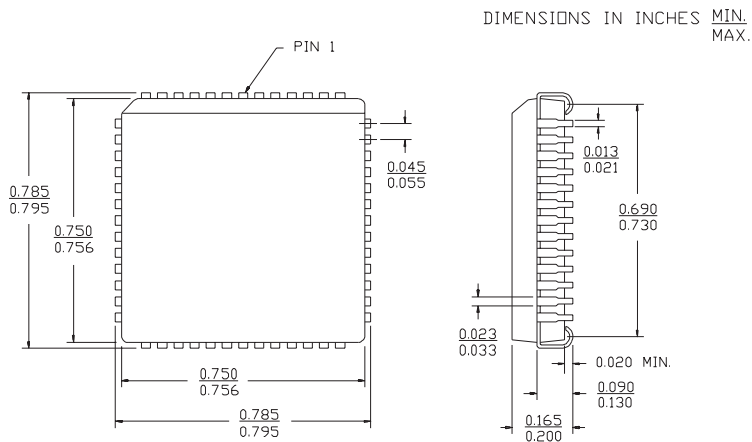

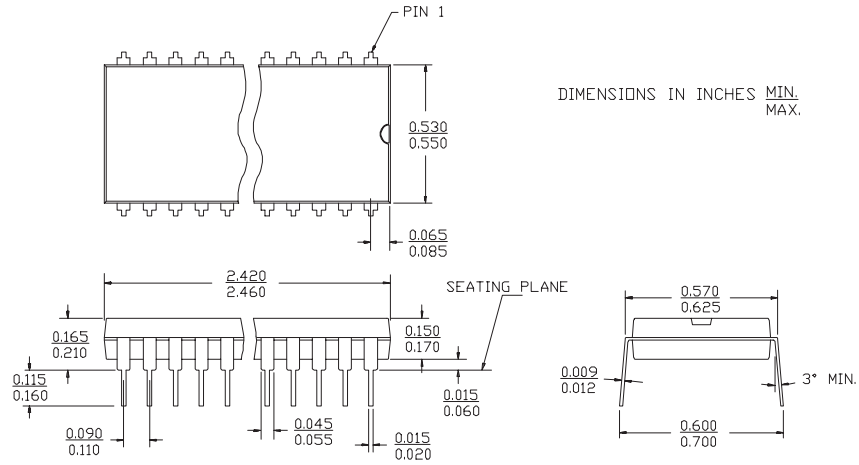

Package Diagrams (continued)

48-Lead (600-Mil) Molded DIP P25



Looking for pricing, stock, or lifecycle information?

Click below to explore more details on WIN SOURCE:

-  [View CY7C131-25JC on WIN SOURCE](#)
-  [Cypress Semiconductor Corp Information](#)

Optimize Your Supply Chain with WIN SOURCE Solutions

-  Global Sourcing Solution
-  Obsolete Management
-  Cost Control Management
-  Shortage Management
-  Alternative Solution
-  Excess Inventory Management