



**THE DATASHEET OF  
CY7C1303BV25-167BZC**



# 18-Mbit Burst of Two-Pipelined SRAM with QDR® Architecture

## Features

- Separate independent read and write data ports
  - Supports concurrent transactions
- 167 MHz clock for high bandwidth
  - 2.5 ns clock-to-valid access time
- Two word burst on all accesses
- Double data rate (DDR) interfaces on both read and write ports (data transferred at 333 MHz) at 167 MHz
- Two input clocks (K and  $\bar{K}$ ) for precise DDR timing
  - SRAM uses rising edges only
- Two input clocks for output data (C and  $\bar{C}$ ) to minimize clock skew and flight time mismatches.
- Single multiplexed address input bus latches address inputs for both read and write ports
- Separate port selects for depth expansion
- Synchronous internally self-timed writes
- 2.5 V core power supply with HSTL inputs and outputs
- Available in 165-ball FBGA package (13 × 15 × 1.4 mm)
- Variable drive HSTL output buffers
- Expanded HSTL output voltage (1.4 V to 1.9 V)
- JTAG Interface
- Variable Impedance HSTL

## Configurations

CY7C1303BV25 – 1M × 18

## Selection Guide

Description	CY7C1303BV25-167	Unit
Maximum operating frequency	167	MHz
Maximum operating current	500	mA

## Functional Description

The CY7C1303BV25 is 2.5 V synchronous pipelined SRAM equipped with QDR® architecture. QDR architecture consists of two separate ports to access the memory array. The read port has dedicated data outputs to support read operations and the write port has dedicated data inputs to support write operations. Access to each port is accomplished through a common address bus. The Read address is latched on the rising edge of the K clock and the Write address is latched on the rising edge of  $\bar{K}$  clock. QDR has separate data inputs and data outputs to completely eliminate the need to “turn around” the data bus required with common I/O devices. Accesses to the CY7C1303BV25 Read and Write ports are completely independent of one another. All accesses are initiated synchronously on the rising edge of the positive input clock (K). In order to maximize data throughput, both Read and Write ports are equipped with Double Data Rate (DDR) interfaces. Therefore, data can be transferred into the device on every rising edge of both input clocks (K and  $\bar{K}$ ) and out of the device on every rising edge of the output clock (C and  $\bar{C}$ , or K and  $\bar{K}$  when in single clock mode) thereby maximizing performance while simplifying system design. Each address location is associated with two 18-bit words (CY7C1303BV25) that burst sequentially into or out of the device.

Depth expansion is accomplished with a port select input for each port. Each Port Selects allow each port to operate independently.

All synchronous inputs pass through input registers controlled by the K or  $\bar{K}$  input clocks. All data outputs pass through output registers controlled by the C or  $\bar{C}$  input clocks. Writes are conducted with on-chip synchronous self-timed write circuitry.

For a complete list of related documentation, click [here](#).

Logic Block Diagram – CY7C1303BV25

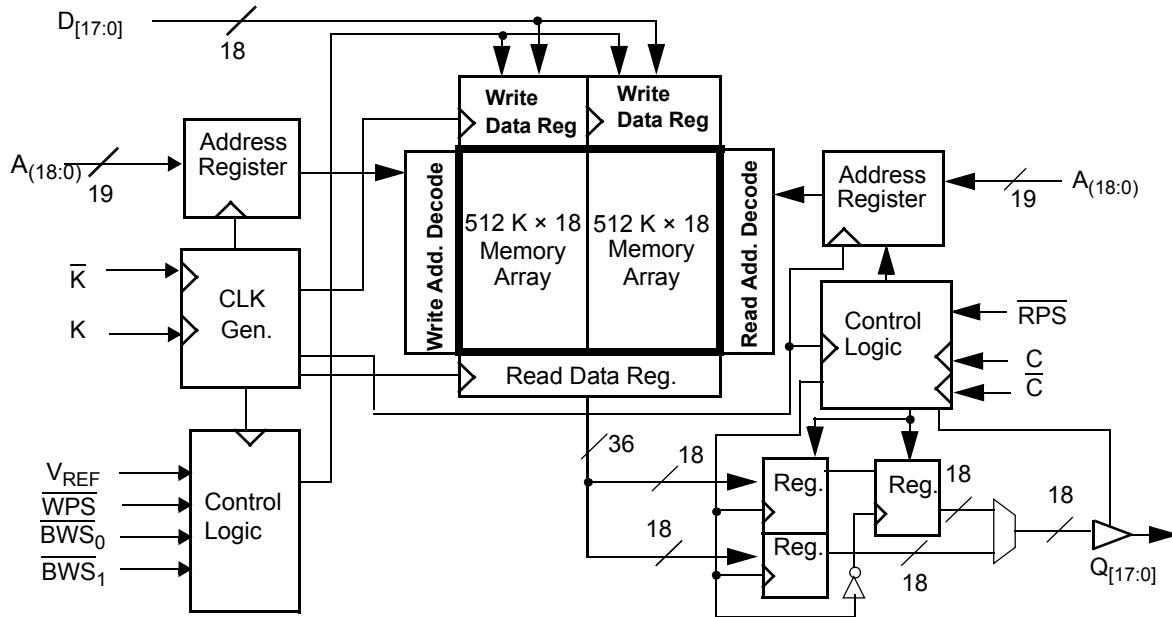

## Contents

<b>Pin Configuration</b> .....	<b>4</b>	<b>Instruction Codes</b> .....	<b>15</b>
<b>Pin Definitions</b> .....	<b>5</b>	<b>Boundary Scan Order</b> .....	<b>16</b>
<b>Functional Overview</b> .....	<b>6</b>	<b>Maximum Ratings</b> .....	<b>17</b>
Read Operations .....	6	<b>Operating Range</b> .....	<b>17</b>
Write Operations .....	6	<b>Neutron Soft Error Immunity</b> .....	<b>17</b>
Byte Write Operations .....	6	<b>Electrical Characteristics</b> .....	<b>17</b>
Single Clock Mode .....	6	DC Electrical Characteristics .....	17
Concurrent Transactions .....	6	AC Electrical Characteristics .....	18
Depth Expansion .....	6	<b>Thermal Resistance</b> .....	<b>18</b>
Programmable Impedance .....	7	<b>Capacitance</b> .....	<b>18</b>
<b>Application Example</b> .....	<b>7</b>	<b>AC Test Loads and Waveforms</b> .....	<b>18</b>
<b>Truth Table</b> .....	<b>8</b>	<b>Switching Characteristics</b> .....	<b>19</b>
<b>Write Cycle Descriptions</b> .....	<b>8</b>	<b>Switching Waveforms</b> .....	<b>20</b>
<b>IEEE 1149.1 Serial Boundary Scan (JTAG)</b> .....	<b>9</b>	<b>Ordering Information</b> .....	<b>21</b>
Disabling the JTAG Feature .....	9	Ordering Code Definitions .....	21
Test Access Port .....	9	<b>Package Diagram</b> .....	<b>22</b>
Performing a TAP Reset .....	9	<b>Acronyms</b> .....	<b>23</b>
TAP Registers .....	9	<b>Document Conventions</b> .....	<b>23</b>
TAP Instruction Set .....	9	Units of Measure .....	23
<b>TAP Controller State Diagram</b> .....	<b>11</b>	<b>Document History Page</b> .....	<b>24</b>
<b>TAP Controller Block Diagram</b> .....	<b>12</b>	<b>Sales, Solutions, and Legal Information</b> .....	<b>26</b>
<b>TAP Electrical Characteristics</b> .....	<b>12</b>	Worldwide Sales and Design Support .....	26
<b>TAP AC Switching Characteristics</b> .....	<b>13</b>	Products .....	26
<b>TAP Timing and Test Conditions</b> .....	<b>14</b>	PSoC@Solutions .....	26
<b>Identification Register Definitions</b> .....	<b>15</b>	Cypress Developer Community .....	26
<b>Scan Register Sizes</b> .....	<b>15</b>	Technical Support .....	26

## Pin Configuration

Figure 1. 165-ball FBGA (13 × 15 × 1.4 mm) pinout

CY7C1303BV25 (1M × 18)

	1	2	3	4	5	6	7	8	9	10	11
<b>A</b>	NC	Gnd/144 M	NC/36 M	$\overline{WPS}$	$\overline{BWS}_1$	$\overline{K}$	NC	$\overline{RPS}$	A	Gnd/72 M	NC
<b>B</b>	NC	Q9	D9	A	NC	K	$\overline{BWS}_0$	A	NC	NC	Q8
<b>C</b>	NC	NC	D10	$V_{SS}$	A	A	A	$V_{SS}$	NC	Q7	D8
<b>D</b>	NC	D11	Q10	$V_{SS}$	$V_{SS}$	$V_{SS}$	$V_{SS}$	$V_{SS}$	NC	NC	D7
<b>E</b>	NC	NC	Q11	$V_{DDQ}$	$V_{SS}$	$V_{SS}$	$V_{SS}$	$V_{DDQ}$	NC	D6	Q6
<b>F</b>	NC	Q12	D12	$V_{DDQ}$	$V_{DD}$	$V_{SS}$	$V_{DD}$	$V_{DDQ}$	NC	NC	Q5
<b>G</b>	NC	D13	Q13	$V_{DDQ}$	$V_{DD}$	$V_{SS}$	$V_{DD}$	$V_{DDQ}$	NC	NC	D5
<b>H</b>	NC	$V_{REF}$	$V_{DDQ}$	$V_{DDQ}$	$V_{DD}$	$V_{SS}$	$V_{DD}$	$V_{DDQ}$	$V_{DDQ}$	$V_{REF}$	ZQ
<b>J</b>	NC	NC	D14	$V_{DDQ}$	$V_{DD}$	$V_{SS}$	$V_{DD}$	$V_{DDQ}$	NC	Q4	D4
<b>K</b>	NC	NC	Q14	$V_{DDQ}$	$V_{DD}$	$V_{SS}$	$V_{DD}$	$V_{DDQ}$	NC	D3	Q3
<b>L</b>	NC	Q15	D15	$V_{DDQ}$	$V_{SS}$	$V_{SS}$	$V_{SS}$	$V_{DDQ}$	NC	NC	Q2
<b>M</b>	NC	NC	D16	$V_{SS}$	$V_{SS}$	$V_{SS}$	$V_{SS}$	$V_{SS}$	NC	Q1	D2
<b>N</b>	NC	D17	Q16	$V_{SS}$	A	A	A	$V_{SS}$	NC	NC	D1
<b>P</b>	NC	NC	Q17	A	A	C	A	A	NC	D0	Q0
<b>R</b>	TDO	TCK	A	A	A	C	A	A	A	TMS	TDI

## Pin Definitions

Name	I/O	Description
$D_{[x:0]}$	Input-Synchronous	<b>Data input signals, sampled on the rising edge of K and <math>\bar{K}</math> clocks during valid write operations.</b> CY7C1303BV25 – $D_{[17:0]}$
WPS	Input-Synchronous	<b>Write Port Select, active LOW.</b> Sampled on the rising edge of the K clock. When asserted active, a Write operation is initiated. Deasserting deselects the Write port. Deselecting the Write port causes $D_{[x:0]}$ to be ignored.
$\overline{BWS}_0$ , $\overline{BWS}_1$	Input-Synchronous	<b>Byte Write Select 0 and 1- active LOW.</b> Sampled on the rising edge of the K and $\bar{K}$ clocks during Write operations. Used to select which byte is written into the device during the current portion of the Write operations. CY7C1303BV25 - $\overline{BWS}_0$ controls $D_{[8:0]}$ and $\overline{BWS}_1$ controls $D_{[17:9]}$ . Bytes not written remain unaltered. Deselecting a Byte Write Select causes the corresponding byte of data to be ignored and not written into the device.
A	Input-Synchronous	<b>Address Inputs.</b> Sampled on the rising edge of the K clock during active Read operations and on the rising edge of $\bar{K}$ for Write operations. These address inputs are multiplexed for both Read and Write operations. Internally, the device is organized as $1M \times 18$ (2 arrays each of $512K \times 18$ ) for CY7C1303BV25. Therefore, only 19 address inputs are needed to access the entire memory array of CY7C1303BV25. These inputs are ignored when the appropriate port is deselected.
$Q_{[x:0]}$	Outputs-Synchronous	<b>Data Output signals.</b> These pins drive out the requested data during a Read operation. Valid data is driven out on the rising edge of both the C and $\bar{C}$ clocks during Read operations or K and $\bar{K}$ when in single clock mode. When the Read port is deselected, $Q_{[x:0]}$ are automatically three-stated. CY7C1303BV25 - $Q_{[17:0]}$
RPS	Input-Synchronous	<b>Read Port Select, active LOW.</b> Sampled on the rising edge of positive input clock (K). When active, a Read operation is initiated. Deasserting causes the Read port to be deselected. When deselected, the pending access is allowed to complete and the output drivers are automatically three-stated following the next rising edge of the K clock. Each read access consists of a burst of two sequential 18-bit transfers.
C	Input-Clock	<b>Positive Input Clock for Output Data.</b> C is used in conjunction with $\bar{C}$ to clock out the Read data from the device. C and $\bar{C}$ can be used together to deskew the flight times of various devices on the board back to the controller. See application example for further details.
$\bar{C}$	Input-Clock	<b>Negative Input Clock for Output Data.</b> $\bar{C}$ is used in conjunction with C to clock out the Read data from the device. C and $\bar{C}$ can be used together to deskew the flight times of various devices on the board back to the controller. See application example for further details.
K	Input-Clock	<b>Positive Input Clock Input.</b> The rising edge of K is used to capture synchronous inputs to the device and to drive out data through $Q_{[x:0]}$ when in single clock mode. All accesses are initiated on the rising edge of K.
$\bar{K}$	Input-Clock	<b>Negative Input Clock Input.</b> $\bar{K}$ is used to capture synchronous inputs to the device and to drive out data through $Q_{[x:0]}$ when in single clock mode.
ZQ	Input	<b>Output Impedance Matching Input.</b> This input is used to tune the device outputs to the system data bus impedance. $Q_{[x:0]}$ output impedance are set to $0.2 \times RQ$ , where RQ is a resistor connected between ZQ and ground. Alternately, this pin can be connected directly to $V_{DDQ}$ , which enables the minimum impedance mode. This pin cannot be connected directly to GND or left unconnected.
TDO	Output	<b>TDO pin for JTAG.</b>
TCK	Input	<b>TCK pin for JTAG.</b>
TDI	Input	<b>TDI pin for JTAG.</b>
TMS	Input	<b>TMS pin for JTAG.</b>
NC/36M	N/A	<b>Address expansion for 36M.</b> This pin is not connected to the die and so can be tied to any voltage level on CY7C1303BV25
GND/72M	Input	<b>Address expansion for 72M.</b> This pin has to be tied to GND on CY7C1303BV25.
GND/144M	Input	<b>Address expansion for 144M.</b> This pin has to be tied to GND on CY7C1303BV25.
NC	N/A	<b>Not connected to the die.</b> Can be tied to any voltage level.

## Pin Definitions (continued)

Name	I/O	Description
V <sub>REF</sub>	Input-Reference	<b>Reference Voltage Input.</b> Static input used to set the reference level for HSTL inputs and Outputs as well as AC measurement points.
V <sub>DD</sub>	Power Supply	<b>Power supply inputs to the core of the device.</b>
V <sub>SS</sub>	Ground	<b>Ground for the device.</b>
V <sub>DDQ</sub>	Power Supply	<b>Power supply inputs for the outputs of the device.</b>

## Functional Overview

The CY7C1303BV25 are synchronous pipelined Burst SRAM equipped with both a Read port and a Write port. The Read port is dedicated to Read operations and the Write port is dedicated to Write operations. Data flows into the SRAM through the Write port and out through the Read port. These devices multiplex the address inputs in order to minimize the number of address pins required. By having separate Read and Write ports, this architecture completely eliminates the need to “turn-around” the data bus and avoids any possible data contention, thereby simplifying system design. Each access consists of two 18-bit data transfers in the case of CY7C1303BV25, in one clock cycle.

Accesses for both ports are initiated on the rising edge of the Positive Input Clock (K). All synchronous input timing is referenced from the rising edge of the input clocks (K and  $\bar{K}$ ) and all output timings are referenced to rising edge of output clocks (C and  $\bar{C}$  or K and  $\bar{K}$  when in single clock mode).

All synchronous data inputs ( $D_{[x:0]}$ ) pass through input registers controlled by the rising edge of the input clocks (K and  $\bar{K}$ ). All synchronous data outputs ( $Q_{[x:0]}$ ) pass through output registers controlled by the rising edge of the output clocks (C and  $\bar{C}$ , or K and  $\bar{K}$  when in single clock mode).

All synchronous control ( $\bar{RPS}$ ,  $\bar{WPS}$ ,  $\bar{BWS}_{[x:0]}$ ) inputs pass through input registers controlled by the rising edge of input clocks (K and  $\bar{K}$ ).

The following descriptions take CY7C1303BV25 as an example.

### Read Operations

The CY7C1303BV25 is organized internally as 2 arrays of 512K × 18. Accesses are completed in a burst of two sequential 18-bit data words. Read operations are initiated by asserting  $\bar{RPS}$  active at the rising edge of the positive input clock (K). The address is latched on the rising edge of the K clock. Following the next K clock rise the corresponding lower order 18-bit word of data is driven onto the  $Q_{[17:0]}$  using C as the output timing reference. On the subsequent rising edge of  $\bar{C}$  the higher order data word is driven onto the  $Q_{[17:0]}$ . The requested data is valid 2.5 ns from the rising edge of the output clock (C and  $\bar{C}$ , or K and  $\bar{K}$  when in single clock mode, 167 MHz device).

Synchronous internal circuitry automatically three-states the outputs following the next rising edge of the positive output clock (C). This allows for a seamless transition between devices without the insertion of wait states in a depth expanded memory.

### Write Operations

Write operations are initiated by asserting  $\bar{WPS}$  active at the rising edge of the positive input clock (K). On the same K clock rise the data presented to  $D_{[17:0]}$  is latched and stored into the

lower 18-bit Write Data register provided  $\bar{BWS}_{[1:0]}$  are both asserted active. On the subsequent rising edge of the negative input clock ( $\bar{K}$ ), the address is latched and the information presented to  $D_{[17:0]}$  is stored into the Write Data register provided  $\bar{BWS}_{[1:0]}$  are both asserted active. The 36-bits of data are then written into the memory array at the specified location.

When deselected, the Write port ignores all inputs after the pending Write operations have been completed.

### Byte Write Operations

Byte Write operations are supported by the CY7C1303BV25. A Write operation is initiated as described in the Write Operation section above. The bytes that are written are determined by  $\bar{BWS}_0$  and  $\bar{BWS}_1$  which are sampled with each set of 18-bit data word. Asserting the appropriate Byte Write Select input during the data portion of a write allows the data being presented to be latched and written into the device. Deasserting the Byte Write Select input during the data portion of a write allows the data stored in the device for that byte to remain unaltered. This feature can be used to simplify Read/Modify/Write operations to a Byte Write operation.

### Single Clock Mode

The CY7C1303BV25 can be used with a single clock mode. In this mode the device recognizes only the pair of input clocks (K and  $\bar{K}$ ) that control both the input and output registers. This operation is identical to the operation if the device had zero skew between the  $K/\bar{K}$  and  $C/\bar{C}$  clocks. All timing parameters remain the same in this mode. To use this mode of operation, the user must tie C and  $\bar{C}$  HIGH at power-up. This function is a strap option and not alterable during device operation.

### Concurrent Transactions

The Read and Write ports on the CY7C1303BV25 operate completely independently of one another. Since each port latches the address inputs on different clock edges, the user can Read or Write to any location, regardless of the transaction on the other port. Also, reads and writes can be started in the same clock cycle. If the ports access the same location at the same time, the SRAM delivers the most recent information associated with the specified address location. This includes forwarding data from a Write cycle that was initiated on the previous K clock rise.

### Depth Expansion

The CY7C1303BV25 has a Port Select input for each port. This allows for easy depth expansion. Both Port Selects are sampled on the rising edge of the Positive Input Clock only (K). Each port select input can deselect the specified port. Deselecting a port

does not affect the other port. All pending transactions (Read and Write) are completed prior to the device being deselected.

**Programmable Impedance**

An external resistor, RQ, must be connected between the ZQ pin on the SRAM and V<sub>SS</sub> to allow the SRAM to adjust its output

driver impedance. The value of RQ must be 5 × the value of the intended line impedance driven by the SRAM, The allowable range of RQ to guarantee impedance matching with a tolerance of ±15% is between 175 Ω and 350 Ω, with V<sub>DDQ</sub> = 1.5 V. The output impedance is adjusted every 1024 cycles to account for drifts in supply voltage and temperature.

**Application Example**

Figure 2 shows four QDR I used in an application.

**Figure 2. Application Example**

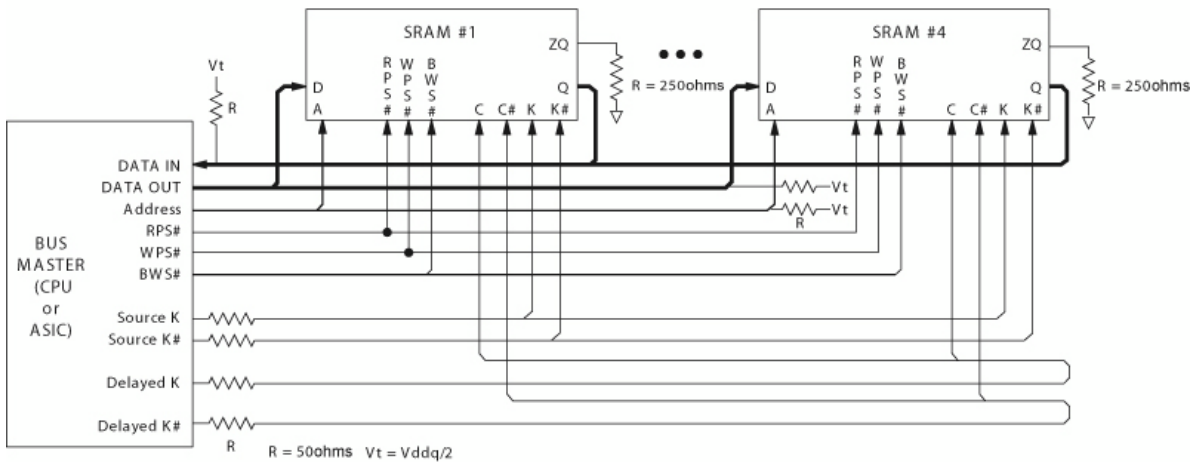

## Truth Table

The truth table for CY7C1303BV25 follow. [1, 2, 3, 4, 5, 6]

Operation	K	RPS	WPS	DQ	DQ
Write cycle: Load address on the rising edge of $\bar{K}$ clock; input write data on K and $\bar{K}$ rising edges.	L–H	X	L	D(A+0) at K(t) ↑	$\bar{D}(A+1)$ at $\bar{K}(t)$ ↑
Read cycle: Load address on the rising edge of K clock; wait one cycle; read data on 2 consecutive C and $\bar{C}$ rising edges.	L–H	L	X	Q(A+0) at C(t+1) ↑	$\bar{Q}(A+1)$ at $\bar{C}(t+1)$ ↑
NOP: No operation	L–H	H	H	D = X Q = High Z	D = X Q = High Z
Standby: Clock stopped	Stopped	X	X	Previous state	Previous state

## Write Cycle Descriptions

The write cycle description table for CY7C1303BV25 follow. [7, 8]

$\overline{BWS}_0$	$\overline{BWS}_1$	K	$\bar{K}$	Comments
L	L	L–H	–	During the data portion of a Write sequence, both bytes ( $D_{[17:0]}$ ) are written into the device.
L	L	–	L–H	During the data portion of a Write sequence, both bytes ( $D_{[17:0]}$ ) are written into the device.
L	H	L–H	–	During the data portion of a Write sequence, only the lower byte ( $D_{[8:0]}$ ) is written into the device. $D_{[17:9]}$ remains unaltered.
L	H	–	L–H	During the data portion of a Write sequence, only the lower byte ( $D_{[8:0]}$ ) is written into the device. $D_{[17:9]}$ remains unaltered.
H	L	L–H	–	During the data portion of a Write sequence, only the byte ( $D_{[17:9]}$ ) is written into the device. $D_{[8:0]}$ remains unaltered.
H	L	–	L–H	During the data portion of a Write sequence, only the byte ( $D_{[17:9]}$ ) is written into the device. $D_{[8:0]}$ remains unaltered.
H	H	L–H	–	No data is written into the device during this portion of a write operation.
H	H	–	L–H	No data is written into the device during this portion of a write operation.

### Notes

- X = Do not Care, H = Logic HIGH, L = Logic LOW, ↑ represents rising edge.
- Device power-ups deselected and the outputs in a three-state condition.
- "A" represents address location latched by the devices when transaction was initiated. A + 0, A + 1 represent the addresses sequence in the burst.
- "t" represents the cycle at which a Read/Write operation is started. t+1 is the first clock cycle succeeding the "t" clock cycle.
- Data inputs are registered at K and  $\bar{K}$  rising edges. Data outputs are delivered on C and  $\bar{C}$  rising edges, except when in single clock mode.
- It is recommended that  $K = \bar{K}$  and  $C = \bar{C}$  when clock is stopped. This is not essential, but permits most rapid restart by overcoming transmission line charging symmetrically.
- X = Do not Care, H = Logic HIGH, L = Logic LOW, ↑ represents rising edge.
- Assumes a Write cycle was initiated per the Write Port Cycle Description Truth Table.  $\overline{BWS}_0$ ,  $\overline{BWS}_1$ , in the case of CY7C1303BV25 can be altered on different portions of a write cycle, as long as the setup and hold requirements are achieved.

## IEEE 1149.1 Serial Boundary Scan (JTAG)

These SRAMs incorporate a serial boundary scan test access port (TAP) in the FBGA package. This part is fully compliant with IEEE Standard #1149.1 to 1900. The TAP operates using JEDEC standard 2.5 V I/O logic levels.

### Disabling the JTAG Feature

It is possible to operate the SRAM without using the JTAG feature. To disable the TAP controller, TCK must be tied LOW ( $V_{SS}$ ) to prevent clocking of the device. TDI and TMS are internally pulled up and may be unconnected. They may alternately be connected to  $V_{DD}$  through a pull-up resistor. TDO should be left unconnected. Upon power-up, the device comes up in a reset state which does not interfere with the operation of the device.

### Test Access Port

#### Test Clock

The test clock is used only with the TAP controller. All inputs are captured on the rising edge of TCK. All outputs are driven from the falling edge of TCK.

#### Test Mode Select

The TMS input is used to give commands to the TAP controller and is sampled on the rising edge of TCK. It is allowable to leave this pin unconnected if the TAP is not used. The pin is pulled up internally, resulting in a logic HIGH level.

#### Test Data-In (TDI)

The TDI pin is used to serially input information into the registers and can be connected to the input of any of the registers. The register between TDI and TDO is chosen by the instruction that is loaded into the TAP instruction register. For information on loading the instruction register, see the [TAP Controller State Diagram on page 11](#). TDI is internally pulled up and can be unconnected if the TAP is unused in an application. TDI is connected to the most significant bit (MSB) on any register.

#### Test Data-Out (TDO)

The TDO output pin is used to serially clock data-out from the registers. The output is active depending upon the current state of the TAP state machine (see [Instruction Codes on page 15](#)). The output changes on the falling edge of TCK. TDO is connected to the least significant bit (LSB) of any register.

### Performing a TAP Reset

A Reset is performed by forcing TMS HIGH ( $V_{DD}$ ) for five rising edges of TCK. This RESET does not affect the operation of the SRAM and may be performed while the SRAM is operating. At power-up, the TAP is reset internally to ensure that TDO comes up in a High Z state.

### TAP Registers

Registers are connected between the TDI and TDO pins to scan the data in and out of the SRAM test circuitry. Only one register can be selected at a time through the instruction registers. Data is serially loaded into the TDI pin on the rising edge of TCK. Data is output on the TDO pin on the falling edge of TCK.

#### Instruction Register

Three-bit instructions can be serially loaded into the instruction register. This register is loaded when it is placed between the TDI and TDO pins as shown in [TAP Controller Block Diagram on page 12](#). Upon power-up, the instruction register is loaded with the IDCODE instruction. It is also loaded with the IDCODE instruction if the controller is placed in a reset state as described in the previous section.

When the TAP controller is in the Capture IR state, the two least significant bits are loaded with a binary "01" pattern to allow for fault isolation of the board level serial test path.

#### Bypass Register

To save time when serially shifting data through registers, it is sometimes advantageous to skip certain chips. The bypass register is a single-bit register that can be placed between TDI and TDO pins. This allows data to be shifted through the SRAM with minimal delay. The bypass register is set LOW ( $V_{SS}$ ) when the BYPASS instruction is executed.

#### Boundary Scan Register

The boundary scan register is connected to all of the input and output pins on the SRAM. Several no connect (NC) pins are also included in the scan register to reserve pins for higher density devices.

The boundary scan register is loaded with the contents of the RAM Input and Output ring when the TAP controller is in the Capture-DR state and is then placed between the TDI and TDO pins when the controller is moved to the Shift-DR state. The EXTEST, SAMPLE/PRELOAD and SAMPLE Z instructions can be used to capture the contents of the Input and Output ring.

The [Boundary Scan Order on page 16](#) show the order in which the bits are connected. Each bit corresponds to one of the bumps on the SRAM package. The MSB of the register is connected to TDI, and the LSB is connected to TDO.

#### Identification (ID) Register

The ID register is loaded with a vendor specific, 32-bit code during the Capture-DR state when the IDCODE command is loaded in the instruction register. The IDCODE is hardwired into the SRAM and can be shifted out when the TAP controller is in the Shift-DR state. The ID register has a vendor code and other information described in the [Identification Register Definitions on page 15](#).

### TAP Instruction Set

Eight different instructions are possible with the three-bit instruction register. All combinations are listed in the [Instruction Codes on page 15](#). Three of these instructions are listed as RESERVED and should not be used. The other five instructions are described in detail below.

Instructions are loaded into the TAP controller during the Shift-IR state when the instruction register is placed between TDI and TDO. During this state, instructions are shifted through the instruction register through the TDI and TDO pins. To execute the instruction after it is shifted in, the TAP controller needs to be moved into the Update-IR state.

### *IDCODE*

The IDCODE instruction causes a vendor specific, 32-bit code to be loaded into the instruction register. It also places the instruction register between the TDI and TDO pins and allows the IDCODE to be shifted out of the device when the TAP controller enters the Shift-DR state. The IDCODE instruction is loaded into the instruction register upon power-up or whenever the TAP controller is given a test logic reset state.

### *SAMPLE Z*

The SAMPLE Z instruction causes the boundary scan register to be connected between the TDI and TDO pins when the TAP controller is in a Shift-DR state. The SAMPLE Z command puts the output bus into a High Z state until the next command is given during the "Update IR" state.

### *SAMPLE/PRELOAD*

SAMPLE/PRELOAD is a 1149.1 mandatory instruction. When the SAMPLE/PRELOAD instructions are loaded into the instruction register and the TAP controller is in the Capture-DR state, a snapshot of data on the inputs and output pins is captured in the boundary scan register.

The user must be aware that the TAP controller clock can only operate at a frequency up to 10 MHz, while the SRAM clock operates more than an order of magnitude faster. Because there is a large difference in the clock frequencies, it is possible that during the Capture-DR state, an input or output undergoes a transition. The TAP may then try to capture a signal while in transition (metastable state). This does not harm the device, but there is no guarantee as to the value that are captured. Repeatable results may not be possible.

To guarantee that the boundary scan register captures the correct value of a signal, the SRAM signal must be stabilized long enough to meet the TAP controller's capture setup plus hold times ( $t_{CS}$  and  $t_{CH}$ ). The SRAM clock input might not be captured correctly if there is no way in a design to stop (or slow) the clock during a SAMPLE/PRELOAD instruction. If this is an issue, it is still possible to capture all other signals and simply ignore the value of the CK and  $\overline{CK}$  captured in the boundary scan register.

After the data is captured, it is possible to shift out the data by putting the TAP into the Shift-DR state. This places the boundary scan register between the TDI and TDO pins.

PRELOAD allows an initial data pattern to be placed at the latched parallel outputs of the boundary scan register cells prior to the selection of another boundary scan test operation.

The shifting of data for the SAMPLE and PRELOAD phases can occur concurrently when required, that is, while data captured is shifted out, the preloaded data can be shifted in.

### *BYPASS*

When the BYPASS instruction is loaded in the instruction register and the TAP is placed in a Shift-DR state, the bypass register is placed between the TDI and TDO pins. The advantage of the BYPASS instruction is that it shortens the boundary scan path when multiple devices are connected together on a board.

### *EXTEST*

The EXTEST instruction enables the preloaded data to be driven out through the system output pins. This instruction also selects the boundary scan register to be connected for serial access between the TDI and TDO in the shift-DR controller state.

#### *EXTEST Output Bus Tri-state*

IEEE Standard 1149.1 mandates that the TAP controller be able to put the output bus into a tri-state mode.

The boundary scan register has a special bit located at bit #47. When this scan cell, called the "extest output bus tri-state", is latched into the preload register during the "Update-DR" state in the TAP controller, it directly controls the state of the output (Q-bus) pins, when the EXTEST is entered as the current instruction. When HIGH, it enables the output buffers to drive the output bus. When LOW, this bit places the output bus into a High Z condition.

This bit can be set by entering the SAMPLE/PRELOAD or EXTEST command, and then shifting the desired bit into that cell, during the "Shift-DR" state. During "Update-DR", the value loaded into that shift-register cell latches into the preload register. When the EXTEST instruction is entered, this bit directly controls the output Q-bus pins. Note that this bit is pre-set HIGH to enable the output when the device is powered-up, and also when the TAP controller is in the "Test-Logic-Reset" state.

### *Reserved*

These instructions are not implemented but are reserved for future use. Do not use these instructions.

## TAP Controller State Diagram

The state diagram for the TAP controller follows. <sup>[9]</sup>

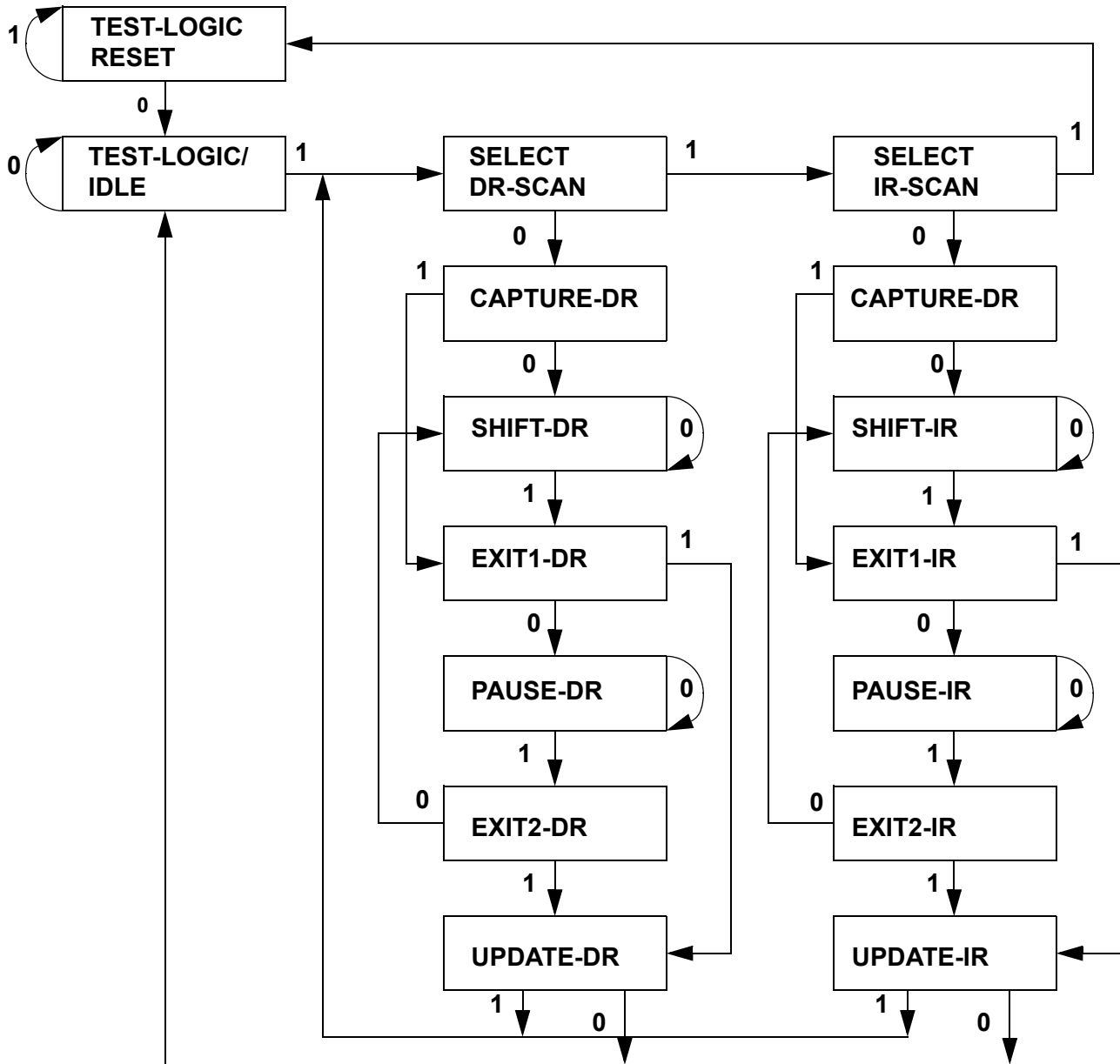

**Note**

9. The 0/1 next to each state represents the value at TMS at the rising edge of TCK.

## TAP Controller Block Diagram

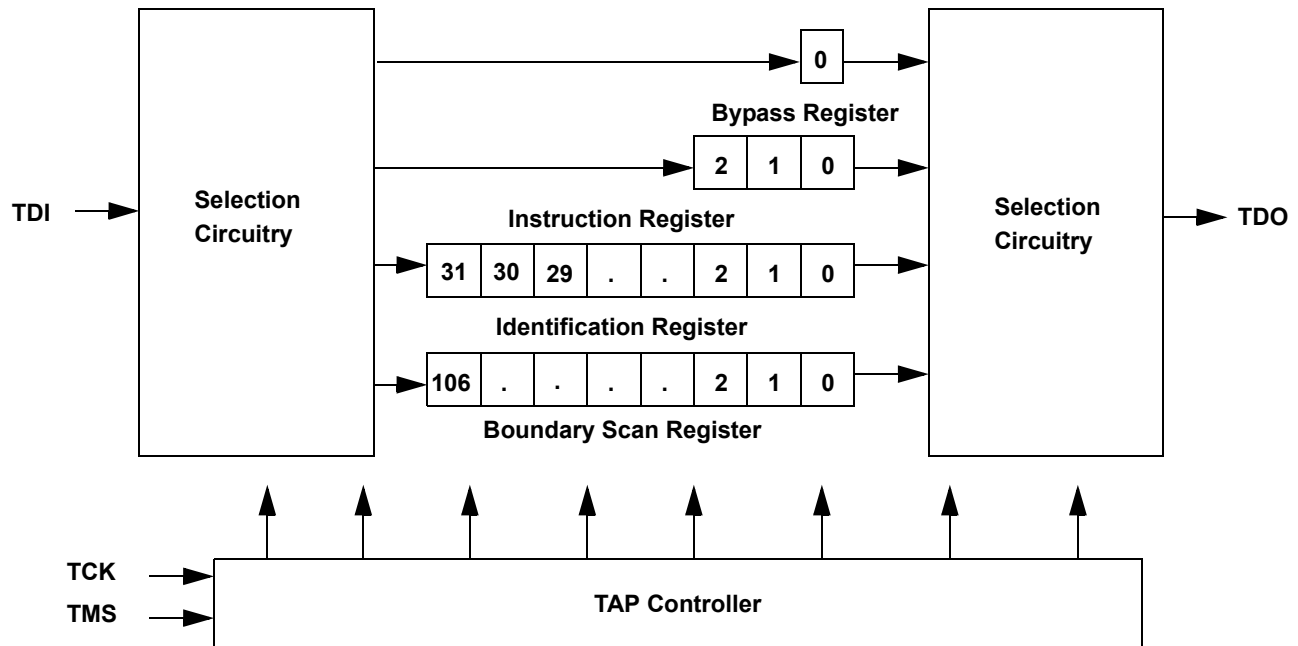

## TAP Electrical Characteristics

Over the Operating Range

Parameter <sup>[10, 11, 12]</sup>	Description	Test Conditions	Min	Max	Unit
V <sub>OH1</sub>	Output HIGH voltage	I <sub>OH</sub> = -2.0 mA	1.7	-	V
V <sub>OH2</sub>	Output HIGH voltage	I <sub>OH</sub> = -100 μA	2.1	-	V
V <sub>OL1</sub>	Output LOW voltage	I <sub>OL</sub> = 2.0 mA	-	0.7	V
V <sub>OL2</sub>	Output LOW voltage	I <sub>OL</sub> = 100 μA	-	0.2	V
V <sub>IH</sub>	Input HIGH voltage		1.7	V <sub>DD</sub> + 0.3	V
V <sub>IL</sub>	Input LOW voltage		-0.3	0.7	V
I <sub>X</sub>	Input and output load current	GND ≤ V <sub>I</sub> ≤ V <sub>DDQ</sub>	-5	5	μA

### Notes

10. These characteristics pertain to the TAP inputs (TMS, TCK, TDI and TDO). Parallel load levels are specified in the [Electrical Characteristics on page 17](#).
11. Overshoot: V<sub>IH(AC)</sub> < V<sub>DDQ</sub> + 0.85 V (Pulse width less than t<sub>CYC/2</sub>), Undershoot: V<sub>IL(AC)</sub> > -1.5 V (Pulse width less than t<sub>CYC/2</sub>).
12. All Voltage referenced to Ground.

## TAP AC Switching Characteristics

Over the Operating Range

Parameter <sup>[13, 14]</sup>	Description	Min	Max	Unit
$t_{TCYC}$	TCK clock cycle time	50	–	ns
$t_{TF}$	TCK clock frequency	–	20	MHz
$t_{TH}$	TCK clock HIGH	20	–	ns
$t_{TL}$	TCK clock LOW	20	–	ns
<b>Setup Times</b>				
$t_{TMSS}$	TMS setup to TCK clock rise	10	–	ns
$t_{TDIS}$	TDI setup to TCK clock rise	10	–	ns
$t_{CS}$	Capture setup to TCK rise	10	–	ns
<b>Hold Times</b>				
$t_{TMSh}$	TMS hold after TCK clock rise	10	–	ns
$t_{TDIH}$	TDI hold after clock rise	10	–	ns
$t_{CH}$	Capture hold after clock rise	10	–	ns
<b>Output Times</b>				
$t_{TDOV}$	TCK clock LOW to TDO valid	–	20	ns
$t_{TDOX}$	TCK clock LOW to TDO invalid	0	–	ns

### Notes

13.  $t_{CS}$  and  $t_{CH}$  refer to the setup and hold time requirements of latching data from the boundary scan register.  
 14. Test conditions are specified using the load in TAP AC test conditions.  $t_R/t_F = 1$  ns.

### TAP Timing and Test Conditions

Figure 3 shows the TAP timing and test conditions. [15]

**Figure 3. TAP Timing and Test Conditions**

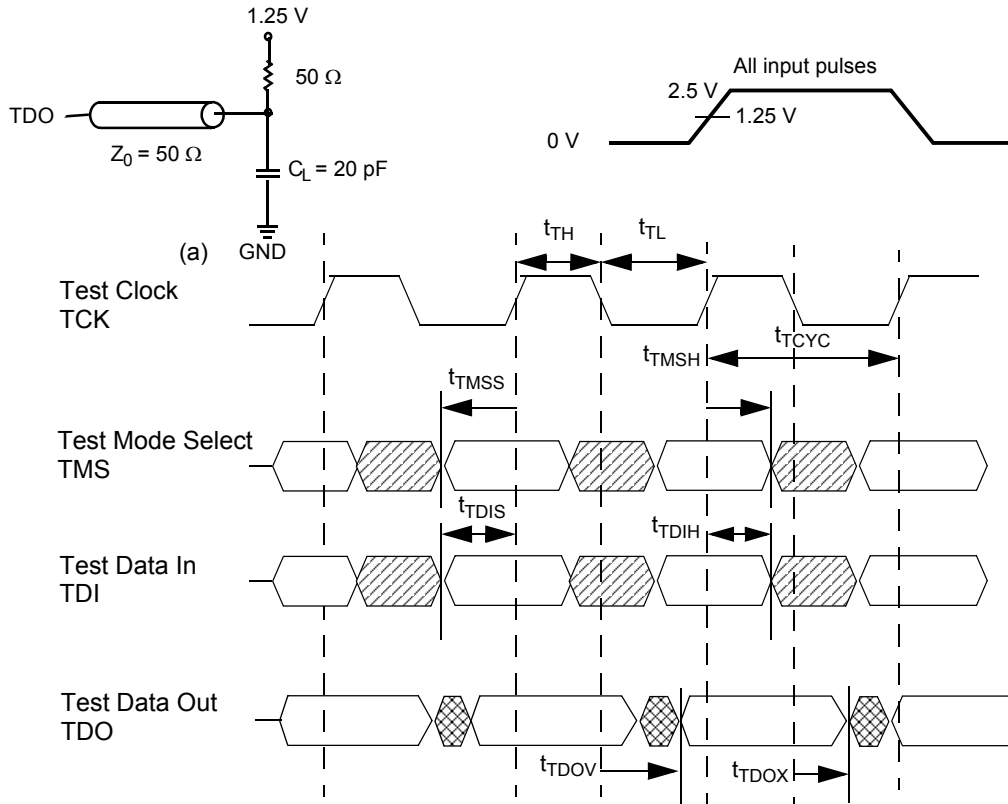

**Note**

15. Test conditions are specified using the load in TAP AC test conditions.  $t_R/t_F = 1$  ns.

## Identification Register Definitions

Instruction Field	Value	Description
	CY7C1303BV25	
Revision Number (31:29)	000	Version number.
Cypress Device ID (28:12)	01011010010010101	Defines the type of SRAM.
Cypress JEDEC ID (11:1)	00000110100	Allows unique identification of SRAM vendor.
ID Register Presence (0)	1	Indicate the presence of an ID register.

## Scan Register Sizes

Register Name	Bit Size
Instruction	3
Bypass	1
ID	32
Boundary Scan	107

## Instruction Codes

Instruction	Code	Description
EXTEST	000	Captures the I/O ring contents.
IDCODE	001	Loads the ID register with the vendor ID code and places the register between TDI and TDO. This operation does not affect SRAM operation.
SAMPLE Z	010	Captures the Input/Output contents. Places the boundary scan register between TDI and TDO. Forces all SRAM output drivers to a High Z state.
RESERVED	011	Do Not Use: This instruction is reserved for future use.
SAMPLE/PRELOAD	100	Captures the Input/Output ring contents. Places the boundary scan register between TDI and TDO. Does not affect the SRAM operation.
RESERVED	101	Do Not Use: This instruction is reserved for future use.
RESERVED	110	Do Not Use: This instruction is reserved for future use.
BYPASS	111	Places the bypass register between TDI and TDO. This operation does not affect SRAM operation.

**Boundary Scan Order**

Bit #	Bump ID
0	6R
1	6P
2	6N
3	7P
4	7N
5	7R
6	8R
7	8P
8	9R
9	11P
10	10P
11	10N
12	9P
13	10M
14	11N
15	9M
16	9N
17	11L
18	11M
19	9L
20	10L
21	11K
22	10K
23	9J
24	9K
25	10J
26	11J

Bit #	Bump ID
27	11H
28	10G
29	9G
30	11F
31	11G
32	9F
33	10F
34	11E
35	10E
36	10D
37	9E
38	10C
39	11D
40	9C
41	9D
42	11B
43	11C
44	9B
45	10B
46	11A
47	Internal
48	9A
49	8B
50	7C
51	6C
52	8A
53	7A

Bit #	Bump ID
54	7B
55	6B
56	6A
57	5B
58	5A
59	4A
60	5C
61	4B
62	3A
63	1H
64	1A
65	2B
66	3B
67	1C
68	1B
69	3D
70	3C
71	1D
72	2C
73	3E
74	2D
75	2E
76	1E
77	2F
78	3F
79	1G
80	1F

Bit #	Bump ID
81	3G
82	2G
83	1J
84	2J
85	3K
86	3J
87	2K
88	1K
89	2L
90	3L
91	1M
92	1L
93	3N
94	3M
95	1N
96	2M
97	3P
98	2N
99	2P
100	1P
101	3R
102	4R
103	4P
104	5P
105	5N
106	5R

## Maximum Ratings

Exceeding maximum ratings may shorten the useful life of the device. User guidelines are not tested.

Storage temperature ..... -65 °C to + 150 °C  
 Ambient temperature  
 with power applied ..... -55 °C to + 125 °C  
 Supply voltage on V<sub>DD</sub> relative to GND ..... -0.5 V to + 3.6 V  
 Supply voltage on V<sub>DDQ</sub> relative to GND ..... -0.5 V to + V<sub>DD</sub>  
 DC applied to outputs  
 in High Z state ..... -0.5 V to V<sub>DDQ</sub> + 0.5 V  
 DC input voltage<sup>[16]</sup> ..... -0.5 V to V<sub>DD</sub> + 0.5 V  
 Current into outputs (LOW) ..... 20 mA  
 Static discharge voltage  
 (per MIL-STD-883, Method 3015) ..... > 2001 V  
 Latch-up Current ..... > 200 mA

## Operating Range

Range	Ambient Temperature (T <sub>A</sub> )	V <sub>DD</sub> <sup>[17]</sup>	V <sub>DDQ</sub> <sup>[17]</sup>
Commercial	0 °C to + 70 °C	2.5 ± 0.1 V	1.4 V to 1.9 V

## Neutron Soft Error Immunity

Parameter	Description	Test Conditions	Typ	Max*	Unit
LSBU	Logical single-bit upsets	25 °C	320	368	FIT/Mb
LMBU	Logical multi-bit upsets	25 °C	0	0.01	FIT/Mb
SEL	Single event latch-up	85 °C	0	0.1	FIT/Dev

\* No LMBU or SEL events occurred during testing; this column represents a statistical  $\chi^2$ , 95% confidence limit calculation. For more details refer to Application Note, [Accelerated Neutron SER Testing and Calculation of Terrestrial Failure Rates – AN54908](#).

## Electrical Characteristics

Over the Operating Range

### DC Electrical Characteristics

Over the Operating Range

Parameter <sup>[18]</sup>	Description	Test Conditions	Min	Typ	Max	Unit
V <sub>DD</sub>	Power supply voltage		2.4	2.5	2.6	V
V <sub>DDQ</sub>	I/O supply voltage		1.4	1.5	1.9	V
V <sub>OH</sub>	Output HIGH voltage	Note 19	V <sub>DDQ</sub> /2 - 0.12	-	V <sub>DDQ</sub> /2 + 0.12	V
V <sub>OL</sub>	Output LOW voltage	Note 20	V <sub>DDQ</sub> /2 - 0.12	-	V <sub>DDQ</sub> /2 + 0.12	V
V <sub>OH(LOW)</sub>	Output HIGH voltage	I <sub>OH</sub> = -0.1 mA, nominal impedance	V <sub>DDQ</sub> - 0.2	-	V <sub>DDQ</sub>	V
V <sub>OL(LOW)</sub>	Output LOW voltage	I <sub>OL</sub> = 0.1 mA, nominal impedance	V <sub>SS</sub>	-	0.2	V
V <sub>IH</sub>	Input HIGH voltage <sup>[16]</sup>		V <sub>REF</sub> + 0.1	-	V <sub>DDQ</sub> + 0.3	V
V <sub>IL</sub>	Input LOW voltage <sup>[16, 21]</sup>		-0.3	-	V <sub>REF</sub> - 0.1	V
V <sub>REF</sub>	Input Reference voltage <sup>[22]</sup>	Typical value = 0.75 V	0.68	0.75	0.95	V
I <sub>X</sub>	Input Leakage current	GND ≤ V <sub>I</sub> ≤ V <sub>DDQ</sub>	-5	-	5	μA
I <sub>OZ</sub>	Output Leakage current	GND ≤ V <sub>I</sub> ≤ V <sub>DDQ</sub> , output disabled	-5	-	5	μA

### Notes

16. Overshoot: V<sub>IH(AC)</sub> < V<sub>DDQ</sub> + 0.85 V (Pulse width less than t<sub>CYC/2</sub>), Undershoot: V<sub>IL(AC)</sub> > -1.5 V (Pulse width less than t<sub>CYC/2</sub>).
17. Power-up: Assumes a linear ramp from 0 V to V<sub>DD(min.)</sub> within 200 ms. During this time V<sub>IH</sub> < V<sub>DD</sub> and V<sub>DDQ</sub> ≤ V<sub>DD</sub>.
18. All Voltage referenced to Ground.
19. Output are impedance controlled. I<sub>OH</sub> = -V<sub>DDQ</sub>/2)/(RQ/5) for values of 175 Ω ≤ RQ ≤ 350 Ω.
20. Output are impedance controlled. I<sub>OL</sub> = (V<sub>DDQ</sub>/2)/(RQ/5) for values of 175 Ω ≤ RQ ≤ 350 Ω.
21. This spec is for all inputs except C and C̄ Clock. For C and C̄ Clock, V<sub>IL(Max.)</sub> = V<sub>REF</sub> - 0.2 V.
22. V<sub>REF(Min.)</sub> = 0.68 V or 0.46 V<sub>DDQ</sub>, whichever is larger, V<sub>REF(Max.)</sub> = 0.95 V or 0.54 V<sub>DDQ</sub>, whichever is smaller.

### Electrical Characteristics (continued)

Over the Operating Range

#### DC Electrical Characteristics (continued)

Over the Operating Range

Parameter <sup>[18]</sup>	Description	Test Conditions	Min	Typ	Max	Unit
$I_{DD}$	$V_{DD}$ operating supply	$V_{DD} = \text{Max.}$ , $I_{OUT} = 0 \text{ mA}$ , $f = f_{MAX} = 1/t_{CYC}$	–	–	500	mA
$I_{SB1}$	Automatic power-down current	Max. $V_{DD}$ , both ports deselected, $V_{IN} \geq V_{IH}$ or $V_{IN} \leq V_{IL}$ , $f = f_{MAX} = 1/t_{CYC}$ , inputs static	–	–	240	mA

#### AC Electrical Characteristics

Over the Operating Range

Parameter	Description	Test Conditions	Min	Typ	Max	Unit
$V_{IH}$	Input HIGH voltage		$V_{REF} + 0.2$	–	–	V
$V_{IL}$	Input LOW voltage		–	–	$V_{REF} - 0.2$	V

#### Thermal Resistance

Parameter <sup>[23]</sup>	Description	Test Conditions	165-ball FBGA Package	Unit
$\Theta_{JA}$	Thermal resistance (junction to ambient)	Test conditions follow standard test methods and procedures for measuring thermal impedance, per EIA/JESD51.	16.7	$^{\circ}\text{C}/\text{W}$
$\Theta_{JC}$	Thermal resistance (junction to case)		6.5	$^{\circ}\text{C}/\text{W}$

#### Capacitance

Parameter <sup>[23]</sup>	Description	Test Conditions	Max	Unit
$C_{IN}$	Input capacitance	$T_A = 25^{\circ}\text{C}$ , $f = 1 \text{ MHz}$ , $V_{DD} = 2.5 \text{ V}$ , $V_{DDQ} = 1.5 \text{ V}$	5	pF
$C_{CLK}$	Clock input capacitance		6	pF
$C_O$	Output capacitance		7	pF

#### AC Test Loads and Waveforms

Figure 4. AC Test Loads and Waveforms

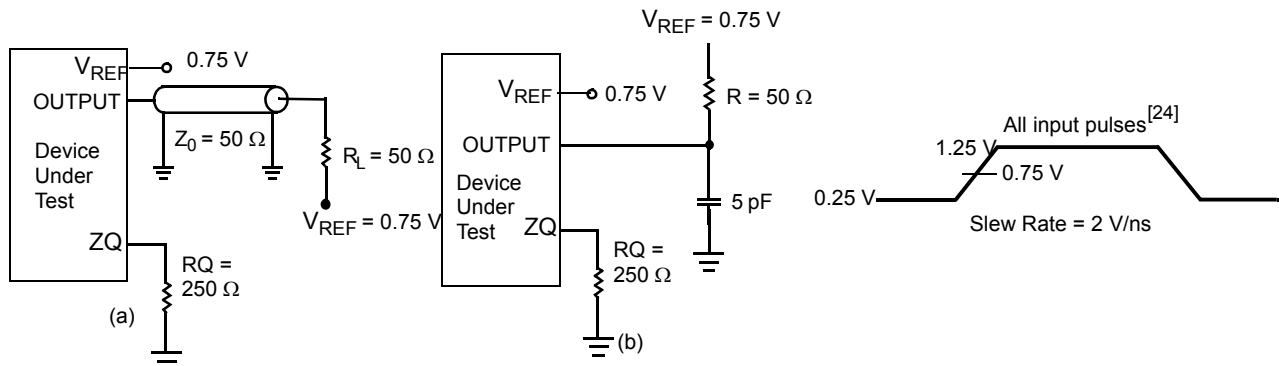

**Notes**

23. Tested initially and after any design or process change that may affect these parameters.

24. Unless otherwise noted, test conditions assume signal transition time of 2 V/ns, timing reference levels of 0.75 V,  $V_{REF} = 0.75 \text{ V}$ ,  $R_Q = 250 \Omega$ ,  $V_{DDQ} = 1.5 \text{ V}$ , input pulse levels of 0.25 V to 1.25 V, and output loading of the specified  $I_{OL}/I_{OH}$  and load capacitance shown in (a) of Figure 4.

## Switching Characteristics

Over the Operating Range

Parameter <sup>[25]</sup>		Description	167 MHz		Unit
Cypress Parameter	Consortium Parameter		Min	Max	
$t_{Power}^{[26]}$		$V_{CC}$ (typical) to the first access read or write	10	–	$\mu s$
<b>Cycle Time</b>					
$t_{CYC}$	$t_{KHKH}$	K clock and C clock cycle time	6.0	–	ns
$t_{KH}$	$t_{KHKL}$	Input clock ( $K/\bar{K}$ and $C/\bar{C}$ ) HIGH	2.4	–	ns
$t_{KL}$	$t_{KLKH}$	Input clock ( $K/\bar{K}$ and $C/\bar{C}$ ) LOW	2.4	–	ns
$t_{KH\bar{K}H}$	$t_{KH\bar{K}H}$	$K/\bar{K}$ clock rise to $\bar{K}/K$ clock rise and $C/\bar{C}$ to $C/\bar{C}$ rise (rising edge to rising edge)	2.7	3.3	ns
$t_{KHCH}$	$t_{KHCH}$	$K/\bar{K}$ clock rise to $C/\bar{C}$ Clock rise (rising edge to rising edge)	0.0	2.0	ns
<b>Setup Times</b>					
$t_{SA}$	$t_{SA}$	Address setup to clock (K and $\bar{K}$ ) Rise	0.7	–	ns
$t_{SC}$	$t_{SC}$	Control setup to clock (K and $\bar{K}$ ) Rise ( $\overline{RPS}$ , $\overline{WPS}$ , $\overline{BWS}_0$ , $\overline{BWS}_1$ )	0.7	–	ns
$t_{SD}$	$t_{SD}$	$D_{[x:0]}$ setup to clock (K and $\bar{K}$ ) Rise	0.7	–	ns
<b>Hold Times</b>					
$t_{HA}$	$t_{HA}$	Address hold after clock (K and $\bar{K}$ ) Rise	0.7	–	ns
$t_{HC}$	$t_{HC}$	Control signals hold after clock (K and $\bar{K}$ ) Rise ( $\overline{RPS}$ , $\overline{WPS}$ , $\overline{BWS}_0$ , $\overline{BWS}_1$ )	0.7	–	ns
$t_{HD}$	$t_{HD}$	$D_{[x:0]}$ hold after clock (K and $\bar{K}$ ) Rise	0.7	–	ns
<b>Output Times</b>					
$t_{CO}$	$t_{CHQV}$	$C/\bar{C}$ clock rise (or $K/\bar{K}$ in single clock mode) to data valid	–	2.5	ns
$t_{DOH}$	$t_{CHQX}$	Data output hold after output $C/\bar{C}$ clock rise (active to active)	1.2	–	ns
$t_{CHZ}$	$t_{CHZ}$	Clock (C and $\bar{C}$ ) rise to high Z (active to high Z) <sup>[27, 28]</sup>	–	2.5	ns
$t_{CLZ}$	$t_{CLZ}$	Clock (C and $\bar{C}$ ) rise to low Z <sup>[27, 28]</sup>	1.2	–	ns

### Notes

25. Unless otherwise noted, test conditions assume signal transition time of 2 V/ns, timing reference levels of 0.75 V,  $V_{REF} = 0.75$  V,  $R_Q = 250 \Omega$ ,  $V_{DDQ} = 1.5$  V, input pulse levels of 0.25 V to 1.25 V, and output loading of the specified  $I_{OL}/I_{OH}$  and load capacitance shown in (a) of [Figure 4 on page 18](#).

26. This part has a voltage regulator that steps down the voltage internally;  $t_{Power}$  is the time power needs to be supplied above  $V_{DD}$  minimum initially before a read or write operation can be initiated.

27. At any given voltage and temperature  $t_{CHZ}$  is less than  $t_{CLZ}$  and,  $t_{CHZ}$  less than  $t_{CO}$ .

28.  $t_{CHZ}$ ,  $t_{CLZ}$ , are specified with a load capacitance of 5 pF as in part (b) of [Figure 4 on page 18](#). Transition is measured  $\pm 100$  mV from steady-state voltage.

## Switching Waveforms

Figure 5. Switching Waveforms [29, 30, 31]

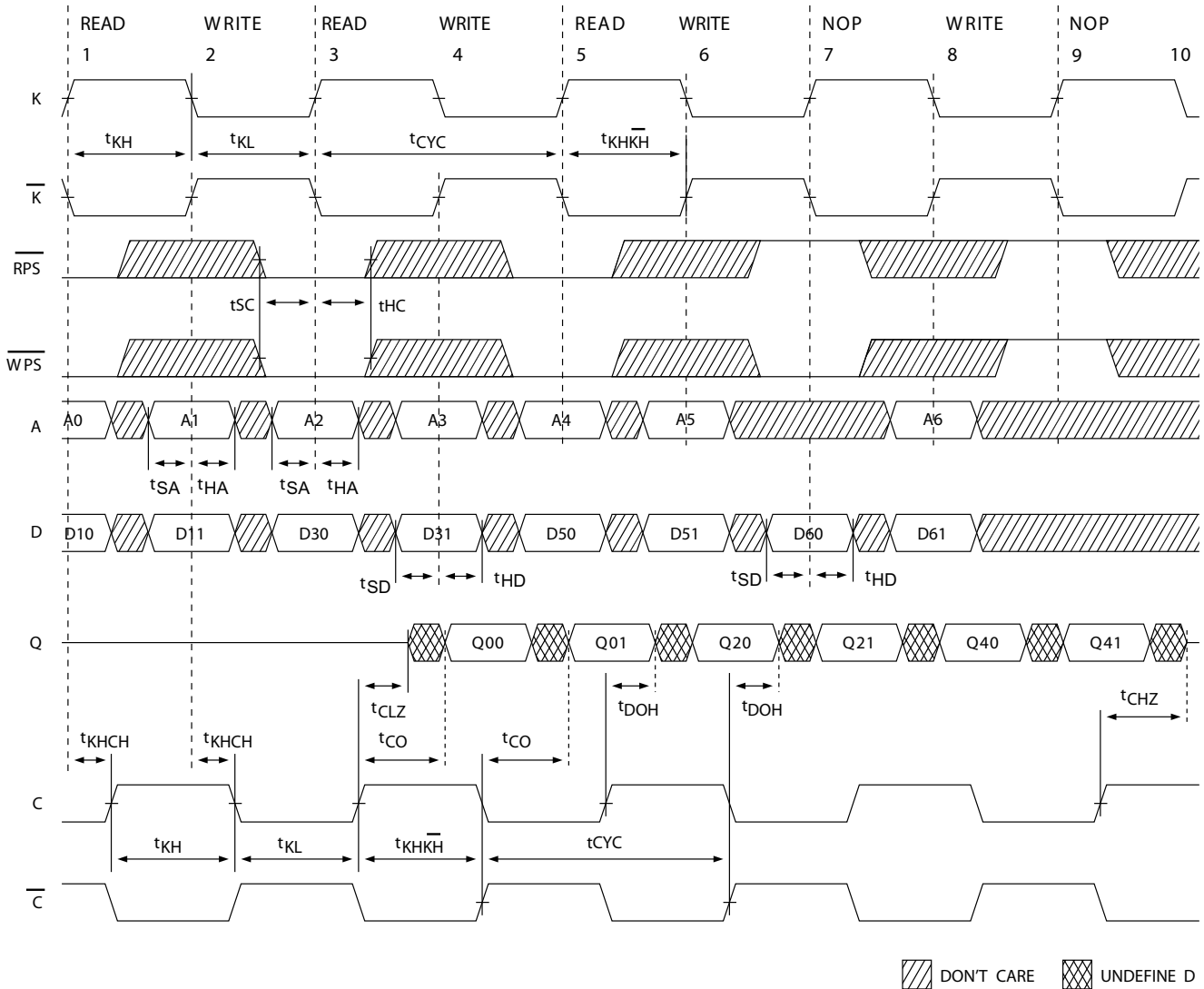

**Notes**

29. Q00 refers to output from address A0. Q01 refers to output from the next internal burst address following A0, i.e., A0 + 1.

30. Outputs are disabled (High Z) one clock cycle after a NOP.

31. In this example, if address A2 = A1 then data Q20 = D10 and Q21 = D11. Write data is forwarded immediately as read results. This note applies to the whole diagram.

### Ordering Information

The table below contains only the parts that are currently available. If you don't see what you are looking for, please contact your local sales representative. For more information, visit the Cypress website at [www.cypress.com](http://www.cypress.com) and refer to the product summary page at <http://www.cypress.com/products>

Cypress maintains a worldwide network of offices, solution centers, manufacturer's representatives and distributors. To find the office closest to you, visit us at <http://www.cypress.com/go/datasheet/offices>.

Speed (MHz)	Ordering Code	Package Diagram	Package Type	Operating Range
167	CY7C1303BV25-167BZC	51-85180	165-ball FBGA (13 × 15 × 1.4 mm)	Commercial

### Ordering Code Definitions

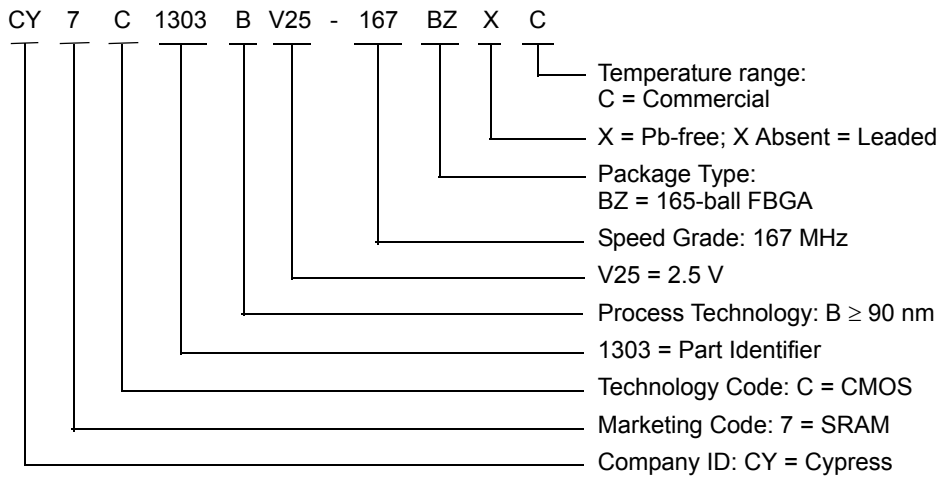

### Package Diagram

Figure 6. 165-ball FBGA (13 × 15 × 1.4 mm) BB165D/BW165D (0.5 Ball Diameter) Package Outline, 51-85180

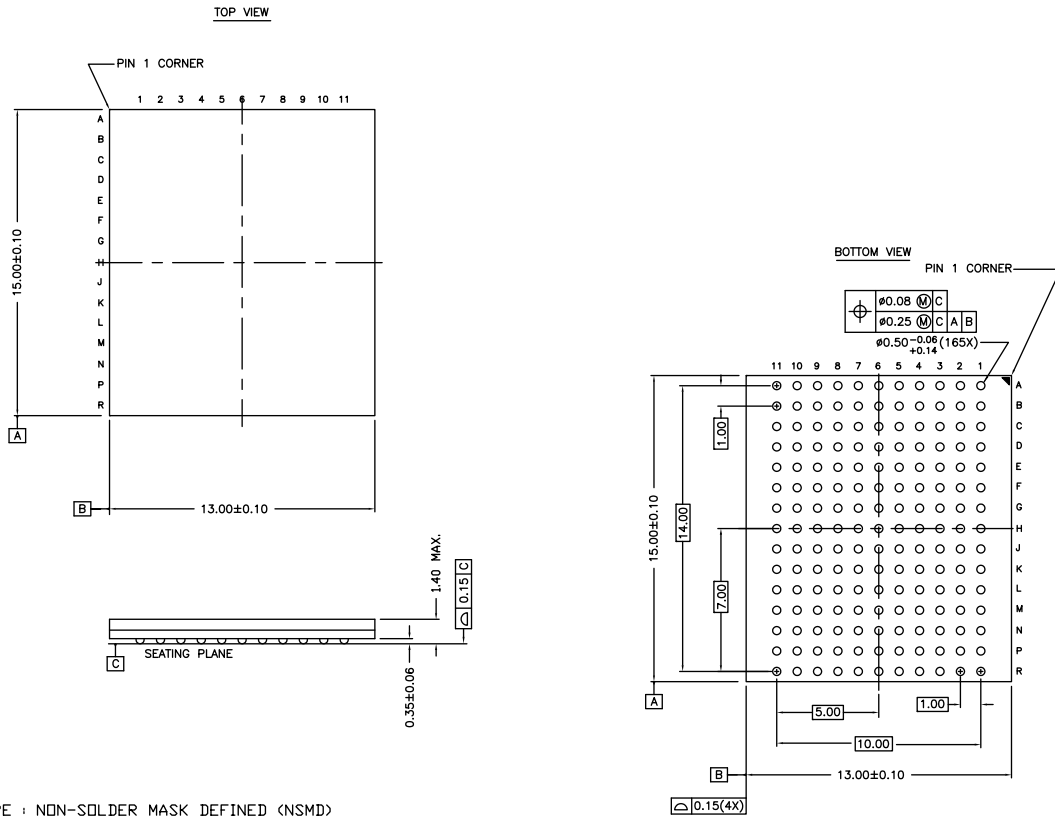

NOTES :  
 SOLDER PAD TYPE : NON-SOLDER MASK DEFINED (NSMD)  
 JEDEC REFERENCE : MO-216 / ISSUE E  
 PACKAGE CODE : B80AC/BW0AC  
 PACKAGE WEIGHT : SEE CYPRESS PACKAGE MATERIAL DECLARATION  
 DATASHEET (PMDD) POSTED ON THE CYPRESS WEB.

51-85180 \*G

## Acronyms

Acronym	Description
DDR	Double Data Rate
FBGA	Fine-Pitch Ball Grid Array
HSTL	High-Speed Transceiver Logic
I/O	Input/Output
JEDEC	Joint Electron Device Engineering Council
JTAG	Joint Test Action Group
LMBU	Logical Multi-Bit Upsets
LSB	Least Significant Bit
LSBU	Logical Single-Bit Upsets
MSB	Most Significant Bit
PLL	Phase-Locked Loop
QDR	Quad Data Rate
SEL	Single Event Latch-up
SRAM	Static Random Access Memory
TAP	Test Access Port
TCK	Test Clock
TDI	Test Data In
TDO	Test Data Out
TMS	Test Mode Select

## Document Conventions

### Units of Measure

Symbol	Unit of Measure
°C	degree Celsius
kΩ	kilohm
MHz	megahertz
μA	microampere
μs	microsecond
mA	milliampere
mV	millivolt
mm	millimeter
ms	millisecond
ns	nanosecond
Ω	ohm
%	percent
pF	picofarad
ps	picosecond
V	volt
W	watt

**Document History Page**

Document Title: CY7C1303BV25, 18-Mbit Burst of Two-Pipelined SRAM with QDR® Architecture				
Document Number: 38-05627				
Rev.	ECN	Orig. of Change	Submission Date	Description of Change
**	253010	SYT	08/13/04	New data sheet.
*A	436864	NXR	See ECN	<p>Changed status from Preliminary to Final.</p> <p>Updated <a href="#">Features</a> (Changed C/C description).</p> <p>Updated <a href="#">Selection Guide</a> (Removed 133 MHz and 100 MHz from product offering).</p> <p>Updated <a href="#">Pin Definitions</a> (Updated C/C description, updated ZQ description (Alternately, this pin can be connected directly to V<sub>DDQ</sub>, which enables the minimum impedance mode.)).</p> <p>Updated <a href="#">TAP AC Switching Characteristics</a> (Changed minimum value of t<sub>TCYC</sub> parameter from 100 ns to 50 ns, changed maximum value of t<sub>TF</sub> parameter from 10 MHz to 20 MHz, changed minimum value of t<sub>TH</sub> and t<sub>TL</sub> parameters from 40 ns to 20 ns).</p> <p>Updated <a href="#">Maximum Ratings</a> (Included Maximum Ratings for Supply Voltage on V<sub>DDQ</sub> Relative to GND, changed the Maximum Ratings for DC Input Voltage from V<sub>DDQ</sub> to V<sub>DD</sub>).</p> <p>Updated <a href="#">Operating Range</a> (Updated Note 17 (Modified test condition from V<sub>DDQ</sub> &lt; V<sub>DD</sub> to V<sub>DDQ</sub> ≤ V<sub>DD</sub>), included the Industrial Operating Range).</p> <p>Updated <a href="#">Electrical Characteristics</a> (Changed description of I<sub>X</sub> parameter from Input Load current to Input Leakage Current, removed 133 MHz and 100 MHz from product offering).</p> <p>Updated <a href="#">Ordering Information</a> (Updated table and replaced Package Name Column with Package Diagram).</p>
*B	2755901	VKN	08/25/09	<p>Added <a href="#">Neutron Soft Error Immunity</a>.</p> <p>Updated <a href="#">Ordering Information</a> (Updated table by including parts that are available, and modified the disclaimer for the Ordering information).</p> <p>Updated <a href="#">Package Diagram</a>.</p>
*C	2998771	NJY	08/02/10	<p>Updated <a href="#">Package Diagram</a>.</p> <p>Updated to new template.</p>
*D	3310077	OSN	07/12/2011	<p>Added <a href="#">Units of Measure</a>.</p> <p>Updated to new template.</p>
*E	3534369	PRIT	02/24/2012	<p>Updated <a href="#">Configurations</a> (Removed CY7C1306BV25 related information).</p> <p>Updated <a href="#">Functional Description</a> (Removed CY7C1306BV25 related information).</p> <p>Updated <a href="#">Selection Guide</a> (Removed CY7C1306BV25 related information).</p> <p>Removed Logic Block Diagram – CY7C1306BV25.</p> <p>Updated <a href="#">Pin Configuration</a> (Removed CY7C1306BV25 related information).</p> <p>Updated <a href="#">Pin Definitions</a> (Removed CY7C1306BV25 related information).</p> <p>Updated <a href="#">Functional Overview</a> (Removed CY7C1306BV25 related information).</p> <p>Updated <a href="#">Truth Table</a> (Removed CY7C1306BV25 related information).</p> <p>Updated <a href="#">Write Cycle Descriptions</a> (Removed CY7C1306BV25 related information).</p> <p>Updated <a href="#">Identification Register Definitions</a> (Removed CY7C1306BV25 related information).</p> <p>Updated <a href="#">Operating Range</a> (Removed Industrial Operating Range).</p> <p>Updated <a href="#">Package Diagram</a>.</p>
*F	3690005	PRIT	07/24/2012	<p>No technical updates.</p> <p>Completing Sunset Review.</p>

**Document History Page (continued)**

Document Title: CY7C1303BV25, 18-Mbit Burst of Two-Pipelined SRAM with QDR <sup>®</sup> Architecture				
Document Number: 38-05627				
Rev.	ECN	Orig. of Change	Submission Date	Description of Change
*G	4064320	PRIT	07/16/2013	Updated <a href="#">Package Diagram</a> : spec 51-85180 – Changed revision from *E to *F. Updated to new template. Completing Sunset Review.
*H	4567085	PRIT	11/11/2014	Updated <a href="#">Functional Description</a> : Added “For a complete list of related documentation, click <a href="#">here</a> .” at the end.
*I	5374246	PRIT	07/26/2016	Updated <a href="#">Package Diagram</a> : spec 51-85180 – Changed revision from *F to *G. Updated to new template. Completing Sunset Review.
*J	6012218	AESATMP9	01/03/2018	Updated logo and copyright.

## Sales, Solutions, and Legal Information

### Worldwide Sales and Design Support

Cypress maintains a worldwide network of offices, solution centers, manufacturer's representatives, and distributors. To find the office closest to you, visit us at [Cypress Locations](#).

#### Products

Arm <sup>®</sup> Cortex <sup>®</sup> Microcontrollers	<a href="http://cypress.com/arm">cypress.com/arm</a>
Automotive	<a href="http://cypress.com/automotive">cypress.com/automotive</a>
Clocks & Buffers	<a href="http://cypress.com/clocks">cypress.com/clocks</a>
Interface	<a href="http://cypress.com/interface">cypress.com/interface</a>
Internet of Things	<a href="http://cypress.com/iot">cypress.com/iot</a>
Memory	<a href="http://cypress.com/memory">cypress.com/memory</a>
Microcontrollers	<a href="http://cypress.com/mcu">cypress.com/mcu</a>
PSoC	<a href="http://cypress.com/psoc">cypress.com/psoc</a>
Power Management ICs	<a href="http://cypress.com/pmic">cypress.com/pmic</a>
Touch Sensing	<a href="http://cypress.com/touch">cypress.com/touch</a>
USB Controllers	<a href="http://cypress.com/usb">cypress.com/usb</a>
Wireless Connectivity	<a href="http://cypress.com/wireless">cypress.com/wireless</a>

#### PSoC<sup>®</sup> Solutions

[PSoC 1](#) | [PSoC 3](#) | [PSoC 4](#) | [PSoC 5LP](#) | [PSoC 6 MCU](#)

#### Cypress Developer Community

[Community](#) | [Projects](#) | [Video](#) | [Blogs](#) | [Training](#) | [Components](#)

#### Technical Support

[cypress.com/support](http://cypress.com/support)



© Cypress Semiconductor Corporation, 2004-2018. This document is the property of Cypress Semiconductor Corporation and its subsidiaries, including Spansion LLC ("Cypress"). This document, including any software or firmware included or referenced in this document ("Software"), is owned by Cypress under the intellectual property laws and treaties of the United States and other countries worldwide. Cypress reserves all rights under such laws and treaties and does not, except as specifically stated in this paragraph, grant any license under its patents, copyrights, trademarks, or other intellectual property rights. If the Software is not accompanied by a license agreement and you do not otherwise have a written agreement with Cypress governing the use of the Software, then Cypress hereby grants you a personal, non-exclusive, nontransferable license (without the right to sublicense) (1) under its copyright rights in the Software (a) for Software provided in source code form, to modify and reproduce the Software solely for use with Cypress hardware products, only internally within your organization, and (b) to distribute the Software in binary code form externally to end users (either directly or indirectly through resellers and distributors), solely for use on Cypress hardware product units, and (2) under those claims of Cypress's patents that are infringed by the Software (as provided by Cypress, unmodified) to make, use, distribute, and import the Software solely for use with Cypress hardware products. Any other use, reproduction, modification, translation, or compilation of the Software is prohibited.

TO THE EXTENT PERMITTED BY APPLICABLE LAW, CYPRESS MAKES NO WARRANTY OF ANY KIND, EXPRESS OR IMPLIED, WITH REGARD TO THIS DOCUMENT OR ANY SOFTWARE OR ACCOMPANYING HARDWARE, INCLUDING, BUT NOT LIMITED TO, THE IMPLIED WARRANTIES OF MERCHANTABILITY AND FITNESS FOR A PARTICULAR PURPOSE. No computing device can be absolutely secure. Therefore, despite security measures implemented in Cypress hardware or software products, Cypress does not assume any liability arising out of any security breach, such as unauthorized access to or use of a Cypress product. In addition, the products described in these materials may contain design defects or errors known as errata which may cause the product to deviate from published specifications. To the extent permitted by applicable law, Cypress reserves the right to make changes to this document without further notice. Cypress does not assume any liability arising out of the application or use of any product or circuit described in this document. Any information provided in this document, including any sample design information or programming code, is provided only for reference purposes. It is the responsibility of the user of this document to properly design, program, and test the functionality and safety of any application made of this information and any resulting product. Cypress products are not designed, intended, or authorized for use as critical components in systems designed or intended for the operation of weapons, weapons systems, nuclear installations, life-support devices or systems, other medical devices or systems (including resuscitation equipment and surgical implants), pollution control or hazardous substances management, or other uses where the failure of the device or system could cause personal injury, death, or property damage ("Unintended Uses"). A critical component is any component of a device or system whose failure to perform can be reasonably expected to cause the failure of the device or system, or to affect its safety or effectiveness. Cypress is not liable, in whole or in part, and you shall and hereby do release Cypress from any claim, damage, or other liability arising from or related to all Unintended Uses of Cypress products. You shall indemnify and hold Cypress harmless from and against all claims, costs, damages, and other liabilities, including claims for personal injury or death, arising from or related to any Unintended Uses of Cypress products.

Cypress, the Cypress logo, Spansion, the Spansion logo, and combinations thereof, WICED, PSoC, CapSense, EZ-USB, F-RAM, and Traveo are trademarks or registered trademarks of Cypress in the United States and other countries. For a more complete list of Cypress trademarks, visit [cypress.com](http://cypress.com). Other names and brands may be claimed as property of their respective owners.

## Looking for pricing, stock, or lifecycle information?

Click below to explore more details on WIN SOURCE:

-  [View CY7C1303BV25-167BZC on WIN SOURCE](#)
-  [Cypress Semiconductor Corp Information](#)

## Optimize Your Supply Chain with WIN SOURCE Solutions

-  Global Sourcing Solution
-  Obsolete Management
-  Cost Control Management
-  Shortage Management
-  Alternative Solution
-  Excess Inventory Management