



**THE DATASHEET OF  
CY7C1049B-20VC**





512K x 8 Static RAM

Features

- High speed
  - $t_{AA} = 12 \text{ ns}$
- Low active power
  - 1320 mW (max.)
- Low CMOS standby power (Commercial L version)
  - 2.75 mW (max.)
- 2.0V Data Retention (400  $\mu\text{W}$  at 2.0V retention)
- Automatic power-down when deselected
- TTL-compatible inputs and outputs
- Easy memory expansion with  $\overline{\text{CE}}$  and  $\overline{\text{OE}}$  features

Functional Description<sup>[1]</sup>

The CY7C1049B is a high-performance CMOS static RAM organized as 524,288 words by 8 bits. Easy memory expansion

is provided by an active LOW Chip Enable ( $\overline{\text{CE}}$ ), an active LOW Output Enable ( $\overline{\text{OE}}$ ), and three-state drivers. Writing to the device is accomplished by taking Chip Enable ( $\overline{\text{CE}}$ ) and Write Enable ( $\overline{\text{WE}}$ ) inputs LOW. Data on the eight I/O pins ( $\text{I/O}_0$  through  $\text{I/O}_7$ ) is then written into the location specified on the address pins ( $\text{A}_0$  through  $\text{A}_{18}$ ).

Reading from the device is accomplished by taking Chip Enable ( $\overline{\text{CE}}$ ) and Output Enable ( $\overline{\text{OE}}$ ) LOW while forcing Write Enable ( $\overline{\text{WE}}$ ) HIGH. Under these conditions, the contents of the memory location specified by the address pins will appear on the I/O pins.

The eight input/output pins ( $\text{I/O}_0$  through  $\text{I/O}_7$ ) are placed in a high-impedance state when the device is deselected ( $\overline{\text{CE}}$  HIGH), the outputs are disabled ( $\overline{\text{OE}}$  HIGH), or during a write operation ( $\overline{\text{CE}}$  LOW, and  $\overline{\text{WE}}$  LOW).

The CY7C1049B is available in a standard 400-mil-wide 36-pin SOJ package with center power and ground (revolutionary) pinout.

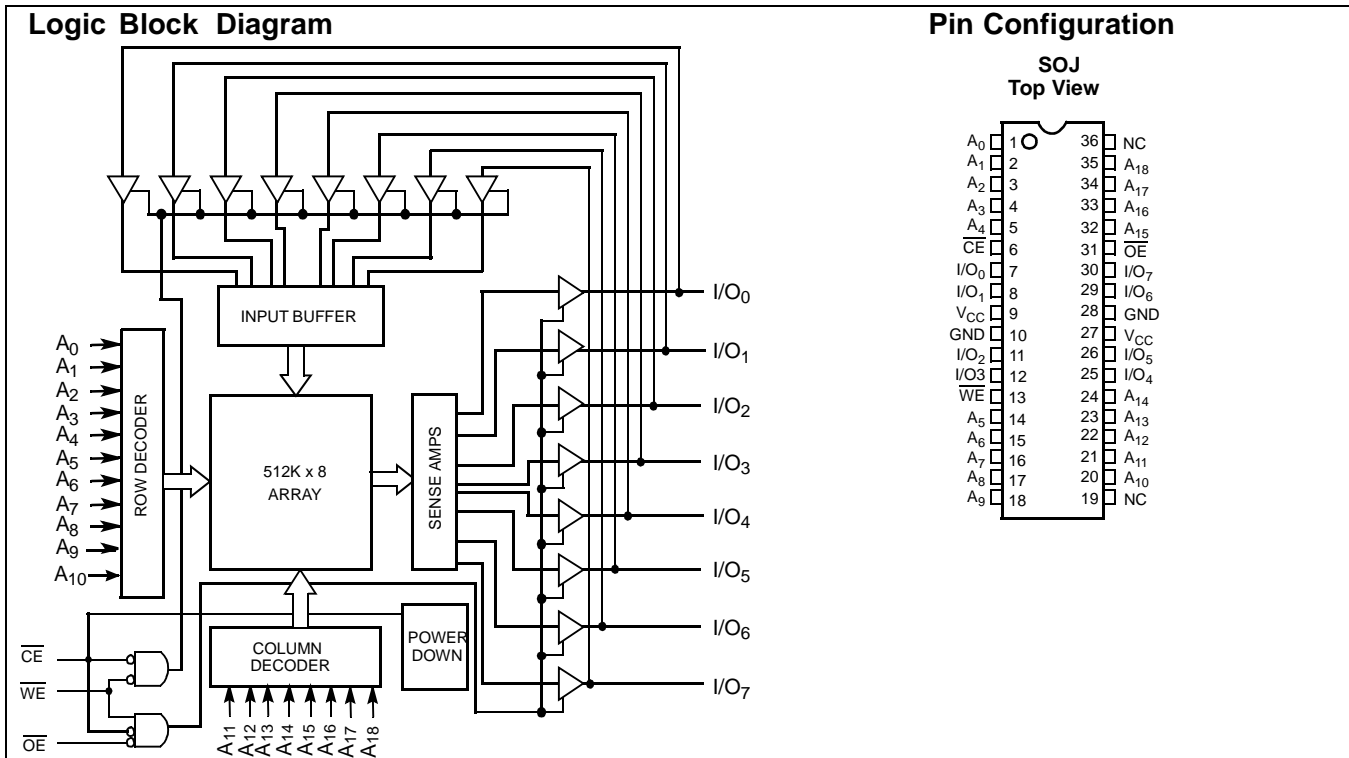

Selection Guide

	7C1049B-12	7C1049B-15	7C1049B-17	7C1049B-20	7C1049B-25
Maximum Access Time (ns)	12	15	17	20	25
Maximum Operating Current (mA)	240	220	195	185	180
Maximum CMOS Standby Current (mA)	Com'l	8	8	8	8
	Com'l/Ind'l   L	-	-	0.5	0.5
	Ind'l	-	-	-	9

Note:

1. For guidelines on SRAM system design, please refer to the 'System Design Guidelines' Cypress application note, available on the internet at [www.cypress.com](http://www.cypress.com).

### Maximum Ratings

(Above which the useful life may be impaired. For user guidelines, not tested.)

Storage Temperature ..... -65°C to +150°C  
 Ambient Temperature with Power Applied..... -55°C to +125°C  
 Supply Voltage on  $V_{CC}$  to Relative GND<sup>[2]</sup> .... -0.5V to +7.0V  
 DC Voltage Applied to Outputs in High Z State<sup>[2]</sup> ..... -0.5V to  $V_{CC} + 0.5V$   
 DC Input Voltage<sup>[2]</sup>..... -0.5V to  $V_{CC} + 0.5V$

Current into Outputs (LOW) ..... 20 mA  
 Static Discharge Voltage..... >2001V (per MIL-STD-883, Method 3015)  
 Latch-Up Current..... >200 mA

### Operating Range

Range	Ambient Temperature	$V_{CC}$
Commercial	0°C to +70°C	4.5V–5.5V
Industrial	-40°C to +85°C	

### Electrical Characteristics Over the Operating Range

Parameter	Description	Test Conditions	7C1049B-12		7C1049B-15		7C1049B-17		Unit		
			Min.	Max.	Min.	Max.	Min.	Max.			
$V_{OH}$	Output HIGH Voltage	$V_{CC} = \text{Min.}, I_{OH} = -4.0 \text{ mA}$	2.4		2.4		2.4		V		
$V_{OL}$	Output LOW Voltage	$V_{CC} = \text{Min.}, I_{OL} = 8.0 \text{ mA}$		0.4		0.4		0.4	V		
$V_{IH}$	Input HIGH Voltage		2.2	$V_{CC} + 0.3$	2.2	$V_{CC} + 0.3$	2.2	$V_{CC} + 0.3$	V		
$V_{IL}$	Input LOW Voltage <sup>[2]</sup>		-0.3	0.8	-0.3	0.8	-0.3	0.3	V		
$I_{IX}$	Input Load Current	$GND \leq V_I \leq V_{CC}$	-1	+1	-1	+1	-1	+1	$\mu\text{A}$		
$I_{OZ}$	Output Leakage Current	$GND \leq V_{OUT} \leq V_{CC}$ , Output Disabled	-1	+1	-1	+1	-1	+1	$\mu\text{A}$		
$I_{CC}$	$V_{CC}$ Operating Supply Current	$V_{CC} = \text{Max.}$ $f = f_{MAX} = 1/t_{RC}$		240		220		195	mA		
$I_{SB1}$	Automatic CE Power-Down Current —TTL Inputs	Max. $V_{CC}$ , $\overline{CE} \geq V_{IH}$ $V_{IN} \geq V_{IH}$ or $V_{IN} \leq V_{IL}$ , $f = f_{MAX}$		40		40		40	mA		
$I_{SB2}$	Automatic CE Power-Down Current —CMOS Inputs	Max. $V_{CC}$ , $\overline{CE} \geq V_{CC} - 0.3V$ , $V_{IN} \geq V_{CC} - 0.3V$ , or $V_{IN} \leq 0.3V$ , $f = 0$	Com'l			8		8		mA	
			Com'l	L		-		-		0.5	mA
			Ind'l			-		-		8	mA
			Ind'l	L		-		-		0.5	mA

**Note:**

2. Minimum voltage is -2.0V for pulse durations of less than 20 ns.

**Electrical Characteristics** Over the Operating Range (continued)

Parameter	Description	Test Conditions	7C1049B-20		7C1049B-25		Unit		
			Min.	Max.	Min.	Max.			
$V_{OH}$	Output HIGH Voltage	$V_{CC} = \text{Min.}, I_{OH} = -4.0 \text{ mA}$	2.4		2.4		V		
$V_{OL}$	Output LOW Voltage	$V_{CC} = \text{Min.}, I_{OL} = 8.0 \text{ mA}$		0.4		0.4	V		
$V_{IH}$	Input HIGH Voltage		2.2	$V_{CC} + 0.3$	2.2	$V_{CC} + 0.3$	V		
$V_{IL}$	Input LOW Voltage <sup>[2]</sup>		-0.3	0.8	-0.3	0.8	V		
$I_{IX}$	Input Load Current	$GND \leq V_I \leq V_{CC}$	-1	+1	-1	+1	$\mu\text{A}$		
$I_{OZ}$	Output Leakage Current	$GND \leq V_{OUT} \leq V_{CC}$ , Output Disabled	-1	+1	-1	+1	$\mu\text{A}$		
$I_{CC}$	$V_{CC}$ Operating Supply Current	$V_{CC} = \text{Max.}$ , $f = f_{MAX} = 1/t_{RC}$		185		180	mA		
$I_{SB1}$	Automatic CE Power-Down Current —TTL Inputs	Max. $V_{CC}$ , $CE \geq V_{IH}$ $V_{IN} \geq V_{IH}$ or $V_{IN} \leq V_{IL}$ , $f = f_{MAX}$		40		40	mA		
$I_{SB2}$	Automatic CE Power-Down Current —CMOS Inputs	Max. $V_{CC}$ , $CE \geq V_{CC} - 0.3\text{V}$ , $V_{IN} \geq V_{CC} - 0.3\text{V}$ , or $V_{IN} \leq 0.3\text{V}$ , $f = 0$	Com'l		8		8	mA	
			Com'l	L		0.5		0.5	mA
			Ind'l			8		8	mA
			Ind'l	L		0.5		0.5	mA

**Capacitance<sup>[3]</sup>**

Parameter	Description	Test Conditions	Max.	Unit
$C_{IN}$	Input Capacitance	$T_A = 25^\circ\text{C}$ , $f = 1 \text{ MHz}$ , $V_{CC} = 5.0\text{V}$	8	pF
$C_{OUT}$	I/O Capacitance		8	pF

**Note:**

3. Tested initially and after any design or process changes that may affect these parameters.

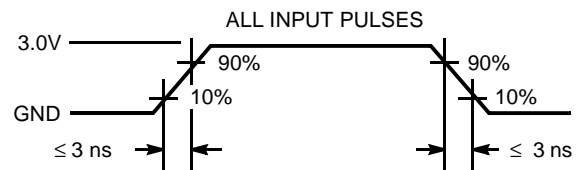
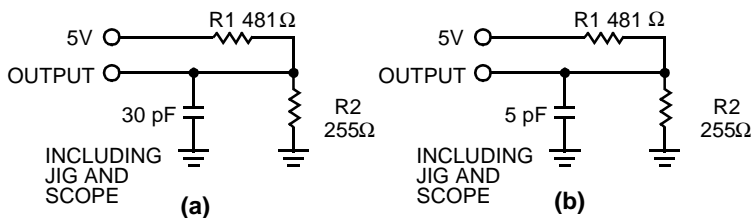
**AC Test Loads and Waveforms**

Equivalent to: THÉVENIN EQUIVALENT

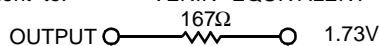

**Switching Characteristics<sup>[4]</sup> Over the Operating Range**

Parameter	Description	7C1049B-12		7C1049B-15		7C1049B-17		Unit
		Min.	Max.	Min.	Max.	Min.	Max.	
<b>Read Cycle</b>								
$t_{power}$	$V_{CC}$ (typical) to the First Access <sup>[5]</sup>	1		1		1		ms
$t_{RC}$	Read Cycle Time	12		15		17		ns
$t_{AA}$	Address to Data Valid		12		15		17	ns
$t_{OHA}$	Data Hold from Address Change	3		3		3		ns
$t_{ACE}$	$\overline{CE}$ LOW to Data Valid		12		15		17	ns
$t_{DOE}$	$\overline{OE}$ LOW to Data Valid		6		7		8	ns
$t_{LZOE}$	$\overline{OE}$ LOW to Low Z <sup>[7]</sup>	0		0		0		ns
$t_{HZOE}$	$\overline{OE}$ HIGH to High Z <sup>[6, 7]</sup>		6		7		7	ns
$t_{LZCE}$	$\overline{CE}$ LOW to Low Z <sup>[7]</sup>	3		3		3		ns
$t_{HZCE}$	$\overline{CE}$ HIGH to High Z <sup>[6, 7]</sup>		6		7		7	ns
$t_{PU}$	$\overline{CE}$ LOW to Power-Up	0		0		0		ns
$t_{PD}$	$\overline{CE}$ HIGH to Power-Down		12		15		17	ns
<b>Write Cycle<sup>[8, 9]</sup></b>								
$t_{WC}$	Write Cycle Time	12		15		17		ns
$t_{SCE}$	$\overline{CE}$ LOW to Write End	10		12		12		ns
$t_{AW}$	Address Set-Up to Write End	10		12		12		ns
$t_{HA}$	Address Hold from Write End	0		0		0		ns
$t_{SA}$	Address Set-Up to Write Start	0		0		0		ns
$t_{PWE}$	$\overline{WE}$ Pulse Width	10		12		12		ns
$t_{SD}$	Data Set-Up to Write End	7		8		8		ns
$t_{HD}$	Data Hold from Write End	0		0		0		ns
$t_{LZWE}$	$\overline{WE}$ HIGH to Low Z <sup>[7]</sup>	3		3		3		ns
$t_{HZWE}$	$\overline{WE}$ LOW to High Z <sup>[6, 7]</sup>		6		7		8	ns

**Notes:**

- Test conditions assume signal transition time of 3 ns or less, timing reference levels of 1.5V, input pulse levels of 0 to 3.0V, and output loading of the specified  $I_{OL}/I_{OH}$  and 30-pF load capacitance.
- This part has a voltage regulator which steps down the voltage from 5V to 3.3V internally.  $t_{power}$  time has to be provided initially before a read/write operation is started.
- $t_{HZOE}$ ,  $t_{HZCE}$ , and  $t_{HZWE}$  are specified with a load capacitance of 5 pF as in part (b) of AC Test Loads. Transition is measured  $\pm 500$  mV from steady-state voltage.
- At any given temperature and voltage condition,  $t_{HZCE}$  is less than  $t_{LZCE}$ ,  $t_{HZOE}$  is less than  $t_{LZOE}$ , and  $t_{HZWE}$  is less than  $t_{LZWE}$  for any given device.
- The internal write time of the memory is defined by the overlap of  $\overline{CE}$  LOW, and  $\overline{WE}$  LOW.  $\overline{CE}$  and  $\overline{WE}$  must be LOW to initiate a write, and the transition of either of these signals can terminate the write. The input data set-up and hold timing should be referenced to the leading edge of the signal that terminates the write.
- The minimum write cycle time for Write Cycle no. 3 ( $\overline{WE}$  controlled,  $\overline{OE}$  LOW) is the sum of  $t_{HZWE}$  and  $t_{SD}$ .

**Switching Characteristics<sup>[4]</sup> Over the Operating Range (continued)**

Parameter	Description	7C1049B-20		7C1049B-25		Unit
		Min.	Max.	Min.	Max.	
<b>Read Cycle</b>						
t <sub>power</sub>	V <sub>CC</sub> (typical) to the First Access <sup>[5]</sup>	1		1		1
t <sub>RC</sub>	Read Cycle Time	20		25		ns
t <sub>AA</sub>	Address to Data Valid		20		25	ns
t <sub>OHA</sub>	Data Hold from Address Change	3		5		ns
t <sub>ACE</sub>	$\overline{CE}$ LOW to Data Valid		20		25	ns
t <sub>DOE</sub>	$\overline{OE}$ LOW to Data Valid		8		10	ns
t <sub>LZOE</sub>	$\overline{OE}$ LOW to Low Z <sup>[7]</sup>	0		0		ns
t <sub>HZOE</sub>	$\overline{OE}$ HIGH to High Z <sup>[6, 7]</sup>		8		10	ns
t <sub>LZCE</sub>	$\overline{CE}$ LOW to Low Z <sup>[7]</sup>	3		5		ns
t <sub>HZCE</sub>	$\overline{CE}$ HIGH to High Z <sup>[6, 7]</sup>		8		10	ns
t <sub>PU</sub>	$\overline{CE}$ LOW to Power-Up	0		0		ns
t <sub>PD</sub>	$\overline{CE}$ HIGH to Power-Down		20		25	ns
<b>Write Cycle<sup>[8]</sup></b>						
t <sub>WC</sub>	Write Cycle Time	20		25		ns
t <sub>SCE</sub>	$\overline{CE}$ LOW to Write End	13		15		ns
t <sub>AW</sub>	Address Set-Up to Write End	13		15		ns
t <sub>HA</sub>	Address Hold from Write End	0		0		ns
t <sub>SA</sub>	Address Set-Up to Write Start	0		0		ns
t <sub>PWE</sub>	$\overline{WE}$ Pulse Width	13		15		ns
t <sub>SD</sub>	Data Set-Up to Write End	9		10		ns
t <sub>HD</sub>	Data Hold from Write End	0		0		ns
t <sub>LZWE</sub>	$\overline{WE}$ HIGH to Low Z <sup>[7]</sup>	3		5		ns
t <sub>HZWE</sub>	$\overline{WE}$ LOW to High Z <sup>[6, 7]</sup>		8		10	ns

**Data Retention Characteristics Over the Operating Range**

Parameter	Description	Conditions <sup>[11]</sup>		Min.	Max	Unit
V <sub>DR</sub>	V <sub>CC</sub> for Data Retention			2.0		V
I <sub>CCDR</sub>	Data Retention Current	Com'l	L	V <sub>CC</sub> = V <sub>DR</sub> = 3.0V, CE ≥ V <sub>CC</sub> - 0.3V V <sub>IN</sub> ≥ V <sub>CC</sub> - 0.3V or V <sub>IN</sub> ≤ 0.3V	200	μA
		Ind'l			1	mA
t <sub>CDR</sub> <sup>[3]</sup>	Chip Deselect to Data Retention Time			0		ns
t <sub>R</sub> <sup>[10]</sup>	Operation Recovery Time			t <sub>RC</sub>		ns

**Notes:**

10. t<sub>r</sub> ≤ 3 ns for the -12 and -15 speeds. t<sub>r</sub> ≤ 5 ns for the -20 ns and slower speeds.

11. No input may exceed V<sub>CC</sub> + 0.5V.

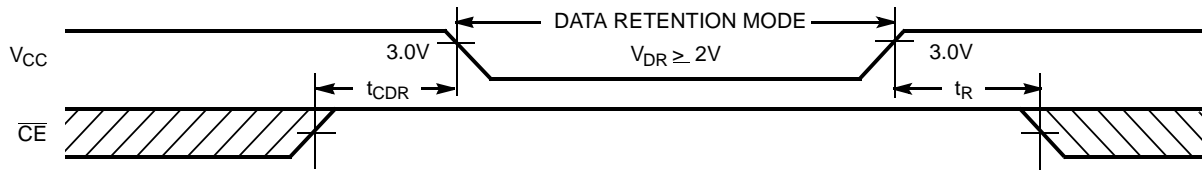
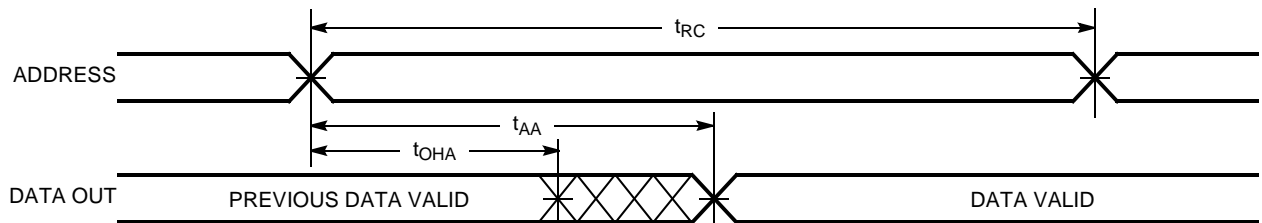
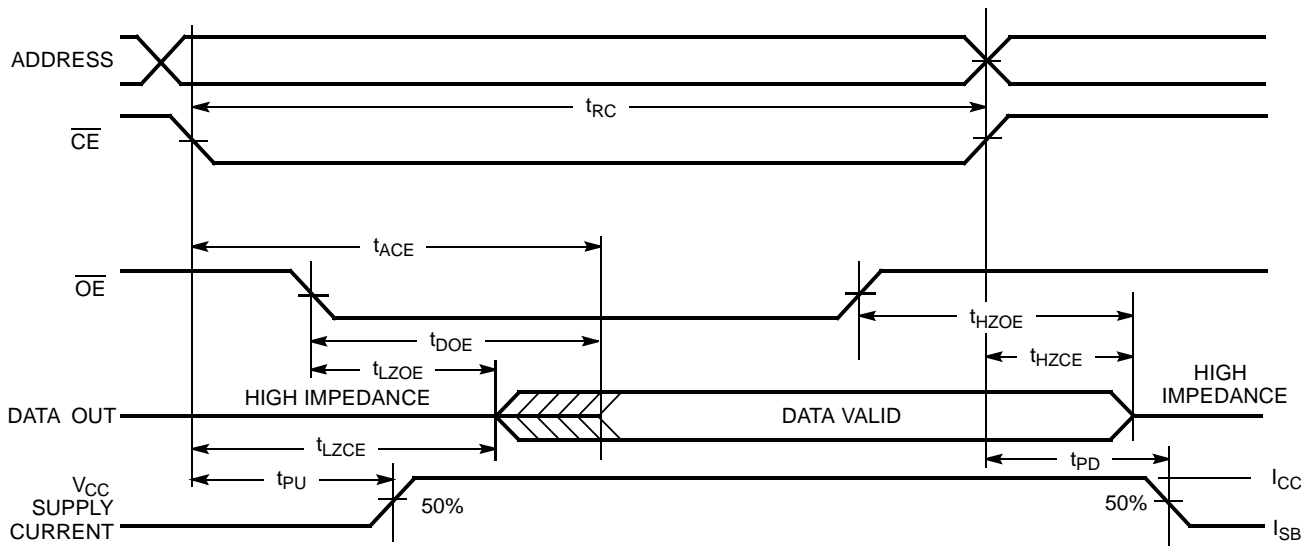
**Data Retention Waveform**

**Switching Waveforms**
**Read Cycle No. 1<sup>[12, 13]</sup>**

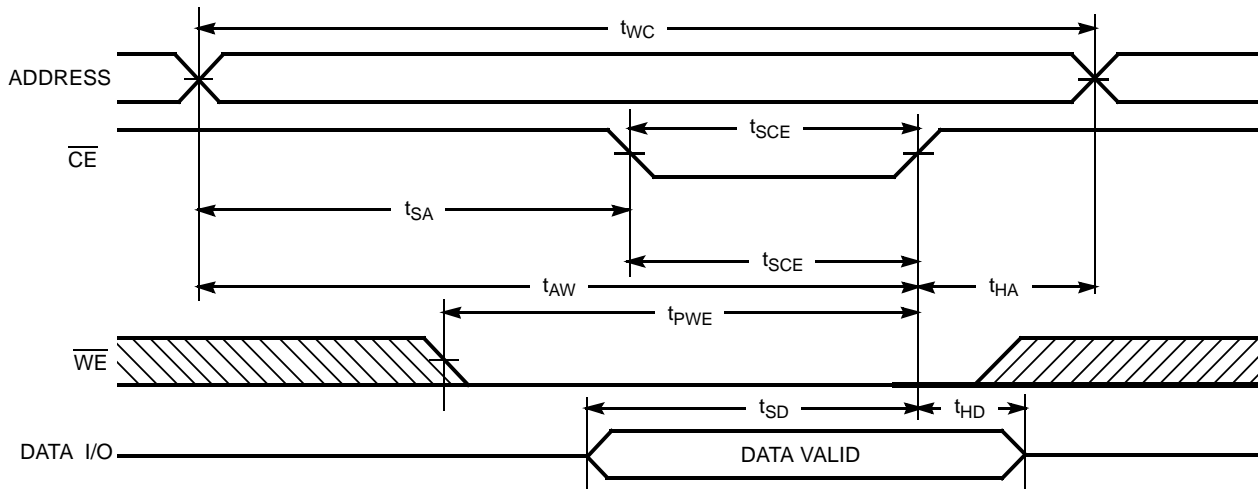
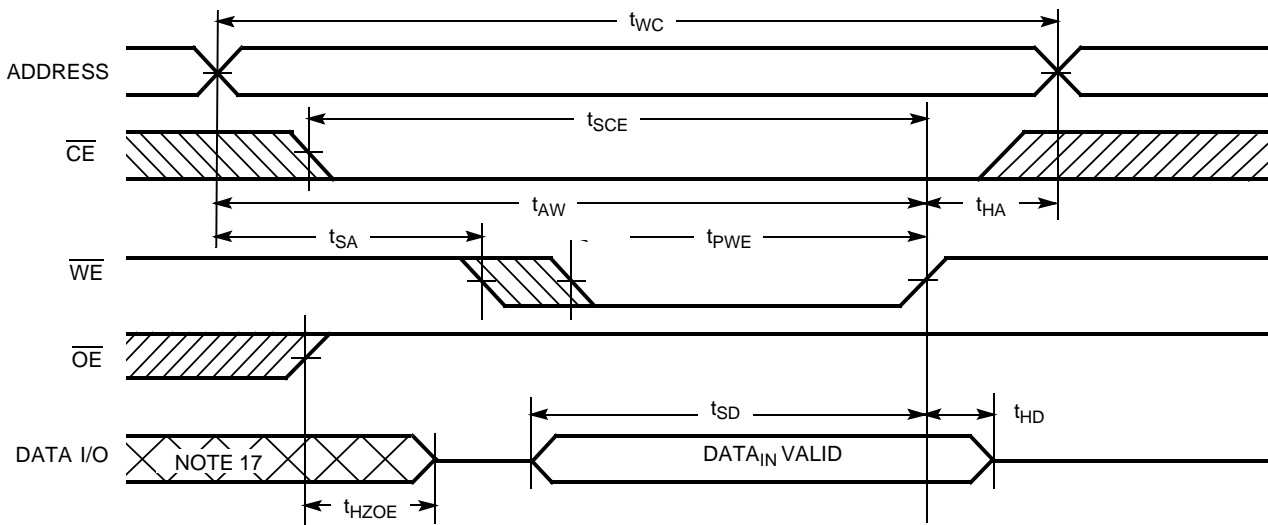
**Read Cycle No. 2 ( $\overline{OE}$  Controlled)<sup>[13, 14]</sup>**

**Notes:**

12. Device is continuously selected.  $\overline{OE}, \overline{CE} = V_{IL}$ .
13.  $\overline{WE}$  is HIGH for read cycle.
14. Address valid prior to or coincident with  $\overline{CE}$  transition LOW.

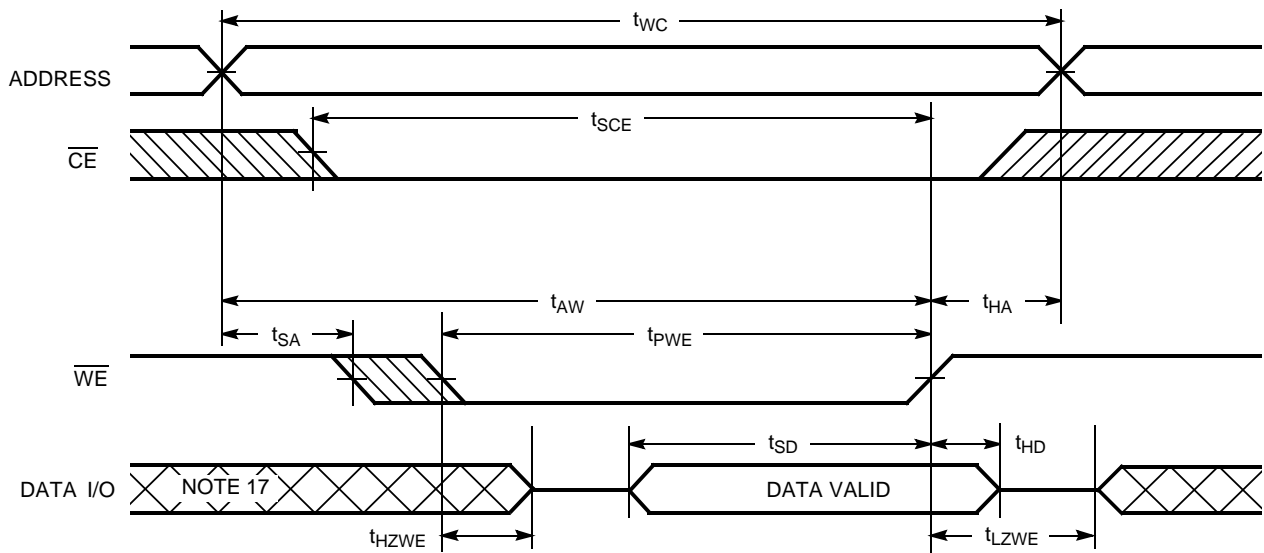
**Switching Waveforms (continued)**
**Write Cycle No. 1 ( $\overline{CE}$  Controlled)<sup>[15, 16]</sup>**

**Write Cycle No. 2 ( $\overline{WE}$  Controlled,  $\overline{OE}$  HIGH During Write)<sup>[15, 16]</sup>**

**Notes:**

15. Data I/O is high impedance if  $\overline{OE} = V_{IH}$ .
16. If  $\overline{CE}$  goes HIGH simultaneously with  $\overline{WE}$  going HIGH, the output remains in a high-impedance state.
17. During this period the I/Os are in the output state and input signals should not be applied.

**Switching Waveforms** (continued)

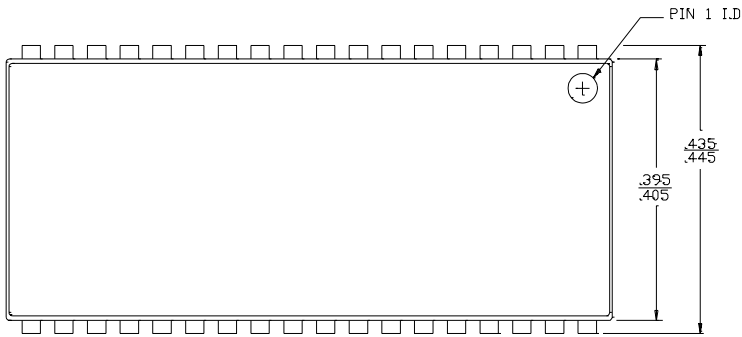
**Write Cycle No. 3 ( $\overline{\text{WE}}$  Controlled,  $\overline{\text{OE}}$  LOW)<sup>[16]</sup>**

**Ordering Information**

Speed (ns)	Ordering Code	Package Name	Package Type	Operating Range
12	CY7C1049B-12VC	V36	36-Lead (400-Mil) Molded SOJ	Commercial
15	CY7C1049B-15VC	V36	36-Lead (400-Mil) Molded SOJ	Industrial
	CY7C1049B-15VI	V36	36-Lead (400-Mil) Molded SOJ	
17	CY7C1049B-17VC	V36	36-Lead (400-Mil) Molded SOJ	Commercial
	CY7C1049BL-17VC	V36	36-Lead (400-Mil) Molded SOJ	Industrial
	CY7C1049B-17VI	V36	36-Lead (400-Mil) Molded SOJ	
20	CY7C1049B-20VC	V36	36-Lead (400-Mil) Molded SOJ	Commercial
	CY7C1049BL-20VC	V36	36-Lead (400-Mil) Molded SOJ	Industrial
	CY7C1049B-20VI	V36	36-Lead (400-Mil) Molded SOJ	
	CY7C1049BL-20VI	V36	36-Lead (400-Mil) Molded SOJ	
25	CY7C1049B-25VC	V36	36-Lead (400-Mil) Molded SOJ	Commercial
	CY7C1049BL-25VC	V36	36-Lead (400-Mil) Molded SOJ	Industrial
	CY7C1049B-25VI	V36	36-Lead (400-Mil) Molded SOJ	
	CY7C1049BL-25VI	V36	36-Lead (400-Mil) Molded SOJ	

**Package Diagram**
**36-Lead (400-Mil) Molded SOJ V36**

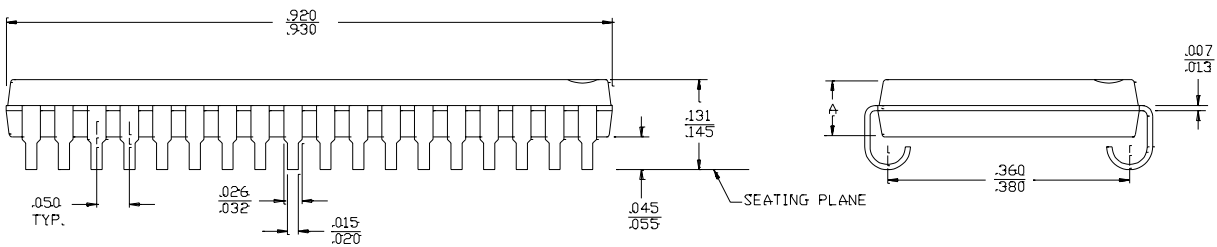
 DIMENSIONS IN INCHES MIN.  
MAX.

DIM. A	
ANAM	CSPI
.086	.095
.090	.115



51-85090-\*B

All product and company names mentioned in this document may be the trademarks of their respective holders.

**Document History Page**

<b>Document Title: CY7C1049B 512K x 8 Static RAM</b> <b>Document Number: 38-05169</b>				
<b>REV.</b>	<b>ECN NO.</b>	<b>Issue Date</b>	<b>Orig. of Change</b>	<b>Description of Change</b>
**	110209	12/02/01	SZV	Change from Spec number: 38-00937 to 38-05169
*A	116465	09/16/02	CEA	Add applications foot note to data sheet, page 1.

## Looking for pricing, stock, or lifecycle information?

Click below to explore more details on WIN SOURCE:

 [View CY7C1049B-20VC on WIN SOURCE](#)

 [Cypress Semiconductor Corp](#) Information

## Optimize Your Supply Chain with WIN SOURCE Solutions

-  Global Sourcing Solution
-  Obsolete Management
-  Cost Control Management
-  Shortage Management
-  Alternative Solution
-  Excess Inventory Management