



**THE DATASHEET OF
CY7C1019CV33-12VC**



1 Mbit (128K x 8) Static RAM

Features

- Temperature Ranges
 - Industrial: -40°C to 85°C
 - Automotive-A: -40°C to 85°C
- Pin and Function compatible with CY7C1019BV33
- High Speed
 - $t_{AA} = 10\text{ ns}$
- CMOS for optimum Speed and Power
- Data Retention at 2.0V
- Center Power/Ground Pinout
- Automatic Power Down when deselected
- Easy Memory Expansion with $\overline{\text{CE}}$ and $\overline{\text{OE}}$ Options
- Available in Pb-free and non Pb-free 48-Ball VFBGA, 32-Pin TSOP II and 400-mil SOJ Package

Functional Description

The CY7C1019CV33 is a high performance CMOS static RAM organized as 131,072 words by 8 bits. Easy memory expansion is provided by an active LOW Chip Enable ($\overline{\text{CE}}$), an active LOW Output Enable ($\overline{\text{OE}}$), and tristate drivers. This device has an automatic power down feature that significantly reduces power consumption when deselected.

Writing to the device is accomplished by taking Chip Enable ($\overline{\text{CE}}$) and Write Enable ($\overline{\text{WE}}$) inputs LOW. Data on the eight I/O pins (I/O_0 through I/O_7) is then written into the location specified on the address pins (A_0 through A_{16}).

Reading from the device is accomplished by taking Chip Enable ($\overline{\text{CE}}$) and Output Enable ($\overline{\text{OE}}$) LOW while forcing Write Enable ($\overline{\text{WE}}$) HIGH. Under these conditions, the contents of the memory location specified by the address pins will appear on the I/O pins.

The eight input/output pins (I/O_0 through I/O_7) are placed in a high impedance state when the device is deselected ($\overline{\text{CE}}$ HIGH), the outputs are disabled ($\overline{\text{OE}}$ HIGH), or during a write operation ($\overline{\text{CE}}$ LOW, and $\overline{\text{WE}}$ LOW).

Logic Block Diagram

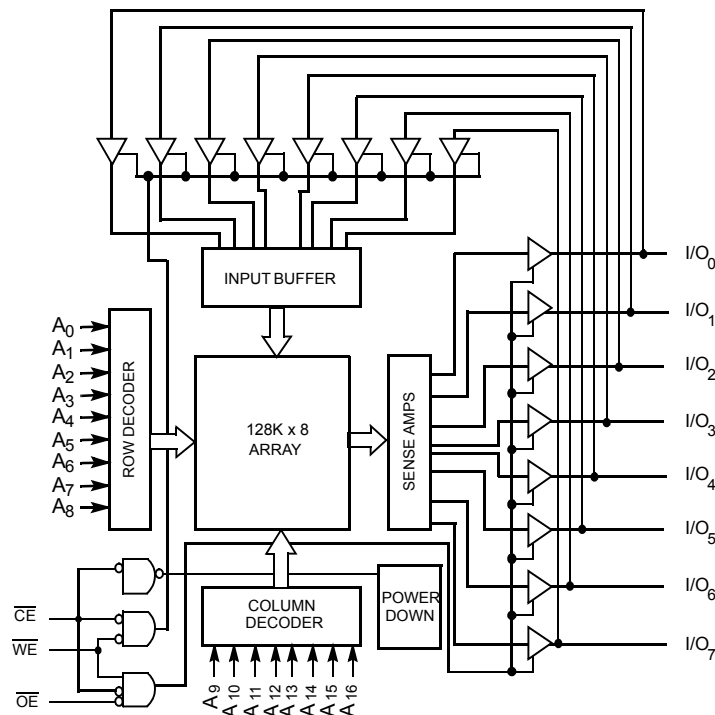

Selection Guide

Description	-10 (Industrial/ Auto-A)	-12 (Industrial)	-15 (Industrial)	Unit
Maximum Access Time	10	12	15	ns
Maximum Operating Current	80	75	70	mA
Maximum Standby Current	5	5	5	mA

Pin Configuration

Figure 1. 48-Ball VFPGA (Top View) [1]

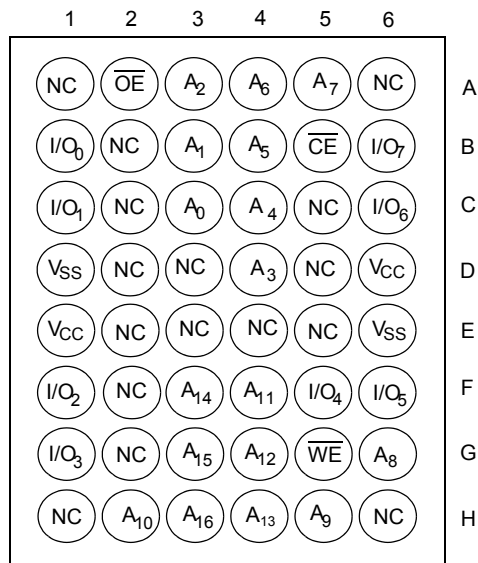
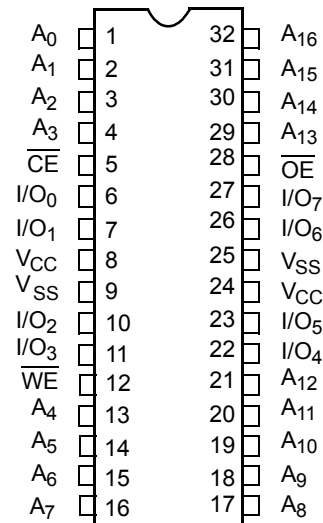

Figure 2. 32-Pin SOJ/TSOP II (Top View) [1]



Note

- 1. NC pins are not connected on the die.

Maximum Ratings

Exceeding maximum ratings may impair the useful life of the device. These user guidelines are not tested.

Storage Temperature -65°C to +150°C
 Ambient Temperature with Power Applied -55°C to +125°C
 Supply Voltage on V_{CC} to Relative GND^[2] -0.5V to +4.6V
 DC Voltage Applied to Outputs in High-Z State^[2] -0.5V to $V_{CC} + 0.5V$
 DC Input Voltage^[2] -0.5V to $V_{CC} + 0.5V$
 Current into Outputs (LOW) 20 mA

Static Discharge Voltage >2001V
 (per MIL-STD-883, Method 3015)

Latch up Current >200 mA

Operating Range

Range	Ambient Temperature	V_{CC}
Commercial	0°C to +70°C	3.3V ± 10%
Industrial	-40°C to +85°C	3.3V ± 10%
Automotive-A	-40°C to +85°C	3.3V ± 10%

Electrical Characteristics Over the Operating Range

Parameter	Description	Test Conditions	-10 (Industrial/Auto-A)		-12 (Industrial)		-15 (Industrial)		Unit
			Min	Max	Min	Max	Min	Max.	
V_{OH}	Output HIGH Voltage	$V_{CC} = \text{Min.}, I_{OH} = -4.0 \text{ mA}$	2.4		2.4		2.4		V
V_{OL}	Output LOW Voltage	$V_{CC} = \text{Min.}, I_{OL} = 8.0 \text{ mA}$		0.4		0.4		0.4	V
V_{IH}	Input HIGH Voltage		2.0	$V_{CC} + 0.3$	2.0	$V_{CC} + 0.3$	2.0	$V_{CC} + 0.3$	V
V_{IL}	Input LOW Voltage ^[2]		-0.3	0.8	-0.3	0.8	-0.3	0.8	V
I_{IX}	Input Leakage Current	$GND \leq V_I \leq V_{CC}$	-1	+1	-1	+1	-1	+1	μA
I_{OZ}	Output Leakage Current	$GND \leq V_I \leq V_{CC},$ Output Disabled	-1	+1	-1	+1	-1	+1	μA
I_{CC}	V_{CC} Operating Supply Current	$V_{CC} = \text{Max.}, I_{OUT} = 0 \text{ mA},$ $f = f_{MAX} = 1/t_{RC}$		80		75		70	mA
I_{SB1}	Automatic CE Power down Current —TTL Inputs	Max. $V_{CC}, \overline{CE} \geq V_{IH}$ $V_{IN} \geq V_{IH}$ or $V_{IN} \leq V_{IL}, f = f_{MAX}$		15		15		15	mA
I_{SB2}	Automatic CE Power down Current —CMOS Inputs	Max. $V_{CC},$ $\overline{CE} \geq V_{CC} - 0.3V,$ $V_{IN} \geq V_{CC} - 0.3V,$ or $V_{IN} \leq 0.3V, f = 0$		5		5		5	mA

Capacitance^[3]

Parameter	Description	Test Conditions	Max.	Unit
C_{IN}	Input Capacitance	$T_A = 25^\circ\text{C}, f = 1 \text{ MHz},$ $V_{CC} = 5.0V$	8	pF
C_{OUT}	Output Capacitance		8	pF

Notes

- V_{IL} (min.) = -2.0V for pulse durations of less than 20 ns.
- Tested initially and after any design or process changes that may affect these parameters.

Figure 3. AC Test Loads and Waveforms^[4]

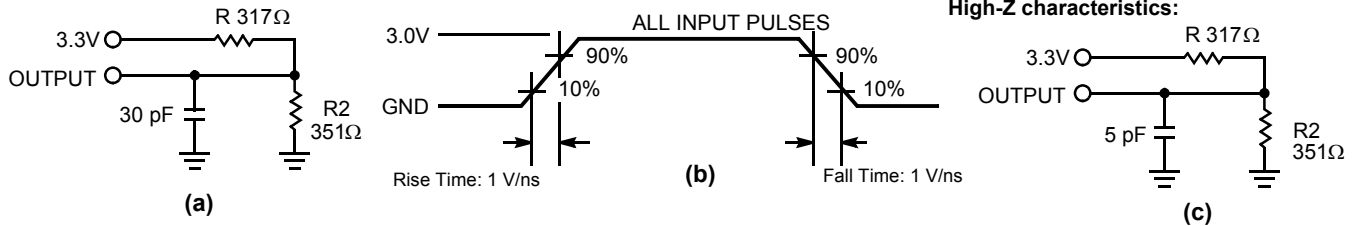

Switching Characteristics Over the Operating Range^[5]

Parameter	Description	-10 (Industrial/ Auto-A)		-12 (Industrial)		-15 (Industrial)		Unit
		Min	Max	Min	Max	Min	Max	
Read Cycle								
t_{RC}	Read Cycle Time	10		12		15		ns
t_{AA}	Address to Data Valid		10		12		15	ns
t_{OHA}	Data Hold from Address Change	3		3		3		ns
t_{ACE}	\overline{CE} LOW to Data Valid		10		12		15	ns
t_{DOE}	\overline{OE} LOW to Data Valid		5		6		7	ns
t_{LZOE}	\overline{OE} LOW to Low Z	0		0		0		ns
t_{HZOE}	\overline{OE} HIGH to High Z ^[6, 7]		5		6		7	ns
t_{LZCE}	\overline{CE} LOW to Low Z ^[7]	3		3		3		ns
t_{HZCE}	\overline{CE} HIGH to High Z ^[6, 7]		5		6		7	ns
t_{PU} ^[8]	\overline{CE} LOW to Power Up	0		0		0		ns
t_{PD} ^[8]	\overline{CE} HIGH to Power Down		10		12		15	ns
Write Cycle^[9, 10]								
t_{WC}	Write Cycle Time	10		12		15		ns
t_{SCE}	\overline{CE} LOW to Write End	8		9		10		ns
t_{AW}	Address Setup to Write End	8		9		10		ns
t_{HA}	Address Hold from Write End	0		0		0		ns
t_{SA}	Address Setup to Write Start	0		0		0		ns
t_{PWE}	\overline{WE} Pulse Width	7		8		10		ns
t_{SD}	Data Setup to Write End	5		6		8		ns
t_{HD}	Data Hold from Write End	0		0		0		ns
t_{LZWE}	\overline{WE} HIGH to Low Z ^[7]	3		3		3		ns
t_{HZWE}	\overline{WE} LOW to High Z ^[6, 7]		5		6		7	ns

Notes

- AC characteristics (except High-Z) for all speeds are tested using the Thevenin load shown in section (a) in Figure 3. High-Z characteristics are tested for all speeds using the test load shown in section (c) in Figure 3.
- Test conditions assume signal transition time of 3 ns or less, timing reference levels of 1.5V, input pulse levels of 0 to 3.0V.
- t_{HZOE} , t_{HZCE} , and t_{HZWE} are specified with a load capacitance of 5 pF as in part (d) of Figure 3. Transition is measured ± 500 mV from steady-state voltage.
- At any given temperature and voltage condition, t_{HZCE} is less than t_{LZCE} , t_{HZOE} is less than t_{LZOE} , and t_{HZWE} is less than t_{LZWE} for any given device.
- This parameter is guaranteed by design and is not tested.
- The internal write time of the memory is defined by the overlap of \overline{CE} LOW and \overline{WE} LOW. \overline{CE} and \overline{WE} must be LOW to initiate a write, and the transition of any of these signals can terminate the write. The input data setup and hold timing should be referenced to the leading edge of the signal that terminates the write.
- The minimum write cycle time for Write Cycle no. 3 (\overline{WE} controlled, \overline{OE} LOW) is the sum of t_{HZWE} and t_{SD} .

Switching Waveforms

Figure 4. Read Cycle No. 1^[11, 12]

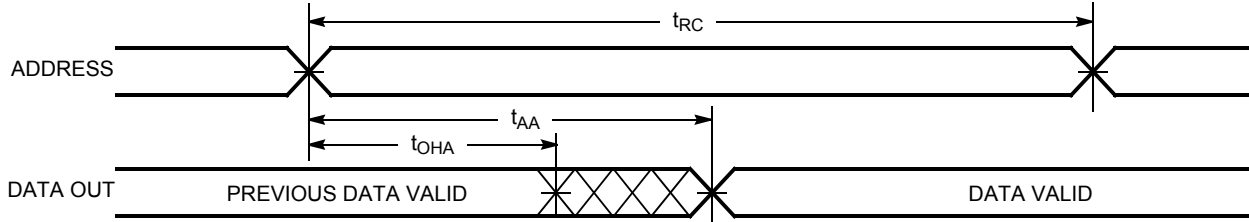

Figure 5. Read Cycle No. 2 (OE Controlled)^[14, 15]

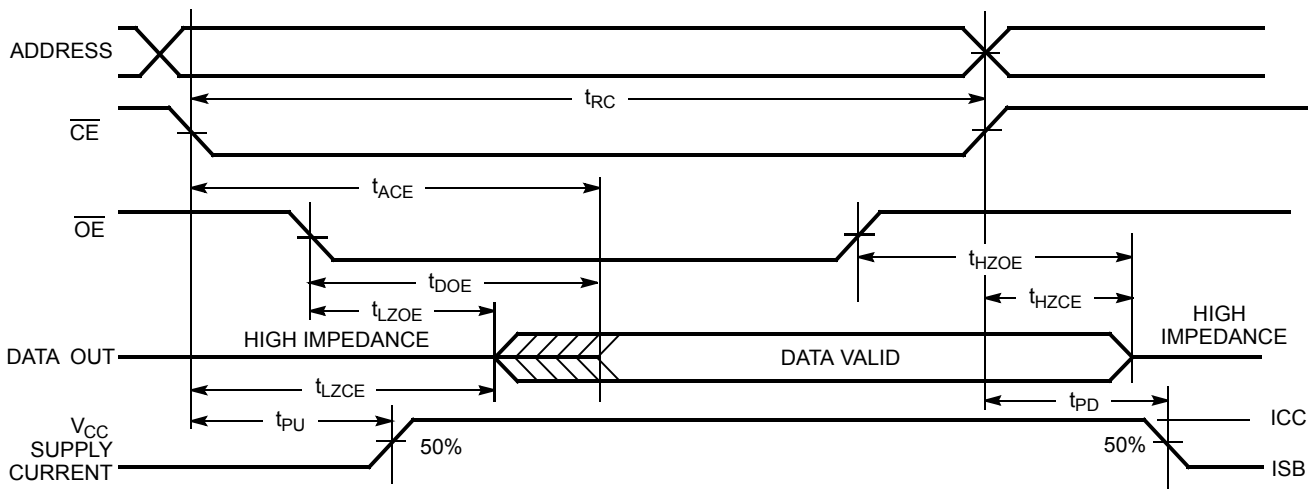
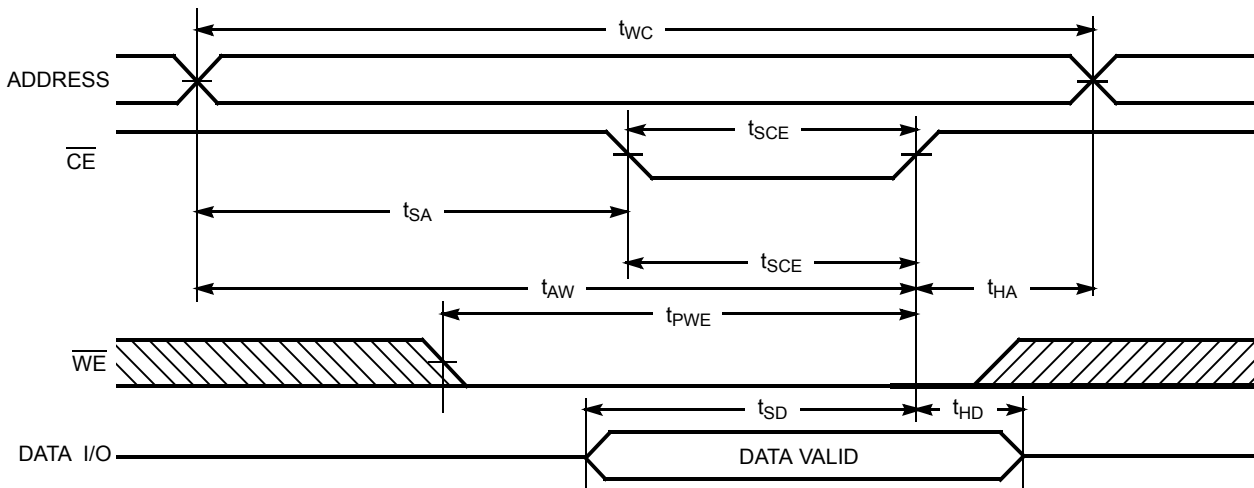

Figure 6. Write Cycle No. 1 (CE Controlled)^[14, 15]



Notes

- 11. Device is continuously selected. $\overline{OE}, \overline{CE} = V_{IL}$.
- 12. WE is HIGH for read cycle.
- 13. Address valid prior to or coincident with \overline{CE} transition LOW.
- 14. Data I/O is high impedance if $\overline{OE} = V_{IH}$.
- 15. If CE goes HIGH simultaneously with WE going HIGH, the output remains in a high impedance state.

Switching Waveforms (continued)

Figure 7. Write Cycle No. 2 (\overline{WE} Controlled, \overline{OE} HIGH During Write)^[14, 15]

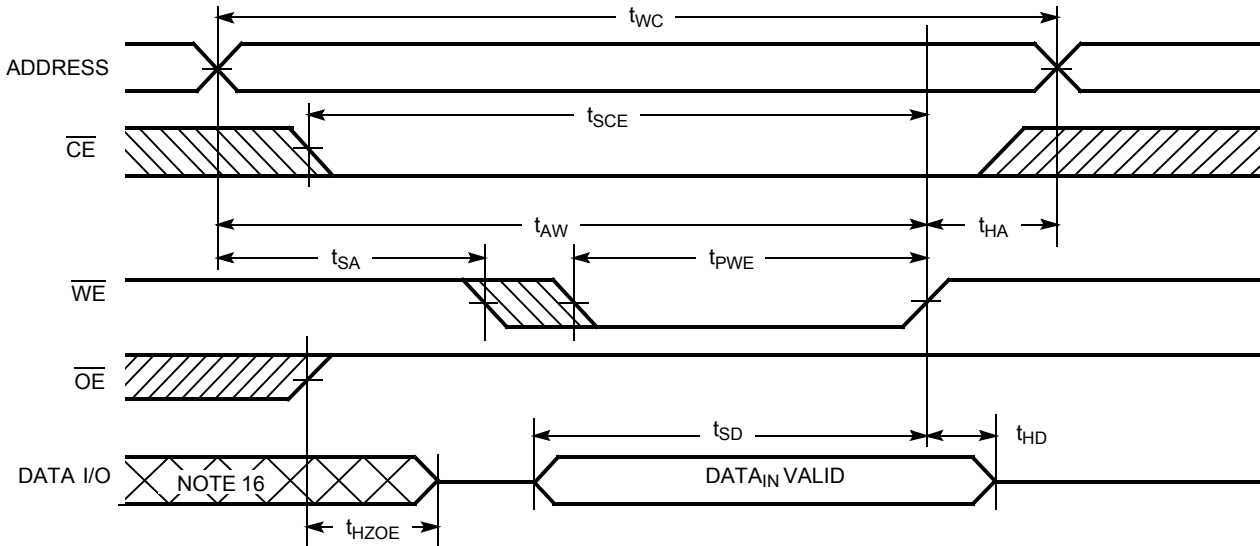
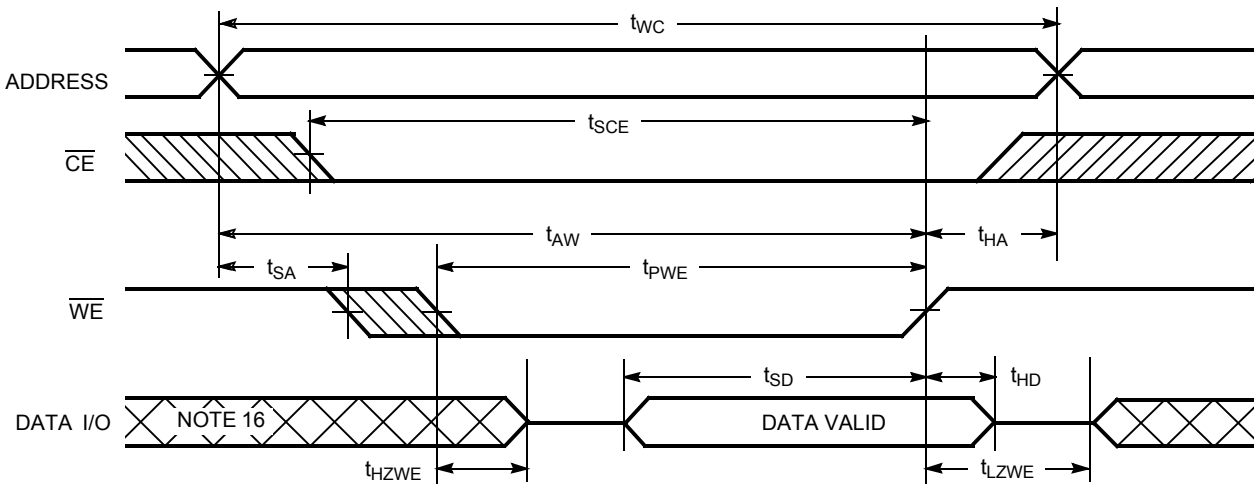

Figure 8. Write Cycle No. 3 (\overline{WE} Controlled, \overline{OE} LOW)^[14, 15]



Truth Table

CE	OE	WE	I/O ₀ -I/O ₇	Mode	Power
H	X	X	High Z	Power Down	Standby (I _{SB})
L	L	H	Data Out	Read	Active (I _{CC})
L	X	L	Data In	Write	Active (I _{CC})
L	H	H	High Z	Selected, Outputs Disabled	Active (I _{CC})

Note

16. During this period the I/Os are in the output state and input signals should not be applied.

Ordering Information

Speed (ns)	Ordering Code	Package Diagram	Package Type	Operating Range
10	CY7C1019CV33-10VC	51-85033	32-pin 400-Mil Molded SOJ	Commercial
	CY7C1019CV33-10ZXC	51-85095	32-pin TSOP II (Pb-Free)	
	CY7C1019CV33-10ZXI		32-pin TSOP II (Pb-Free)	Industrial
	CY7C1019CV33-10ZXA	51-85095	32-pin TSOP II (Pb-Free)	Automotive-A
12	CY7C1019CV33-12VC	51-85033	32-pin 400-Mil Molded SOJ	Commercial
	CY7C1019CV33-12ZC	51-85095	32-pin TSOP II	
	CY7C1019CV33-12ZXC		32-pin TSOP II (Pb-Free)	
	CY7C1019CV33-12VI	51-85033	32-pin 400-Mil Molded SOJ	Industrial
	CY7C1019CV33-12BVXI	51-85150	48-ball VFBGA (Pb-Free)	
15	CY7C1019CV33-15VC	51-85033	32-pin 400-Mil Molded SOJ	Commercial
	CY7C1019CV33-15VXC	51-85033	32-pin 400-Mil Molded SOJ (Pb-Free)	
	CY7C1019CV33-15ZXC	51-85095	32-pin TSOP II (Pb-Free)	Industrial
	CY7C1019CV33-15ZXI	51-85095	32-pin TSOP II (Pb-Free)	

Package Diagrams

Figure 9. 32-pin (400-Mil) Molded SOJ

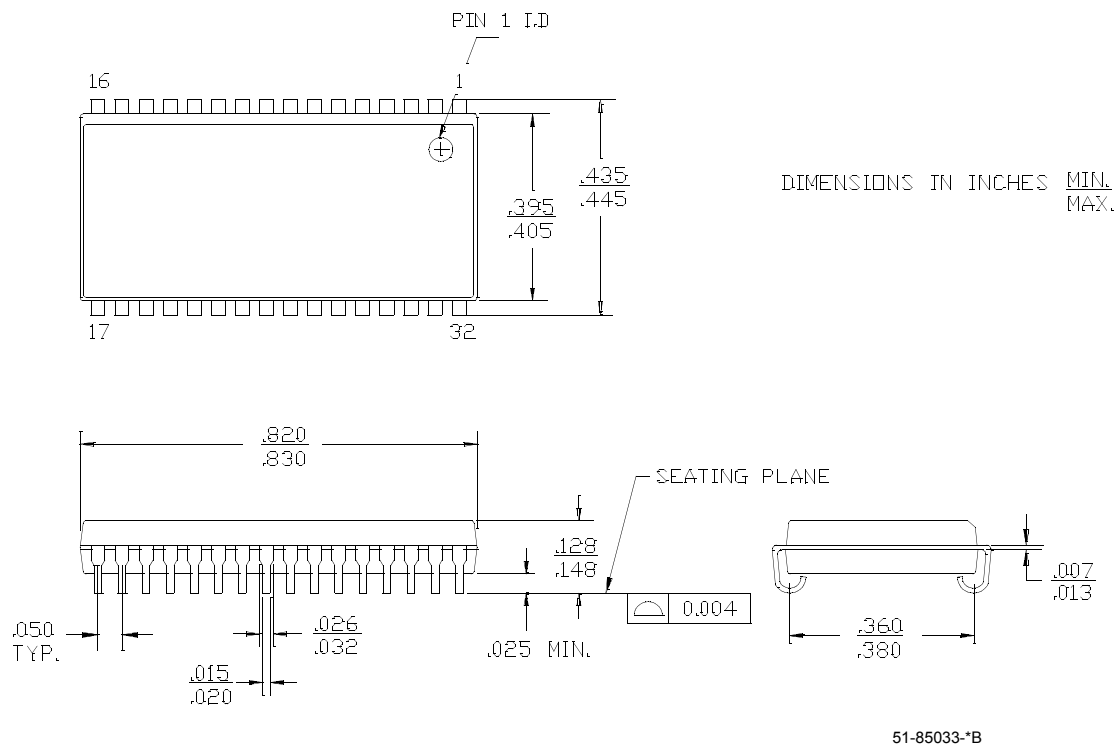
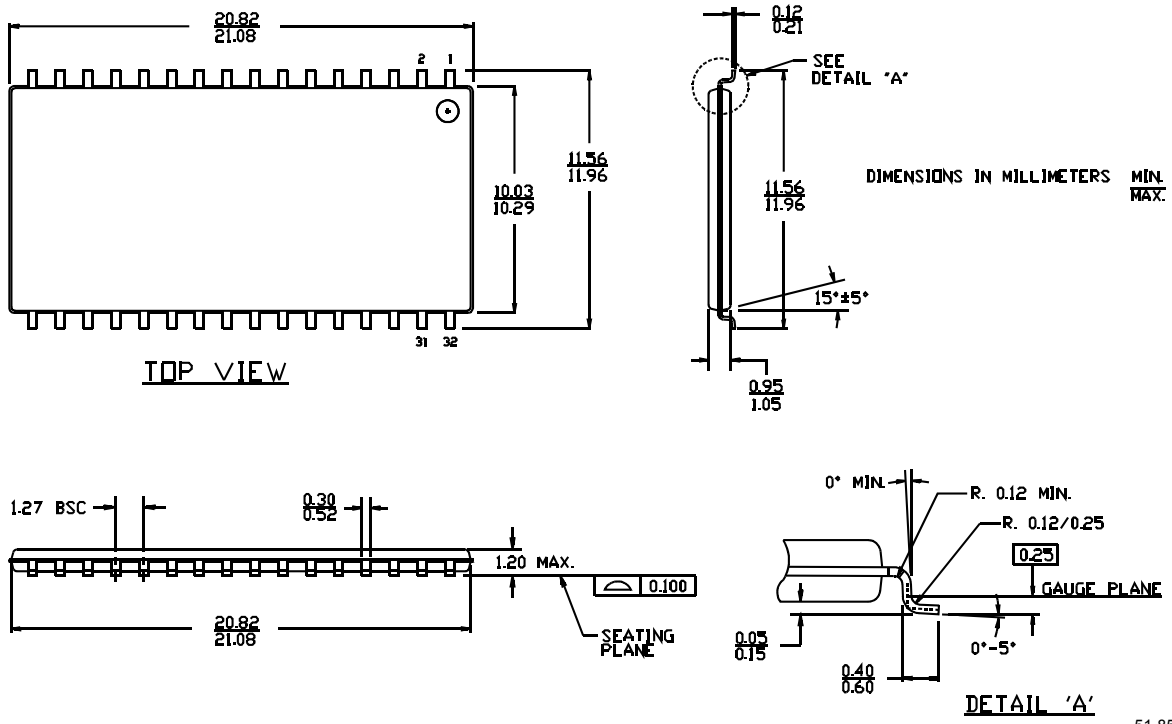
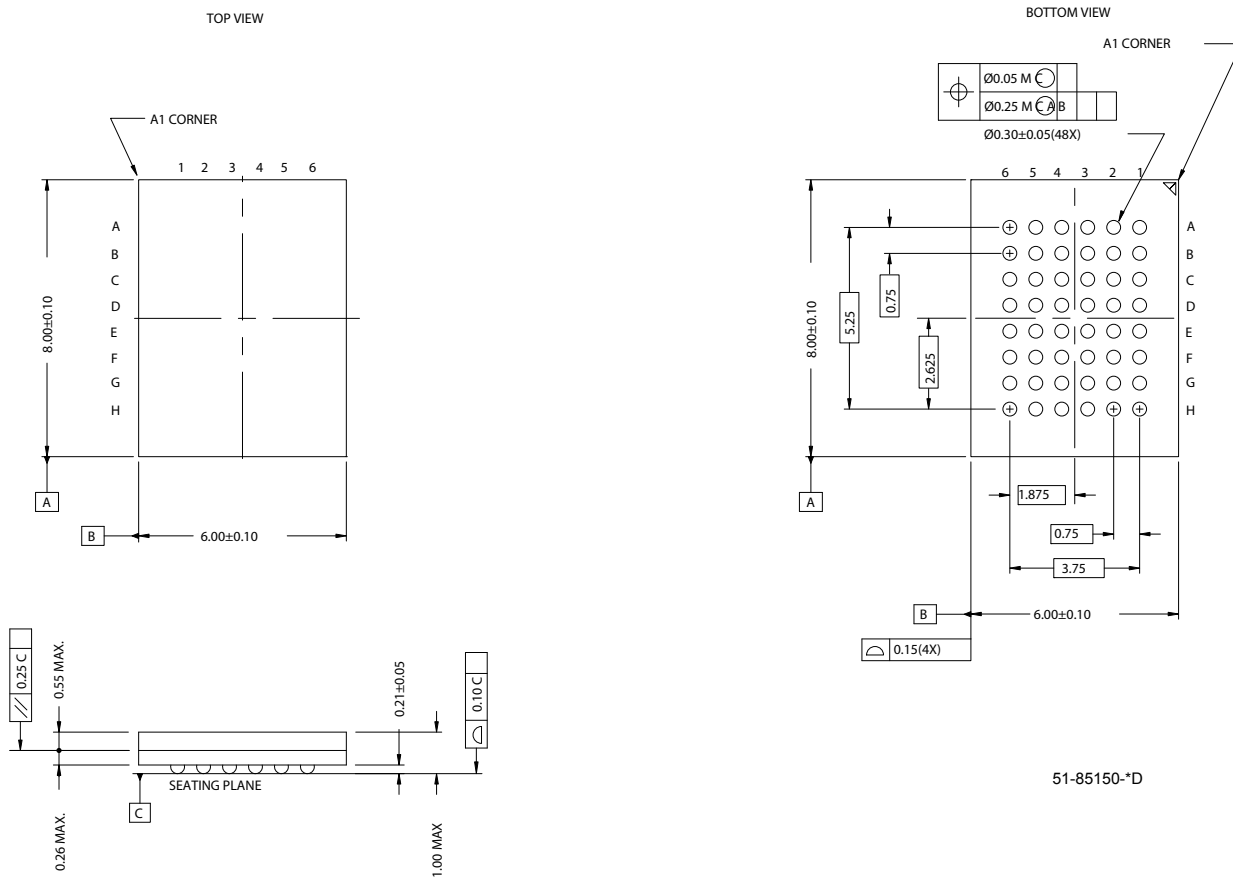

Figure 10. 32-Pin TSOP II



51-85095-**

Figure 11. 48-Ball VFBGA (6 x 8 x 1 mm)



Document History Page

Document Title: CY7C1019CV33 1 Mbit (128K x 8) Static RAM Document Number: 38-05130				
REV.	ECN NO.	Submission Date	Orig. of Change	Description of Change
**	109245	12/16/01	HGK	New Data Sheet
*A	113431	04/10/02	NSL	AC Test Loads split based on speed
*B	115047	08/01/02	HGK	Added TSOP II Package and I Temp. Improved I _{CC} limits
*C	119796	10/11/02	DFP	Updated standby current from 5 nA to 5 mA
*D	123030	12/17/02	DFP	Updated Truth Table to reflect single Chip Enable option
*E	419983	See ECN	NXR	Added 48-ball VFBGA Package Added lead-free parts in Ordering Information Table Replaced Package Name column with Package Diagram in the Ordering Information Table
*F	493543	See ECN	NXR	Removed 8 ns speed bin from Product offering Added note #1 on page #2 Changed the description of I _{IX} from Input Load Current to Input Leakage Current in DC Electrical Characteristics table Removed I _{OS} parameter from DC Electrical Characteristics table Updated Ordering Information
*G	2761448	09/09/2009	VKN	Included Automotive-A information

Sales, Solutions, and Legal Information

Worldwide Sales and Design Support

Cypress maintains a worldwide network of offices, solution centers, manufacturer’s representatives, and distributors. To find the office closest to you, visit us at cypress.com/sales.

Products

- PSoC psoc.cypress.com
- Clocks & Buffers clocks.cypress.com
- Wireless wireless.cypress.com
- Memories memory.cypress.com
- Image Sensors image.cypress.com

© Cypress Semiconductor Corporation, 2001-2009. The information contained herein is subject to change without notice. Cypress Semiconductor Corporation assumes no responsibility for the use of any circuitry other than circuitry embodied in a Cypress product. Nor does it convey or imply any license under patent or other rights. Cypress products are not warranted nor intended to be used for medical, life support, life saving, critical control or safety applications, unless pursuant to an express written agreement with Cypress. Furthermore, Cypress does not authorize its products for use as critical components in life-support systems where a malfunction or failure may reasonably be expected to result in significant injury to the user. The inclusion of Cypress products in life-support systems application implies that the manufacturer assumes all risk of such use and in doing so indemnifies Cypress against all charges.

Any Source Code (software and/or firmware) is owned by Cypress Semiconductor Corporation (Cypress) and is protected by and subject to worldwide patent protection (United States and foreign), United States copyright laws and international treaty provisions. Cypress hereby grants to licensee a personal, non-exclusive, non-transferable license to copy, use, modify, create derivative works of, and compile the Cypress Source Code and derivative works for the sole purpose of creating custom software and or firmware in support of licensee product to be used only in conjunction with a Cypress integrated circuit as specified in the applicable agreement. Any reproduction, modification, translation, compilation, or representation of this Source Code except as specified above is prohibited without the express written permission of Cypress.

Disclaimer: CYPRESS MAKES NO WARRANTY OF ANY KIND, EXPRESS OR IMPLIED, WITH REGARD TO THIS MATERIAL, INCLUDING, BUT NOT LIMITED TO, THE IMPLIED WARRANTIES OF MERCHANTABILITY AND FITNESS FOR A PARTICULAR PURPOSE. Cypress reserves the right to make changes without further notice to the materials described herein. Cypress does not assume any liability arising out of the application or use of any product or circuit described herein. Cypress does not authorize its products for use as critical components in life-support systems where a malfunction or failure may reasonably be expected to result in significant injury to the user. The inclusion of Cypress’ product in a life-support systems application implies that the manufacturer assumes all risk of such use and in doing so indemnifies Cypress against all charges.

Use may be limited by and subject to the applicable Cypress software license agreement.

Looking for pricing, stock, or lifecycle information?

Click below to explore more details on WIN SOURCE:

- [View CY7C1019CV33-12VC on WIN SOURCE](#)
- [Cypress Semiconductor Corp Information](#)

Optimize Your Supply Chain with WIN SOURCE Solutions

- ✓ Global Sourcing Solution
- ✓ Obsolete Management
- ✓ Cost Control Management
- ✓ Shortage Management
- ✓ Alternative Solution
- ✓ Excess Inventory Management