



**THE DATASHEET OF
CY7C037V-15AC**



3.3V 32K/64K x 16/18 Dual-Port Static RAM

Features

- True Dual-Ported memory cells which allow simultaneous access of the same memory location
- 32K x 16 organization (CY7C027V/027VN/027AV [1])
- 64K x 16 organization (CY7C028V)
- 32K x 18 organization (CY7C037V/037AV[2])
- 64K x 18 organization (CY7C038V)
- 0.35 micron CMOS for optimum speed and power
- High speed access: 15, 20, and 25 ns
- Low operating power
- Active: I_{CC} = 115 mA (typical)
- Standby: I_{SB3} = 10 μA (typical)
- Fully asynchronous operation
- Automatic power down
- Expandable data bus to 32/36 bits or more using Master/Slave chip select when using more than one device
- On-chip arbitration logic
- Semaphores included to permit software handshaking between ports
- INT flag for port-to-port communication
- Separate upper-byte and lower-byte control
- Dual chip enables
- Pin select for Master or Slave
- Commercial and Industrial temperature ranges
- 100-pin Pb-free TQFP and 100-pin TQFP

Logic Block Diagram

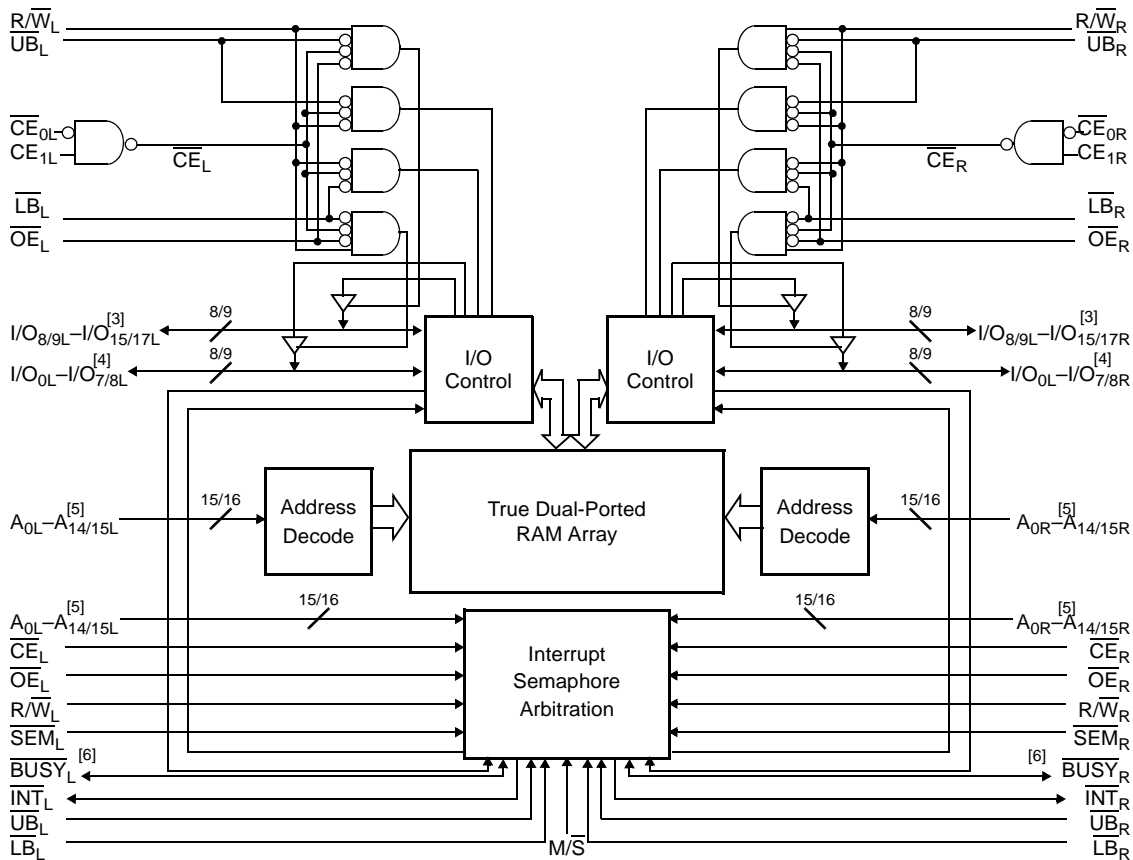

- Notes**
1. CY7C027V, CY7C027VN and CY7C027AV are functionally identical.
 2. CY7C037V and CY7C037AV are functionally identical.
 3. I/O₈-I/O₁₅ for x16 devices; I/O₉-I/O₁₇ for x18 devices.
 4. I/O₀-I/O₇ for x16 devices; I/O₀-I/O₈ for x18 devices.
 5. A₀-A₄ for 32K; A₀-A₁₅ for 64K devices.
 6. BUSY is an output in master mode and an input in slave mode.

Pin Configurations

Figure 1. 100-Pin TQFP (Top View)

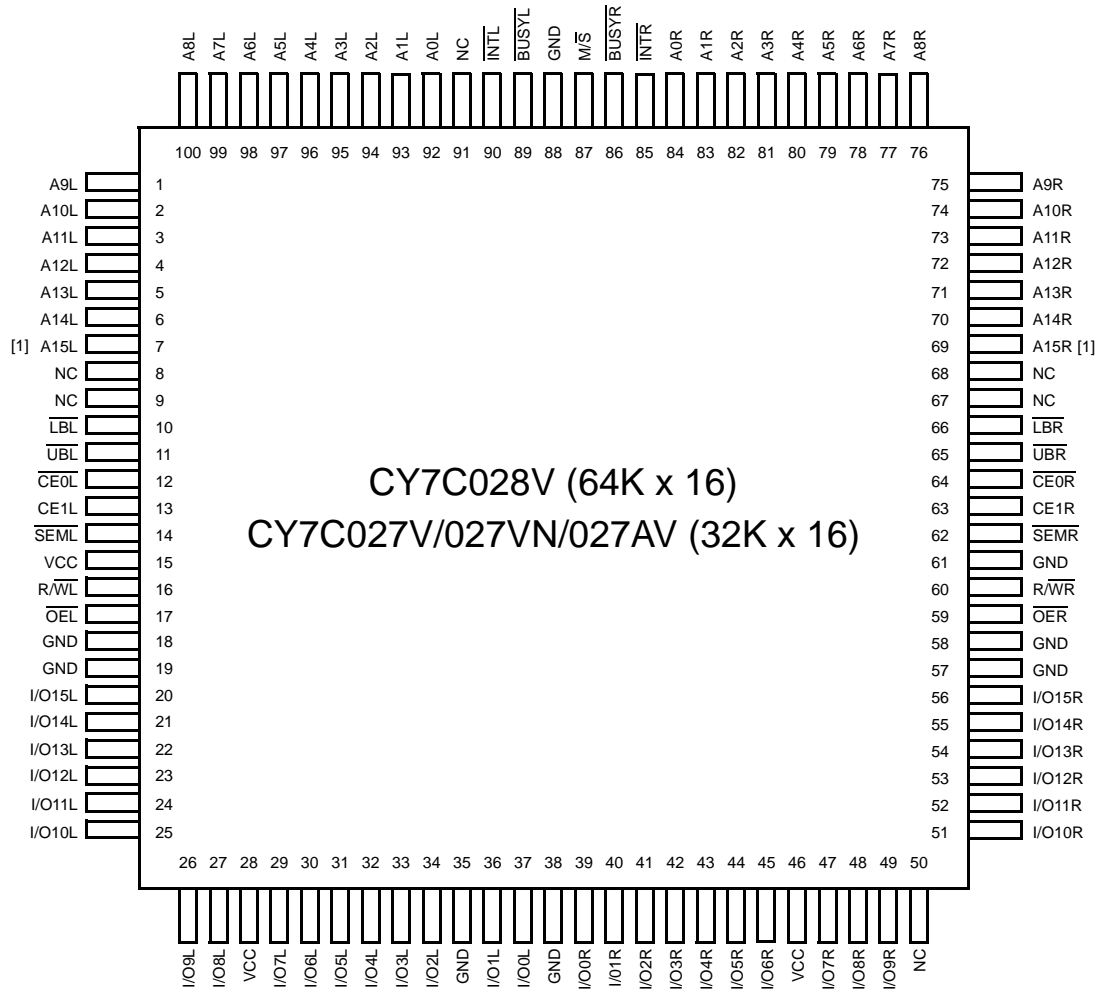

Note

1. This pin is NC for CY7C027V/027VN/027AV.

Pin Configurations (continued)

Figure 2. 100-Pin TQFP (Top View)

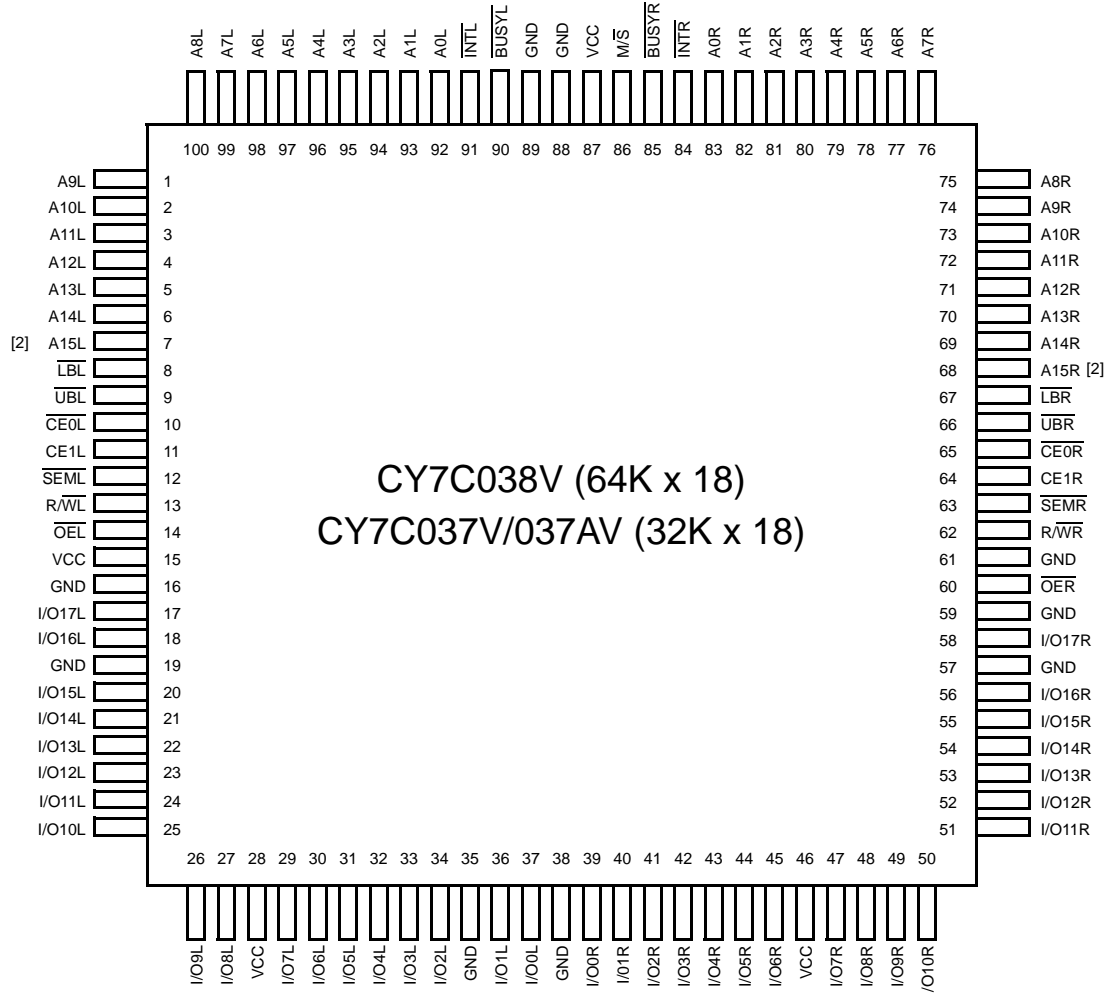

Selection Guide

Parameter	-15	-20	-25	Unit
Maximum Access Time	15	20	25	ns
Typical Operating Current	125	120	115	mA
Typical Standby Current for I _{SB1} (Both ports TTL level)	35	35	30	mA
Typical Standby Current for I _{SB3} (Both ports CMOS level)	10 μA	10 μA	10 μA	μA

Note

2. This pin is NC for CY7C037V/037AV.

Pin Definitions

Left Port	Right Port	Description
CE _{0L} , CE _{1L}	CE _{0R} , CE _{1R}	Chip Enable (CE is LOW when CE ₀ ≤ V _{IL} and CE ₁ ≥ V _{IH})
R/W _L	R/W _R	Read/Write Enable
OE _L	OE _R	Output Enable
A _{0L} -A _{15L}	A _{0R} -A _{15R}	Address (A ₀ -A ₁₄ for 32K; A ₀ -A ₁₅ for 64K devices)
I/O _{0L} -I/O _{17L}	I/O _{0R} -I/O _{17R}	Data Bus Input/Output (I/O ₀ -I/O ₁₅ for x16 devices; I/O ₀ -I/O ₁₇ for x18)
SEM _L	SEM _R	Semaphore Enable
UB _L	UB _R	Upper Byte Select (I/O ₈ -I/O ₁₅ for x16 devices; I/O ₉ -I/O ₁₇ for x18 devices)
LB _L	LB _R	Lower Byte Select (I/O ₀ -I/O ₇ for x16 devices; I/O ₀ -I/O ₈ for x18 devices)
INT _L	INT _R	Interrupt Flag
BUSY _L	BUSY _R	Busy Flag
M/S		Master or Slave Select
V _{CC}		Power
GND		Ground
NC		No Connect

Architecture

The CY7C027V/027VN/027AV/028V and CY7037V/037AV/038V consist of an array of 32K and 64K words of 16 and 18 bits each of dual-port RAM cells, I/O and address lines, and control signals (CE, OE, R/W). These control pins permit independent access for reads or writes to any location in memory. To handle simultaneous writes/reads to the same location, a BUSY pin is provided on each port. Two interrupt (INT) pins can be utilized for port-to-port communication. Two semaphore (SEM) control pins are used for allocating shared resources. With the M/S pin, the devices can function as a master (BUSY pins are outputs) or as a slave (BUSY pins are inputs). The devices also have an automatic power down feature controlled by CE. Each port is provided with its own output enable control (OE), which allows data to be read from the device.

Functional Description

The CY7C027V/027VN/027AV/028V and CY7037V/037AV/038V are low power CMOS 32K, 64K x 16/18 dual-port static RAMs. Various arbitration schemes are included on the devices to handle situations when multiple processors access the same piece of data. Two ports are provided, permitting independent, asynchronous access for reads and writes to any location in memory. The devices can be utilized as stand-alone 16/18-bit dual-port static RAMs or multiple devices can be combined to function as a 32/36-bit or wider master/slave dual-port static RAM. An M/S pin is provided for implementing 32/36-bit or wider memory applications without the need for separate master and slave devices or additional discrete logic. Application areas include interprocessor/multiprocessor designs, communications status buffering, and dual-port video/graphics memory.

Each port has independent control pins: chip enable (CE), read or write enable (R/W), and output enable (OE). Two flags are provided on each port (BUSY and INT). BUSY signals that the port is trying to access the same location currently being accessed by the other port. The interrupt flag (INT) permits communication between ports or

systems by means of a mail box. The semaphores are used to pass a flag, or token, from one port to the other to indicate that a shared resource is in use. The semaphore logic is comprised of eight shared latches. Only one side can control the latch (semaphore) at any time. Control of a semaphore indicates that a shared resource is in use. An automatic power down feature is controlled independently on each port by a chip select (CE) pin.

The CY7C027V/027VN/027AV/028V and CY7037V/037AV/038V are available in 100-pin Thin Quad Plastic Flatpacks (TQFP).

Write Operation

Data must be set up for a duration of t_{SD} before the rising edge of R/W to guarantee a valid write. A write operation is controlled by either the R/W pin (see Figure 7) or the CE pin (see Figure 8). Required inputs for non-contention operations are summarized in Table 1.

If a location is being written to by one port and the opposite port attempts to read that location, a port-to-port flowthrough delay must occur before the data is read on the output; otherwise the data read is not deterministic. Data is valid on the port t_{DD} after the data is presented on the other port.

Read Operation

When reading the device, the user must assert both the OE and CE pins. Data is available t_{ACE} after CE or t_{DOE} after OE is asserted. If the user wishes to access a semaphore flag, then the SEM pin must be asserted instead of the CE pin, and OE must also be asserted.

Interrupts

The upper two memory locations may be used for message passing. The highest memory location (7FFF for the CY7C027V/027VN/027AV/37V, FFFF for the CY7C028V/38V) is the mailbox for the right port and the second-highest memory location (7FFE for the CY7C027V/027VN/027AV/037V/037AV, FFFE for the CY7C028V/38V) is the mailbox for the left port. When one port writes to the other port's mailbox, an interrupt is

generated to the owner. The interrupt is reset when the owner reads the contents of the mailbox. The message is user defined.

Each port can read the other port's mailbox without resetting the interrupt. The active state of the busy signal (to a port) prevents the port from setting the interrupt to the winning port. Also, an active busy to a port prevents that port from reading its own mailbox and, thus, resetting the interrupt to it.

If an application does not require message passing, do not connect the interrupt pin to the processor's interrupt request input pin.

The operation of the interrupts and their interaction with Busy are summarized in [Table 2](#).

Busy

The CY7C027V/027VN/027AV/028V and CY7037V/037AV/038V provide on-chip arbitration to resolve simultaneous memory location access (contention). If both ports' CEs are asserted and an address match occurs within t_{PS} of each other, the busy logic determines which port has access. If t_{PS} is violated, one port definitely gains permission to the location, but it is not predictable which port gets that permission. \overline{BUSY} is asserted t_{BLA} after an address match or t_{BLC} after CE is taken LOW.

Master/Slave

A $\overline{M/S}$ pin is provided to expand the word width by configuring the device as either a master or a slave. The \overline{BUSY} output of the master is connected to the \overline{BUSY} input of the slave. This allows the device to interface to a master device with no external components. Writing to slave devices must be delayed until after the \overline{BUSY} input has settled (t_{BLC} or t_{BLA}), otherwise, the slave chip may begin a write cycle during a contention situation. When tied HIGH, the $\overline{M/S}$ pin allows the device to be used as a master and, therefore, the \overline{BUSY} line is an output. \overline{BUSY} can then be used to send the arbitration outcome to a slave.

Semaphore Operation

The CY7C027V/027VN/027AV/028V and CY7037V/037AV/038V provide eight semaphore latches, which are separate from the dual-port memory locations. Semaphores

are used to reserve resources that are shared between the two ports. The state of the semaphore indicates that a resource is in use. For example, if the left port wants to request a given resource, it sets a latch by writing a zero to a semaphore location. The left port then verifies its success in setting the latch by reading it. After writing to the semaphore, \overline{SEM} or \overline{OE} must be deasserted for t_{SOP} before attempting to read the semaphore. The semaphore value is available $t_{SWRD} + t_{DOE}$ after the rising edge of the semaphore write. If the left port was successful (reads a zero), it assumes control of the shared resource, otherwise (reads a one) it assumes the right port has control and continues to poll the semaphore. When the right side has relinquished control of the semaphore (by writing a one), the left side succeeds in gaining control of the semaphore. If the left side no longer requires the semaphore, a one is written to cancel its request.

Semaphores are accessed by asserting $\overline{SEM\ LOW}$. The \overline{SEM} pin functions as a chip select for the semaphore latches (CE must remain HIGH during $\overline{SEM\ LOW}$). A_{0-2} represents the semaphore address. \overline{OE} and \overline{RW} are used in the same manner as a normal memory access. When writing or reading a semaphore, the other address pins have no effect.

When writing to the semaphore, only I/O_0 is used. If a zero is written to the left port of an available semaphore, a one appears at the same semaphore address on the right port. That semaphore can now only be modified by the side showing zero (the left port in this case). If the left port now relinquishes control by writing a one to the semaphore, the semaphore is set to one for both sides. However, if the right port had requested the semaphore (written a zero) while the left port had control, the right port would immediately own the semaphore as soon as the left port released it. [Table 3](#) shows sample semaphore operations.

When reading a semaphore, all sixteen/eighteen data lines output the semaphore value. The read value is latched in an output register to prevent the semaphore from changing state during a write from the other port. If both ports attempt to access the semaphore within t_{SPS} of each other, the semaphore is definitely obtained by one side or the other, but there is no guarantee which side controls the semaphore.

Maximum Ratings

Exceeding maximum ratings may shorten the useful life of the device. User guidelines are not tested.

- Storage Temperature -65°C to +150°C
- Ambient Temperature with Power Applied -55°C to +125°C
- Supply Voltage to Ground Potential..... -0.5V to +4.6V
- DC Voltage Applied to Outputs in High-Z State -0.5V to $V_{CC}+0.5V$

- DC Input Voltage^[2] -0.5V to $V_{CC}+0.5V$
- Output Current into Outputs (LOW)..... 20 mA
- Static Discharge Voltage..... > 1100V
- Latch-up Current..... > 200 mA

Operating Range

Range	Ambient Temperature	V_{CC}
Commercial	0°C to +70°C	3.3V ± 300 mV
Industrial ^[3]	-40°C to +85°C	3.3V ± 300 mV

Electrical Characteristics Over the Operating Range

Parameter	Description	CY7C027V/027VN/027AV/028V/CY7C037V/037AV/038V									Unit
		-15			-20			-25			
		Min	Typ	Max	Min	Typ	Max	Min	Typ	Max	
V_{OH}	Output HIGH Voltage ($V_{CC}=\text{Min.}$, $I_{OH} = -4.0 \text{ mA}$)	2.4			2.4			2.4			V
V_{OL}	Output LOW Voltage ($V_{CC}=\text{Min.}$, $I_{OH} = +4.0 \text{ mA}$)			0.4			0.4			0.4	V
V_{IH}	Input HIGH Voltage	2.2			2.2			2.2			V
V_{IL}	Input LOW Voltage			0.8			0.8			0.8	V
I_{IX}	Input Leakage Current	-5		5	-5		5	-5		5	μA
I_{OZ}	Output Leakage Current	-10		10	-10		10	-10		10	μA
I_{CC}	Operating Current ($V_{CC}=\text{Max.}$ $I_{OUT}=0$ mA) Outputs Disabled	Com'l.	125	185		120	175		115	165	mA
		Ind. ^[3]				140	195				mA
I_{SB1}	Standby Current (Both Ports TTL Level) CE_L & $CE_R \geq V_{IH}$, $f=f_{MAX}$	Com'l.	35	50		35	45		30	40	mA
		Ind. ^[3]				45	55				mA
I_{SB2}	Standby Current (One Port TTL Level) CE_L $CE_R \geq V_{IH}$, $f=f_{MAX}$	Com'l.	80	120		75	110		65	95	mA
		Ind. ^[3]				85	120				mA
I_{SB3}	Standby Current (Both Ports CMOS Level) CE_L & $CE_R \geq V_{CC}-0.2V$, $f=0$	Com'l.	10	250		10	250		10	250	μA
		Ind. ^[3]				10	250				μA
I_{SB4}	Standby Current (One Port CMOS Level) CE_L $CE_R \geq V_{IH}$, $f=f_{MAX}$ ^[4]	Com'l.	75	105		70	95		60	80	mA
		Ind. ^[3]				80	105				mA

Capacitance^[5]

Parameter	Description	Test Conditions	Max	Unit
C_{IN}	Input Capacitance	$T_A = 25^\circ\text{C}$, $f = 1 \text{ MHz}$, $V_{CC} = 3.3V$	10	pF
C_{OUT}	Output Capacitance		10	pF

Notes

2. Pulse width < 20 ns.
3. Industrial parts are available in CY7C028V and CY7C038V only.
4. $f_{MAX} = 1/t_{RC}$ = All inputs cycling at $f = 1/t_{RC}$ (except output enable). $f = 0$ means no address or control lines change. This applies only to inputs at CMOS level standby I_{SB3} .
5. Tested initially and after any design or process changes that may affect these parameters.

Figure 3. AC Test Loads and Waveforms

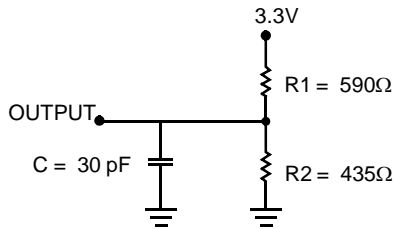

(a) Normal Load (Load 1)

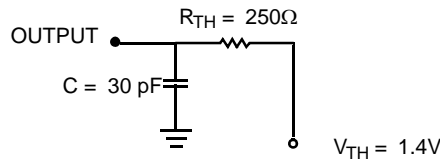

(b) Thévenin Equivalent (Load 1)

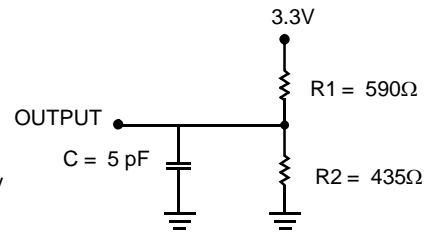

(c) Three-State Delay (Load 2)
(Used for t_{LZ} , t_{HZ} , t_{HZWE} , & t_{LZWE} including scope and jig)

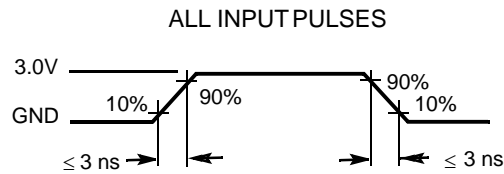

Switching Characteristics Over the Operating Range^[6]

Parameter	Description	CY7C027V/027VN/027AV/028V/ CY7C037V/037AV/038V						Unit
		-15		-20		-25		
		Min	Max	Min	Max	Min	Max	
Read Cycle								
t_{RC}	Read Cycle Time	15		20		25		ns
t_{AA}	Address to Data Valid		15		20		25	ns
t_{OHA}	Output Hold From Address Change	3		3		3		ns
$t_{ACE}^{[7]}$	CE LOW to Data Valid		15		20		25	ns
t_{DOE}	OE LOW to Data Valid		10		12		13	ns
$t_{LZOE}^{[8,9,10]}$	OE LOW to Low Z	3		3		3		ns
$t_{HZOE}^{[8,9,10]}$	OE HIGH to High Z		10		12		15	ns
$t_{LZCE}^{[8,9,10]}$	CE LOW to Low Z	3		3		3		ns
$t_{HZCE}^{[8,9,10]}$	CE HIGH to High Z		10		12		15	ns
$t_{PU}^{[10]}$	CE LOW to Power Up	0		0		0		ns
$t_{PD}^{[10]}$	CE HIGH to Power Down		15		20		25	ns
$t_{ABE}^{[7]}$	Byte Enable Access Time		15		20		25	ns
Write Cycle								
t_{WC}	Write Cycle Time	15		20		25		ns
$t_{SCE}^{[7]}$	CE LOW to Write End	12		16		20		ns
t_{AW}	Address Valid to Write End	12		16		20		ns
t_{HA}	Address Hold From Write End	0		0		0		ns
$t_{SA}^{[7]}$	Address Setup to Write Start	0		0		0		ns
t_{PWE}	Write Pulse Width	12		17		22		ns
t_{SD}	Data Setup to Write End	10		12		15		ns

Notes

- Test conditions assume signal transition time of 3 ns or less, timing reference levels of 1.5V, input pulse levels of 0 to 3.0V, and output loading of the specified I_{OL}/I_{OH} and 30 pF load capacitance.
- To access RAM, $\overline{CE}=L$, $\overline{UB}=L$, $\overline{SEM}=H$. To access semaphore, $\overline{CE}=H$ and $\overline{SEM}=L$. Either condition must be valid for the entire t_{SCE} time.
- At any given temperature and voltage condition for any given device, t_{HZCE} is less than t_{LZCE} and t_{HZOE} is less than t_{LZOE} .
- Test conditions used are Load 2.
- This parameter is guaranteed by design, but it is not production tested. For information on port-to-port delay through RAM cells from writing port to reading port, refer to Figure 11.

Switching Characteristics Over the Operating Range^[6](continued)

Parameter	Description	CY7C027V/027VN/027AV/028V/ CY7C037V/037AV/038V						Unit
		-15		-20		-25		
		Min	Max	Min	Max	Min	Max	
t _{HD}	Data Hold From Write End	0		0		0		ns
t _{HZWE} ^[9,10]	R/W LOW to High Z		10		12		15	ns
t _{LZWE} ^[9,10]	R/W HIGH to Low Z	3		3		3		ns
t _{WDD} ^[36]	Write Pulse to Data Delay		30		40		50	ns
t _{DDD} ^[36]	Write Data Valid to Read Data Valid		25		30		35	ns
Busy Timing ^[11]								
t _{BLA}	BUSY LOW from Address Match		15		20		20	ns
t _{BHA}	BUSY HIGH from Address Mismatch		15		20		20	ns
t _{BLC}	BUSY LOW from CE LOW		15		20		20	ns
t _{BHC}	BUSY HIGH from CE HIGH		15		16		17	ns
t _{PS}	Port Setup for Priority	5		5		5		ns
t _{WB}	R/W HIGH after BUSY (Slave)	0		0		0		ns
t _{WH}	R/W HIGH after BUSY HIGH (Slave)	13		15		17		ns
t _{BDD} ^[13]	BUSY HIGH to Data Valid		15		20		25	ns
Interrupt Timing ^[11]								
t _{INS}	INT Set Time		15		20		20	ns
t _{INR}	INT Reset Time		15		20		20	ns
Semaphore Timing								
t _{SOP}	SEM Flag Update Pulse (OE or SEM)	10		10		12		ns
t _{SWRD}	SEM Flag Write to Read Time	5		5		5		ns
t _{SPS}	SEM Flag Contention Window	5		5		5		ns
t _{SAA}	SEM Address Access Time		15		20		25	ns

Data Retention Mode

The CY7C027V/027VN/027AV/028V and CY7037V/037AV/038V are designed with battery backup in mind. Data retention voltage and supply current are guaranteed over temperature. The following rules ensure data retention:

1. Chip enable (\overline{CE}) must be held HIGH during data retention, within V_{CC} to $V_{CC} - 0.2V$.
2. \overline{CE} must be kept between $V_{CC} - 0.2V$ and 70% of V_{CC} during the power up and power down transitions.
3. The RAM can begin operation $>t_{RC}$ after V_{CC} reaches the minimum operating voltage (3.0 volts).

Timing

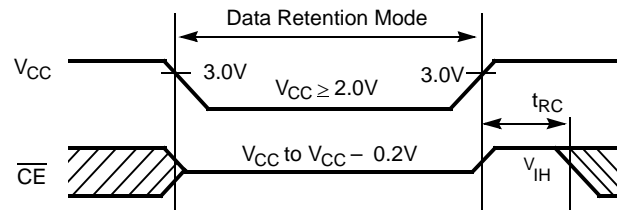

Parameter	Test Conditions ^[14]	Max	Unit
ICC _{DR1}	At V _{CCDR} = 2V	50	μA

Notes

11. For information on port-to-port delay through RAM cells from writing port to reading port, refer to Figure 11 waveform.
12. Test conditions used are Load 1.
13. t_{BDD} is a calculated parameter and is the greater of t_{WDD}-t_{PWE} (actual) or t_{DDD}-t_{SD} (actual).
14. CE = V_{CC}, V_{in} = GND to V_{CC}, T_A = 25° C. This parameter is guaranteed but not tested.

Switching Waveforms

Figure 4. Read Cycle No. 1 (Either Port Address Access)^[15, 16, 17]

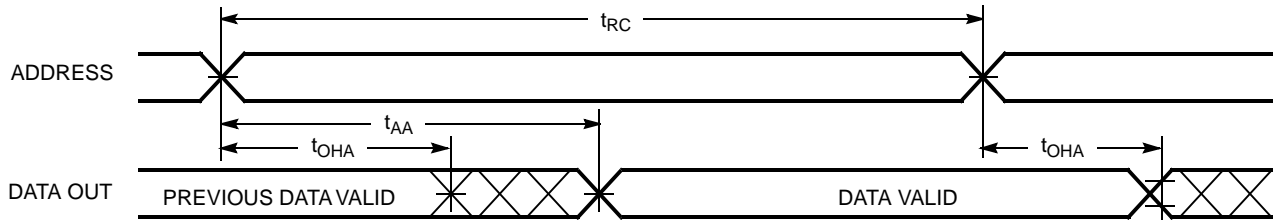

Figure 5. Read Cycle No. 2 (Either Port $\overline{\text{CE}}/\overline{\text{OE}}$ Access)^[15, 18, 19]

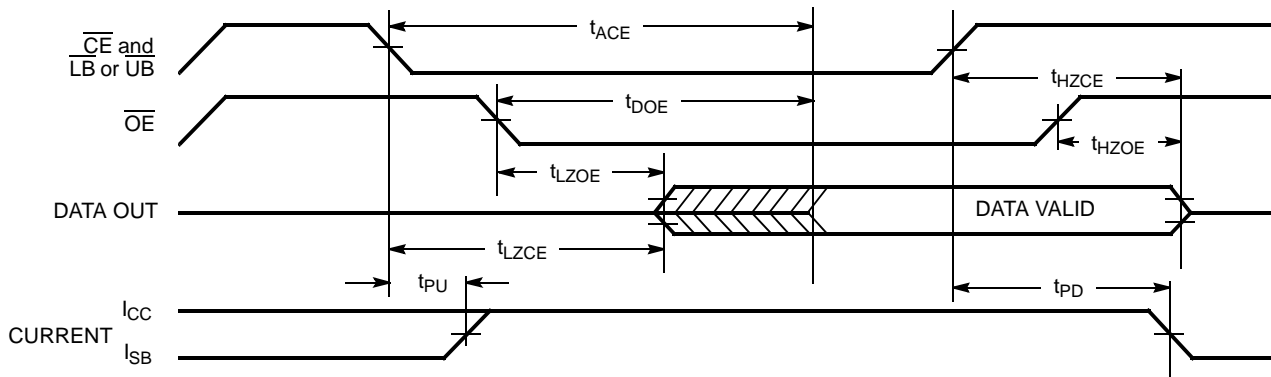
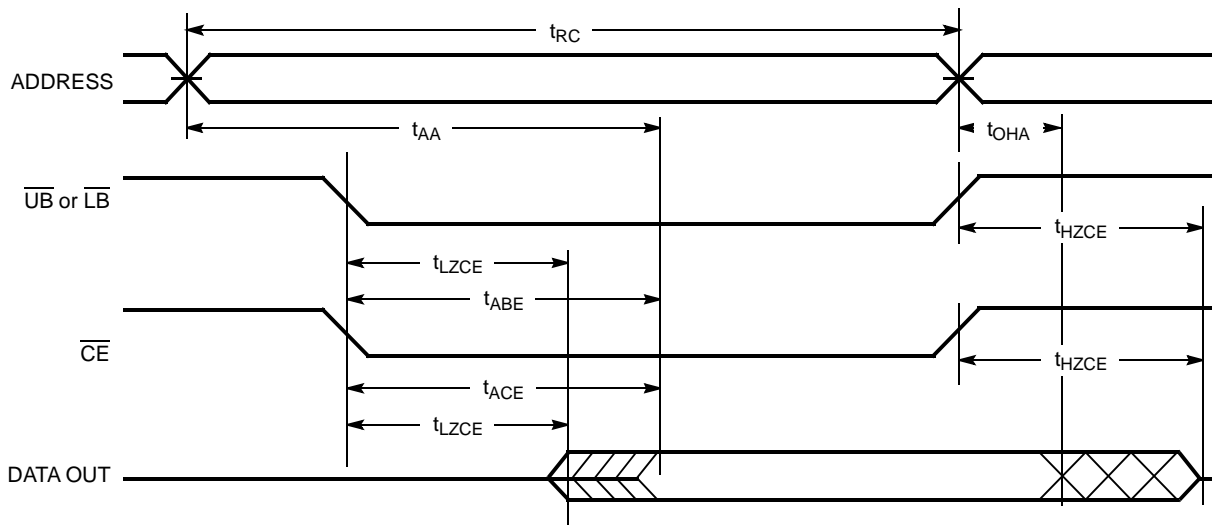

Figure 6. Read Cycle No. 3 (Either Port)^[15, 17, 18, 19]



Notes

15. R/W is HIGH for read cycles.
16. Device is continuously selected $\overline{\text{CE}} = V_{IL}$ and $\overline{\text{UB}}$ or $\overline{\text{LB}} = V_{IL}$. This waveform cannot be used for semaphore reads.
17. $\text{OE} = V_{IL}$.
18. Address valid prior to or coincident with $\overline{\text{CE}}$ transition LOW.
19. To access RAM, $\text{CE} = V_{IL}$, $\overline{\text{UB}}$ or $\overline{\text{LB}} = V_{IL}$, $\text{SEM} = V_{IH}$. To access semaphore, $\overline{\text{CE}} = V_{IH}$, $\overline{\text{SEM}} = V_{IL}$.

Switching Waveforms(continued)

Figure 7. Write Cycle No. 1: $\overline{R/W}$ Controlled Timing^[20, 21, 22, 23]

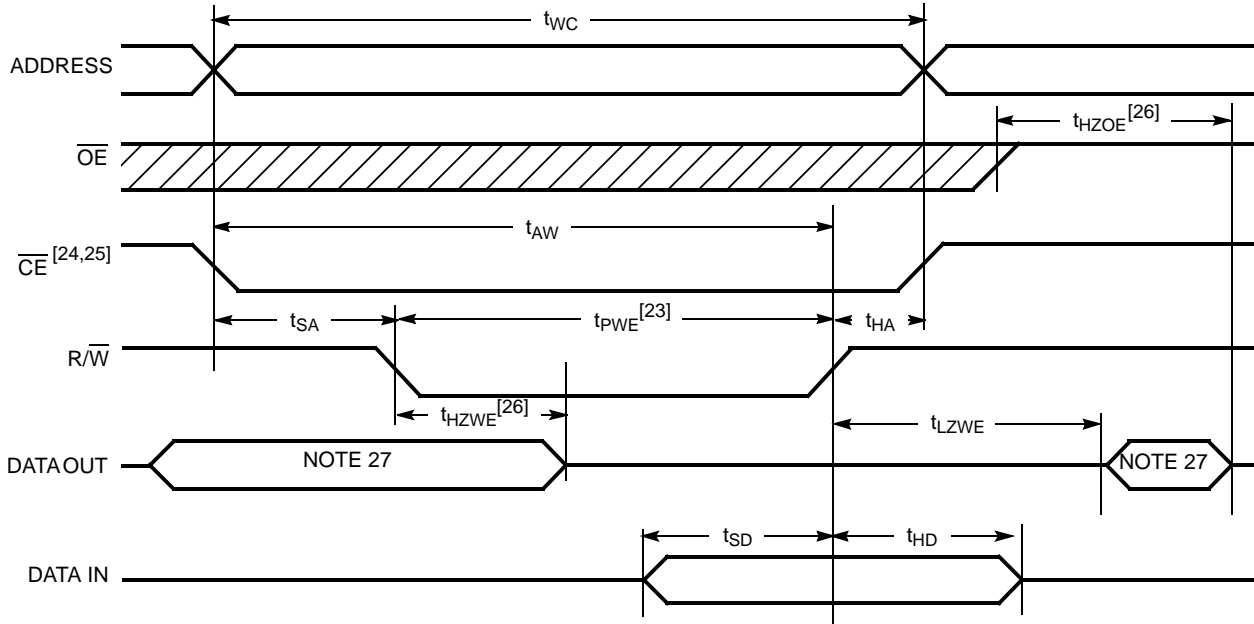
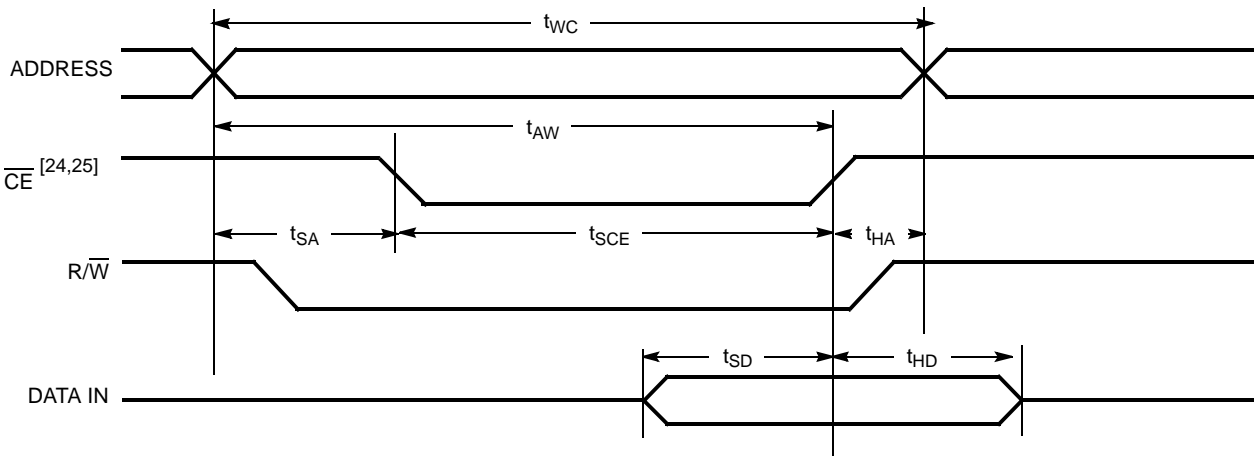

Figure 8. Write Cycle No. 2: \overline{CE} Controlled Timing^[20, 21, 22, 28]



Notes

20. $\overline{R/W}$ must be HIGH during all address transitions.
21. A write occurs during the overlap (t_{SCE} or t_{PWE}) of a LOW \overline{CE} or \overline{SEM} and a LOW \overline{UB} or \overline{LB} .
22. t_{HA} is measured from the earlier of \overline{CE} or $\overline{R/W}$ or (\overline{SEM} or $\overline{R/W}$) going HIGH at the end of write cycle.
23. If \overline{OE} is LOW during a $\overline{R/W}$ controlled write cycle, the write pulse width must be the larger of t_{PWE} or ($t_{HZWE} + t_{SD}$) to allow the I/O drivers to turn off and data to be placed on the bus for the required t_{SD} . If \overline{OE} is HIGH during an $\overline{R/W}$ controlled write cycle, this requirement does not apply and the write pulse can be as short as the specified t_{PWE} .
24. To access RAM, $\overline{CE} = V_{IL}$, $\overline{SEM} = V_{IH}$.
25. To access upper byte, $\overline{CE} = V_{IL}$, $\overline{UB} = V_{IL}$, $\overline{SEM} = V_{IH}$.
To access lower byte, $\overline{CE} = V_{IL}$, $\overline{LB} = V_{IL}$, $\overline{SEM} = V_{IH}$.
26. Transition is measured ± 500 mV from steady state with a 5 pF load (including scope and jig). This parameter is sampled and not 100% tested.
27. During this period, the I/O pins are in the output state, and input signals must not be applied.
28. If the \overline{CE} or \overline{SEM} LOW transition occurs simultaneously with or after the $\overline{R/W}$ LOW transition, the outputs remain in the high impedance state.

Switching Waveforms(continued)

Figure 9. Semaphore Read After Write Timing, Either Side^[29]

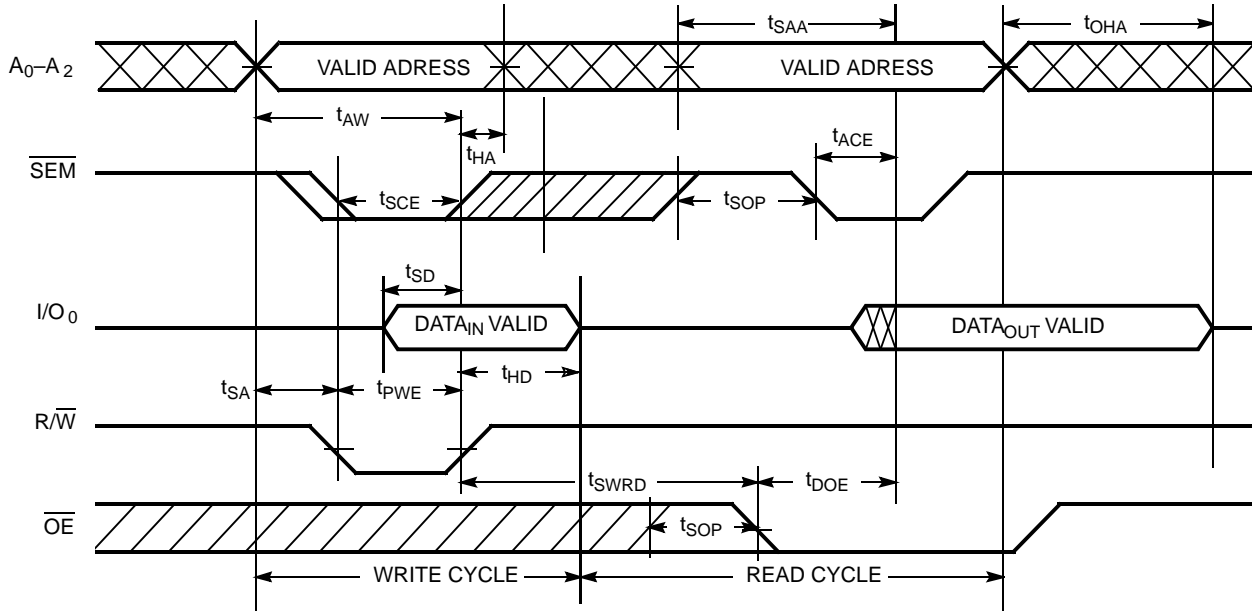
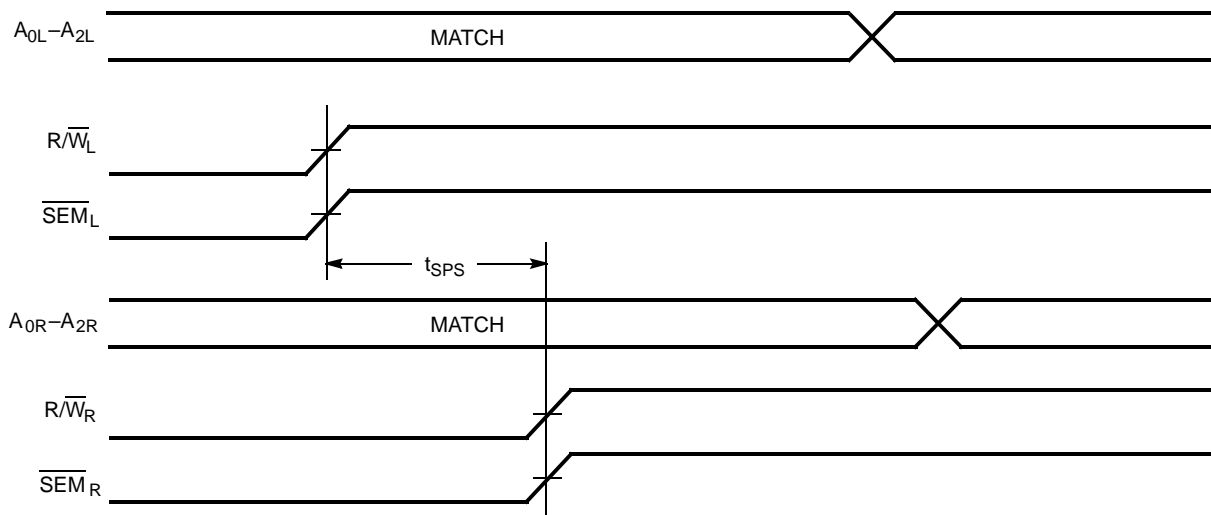

Figure 10. Timing Diagram of Semaphore Contention^[30, 31, 32]



Notes

29. CE = HIGH for the duration of the above timing (both write and read cycle).
30. I/O_{0R} = I/O_{0L} = LOW (request semaphore); CE_R = CE_L = HIGH.
31. Semaphores are reset (available to both ports) at cycle start.
32. If t_{SPS} is violated, the semaphore is definitely obtained by one side or the other, but which side gets the semaphore is unpredictable.

Switching Waveforms(continued)

Figure 11. Timing Diagram of Read with $\overline{\text{BUSY}}$ ($\overline{\text{M}}/\overline{\text{S}}=\text{HIGH}$)^[33]

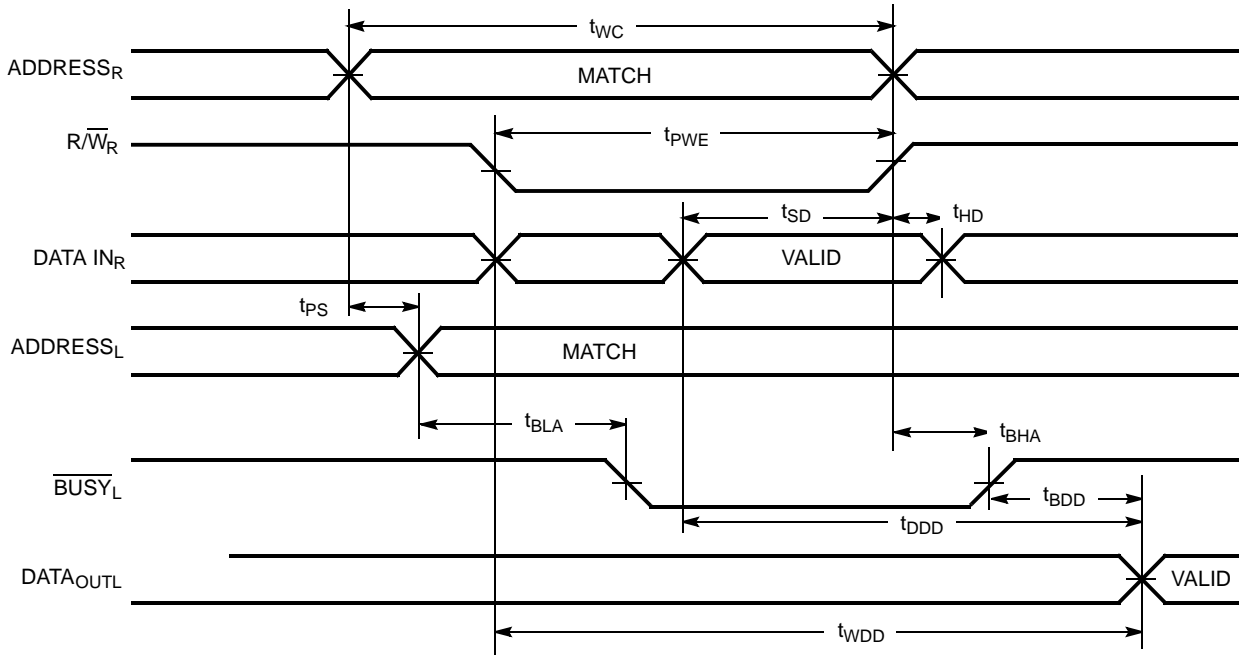
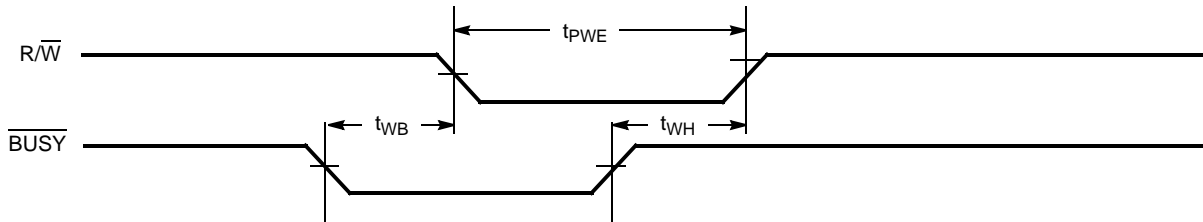

Figure 12. Write Timing with Busy Input ($\overline{\text{M}}/\overline{\text{S}}=\text{LOW}$)



Note
33. $\overline{\text{CE}}_L = \overline{\text{CE}}_R = \text{LOW}$.

Switching Waveforms(continued)

Figure 13. Busy Timing Diagram No. 1 ($\overline{\text{CE}}$ Arbitration)^[34]

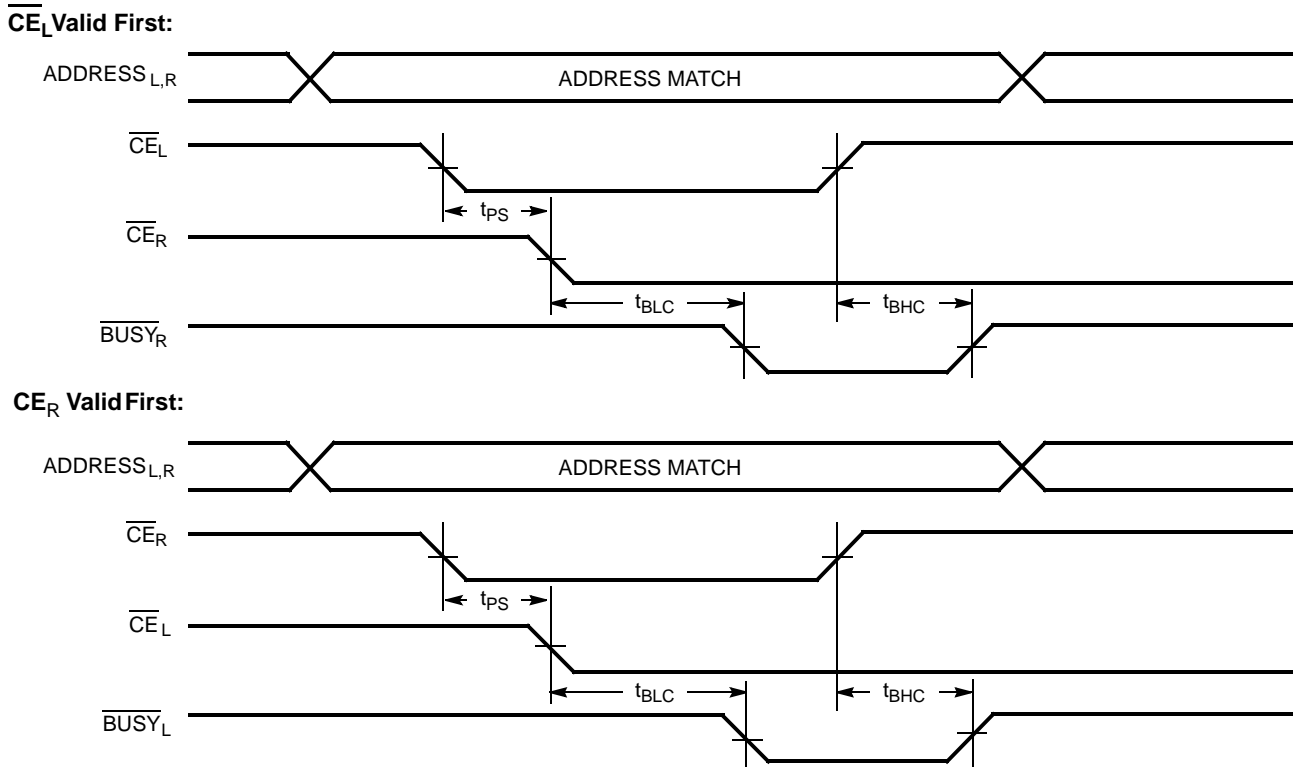
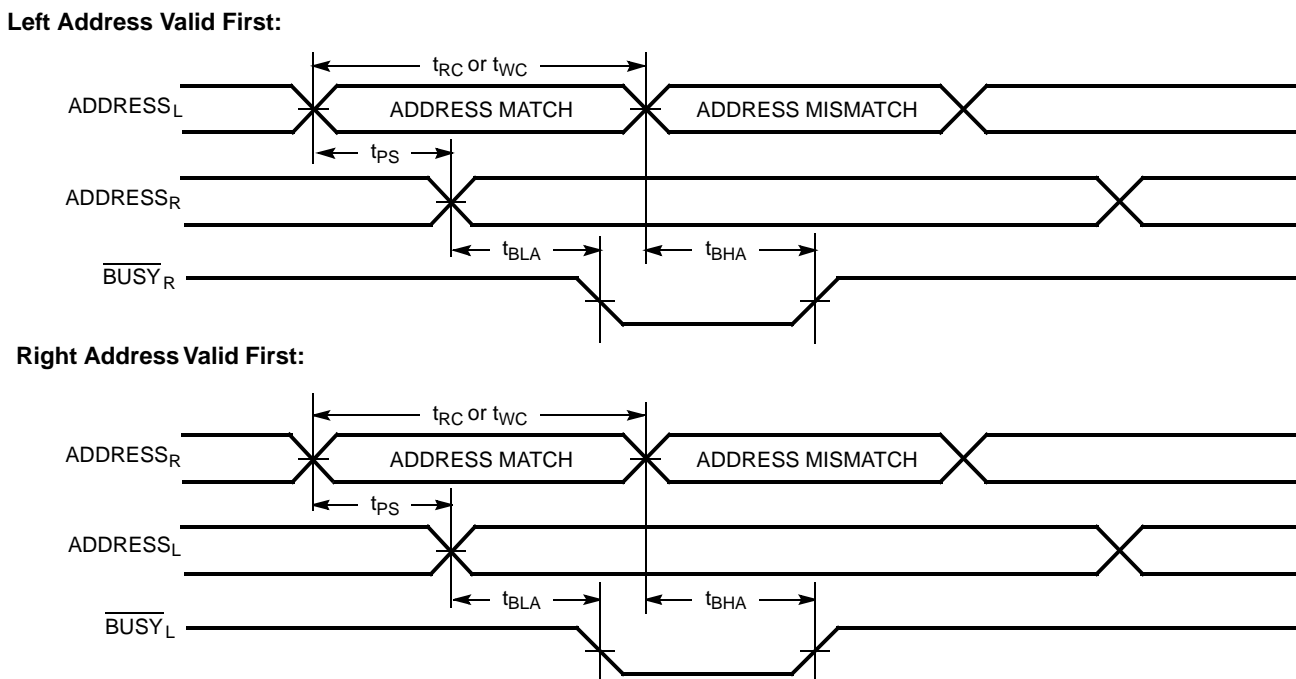

Figure 14. Busy Timing Diagram No. 2 (Address Arbitration)^[34]



Note

34. If t_{PS} is violated, the busy signal is asserted on one side or the other, but there is no guarantee to which side $\overline{\text{BUSY}}$ is asserted.

Switching Waveforms(continued)

Figure 15. Interrupt Timing Diagrams

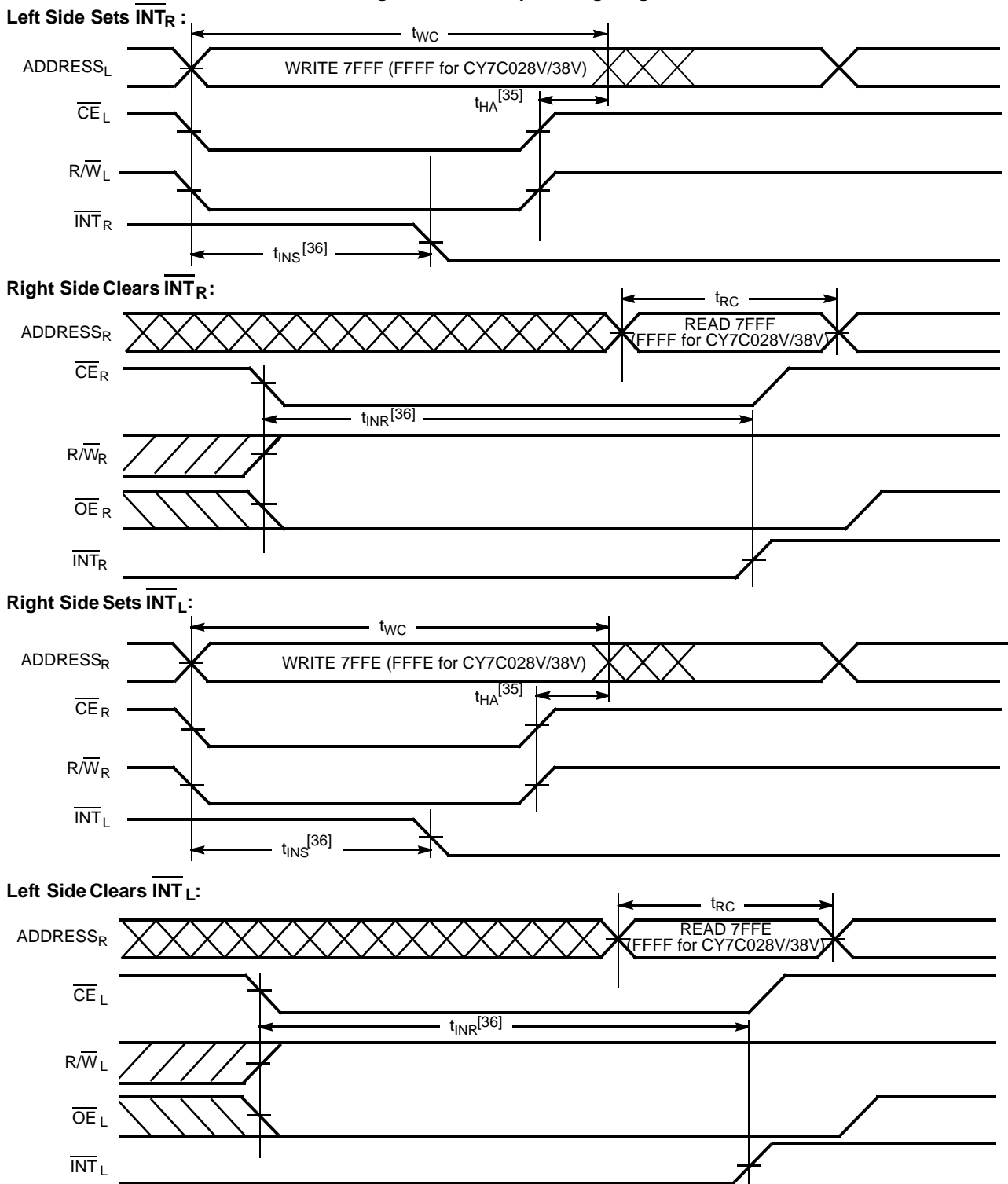

Notes

- 35. t_{HA} depends on which enable pin (\overline{CE}_L or R/\overline{W}_L) is deasserted first.
- 36. t_{INS} or t_{INR} depends on which enable pin (\overline{CE}_L or R/\overline{W}_L) is asserted last.

Table 1. Non-Contending Read/Write



Inputs						Outputs		Operation
CE	R/W	OE	UB	LB	SEM	I/O ₉ -I/O ₁₇	I/O ₀ -I/O ₈	
H	X	X	X	X	H	High Z	High Z	Deselected: Power Down
X	X	X	H	H	H	High Z	High Z	Deselected: Power Down
L	L	X	L	H	H	Data In	High Z	Write to Upper Byte Only
L	L	X	H	L	H	High Z	Data In	Write to Lower Byte Only
L	L	X	L	L	H	Data In	Data In	Write to Both Bytes
L	H	L	L	H	H	Data Out	High Z	Read Upper Byte Only
L	H	L	H	L	H	High Z	Data Out	Read Lower Byte Only
L	H	L	L	L	H	Data Out	Data Out	Read Both Bytes
X	X	H	X	X	X	High Z	High Z	Outputs Disabled
H	H	L	X	X	L	Data Out	Data Out	Read Data in Semaphore Flag
X	H	L	H	H	L	Data Out	Data Out	Read Data in Semaphore Flag
H		X	X	X	L	Data In	Data In	Write D _{IN0} into Semaphore Flag
X		X	H	H	L	Data In	Data In	Write D _{IN0} into Semaphore Flag
L	X	X	L	X	L			Not Allowed
L	X	X	X	L	L			Not Allowed

Table 2. Interrupt Operation Example (assumes $\overline{\text{BUSY}}_L = \overline{\text{BUSY}}_R = \text{HIGH}$)^[37]

Function	Left Port					Right Port					
	R/W _L	CE _L	OE _L	A _{0L-14L}	INT _L	R/W _R	CE _R	OE _R	A _{0R-14R}	INT _R	
Set Right $\overline{\text{INT}}_R$ Flag	L	L	X	7FFF	X	X	X	X	X	L ^[39]	
Reset Right $\overline{\text{INT}}_R$ Flag	X	X	X	X	X	X	L	L	7FFF	H ^[38]	
Set Left $\overline{\text{INT}}_L$ Flag	X	X	X	X	L ^[38]	L	L	X	7FFE	X	
Reset Left $\overline{\text{INT}}_L$ Flag	X	L	L	7FFE	H ^[39]	X	X	X	X	X	

Table 3. Semaphore Operation Example

Function	I/O ₀ -I/O ₁₇ Left	I/O ₀ -I/O ₁₇ Right	Status
No action	1	1	Semaphore free
Left port writes 0 to semaphore	0	1	Left port has semaphore token
Right port writes 0 to semaphore	0	1	No change. Right side has no write access to semaphore
Left port writes 1 to semaphore	1	0	Right port obtains semaphore token
Left port writes 0 to semaphore	1	0	No change. Left port has no write access to semaphore
Right port writes 1 to semaphore	0	1	Left port obtains semaphore token
Left port writes 1 to semaphore	1	1	Semaphore free
Right port writes 0 to semaphore	1	0	Right port has semaphore token
Right port writes 1 to semaphore	1	1	Semaphore free
Left port writes 0 to semaphore	0	1	Left port has semaphore token
Left port writes 1 to semaphore	1	1	Semaphore free

Notes

37. A_{0L-15L} and A_{0R-15R}, FFFF/FFFE for the CY7C028V/038V.

38. If $\overline{\text{BUSY}}_R = L$, then no change.

39. If $\overline{\text{BUSY}}_L = L$, then no change.

Ordering Information

32K x16 3.3V Asynchronous Dual-Port SRAM

Speed (ns)	Ordering Code	Package Name	Package Type	Operating Range
15	CY7C027V-15AC	A100	100-Pin Thin Quad Flat Pack	Commercial
	CY7C027V-15AXC	A100	100-Pin Pb-Free Thin Quad Flat Pack	Commercial
	CY7C027VN-15AXC	A100	100-Pin Pb-Free Thin Quad Flat Pack	Commercial
20	CY7C027V-20AC	A100	100-Pin Thin Quad Flat Pack	Commercial
	CY7C027V-20AXC	A100	100-Pin Pb-Free Thin Quad Flat Pack	Commercial
25	CY7C027V-25AC	A100	100-Pin Thin Quad Flat Pack	Commercial
	CY7C027V-25AXC	A100	100-Pin Pb-Free Thin Quad Flat Pack	Commercial
	CY7C027AV-25AXI	A100	100-Pin Pb-Free Thin Quad Flat Pack	Industrial

64K x16 3.3V Asynchronous Dual-Port SRAM

Speed (ns)	Ordering Code	Package Name	Package Type	Operating Range
15	CY7C028V-15AC	A100	100-Pin Thin Quad Flat Pack	Commercial
	CY7C028V-15AXC	A100	100-Pin Pb-Free Thin Quad Flat Pack	Commercial
20	CY7C028V-20AC	A100	100-Pin Thin Quad Flat Pack	Commercial
	CY7C028V-20AXC	A100	100-Pin Pb-Free Thin Quad Flat Pack	Commercial
	CY7C028V-20AI	A100	100-Pin Thin Quad Flat Pack	Industrial
	CY7C028V-20AXI	A100	100-Pin Pb-Free Thin Quad Flat Pack	Industrial
25	CY7C028V-25AC	A100	100-Pin Thin Quad Flat Pack	Commercial
	CY7C028V-25AXC	A100	100-Pin Pb-Free Thin Quad Flat Pack	Commercial

32K x18 3.3V Asynchronous Dual-Port SRAM

Speed (ns)	Ordering Code	Package Name	Package Type	Operating Range
15	CY7C037V-15AC	A100	100-Pin Thin Quad Flat Pack	Commercial
	CY7C037V-15AXC	A100	100-Pin Pb-Free Thin Quad Flat Pack	Commercial
20	CY7C037V-20AC	A100	100-Pin Thin Quad Flat Pack	Commercial
	CY7C037AV-20AXC	A100	100-Pin Pb-Free Thin Quad Flat Pack	Commercial
25	CY7C037V-25AC	A100	100-Pin Thin Quad Flat Pack	Commercial
	CY7C037V-25AXC	A100	100-Pin Pb-Free Thin Quad Flat Pack	Commercial

64K x18 3.3V Asynchronous Dual-Port SRAM

Speed (ns)	Ordering Code	Package Name	Package Type	Operating Range
15	CY7C038V-15AC	A100	100-Pin Thin Quad Flat Pack	Commercial
	CY7C038V-15AXC	A100	100-Pin Pb-Free Thin Quad Flat Pack	Commercial
20	CY7C038V-20AC	A100	100-Pin Thin Quad Flat Pack	Commercial
	CY7C038V-20AXC	A100	100-Pin Pb-Free Thin Quad Flat Pack	Commercial
	CY7C038V-20AI	A100	100-Pin Thin Quad Flat Pack	Industrial
	CY7C038V-20AXI	A100	100-Pin Pb-Free Thin Quad Flat Pack	Industrial
25	CY7C038V-25AC	A100	100-Pin Thin Quad Flat Pack	Commercial
	CY7C038V-25AXC	A100	100-Pin Pb-Free Thin Quad Flat Pack	Commercial

Package Diagram

Figure 16. 100-Pin Pb-Free Thin Plastic Quad Flat Pack (TQFP) A100

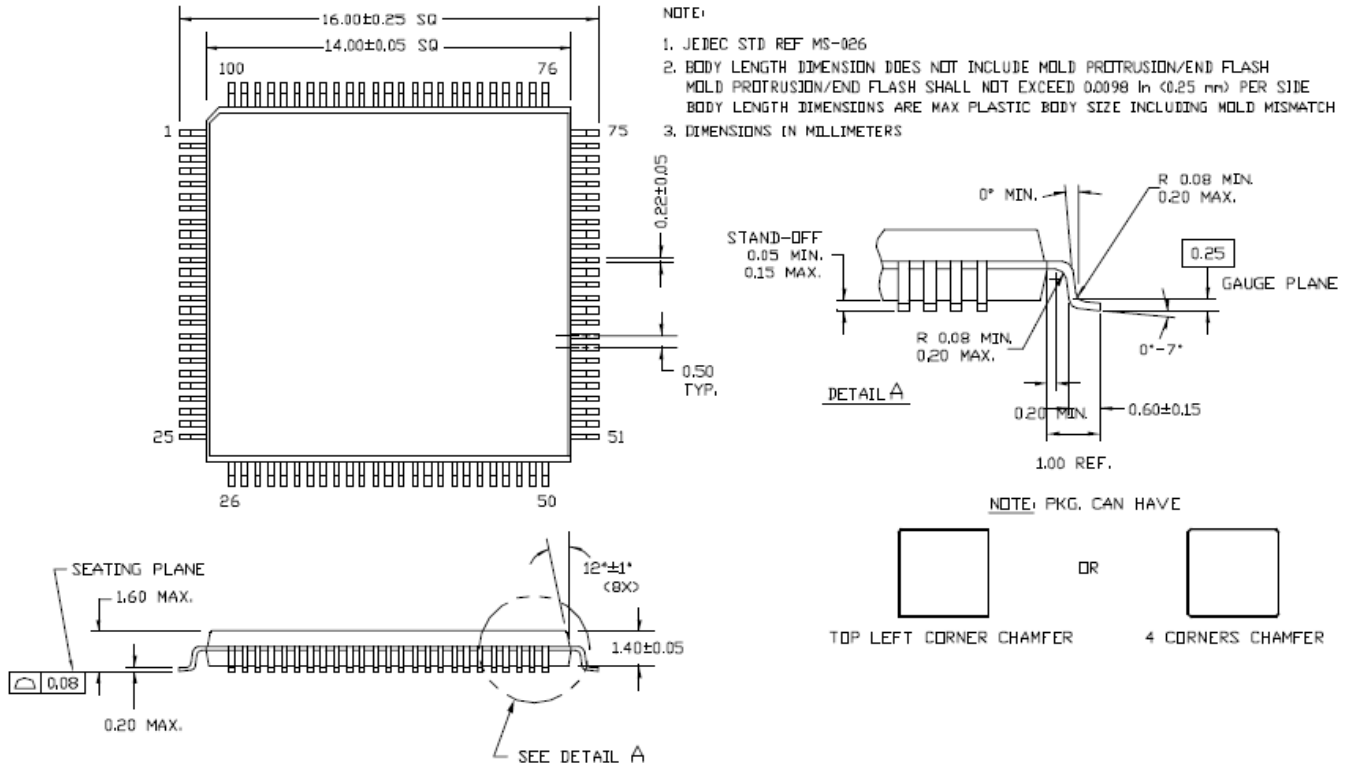

51-85048-C

Document History Page

Document Title: CY7C027V/027VN/027AV/CY7C028V/037V/037AV/038V 3.3V 32K/64K x 16/18 Dual Port Static RAM				
Document Number: 38-06078				
Rev.	ECN No.	Orig. of Change	Submission Date	Description of Change
**	237626	YDT	6/30/04	Converted data sheet from old spec 38-00670 to conform with new data sheet. Removed cross information from features section
*A	259110	JHX	See ECN	Added Pb-Free packaging information.
*B	2623540	VKN/PYRS	12/17/08	Added CY7C027VN, CY7C027AV and CY7C037AV parts Updated Ordering information table

Sales, Solutions, and Legal Information

Worldwide Sales and Design Support

Cypress maintains a worldwide network of offices, solution centers, manufacturer's representatives, and distributors. To find the office closest to you, visit us at cypress.com/sales.

Products

PSoC	psoc.cypress.com
Clocks & Buffers	clocks.cypress.com
Wireless	wireless.cypress.com
Memories	memory.cypress.com
Image Sensors	image.cypress.com

PSoC Solutions

General	psoc.cypress.com/solutions
Low Power/Low Voltage	psoc.cypress.com/low-power
Precision Analog	psoc.cypress.com/precision-analog
LCD Drive	psoc.cypress.com/lcd-drive
CAN 2.0b	psoc.cypress.com/can
USB	psoc.cypress.com/usb

© Cypress Semiconductor Corporation, 2001-2008. The information contained herein is subject to change without notice. Cypress Semiconductor Corporation assumes no responsibility for the use of any circuitry other than circuitry embodied in a Cypress product. Nor does it convey or imply any license under patent or other rights. Cypress products are not warranted nor intended to be used for medical, life support, life saving, critical control or safety applications, unless pursuant to an express written agreement with Cypress. Furthermore, Cypress does not authorize its products for use as critical components in life-support systems where a malfunction or failure may reasonably be expected to result in significant injury to the user. The inclusion of Cypress products in life-support systems application implies that the manufacturer assumes all risk of such use and in doing so indemnifies Cypress against all charges.



Any Source Code (software and/or firmware) is owned by Cypress Semiconductor Corporation (Cypress) and is protected by and subject to worldwide patent protection (United States and foreign), United States copyright laws and international treaty provisions. Cypress hereby grants to licensee a personal, non-exclusive, non-transferable license to copy, use, modify, create derivative works of, and compile the Cypress Source Code and derivative works for the sole purpose of creating custom software and or firmware in support of licensee product to be used only in conjunction with a Cypress integrated circuit as specified in the applicable agreement. Any reproduction, modification, translation, compilation, or representation of this Source Code except as specified above is prohibited without the express written permission of Cypress.

Disclaimer: CYPRESS MAKES NO WARRANTY OF ANY KIND, EXPRESS OR IMPLIED, WITH REGARD TO THIS MATERIAL, INCLUDING, BUT NOT LIMITED TO, THE IMPLIED WARRANTIES OF MERCHANTABILITY AND FITNESS FOR A PARTICULAR PURPOSE. Cypress reserves the right to make changes without further notice to the materials described herein. Cypress does not assume any liability arising out of the application or use of any product or circuit described herein. Cypress does not authorize its products for use as critical components in life-support systems where a malfunction or failure may reasonably be expected to result in significant injury to the user. The inclusion of Cypress' product in a life-support systems application implies that the manufacturer assumes all risk of such use and in doing so indemnifies Cypress against all charges.

Use may be limited by and subject to the applicable Cypress software license agreement.

Looking for pricing, stock, or lifecycle information?

Click below to explore more details on WIN SOURCE:

-  [View CY7C037V-15AC on WIN SOURCE](#)
-  [Cypress Semiconductor Corp Information](#)

Optimize Your Supply Chain with WIN SOURCE Solutions

-  Global Sourcing Solution
-  Obsolete Management
-  Cost Control Management
-  Shortage Management
-  Alternative Solution
-  Excess Inventory Management