



**THE DATASHEET OF
CY74FCT821CTQCT**



CY74FCT821T

10-BIT BUS-INTERFACE REGISTER WITH 3-STATE OUTPUTS

SCCS033B– MAY 1994 – REVISED NOVEMBER 2001

- **Function, Pinout, and Drive Compatible With FCT, F Logic, and AM29821**
- **Reduced V_{OH} (Typically = 3.3 V) Version of Equivalent FCT Functions**
- **Edge-Rate Control Circuitry for Significantly Improved Noise Characteristics**
- **I_{off} Supports Partial-Power-Down Mode Operation**
- **Matched Rise and Fall Times**
- **Fully Compatible With TTL Input and Output Logic Levels**
- **ESD Protection Exceeds JESD 22**
 - 2000-V Human-Body Model (A114-A)
 - 200-V Machine Model (A115-A)
 - 1000-V Charged-Device Model (C101)
- **64-mA Output Sink Current**
32-mA Output Source Current
- **High-Speed Parallel Register With Positive-Edge-Triggered D-Type Flip-Flops**
- **3-State Outputs**

P, Q, OR SO PACKAGE
(TOP VIEW)

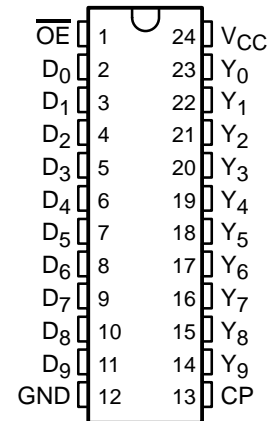

description

This bus-interface register is designed to eliminate the extra packages required to buffer existing registers and provide extra data width for wider address/data paths or buses carrying parity. The CY74FCT821T is a 10-bit-wide buffered version of the popular CY74FCT374 function. This device is ideal for use as an output port requiring high I_{OL}/I_{OH} .

This device is designed for high-capacitance load drive capability, while providing low-capacitance bus loading at both inputs and outputs. Outputs are designed for low-capacitance bus loading in the high-impedance state.

This device is fully specified for partial-power-down applications using I_{off} . The I_{off} circuitry disables the outputs, preventing damaging current backflow through the device when it is powered down.

PIN DESCRIPTION

NAME	I/O	DESCRIPTION
D	I	D flip-flop data inputs
CP	O	Clock pulse for the register. Enters data into the register on the low-to-high clock transition.
Y	O	Register 3-state outputs
\overline{OE}	I	Output control. When \overline{OE} is high, the Y outputs are in the high-impedance state. When \overline{OE} is low, true register data is present at the Y outputs.



Please be aware that an important notice concerning availability, standard warranty, and use in critical applications of Texas Instruments semiconductor products and disclaimers thereto appears at the end of this data sheet.

PRODUCTION DATA information is current as of publication date. Products conform to specifications per the terms of Texas Instruments standard warranty. Production processing does not necessarily include testing of all parameters.



POST OFFICE BOX 655303 • DALLAS, TEXAS 75265

Copyright © 2001, Texas Instruments Incorporated

CY74FCT821T

10-BIT BUS-INTERFACE REGISTER

WITH 3-STATE OUTPUTS

SCCS033B—MAY 1994—REVISED NOVEMBER 2001

ORDERING INFORMATION

TA	PACKAGE†		SPEED (ns)	ORDERABLE PART NUMBER	TOP-SIDE MARKING
-40°C to 85°C	QSOP – Q	Tape and reel	6	CY74FCT821CTQCT	FCT821C
	SOIC – SO	Tube	6	CY74FCT821CTSOC	FCT821C
		Tape and reel	6	CY74FCT821CTSUCT	
	DIP – P	Tube	7.5	CY74FCT821BTPC	CY74FCT821BTPC
	SOIC – SO	Tube	7.5	CY74FCT821BTSOC	FCT821B
		Tape and reel	7.5	CY74FCT821BTSUCT	
	QSOP – Q	Tape and reel	10	CY74FCT821ATQCT	FCT821A
	SOIC – SO	Tube	10	CY74FCT821ATSOC	FCT821A
Tape and reel		10	CY74FCT821ATSUCT		

† Package drawings, standard packing quantities, thermal data, symbolization, and PCB design guidelines are available at www.ti.com/sc/package.

FUNCTION TABLE

INPUTS			INTERNAL OUTPUTS		FUNCTION
\overline{OE}	D	CP	Q	Y	
H	X	↑	L	Z	Z
H	L	↑	L	Z	Load
H	H	↑	H	Z	
L	L	↑	L	L	
L	H	↑	H	H	

H = High logic level, L = Low logic level, X = Don't care, ↑ = Low-to-high transition, Z = High-impedance state

logic diagram (positive logic)

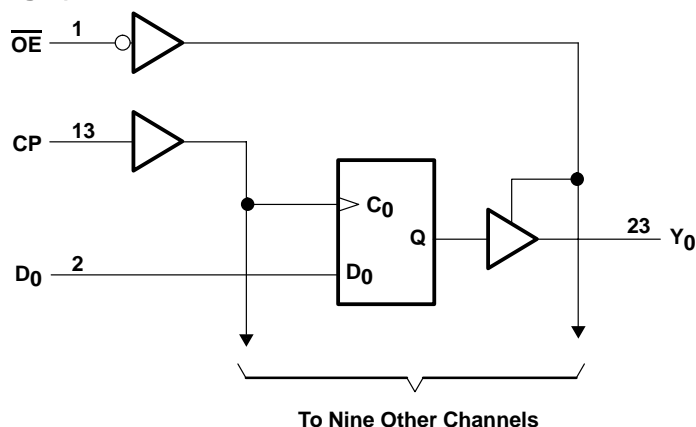

CY74FCT821T

10-BIT BUS-INTERFACE REGISTER

WITH 3-STATE OUTPUTS

SCCS033B—MAY 1994—REVISED NOVEMBER 2001

electrical characteristics over recommended operating free-air temperature range (unless otherwise noted)

PARAMETER	TEST CONDITIONS		MIN	TYP†	MAX	UNIT	
V_{IK}	$V_{CC} = 4.75\text{ V}$,	$I_{IN} = -18\text{ mA}$		-0.7	-1.2	V	
V_{OH}	$V_{CC} = 4.75\text{ V}$	$I_{OH} = -32\text{ mA}$		2		V	
		$I_{OH} = -15\text{ mA}$	2.4	3.3			
V_{OL}	$V_{CC} = 4.75\text{ V}$,	$I_{OL} = 64\text{ mA}$		0.3	0.55	V	
V_{hys}	All inputs			0.2		V	
I_I	$V_{CC} = 5.25\text{ V}$,	$V_{IN} = V_{CC}$			5	μA	
I_{IH}	$V_{CC} = 5.25\text{ V}$,	$V_{IN} = 2.7\text{ V}$			± 1	μA	
I_{IL}	$V_{CC} = 5.25\text{ V}$,	$V_{IN} = 0.5\text{ V}$			± 1	μA	
I_{OZH}	$V_{CC} = 5.25\text{ V}$,	$V_{OUT} = 2.7\text{ V}$			10	μA	
I_{OZL}	$V_{CC} = 5.25\text{ V}$,	$V_{OUT} = 0.5\text{ V}$			-10	μA	
I_{OS}^\ddagger	$V_{CC} = 5.25\text{ V}$,	$V_{OUT} = 0\text{ V}$	-60	-120	-225	mA	
I_{off}	$V_{CC} = 0\text{ V}$,	$V_{OUT} = 4.5\text{ V}$			± 1	μA	
I_{CC}	$V_{CC} = 5.25\text{ V}$,	$V_{IN} \leq 0.2\text{ V}$, $V_{IN} \geq V_{CC} - 0.2\text{ V}$		0.1	0.2	mA	
ΔI_{CC}	$V_{CC} = 5.25\text{ V}$, $V_{IN} = 3.4\text{ V}^\S$, $f_1 = 0$, Outputs open			0.5	2	mA	
I_{CCD}^\parallel	$V_{CC} = 5.25\text{ V}$, One bit switching at 50% duty cycle, Outputs open, $OE = EN = \text{GND}$, $V_{IN} \leq 0.2\text{ V}$ or $V_{IN} \geq V_{CC} - 0.2\text{ V}$			0.06	0.12	mA/MHz	
$I_{C\#}$	$V_{CC} = 5.25\text{ V}$, Outputs open, $OE = EN = \text{GND}$	One bit switching at $f_1 = 5\text{ MHz}$ at 50% duty cycle	$V_{IN} \leq 0.2\text{ V}$ or $V_{IN} \geq V_{CC} - 0.2\text{ V}$		0.7	1.4	mA
			$V_{IN} = 3.4\text{ V}$ or GND		1.2	3.4	
		Eight bits switching at $f_1 = 2.5\text{ MHz}$ at 50% duty cycle	$V_{IN} \leq 0.2\text{ V}$ or $V_{IN} \geq V_{CC} - 0.2\text{ V}$		1.6	3.2	
			$V_{IN} = 3.4\text{ V}$ or GND		3.9	12.2	
C_i				5	10	pF	
C_o				9	12	pF	

† Typical values are at $V_{CC} = 5\text{ V}$, $T_A = 25^\circ\text{C}$.

‡ Not more than one output should be shorted at a time. Duration of short should not exceed one second. The use of high-speed test apparatus and/or sample-and-hold techniques are preferable to minimize internal chip heating and more accurately reflect operational values. Otherwise, prolonged shorting of a high output can raise the chip temperature well above normal and cause invalid readings in other parametric tests. In any sequence of parameter tests, I_{OS} tests should be performed last.

§ Per TTL-driven input ($V_{IN} = 3.4\text{ V}$); all other inputs at V_{CC} or GND

¶ This parameter is derived for use in total power-supply calculations.

$I_C = I_{CC} + \Delta I_{CC} \times D_H \times N_T + I_{CCD} (f_0/2 + f_1 \times N_1)$

Where:

I_C = Total supply current

I_{CC} = Power-supply current with CMOS input levels

ΔI_{CC} = Power-supply current for a TTL high input ($V_{IN} = 3.4\text{ V}$)

D_H = Duty cycle for TTL inputs high

N_T = Number of TTL inputs at D_H

I_{CCD} = Dynamic current caused by an input transition pair (HLH or LHL)

f_0 = Clock frequency for registered devices, otherwise zero

f_1 = Input signal frequency

N_1 = Number of inputs changing at f_1

All currents are in milliamperes and all frequencies are in megahertz.

|| Values for these conditions are examples of the I_{CC} formula.



CY74FCT821T
10-BIT BUS-INTERFACE REGISTER
WITH 3-STATE OUTPUTS

SCCS033B– MAY 1994 – REVISED NOVEMBER 2001

timing requirements over recommended operating free-air temperature range (unless otherwise noted) (see Figure 1)

PARAMETER			TEST LOAD	CY74FCT821AT		CY74FCT821BT		CY74FCT821CT		UNIT
				MIN	MAX	MIN	MAX	MIN	MAX	
t_w	Pulse duration	CP	$C_L = 50 \text{ pF}$, $R_L = 500 \Omega$	7		6		6		ns
t_{su}	Setup time, before CP \uparrow	Data	$C_L = 50 \text{ pF}$, $R_L = 500 \Omega$	4		3		3		ns
t_h	Hold time, after CP \uparrow	Data	$C_L = 50 \text{ pF}$, $R_L = 500 \Omega$	2		1.5		1.5		ns

switching characteristics over operating free-air temperature range (see Figure 1)

PARAMETER	FROM (INPUT)	TO (OUTPUT)	TEST LOAD	CY74FCT821AT		CY74FCT821BT		CY74FCT821CT		UNIT
				MIN	MAX	MIN	MAX	MIN	MAX	
t_{PLH}	CP	Y	$C_L = 50 \text{ pF}$, $R_L = 500 \Omega$	10		7.5		6		ns
t_{PHL}				10		7.5		6		
t_{PLH}	CP	Y	$C_L = 300 \text{ pF}$, $R_L = 500 \Omega$	20		15		12.5		ns
t_{PHL}				20		15		12.5		
t_{PZH}	\overline{OE}	Y	$C_L = 50 \text{ pF}$, $R_L = 500 \Omega$	12		8		7		ns
t_{PZL}				12		8		7		
t_{PZH}	\overline{OE}	Y	$C_L = 300 \text{ pF}$, $R_L = 500 \Omega$	23		15		12.5		ns
t_{PZL}				23		15		12.5		
t_{PHZ}	\overline{OE}	Y	$C_L = 5 \text{ pF}$, $R_L = 500 \Omega$	7		6.5		6		ns
t_{PLZ}				7		6.5		6		
t_{PHZ}	\overline{OE}	Y	$C_L = 50 \text{ pF}$, $R_L = 500 \Omega$	8		7.5		6.5		ns
t_{PLZ}				8		7.5		6.5		

CY74FCT821T
10-BIT BUS-INTERFACE REGISTER
WITH 3-STATE OUTPUTS

SCCS033B—MAY 1994—REVISED NOVEMBER 2001

PARAMETER MEASUREMENT INFORMATION

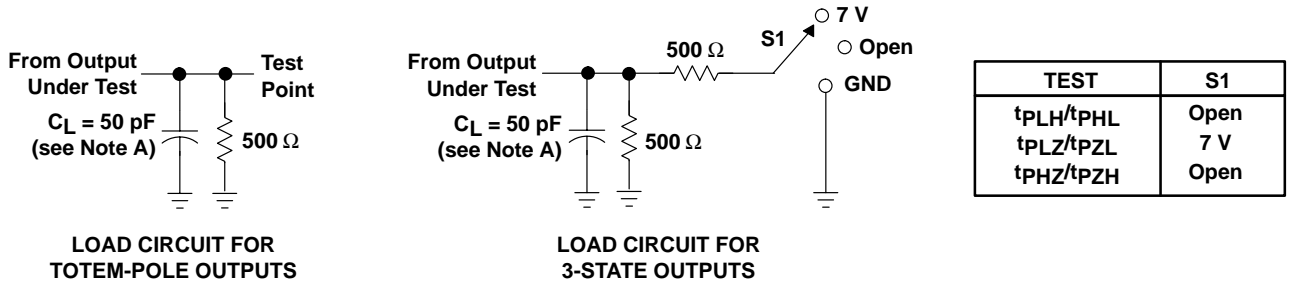

LOAD CIRCUIT FOR TOTEM-POLE OUTPUTS

LOAD CIRCUIT FOR 3-STATE OUTPUTS

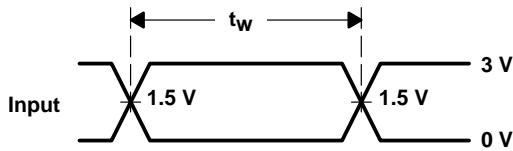

VOLTAGE WAVEFORMS PULSE DURATION

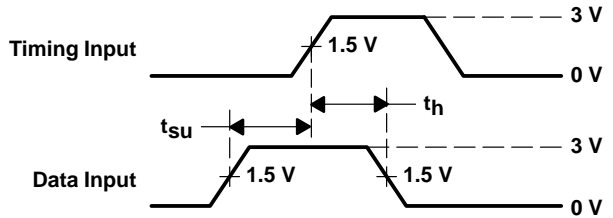

VOLTAGE WAVEFORMS SETUP AND HOLD TIMES

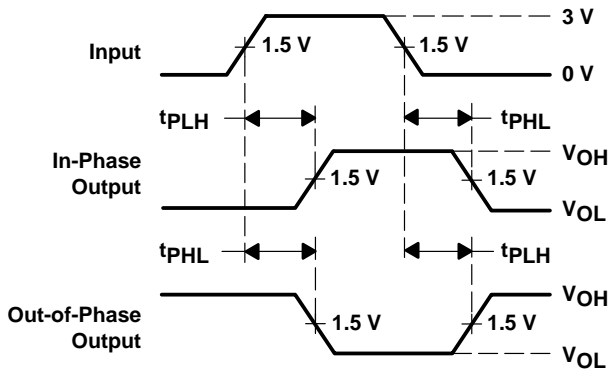

VOLTAGE WAVEFORMS PROPAGATION DELAY TIMES INVERTING AND NONINVERTING OUTPUTS

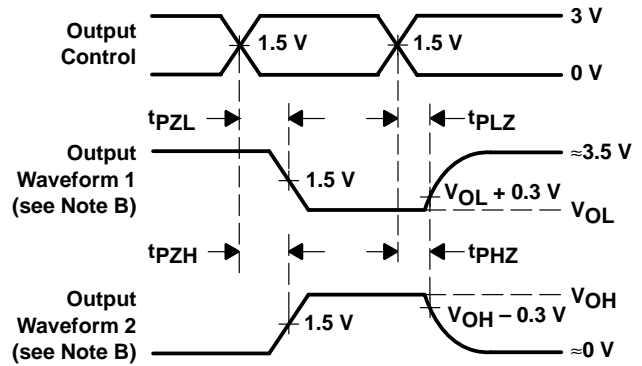

VOLTAGE WAVEFORMS ENABLE AND DISABLE TIMES LOW- AND HIGH-LEVEL ENABLING

- NOTES: A. C_L includes probe and jig capacitance.
 B. Waveform 1 is for an output with internal conditions such that the output is low except when disabled by the output control. Waveform 2 is for an output with internal conditions such that the output is high except when disabled by the output control.
 C. The outputs are measured one at a time with one input transition per measurement.

Figure 1. Load Circuit and Voltage Waveforms

PACKAGING INFORMATION

Orderable Device	Status (1)	Package Type	Package Drawing	Pins	Package Qty	Eco Plan (2)	Lead/Ball Finish (6)	MSL Peak Temp (3)	Op Temp (°C)	Device Marking (4/5)	Samples
CY74FCT821ATSOC	ACTIVE	SOIC	DW	24	25	Green (RoHS & no Sb/Br)	CU NIPDAU	Level-1-260C-UNLIM	-40 to 85	FCT821A	Samples
CY74FCT821BTSOC	ACTIVE	SOIC	DW	24	25	Green (RoHS & no Sb/Br)	CU NIPDAU	Level-1-260C-UNLIM	-40 to 85	FCT821B	Samples
CY74FCT821BTSOCE4	ACTIVE	SOIC	DW	24	25	Green (RoHS & no Sb/Br)	CU NIPDAU	Level-1-260C-UNLIM	-40 to 85	FCT821B	Samples
CY74FCT821CTQCT	ACTIVE	SSOP	DBQ	24	2500	Green (RoHS & no Sb/Br)	CU NIPDAU	Level-2-260C-1 YEAR	-40 to 85	FCT821C	Samples
CY74FCT821CTSOC	ACTIVE	SOIC	DW	24	25	Green (RoHS & no Sb/Br)	CU NIPDAU	Level-1-260C-UNLIM	-40 to 85	FCT821C	Samples
CY74FCT821CTSOCT	ACTIVE	SOIC	DW	24	2000	Green (RoHS & no Sb/Br)	CU NIPDAU	Level-1-260C-UNLIM	-40 to 85	FCT821C	Samples

(1) The marketing status values are defined as follows:

ACTIVE: Product device recommended for new designs.

LIFEBUY: TI has announced that the device will be discontinued, and a lifetime-buy period is in effect.

NRND: Not recommended for new designs. Device is in production to support existing customers, but TI does not recommend using this part in a new design.

PREVIEW: Device has been announced but is not in production. Samples may or may not be available.

OBSELETE: TI has discontinued the production of the device.

(2) **RoHS:** TI defines "RoHS" to mean semiconductor products that are compliant with the current EU RoHS requirements for all 10 RoHS substances, including the requirement that RoHS substance do not exceed 0.1% by weight in homogeneous materials. Where designed to be soldered at high temperatures, "RoHS" products are suitable for use in specified lead-free processes. TI may reference these types of products as "Pb-Free".

RoHS Exempt: TI defines "RoHS Exempt" to mean products that contain lead but are compliant with EU RoHS pursuant to a specific EU RoHS exemption.

Green: TI defines "Green" to mean the content of Chlorine (Cl) and Bromine (Br) based flame retardants meet JS709B low halogen requirements of <=1000ppm threshold. Antimony trioxide based flame retardants must also meet the <=1000ppm threshold requirement.

(3) MSL, Peak Temp. - The Moisture Sensitivity Level rating according to the JEDEC industry standard classifications, and peak solder temperature.

(4) There may be additional marking, which relates to the logo, the lot trace code information, or the environmental category on the device.

(5) Multiple Device Markings will be inside parentheses. Only one Device Marking contained in parentheses and separated by a "~" will appear on a device. If a line is indented then it is a continuation of the previous line and the two combined represent the entire Device Marking for that device.

⁽⁶⁾ Lead/Ball Finish - Orderable Devices may have multiple material finish options. Finish options are separated by a vertical ruled line. Lead/Ball Finish values may wrap to two lines if the finish value exceeds the maximum column width.

Important Information and Disclaimer:The information provided on this page represents TI's knowledge and belief as of the date that it is provided. TI bases its knowledge and belief on information provided by third parties, and makes no representation or warranty as to the accuracy of such information. Efforts are underway to better integrate information from third parties. TI has taken and continues to take reasonable steps to provide representative and accurate information but may not have conducted destructive testing or chemical analysis on incoming materials and chemicals. TI and TI suppliers consider certain information to be proprietary, and thus CAS numbers and other limited information may not be available for release.

In no event shall TI's liability arising out of such information exceed the total purchase price of the TI part(s) at issue in this document sold by TI to Customer on an annual basis.

TAPE AND REEL INFORMATION

QUADRANT ASSIGNMENTS FOR PIN 1 ORIENTATION IN TAPE

*All dimensions are nominal

Device	Package Type	Package Drawing	Pins	SPQ	Reel Diameter (mm)	Reel Width W1 (mm)	A0 (mm)	B0 (mm)	K0 (mm)	P1 (mm)	W (mm)	Pin1 Quadrant
CY74FCT821CTQCT	SSOP	DBQ	24	2500	330.0	16.4	6.5	9.0	2.1	8.0	16.0	Q1
CY74FCT821CTSOCT	SOIC	DW	24	2000	330.0	24.4	10.75	15.7	2.7	12.0	24.0	Q1

TAPE AND REEL BOX DIMENSIONS

*All dimensions are nominal

Device	Package Type	Package Drawing	Pins	SPQ	Length (mm)	Width (mm)	Height (mm)
CY74FCT821CTQCT	SSOP	DBQ	24	2500	367.0	367.0	38.0
CY74FCT821CTSOCT	SOIC	DW	24	2000	350.0	350.0	43.0

DW (R-PDSO-G24)

PLASTIC SMALL OUTLINE



- NOTES:
- A. All linear dimensions are in inches (millimeters). Dimensioning and tolerancing per ASME Y14.5M-1994.
 - B. This drawing is subject to change without notice.
 - C. Body dimensions do not include mold flash or protrusion not to exceed 0.006 (0,15).
 - D. Falls within JEDEC MS-013 variation AD.

DBQ (R-PDSO-G24)

PLASTIC SMALL OUTLINE PACKAGE

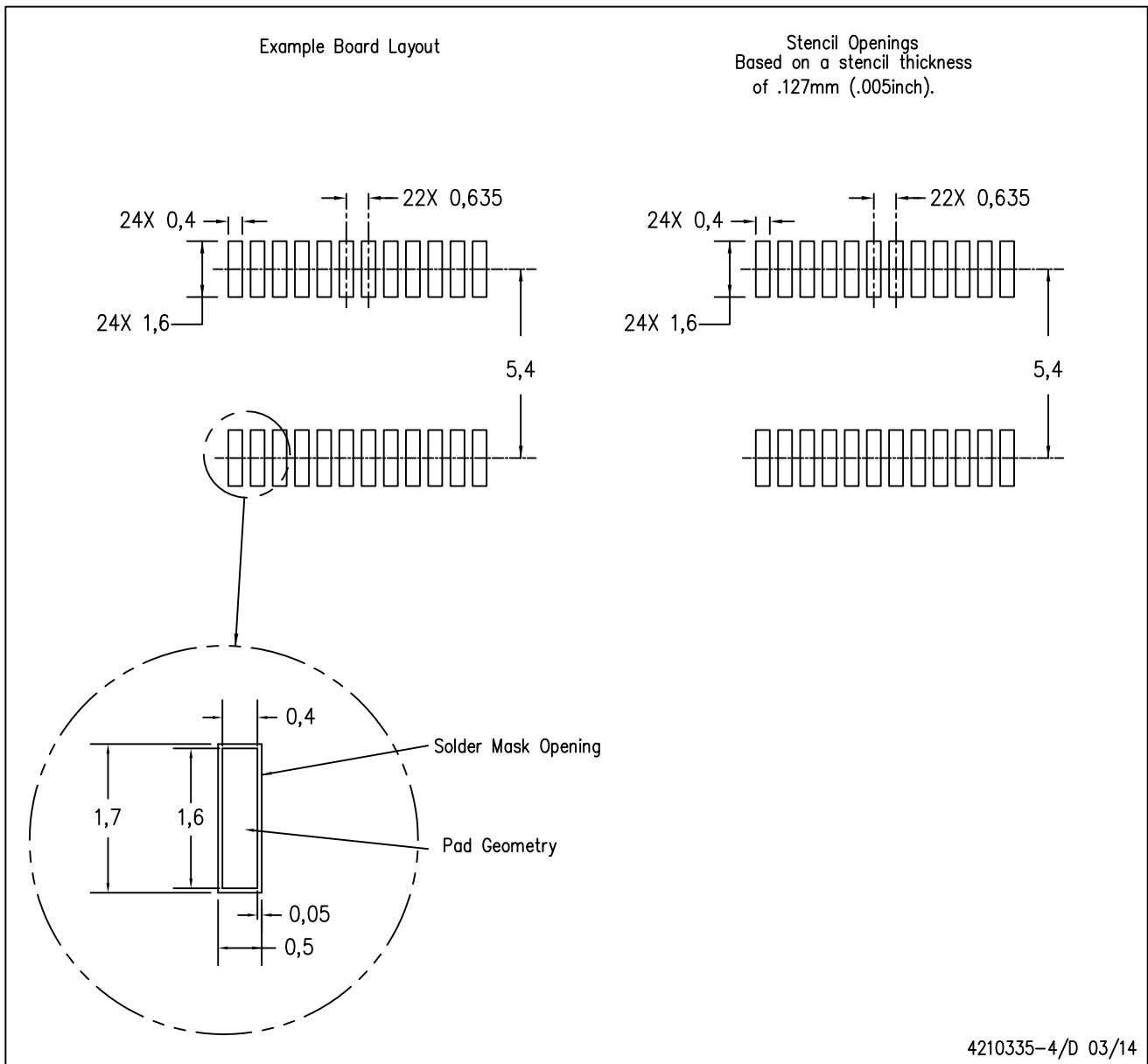

- NOTES:
- A. All linear dimensions are in millimeters.
 - B. This drawing is subject to change without notice.
 - C. Publication IPC-7351 is recommended for alternate designs.
 - D. Laser cutting apertures with trapezoidal walls and also rounding corners will offer better paste release. Customers should contact their board assembly site for stencil design recommendations. Example stencil design based on a 50% volumetric metal load solder paste. Refer to IPC-7525 for other stencil recommendations.

IMPORTANT NOTICE AND DISCLAIMER

TI PROVIDES TECHNICAL AND RELIABILITY DATA (INCLUDING DATASHEETS), DESIGN RESOURCES (INCLUDING REFERENCE DESIGNS), APPLICATION OR OTHER DESIGN ADVICE, WEB TOOLS, SAFETY INFORMATION, AND OTHER RESOURCES "AS IS" AND WITH ALL FAULTS, AND DISCLAIMS ALL WARRANTIES, EXPRESS AND IMPLIED, INCLUDING WITHOUT LIMITATION ANY IMPLIED WARRANTIES OF MERCHANTABILITY, FITNESS FOR A PARTICULAR PURPOSE OR NON-INFRINGEMENT OF THIRD PARTY INTELLECTUAL PROPERTY RIGHTS.

These resources are intended for skilled developers designing with TI products. You are solely responsible for (1) selecting the appropriate TI products for your application, (2) designing, validating and testing your application, and (3) ensuring your application meets applicable standards, and any other safety, security, or other requirements. These resources are subject to change without notice. TI grants you permission to use these resources only for development of an application that uses the TI products described in the resource. Other reproduction and display of these resources is prohibited. No license is granted to any other TI intellectual property right or to any third party intellectual property right. TI disclaims responsibility for, and you will fully indemnify TI and its representatives against, any claims, damages, costs, losses, and liabilities arising out of your use of these resources.

TI's products are provided subject to TI's Terms of Sale (www.ti.com/legal/termsofsale.html) or other applicable terms available either on ti.com or provided in conjunction with such TI products. TI's provision of these resources does not expand or otherwise alter TI's applicable warranties or warranty disclaimers for TI products.

Mailing Address: Texas Instruments, Post Office Box 655303, Dallas, Texas 75265
Copyright © 2019, Texas Instruments Incorporated

Looking for pricing, stock, or lifecycle information?

Click below to explore more details on WIN SOURCE:

 [View CY74FCT821CTQCT on WIN SOURCE](#)

 [Texas Instruments](#) Information

Optimize Your Supply Chain with WIN SOURCE Solutions

-  Global Sourcing Solution
-  Obsolete Management
-  Cost Control Management
-  Shortage Management
-  Alternative Solution
-  Excess Inventory Management