



**THE DATASHEET OF  
CY74FCT480BTPC**



# CY54FCT480T, CY74FCT480T DUAL 8-BIT PARITY GENERATORS/CHECKERS

SCCS025B – MAY 1993 – REVISED OCTOBER 2001

- Function, Pinout, and Drive Compatible With FCT and F Logic
- Reduced  $V_{OH}$  (Typically = 3.3 V) Versions of Equivalent FCT Functions
- Edge-Rate Control Circuitry for Significantly Improved Noise Characteristics
- $I_{off}$  Supports Partial-Power-Down Mode Operation
- Matched Rise and Fall Times
- Fully Compatible With TTL Input and Output Logic Levels
- Two 8-Bit Parity Generators/Checkers
- Open-Drain Active-Low Parity-Error Output
- Expandable for Larger Word Widths
- ESD Protection Exceeds JESD 22
  - 2000-V Human-Body Model (A114-A)
  - 200-V Machine Model (A115-A)
  - 1000-V Charged-Device Model (C101)
- CY54FCT480T
  - 32-mA Output Sink Current
  - 12-mA Output Source Current
- CY74FCT480T
  - 64-mA Output Sink Current
  - 32-mA Output Source Current

## description

The 'FCT480T devices are high-speed, dual, 8-bit parity generators/checkers. Each parity generator/checker accepts eight data bits and one parity bit as inputs, and generates a sum and parity-error ( $\overline{ERROR}$ ) output. These devices can be used in odd-parity systems.  $\overline{ERROR}$  is an open-drain output designed for easy expansion of the word width by a wired-OR connection of several 'FCT480T devices. Because no additional logic is needed, the parity-generation or parity-checking times remain the same as for an individual 'FCT480T device.

These devices are fully specified for partial-power-down applications using  $I_{off}$ . The  $I_{off}$  circuitry disables the outputs, preventing damaging current backflow through the device when it is powered down.

CY74FCT480T . . . P, Q, OR SO PACKAGE  
(TOP VIEW)

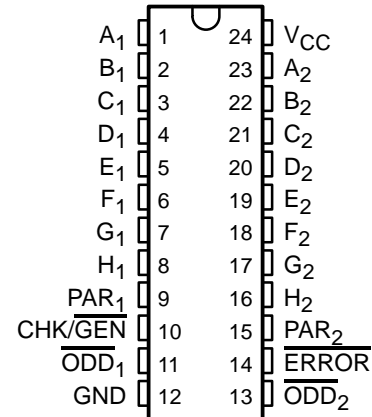

CY54FCT480T . . . L PACKAGE  
(TOP VIEW)

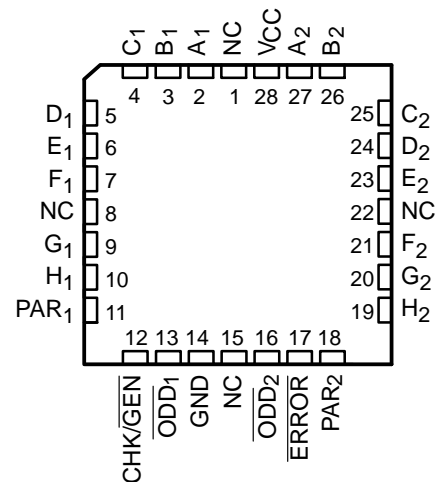

NC – No internal connection



Please be aware that an important notice concerning availability, standard warranty, and use in critical applications of Texas Instruments semiconductor products and disclaimers thereto appears at the end of this data sheet.

PRODUCTION DATA information is current as of publication date. Products conform to specifications per the terms of Texas Instruments standard warranty. Production processing does not necessarily include testing of all parameters.

**TEXAS  
INSTRUMENTS**

POST OFFICE BOX 655303 • DALLAS, TEXAS 75265

Copyright © 2001, Texas Instruments Incorporated  
On products compliant to MIL-PRF-38535, all parameters are tested unless otherwise noted. On all other products, production processing does not necessarily include testing of all parameters.

# CY54FCT480T, CY74FCT480T DUAL 8-BIT PARITY GENERATORS/CHECKERS

SCCS025B – MAY 1993 – REVISED OCTOBER 2001

## ORDERING INFORMATION

TA	PACKAGE†		SPEED (ns)	ORDERABLE PART NUMBER	TOP-SIDE MARKING
-40°C to 85°C	DIP – P	Tube	6.1	CY74FCT480BTPC	CY74FCT480BTPC
	QSOP – Q	Tape and reel	6.1	CY74FCT480BTQCT	FCT480B
	SOIC – SO	Tube	6.1	CY74FCT480BTSOC	FCT480B
		Tape and reel	6.1	CY74FCT480BTSOCT	
	DIP – P	Tube	7.5	CY74FCT480ATPC	CY74FCT480ATPC
	QSOP – Q	Tape and reel	7.5	CY74FCT480ATQCT	FCT480A
-55°C to 125°C	LCC – L	Tube	7	CY54FCT480BTLMB	

† Package drawings, standard packing quantities, thermal data, symbolization, and PCB design guidelines are available at [www.ti.com/sc/package](http://www.ti.com/sc/package).

## FUNCTION TABLE

INPUTS					OUTPUTS			
A <sub>1</sub> –H <sub>1</sub>	A <sub>2</sub> –H <sub>2</sub>	CHK/ $\overline{\text{GEN}}$	PAR <sub>1</sub>	PAR <sub>2</sub>	$\overline{\text{ODD}}_1$	$\overline{\text{ODD}}_2$	$\overline{\text{ERROR}}$	
Number of A <sub>1</sub> –H <sub>1</sub> inputs, high is even	Number of A <sub>2</sub> –H <sub>2</sub> inputs, high is even	H	H	H	L	L	H	
		H	L	H	H	L	L	
		H	H	L	L	H	H	L
		H	L	L	L	H	H	L
		L	X	X	X	H	H	L
	Number of inputs A <sub>2</sub> –H <sub>2</sub> , high is odd	H	H	H	L	H	L	L
		H	L	H	L	H	H	L
		H	H	L	L	L	L	H
		H	L	L	L	H	L	L
		L	X	X	X	H	L	L
Number of A <sub>1</sub> –H <sub>1</sub> inputs, high is odd	Number of A <sub>2</sub> –H <sub>2</sub> inputs, high is even	H	H	H	H	L	L	
		H	L	H	L	L	H	
		H	H	L	L	H	H	L
		H	L	L	L	L	H	L
		L	X	X	X	L	H	L
	Number of A <sub>2</sub> –H <sub>2</sub> inputs, high is odd	H	H	H	L	H	H	L
		H	L	H	L	L	H	L
		H	H	L	L	H	L	L
		H	L	L	L	L	L	H
		L	X	X	X	L	L	H

H = High logic level, L = Low logic level, X = Don't care



# CY54FCT480T, CY74FCT480T DUAL 8-BIT PARITY GENERATORS/CHECKERS

SCCS025B – MAY 1993 – REVISED OCTOBER 2001

## logic diagram

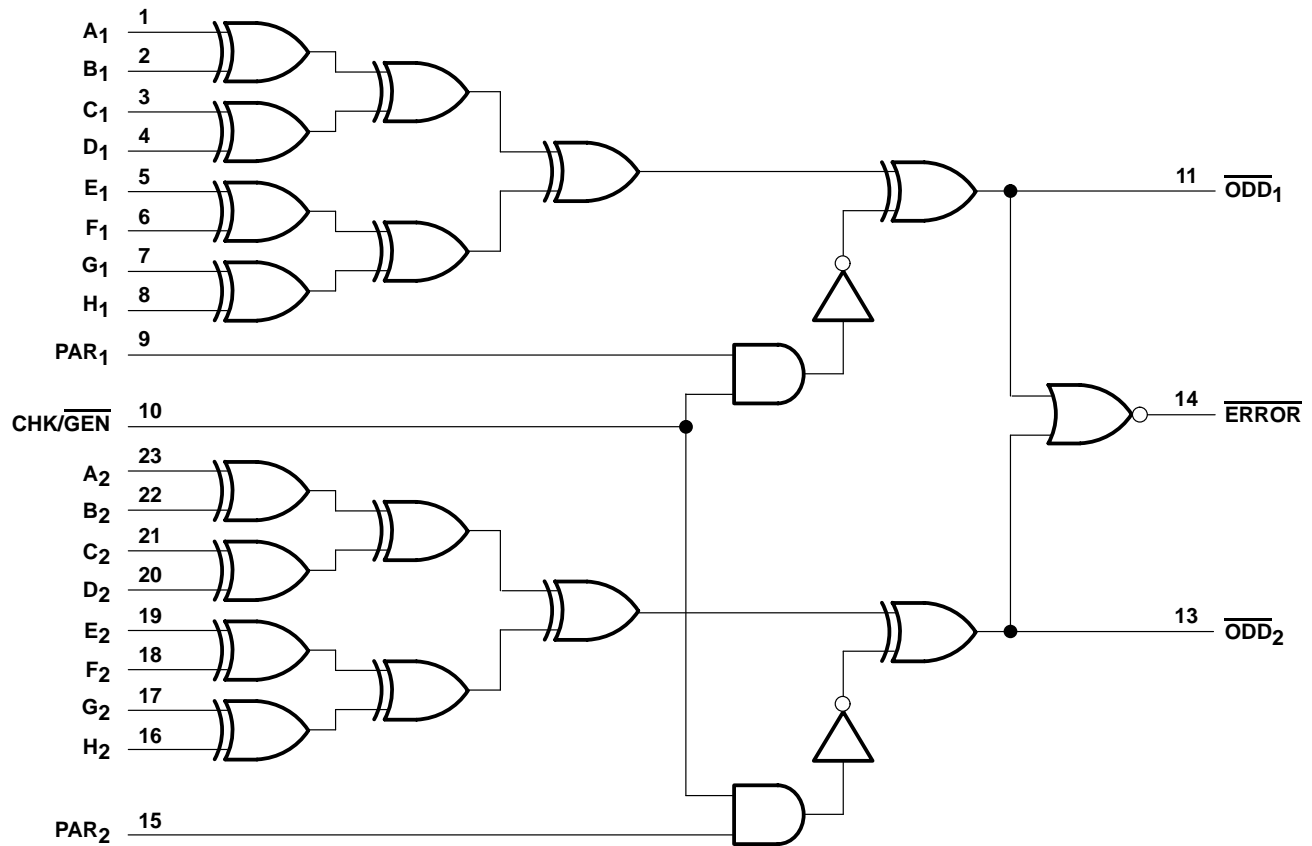

Pin numbers shown are for the P, Q, and SO packages.

## absolute maximum ratings over operating free-air temperature range (unless otherwise noted)<sup>†</sup>

Supply voltage range to ground potential	–0.5 V to 7 V
DC input voltage range	–0.5 V to 7 V
DC output voltage range	–0.5 V to 7 V
DC output current (maximum sink current/pin)	120 mA
Package thermal impedance, $\theta_{JA}$ (see Note 1): P package	67°C/W
(see Note 2): Q package	61°C/W
(see Note 2): SO package	46°C/W
Ambient temperature range with power applied, $T_A$	–65°C to 135°C
Storage temperature range, $T_{Stg}$	–65°C to 150°C

<sup>†</sup> Stresses beyond those listed under “absolute maximum ratings” may cause permanent damage to the device. These are stress ratings only, and functional operation of the device at these or any other conditions beyond those indicated under “recommended operating conditions” is not implied.

Exposure to absolute-maximum-rated conditions for extended periods may affect device reliability.

- NOTES: 1. The package thermal impedance is calculated in accordance with JESD 51-3.  
2. The package thermal impedance is calculated in accordance with JESD 51-7.

# CY54FCT480T, CY74FCT480T

## DUAL 8-BIT PARITY GENERATORS/CHECKERS

SCCS025B – MAY 1993 – REVISED OCTOBER 2001

### recommended operating conditions (see Note 3)

		CY54FCT480T			CY74FCT480T			UNIT
		MIN	NOM	MAX	MIN	NOM	MAX	
V <sub>CC</sub>	Supply voltage	4.5	5	5.5	4.75	5	5.25	V
V <sub>IH</sub>	High-level input voltage	2			2			V
V <sub>IL</sub>	Low-level input voltage			0.8			0.8	V
I <sub>OH</sub>	High-level output current			-12			-32	mA
I <sub>OL</sub>	Low-level output current			32			64	mA
T <sub>A</sub>	Operating free-air temperature	-55		125	-40		85	°C

NOTE 3: All unused inputs of the device must be held at V<sub>CC</sub> or GND to ensure proper device operation.

### electrical characteristics over recommended operating free-air temperature range (unless otherwise noted)

PARAMETER	TEST CONDITIONS	CY54FCT480T			CY74FCT480T			UNIT
		MIN	TYP†	MAX	MIN	TYP†	MAX	
V <sub>IK</sub>	V <sub>CC</sub> = 4.5 V, I <sub>IN</sub> = -18 mA		-0.7	-1.2				V
	V <sub>CC</sub> = 4.75 V, I <sub>IN</sub> = -18 mA				-0.7	-1.2		
V <sub>OH</sub>	V <sub>CC</sub> = 4.5 V, I <sub>OH</sub> = -12 mA	2.4	3.3					V
	V <sub>CC</sub> = 4.75 V	I <sub>OH</sub> = -15 mA			2.4	3.3		
		I <sub>OH</sub> = -32 mA			2			
V <sub>OL</sub>	V <sub>CC</sub> = 4.5 V, I <sub>OL</sub> = 32 mA		0.3	0.55				V
	V <sub>CC</sub> = 4.75 V, I <sub>OL</sub> = 64 mA				0.3	0.55		
V <sub>hys</sub>	All inputs		0.2		0.2			V
I <sub>I</sub>	V <sub>CC</sub> = 5.5 V, V <sub>IN</sub> = V <sub>CC</sub>			5				μA
	V <sub>CC</sub> = 5.25 V, V <sub>IN</sub> = V <sub>CC</sub>					5		
I <sub>IH</sub>	V <sub>CC</sub> = 5.5 V, V <sub>IN</sub> = 2.7 V			±1				μA
	V <sub>CC</sub> = 5.25 V, V <sub>IN</sub> = 2.7 V					±1		
I <sub>IL</sub>	V <sub>CC</sub> = 5.5 V, V <sub>IN</sub> = 0.5 V			±1				μA
	V <sub>CC</sub> = 5.25 V, V <sub>IN</sub> = 0.5 V					±1		
I <sub>off</sub>	V <sub>CC</sub> = 0 V, V <sub>OUT</sub> = 4.5 V			±1			±1	μA
I <sub>OS</sub> ‡	V <sub>CC</sub> = 5.5 V, V <sub>OUT</sub> = 0 V	-60	-120	-225				mA
	V <sub>CC</sub> = 5.25 V, V <sub>OUT</sub> = 0 V				-60	-120	-225	
I <sub>OZH</sub>	V <sub>CC</sub> = 5.5 V, V <sub>OUT</sub> = 2.7 V			10				μA
	V <sub>CC</sub> = 5.25 V, V <sub>OUT</sub> = 2.7 V					10		
I <sub>OZL</sub>	V <sub>CC</sub> = 5.5 V, V <sub>OUT</sub> = 0.5 V			-10				μA
	V <sub>CC</sub> = 5.25 V, V <sub>OUT</sub> = 0.5 V					-10		
I <sub>CC</sub>	V <sub>CC</sub> = 5.5 V, V <sub>IN</sub> ≤ 0.2 V, V <sub>IN</sub> ≥ V <sub>CC</sub> - 0.2 V		0.1	0.2				mA
	V <sub>CC</sub> = 5.25 V, V <sub>IN</sub> ≤ 0.2 V, V <sub>IN</sub> ≥ V <sub>CC</sub> - 0.2 V				0.1	0.2		
ΔI <sub>CC</sub>	V <sub>CC</sub> = 5.5 V, V <sub>IN</sub> = 3.4 V§, f <sub>1</sub> = 0, Outputs open		0.5	2				mA
	V <sub>CC</sub> = 5.25 V, V <sub>IN</sub> = 3.4 V§, f <sub>1</sub> = 0, Outputs open				0.5	2		

† Typical values are at V<sub>CC</sub> = 5 V, T<sub>A</sub> = 25°C.

‡ Not more than one output should be shorted at a time. Duration of short should not exceed one second. The use of high-speed test apparatus and/or sample-and-hold techniques are preferable to minimize internal chip heating and more accurately reflect operational values. Otherwise, prolonged shorting of a high output can raise the chip temperature well above normal and cause invalid readings in other parametric tests. In any sequence of parameter tests, I<sub>OS</sub> tests should be performed last.

§ Per TTL-driven input (V<sub>IN</sub> = 3.4 V); all other inputs at V<sub>CC</sub> or GND



# CY54FCT480T, CY74FCT480T DUAL 8-BIT PARITY GENERATORS/CHECKERS

SCCS025B – MAY 1993 – REVISED OCTOBER 2001

**electrical characteristics over recommended operating free-air temperature range (unless otherwise noted) (continued)**

PARAMETER	TEST CONDITIONS		CY54FCT480T		CY74FCT480T		UNIT	
			MIN	TYP†	MAX	MIN		TYP†
$I_{CCD}^{\ddagger}$	V <sub>CC</sub> = 5.5 V, Outputs open, One bit switching at 50% duty cycle, V <sub>IN</sub> ≤ 0.2 V or V <sub>IN</sub> ≥ V <sub>CC</sub> – 0.2 V		0.06	0.12			mA/ MHz	
	V <sub>CC</sub> = 5.25 V, Outputs open, One bit switching at 50% duty cycle, V <sub>IN</sub> ≤ 0.2 V or V <sub>IN</sub> ≥ V <sub>CC</sub> – 0.2 V				0.06	0.12		
$I_C^{\#}$	V <sub>CC</sub> = 5.5 V, f <sub>0</sub> = 0 MHz, Outputs open	One bit switching at f <sub>1</sub> = 2.5 MHz at 50% duty cycle	V <sub>IN</sub> ≤ 0.2 V or V <sub>IN</sub> ≥ V <sub>CC</sub> – 0.2 V	0.7	1.4		mA	
			V <sub>IN</sub> = 3.4 V or GND	1	2.4			
		16 bits switching at f <sub>1</sub> = 2.5 MHz at 50% duty cycle	V <sub>IN</sub> ≤ 0.2 V or V <sub>IN</sub> ≥ V <sub>CC</sub> – 0.2 V	2.5	5			
			V <sub>IN</sub> = 3.4 V or GND	6.5	21			
	V <sub>CC</sub> = 5.25 V, f <sub>0</sub> = 0 MHz, Outputs open	One bit switching at f <sub>1</sub> = 2.5 MHz at 50% duty cycle	V <sub>IN</sub> ≤ 0.2 V or V <sub>IN</sub> ≥ V <sub>CC</sub> – 0.2 V			0.7		1.4
			V <sub>IN</sub> = 3.4 V or GND			1		2.4
		16 bits switching at f <sub>1</sub> = 2.5 MHz at 50% duty cycle	V <sub>IN</sub> ≤ 0.2 V or V <sub>IN</sub> ≥ V <sub>CC</sub> – 0.2 V			2.5		5
			V <sub>IN</sub> = 3.4 V or GND			6.5		21
C <sub>i</sub>			5	10	5	10	pF	
C <sub>o</sub>			9	12	9	12	pF	

† Typical values are at V<sub>CC</sub> = 5 V, T<sub>A</sub> = 25°C.

‡ This parameter is derived for use in total power-supply calculations.

#  $I_C = I_{CC} + \Delta I_{CC} \times D_H \times N_T + I_{CCD} (f_0/2 + f_1 \times N_1)$

Where:

I<sub>C</sub> = Total supply current

I<sub>CC</sub> = Power-supply current with CMOS input levels

ΔI<sub>CC</sub> = Power-supply current for a TTL high input (V<sub>IN</sub> = 3.4 V)

D<sub>H</sub> = Duty cycle for TTL inputs high

N<sub>T</sub> = Number of TTL inputs at D<sub>H</sub>

I<sub>CCD</sub> = Dynamic current caused by an input transition pair (HLH or LHL)

f<sub>0</sub> = Clock frequency for registered devices, otherwise zero

f<sub>1</sub> = Input signal frequency

N<sub>1</sub> = Number of inputs changing at f<sub>1</sub>

All currents are in milliamperes and all frequencies are in megahertz.

|| Values for these conditions are examples of the I<sub>CC</sub> formula.



# CY54FCT480T, CY74FCT480T DUAL 8-BIT PARITY GENERATORS/CHECKERS

SCCS025B – MAY 1993 – REVISED OCTOBER 2001

## switching characteristics over operating free-air temperature range (see Figure 1)

PARAMETER	FROM (INPUT)	TO (OUTPUT)	CY74FCT480AT		CY54FCT480BT		CY74FCT480BT		UNIT
			MIN	MAX	MIN	MAX	MIN	MAX	
t <sub>PLH</sub>	A	$\overline{\text{ODD}}$ (see Figure 1)	7.5		7		6.1		ns
t <sub>PHL</sub>			7		6.6		6.1		
t <sub>PLH</sub>	CHK/ $\overline{\text{GEN}}$	$\overline{\text{ODD}}$ (see Figure 1)	6.5		6.3		5.9		ns
t <sub>PHL</sub>			7.5		7.4		5.9		
t <sub>PLH</sub> <sup>†</sup>	A	$\overline{\text{ERROR}}$ (see Figure 2)	7		7		6.1		ns
t <sub>PHL</sub>			8.5		8.1		6.5		
t <sub>PLH</sub>	CHK/ $\overline{\text{GEN}}$	$\overline{\text{ERROR}}$ (see Figure 2)	7.5		7.1		5.7		ns
t <sub>PHL</sub>			7		6.9		5.5		

<sup>†</sup> t<sub>PLH</sub> is measured up to V<sub>OUT</sub> = V<sub>OL</sub> + 0.3 V.



PARAMETER MEASUREMENT INFORMATION

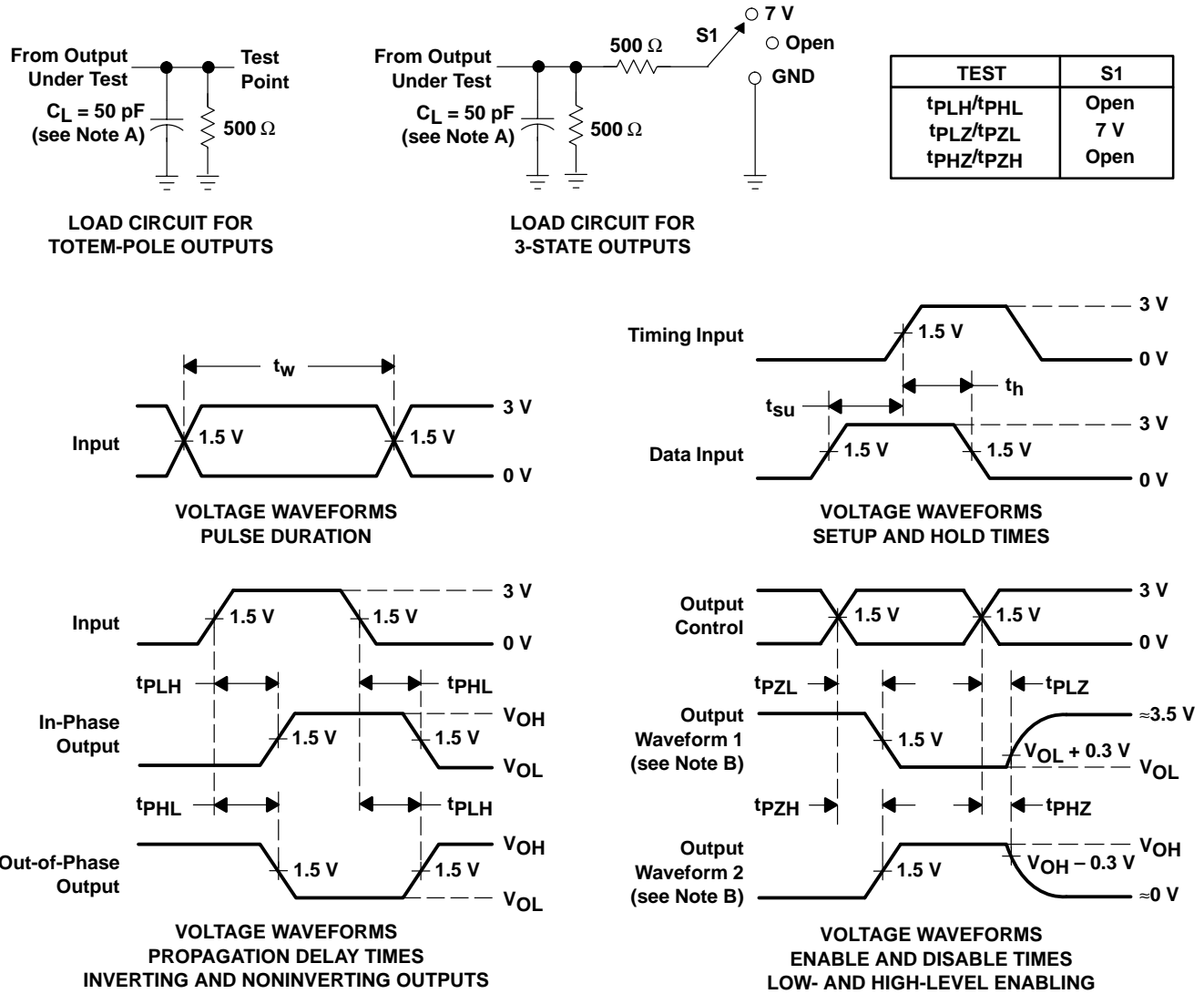

- NOTES: A.  $C_L$  includes probe and jig capacitance.  
 B. Waveform 1 is for an output with internal conditions such that the output is low except when disabled by the output control. Waveform 2 is for an output with internal conditions such that the output is high except when disabled by the output control.  
 C. The outputs are measured one at a time with one input transition per measurement.

Figure 1. Load Circuit and Voltage Waveforms

# CY54FCT480T, CY74FCT480T DUAL 8-BIT PARITY GENERATORS/CHECKERS

SCCS025B – MAY 1993 – REVISED OCTOBER 2001

## PARAMETER MEASUREMENT INFORMATION FOR OPEN-DRAIN OUTPUTS

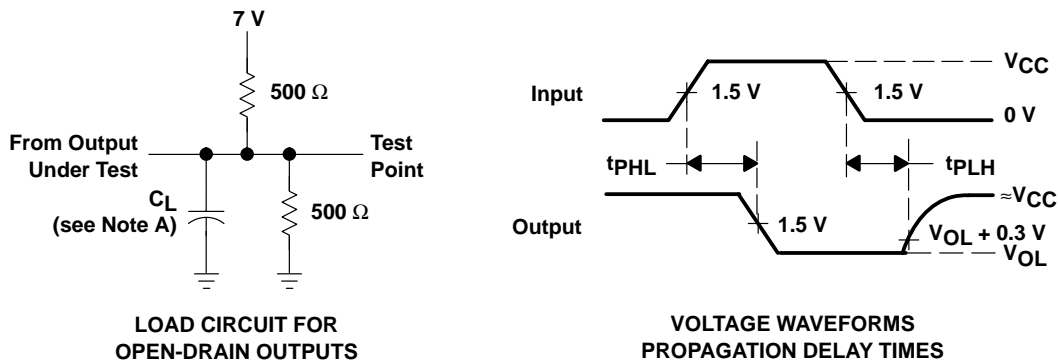

- NOTES: A.  $C_L$  includes probe and jig capacitance.  
 B. All input pulses are supplied by generators having the following characteristics:  $PRR \leq 1$  MHz,  $Z_O = 50 \Omega$ ,  $t_r \leq 3$  ns,  $t_f \leq 3$  ns.  
 C. The outputs are measured one at a time with one input transition per measurement.

Figure 2. Load Circuit and Voltage Waveforms

**PACKAGING INFORMATION**

Orderable Device	Status (1)	Package Type	Package Drawing	Pins	Package Qty	Eco Plan (2)	Lead/Ball Finish (6)	MSL Peak Temp (3)	Op Temp (°C)	Device Marking (4/5)	Samples
CY54FCT480BTLMB	ACTIVE	LCCC	FK	28	1	TBD	POST-PLATE	N / A for Pkg Type	-55 to 125	CY54FCT 480BTLMB	Samples
CY74FCT480BTPC	OBSOLETE	PDIP	NT	24		TBD	Call TI	Call TI	-40 to 85		
CY74FCT480BTPCE4	OBSOLETE	PDIP	NT	24		TBD	Call TI	Call TI	-40 to 85		
CY74FCT480BTQCT	OBSOLETE	SSOP	DBQ	24		TBD	Call TI	Call TI	-40 to 85		
CY74FCT480BTQCTE4	OBSOLETE	SSOP	DBQ	24		TBD	Call TI	Call TI	-40 to 85		
CY74FCT480BTQCTG4	OBSOLETE	SSOP	DBQ	24		TBD	Call TI	Call TI	-40 to 85		

(1) The marketing status values are defined as follows:

**ACTIVE:** Product device recommended for new designs.

**LIFEBUY:** TI has announced that the device will be discontinued, and a lifetime-buy period is in effect.

**NRND:** Not recommended for new designs. Device is in production to support existing customers, but TI does not recommend using this part in a new design.

**PREVIEW:** Device has been announced but is not in production. Samples may or may not be available.

**OBSOLETE:** TI has discontinued the production of the device.

(2) Eco Plan - The planned eco-friendly classification: Pb-Free (RoHS), Pb-Free (RoHS Exempt), or Green (RoHS & no Sb/Br) - please check <http://www.ti.com/productcontent> for the latest availability information and additional product content details.

**TBD:** The Pb-Free/Green conversion plan has not been defined.

**Pb-Free (RoHS):** TI's terms "Lead-Free" or "Pb-Free" mean semiconductor products that are compatible with the current RoHS requirements for all 6 substances, including the requirement that lead not exceed 0.1% by weight in homogeneous materials. Where designed to be soldered at high temperatures, TI Pb-Free products are suitable for use in specified lead-free processes.

**Pb-Free (RoHS Exempt):** This component has a RoHS exemption for either 1) lead-based flip-chip solder bumps used between the die and package, or 2) lead-based die adhesive used between the die and leadframe. The component is otherwise considered Pb-Free (RoHS compatible) as defined above.

**Green (RoHS & no Sb/Br):** TI defines "Green" to mean Pb-Free (RoHS compatible), and free of Bromine (Br) and Antimony (Sb) based flame retardants (Br or Sb do not exceed 0.1% by weight in homogeneous material)

(3) MSL, Peak Temp. - The Moisture Sensitivity Level rating according to the JEDEC industry standard classifications, and peak solder temperature.

(4) There may be additional marking, which relates to the logo, the lot trace code information, or the environmental category on the device.

(5) Multiple Device Markings will be inside parentheses. Only one Device Marking contained in parentheses and separated by a "~" will appear on a device. If a line is indented then it is a continuation of the previous line and the two combined represent the entire Device Marking for that device.

(6) Lead/Ball Finish - Orderable Devices may have multiple material finish options. Finish options are separated by a vertical ruled line. Lead/Ball Finish values may wrap to two lines if the finish value exceeds the maximum column width.

**Important Information and Disclaimer:** The information provided on this page represents TI's knowledge and belief as of the date that it is provided. TI bases its knowledge and belief on information provided by third parties, and makes no representation or warranty as to the accuracy of such information. Efforts are underway to better integrate information from third parties. TI has taken and continues to take reasonable steps to provide representative and accurate information but may not have conducted destructive testing or chemical analysis on incoming materials and chemicals. TI and TI suppliers consider certain information to be proprietary, and thus CAS numbers and other limited information may not be available for release.

In no event shall TI's liability arising out of such information exceed the total purchase price of the TI part(s) at issue in this document sold by TI to Customer on an annual basis.

## IMPORTANT NOTICE

Texas Instruments Incorporated and its subsidiaries (TI) reserve the right to make corrections, enhancements, improvements and other changes to its semiconductor products and services per JESD46, latest issue, and to discontinue any product or service per JESD48, latest issue. Buyers should obtain the latest relevant information before placing orders and should verify that such information is current and complete. All semiconductor products (also referred to herein as "components") are sold subject to TI's terms and conditions of sale supplied at the time of order acknowledgment.

TI warrants performance of its components to the specifications applicable at the time of sale, in accordance with the warranty in TI's terms and conditions of sale of semiconductor products. Testing and other quality control techniques are used to the extent TI deems necessary to support this warranty. Except where mandated by applicable law, testing of all parameters of each component is not necessarily performed.

TI assumes no liability for applications assistance or the design of Buyers' products. Buyers are responsible for their products and applications using TI components. To minimize the risks associated with Buyers' products and applications, Buyers should provide adequate design and operating safeguards.

TI does not warrant or represent that any license, either express or implied, is granted under any patent right, copyright, mask work right, or other intellectual property right relating to any combination, machine, or process in which TI components or services are used. Information published by TI regarding third-party products or services does not constitute a license to use such products or services or a warranty or endorsement thereof. Use of such information may require a license from a third party under the patents or other intellectual property of the third party, or a license from TI under the patents or other intellectual property of TI.

Reproduction of significant portions of TI information in TI data books or data sheets is permissible only if reproduction is without alteration and is accompanied by all associated warranties, conditions, limitations, and notices. TI is not responsible or liable for such altered documentation. Information of third parties may be subject to additional restrictions.

Resale of TI components or services with statements different from or beyond the parameters stated by TI for that component or service voids all express and any implied warranties for the associated TI component or service and is an unfair and deceptive business practice. TI is not responsible or liable for any such statements.

Buyer acknowledges and agrees that it is solely responsible for compliance with all legal, regulatory and safety-related requirements concerning its products, and any use of TI components in its applications, notwithstanding any applications-related information or support that may be provided by TI. Buyer represents and agrees that it has all the necessary expertise to create and implement safeguards which anticipate dangerous consequences of failures, monitor failures and their consequences, lessen the likelihood of failures that might cause harm and take appropriate remedial actions. Buyer will fully indemnify TI and its representatives against any damages arising out of the use of any TI components in safety-critical applications.

In some cases, TI components may be promoted specifically to facilitate safety-related applications. With such components, TI's goal is to help enable customers to design and create their own end-product solutions that meet applicable functional safety standards and requirements. Nonetheless, such components are subject to these terms.

No TI components are authorized for use in FDA Class III (or similar life-critical medical equipment) unless authorized officers of the parties have executed a special agreement specifically governing such use.

Only those TI components which TI has specifically designated as military grade or "enhanced plastic" are designed and intended for use in military/aerospace applications or environments. Buyer acknowledges and agrees that any military or aerospace use of TI components which have **not** been so designated is solely at the Buyer's risk, and that Buyer is solely responsible for compliance with all legal and regulatory requirements in connection with such use.

TI has specifically designated certain components as meeting ISO/TS16949 requirements, mainly for automotive use. In any case of use of non-designated products, TI will not be responsible for any failure to meet ISO/TS16949.

### Products

Audio	<a href="http://www.ti.com/audio">www.ti.com/audio</a>
Amplifiers	<a href="http://amplifier.ti.com">amplifier.ti.com</a>
Data Converters	<a href="http://dataconverter.ti.com">dataconverter.ti.com</a>
DLP® Products	<a href="http://www.dlp.com">www.dlp.com</a>
DSP	<a href="http://dsp.ti.com">dsp.ti.com</a>
Clocks and Timers	<a href="http://www.ti.com/clocks">www.ti.com/clocks</a>
Interface	<a href="http://interface.ti.com">interface.ti.com</a>
Logic	<a href="http://logic.ti.com">logic.ti.com</a>
Power Mgmt	<a href="http://power.ti.com">power.ti.com</a>
Microcontrollers	<a href="http://microcontroller.ti.com">microcontroller.ti.com</a>
RFID	<a href="http://www.ti-rfid.com">www.ti-rfid.com</a>
OMAP Applications Processors	<a href="http://www.ti.com/omap">www.ti.com/omap</a>
Wireless Connectivity	<a href="http://www.ti.com/wirelessconnectivity">www.ti.com/wirelessconnectivity</a>

### Applications

Automotive and Transportation	<a href="http://www.ti.com/automotive">www.ti.com/automotive</a>
Communications and Telecom	<a href="http://www.ti.com/communications">www.ti.com/communications</a>
Computers and Peripherals	<a href="http://www.ti.com/computers">www.ti.com/computers</a>
Consumer Electronics	<a href="http://www.ti.com/consumer-apps">www.ti.com/consumer-apps</a>
Energy and Lighting	<a href="http://www.ti.com/energy">www.ti.com/energy</a>
Industrial	<a href="http://www.ti.com/industrial">www.ti.com/industrial</a>
Medical	<a href="http://www.ti.com/medical">www.ti.com/medical</a>
Security	<a href="http://www.ti.com/security">www.ti.com/security</a>
Space, Avionics and Defense	<a href="http://www.ti.com/space-avionics-defense">www.ti.com/space-avionics-defense</a>
Video and Imaging	<a href="http://www.ti.com/video">www.ti.com/video</a>

### TI E2E Community

[e2e.ti.com](http://e2e.ti.com)

## Looking for pricing, stock, or lifecycle information?

Click below to explore more details on WIN SOURCE:

 [View CY74FCT480BTPC on WIN SOURCE](#)

 [Texas Instruments](#) Information

## Optimize Your Supply Chain with WIN SOURCE Solutions

-  Global Sourcing Solution
-  Obsolete Management
-  Cost Control Management
-  Shortage Management
-  Alternative Solution
-  Excess Inventory Management