



**THE DATASHEET OF
CY6264-70SNXC**



Features

- Temperature ranges:
 - Commercial: 0 °C to 70 °C
 - Industrial: -40 °C to 85 °C
 - Automotive-A: -40 °C to 85 °C
- High speed
 - 55 ns
- CMOS for optimum speed/power
- Easy memory expansion with \overline{CE}_1 , CE_2 and \overline{OE} features
- TTL-compatible inputs and outputs
- Automatic power-down when deselected
- Available in Pb-free 28-pin SNC package

Functional Description

The CY6264 is a high-performance CMOS static RAM organized as 8192 words by 8 bits. Easy memory expansion is provided by an active LOW chip enable (\overline{CE}_1), an active HIGH chip enable (CE_2), and active LOW output enable (\overline{OE}) and three-state drivers. Both devices have an automatic power-down feature (\overline{CE}_1), reducing the power consumption by over 70% when deselected. The CY6264 is packaged in a 450-mil (300-mil body) SOIC.

An active LOW write enable signal (\overline{WE}) controls the writing/reading operation of the memory. When \overline{CE}_1 and \overline{WE} inputs are both LOW and CE_2 is HIGH, data on the eight data input/output pins (I/O_0 through I/O_7) is written into the memory location addressed by the address present on the address pins (A_0 through A_{12}). Reading the device is accomplished by selecting the device and enabling the outputs, \overline{CE}_1 and \overline{OE} active LOW, CE_2 active HIGH, while \overline{WE} remains inactive or HIGH. Under these conditions, the contents of the location addressed by the information on address pins is present on the eight data input/output pins.

The input/output pins remain in a high-impedance state unless the chip is selected, outputs are enabled, and write enable (\overline{WE}) is HIGH. A die coat is used to ensure alpha immunity.

For a complete list of related documentation, click [here](#).

Logic Block Diagram

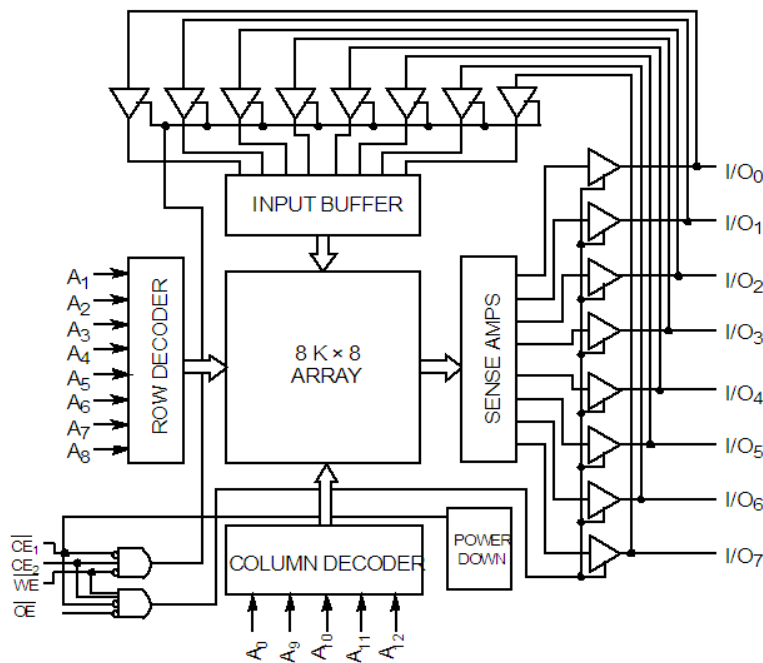

Contents

Pin Configuration	3	Package Diagram	13
Selection Guide	3	Acronyms	14
Maximum Ratings	4	Document Conventions	14
Operating Range	4	Units of Measure	14
Electrical Characteristics	4	Document History Page	15
Capacitance	5	Sales, Solutions, and Legal Information	16
AC Test Loads and Waveforms	5	Worldwide Sales and Design Support	16
Switching Characteristics	6	Products	16
Switching Waveforms	7	PSoC@Solutions	16
Typical DC and AC Characteristics	10	Cypress Developer Community	16
Truth Table	11	Technical Support	16
Address Designators	11		
Ordering Information	12		
Ordering Code Definitions	12		

Pin Configuration

Figure 1. 28-pin SOIC pinout (Top View)

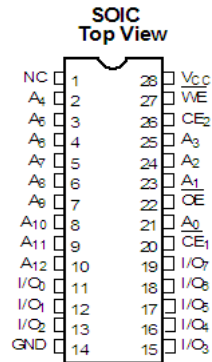

Selection Guide

Description	Range	-55	-70	Unit
Maximum access time		55	70	ns
Maximum operating current	Commercial	100	100	mA
	Industrial	260	200	mA
	Automotive-A	–	200	mA
Maximum CMOS standby current	Commercial	15	15	mA
	Industrial	30	30	mA
	Automotive-A	–	30	mA

Maximum Ratings

Exceeding maximum ratings may shorten the useful life of the device. User guidelines are not tested.

- Storage temperature -65 °C to +150 °C
- Ambient temperature with power applied -55 °C to +125 °C
- Supply voltage to ground potential ^[1] -0.5 V to +7.0 V
- DC voltage applied to outputs in high Z state ^[1] -0.5 V to +7.0 V
- DC input voltage ^[1] -0.5 V to +7.0 V

- Output current into outputs (LOW) 20 mA
- Static discharge voltage (per MIL-STD-883, Method 3015) > 2001 V
- Latch-up current > 200 mA

Operating Range

Range	Ambient Temperature	V _{CC}
Commercial	0 °C to +70 °C	5 V ± 10%
Industrial	-40 °C to +85 °C	
Automotive-A	-40 °C to +85 °C	

Electrical Characteristics

Over the Operating Range

Parameter	Description	Test Conditions	-55		-70		Unit	
			Min	Max	Min	Max		
V _{OH}	Output HIGH voltage	V _{CC} = Min, I _{OH} = -4.0 mA	2.4	-	2.4	-	V	
V _{OL}	Output LOW voltage	V _{CC} = Min, I _{OL} = 8.0 mA	-	0.4	-	0.4	V	
V _{IH}	Input HIGH voltage		2.2	V _{CC}	2.2	V _{CC}	V	
V _{IL}	Input LOW voltage ^[1]		-0.5	0.8	-0.5	0.8	V	
I _{IX}	Input leakage current	GND ≤ V _I ≤ V _{CC}	-5	+5	-5	+5	μA	
I _{OZ}	Output leakage current	GND ≤ V _I ≤ V _{CC} , output disabled	-5	+5	-5	+5	μA	
I _{CC}	V _{CC} operating supply current	V _{CC} = Max, I _{OUT} = 0 mA	Commercial	-	100	-	100	mA
			Industrial	-	260	-	200	
			Automotive-A	-		-	200	
I _{SB1}	Automatic \overline{CE}_1 power-down current	Max V _{CC} , $\overline{CE}_1 \geq V_{IH}$, Min duty cycle = 100%	Commercial	-	20	-	20	mA
			Industrial	-	50	-	40	
			Automotive-A	-		-	40	
I _{SB2}	Automatic \overline{CE}_1 power-down current	Max V _{CC} , $\overline{CE}_1 \geq V_{CC} - 0.3 V$, $V_{IN} \geq V_{CC} - 0.3 V$ or $V_{IN} \leq 0.3 V$	Commercial	-	15	-	15	mA
			Industrial	-	30	-	30	
			Automotive-A	-		-	30	

Note

1. Minimum voltage is equal to -3.0 V for pulse durations less than 30 ns.

Capacitance

Parameter [2]	Description	Test Conditions	Max	Unit
C_{IN}	Input capacitance	$T_A = 25\text{ }^\circ\text{C}$, $f = 1\text{ MHz}$, $V_{CC} = 5.0\text{ V}$	7	pF
C_{OUT}	Output capacitance		7	pF

AC Test Loads and Waveforms

Figure 2. AC Test Loads and Waveforms

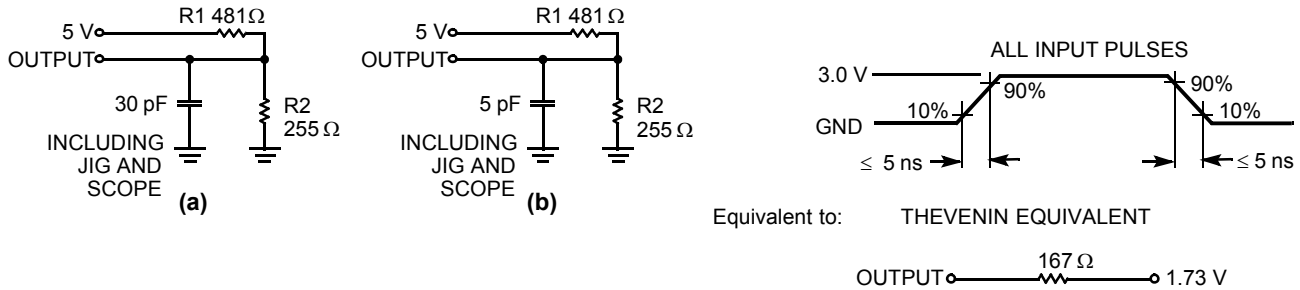

Note

2. Tested initially and after any design or process changes that may affect these parameters.

Switching Characteristics

Over the Operating Range

Parameter ^[3]	Description	-55		-70		Unit
		Min	Max	Min	Max	
READ CYCLE						
t _{RC}	Read cycle time	55	–	70	–	ns
t _{AA}	Address to data valid	–	55	–	70	ns
t _{OHA}	Data hold from address change	5	–	5	–	ns
t _{ACE1}	\overline{CE}_1 LOW to data valid	–	55	–	70	ns
t _{ACE2}	CE ₂ HIGH to data valid	–	40	–	70	ns
t _{DOE}	\overline{OE} LOW to data valid	–	25	–	35	ns
t _{LZOE}	\overline{OE} LOW to low Z	3	–	5	–	ns
t _{HZOE}	\overline{OE} HIGH to high Z ^[4]	–	20	–	30	ns
t _{LZCE1}	\overline{CE}_1 LOW to low Z ^[5]	5	–	5	–	ns
t _{LZCE2}	CE ₂ HIGH to low Z	3	–	5	–	ns
t _{HZCE}	\overline{CE}_1 HIGH to high Z ^[4, 6] CE ₂ LOW to high Z	–	20	–	30	ns
t _{PU}	\overline{CE}_1 LOW to power-up	0	–	0	–	ns
t _{PD}	\overline{CE}_1 HIGH to power-down	–	25	–	30	ns
WRITE CYCLE ^[6, 7]						
t _{WC}	Write cycle time	50	–	70	–	ns
t _{SCE1}	\overline{CE}_1 LOW to write end	40	–	60	–	ns
t _{SCE2}	CE ₂ HIGH to write end	30	–	50	–	ns
t _{AW}	Address setup to write end	40	–	55	–	ns
t _{HA}	Address hold from write end	0	–	0	–	ns
t _{SA}	Address setup to write start	0	–	0	–	ns
t _{PWE}	\overline{WE} pulse width	25	–	40	–	ns
t _{SD}	Data setup to write end	25	–	35	–	ns
t _{HD}	Data hold from write end	0	–	0	–	ns
t _{HZWE}	\overline{WE} LOW to high Z ^[4]	–	20	–	30	ns
t _{LZWE}	\overline{WE} HIGH to low Z	5	–	5	–	ns

Notes

3. Test conditions assume signal transition time of 5 ns or less, timing reference levels of 1.5 V, input pulse levels of 0 to 3.0 V, and output loading of the specified I_{OL}/I_{OH} and 30-pF load capacitance.
4. t_{HZOE}, t_{HZCE}, and t_{HZWE} are specified with C_L = 5 pF as in part (b) of AC Test Loads. Transition is measured ±500 mV from steady-state voltage.
5. At any temperature and voltage condition, t_{HZCE} is less than t_{LZCE} for any device.
6. The internal write time of the memory is defined by the overlap of \overline{CE}_1 LOW, CE₂ HIGH, and \overline{WE} LOW. Both signals must be LOW to initiate a write and either signal can terminate a write by going HIGH. The data input setup and hold timing should be referenced to the rising edge of the signal that terminates the write.
7. The minimum write cycle time for Write Cycle No. 3 (\overline{WE} Controlled, \overline{OE} LOW) is the sum of t_{HZWE} and t_{SD}.

Switching Waveforms

Figure 3. Read Cycle No. 1 [8, 9]

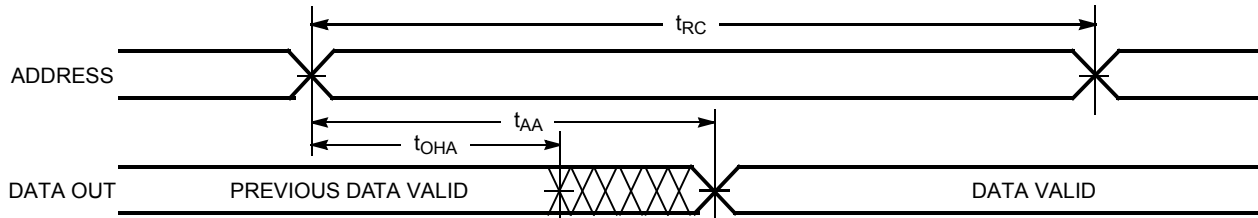
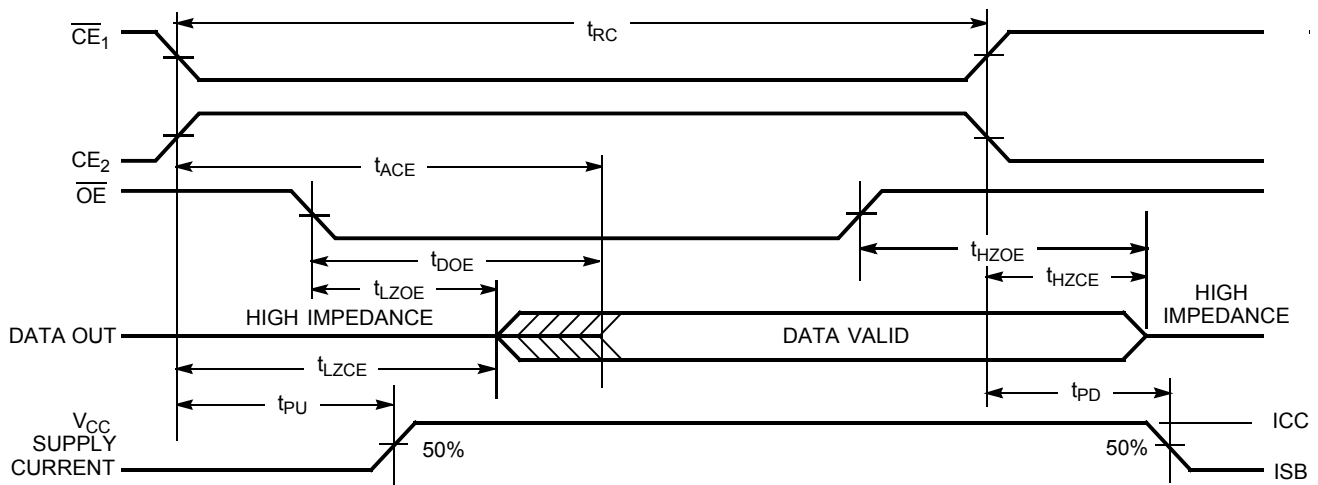

Figure 4. Read Cycle No. 2 [10, 11]



Notes

- 8. Device is continuously selected. \overline{OE} , $\overline{CE}_1 = V_{IL}$. $CE_2 = V_{IH}$.
- 9. Address valid prior to or coincident with \overline{CE} transition LOW.
- 10. \overline{WE} is HIGH for read cycle.
- 11. Data I/O is High Z if $\overline{OE} = V_{IH}$, $\overline{CE}_1 = V_{IH}$, or $\overline{WE} = V_{IL}$.

Switching Waveforms (continued)

Figure 5. Write Cycle No. 1 (\overline{WE} Controlled) [12, 13]

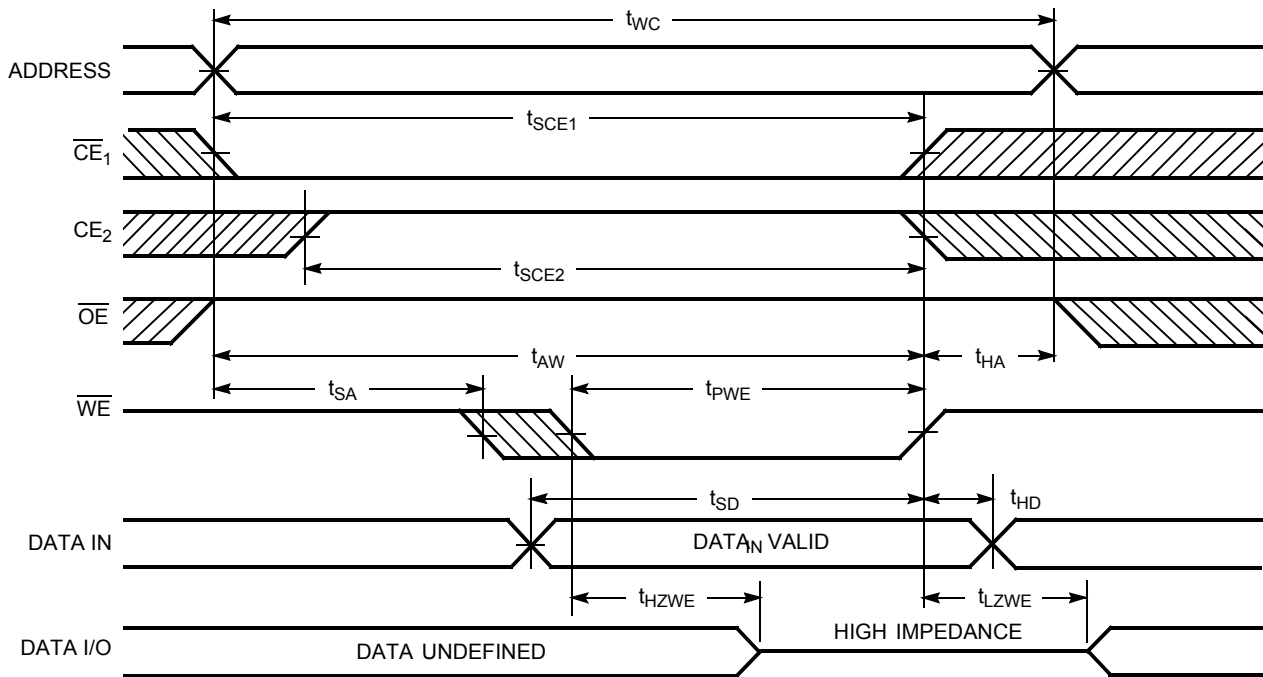
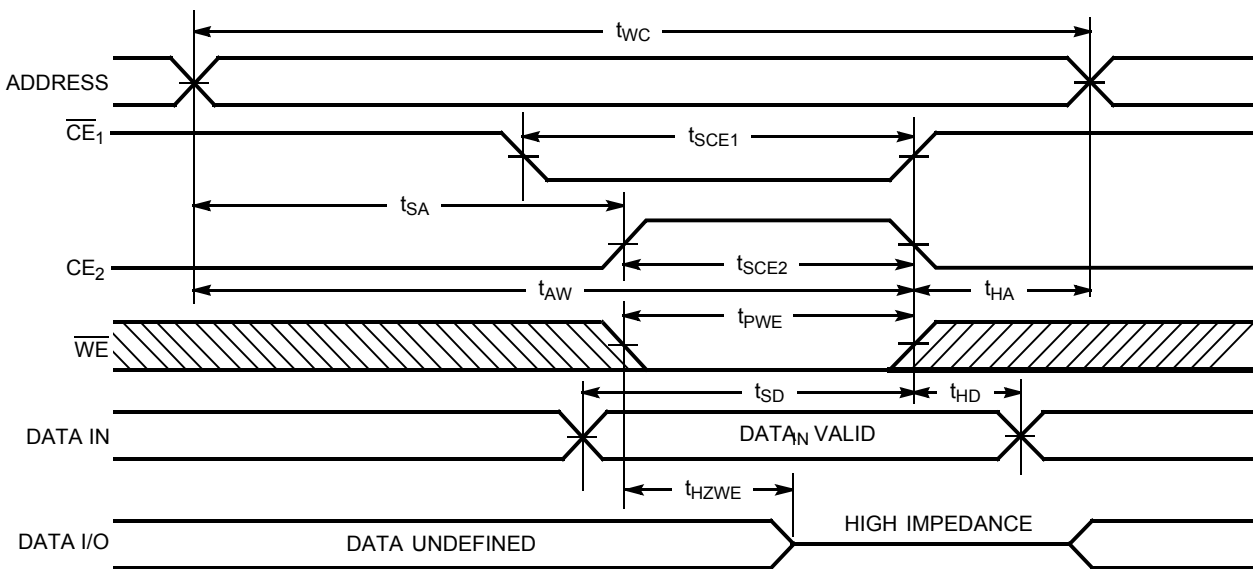

Figure 6. Write Cycle No. 2 (\overline{CE} Controlled) [12, 13, 14]



Notes

- 12. Address valid prior to or coincident with \overline{CE} transition LOW.
- 13. Data I/O is High Z if $OE = V_{IH}$, $CE_1 = V_{IH}$, or $WE = V_{IL}$.
- 14. If \overline{CE} goes HIGH simultaneously with \overline{WE} HIGH, the output remains in a high-impedance state.

Switching Waveforms (continued)

Figure 7. Write Cycle No. 3 (\overline{WE} Controlled, \overline{OE} LOW) [15, 16]

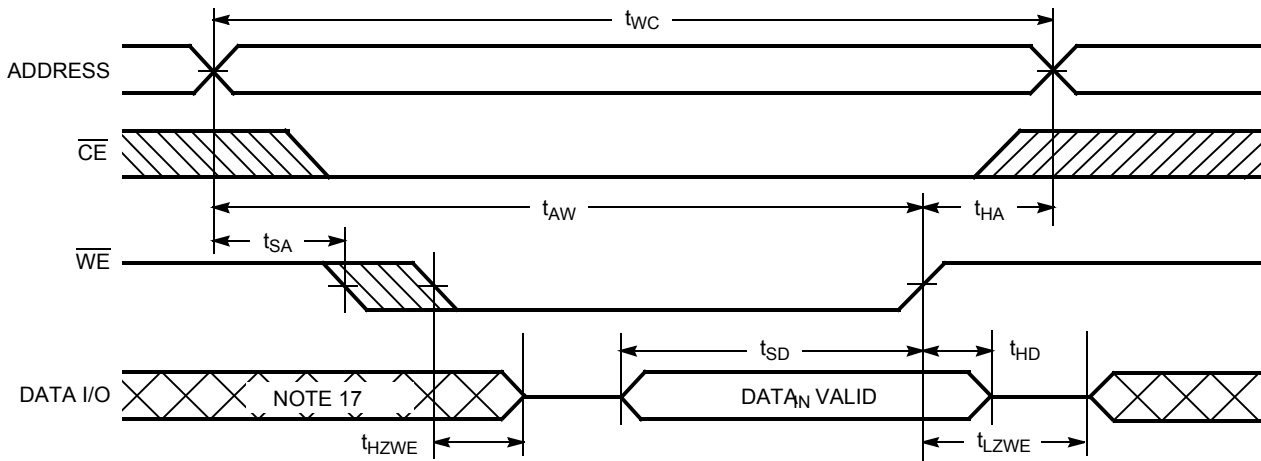

Notes

- 15. If \overline{CE} goes HIGH simultaneously with \overline{WE} HIGH, the output remains in a high-impedance state.
- 16. The minimum write cycle time for Write Cycle No. 3 (\overline{WE} Controlled, \overline{OE} LOW) is the sum of t_{HZWE} and t_{SD} .
- 17. During this period, the I/Os are in output state and input signals should not be applied.

Typical DC and AC Characteristics

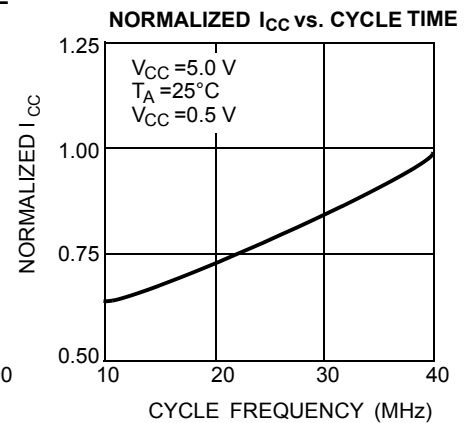
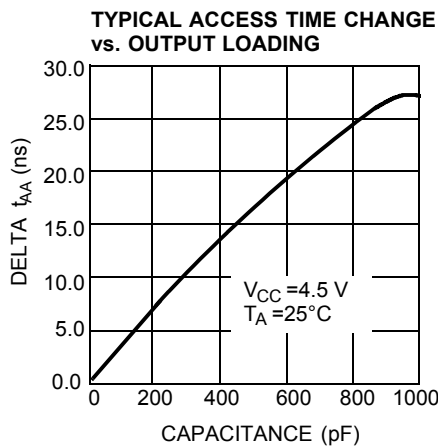
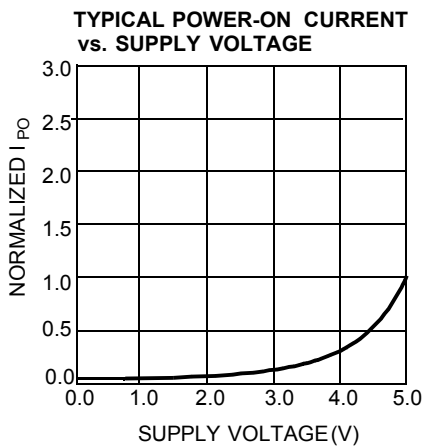
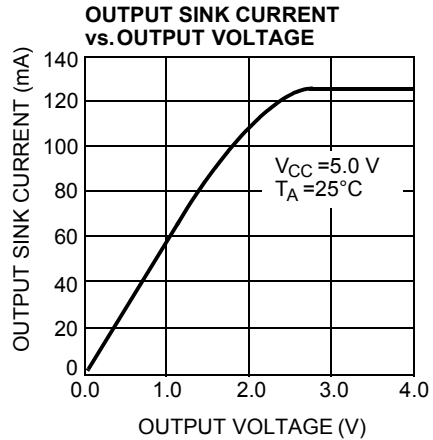
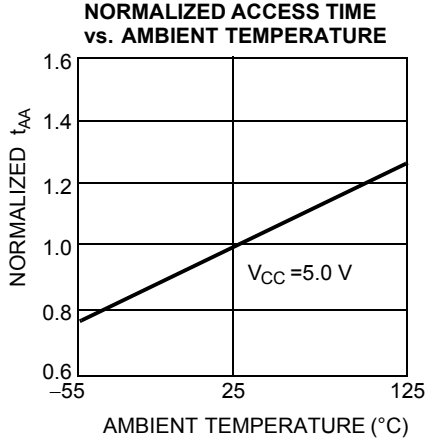
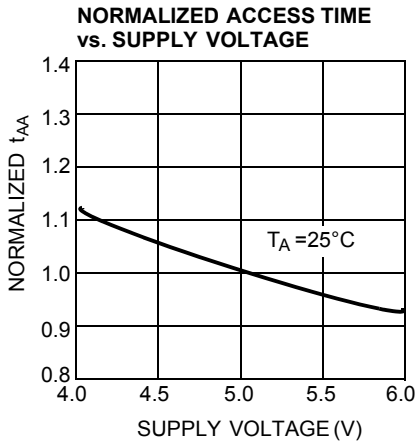
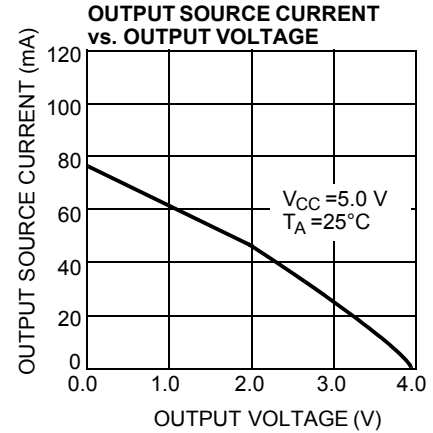
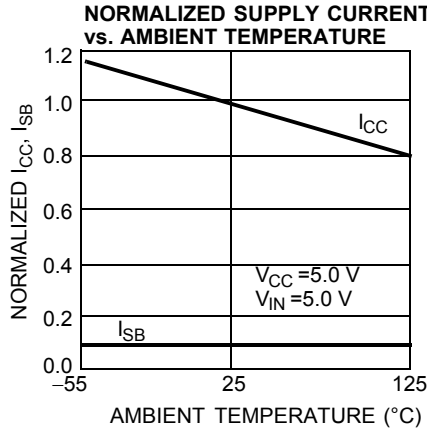
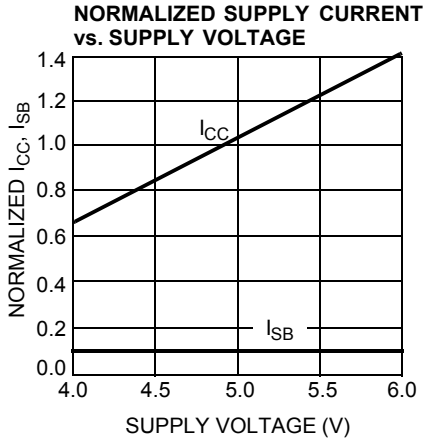

Truth Table

\overline{CE}_1	CE_2	\overline{WE}	\overline{OE}	Input/Output	Mode
H	X	X	X	High Z	Deselect/Power-down
X	L	X	X	High Z	Deselect
L	H	H	L	Data Out	Read
L	H	L	X	Data In	Write
L	H	H	H	High Z	Deselect

Address Designators

Address Name	Address Function	Pin Number
A4	X3	2
A5	X4	3
A6	X5	4
A7	X6	5
A8	X7	6
A9	Y1	7
A10	Y4	8
A11	Y3	9
A12	Y0	10
A0	Y2	21
A1	X0	23
A2	X1	24
A3	X2	25

Ordering Information

Table 1 lists the CY6264 key package features and ordering codes. The table contains only the parts that are currently available. If you do not see what you are looking for, contact your local sales representative. For more information, visit the Cypress website at www.cypress.com and see the product summary page at <http://www.cypress.com/products>.

Table 1. Static RAM Key Features and Ordering Information

Speed (ns)	Ordering Code	Package Diagram	Package Type	Operating Range
55	CY6264-55SNXI	51-85092	28-pin SNC (300 Mils) Narrow Body (Pb-free)	Industrial

Ordering Code Definitions

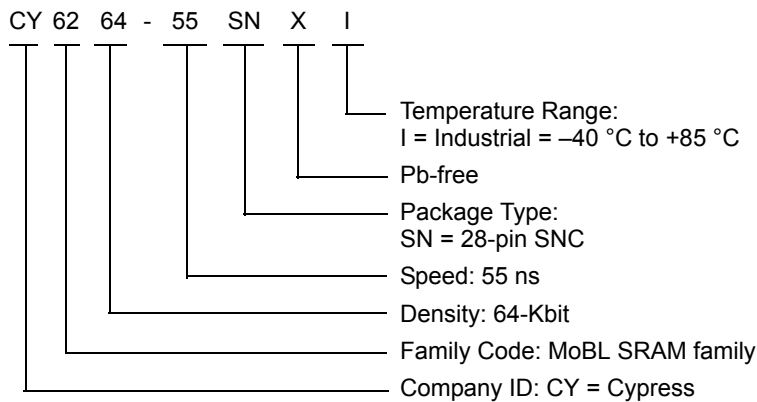

Package Diagram

Figure 8. 28-pin SNC (300 Mils) SN28.3 (Narrow Body) Package Outline, 51-85092

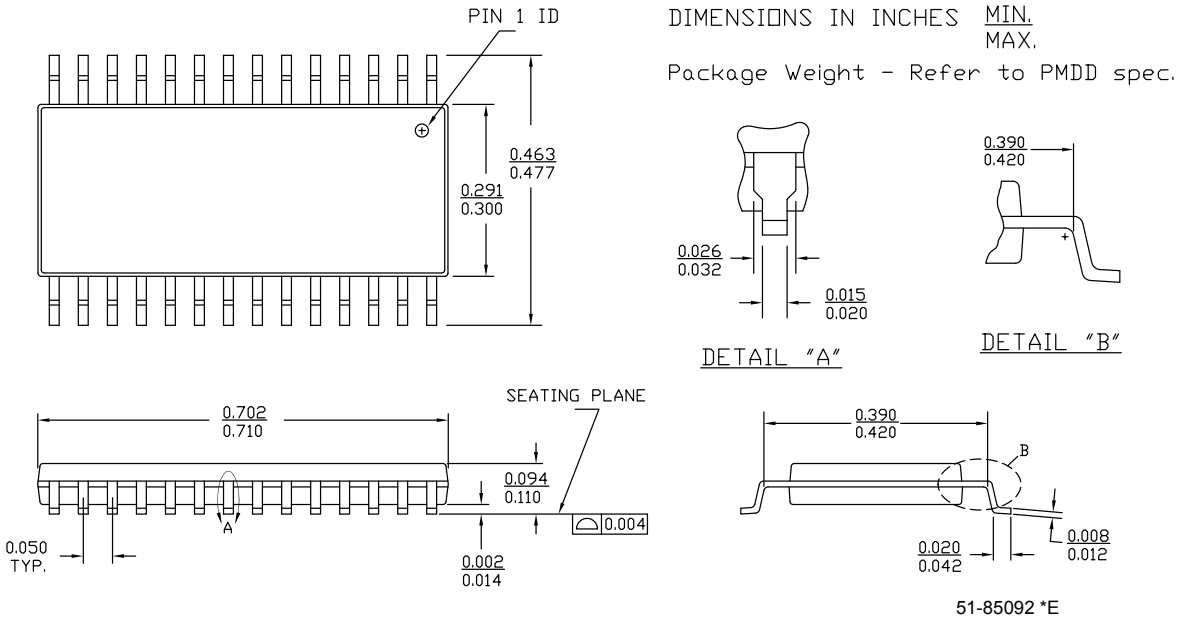

Acronyms

Acronym	Description
CMOS	Complementary Metal Oxide Semiconductor
I/O	Input/Output
SRAM	Static Random Access Memory
TSOP	Thin Small Outline Package
VFBGA	Very Fine-Pitch Ball Grid Array

Document Conventions

Units of Measure

Symbol	Unit of Measure
°C	degrees Celsius
MHz	megahertz
μA	microampere
mA	milliampere
ns	nanosecond
Ω	ohm
pF	picofarad
V	volt
W	watt

Document History Page

Document Title: CY6264, 8K × 8 Static RAM Document Number: 001-02367				
Revision	ECN	Orig. of Change	Submission date	Description of Change
**	384870	PCI	06/28/05	Spec # change from 38-00425 to 001-02367
*A	488954	VKN	See ECN	Added Automotive temperature range related information in all instances across the document. Updated Electrical Characteristics : Changed description of I _{IX} parameter from “Input Load Current” to “Input Leakage Current”. Removed I _{OS} parameter and its details. Updated Ordering Information : Updated part numbers. Replaced “28-pin SOIC” with “28-pin SNC” in “Package Type” column.
*B	2892510	VKN	See ECN	Updated Ordering Information . Updated Package Diagram . Added Sales, Solutions, and Legal Information .
*C	3329873	RAME	07/27/11	Removed “AN1064 - SRAM System Design Guidelines” related information in all instances across the document. Added Ordering Code Definitions under Ordering Information . Added Acronyms , and Units of Measure . Updated to new template.
*D	4122787	VINI	09/13/2013	Updated Package Diagram : spec 51-85092 – Changed revision from *C to *E. Updated to new template. Completing Sunset Review.
*E	4525875	VINI	10/06/2014	Updated Maximum Ratings : Referred Note 1 in “Supply voltage to ground potential”. Updated Switching Characteristics : Added Note 7 and referred the same note in “WRITE CYCLE”. Updated Switching Waveforms : Added Figure 7 . Added Note 15, 16, 17 and referred the same notes in Figure 7 . Completing Sunset Review.
*F	4576406	VINI	01/16/2015	Updated Functional Description : Added “For a complete list of related documentation, click here .” at the end. Updated Ordering Information : Updated part numbers.
*G	5478038	VINI	10/17/2016	Updated Ordering Information : Updated part numbers. Updated to new template. Completing Sunset Review.

Sales, Solutions, and Legal Information

Worldwide Sales and Design Support

Cypress maintains a worldwide network of offices, solution centers, manufacturer's representatives, and distributors. To find the office closest to you, visit us at [Cypress Locations](#).

Products

ARM® Cortex® Microcontrollers	cypress.com/arm
Automotive	cypress.com/automotive
Clocks & Buffers	cypress.com/clocks
Interface	cypress.com/interface
Internet of Things	cypress.com/iot
Lighting & Power Control	cypress.com/powerpsoc
Memory	cypress.com/memory
PSoC	cypress.com/psoc
Touch Sensing	cypress.com/touch
USB Controllers	cypress.com/usb
Wireless/RF	cypress.com/wireless

PSoC® Solutions

[PSoC 1](#) | [PSoC 3](#) | [PSoC 4](#) | [PSoC 5LP](#)

Cypress Developer Community

[Forums](#) | [Projects](#) | [Video](#) | [Blogs](#) | [Training](#) | [Components](#)

Technical Support

cypress.com/support



© Cypress Semiconductor Corporation, 2005-2016. This document is the property of Cypress Semiconductor Corporation and its subsidiaries, including Spansion LLC ("Cypress"). This document, including any software or firmware included or referenced in this document ("Software"), is owned by Cypress under the intellectual property laws and treaties of the United States and other countries worldwide. Cypress reserves all rights under such laws and treaties and does not, except as specifically stated in this paragraph, grant any license under its patents, copyrights, trademarks, or other intellectual property rights. If the Software is not accompanied by a license agreement and you do not otherwise have a written agreement with Cypress governing the use of the Software, then Cypress hereby grants you a personal, non-exclusive, nontransferable license (without the right to sublicense) (1) under its copyright rights in the Software (a) for Software provided in source code form, to modify and reproduce the Software solely for use with Cypress hardware products, only internally within your organization, and (b) to distribute the Software in binary code form externally to end users (either directly or indirectly through resellers and distributors), solely for use on Cypress hardware product units, and (2) under those claims of Cypress's patents that are infringed by the Software (as provided by Cypress, unmodified) to make, use, distribute, and import the Software solely for use with Cypress hardware products. Any other use, reproduction, modification, translation, or compilation of the Software is prohibited.

TO THE EXTENT PERMITTED BY APPLICABLE LAW, CYPRESS MAKES NO WARRANTY OF ANY KIND, EXPRESS OR IMPLIED, WITH REGARD TO THIS DOCUMENT OR ANY SOFTWARE OR ACCOMPANYING HARDWARE, INCLUDING, BUT NOT LIMITED TO, THE IMPLIED WARRANTIES OF MERCHANTABILITY AND FITNESS FOR A PARTICULAR PURPOSE. To the extent permitted by applicable law, Cypress reserves the right to make changes to this document without further notice. Cypress does not assume any liability arising out of the application or use of any product or circuit described in this document. Any information provided in this document, including any sample design information or programming code, is provided only for reference purposes. It is the responsibility of the user of this document to properly design, program, and test the functionality and safety of any application made of this information and any resulting product. Cypress products are not designed, intended, or authorized for use as critical components in systems designed or intended for the operation of weapons, weapons systems, nuclear installations, life-support devices or systems, other medical devices or systems (including resuscitation equipment and surgical implants), pollution control or hazardous substances management, or other uses where the failure of the device or system could cause personal injury, death, or property damage ("Unintended Uses"). A critical component is any component of a device or system whose failure to perform can be reasonably expected to cause the failure of the device or system, or to affect its safety or effectiveness. Cypress is not liable, in whole or in part, and you shall and hereby do release Cypress from any claim, damage, or other liability arising from or related to all Unintended Uses of Cypress products. You shall indemnify and hold Cypress harmless from and against all claims, costs, damages, and other liabilities, including claims for personal injury or death, arising from or related to any Unintended Uses of Cypress products.

Cypress, the Cypress logo, Spansion, the Spansion logo, and combinations thereof, WICED, PSoC, CapSense, EZ-USB, F-RAM, and Traveo are trademarks or registered trademarks of Cypress in the United States and other countries. For a more complete list of Cypress trademarks, visit cypress.com. Other names and brands may be claimed as property of their respective owners.

Looking for pricing, stock, or lifecycle information?

Click below to explore more details on WIN SOURCE:

-  [View CY6264-70SNXC on WIN SOURCE](#)
-  [Cypress Semiconductor Corp Information](#)

Optimize Your Supply Chain with WIN SOURCE Solutions

-  Global Sourcing Solution
-  Obsolete Management
-  Cost Control Management
-  Shortage Management
-  Alternative Solution
-  Excess Inventory Management