



**THE DATASHEET OF
CY62256NLL-70SNXCT**



Features

- Temperature ranges
 - Commercial: 0 °C to +70 °C
 - Industrial: -40 °C to +85 °C
 - Automotive-A: -40 °C to +85 °C
 - Automotive-E: -40 °C to +125 °C
- High speed: 55 ns
- Voltage range: 4.5 V to 5.5 V operation
- Low active power
 - 275 mW (max)
- Low standby power (LL version)
 - 82.5 μW (max)
- Easy memory expansion with \overline{CE} and \overline{OE} Features
- TTL-compatible inputs and outputs
- Automatic power-down when deselected
- CMOS for optimum speed and power
- Available in Pb-free and non Pb-free 28-pin (600-mil) PDIP, 28-pin (300-mil) narrow SOIC, 28-pin TSOP I, and 28-pin reverse TSOP I packages

Functional Description

The CY62256N is a high performance CMOS static RAM organized as 32K words by 8 bits. Easy memory expansion is provided by an active LOW chip enable (\overline{CE}) and active LOW output enable (\overline{OE}) and tristate drivers. This device has an automatic power-down feature, reducing the power consumption by 99.9 percent when deselected.

An active LOW write enable signal (\overline{WE}) controls the writing/reading operation of the memory. When \overline{CE} and \overline{WE} inputs are both LOW, data on the eight data input/output pins (I/O_0 through I/O_7) is written into the memory location addressed by the address present on the address pins (A_0 through A_{14}). Reading the device is accomplished by selecting the device and enabling the outputs, \overline{CE} and \overline{OE} active LOW, while \overline{WE} remains inactive or HIGH. Under these conditions, the contents of the location addressed by the information on address pins are present on the eight data input/output pins.

The input/output pins remain in a high impedance state unless the chip is selected, outputs are enabled, and write enable (\overline{WE}) is HIGH.

For a complete list of related documentation, click [here](#).

Logic Block Diagram

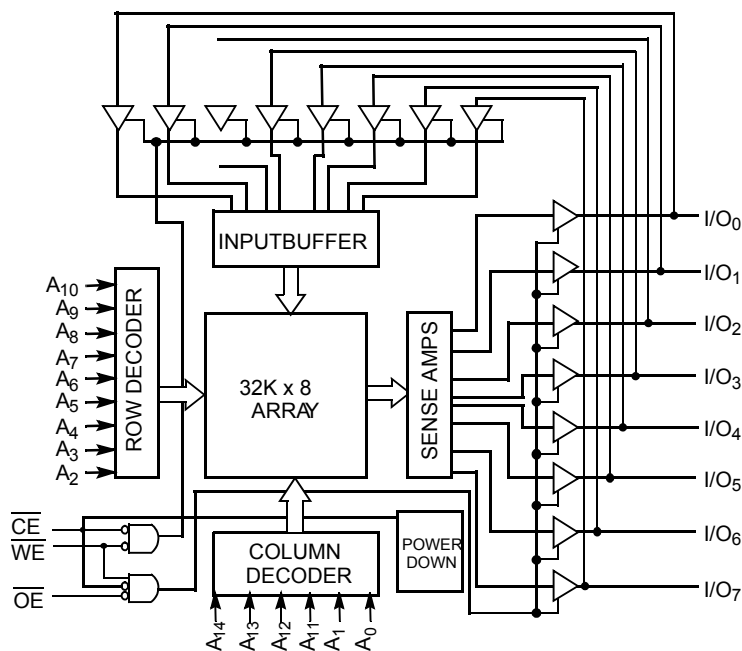

Contents

Product Portfolio	3	Truth Table	11
Pin Configurations	3	Ordering Information	12
Pin Definitions	3	Ordering Code Definitions	12
Maximum Ratings	4	Package Diagrams	13
Operating Range	4	Acronyms	15
Electrical Characteristics	4	Document Conventions	15
Capacitance	5	Units of Measure	15
Thermal Resistance	5	Document History Page	16
AC Test Loads and Waveforms	5	Sales, Solutions, and Legal Information	17
Data Retention Characteristics	6	Worldwide Sales and Design Support	17
Data Retention Waveform	6	Products	17
Switching Characteristics	7	PSoC® Solutions	17
Switching Waveforms	8	Cypress Developer Community	17
Typical DC and AC Characteristics	10	Technical Support	17

Product Portfolio

Product		V _{CC} Range (V)			Speed (ns)	Power Dissipation			
		Min	Typ ^[1]	Max		Operating, I _{CC} (mA)		Standby, I _{SB2} (μA)	
					Typ ^[1]	Max	Typ ^[1]	Max	
CY62256NLL	Commercial	4.5	5.0	5.5	70	25	50	0.1	5
CY62256NLL	Industrial				55/70	25	50	0.1	10
CY62256NLL	Automotive-A				55/70	25	50	0.1	10
CY62256NLL	Automotive-E				55	25	50	0.1	15

Pin Configurations

Figure 1. 28-pin DIP and Narrow SOIC pinout

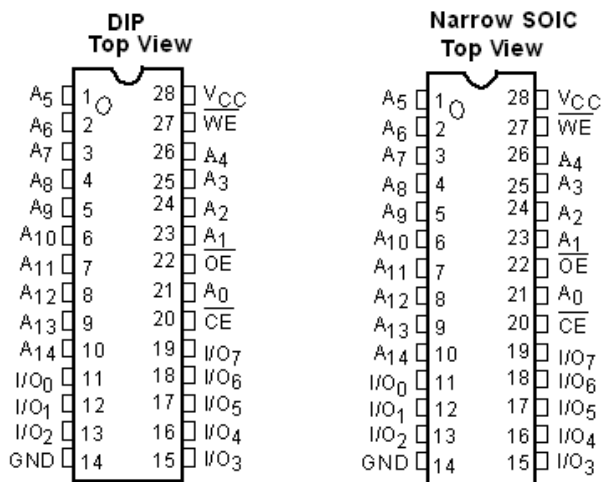
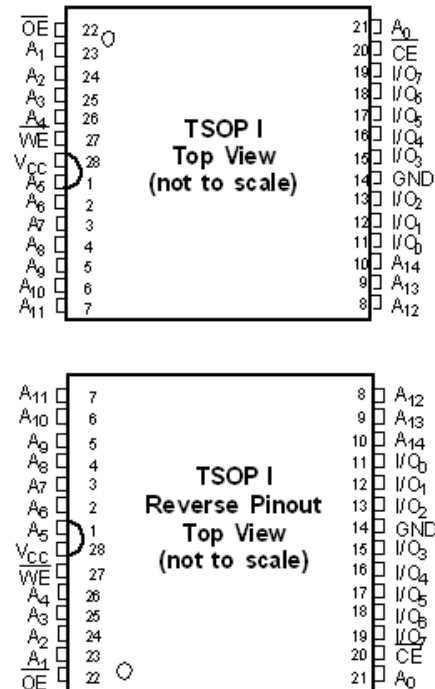

Figure 2. 28-pin TSOP I and Reverse TSOP I pinout



Pin Definitions

Pin Number	Type	Description
1–10, 21, 23–26	Input	A₀–A₁₄ . Address Inputs
11–13, 15–19,	Input/Output	I/O₀–I/O₇ . Data lines. Used as input or output lines depending on operation
27	Input/Control	WE . When selected LOW, a WRITE is conducted. When selected HIGH, a READ is conducted
20	Input/Control	CE . When LOW, selects the chip. When HIGH, deselects the chip
22	Input/Control	OE . Output Enable. Controls the direction of the I/O pins. When LOW, the I/O pins behave as outputs. When deasserted HIGH, I/O pins are tristated, and act as input data pins
14	Ground	GND . Ground for the device
28	Power Supply	V_{CC} . Power supply for the device

Note

1. Typical specifications are the mean values measured over a large sample size across normal production process variations and are taken at nominal conditions (T_A = 25 °C, V_{CC}). Parameters are guaranteed by design and characterization, and not 100% tested.

Maximum Ratings

Exceeding maximum ratings may impair the useful life of the device. These user guidelines are not tested.

Storage temperature -65 °C to +150 °C

Ambient temperature with power applied -55 °C to +125 °C

Supply voltage to ground potential (pin 28 to pin 14) ^[2] -0.5 V to +7.0 V

DC voltage applied to outputs in high Z State ^[2] -0.5 V to V_{CC} + 0.5 V

DC input voltage ^[2] -0.5 V to V_{CC} + 0.5 V

Output current into outputs (LOW) 20 mA

Static discharge voltage (per MIL-STD-883, method 3015) > 2001 V

Latch-up current > 200 mA

Operating Range

Range	Ambient Temperature (T _A) ^[3]	V _{CC}
Commercial	0 °C to +70 °C	5 V ± 10%
Industrial	-40 °C to +85 °C	5 V ± 10%
Automotive-A	-40 °C to +85 °C	5 V ± 10%
Automotive-E	-40 °C to +125 °C	5 V ± 10%

Electrical Characteristics

Over the Operating Range

Parameter	Description	Test Conditions	-55			-70			Unit	
			Min	Typ ^[4]	Max	Min	Typ ^[4]	Max		
V _{OH}	Output HIGH voltage	V _{CC} = Min, I _{OH} = -1.0 mA	2.4	-	-	2.4	-	-	V	
V _{OL}	Output LOW voltage	V _{CC} = Min, I _{OL} = 2.1 mA	-	-	0.4	-	-	0.4	V	
V _{IH}	Input HIGH voltage		2.2	-	V _{CC} + 0.5	2.2	-	V _{CC} + 0.5	V	
V _{IL}	Input LOW voltage		-0.5	-	0.8	-0.5	-	0.8	V	
I _{IX}	Input leakage current	GND ≤ V _I ≤ V _{CC}	-0.5	-	+0.5	-0.5	-	+0.5	μA	
I _{OZ}	Output leakage current	GND ≤ V _O ≤ V _{CC} , output disabled	-0.5	-	+0.5	-0.5	-	+0.5	μA	
I _{CC}	V _{CC} operating supply current	V _{CC} = Max, I _{OUT} = 0 mA, f = f _{MAX} = 1/t _{RC}	LL - Commercial	-	-	-	-	25	50	mA
			LL - Industrial	-	25	50	-	25	50	mA
			LL - Automotive-A	-	25	50	-	25	50	mA
			LL - Automotive-E	-	25	50	-	-	-	mA
I _{SB1}	Automatic CE power-down current – TTL inputs	Max. V _{CC} , CE ≥ V _{IH} , V _{IN} ≥ V _{IH} or V _{IN} ≤ V _{IL} , f = f _{MAX}	LL - Commercial	-	-	-	-	0.3	0.5	mA
			LL - Industrial	-	0.3	0.5	-	0.3	0.5	mA
			LL - Automotive-A	-	0.3	0.5	-	0.3	0.5	mA
			LL - Automotive-E	-	0.3	0.5	-	-	-	mA
I _{SB2}	Automatic CE power-down current – CMOS inputs	Max. V _{CC} , CE ≥ V _{CC} - 0.3 V, V _{IN} ≥ V _{CC} - 0.3 V, or V _{IN} ≤ 0.3 V, f = 0	LL - Commercial	-	-	-	-	0.1	5	μA
			LL - Industrial	-	0.1	10	-	0.1	10	μA
			LL - Automotive-A	-	0.1	10	-	0.1	10	μA
			LL - Automotive-E	-	0.1	15	-	-	-	μA

Notes

- V_{IL} (min) = -2.0 V for pulse durations of less than 20 ns.
- T_A is the "Instant-On" case temperature.
- Typical specifications are the mean values measured over a large sample size across normal production process variations and are taken at nominal conditions (T_A = 25 °C, V_{CC}). Parameters are guaranteed by design and characterization, and not 100% tested.

Capacitance

Parameter ^[5]	Description	Test Conditions	Max	Unit
C_{IN}	Input capacitance	$T_A = 25\text{ }^\circ\text{C}$, $f = 1\text{ MHz}$, $V_{CC} = 5.0\text{ V}$	6	pF
C_{OUT}	Output capacitance		8	pF

Thermal Resistance

Parameter ^[5]	Description	Test Conditions	DIP	SOIC	TSOP	RTSOP	Unit
θ_{JA}	Thermal resistance (junction to ambient)	Still air, soldered on a 4.25×1.125 inch, 4-layer printed circuit board	75.61	76.56	93.89	93.89	$^\circ\text{C/W}$
θ_{JC}	Thermal resistance (junction to case)		43.12	36.07	24.64	24.64	$^\circ\text{C/W}$

AC Test Loads and Waveforms

Figure 3. AC Test Loads and Waveforms

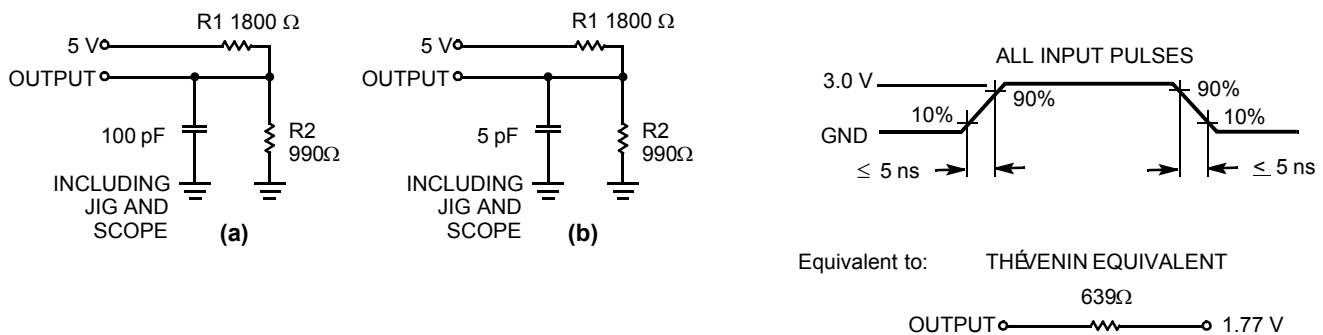

Note

5. Tested initially and after any design or process changes that may affect these parameters.

Data Retention Characteristics

Parameter	Description	Conditions ^[6]	Min	Typ ^[7]	Max	Unit	
V_{DR}	V_{CC} for data retention		2.0	–	–	V	
I_{CCDR}	Data retention current	LL – Commercial	$V_{CC} = 2.0\text{ V}$, $CE \geq V_{CC} - 0.3\text{ V}$, $V_{IN} \geq V_{CC} - 0.3\text{ V}$, or $V_{IN} \leq 0.3\text{ V}$	–	0.1	5	μA
		LL – Industrial/ Automotive-A		–	0.1	10	μA
		LL – Automotive-E		–	0.1	10	μA
$t_{CDR}^{[7]}$	Chip deselect to data retention time		0	–	–	ns	
$t_R^{[7]}$	Operation recovery time	CY62256NLL-55	55	–	–	ns	
		CY62256NLL-70	70	–	–		

Data Retention Waveform

Figure 4. Data Retention Waveform

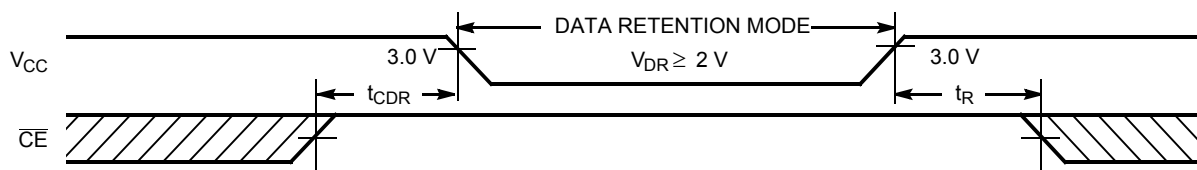

Notes

6. No input may exceed $V_{CC} + 0.5\text{ V}$.
7. Typical specifications are the mean values measured over a large sample size across normal production process variations and are taken at nominal conditions ($T_A = 25\text{ }^\circ\text{C}$, V_{CC}). Parameters are guaranteed by design and characterization, and not 100% tested.

Switching Characteristics

Over the Operating Range

Parameter ^[8]	Description	CY62256N-55		CY62256N-70		Unit
		Min	Max	Min	Max	
Read Cycle						
t_{RC}	Read cycle time	55	–	70	–	ns
t_{AA}	Address to data valid	–	55	–	70	ns
t_{OHA}	Data hold from address change	5	–	5	–	ns
t_{ACE}	\overline{CE} LOW to data valid	–	55	–	70	ns
t_{DOE}	\overline{OE} LOW to data valid	–	25	–	35	ns
t_{LZOE}	\overline{OE} LOW to low Z ^[9]	5	–	5	–	ns
t_{HZOE}	\overline{OE} HIGH to high Z ^[9, 10]	–	20	–	25	ns
t_{LZCE}	\overline{CE} LOW to low Z ^[9]	5	–	5	–	ns
t_{HZCE}	\overline{CE} HIGH to high Z ^[9, 10]	–	20	–	25	ns
t_{PU}	\overline{CE} LOW to power-up	0	–	0	–	ns
t_{PD}	\overline{CE} HIGH to power-down	–	55	–	70	ns
Write Cycle ^[11, 12]						
t_{WC}	Write cycle time	55	–	70	–	ns
t_{SCE}	\overline{CE} LOW to write end	45	–	60	–	ns
t_{AW}	Address setup to write end	45	–	60	–	ns
t_{HA}	Address hold from write end	0	–	0	–	ns
t_{SA}	Address setup to write start	0	–	0	–	ns
t_{PWE}	\overline{WE} pulse width	40	–	50	–	ns
t_{SD}	Data setup to write end	25	–	30	–	ns
t_{HD}	Data hold from write end	0	–	0	–	ns
t_{HZWE}	\overline{WE} LOW to high Z ^[9, 10]	–	20	–	25	ns
t_{LZWE}	\overline{WE} HIGH to low Z ^[9]	5	–	5	–	ns

Notes

8. Test conditions assume signal transition time of 5 ns or less, timing reference levels of 1.5 V, input pulse levels of 0 to 3.0 V, and output loading of the specified I_{OL}/I_{OH} and 100-pF load capacitance.
9. At any temperature and voltage condition, t_{HZCE} is less than t_{LZCE} , t_{HZOE} is less than t_{LZOE} , and t_{HZWE} is less than t_{LZWE} for any device.
10. t_{HZOE} , t_{HZCE} , and t_{HZWE} are specified with $C_L = 5$ pF as in (b) of AC Test Loads. Transition is measured ± 500 mV from steady-state voltage.
11. The internal Write time of the memory is defined by the overlap of \overline{CE} LOW and \overline{WE} LOW. Both signals must be LOW to initiate a Write and either signal can terminate a Write by going HIGH. The data input setup and hold timing should be referenced to the rising edge of the signal that terminates the Write.
12. The minimum write cycle time for Write Cycle No. 3 (\overline{WE} Controlled, \overline{OE} LOW) is the sum of t_{HZWE} and t_{SD} .

Switching Waveforms

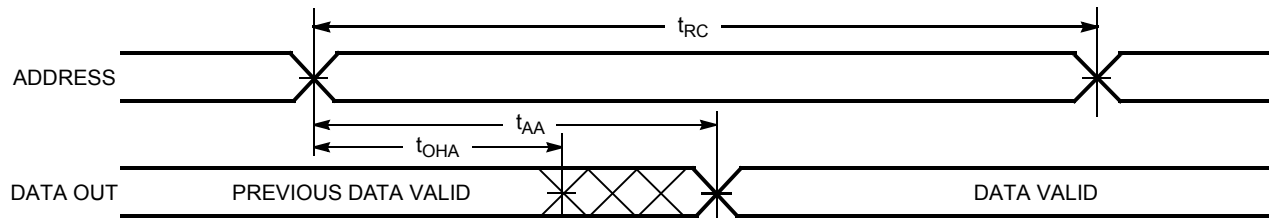
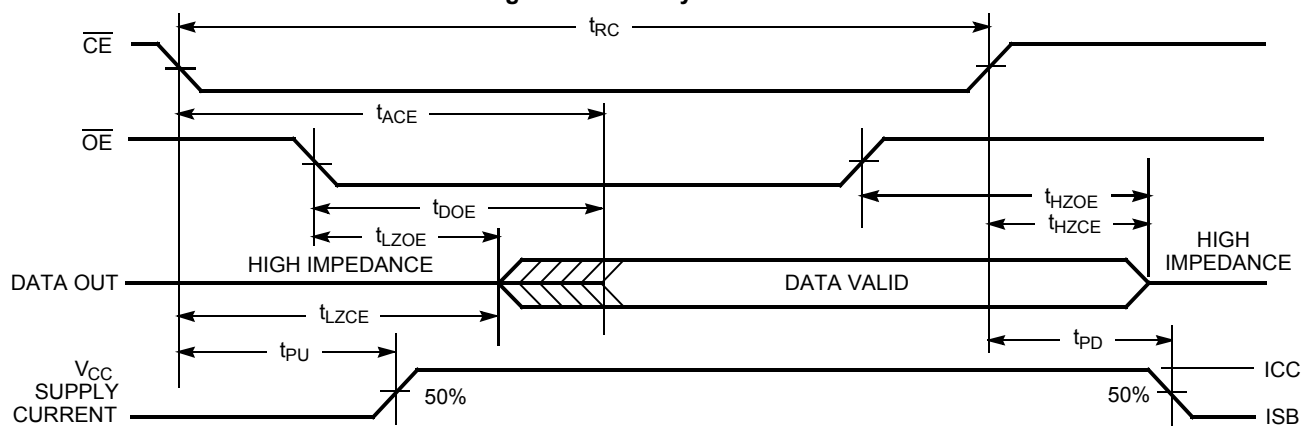
Figure 5. Read Cycle No. 1 [13, 14]

Figure 6. Read Cycle No. 2 [14, 15]

Notes

13. Device is continuously selected. $\overline{OE}, \overline{CE} = V_{IL}$.
14. \overline{WE} is HIGH for Read cycle.
15. Address valid prior to or coincident with \overline{CE} transition LOW.

Switching Waveforms (continued)

Figure 7. Write Cycle No. 1 (\overline{WE} Controlled) [16, 17, 18]

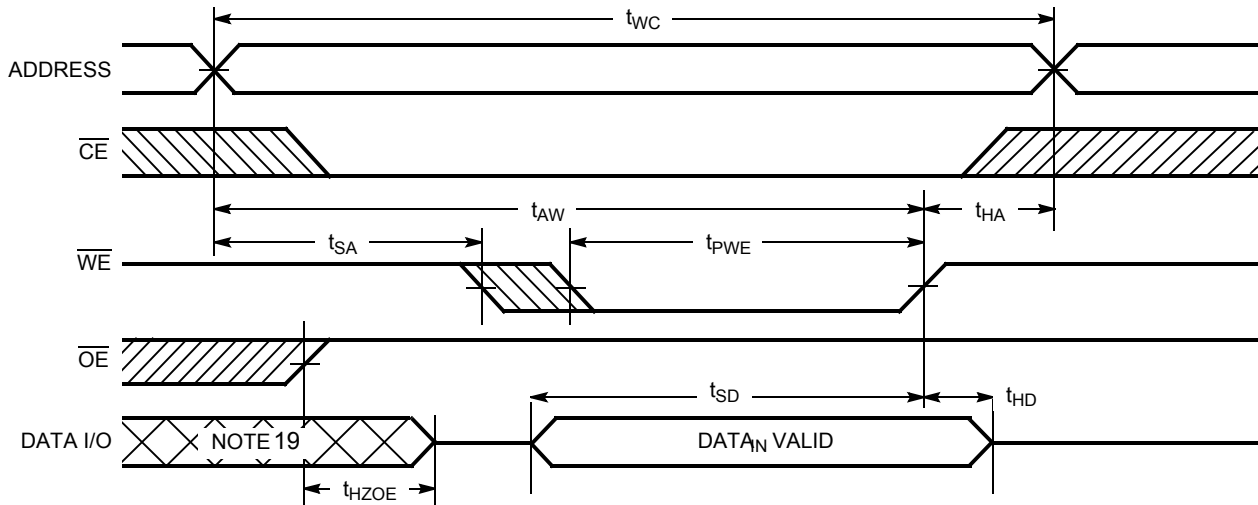

Figure 8. Write Cycle No. 2 (\overline{CE} Controlled) [16, 17, 18]

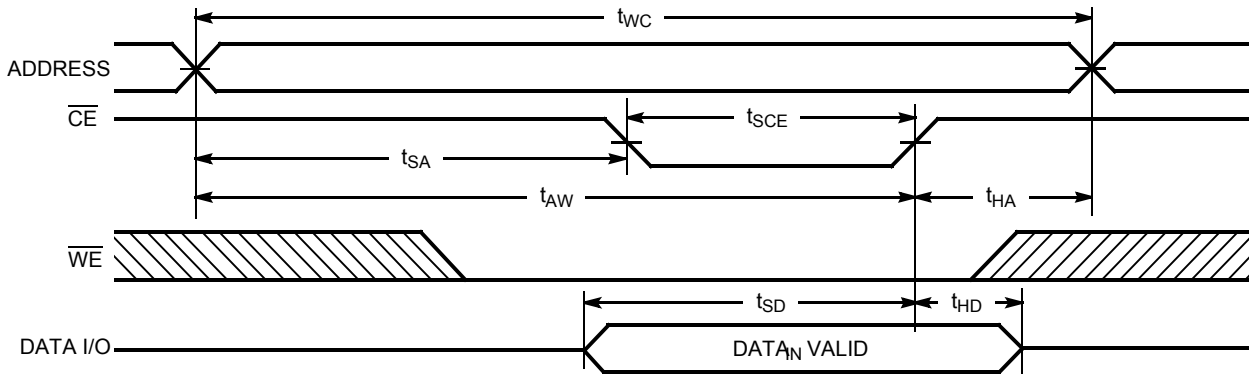
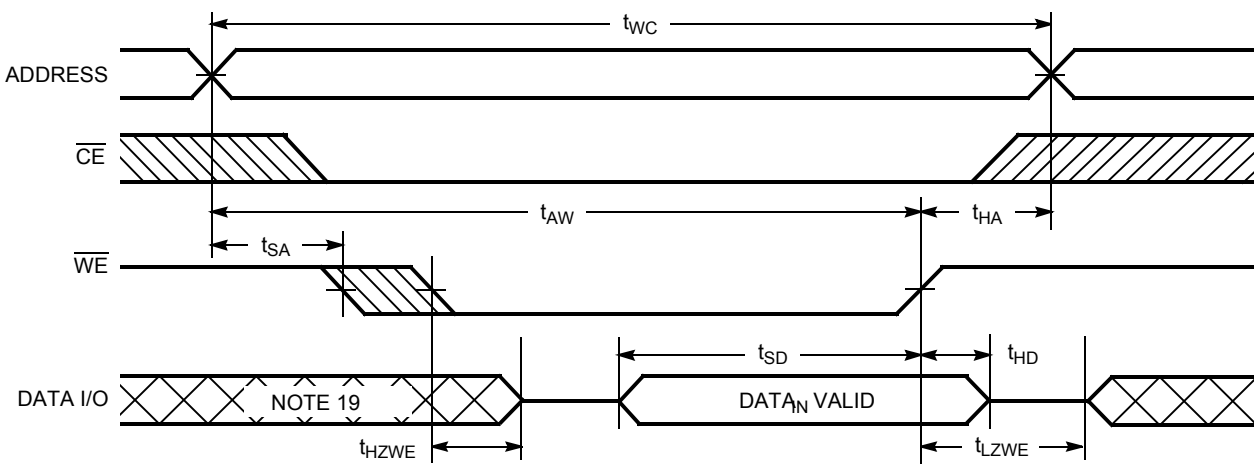

Figure 9. Write Cycle No. 3 (\overline{WE} Controlled, \overline{OE} LOW) [18, 20]



Notes

16. The internal Write time of the memory is defined by the overlap of \overline{CE} LOW and \overline{WE} LOW. Both signals must be LOW to initiate a Write and either signal can terminate a Write by going HIGH. The data input setup and hold timing should be referenced to the rising edge of the signal that terminates the Write.
17. Data I/O is high impedance if $OE = V_{IH}$.
18. If \overline{CE} goes HIGH simultaneously with \overline{WE} HIGH, the output remains in a high-impedance state.
19. During this period, the I/Os are in output state and input signals should not be applied.
20. The minimum write cycle pulse width should be equal to the sum of t_{SD} and t_{HZWE} .

Typical DC and AC Characteristics

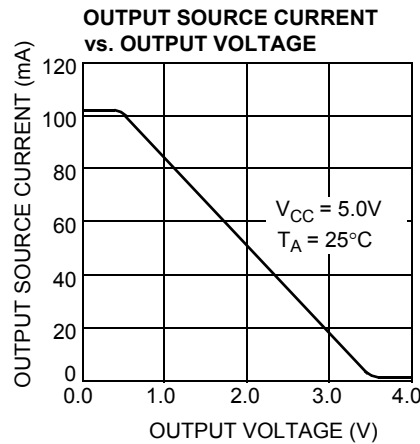
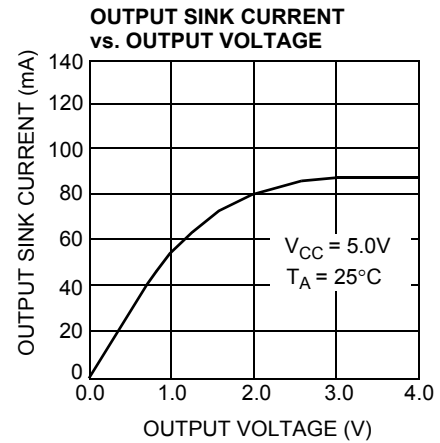
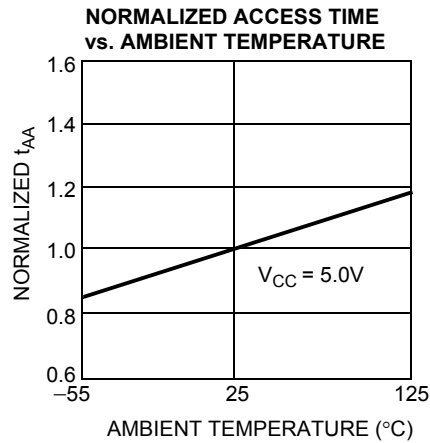
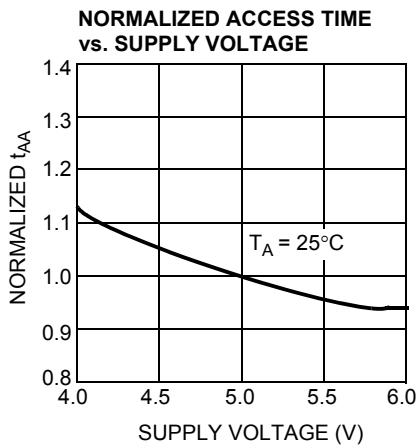
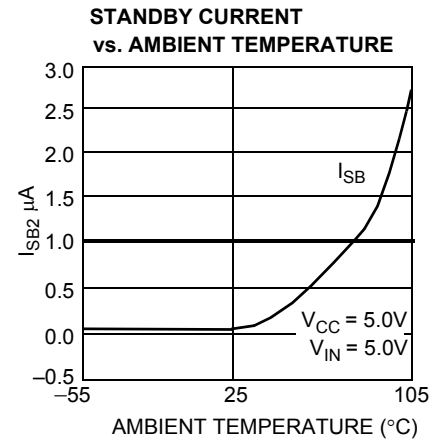
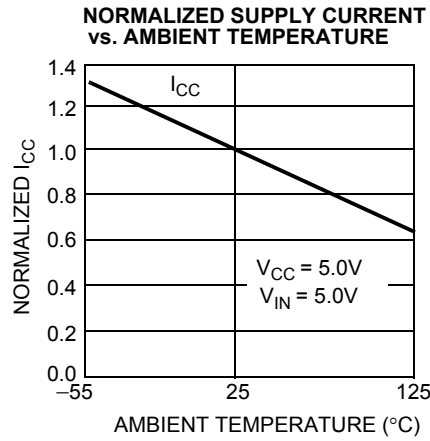
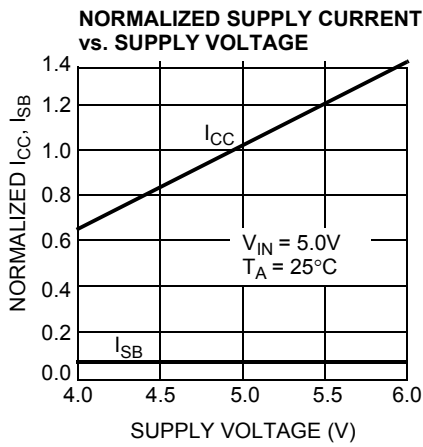

Typical DC and AC Characteristics (continued)

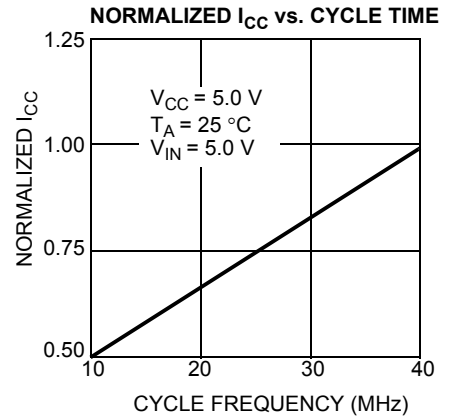
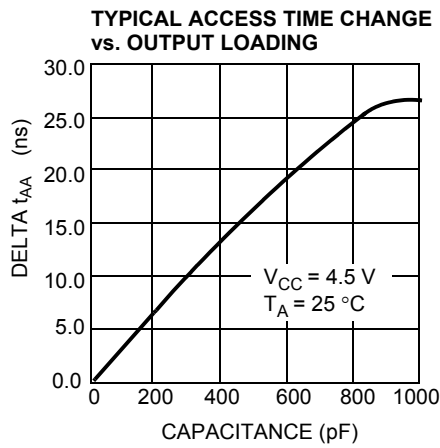
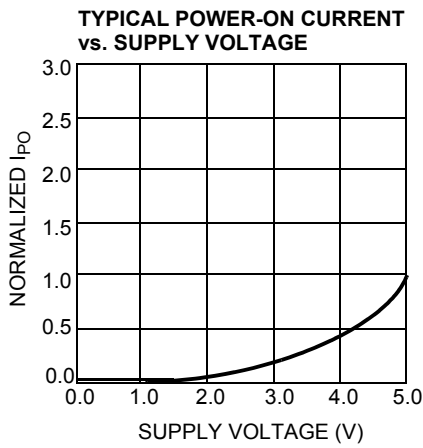

Truth Table

$\overline{\text{CE}}$	$\overline{\text{WE}}$	$\overline{\text{OE}}$	Inputs/Outputs	Mode	Power
H	X	X	High Z	Deselect/power-down	Standby (I _{SB})
L	H	L	Data Out	Read	Active (I _{CC})
L	L	X	Data In	Write	Active (I _{CC})
L	H	H	High Z	Output Disabled	Active (I _{CC})

Ordering Information

Speed (ns)	Ordering Code	Package Diagram	Package Type	Operating Range
55	CY62256NLL-55SNXI	51-85092	28-pin SNC (300 Mils) Narrow Body (Pb-free)	Industrial
	CY62256NLL-55ZXI	51-85071	28-pin TSOP I (Pb-free)	
	CY62256NLL-55ZXAX	51-85071	28-pin TSOP I (Pb-free)	Automotive-A
	CY62256NLL-55SNXE	51-85092	28-pin SNC (300 Mils) Narrow Body (Pb-free)	Automotive-E
	CY62256NLL-55ZXEX	51-85071	28-pin TSOP I (Pb-free)	
70	CY62256NLL-70PXC	51-85017	28-pin (600 Mil) Molded DIP (Pb-free)	Commercial
	CY62256NLL-70SNXC	51-85092	28-pin SNC (300 Mils) Narrow Body (Pb-free)	
	CY62256NLL-70ZRXI	51-85074	28-pin Reverse TSOP I (Pb-free)	Industrial
	CY62256NLL-70SNXA	51-85092	28-pin SNC (300 Mils) Narrow Body (Pb-free)	Automotive-A

Ordering Code Definitions

CY 62 256 N LL - XX XXX X

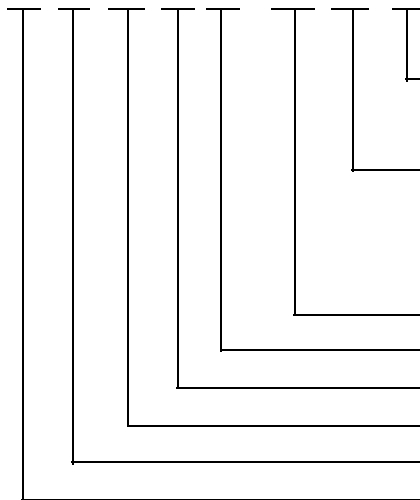

- Temperature Grade: X = C or I or A or E
 C = Commercial = 0 °C to +70 °C; I = Industrial = -40 °C to +85 °C;
 A = Automotive-A = -40 °C to +85 °C; E = Automotive-E = -40 °C to +125 °C
- Package Type: XXX = SNX or ZX or PX or ZRX
 SNX = 28-pin SNC (Pb-free)
 ZX = 28-pin TSOP I (Pb-free)
 PX = 28-pin Molded DIP (Pb-free)
 ZRX = 28-pin Reverse TSOP I (Pb-free)
- Speed Grade: XX = 55 ns or 70 ns
- Low Power
- Nitride Seal Mask fix
- Density: 256 kbit
- Family Code: MoBL SRAM family
- Company ID: CY = Cypress

Package Diagrams

Figure 10. 28-pin PDIP (1.480 × 0.550 × 0.195 Inches) P28.6/PZ28.6 Package Outline, 51-85017

28 Lead (600 Mil) PDIP – P15

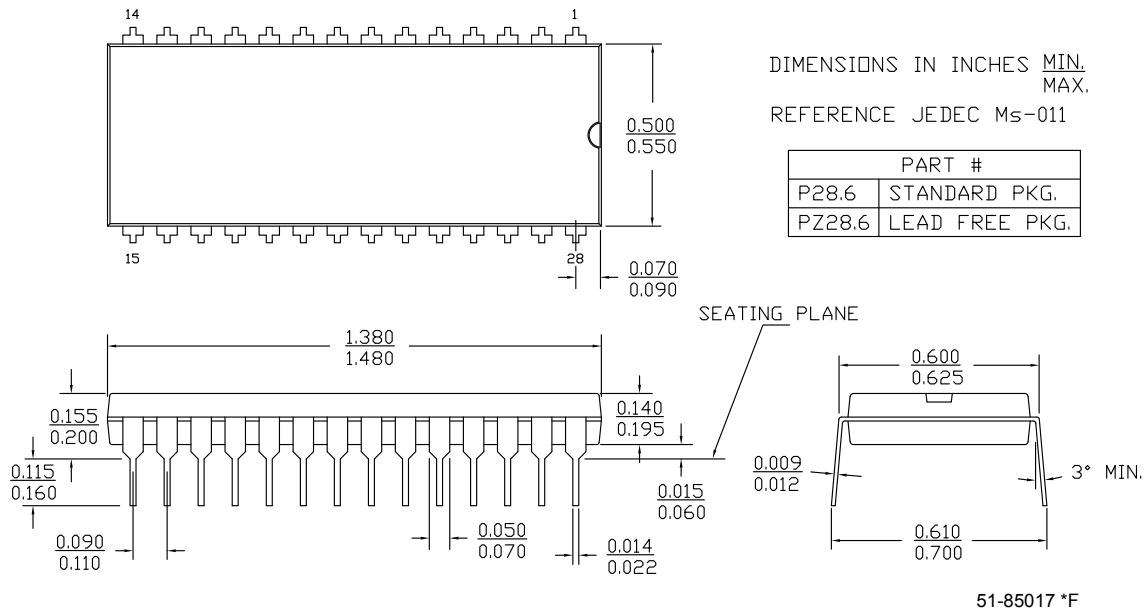
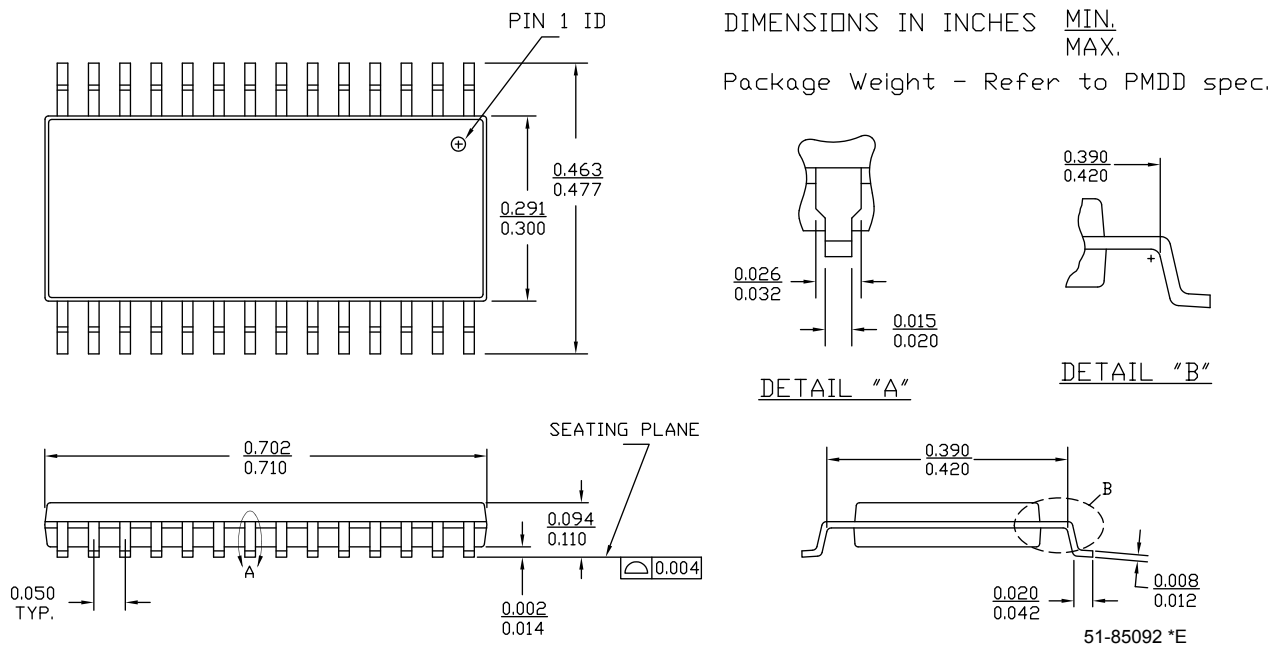

Figure 11. 28-pin SNC (300 Mils) SN28.3 (Narrow Body) Package Outline, 51-85092



Package Diagrams (continued)

Figure 12. 28-pin TSOP I (8 × 13.4 × 1.2 mm) Z28 (Standard) Package Outline, 51-85071

NOTE: ORIENTATION I.D. MAY BE LOCATED EITHER AS SHOWN IN OPTION 1 OR OPTION 2

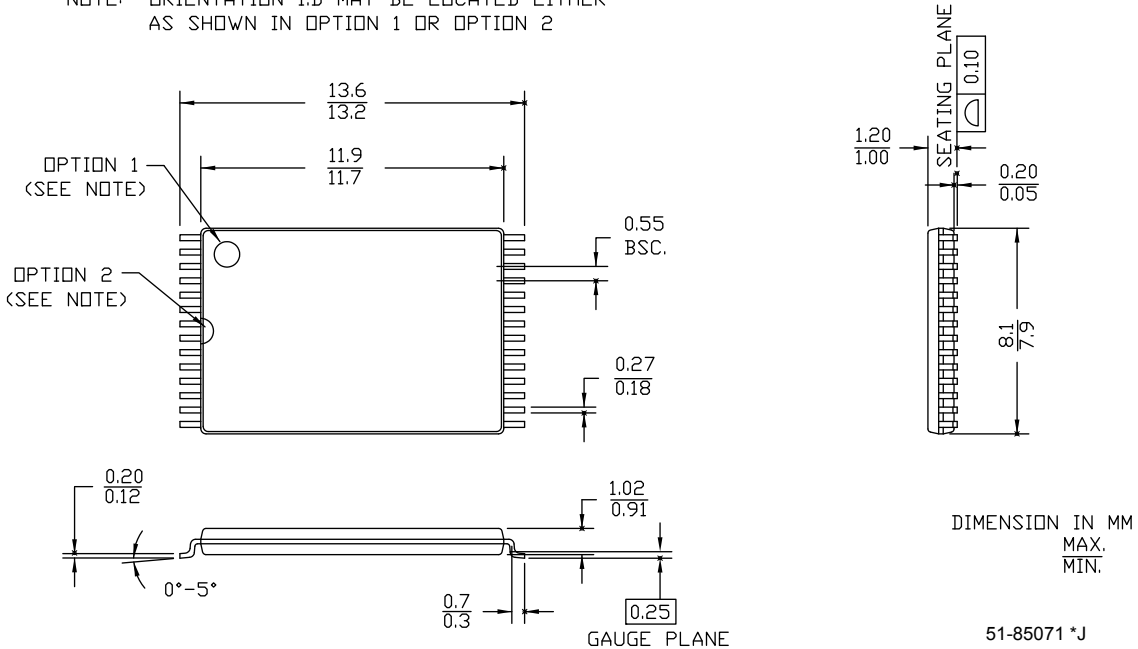
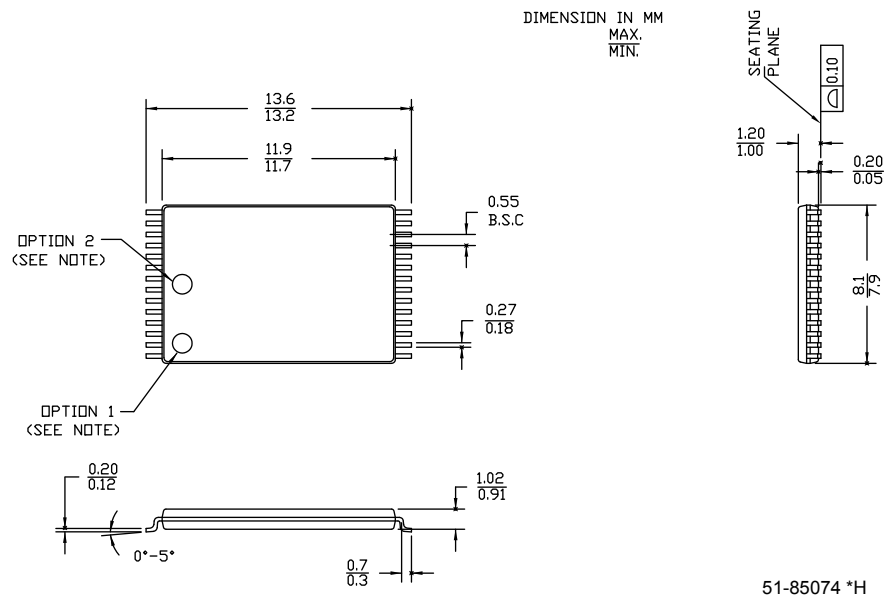

Figure 13. 28-pin TSOP I (8 × 13.4 mm) Package Outline - Reverse, 51-85074

NOTE: ORIENTATION I.D. MAY BE LOCATED EITHER AS SHOWN IN OPTION 1 OR OPTION 2



Acronyms

Acronym	Description
CMOS	Complementary Metal Oxide Semiconductor
I/O	Input/Output
SRAM	Static Random Access Memory
TSOP	Thin Small Outline Package
VFBGA	Very Fine-Pitch Ball Grid Array

Document Conventions

Units of Measure

Symbol	Unit of Measure
°C	degree Celsius
μA	microampere
mA	milliampere
MHz	megahertz
ns	nanosecond
Ω	ohm
pF	picofarad
V	volt
W	watt

Document History Page

Document Title: CY62256N, 256-Kbit (32 K × 8) Static RAM Document Number: 001-06511				
Revision	ECN	Orig. of Change	Submission Date	Description of Change
**	426504	NXR	See ECN	New data sheet.
*A	488954	NXR	See ECN	Added Automotive product Updated ordering Information table
*B	2715270	VKN / AESA	06/05/2009	Updated POD of 28-Pin (600-Mil) Molded DIP package (Spec# 51-85017)
*C	2891344	VKN	03/12/2010	Added Table of Contents Removed "L" product information Updated Ordering Information table Updated Package Diagrams (Figure 10, Figure 11, and Figure 12) Updated Sales, Solutions, and Legal Information
*D	3119519	AJU	01/04/2011	Updated Ordering Information . Added Ordering Code Definitions .
*E	3329873	RAME	07/27/11	Updated template and styles according to current Cypress standards. Added acronyms and units. Removed reference to AN1064 SRAM system guidelines. Updated operation recovery time parameter under Data Retention Characteristics on page 6 .
*F	3433878	TAVA	11/09/11	Updated Package Diagrams .
*G	4122787	VINI	09/13/2013	Updated Package Diagrams : spec 51-85092 – Changed revision from *D to *E. Updated in new template. Completing Sunset Review.
*H	4525875	VINI	10/06/2014	Updated Maximum Ratings : Referred Note 2 in "Supply voltage to ground potential (pin 28 to pin 14)". Updated Package Diagrams : spec 51-85071 – Changed revision from *I to *J. spec 51-85074 – Changed revision from *G to *H. Completing Sunset Review.
*I	4576406	VINI	01/16/2015	Added related documentation hyperlink in page 1. Added Note 12 in Switching Characteristics . Added note reference 12 in the Switching Characteristics table. Added Note 20 in Switching Waveforms . Added note reference 20 in Figure 9 . Updated Figure 10 in Package Diagrams (spec 51-85017 *E to *F).
*J	5718683	AESATMP7	04/28/2017	Updated Cypress Logo and Copyright.

Sales, Solutions, and Legal Information

Worldwide Sales and Design Support

Cypress maintains a worldwide network of offices, solution centers, manufacturer's representatives, and distributors. To find the office closest to you, visit us at [Cypress Locations](#).

Products

Automotive	cypress.com/go/automotive
Clocks & Buffers	cypress.com/go/clocks
Interface	cypress.com/go/interface
Lighting & Power Control	cypress.com/go/powerpsoc
Memory	cypress.com/go/memory
PSoC	cypress.com/go/psoc
Touch Sensing	cypress.com/go/touch
USB Controllers	cypress.com/go/USB
Wireless/RF	cypress.com/go/wireless

PSoC® Solutions

psoc.cypress.com/solutions
PSoC 1 | PSoC 3 | PSoC 4 | PSoC 5LP | PSoC 6

Cypress Developer Community

[Community](#) | [Forums](#) | [Blogs](#) | [Video](#) | [Training](#)

Technical Support

cypress.com/go/support

© Cypress Semiconductor Corporation, 2006-2017. This document is the property of Cypress Semiconductor Corporation and its subsidiaries, including Spansion LLC ("Cypress"). This document, including any software or firmware included or referenced in this document ("Software"), is owned by Cypress under the intellectual property laws and treaties of the United States and other countries worldwide. Cypress reserves all rights under such laws and treaties and does not, except as specifically stated in this paragraph, grant any license under its patents, copyrights, trademarks, or other intellectual property rights. If the Software is not accompanied by a license agreement and you do not otherwise have a written agreement with Cypress governing the use of the Software, then Cypress hereby grants you a personal, non-exclusive, nontransferable license (without the right to sublicense) (1) under its copyright rights in the Software (a) for Software provided in source code form, to modify and reproduce the Software solely for use with Cypress hardware products, only internally within your organization, and (b) to distribute the Software in binary code form externally to end users (either directly or indirectly through resellers and distributors), solely for use on Cypress hardware product units, and (2) under those claims of Cypress's patents that are infringed by the Software (as provided by Cypress, unmodified) to make, use, distribute, and import the Software solely for use with Cypress hardware products. Any other use, reproduction, modification, translation, or compilation of the Software is prohibited.

TO THE EXTENT PERMITTED BY APPLICABLE LAW, CYPRESS MAKES NO WARRANTY OF ANY KIND, EXPRESS OR IMPLIED, WITH REGARD TO THIS DOCUMENT OR ANY SOFTWARE OR ACCOMPANYING HARDWARE, INCLUDING, BUT NOT LIMITED TO, THE IMPLIED WARRANTIES OF MERCHANTABILITY AND FITNESS FOR A PARTICULAR PURPOSE. To the extent permitted by applicable law, Cypress reserves the right to make changes to this document without further notice. Cypress does not assume any liability arising out of the application or use of any product or circuit described in this document. Any information provided in this document, including any sample design information or programming code, is provided only for reference purposes. It is the responsibility of the user of this document to properly design, program, and test the functionality and safety of any application made of this information and any resulting product. Cypress products are not designed, intended, or authorized for use as critical components in systems designed or intended for the operation of weapons, weapons systems, nuclear installations, life-support devices or systems, other medical devices or systems (including resuscitation equipment and surgical implants), pollution control or hazardous substances management, or other uses where the failure of the device or system could cause personal injury, death, or property damage ("Unintended Uses"). A critical component is any component of a device or system whose failure to perform can be reasonably expected to cause the failure of the device or system, or to affect its safety or effectiveness. Cypress is not liable, in whole or in part, and you shall and hereby do release Cypress from any claim, damage, or other liability arising from or related to all Unintended Uses of Cypress products. You shall indemnify and hold Cypress harmless from and against all claims, costs, damages, and other liabilities, including claims for personal injury or death, arising from or related to any Unintended Uses of Cypress products.

Cypress, the Cypress logo, Spansion, the Spansion logo, and combinations thereof, WICED, PSoC, CapSense, EZ-USB, F-RAM, and Traveo are trademarks or registered trademarks of Cypress in the United States and other countries. For a more complete list of Cypress trademarks, visit cypress.com. Other names and brands may be claimed as property of their respective owners.

Looking for pricing, stock, or lifecycle information?

Click below to explore more details on WIN SOURCE:

 [View CY62256NLL-70SNXCT on WIN SOURCE](#)

 [Cypress Semiconductor Corp](#) Information

Optimize Your Supply Chain with WIN SOURCE Solutions

-  Global Sourcing Solution
-  Obsolete Management
-  Cost Control Management
-  Shortage Management
-  Alternative Solution
-  Excess Inventory Management