

ISO773x-Q1 High-Speed, Robust-EMC Reinforced Triple-Channel Digital Isolators

1 Features

- Qualified for automotive applications
- AEC-Q100 Qualified with the following results:
 - Device temperature grade 1: -40°C to $+125^{\circ}\text{C}$ ambient operating temperature
- **Functional Safety-Capable**
 - Documentation available to aid functional safety system design: [ISO7730-Q1](#), [ISO7731-Q1](#)
- 100 Mbps data rate
- Robust isolation barrier:
 - >100-year projected lifetime at 1500 V_{RMS} working voltage
 - Up to 5000 V_{RMS} isolation rating
 - Up to 12.8 kV surge capability
 - ± 100 kV/ μs typical CMTI
- Wide supply range: 2.25 V to 5.5 V
- 2.25-V to 5.5-V Level translation
- Default output *high* (ISO773x) and *low* (ISO773xF) options
- Low power consumption, typical 1.5 mA per channel at 1 Mbps
- Low propagation delay: 11 ns Typical (5-V Supplies)
- Robust electromagnetic compatibility (EMC)
 - System-level ESD, EFT, and surge immunity
 - ± 8 kV IEC 61000-4-2 contact discharge protection across isolation barrier
 - Low emissions
- Wide-SOIC (DW-16) and QSOP (DBQ-16) package options
- Safety-related certifications:
 - DIN VDE V 0884-11:2017-01
 - UL 1577 component recognition program
 - CSA, CQC and TUV certifications

2 Applications

- **Hybrid, electric and power train system (EV/HEV)**
 - **Battery management system (BMS)**
 - **On-board charger**
 - **Traction inverter**
 - **DC/DC converter**
 - **Inverter and motor control**

3 Description

The ISO773x-Q1 devices are high-performance, triple-channel digital isolators with 5000 V_{RMS} (DW package) and 3000 V_{RMS} (DBQ package) isolation ratings per UL 1577.

This family includes devices with reinforced insulation ratings according to VDE, CSA, TUV and CQC.

The ISO773x-Q1 family of devices provides high electromagnetic immunity and low emissions at low power consumption, while isolating CMOS or LVCMOS digital I/Os. Each isolation channel has a logic input and output buffer separated by a double capacitive silicon dioxide (SiO₂) insulation barrier. This device comes with enable pins which can be used to put the respective outputs in high impedance for multi-master driving applications and to reduce power consumption.

Device Information

PART NUMBER ⁽¹⁾	PACKAGE	BODY SIZE (NOM)
ISO7730-Q1	SOIC (DW)	10.30 mm × 7.50 mm
ISO7731-Q1	SSOP (DBQ)	4.90 mm × 3.90 mm

(1) For all available packages, see the orderable addendum at the end of the datasheet.

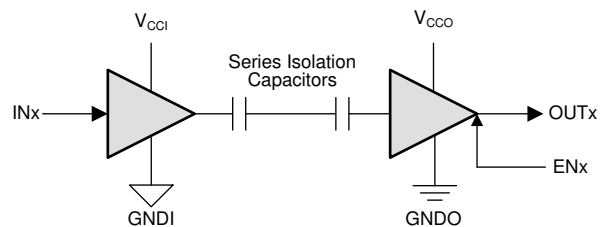

Copyright © 2016, Texas Instruments Incorporated

V_{CCI}=Input supply, V_{CCO}=Output supply
 GNDI=Input ground, GNDO=Output ground

Simplified Schematic



Table of Contents

1 Features	1	7.19 Typical Characteristics.....	18
2 Applications	1	8 Parameter Measurement Information	20
3 Description	1	9 Detailed Description	22
4 Revision History	2	9.1 Overview.....	22
5 Description Continued	4	9.2 Functional Block Diagram.....	22
6 Pin Configuration and Functions	5	9.3 Feature Description.....	23
7 Specifications	7	9.4 Device Functional Modes.....	24
7.1 Absolute Maximum Ratings.....	7	10 Application and Implementation	25
7.2 ESD Ratings.....	7	10.1 Application Information.....	25
7.3 Recommended Operating Conditions.....	7	10.2 Typical Application.....	25
7.4 Thermal Information.....	8	11 Power Supply Recommendations	29
7.5 Power Ratings.....	8	12 Layout	30
7.6 Insulation Specifications.....	9	12.1 Layout Guidelines.....	30
7.7 Safety-Related Certifications.....	10	12.2 Layout Example.....	30
7.8 Safety Limiting Values.....	10	13 Device and Documentation Support	31
7.9 Electrical Characteristics—5-V Supply.....	11	13.1 Documentation Support.....	31
7.10 Supply Current Characteristics—5-V Supply.....	11	13.2 Related Links.....	31
7.11 Electrical Characteristics—3.3-V Supply.....	13	13.3 Receiving Notification of Documentation Updates.....	31
7.12 Supply Current Characteristics—3.3-V Supply.....	13	13.4 Support Resources.....	31
7.13 Electrical Characteristics—2.5-V Supply.....	14	13.5 Trademarks.....	31
7.14 Supply Current Characteristics—2.5-V Supply.....	14	13.6 Electrostatic Discharge Caution.....	31
7.15 Switching Characteristics—5-V Supply.....	15	13.7 Glossary.....	31
7.16 Switching Characteristics—3.3-V Supply.....	16	14 Mechanical, Packaging, and Orderable Information	32
7.17 Switching Characteristics—2.5-V Supply.....	16		
7.18 Insulation Characteristics Curves.....	17		

4 Revision History

NOTE: Page numbers for previous revisions may differ from page numbers in the current version.

Changes from Revision C (March 2020) to Revision D (October 2020) Page

- Added Functional Safety bullets in [Section 1](#) 1

Changes from Revision B (September 2018) to Revision C (March 2020) Page

- Made editorial and cosmetic changes throughout the document 1
- Changed From: "Isolation Barrier Life: >40 Years" To: ">100-year projected lifetime at 1500 V_{RMS} working voltage" in [Section 1](#) 1
- Added "Up to 5000 V_{RMS} isolation rating" in [Section 1](#) 1
- Added "Up to 12.8 kV surge capability" in [Section 1](#) 1
- Added "±8 kV IEC 61000-4-2 contact discharge protection across isolation barrier" in [Section 1](#) 1
- Changed UL certification bullet From: "5000 V_{RMS} (DW) and 2500 V_{RMS} (DBQ) Isolation Rating per UL 1577" To: "UL 1577 component recognition program" in [Section 1](#) 1
- Deleted "All Certifications Complete except CQC Approval of DBQ-16 Package Devices" bullet in [Section 1](#) . 1
- Updated list of applications in [Section 2](#) section..... 1
- Updated [Figure 3-1](#) to show two isolation capacitors in series per channel instead of a single isolation capacitor 1
- Added "Contact discharge per IEC 61000-4-2" specification of ±8000 V in [Section 7.2](#) table..... 7
- Added the following table note to *Data rate* specification in [Section 7.3](#) table: "100 Mbps is the maximum specified data rate, although higher data rates are possible." 7
- Changed V_{IORM} value for DW-16 package From: "1414 V_{PK}" To: "2121 V_{PK}" in [Section 7.6](#) table 9

• Changed V_{IOWM} value for DW-16 package AC voltage From: "1000 V_{RMS} " To: "1500 V_{RMS} " and DC voltage From: "1414 V_{DC} " To: "2121 V_{DC} " in Section 7.6 table	9
• Added 'see Figure 10-8 ' to TEST CONDITIONS of V_{IOWM} specification in Section 7.6	9
• Changed V_{IOSM} TEST CONDITIONS From: "Test method per IEC 60065" To: "Test method per IEC 62368-1" in Section 7.6 table.....	9
• Updated certification information in Section 7.7 table	10
• Corrected ground symbols for "Input (Devices with F suffix)" in Section 9.4.1	24
• Added Section 10.2.3.1 sub-section under Section 10.2.3 section.....	28
• Added 'How to use isolation to improve ESD, EFT, and Surge immunity in industrial systems' application report to Section 13.1 section	31

Changes from Revision A (May 2017) to Revision B (June 2018) Page

• Changed the DIN certification number and certification status throughout the document	1
• Changed the isolation rating of the DBQ package from 2500 V_{RMS} to 3000 V_{RMS}	1
• Moved the HBM and CDM values from the <i>Features</i> section to the <i>ESD Ratings</i> table.....	7
• Added V_{TEST} to the conditions for the maximum transient isolation voltage parameter in the <i>Insulation Specifications</i> table.....	9
• Changed the value for the DBQ package from 3600 VPK to 4242 V_{PK} throughout the document.....	9
• Changed the method b1 V_{ini} condition for apparent charge in the <i>Insulation Specifications</i> table.....	9

Changes from Revision * (November 2016) to Revision A (May 2017) Page

• Updated the <i>Safety-Related Certifications</i> table.....	10
• Changed the minimum CMTI from 40 to 85 in all <i>Electrical Characteristics</i> tables	11

5 Description Continued

The ISO7730-Q1 device has all three channels in the same direction and the ISO7731-Q1 device has two forward and one reverse-direction channel. If the input power or signal is lost, the default output is *high* for devices without suffix F and *low* for devices with suffix F. See the [Device Functional Modes](#) section for further details.

Used in conjunction with isolated power supplies, this family of devices helps prevent noise currents on data buses, such as CAN and LIN, or other circuits from entering the local ground and interfering with or damaging sensitive circuitry. Through innovative chip design and layout techniques, electromagnetic compatibility of the ISO773x-Q1 device has been significantly enhanced to ease system-level ESD, EFT, surge, and emissions compliance. The ISO773x-Q1 family of devices is available in 16-pin wide-SOIC and QSOP packages.

6 Pin Configuration and Functions

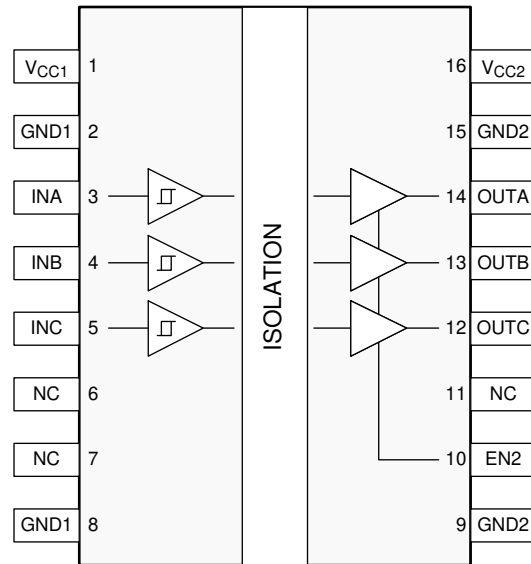

Figure 6-1. ISO7730-Q1 DW and DBQ Packages 16-Pin SOIC-WB and QSOP Top View

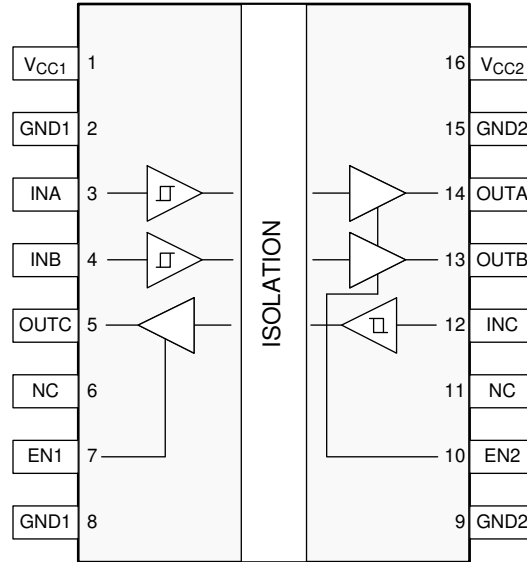

Figure 6-2. ISO7731-Q1 DW and DBQ Packages 16-Pin SOIC-WB and QSOP Top View

Table 6-1. Pin Functions

NAME	PIN		I/O	DESCRIPTION
	NO.			
	ISO7730-Q1	ISO7731-Q1		
EN1	—	7	I	Output enable 1. Output pins on side 1 are enabled when EN1 is high or open and in high-impedance state when EN1 is low.
EN2	10	10	I	Output enable 2. Output pins on side 2 are enabled when EN2 is high or open and in high-impedance state when EN2 is low.
GND1	2, 8	2, 8	—	Ground connection for V_{CC1}
GND2	9, 15	9, 15	—	Ground connection for V_{CC2}
INA	3	3	I	Input, channel A
INB	4	4	I	Input, channel B
INC	5	12	I	Input, channel C
NC	6, 7, 11	6, 11	—	Not connected
OUTA	14	14	O	Output, channel A
OUTB	13	13	O	Output, channel B
OUTC	12	5	O	Output, channel C
V_{CC1}	1	1	—	Power supply, V_{CC1}
V_{CC2}	16	16	—	Power supply, V_{CC2}

7 Specifications

7.1 Absolute Maximum Ratings

See (1)

		MIN	MAX	UNIT
V_{CC1}, V_{CC2}	Supply voltage ⁽²⁾	-0.5	6	V
V	Voltage at INx, OUTx, ENx	-0.5	$V_{CCX} + 0.5$ ⁽³⁾	V
I_O	Output current	-15	15	mA
T_J	Junction temperature		150	°C
T_{stg}	Storage temperature	-65	150	°C

- (1) Stresses beyond those listed under *Absolute Maximum Ratings* may cause permanent damage to the device. These are stress ratings only and functional operation of the device at these or any other conditions beyond those indicated under *Recommended Operating Conditions* is not implied. Exposure to absolute-maximum-rated conditions for extended periods may affect device reliability.
- (2) All voltage values except differential I/O bus voltages are with respect to the local ground terminal (GND1 or GND2) and are peak voltage values.
- (3) Maximum voltage must not exceed 6 V.

7.2 ESD Ratings

		VALUE	UNIT
$V_{(ESD)}$	Electrostatic discharge	Human-body model (HBM), per AEC Q100-002 ⁽¹⁾ HBM ESD Classification Level 3A	±6000
		Charged-device model (CDM), per AEC Q100-011 CDM ESD Classification Level C6	±1500
		Contact discharge per IEC 61000-4-2; Isolation barrier withstand test ^{(2) (3)}	±8000

- (1) AEC Q100-002 indicates that HBM stressing shall be in accordance with the ANSI/ESDA/JEDEC JS-001 specification.
- (2) IEC ESD strike is applied across the barrier with all pins on each side tied together creating a two-terminal device.
- (3) Testing is carried out in air or oil to determine the intrinsic contact discharge capability of the device.

7.3 Recommended Operating Conditions

		MIN	NOM	MAX	UNIT
V_{CC1}, V_{CC2}	Supply voltage	2.25		5.5	V
$V_{CC(UVLO+)}$	UVLO threshold when supply voltage is rising		2	2.25	V
$V_{CC(UVLO-)}$	UVLO threshold when supply voltage is falling	1.7	1.8		V
$V_{HYS(UVLO)}$	Supply voltage UVLO hysteresis	100	200		mV
I_{OH}	High-level output current	V_{CCO} ⁽¹⁾ = 5 V		-4	mA
		V_{CCO} = 3.3 V		-2	
		V_{CCO} = 2.5 V		-1	
I_{OL}	Low-level output current	V_{CCO} = 5 V		4	mA
		V_{CCO} = 3.3 V		2	
		V_{CCO} = 2.5 V		1	
V_{IH}	High-level input voltage	$0.7 \times V_{CCI}$ ⁽¹⁾		V_{CCI}	V
V_{IL}	Low-level input voltage	0		$0.3 \times V_{CCI}$	V
DR ⁽²⁾	Data rate ⁽²⁾	0		100	Mbps
T_A	Ambient temperature	-40	25	125	°C

- (1) V_{CCI} = Input-side V_{CC} ; V_{CCO} = Output-side V_{CC} .
- (2) 100 Mbps is the maximum specified data rate, although higher data rates are possible.

7.4 Thermal Information

THERMAL METRIC ⁽¹⁾		ISO773x-Q1		UNIT
		DW (SOIC)	DBQ (QSOP)	
		16 Pins	16 Pins	
$R_{\theta JA}$	Junction-to-ambient thermal resistance	81.4	109	°C/W
$R_{\theta JC(top)}$	Junction-to-case(top) thermal resistance	44.9	46.8	°C/W
$R_{\theta JB}$	Junction-to-board thermal resistance	45.9	60.6	°C/W
Ψ_{JT}	Junction-to-top characterization parameter	28.1	35.9	°C/W
Ψ_{JB}	Junction-to-board characterization parameter	45.5	60	°C/W
$R_{\theta JC(bottom)}$	Junction-to-case(bottom) thermal resistance	—	—	°C/W

(1) For more information about traditional and new thermal metrics, see the [Semiconductor and IC Package Thermal Metrics application report](#).

7.5 Power Ratings

PARAMETER		TEST CONDITIONS	MIN	TYP	MAX	UNIT
ISO7730-Q1						
P_D	Maximum power dissipation	$V_{CC1} = V_{CC2} = 5.5\text{ V}$, $T_J = 150^\circ\text{C}$, $C_L = 15\text{ pF}$, input a 50-MHz 50% duty cycle square wave			150	mW
P_{D1}	Maximum power dissipation by side-1		25			mW
P_{D2}	Maximum power dissipation by side-2				125	mW
ISO7731-Q1						
P_D	Maximum power dissipation	$V_{CC1} = V_{CC2} = 5.5\text{ V}$, $T_J = 150^\circ\text{C}$, $C_L = 15\text{ pF}$, input a 50-MHz 50% duty cycle square wave			150	mW
P_{D1}	Maximum power dissipation by side-1		50			mW
P_{D2}	Maximum power dissipation by side-2				100	mW

7.6 Insulation Specifications

PARAMETER		TEST CONDITIONS	SPECIFICATION		UNIT
			DW-16	DBQ-16	
CLR	External clearance ⁽¹⁾	Shortest terminal-to-terminal distance through air	>8	>3.7	mm
CPG	External creepage ⁽¹⁾	Shortest terminal-to-terminal distance across the package surface	>8	>3.7	mm
DTI	Distance through the insulation	Minimum internal gap (internal clearance)	>21	>21	µm
CTI	Comparative tracking index	DIN EN 60112 (VDE 0303-11); IEC 60112; UL 746A	>600	>600	V
	Material group	According to IEC 60664-1	I	I	
	Overvoltage category per IEC 60664-1	Rated mains voltage ≤ 150 V _{RMS}	I–IV	I–IV	
		Rated mains voltage ≤ 300 V _{RMS}	I–IV	I–III	
		Rated mains voltage ≤ 600 V _{RMS}	I–IV	n/a	
		Rated mains voltage ≤ 1000 V _{RMS}	I–III	n/a	
DIN VDE V 0884-11:2017-01⁽²⁾					
V _{IORM}	Maximum repetitive peak isolation voltage	AC voltage (bipolar)	2121	566	V _{PK}
V _{IOWM}	Maximum working isolation voltage	AC voltage; Time dependent dielectric breakdown (TDDB) Test; See Figure 10-8	1500	400	V _{RMS}
		DC Voltage	2121	566	V _{DC}
V _{IOTM}	Maximum transient isolation voltage	V _{TEST} = V _{IOTM} , t = 60 s (qualification); V _{TEST} = 1.2 × V _{IOTM} , t = 1 s (100% production)	8000	4242	V _{PK}
V _{IOSM}	Maximum surge isolation voltage ⁽³⁾	Test method per IEC 62368-1; 1.2/50 µs waveform, V _{TEST} = 1.6 × V _{IOSM} (qualification)	8000	4000	V _{PK}
q _{pd}	Apparent charge ⁽⁴⁾	Method a, After Input/Output safety test subgroup 2/3, V _{ini} = V _{IOTM} , t _{ini} = 60 s; V _{pd(m)} = 1.2 × V _{IORM} , t _m = 10 s	≤5	≤5	pC
		Method a, After environmental tests subgroup 1, V _{ini} = V _{IOTM} , t _{ini} = 60 s; V _{pd(m)} = 1.6 × V _{IORM} , t _m = 10 s	≤5	≤5	
		Method b1; At routine test (100% production) and preconditioning (type test) V _{ini} = 1.2 × V _{IOTM} , t _{ini} = 1 s; V _{pd(m)} = 1.875 × V _{IORM} , t _m = 1 s	≤5	≤5	
C _{IO}	Barrier capacitance, input to output ⁽⁵⁾	V _{IO} = 0.4 x sin (2πft), f = 1 MHz	~0.7	~0.7	pF
R _{IO}	Isolation resistance ⁽⁵⁾	V _{IO} = 500 V, T _A = 25°C	>10 ¹²	>10 ¹²	Ω
		V _{IO} = 500 V, 100°C ≤ T _A ≤ 125°C	>10 ¹¹	>10 ¹¹	
		V _{IO} = 500 V at T _S = 150°C	>10 ⁹	>10 ⁹	
	Pollution degree		2	2	
	Climatic category		55/125/21	55/125/21	
UL 1577					
V _{ISO}	Withstanding isolation voltage	V _{TEST} = V _{ISO} , t = 60 s (qualification), V _{TEST} = 1.2 × V _{ISO} , t = 1 s (100% production)	5000	3000	V _{RMS}

- (1) Creepage and clearance requirements should be applied according to the specific equipment isolation standards of an application. Care should be taken to maintain the creepage and clearance distance of a board design to ensure that the mounting pads of the isolator on the printed-circuit board do not reduce this distance. Creepage and clearance on a printed-circuit board become equal in certain cases. Techniques such as inserting grooves and/or ribs on a printed circuit board are used to help increase these specifications.
- (2) This coupler is suitable for *safe electrical insulation* only within the safety ratings. Compliance with the safety ratings shall be ensured by means of suitable protective circuits.
- (3) Testing is carried out in air or oil to determine the intrinsic surge immunity of the isolation barrier.
- (4) Apparent charge is electrical discharge caused by a partial discharge (pd).
- (5) All pins on each side of the barrier tied together creating a two-terminal device.

7.7 Safety-Related Certifications

VDE	CSA	UL	CQC	TUV
Certified according to DIN VDE V 0884-11:2017-01	Certified according to IEC 60950-1, IEC 62368-1 and IEC 60601-1	Certified according to UL 1577 Component Recognition Program	Certified according to GB 4943.1-2011	Certified according to EN 61010-1:2010/A1:2019, EN 60950-1:2006/A2:2013 and EN 62368-1:2014
Maximum transient isolation voltage, 8000 V _{PK} (DW-16) and 4242 V _{PK} (DBQ-16); Maximum repetitive peak isolation voltage, 2121 V _{PK} (DW-16, Reinforced) and 566 V _{PK} (DBQ-16); Maximum surge isolation voltage, 8000 V _{PK} (DW-16) and 4000 V _{PK} (DBQ-16)	Reinforced insulation per CSA 60950-1-07+A1+A2, IEC 60950-1 2nd Ed.+A1+A2, CSA 62368-1-14 and IEC 62368-1:2014, 800 V _{RMS} (DW-16) max working voltage (pollution degree 2, material group I); 2 MOPP (Means of Patient Protection) per CSA 60601-1:14 and IEC 60601-1 Ed. 3.1, 250 V _{RMS} (DW-16) max working voltage	DW-16: Single protection, 5000 V _{RMS} ; DBQ-16: Single protection, 3000 V _{RMS}	DW-16: Reinforced Insulation, Altitude ≤ 5000 m, Tropical Climate, 700 V _{RMS} maximum working voltage; DBQ-16: Basic Insulation, Altitude ≤ 5000 m, Tropical Climate, 400 V _{RMS} maximum working voltage	5000 V _{RMS} (DW-16) and 3000 V _{RMS} (DBQ-16) Reinforced insulation per EN 61010-1:2010/A1:2019 up to working voltage of 600 V _{RMS} (DW-16) and 300 V _{RMS} (DBQ-16) 5000 V _{RMS} (DW-16) and 3000 V _{RMS} (DBQ-16) Reinforced insulation per EN 60950-1:2006/A2:2013 and EN 62368-1:2014 up to working voltage of 800 V _{RMS} (DW-16) and 370 V _{RMS} (DBQ-16)
Certificate number: 40040142	Master contract number: 220991	File number: E181974	Certificate numbers: CQC15001121716 (DW-16) CQC18001199097 (DBQ-16)	Client ID number: 77311

7.8 Safety Limiting Values

Safety limiting⁽¹⁾ intends to minimize potential damage to the isolation barrier upon failure of input or output circuitry. A failure of the I/O can allow low resistance to ground or the supply and, without current limiting, dissipate sufficient power to overheat the die and damage the isolation barrier potentially leading to secondary system failures.

PARAMETER		TEST CONDITIONS	MIN	TYP	MAX	UNIT
DW-16 PACKAGE						
I _S	Safety input, output, or supply current	R _{θJA} = 81.4 °C/W, V _I = 5.5 V, T _J = 150°C, T _A = 25°C, see Figure 7-1			279	mA
		R _{θJA} = 81.4 °C/W, V _I = 3.6 V, T _J = 150°C, T _A = 25°C, see Figure 7-1			427	
		R _{θJA} = 81.4 °C/W, V _I = 2.75 V, T _J = 150°C, T _A = 25°C, see Figure 7-1			558	
P _S	Safety input, output, or total power	R _{θJA} = 81.4 °C/W, T _J = 150°C, T _A = 25°C, see Figure 7-3			1536	mW
T _S	Maximum safety temperature				150	°C
DBQ-16 PACKAGE						
I _S	Safety input, output, or supply current	R _{θJA} = 109.0°C/W, V _I = 5.5 V, T _J = 150°C, T _A = 25°C, see Figure 7-2			209	mA
		R _{θJA} = 109.0 °C/W, V _I = 3.6 V, T _J = 150°C, T _A = 25°C, see Figure 7-2			319	
		R _{θJA} = 109.0°C/W, V _I = 2.75 V, T _J = 150°C, T _A = 25°C, see Figure 7-2			417	
P _S	Safety input, output, or total power	R _{θJA} = 109.0°C/W, T _J = 150°C, T _A = 25°C, see Figure 7-4			1147	mW
T _S	Maximum safety temperature				150	°C

- (1) The maximum safety temperature is the maximum junction temperature specified for the device. The power dissipation and junction-to-air thermal impedance of the device installed in the application hardware determines the junction temperature. The assumed junction-to-air thermal resistance in the [Section 7.4](#) is that of a device installed on a High-K test board for leaded surface mount packages. The power is the recommended maximum input voltage times the current. The junction temperature is then the ambient temperature plus the power times the junction-to-air thermal resistance.

7.9 Electrical Characteristics—5-V Supply

$V_{CC1} = V_{CC2} = 5\text{ V} \pm 10\%$ (over recommended operating conditions unless otherwise noted)

PARAMETER	TEST CONDITIONS	MIN	TYP	MAX	UNIT
V_{OH}	High-level output voltage $I_{OH} = -4\text{ mA}$; see Figure 8-1	$V_{CCO}^{(1)} - 0.4$	4.8		V
V_{OL}	Low-level output voltage $I_{OL} = 4\text{ mA}$; see Figure 8-1		0.2	0.4	V
$V_{IT+(IN)}$	Rising input voltage threshold		$0.6 \times V_{CCI}$	$0.7 \times V_{CCI}$	V
$V_{IT-(IN)}$	Falling input voltage threshold	$0.3 \times V_{CCI}$	$0.4 \times V_{CCI}$		V
$V_{I(HYS)}$	Input threshold voltage hysteresis	$0.1 \times V_{CCI}$	$0.2 \times V_{CCI}$		V
I_{IH}	High-level input current $V_{IH} = V_{CCI}^{(1)}$ at INx or ENx			10	μA
I_{IL}	Low-level input current $V_{IL} = 0\text{ V}$ at INx or ENx	-10			μA
CMTI	Common-mode transient immunity $V_I = V_{CCI}$ or 0 V , $V_{CM} = 1200\text{ V}$; see Figure 8-4	85	100		$\text{kV}/\mu\text{s}$
C_i	Input Capacitance ⁽²⁾ $V_I = V_{CC}/2 + 0.4 \times \sin(2\pi f t)$, $f = 1\text{ MHz}$, $V_{CC} = 5\text{ V}$		2		pF

(1) V_{CCI} = Input-side V_{CC} ; V_{CCO} = Output-side V_{CC} .

(2) Measured from input pin to ground.

7.10 Supply Current Characteristics—5-V Supply

$V_{CC1} = V_{CC2} = 5\text{ V} \pm 10\%$ (over recommended operating conditions unless otherwise noted)

PARAMETER	TEST CONDITIONS	SUPPLY CURRENT	MIN	TYP	MAX	UNIT	
ISO7730-Q1							
Supply current - disable	$EN2 = 0\text{ V}$; $V_I = V_{CC1}$ (ISO7730-Q1); $V_I = 0\text{ V}$ (ISO7730-Q1 with F suffix)	I_{CC1}		1	1.4	mA	
		I_{CC2}		0.3	0.4	mA	
	$EN2 = 0\text{ V}$; $V_I = 0\text{ V}$ (ISO7730-Q1); $V_I = V_{CC1}$ (ISO7730-Q1 with F suffix)	I_{CC1}		4.3	6	mA	
		I_{CC2}		0.3	0.4	mA	
Supply current - DC signal	$EN2 = V_{CC2}$; $V_I = V_{CC1}$ (ISO7730-Q1); $V_I = 0\text{ V}$ (ISO7730-Q1 with F suffix)	I_{CC1}		1	1.4	mA	
		I_{CC2}		1.6	2.5	mA	
	$EN2 = V_{CC2}$; $V_I = 0\text{ V}$ (ISO7730-Q1); $V_I = V_{CC1}$ (ISO7730-Q1 with F suffix)	I_{CC1}		4.3	6	mA	
		I_{CC2}		1.8	2.7	mA	
Supply current - AC signal	$EN2 = V_{CC1}$; All channels switching with square wave clock input; $C_L = 15\text{ pF}$	1 Mbps	I_{CC1}		2.6	3.7	mA
			I_{CC2}		1.9	2.8	mA
		10 Mbps	I_{CC1}		2.7	3.8	mA
			I_{CC2}		3.3	4.5	mA
		100 Mbps	I_{CC1}		3.6	4.6	mA
			I_{CC2}		17.5	21	mA
ISO7731-Q1							
Supply current - disable	$EN1 = EN2 = 0\text{ V}$; $V_I = V_{CCI}^{(1)}$ (ISO7731-Q1); $V_I = 0\text{ V}$ (ISO7731-Q1 with F suffix)	I_{CC1}		0.8	1.2	mA	
		I_{CC2}		0.7	1	mA	
	$EN1 = EN2 = 0\text{ V}$; $V_I = 0\text{ V}$ (ISO7731-Q1); $V_I = V_{CCI}$ (ISO7731-Q1 with F suffix)	I_{CC1}		3	4.3	mA	
		I_{CC2}		1.8	2.6	mA	
Supply current - DC signal	$EN1 = EN2 = V_{CCI}$; $V_I = V_{CCI}$ (ISO7731-Q1); $V_I = 0\text{ V}$ (ISO7731-Q1 with F suffix)	I_{CC1}		1.3	1.7	mA	
		I_{CC2}		1.6	2.2	mA	
	$EN1 = EN2 = V_{CCI}$; $V_I = 0\text{ V}$ (ISO7731-Q1); $V_I = V_{CCI}$ (ISO7731-Q1 with F suffix)	I_{CC1}		3.5	5	mA	
		I_{CC2}		2.8	4.1	mA	

ISO7730-Q1, ISO7731-Q1

SLLSEU3D – NOVEMBER 2016 – REVISED OCTOBER 2020

 $V_{CC1} = V_{CC2} = 5\text{ V} \pm 10\%$ (over recommended operating conditions unless otherwise noted)

PARAMETER	TEST CONDITIONS	SUPPLY CURRENT	MIN	TYP	MAX	UNIT
Supply current - AC signal	EN1 = EN2 = V_{CCI} ; All channels switching with square wave clock input; $C_L = 15\text{ pF}$	1 Mbps	I_{CC1}	2.7	3.4	mA
			I_{CC2}	2.3	3.3	mA
		10 Mbps	I_{CC1}	3	4	mA
			I_{CC2}	3.3	4.4	mA
		100 Mbps	I_{CC1}	8.5	11	mA
			I_{CC2}	13.1	16	mA

 (1) $V_{CCI} = \text{Input-side } V_{CC}$

7.11 Electrical Characteristics—3.3-V Supply

$V_{CC1} = V_{CC2} = 3.3\text{ V} \pm 10\%$ (over recommended operating conditions unless otherwise noted)

PARAMETER	TEST CONDITIONS	MIN	TYP	MAX	UNIT
V_{OH}	High-level output voltage $I_{OH} = -2\text{ mA}$; see Figure 8-1	$V_{CCO}^{(1)} - 0.3$	3.2		V
V_{OL}	Low-level output voltage $I_{OL} = 2\text{ mA}$; see Figure 8-1		0.1	0.3	V
$V_{IT+(IN)}$	Rising input voltage threshold		$0.6 \times V_{CCI}$	$0.7 \times V_{CCI}$	V
$V_{IT-(IN)}$	Falling input voltage threshold		$0.3 \times V_{CCI}$	$0.4 \times V_{CCI}$	V
$V_{I(HYS)}$	Input threshold voltage hysteresis		$0.1 \times V_{CCI}$	$0.2 \times V_{CCI}$	V
I_{IH}	High-level input current $V_{IH} = V_{CCI}^{(1)}$ at INx or ENx			10	μA
I_{IL}	Low-level input current $V_{IL} = 0\text{ V}$ at INx or ENx	-10			μA
CMTI	Common-mode transient immunity $V_I = V_{CCI}$ or 0 V , $V_{CM} = 1200\text{ V}$; see Figure 8-4	85	100		$\text{kV}/\mu\text{s}$

(1) V_{CCI} = Input-side V_{CC} ; V_{CCO} = Output-side V_{CC} .

7.12 Supply Current Characteristics—3.3-V Supply

$V_{CC1} = V_{CC2} = 3.3\text{ V} \pm 10\%$ (over recommended operating conditions unless otherwise noted)

PARAMETER	TEST CONDITIONS	SUPPLY CURRENT	MIN	TYP	MAX	UNIT	
ISO7730-Q1							
Supply current - disable	$EN2 = 0\text{ V}$; $V_I = V_{CC1}$ (ISO7730-Q1); $V_I = 0\text{ V}$ (ISO7730-Q1 with F suffix)	I_{CC1}		1	1.4	mA	
		I_{CC2}		0.3	0.4	mA	
	$EN2 = 0\text{ V}$; $V_I = 0\text{ V}$ (ISO7730-Q1); $V_I = V_{CC1}$ (ISO7730-Q1 with F suffix)	I_{CC1}		4.3	6	mA	
		I_{CC2}		0.3	0.4	mA	
Supply current - DC signal	$EN2 = V_{CC2}$; $V_I = V_{CC1}$ (ISO7730-Q1); $V_I = 0\text{ V}$ (ISO7730-Q1 with F suffix)	I_{CC1}		1	1.4	mA	
		I_{CC2}		1.6	2.5	mA	
	$EN2 = V_{CC2}$; $V_I = 0\text{ V}$ (ISO7730-Q1); $V_I = V_{CC1}$ (ISO7730-Q1 with F suffix)	I_{CC1}		4.3	6	mA	
		I_{CC2}		1.8	2.7	mA	
Supply current - AC signal	$EN2 = V_{CCI}$; All channels switching with square wave clock input; $C_L = 15\text{ pF}$	1 Mbps	I_{CC1}		2.6	3.7	mA
			I_{CC2}		1.8	2.8	mA
		10 Mbps	I_{CC1}		2.7	3.8	mA
			I_{CC2}		2.8	3.9	mA
		100 Mbps	I_{CC1}		3.3	4.3	mA
			I_{CC2}		13	17	mA
ISO7731-Q1							
Supply current - disable	$EN1 = EN2 = 0\text{ V}$; $V_I = V_{CCI}^{(1)}$ (ISO7731-Q1); $V_I = 0\text{ V}$ (ISO7731-Q1 with F suffix)	I_{CC1}		0.8	1.2	mA	
		I_{CC2}		0.7	1	mA	
	$EN1 = EN2 = 0\text{ V}$; $V_I = 0\text{ V}$ (ISO7731-Q1); $V_I = V_{CCI}$ (ISO7731-Q1 with F suffix)	I_{CC1}		3	4.3	mA	
		I_{CC2}		1.8	2.6	mA	
Supply current - DC signal	$EN1 = EN2 = V_{CCI}$; $V_I = V_{CCI}$ (ISO7731-Q1); $V_I = 0\text{ V}$ (ISO7731-Q1 with F suffix)	I_{CC1}		1.3	1.7	mA	
		I_{CC2}		1.6	2.2	mA	
	$EN1 = EN2 = V_{CCI}$; $V_I = 0\text{ V}$ (ISO7731-Q1); $V_I = V_{CCI}$ (ISO7731-Q1 with F suffix)	I_{CC1}		3.5	5	mA	
		I_{CC2}		2.8	4.1	mA	
Supply current - AC signal	$EN1 = EN2 = V_{CCI}$; All channels switching with square wave clock input; $C_L = 15\text{ pF}$	1 Mbps	I_{CC1}		2.4	3.4	mA
			I_{CC2}		2.2	3.3	mA
		10 Mbps	I_{CC1}		2.8	3.8	mA
			I_{CC2}		2.9	4	mA
		100 Mbps	I_{CC1}		6.7	8.5	mA
			I_{CC2}		10	12.5	mA

(1) V_{CCI} = Input-side V_{CC}

7.13 Electrical Characteristics—2.5-V Supply

 $V_{CC1} = V_{CC2} = 2.5\text{ V} \pm 10\%$ (over recommended operating conditions unless otherwise noted)

PARAMETER	TEST CONDITIONS	MIN	TYP	MAX	UNIT
V_{OH}	High-level output voltage $I_{OH} = -1\text{ mA}$; see Figure 8-1	$V_{CCO}^{(1)} - 0.2$	2.45		V
V_{OL}	Low-level output voltage $I_{OL} = 1\text{ mA}$; see Figure 8-1		0.05	0.2	V
$V_{IT+(IN)}$	Rising input voltage threshold		$0.6 \times V_{CCI}$	$0.7 \times V_{CCI}$	V
$V_{IT-(IN)}$	Falling input voltage threshold	$0.3 \times V_{CCI}$	$0.4 \times V_{CCI}$		V
$V_{I(HYS)}$	Input threshold voltage hysteresis	$0.1 \times V_{CCI}$	$0.2 \times V_{CCI}$		V
I_{IH}	High-level input current $V_{IH} = V_{CCI}^{(1)}$ at INx or ENx			10	μA
I_{IL}	Low-level input current $V_{IL} = 0\text{ V}$ at INx or ENx	-10			μA
CMTI	Common-mode transient immunity $V_I = V_{CCI}$ or 0 V , $V_{CM} = 1200\text{ V}$; see Figure 8-4	85	100		$\text{kV}/\mu\text{s}$

 (1) V_{CCI} = Input-side V_{CC} ; V_{CCO} = Output-side V_{CC} .

7.14 Supply Current Characteristics—2.5-V Supply

 $V_{CC1} = V_{CC2} = 2.5\text{ V} \pm 10\%$ (over recommended operating conditions unless otherwise noted)

PARAMETER	TEST CONDITIONS	SUPPLY CURRENT	MIN	TYP	MAX	UNIT	
ISO7730-Q1							
Supply current - disable	EN2 = 0 V; $V_I = V_{CC1}$ (ISO7730-Q1); $V_I = 0\text{ V}$ (ISO7730-Q1 with F suffix)	I_{CC1}		1	1.4	mA	
		I_{CC2}		0.3	0.4	mA	
	EN2 = 0 V; $V_I = 0\text{ V}$ (ISO7730-Q1); $V_I = V_{CC1}$ (ISO7730-Q1 with F suffix)	I_{CC1}		4.3	6	mA	
		I_{CC2}		0.3	0.4	mA	
Supply current - DC signal	EN2 = V_{CC2} ; $V_I = V_{CC1}$ (ISO7730-Q1); $V_I = 0\text{ V}$ (ISO7730-Q1 with F suffix)	I_{CC1}		1	1.4	mA	
		I_{CC2}		1.6	2.5	mA	
	EN2 = V_{CC2} ; $V_I = 0\text{ V}$ (ISO7730-Q1); $V_I = V_{CC1}$ (ISO7730-Q1 with F suffix)	I_{CC1}		4.3	6	mA	
		I_{CC2}		1.8	2.7	mA	
Supply current - AC signal	EN2 = V_{CC2} ; All channels switching with square wave clock input; $C_L = 15\text{ pF}$	1 Mbps	I_{CC1}		2.6	3.7	mA
			I_{CC2}		1.8	2.7	mA
		10 Mbps	I_{CC1}		2.6	3.8	mA
			I_{CC2}		2.5	3.6	mA
		100 Mbps	I_{CC1}		3.1	4.2	mA
			I_{CC2}		10.2	14	mA
ISO7731-Q1							
Supply current - disable	EN1 = EN2 = 0 V; $V_I = V_{CCI}^{(1)}$ (ISO7731-Q1); $V_I = 0\text{ V}$ (ISO7731-Q1 with F suffix)	I_{CC1}		0.8	1.2	mA	
		I_{CC2}		0.7	1	mA	
	EN1 = EN2 = 0 V; $V_I = 0\text{ V}$ (ISO7731-Q1); $V_I = V_{CCI}$ (ISO7731-Q1 with F suffix)	I_{CC1}		3	4.3	mA	
		I_{CC2}		1.8	2.6	mA	
Supply current - DC signal	EN1 = EN2 = V_{CCI} ; $V_I = V_{CCI}$ (ISO7731-Q1); $V_I = 0\text{ V}$ (ISO7731-Q1 with F suffix)	I_{CC1}		1.3	1.7	mA	
		I_{CC2}		1.6	2.2	mA	
	EN1 = EN2 = V_{CCI} ; $V_I = 0\text{ V}$ (ISO7731-Q1); $V_I = V_{CCI}$ (ISO7731-Q1 with F suffix)	I_{CC1}		3.5	5	mA	
		I_{CC2}		2.8	4.1	mA	
Supply current - AC signal	EN1 = EN2 = V_{CCI} ; All channels switching with square wave clock input; $C_L = 15\text{ pF}$	1 Mbps	I_{CC1}		2.4	3.4	mA
			I_{CC2}		2.2	3.2	mA
		10 Mbps	I_{CC1}		2.7	3.7	mA
			I_{CC2}		2.7	3.8	mA
		100 Mbps	I_{CC1}		5.6	7	mA
			I_{CC2}		8	10	mA

 (1) V_{CCI} = Input-side V_{CC}

7.15 Switching Characteristics—5-V Supply

$V_{CC1} = V_{CC2} = 5\text{ V} \pm 10\%$ (over recommended operating conditions unless otherwise noted)

PARAMETER		TEST CONDITIONS	MIN	TYP	MAX	UNIT	
t_{PLH}, t_{PHL}	Propagation delay time	See Figure 8-1	6	11	16	ns	
PWD	Pulse width distortion ⁽¹⁾ $ t_{PHL} - t_{PLH} $			0.6	4.9	ns	
$t_{sk(o)}$	Channel-to-channel output skew time ⁽²⁾	Same-direction channels			4	ns	
$t_{sk(pp)}$	Part-to-part skew time ⁽³⁾				4.5	ns	
t_r	Output signal rise time	See Figure 8-1		1.3	3.9	ns	
t_f	Output signal fall time			1.4	3.9	ns	
t_{PHZ}	Disable propagation delay, high-to-high impedance output	See Figure 8-2		8	20	ns	
t_{PLZ}	Disable propagation delay, low-to-high impedance output			8	20	ns	
t_{PZH}	Enable propagation delay, high impedance-to-high output for ISO773x-Q1				7	20	ns
	Enable propagation delay, high impedance-to-high output for ISO773x-Q1 with F suffix				3	8.5	μs
t_{PZL}	Enable propagation delay, high impedance-to-low output for ISO773x-Q1				3	8.5	μs
	Enable propagation delay, high impedance-to-low output for ISO773x-Q1 with F suffix				7	20	ns
t_{DO}	Default output delay time from input power loss	Measured from the time V_{CC} goes below 1.7 V. See Figure 8-3		0.1	0.3	μs	
t_{ie}	Time interval error	$2^{16} - 1$ PRBS data at 100 Mbps		0.6		ns	

- (1) Also known as pulse skew.
- (2) $t_{sk(o)}$ is the skew between outputs of a single device with all driving inputs connected together and the outputs switching in the same direction while driving identical loads.
- (3) $t_{sk(pp)}$ is the magnitude of the difference in propagation delay times between any terminals of different devices switching in the same direction while operating at identical supply voltages, temperature, input signals and loads.

7.16 Switching Characteristics—3.3-V Supply

 $V_{CC1} = V_{CC2} = 3.3\text{ V} \pm 10\%$ (over recommended operating conditions unless otherwise noted)

PARAMETER		TEST CONDITIONS	MIN	TYP	MAX	UNIT
t_{PLH} , t_{PHL}	Propagation delay time	See Figure 8-1	6	11	16	ns
PWD	Pulse width distortion ⁽¹⁾ $ t_{PHL} - t_{PLH} $		0.1	5	ns	
$t_{sk(o)}$	Channel-to-channel output skew time ⁽²⁾	Same-direction channels			4.1	ns
$t_{sk(pp)}$	Part-to-part skew time ⁽³⁾				4.5	ns
t_r	Output signal rise time	See Figure 8-1		1.3	3	ns
t_f	Output signal fall time		1.3	3	ns	
t_{PHZ}	Disable propagation delay, high-to-high impedance output	See Figure 8-2		17	30	ns
t_{PLZ}	Disable propagation delay, low-to-high impedance output		17	30	ns	
t_{PZH}	Enable propagation delay, high impedance-to-high output for ISO773x-Q1		17	30	ns	
	Enable propagation delay, high impedance-to-high output for ISO773x-Q1 with F suffix		3.2	8.5	μs	
t_{PZL}	Enable propagation delay, high impedance-to-low output for ISO773x-Q1		3.2	8.5	μs	
	Enable propagation delay, high impedance-to-low output for ISO773x-Q1 with F suffix		17	30	ns	
t_{DO}	Default output delay time from input power loss	Measured from the time V_{CC} goes below 1.7 V. See Figure 8-3	0.1	0.3	μs	
t_{ie}	Time interval error	$2^{16} - 1$ PRBS data at 100 Mbps	0.6		ns	

(1) Also known as Pulse Skew.

(2) $t_{sk(o)}$ is the skew between outputs of a single device with all driving inputs connected together and the outputs switching in the same direction while driving identical loads.

(3) $t_{sk(pp)}$ is the magnitude of the difference in propagation delay times between any terminals of different devices switching in the same direction while operating at identical supply voltages, temperature, input signals and loads.

7.17 Switching Characteristics—2.5-V Supply

 $V_{CC1} = V_{CC2} = 2.5\text{ V} \pm 10\%$ (over recommended operating conditions unless otherwise noted)

PARAMETER		TEST CONDITIONS	MIN	TYP	MAX	UNIT
t_{PLH} , t_{PHL}	Propagation delay time	See Figure 8-1	7.5	12	18.5	ns
PWD	Pulse width distortion ⁽¹⁾ $ t_{PHL} - t_{PLH} $		0.2	5.1	ns	
$t_{sk(o)}$	Channel-to-channel output skew time ⁽²⁾	Same-direction Channels			4.1	ns
$t_{sk(pp)}$	Part-to-part skew time ⁽³⁾				4.6	ns
t_r	Output signal rise time	See Figure 8-1		1	3.5	ns
t_f	Output signal fall time		1	3.5	ns	
t_{PHZ}	Disable propagation delay, high-to-high impedance output	See Figure 8-2		22	40	ns
t_{PLZ}	Disable propagation delay, low-to-high impedance output		22	40	ns	
t_{PZH}	Enable propagation delay, high impedance-to-high output for ISO773x-Q1		18	40	ns	
	Enable propagation delay, high impedance-to-high output for ISO773x-Q1 with F suffix		3.3	8.5	μs	
t_{PZL}	Enable propagation delay, high impedance-to-low output for ISO773x-Q1		3.3	8.5	μs	
	Enable propagation delay, high impedance-to-low output for ISO773x-Q1 with F suffix		18	40	ns	
t_{DO}	Default output delay time from input power loss	Measured from the time V_{CC} goes below 1.7 V. See Figure 8-3	0.1	0.3	μs	
t_{ie}	Time interval error	$2^{16} - 1$ PRBS data at 100 Mbps	0.6		ns	

(1) Also known as pulse skew.

(2) $t_{sk(o)}$ is the skew between outputs of a single device with all driving inputs connected together and the outputs switching in the same direction while driving identical loads.

(3) $t_{sk(pp)}$ is the magnitude of the difference in propagation delay times between any terminals of different devices switching in the same direction while operating at identical supply voltages, temperature, input signals and loads.

7.18 Insulation Characteristics Curves

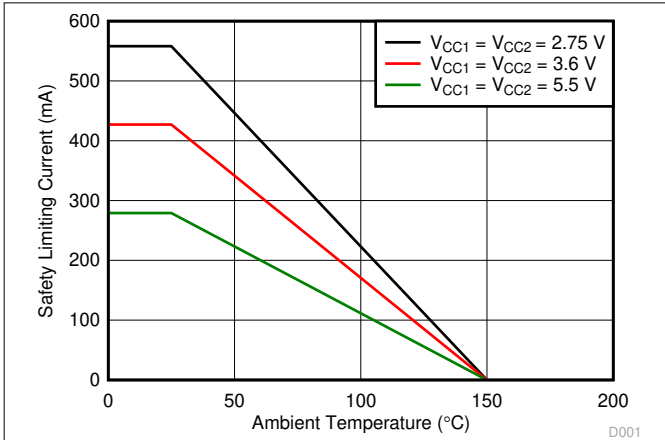

Figure 7-1. Thermal Derating Curve for Safety Limiting Current per VDE for DW-16 Package

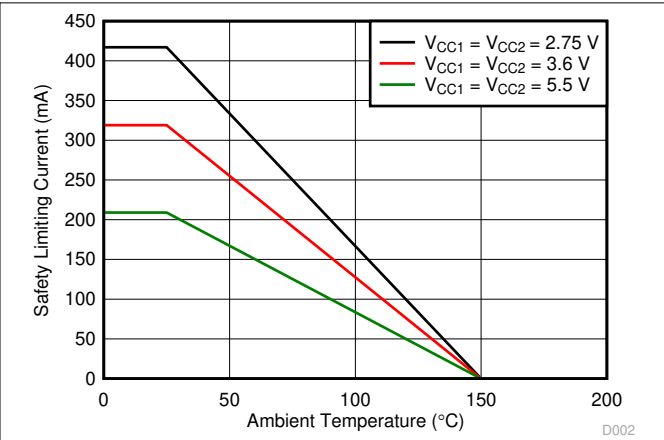

Figure 7-2. Thermal Derating Curve for Safety Limiting Current per VDE for DBQ-16 Package

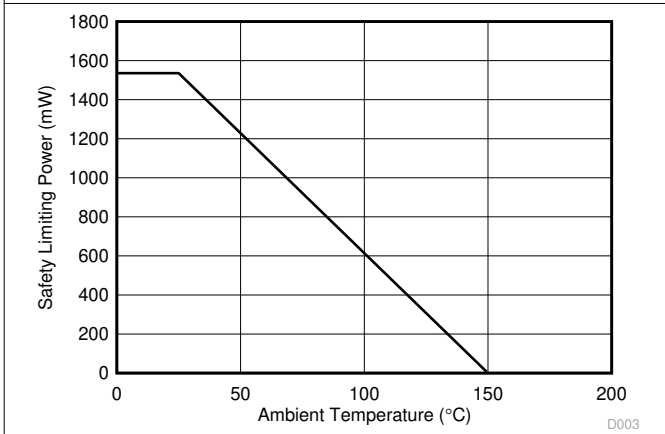

Figure 7-3. Thermal Derating Curve for Safety Limiting Power per VDE for DW-16 Package

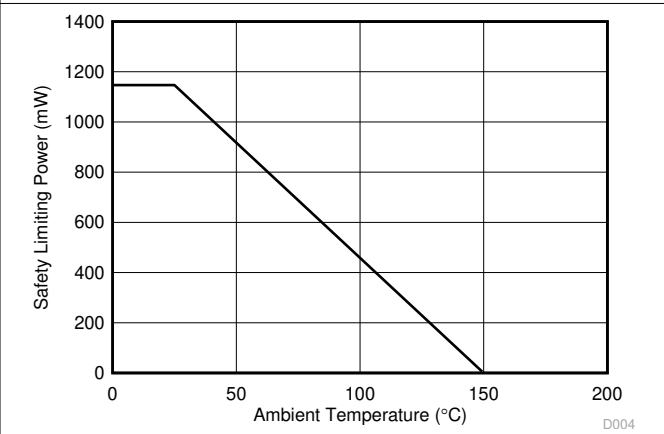

Figure 7-4. Thermal Derating Curve for Safety Limiting Power per VDE for DBQ-16 Package

7.19 Typical Characteristics

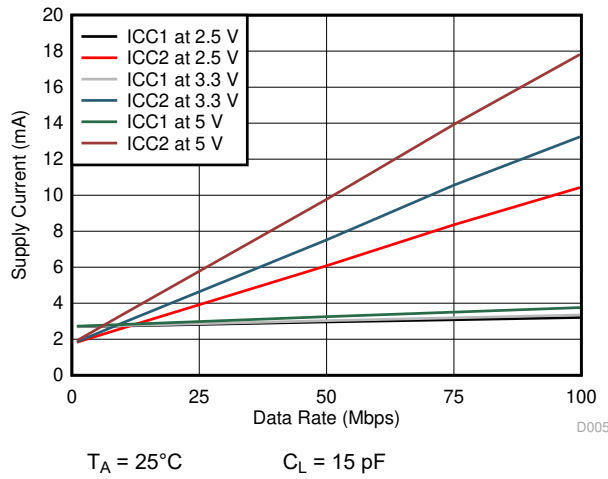

Figure 7-5. ISO7730-Q1 Supply Current vs Data Rate (With 15-pF Load)

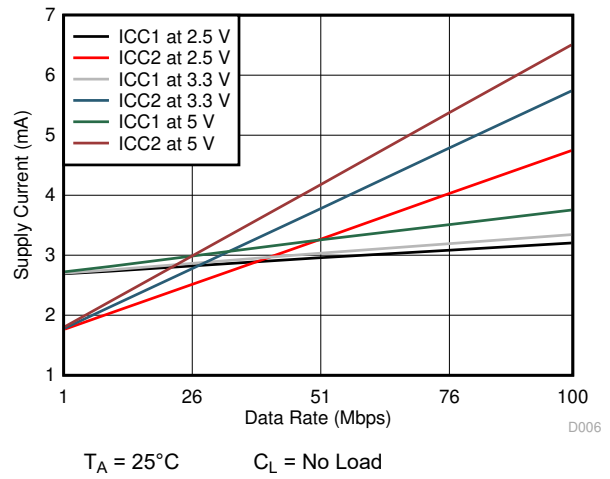

Figure 7-6. ISO7730-Q1 Supply Current vs Data Rate (With No Load)

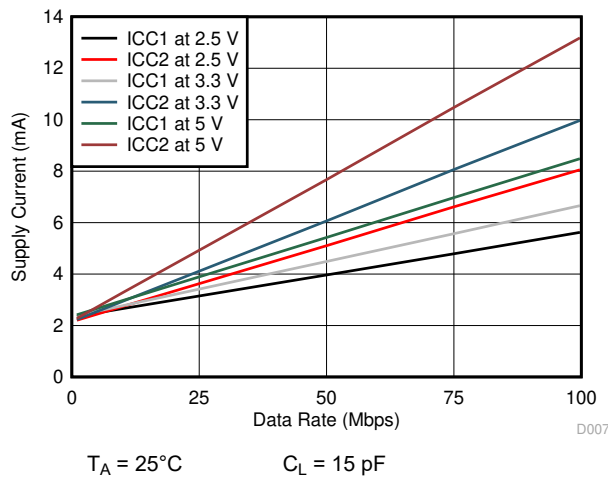

Figure 7-7. ISO7731-Q1 Supply Current vs Data Rate (With 15-pF Load)

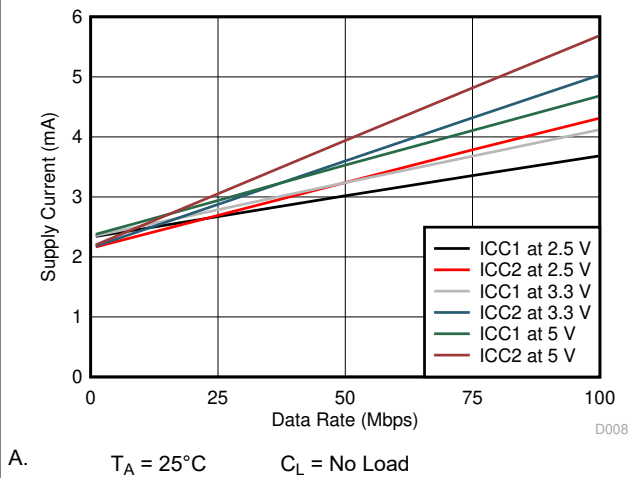

Figure 7-8. ISO7731-Q1 Supply Current vs Data Rate (With No Load)

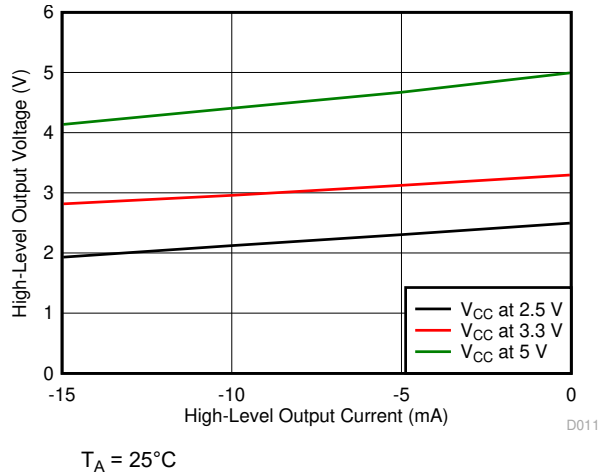

Figure 7-9. High-Level Output Voltage vs High-level Output Current

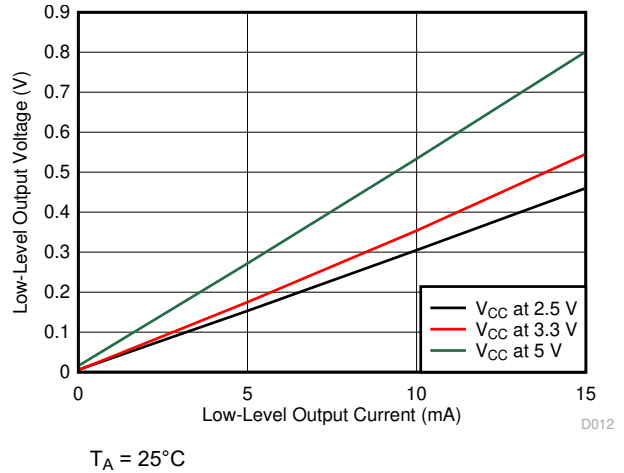

Figure 7-10. Low-Level Output Voltage vs Low-Level Output Current

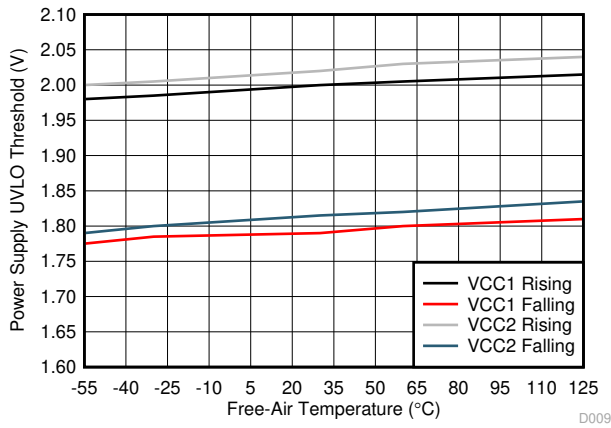

Figure 7-11. Power Supply Undervoltage Threshold vs Free-Air Temperature

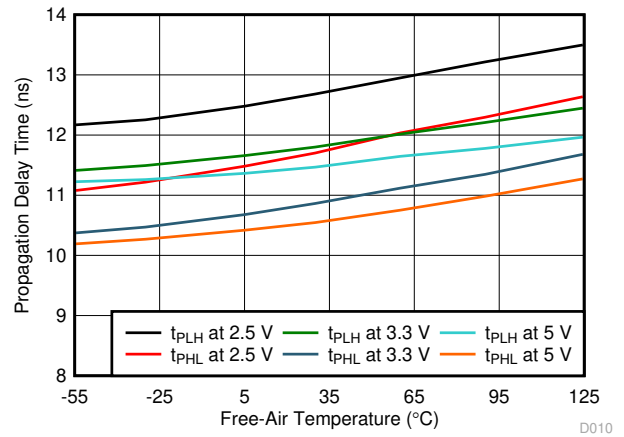
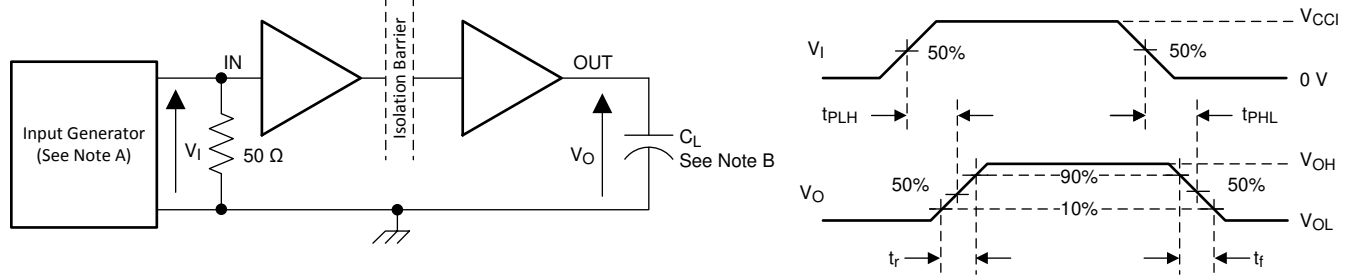

Figure 7-12. Propagation Delay Time vs Free-Air Temperature

8 Parameter Measurement Information



- A. The input pulse is supplied by a generator having the following characteristics: PRR \leq 50 kHz, 50% duty cycle, $t_r \leq$ 3 ns, $t_f \leq$ 3 ns, $Z_O = 50 \Omega$. At the input, 50 Ω resistor is required to terminate Input Generator signal. It is not needed in actual application.
- B. $C_L = 15$ pF and includes instrumentation and fixture capacitance within $\pm 20\%$.

Figure 8-1. Switching Characteristics Test Circuit and Voltage Waveforms

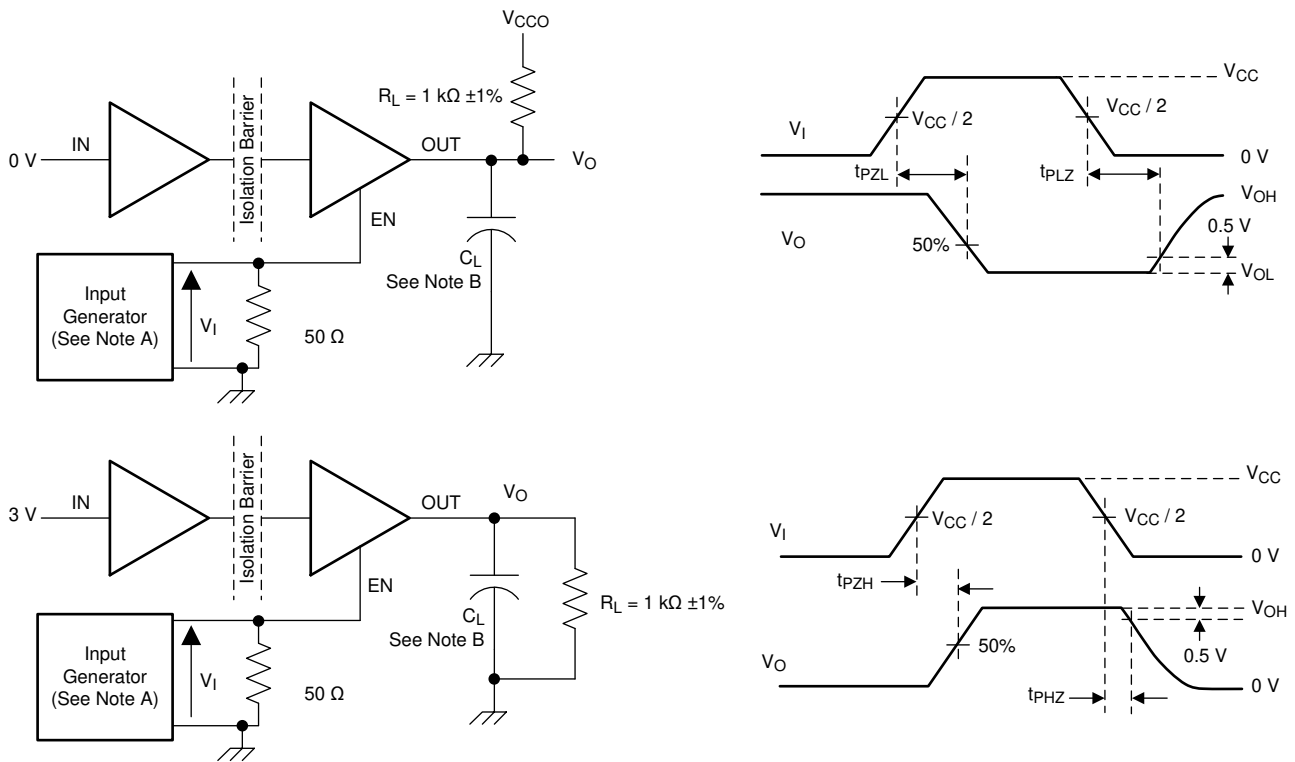

Copyright © 2016, Texas Instruments Incorporated

- A. The input pulse is supplied by a generator having the following characteristics: PRR \leq 10 kHz, 50% duty cycle, $t_r \leq$ 3 ns, $t_f \leq$ 3 ns, $Z_O = 50 \Omega$.
- B. $C_L = 15$ pF and includes instrumentation and fixture capacitance within $\pm 20\%$.

Figure 8-2. Enable/Disable Propagation Delay Time Test Circuit and Waveform

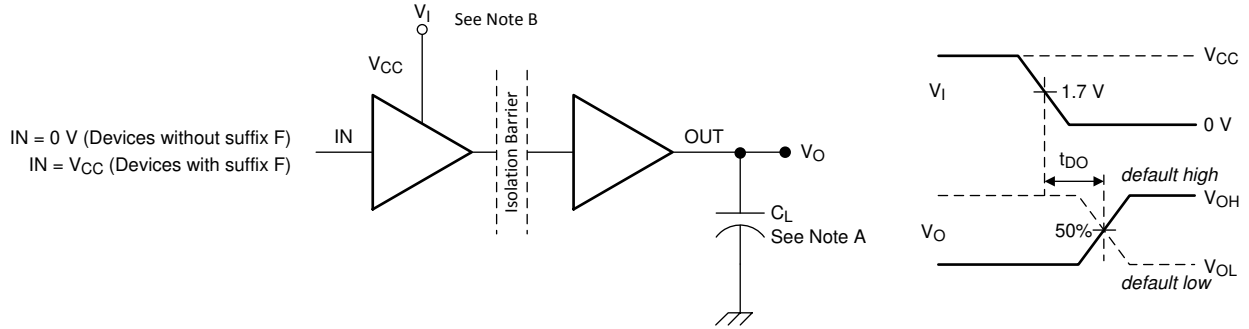

- A. $C_L = 15 \text{ pF}$ and includes instrumentation and fixture capacitance within $\pm 20\%$.
- B. Power Supply Ramp Rate = 10 mV/ns

Figure 8-3. Default Output Delay Time Test Circuit and Voltage Waveforms

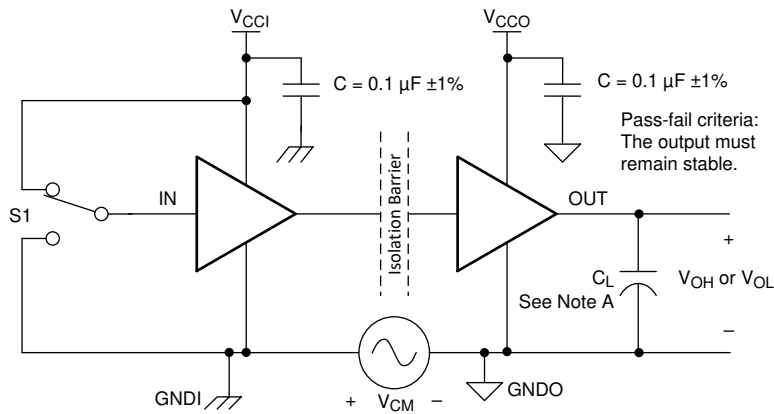

- A. $C_L = 15 \text{ pF}$ and includes instrumentation and fixture capacitance within $\pm 20\%$.

Figure 8-4. Common-Mode Transient Immunity Test Circuit

9 Detailed Description

9.1 Overview

The ISO773x-Q1 family of devices has an ON-OFF keying (OOK) modulation scheme to transmit the digital data across a silicon dioxide based isolation barrier. The transmitter sends a high frequency carrier across the barrier to represent one digital state and sends no signal to represent the other digital state. The receiver demodulates the signal after advanced signal conditioning and produces the output through a buffer stage. If the ENx pin is low then the output goes to high impedance. The ISO773x-Q1 family of devices also incorporates advanced circuit techniques to maximize the CMTI performance and minimize the radiated emissions due the high frequency carrier and IO buffer switching. The conceptual block diagram of a digital capacitive isolator, [Figure 9-1](#), shows a functional block diagram of a typical channel.

9.2 Functional Block Diagram

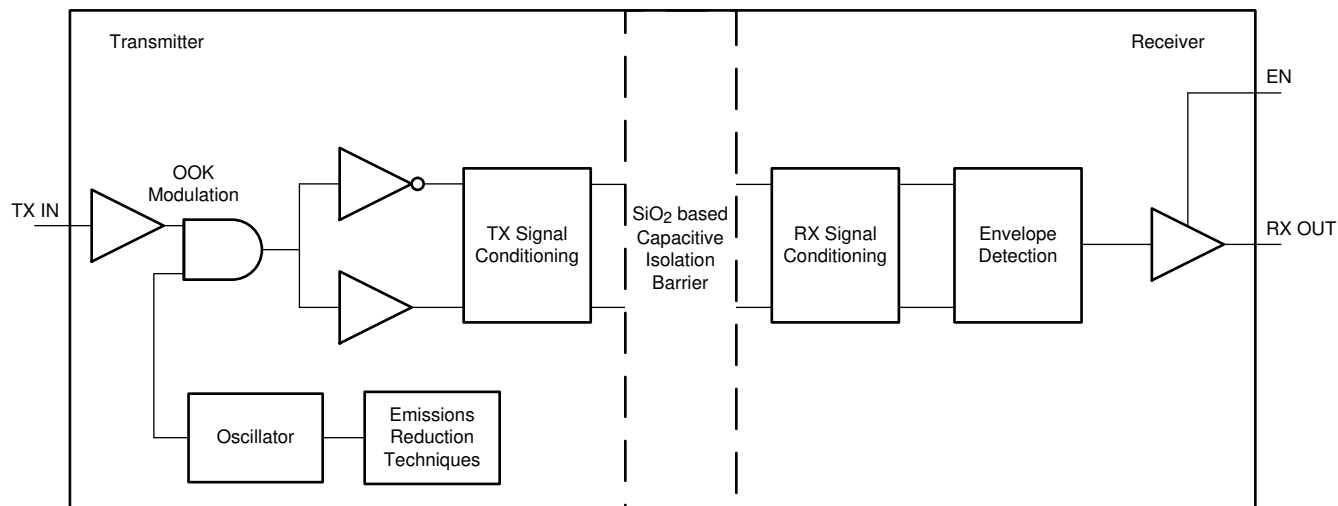

Copyright © 2016, Texas Instruments Incorporated

Figure 9-1. Conceptual Block Diagram of a Digital Capacitive Isolator

[Figure 9-2](#) shows a conceptual detail of how the ON-OFF keying scheme works.

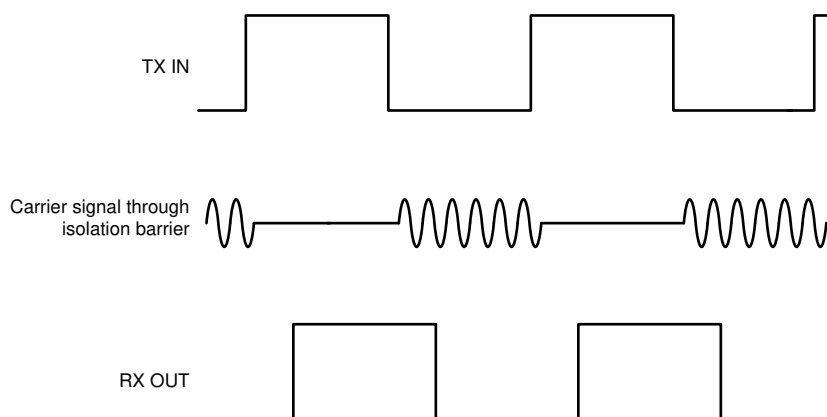

Figure 9-2. On-Off Keying (OOK) Based Modulation Scheme

9.3 Feature Description

Table 9-1 provides an overview of the device features.

Table 9-1. Device Features

PART NUMBER	CHANNEL DIRECTION	MAXIMUM DATA RATE	DEFAULT OUTPUT	PACKAGE	RATED ISOLATION ⁽¹⁾
ISO7730-Q1	3 Forward, 0 Reverse	100 Mbps	High	DW-16	5000 V _{RMS} / 8000 V _{PK}
				DBQ-16	3000 V _{RMS} / 4242 V _{PK}
ISO7730-Q1 with F suffix	3 Forward, 0 Reverse	100 Mbps	Low	DW-16	5000 V _{RMS} / 8000 V _{PK}
				DBQ-16	3000 V _{RMS} / 4242 V _{PK}
ISO7731-Q1	2 Forward, 1 Reverse	100 Mbps	High	DW-16	5000 V _{RMS} / 8000 V _{PK}
				DBQ-16	3000 V _{RMS} / 4242 V _{PK}
ISO7731-Q1 with F suffix	2 Forward, 1 Reverse	100 Mbps	Low	DW-16	5000 V _{RMS} / 8000 V _{PK}
				DBQ-16	3000 V _{RMS} / 4242 V _{PK}

(1) See [Section 7.7](#) for detailed isolation ratings.

9.3.1 Electromagnetic Compatibility (EMC) Considerations

Many applications in harsh industrial environment are sensitive to disturbances such as electrostatic discharge (ESD), electrical fast transient (EFT), surge and electromagnetic emissions. These electromagnetic disturbances are regulated by international standards such as IEC 61000-4-x and CISPR 22. Although system-level performance and reliability depends, to a large extent, on the application board design and layout, the ISO773x-Q1 family of devices incorporates many chip-level design improvements for overall system robustness. Some of these improvements include:

- Robust ESD protection cells for input and output signal pins and inter-chip bond pads.
- Low-resistance connectivity of ESD cells to supply and ground pins.
- Enhanced performance of high voltage isolation capacitor for better tolerance of ESD, EFT and surge events.
- Bigger on-chip decoupling capacitors to bypass undesirable high energy signals through a low impedance path.
- PMOS and NMOS devices isolated from each other by using guard rings to avoid triggering of parasitic SCRs.
- Reduced common mode currents across the isolation barrier by ensuring purely differential internal operation.

9.4 Device Functional Modes

Table 9-2 lists the functional modes for the ISO773x-Q1 devices.

Table 9-2. Function Table

V _{CCI} ⁽¹⁾	V _{CCO}	INPUT (IN _x) ⁽³⁾	OUTPUT ENABLE (EN _x)	OUTPUT (OUT _x)	COMMENTS
PU	PU	H	H or open	H	Normal Operation: A channel output assumes the logic state of its input.
		L	H or open	L	
		Open	H or open	Default	Default mode: When IN _x is open, the corresponding channel output goes to its default logic state. Default is <i>High</i> for ISO773x-Q1 and <i>Low</i> for ISO773x-Q1 with F suffix.
X	PU	X	L	Z	A low value of Output Enable causes the outputs to be high-impedance
PD	PU	X	H or open	Default	Default mode: When V _{CCI} is unpowered, a channel output assumes the logic state based on the selected default option. Default is <i>High</i> for ISO773x-Q1 and <i>Low</i> for ISO773x-Q1 with F suffix. When V _{CCI} transitions from unpowered to powered-up, a channel output assumes the logic state of its input. When V _{CCI} transitions from powered-up to unpowered, channel output assumes the selected default state.
X	PD	X	X	Undetermined	When V _{CCO} is unpowered, a channel output is undetermined ⁽²⁾ . When V _{CCO} transitions from unpowered to powered-up, a channel output assumes the logic state of its input

- (1) V_{CCI} = Input-side V_{CC}; V_{CCO} = Output-side V_{CC}; PU = Powered up (V_{CC} ≥ 2.25 V); PD = Powered down (V_{CC} ≤ 1.7 V); X = Irrelevant; H = High level; L = Low level ; Z = High Impedance
- (2) The outputs are in undetermined state when 1.7 V < V_{CCI}, V_{CCO} < 2.25 V.
- (3) A strongly driven input signal can weakly power the floating V_{CC} via an internal protection diode and cause undetermined output.

9.4.1 Device I/O Schematics

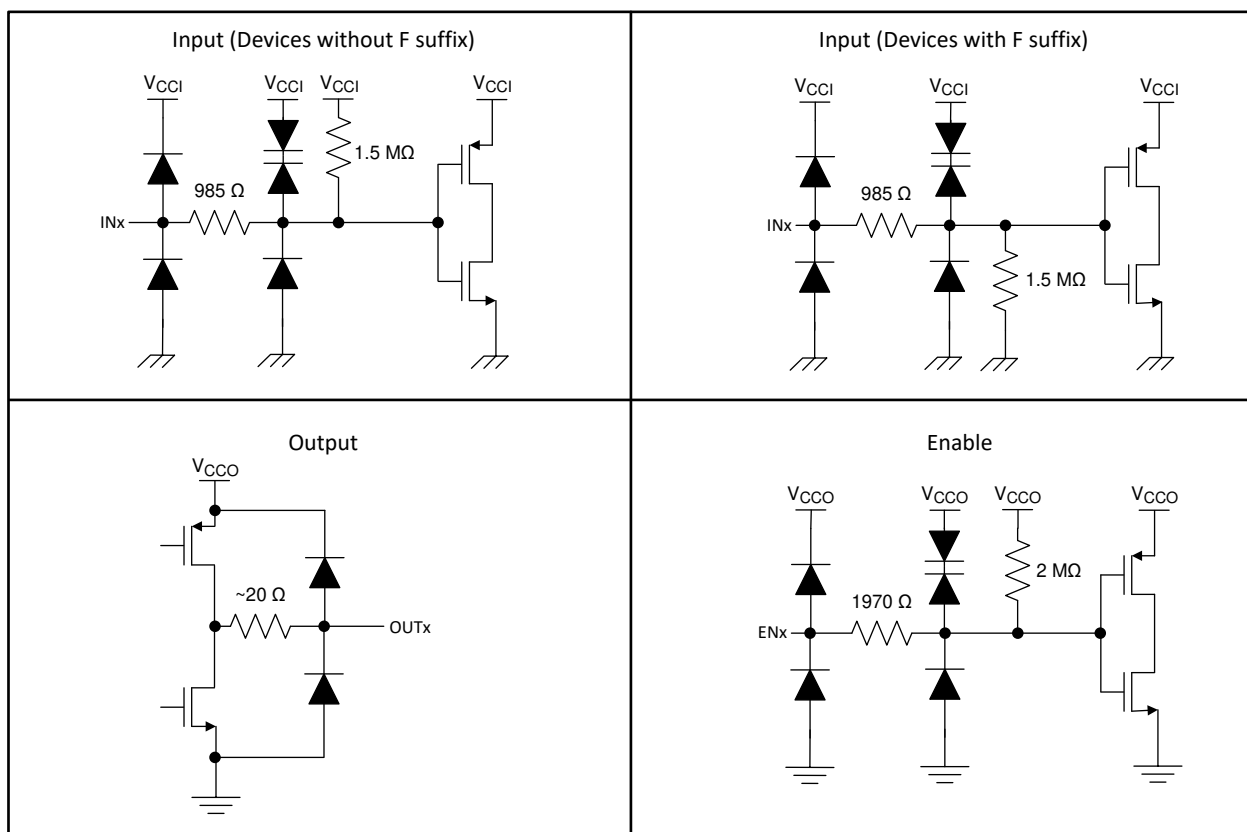

Copyright © 2016, Texas Instruments Incorporated

Figure 9-3. Device I/O Schematics

10 Application and Implementation

Note

Information in the following applications sections is not part of the TI component specification, and TI does not warrant its accuracy or completeness. TI's customers are responsible for determining suitability of components for their purposes. Customers should validate and test their design implementation to confirm system functionality.

10.1 Application Information

The ISO773x-Q1 devices are high-performance, triple-channel digital isolators. These devices come with enable pins on each side which can be used to put the respective outputs in high impedance for multi-master driving applications and reduce power consumption. The ISO773x-Q1 family of devices use single-ended CMOS-logic switching technology. The voltage range is from 2.25 V to 5.5 V for both supplies, V_{CC1} and V_{CC2} . When designing with digital isolators, keep in mind that because of the single-ended design structure, digital isolators do not conform to any specific interface standard and are only intended for isolating single-ended CMOS or TTL digital signal lines. The isolator is typically placed between the data controller (that is, μC or UART), and a data converter or a line transceiver, regardless of the interface type or standard.

10.2 Typical Application

The ISO7731-Q1 device combined with Texas Instruments' Piccolo™ microcontroller, analog-to-digital receiver, transformer driver, and voltage regulator can create an isolated serial peripheral interface (SPI) as shown in Figure 10-1.

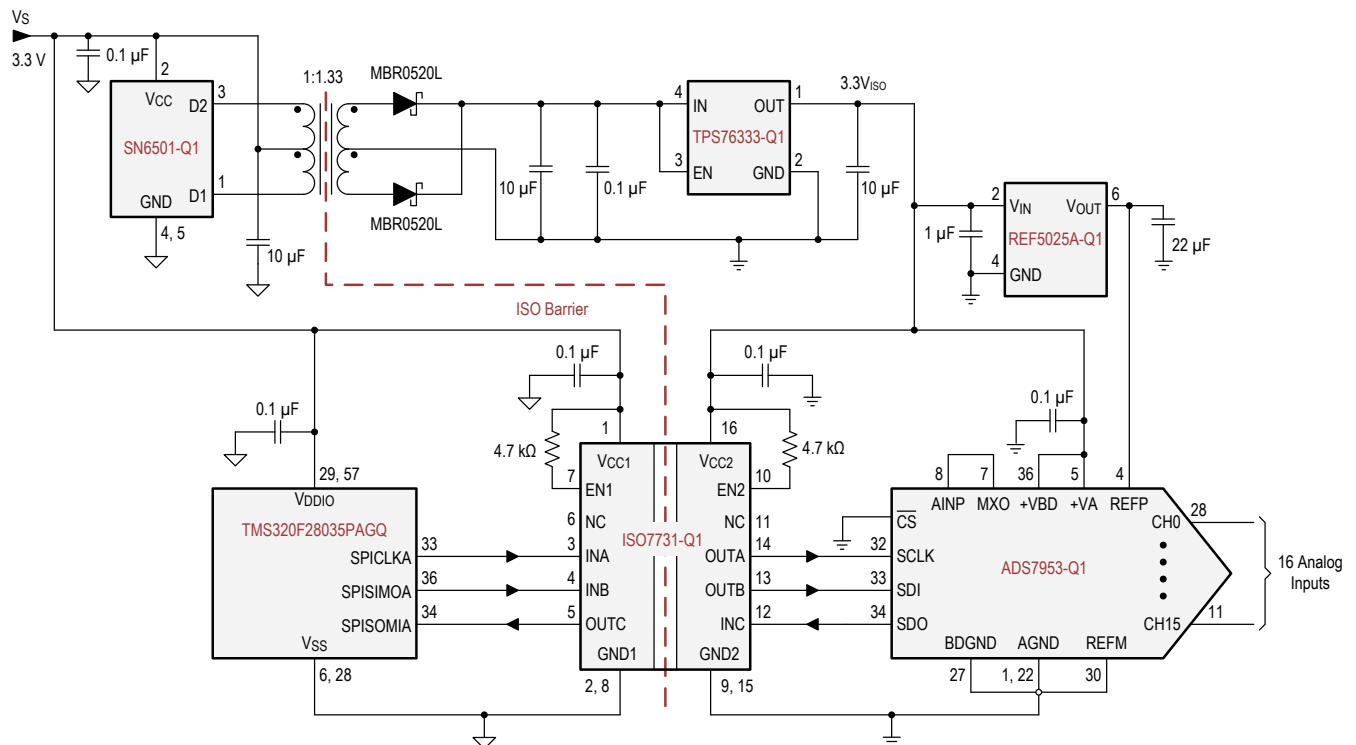

Copyright © 2016, Texas Instruments Incorporated

Multiple pins and discrete components are omitted for clarity.

Figure 10-1. Isolated SPI for an Analog Input Module With 16 Inputs and a Single Slave

10.2.1 Design Requirements

To design with these devices, use the parameters listed in [Table 10-1](#).

Table 10-1. Design Parameters

PARAMETER	VALUE
Supply voltage, V_{CC1} and V_{CC2}	2.25 to 5.5 V
Decoupling capacitor between V_{CC1} and GND1	0.1 μ F
Decoupling capacitor from V_{CC2} and GND2	0.1 μ F

10.2.2 Detailed Design Procedure

Unlike optocouplers, which require external components to improve performance, provide bias, or limit current, the ISO773x-Q1 family of devices only requires two external bypass capacitors to operate. [Figure 10-2](#) and [Figure 10-3](#) show the typical circuit hook-up for the devices.

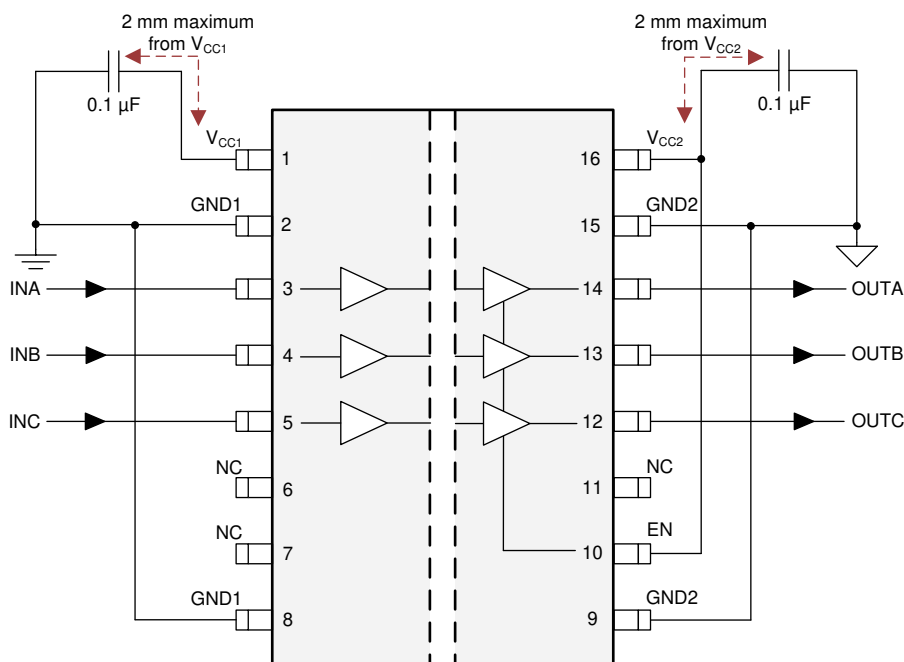

Figure 10-2. Typical ISO7730-Q1 Circuit Hook-Up

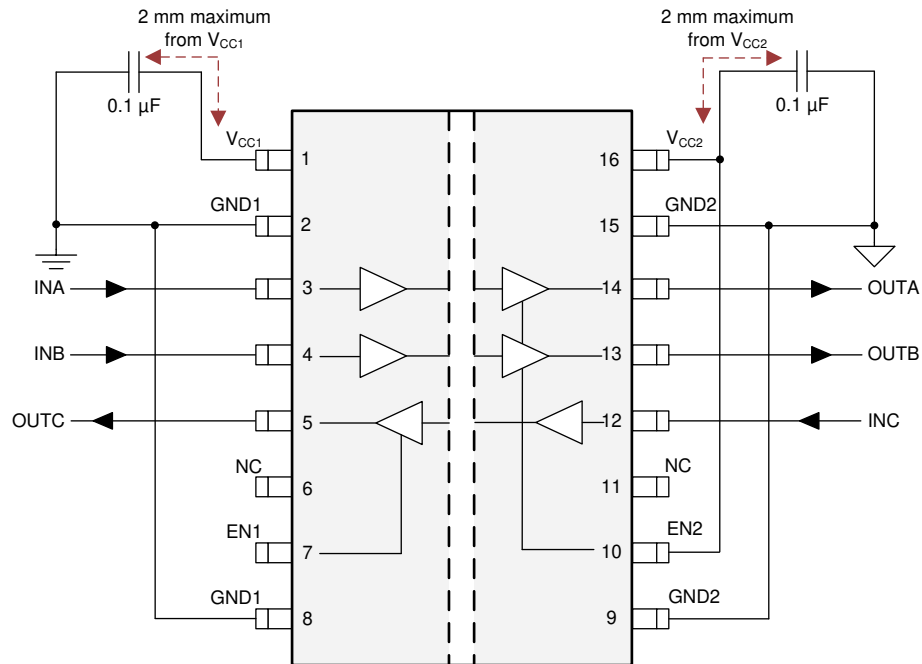
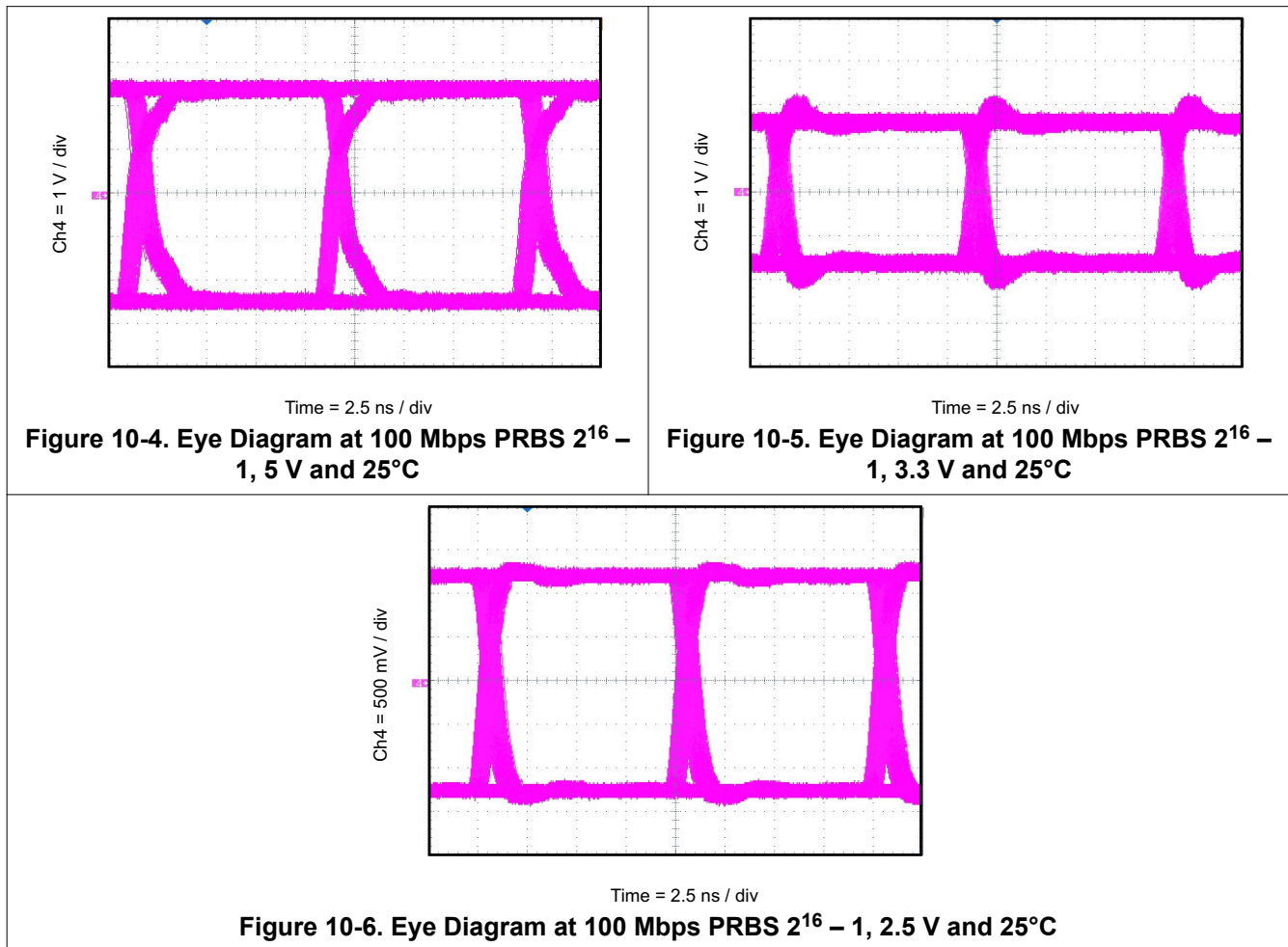

Figure 10-3. Typical ISO7731-Q1 Circuit Hook-Up

10.2.3 Application Curves

The following typical eye diagrams of the ISO773x-Q1 family of devices indicate low jitter and wide open eye at the maximum data rate of 100 Mbps.



10.2.3.1 Insulation Lifetime

Insulation lifetime projection data is collected by using industry-standard Time Dependent Dielectric Breakdown (TDDB) test method. In this test, all pins on each side of the barrier are tied together creating a two-terminal device and high voltage applied between the two sides; See [Figure 10-7](#) for TDDB test setup. The insulation breakdown data is collected at various high voltages switching at 60 Hz over temperature. For reinforced insulation, VDE standard requires the use of TDDB projection line with failure rate of less than 1 part per million (ppm). Even though the expected minimum insulation lifetime is 20 years at the specified working isolation voltage, VDE reinforced certification requires additional safety margin of 20% for working voltage and 87.5% for lifetime which translates into minimum required insulation lifetime of 37.5 years at a working voltage that's 20% higher than the specified value.

[Figure 10-8](#) shows the intrinsic capability of the isolation barrier to withstand high voltage stress over its lifetime. Based on the TDDB data, the intrinsic capability of the insulation is 1500 V_{RMS} with a lifetime of 135 years. Other factors, such as package size, pollution degree, material group, etc. can further limit the working voltage of the component. The working voltage of DW-16 package is specified upto 1500 V_{RMS} and DBQ-16 package up to 400 V_{RMS}. At the lower working voltages, the corresponding insulation lifetime is much longer than 135 years.

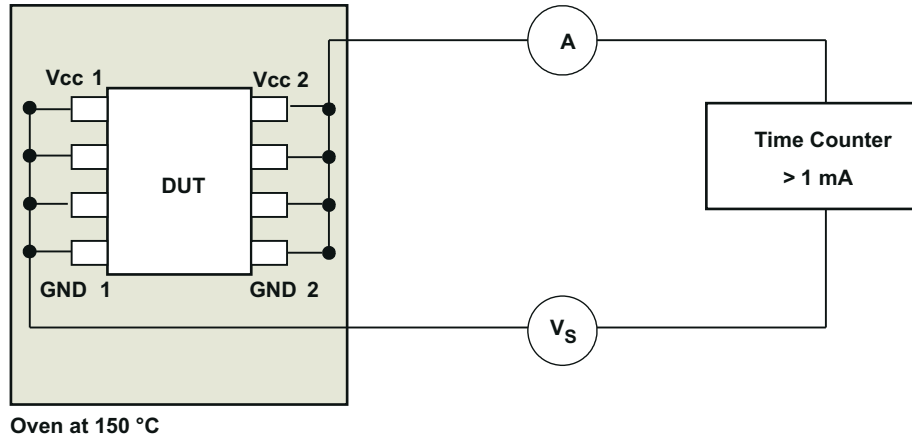

Figure 10-7. Test Setup for Insulation Lifetime Measurement

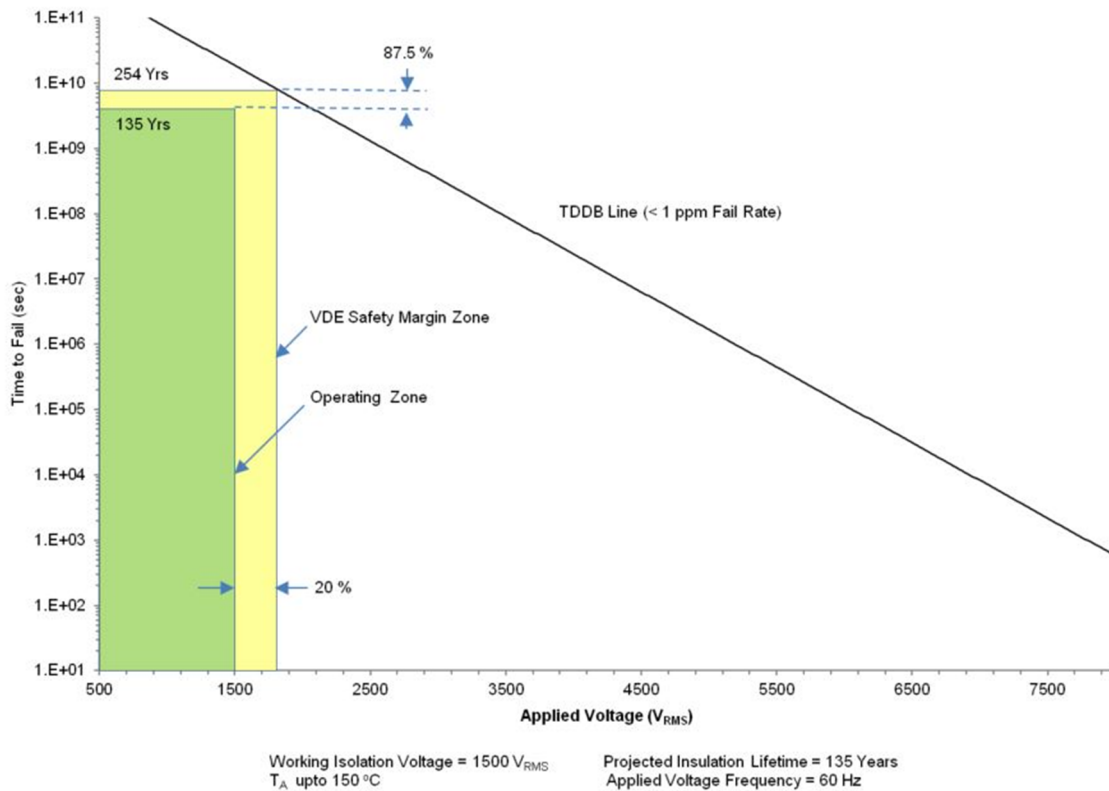

Figure 10-8. Insulation Lifetime Projection Data

11 Power Supply Recommendations

To help ensure reliable operation at data rates and supply voltages, a 0.1- μ F bypass capacitor is recommended at the input and output supply pins (V_{CC1} and V_{CC2}). The capacitors should be placed as close to the supply pins as possible. If only a single primary-side power supply is available in an application, isolated power can be generated for the secondary-side with the help of a transformer driver such as Texas Instruments' [SN6501-Q1](#). For such applications, detailed power supply design and transformer selection recommendations are available in the [SN6501-Q1 Transformer Driver for Isolated Power Supplies data sheet](#).

12 Layout

12.1 Layout Guidelines

A minimum of four layers is required to accomplish a low EMI PCB design (see [Figure 12-1](#)). Layer stacking should be in the following order (top-to-bottom): high-speed signal layer, ground plane, power plane and low-frequency signal layer.

- Routing the high-speed traces on the top layer avoids the use of vias (and the introduction of their inductances) and allows for clean interconnects between the isolator and the transmitter and receiver circuits of the data link.
- Placing a solid ground plane next to the high-speed signal layer establishes controlled impedance for transmission line interconnects and provides an excellent low-inductance path for the return current flow.
- Placing the power plane next to the ground plane creates additional high-frequency bypass capacitance of approximately 100 pF/inch².
- Routing the slower speed control signals on the bottom layer allows for greater flexibility as these signal links usually have margin to tolerate discontinuities such as vias.

If an additional supply voltage plane or signal layer is needed, add a second power or ground plane system to the stack to keep it symmetrical. This makes the stack mechanically stable and prevents it from warping. Also the power and ground plane of each power system can be placed closer together, thus increasing the high-frequency bypass capacitance significantly.

For detailed layout recommendations, refer to the [Digital Isolator Design Guide](#).

12.1.1 PCB Material

For digital circuit boards operating below 150 Mbps, (or rise and fall times higher than 1 ns), and trace lengths of up to 10 inches, use standard FR-4 UL94V-0 printed circuit boards. This PCB is preferred over cheaper alternatives due to its lower dielectric losses at high frequencies, less moisture absorption, greater strength and stiffness, and self-extinguishing flammability-characteristics.

12.2 Layout Example

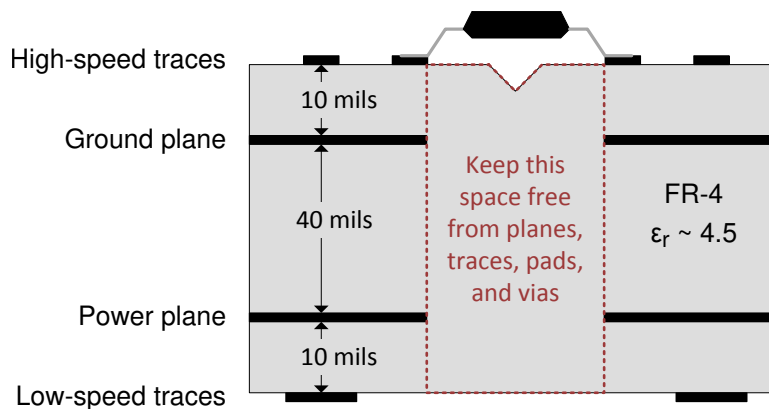

Figure 12-1. Layout Example Schematic

13 Device and Documentation Support

13.1 Documentation Support

13.1.1 Related Documentation

For related documentation, see the following:

- Texas Instruments, [Digital Isolator Design Guide](#)
- Texas Instruments, [Isolation Glossary](#)
- Texas Instruments, [How to use isolation to improve ESD, EFT, and Surge immunity in industrial systems application report](#)
- Texas Instruments, [REF50xxA-Q1 Low-Noise, Very Low Drift, Precision Voltage Reference data sheet](#)
- Texas Instruments, [SN6501-Q1 Transformer Driver for Isolated Power Supplies data sheet](#)
- Texas Instruments, [TPS76333-Q1 Low-Power 150-mA Low-Dropout Linear Regulators data sheet](#)
- Texas Instruments, [TMS320F28035 Piccolo™ Microcontrollers data sheet](#)

13.2 Related Links

The table below lists quick access links. Categories include technical documents, support and community resources, tools and software, and quick access to sample or buy.

Table 13-1. Related Links

PARTS	PRODUCT FOLDER	ORDER NOW	TECHNICAL DOCUMENTS	TOOLS & SOFTWARE	SUPPORT & COMMUNITY
ISO7730-Q1	Click here	Click here	Click here	Click here	Click here
ISO7731-Q1	Click here	Click here	Click here	Click here	Click here

13.3 Receiving Notification of Documentation Updates

To receive notification of documentation updates, navigate to the device product folder on ti.com. In the upper right corner, click on *Alert me* to register and receive a weekly digest of any product information that has changed. For change details, review the revision history included in any revised document.

13.4 Support Resources

TI E2E™ [support forums](#) are an engineer's go-to source for fast, verified answers and design help — straight from the experts. Search existing answers or ask your own question to get the quick design help you need.

Linked content is provided "AS IS" by the respective contributors. They do not constitute TI specifications and do not necessarily reflect TI's views; see TI's [Terms of Use](#).

13.5 Trademarks

Piccolo™ is a trademark of Texas Instruments.

TI E2E™ is a trademark of Texas Instruments.

All trademarks are the property of their respective owners.

13.6 Electrostatic Discharge Caution



This integrated circuit can be damaged by ESD. Texas Instruments recommends that all integrated circuits be handled with appropriate precautions. Failure to observe proper handling and installation procedures can cause damage.

ESD damage can range from subtle performance degradation to complete device failure. Precision integrated circuits may be more susceptible to damage because very small parametric changes could cause the device not to meet its published specifications.

13.7 Glossary

TI Glossary This glossary lists and explains terms, acronyms, and definitions.

14 Mechanical, Packaging, and Orderable Information

The following pages include mechanical, packaging, and orderable information. This information is the most current data available for the designated devices. This data is subject to change without notice and revision of this document. For browser-based versions of this data sheet, refer to the left-hand navigation.

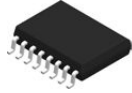

DW0016B

PACKAGE OUTLINE
SOIC - 2.65 mm max height

SOIC

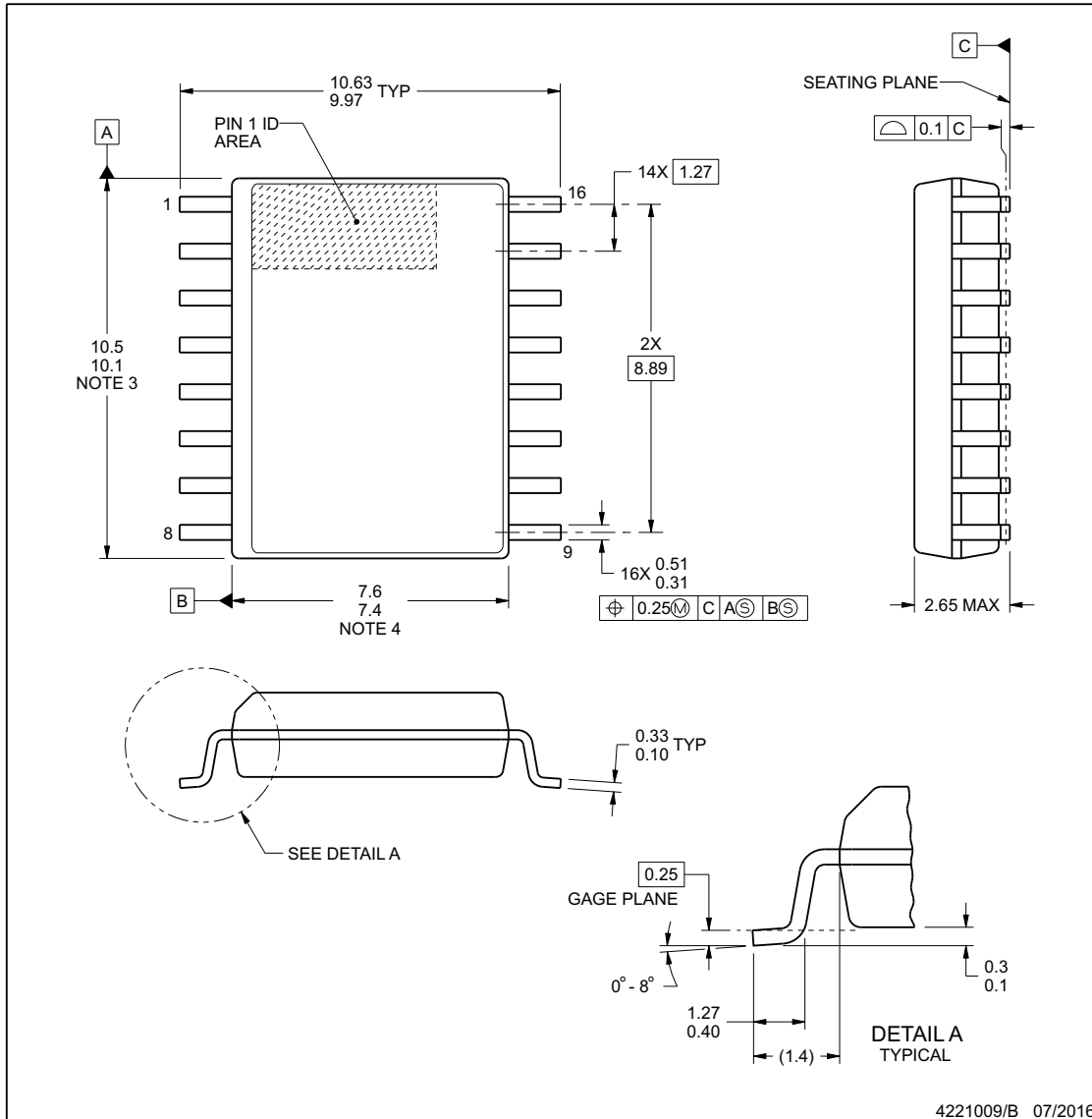

NOTES:

1. All linear dimensions are in millimeters. Dimensions in parenthesis are for reference only. Dimensioning and tolerancing per ASME Y14.5M.
2. This drawing is subject to change without notice.
3. This dimension does not include mold flash, protrusions, or gate burrs. Mold flash, protrusions, or gate burrs shall not exceed 0.15 mm, per side.
4. This dimension does not include interlead flash. Interlead flash shall not exceed 0.25 mm, per side.
5. Reference JEDEC registration MS-013.

www.ti.com

EXAMPLE BOARD LAYOUT

DW0016B

SOIC - 2.65 mm max height

SOIC

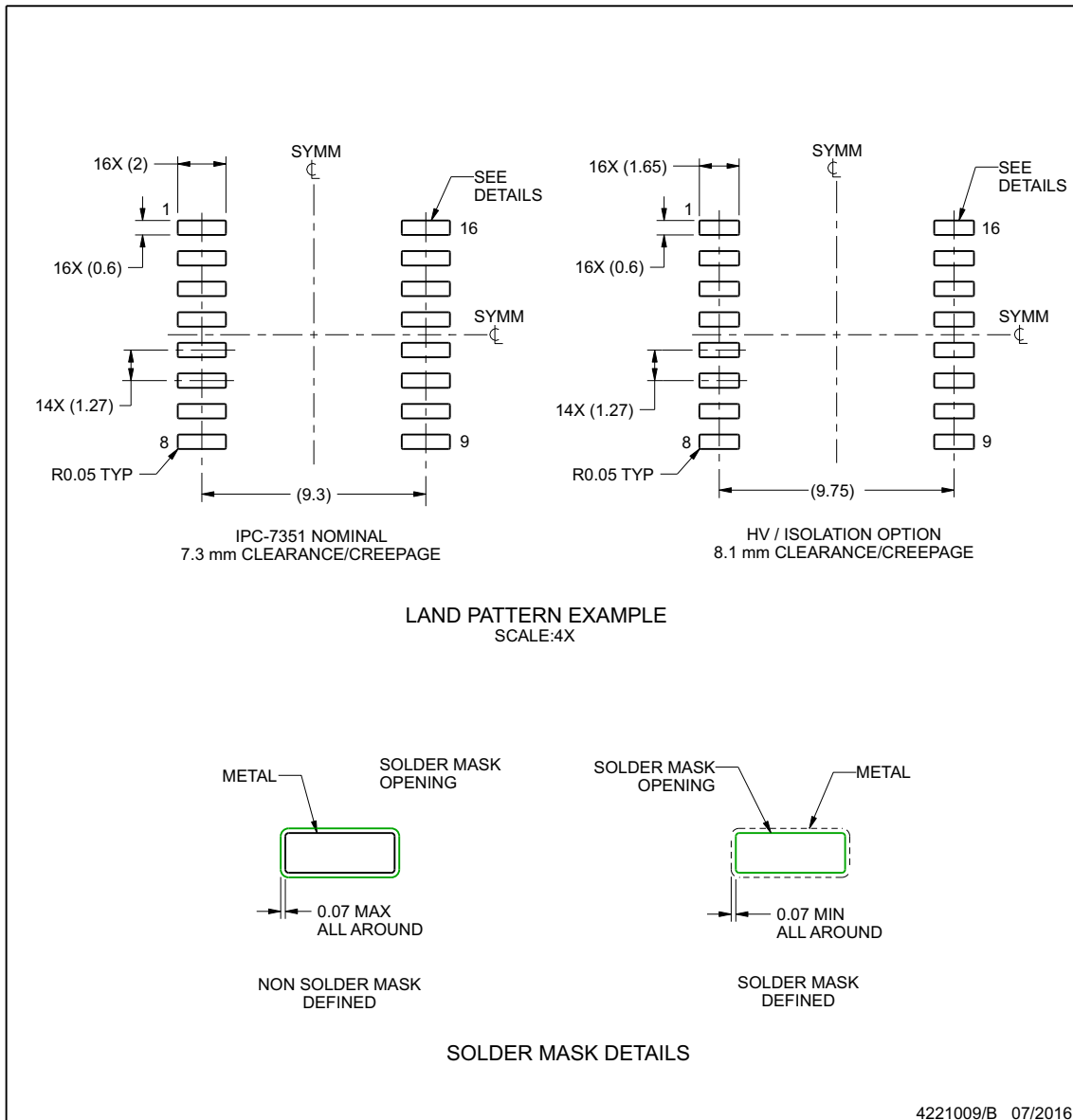

NOTES: (continued)

- 6. Publication IPC-7351 may have alternate designs.
- 7. Solder mask tolerances between and around signal pads can vary based on board fabrication site.

www.ti.com

EXAMPLE STENCIL DESIGN

DW0016B

SOIC - 2.65 mm max height

SOIC

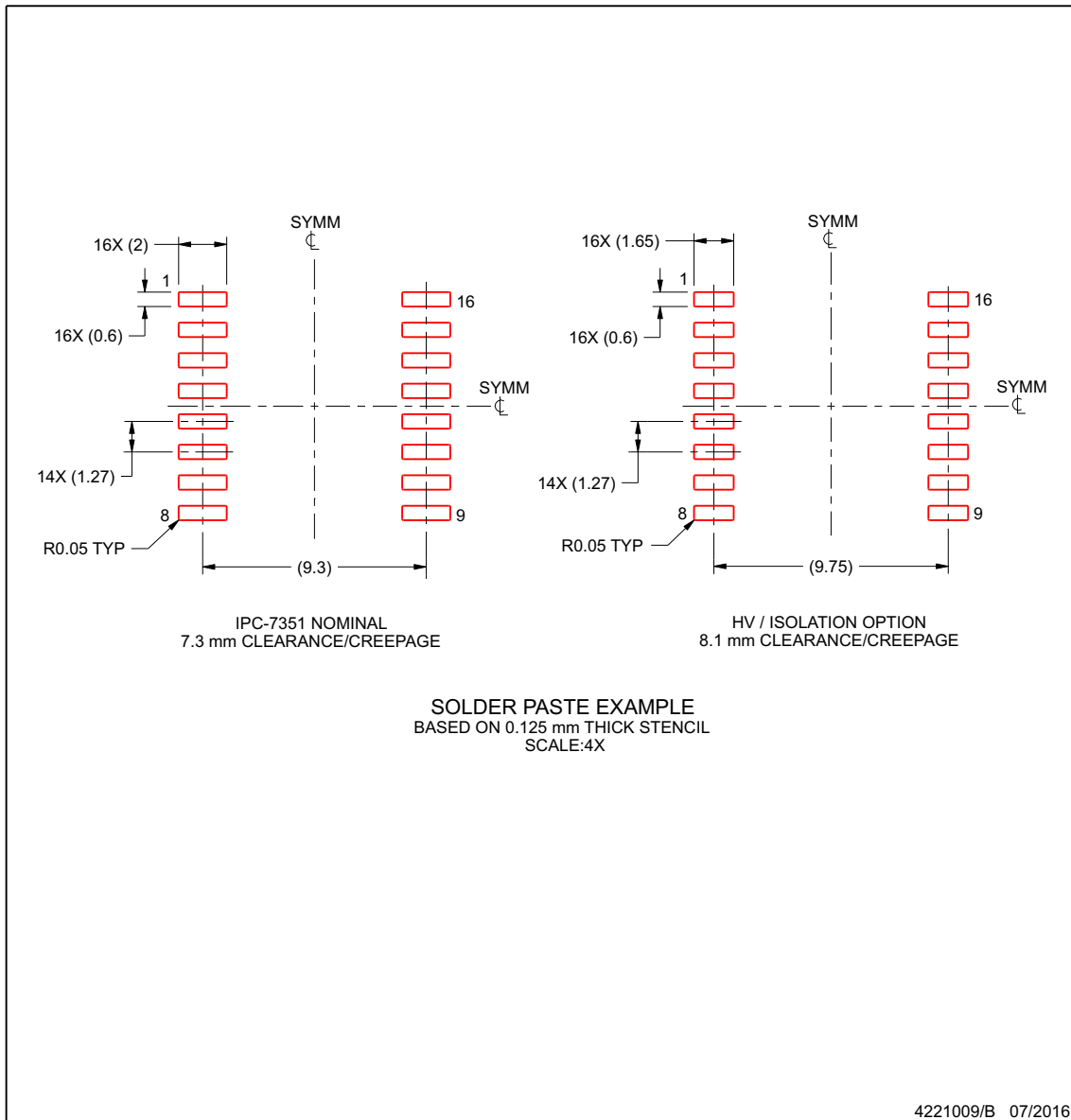

NOTES: (continued)

- 8. Laser cutting apertures with trapezoidal walls and rounded corners may offer better paste release. IPC-7525 may have alternate design recommendations.
- 9. Board assembly site may have different recommendations for stencil design.

www.ti.com

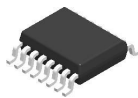

DBQ0016A

PACKAGE OUTLINE
SSOP - 1.75 mm max height

SHRINK SMALL-OUTLINE PACKAGE

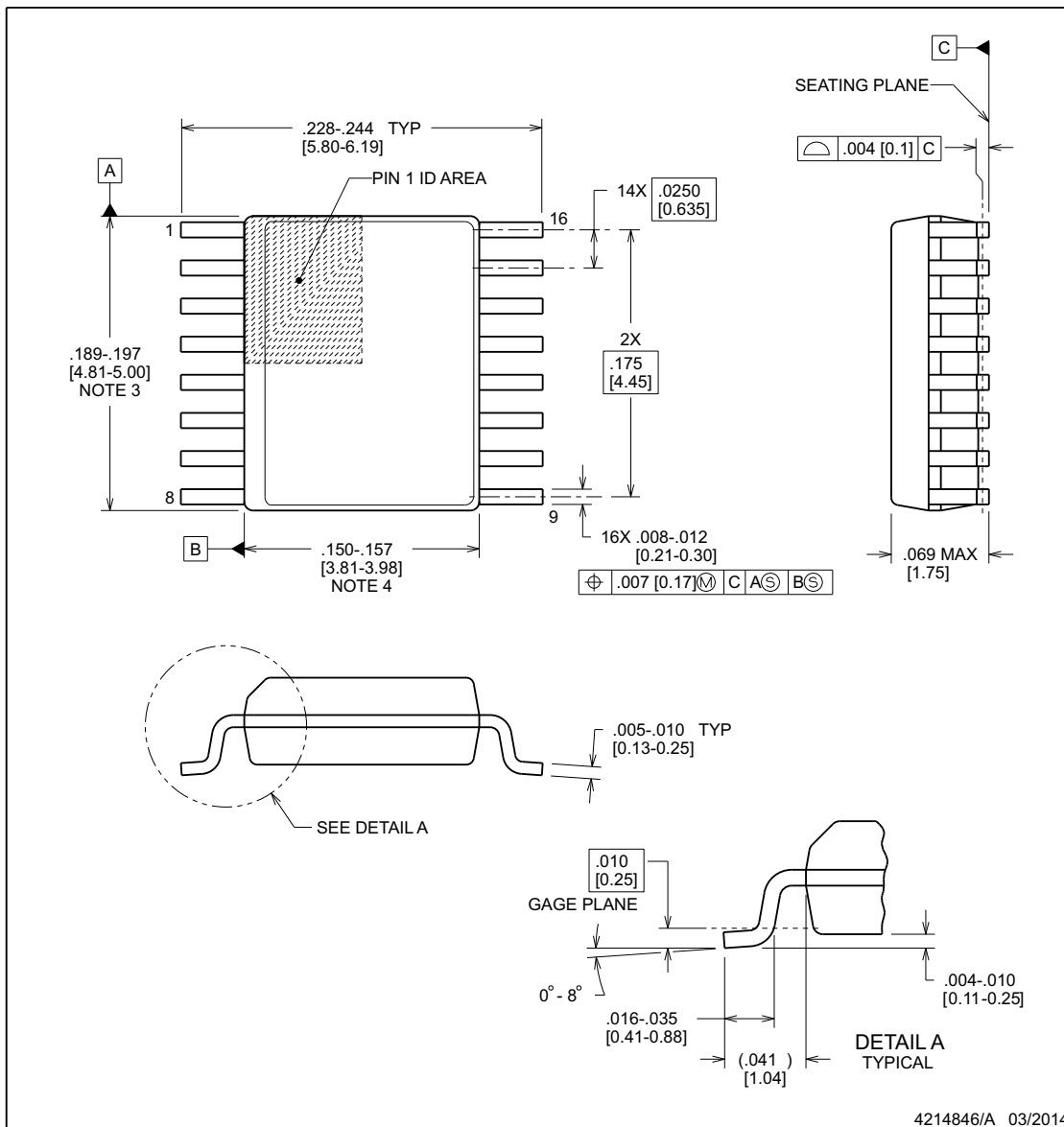

NOTES:

1. Linear dimensions are in inches [millimeters]. Dimensions in parenthesis are for reference only. Controlling dimensions are in inches. Dimensioning and tolerancing per ASME Y14.5M.
2. This drawing is subject to change without notice.
3. This dimension does not include mold flash, protrusions, or gate burrs. Mold flash, protrusions, or gate burrs shall not exceed .006 inch, per side.
4. This dimension does not include interlead flash.
5. Reference JEDEC registration MO-137, variation AB.

www.ti.com

EXAMPLE BOARD LAYOUT

DBQ0016A

SSOP - 1.75 mm max height

SHRINK SMALL-OUTLINE PACKAGE

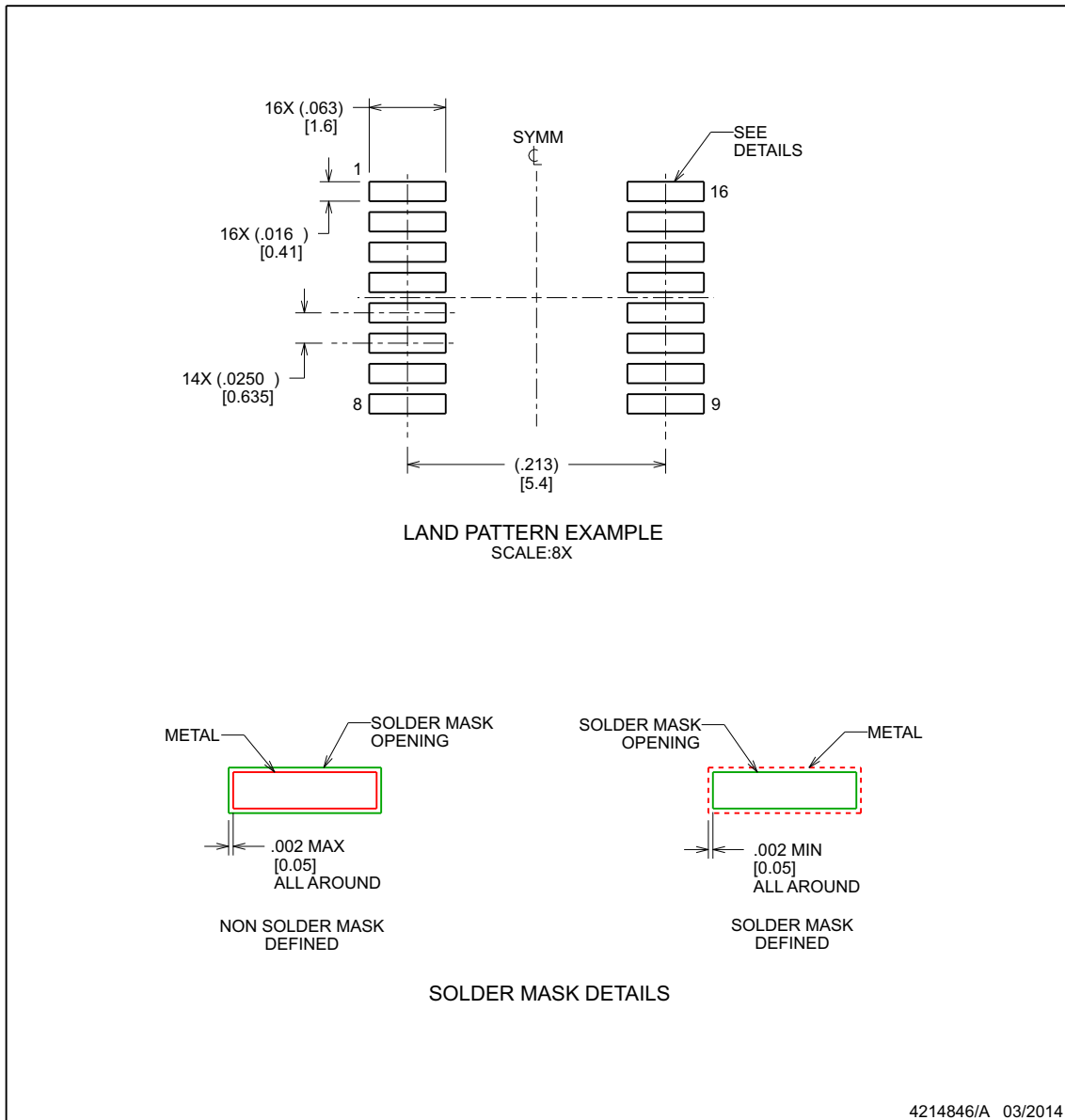

4214846/A 03/2014

NOTES: (continued)

- 6. Publication IPC-7351 may have alternate designs.
- 7. Solder mask tolerances between and around signal pads can vary based on board fabrication site.

www.ti.com

EXAMPLE STENCIL DESIGN

DBQ0016A

SSOP - 1.75 mm max height

SHRINK SMALL-OUTLINE PACKAGE

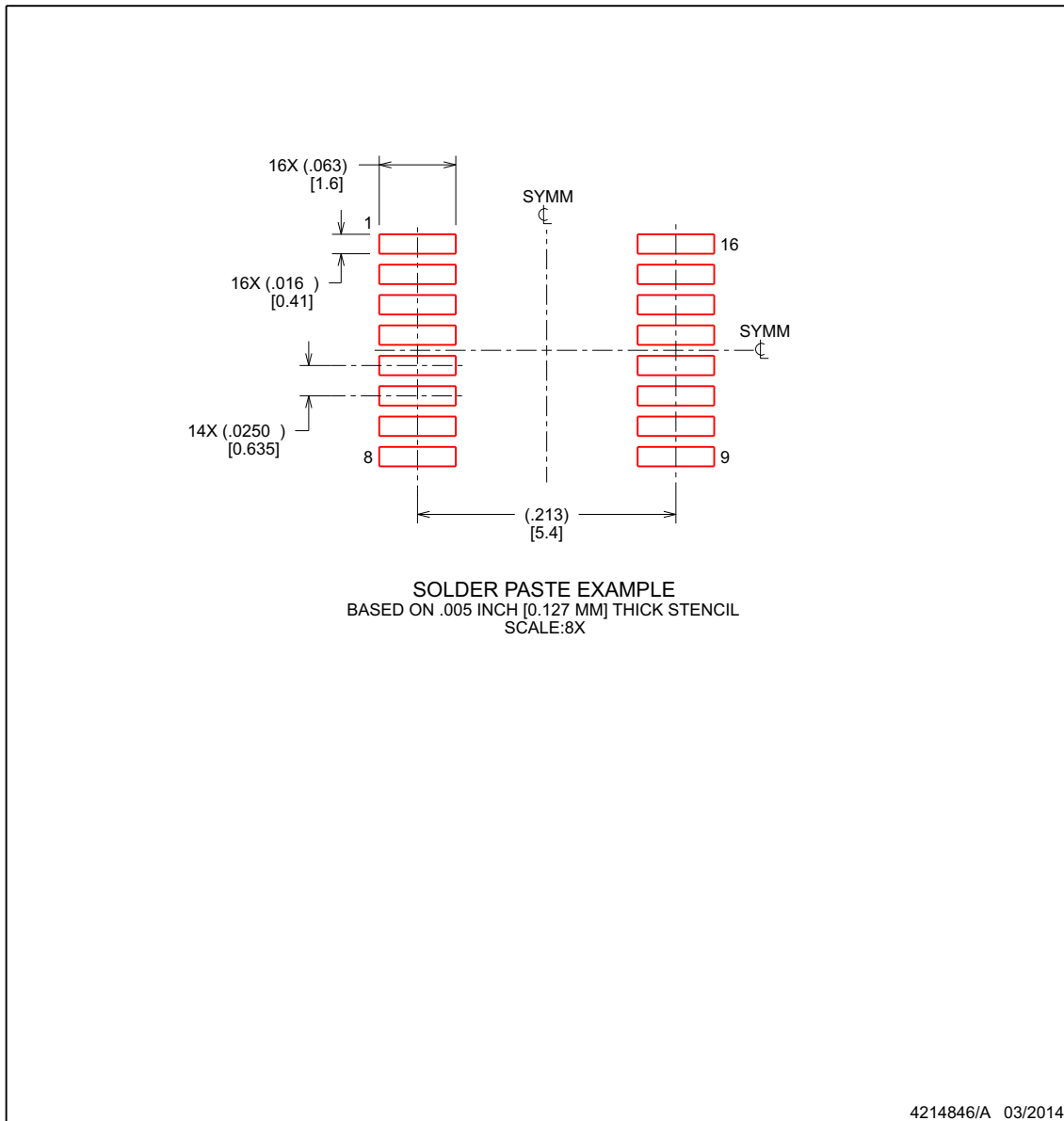

NOTES: (continued)

8. Laser cutting apertures with trapezoidal walls and rounded corners may offer better paste release. IPC-7525 may have alternate design recommendations.
9. Board assembly site may have different recommendations for stencil design.

www.ti.com

PACKAGING INFORMATION

Orderable Device	Status (1)	Package Type	Package Drawing	Pins	Package Qty	Eco Plan (2)	Lead finish/ Ball material (6)	MSL Peak Temp (3)	Op Temp (°C)	Device Marking (4/5)	Samples
ISO7730FQDBQQ1	ACTIVE	SSOP	DBQ	16	75	Green (RoHS & no Sb/Br)	NIPDAU	Level-2-260C-1 YEAR	-40 to 125	7730FQ	Samples
ISO7730FQDBQRQ1	ACTIVE	SSOP	DBQ	16	2500	Green (RoHS & no Sb/Br)	NIPDAU	Level-2-260C-1 YEAR	-40 to 125	7730FQ	Samples
ISO7730FQDWQ1	ACTIVE	SOIC	DW	16	40	Green (RoHS & no Sb/Br)	NIPDAU	Level-2-260C-1 YEAR	-40 to 125	ISO7730FQ	Samples
ISO7730FQDWRQ1	ACTIVE	SOIC	DW	16	2000	Green (RoHS & no Sb/Br)	NIPDAU	Level-2-260C-1 YEAR	-40 to 125	ISO7730FQ	Samples
ISO7730QDBQQ1	ACTIVE	SSOP	DBQ	16	75	Green (RoHS & no Sb/Br)	NIPDAU	Level-2-260C-1 YEAR	-40 to 125	7730Q	Samples
ISO7730QDBQRQ1	ACTIVE	SSOP	DBQ	16	2500	Green (RoHS & no Sb/Br)	NIPDAU	Level-2-260C-1 YEAR	-40 to 125	7730Q	Samples
ISO7730QDWQ1	ACTIVE	SOIC	DW	16	40	Green (RoHS & no Sb/Br)	NIPDAU	Level-2-260C-1 YEAR	-40 to 125	ISO7730Q	Samples
ISO7730QDWRQ1	ACTIVE	SOIC	DW	16	2000	Green (RoHS & no Sb/Br)	NIPDAU	Level-2-260C-1 YEAR	-40 to 125	ISO7730Q	Samples
ISO7731FQDBQQ1	ACTIVE	SSOP	DBQ	16	75	Green (RoHS & no Sb/Br)	NIPDAU	Level-2-260C-1 YEAR	-40 to 125	7731FQ	Samples
ISO7731FQDBQRQ1	ACTIVE	SSOP	DBQ	16	2500	Green (RoHS & no Sb/Br)	NIPDAU	Level-2-260C-1 YEAR	-40 to 125	7731FQ	Samples
ISO7731FQDWQ1	ACTIVE	SOIC	DW	16	40	Green (RoHS & no Sb/Br)	NIPDAU	Level-2-260C-1 YEAR	-40 to 125	ISO7731FQ	Samples
ISO7731FQDWRQ1	ACTIVE	SOIC	DW	16	2000	Green (RoHS & no Sb/Br)	NIPDAU	Level-2-260C-1 YEAR	-40 to 125	ISO7731FQ	Samples
ISO7731QDBQQ1	ACTIVE	SSOP	DBQ	16	75	Green (RoHS & no Sb/Br)	NIPDAU	Level-2-260C-1 YEAR	-40 to 125	7731Q	Samples
ISO7731QDBQRQ1	ACTIVE	SSOP	DBQ	16	2500	Green (RoHS & no Sb/Br)	NIPDAU	Level-2-260C-1 YEAR	-40 to 125	7731Q	Samples
ISO7731QDWQ1	ACTIVE	SOIC	DW	16	40	Green (RoHS & no Sb/Br)	NIPDAU	Level-2-260C-1 YEAR	-40 to 125	ISO7731Q	Samples
ISO7731QDWRQ1	ACTIVE	SOIC	DW	16	2000	Green (RoHS & no Sb/Br)	NIPDAU	Level-2-260C-1 YEAR	-40 to 125	ISO7731Q	Samples

⁽¹⁾ The marketing status values are defined as follows:

ACTIVE: Product device recommended for new designs.

LIFEBUY: TI has announced that the device will be discontinued, and a lifetime-buy period is in effect.

NRND: Not recommended for new designs. Device is in production to support existing customers, but TI does not recommend using this part in a new design.

PREVIEW: Device has been announced but is not in production. Samples may or may not be available.

OBSOLETE: TI has discontinued the production of the device.

⁽²⁾ **RoHS:** TI defines "RoHS" to mean semiconductor products that are compliant with the current EU RoHS requirements for all 10 RoHS substances, including the requirement that RoHS substance do not exceed 0.1% by weight in homogeneous materials. Where designed to be soldered at high temperatures, "RoHS" products are suitable for use in specified lead-free processes. TI may reference these types of products as "Pb-Free".

RoHS Exempt: TI defines "RoHS Exempt" to mean products that contain lead but are compliant with EU RoHS pursuant to a specific EU RoHS exemption.

Green: TI defines "Green" to mean the content of Chlorine (Cl) and Bromine (Br) based flame retardants meet JS709B low halogen requirements of ≤ 1000 ppm threshold. Antimony trioxide based flame retardants must also meet the ≤ 1000 ppm threshold requirement.

⁽³⁾ MSL, Peak Temp. - The Moisture Sensitivity Level rating according to the JEDEC industry standard classifications, and peak solder temperature.

⁽⁴⁾ There may be additional marking, which relates to the logo, the lot trace code information, or the environmental category on the device.

⁽⁵⁾ Multiple Device Markings will be inside parentheses. Only one Device Marking contained in parentheses and separated by a "~" will appear on a device. If a line is indented then it is a continuation of the previous line and the two combined represent the entire Device Marking for that device.

⁽⁶⁾ Lead finish/Ball material - Orderable Devices may have multiple material finish options. Finish options are separated by a vertical ruled line. Lead finish/Ball material values may wrap to two lines if the finish value exceeds the maximum column width.

Important Information and Disclaimer: The information provided on this page represents TI's knowledge and belief as of the date that it is provided. TI bases its knowledge and belief on information provided by third parties, and makes no representation or warranty as to the accuracy of such information. Efforts are underway to better integrate information from third parties. TI has taken and continues to take reasonable steps to provide representative and accurate information but may not have conducted destructive testing or chemical analysis on incoming materials and chemicals. TI and TI suppliers consider certain information to be proprietary, and thus CAS numbers and other limited information may not be available for release.

In no event shall TI's liability arising out of such information exceed the total purchase price of the TI part(s) at issue in this document sold by TI to Customer on an annual basis.

OTHER QUALIFIED VERSIONS OF ISO7730-Q1, ISO7731-Q1 :

- Catalog: [ISO7730](#), [ISO7731](#)

NOTE: Qualified Version Definitions:

- Catalog - TI's standard catalog product

TAPE AND REEL INFORMATION



QUADRANT ASSIGNMENTS FOR PIN 1 ORIENTATION IN TAPE

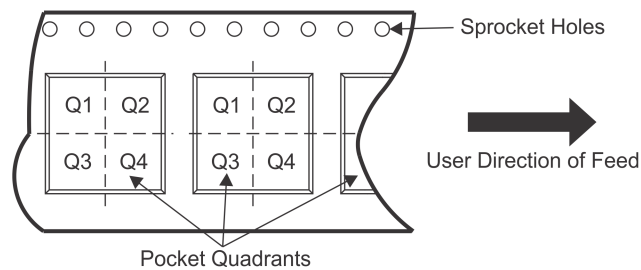

*All dimensions are nominal

Device	Package Type	Package Drawing	Pins	SPQ	Reel Diameter (mm)	Reel Width W1 (mm)	A0 (mm)	B0 (mm)	K0 (mm)	P1 (mm)	W (mm)	Pin1 Quadrant
ISO7730FQDBQRQ1	SSOP	DBQ	16	2500	330.0	12.4	6.4	5.2	2.1	8.0	12.0	Q1
ISO7730FQDWRQ1	SOIC	DW	16	2000	330.0	16.4	10.75	10.7	2.7	12.0	16.0	Q1
ISO7730QDBQRQ1	SSOP	DBQ	16	2500	330.0	12.4	6.4	5.2	2.1	8.0	12.0	Q1
ISO7730QDWRQ1	SOIC	DW	16	2000	330.0	16.4	10.75	10.7	2.7	12.0	16.0	Q1
ISO7731FQDBQRQ1	SSOP	DBQ	16	2500	330.0	12.4	6.4	5.2	2.1	8.0	12.0	Q1
ISO7731FQDWRQ1	SOIC	DW	16	2000	330.0	16.4	10.75	10.7	2.7	12.0	16.0	Q1
ISO7731QDBQRQ1	SSOP	DBQ	16	2500	330.0	12.4	6.4	5.2	2.1	8.0	12.0	Q1
ISO7731QDWRQ1	SOIC	DW	16	2000	330.0	16.4	10.75	10.7	2.7	12.0	16.0	Q1

TAPE AND REEL BOX DIMENSIONS

*All dimensions are nominal

Device	Package Type	Package Drawing	Pins	SPQ	Length (mm)	Width (mm)	Height (mm)
ISO7730FQDBQRQ1	SSOP	DBQ	16	2500	350.0	350.0	43.0
ISO7730FQDWRQ1	SOIC	DW	16	2000	350.0	350.0	43.0
ISO7730QDBQRQ1	SSOP	DBQ	16	2500	350.0	350.0	43.0
ISO7730QDWRQ1	SOIC	DW	16	2000	350.0	350.0	43.0
ISO7731FQDBQRQ1	SSOP	DBQ	16	2500	350.0	350.0	43.0
ISO7731FQDWRQ1	SOIC	DW	16	2000	350.0	350.0	43.0
ISO7731QDBQRQ1	SSOP	DBQ	16	2500	350.0	350.0	43.0
ISO7731QDWRQ1	SOIC	DW	16	2000	350.0	350.0	43.0

GENERIC PACKAGE VIEW

DW 16

SOIC - 2.65 mm max height

7.5 x 10.3, 1.27 mm pitch

SMALL OUTLINE INTEGRATED CIRCUIT

This image is a representation of the package family, actual package may vary.
Refer to the product data sheet for package details.

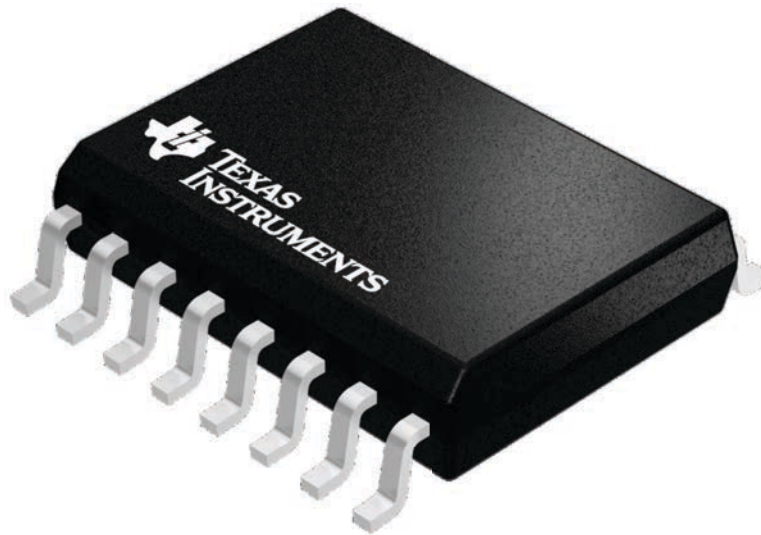

4224780/A

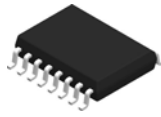

DW0016B

PACKAGE OUTLINE SOIC - 2.65 mm max height

SOIC

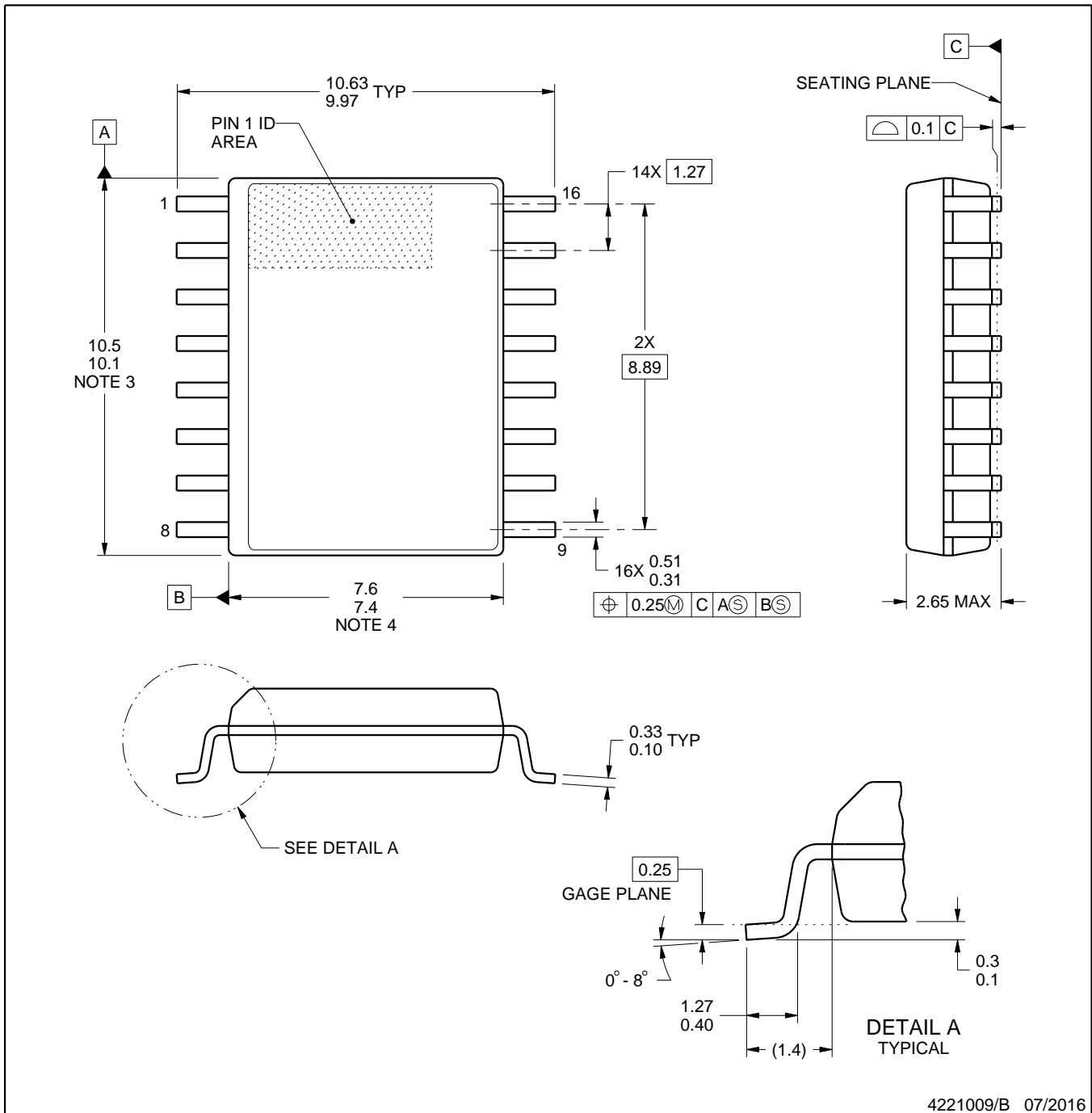

4221009/B 07/2016

NOTES:

1. All linear dimensions are in millimeters. Dimensions in parenthesis are for reference only. Dimensioning and tolerancing per ASME Y14.5M.
2. This drawing is subject to change without notice.
3. This dimension does not include mold flash, protrusions, or gate burrs. Mold flash, protrusions, or gate burrs shall not exceed 0.15 mm, per side.
4. This dimension does not include interlead flash. Interlead flash shall not exceed 0.25 mm, per side.
5. Reference JEDEC registration MS-013.

EXAMPLE BOARD LAYOUT

DW0016B

SOIC - 2.65 mm max height

SOIC

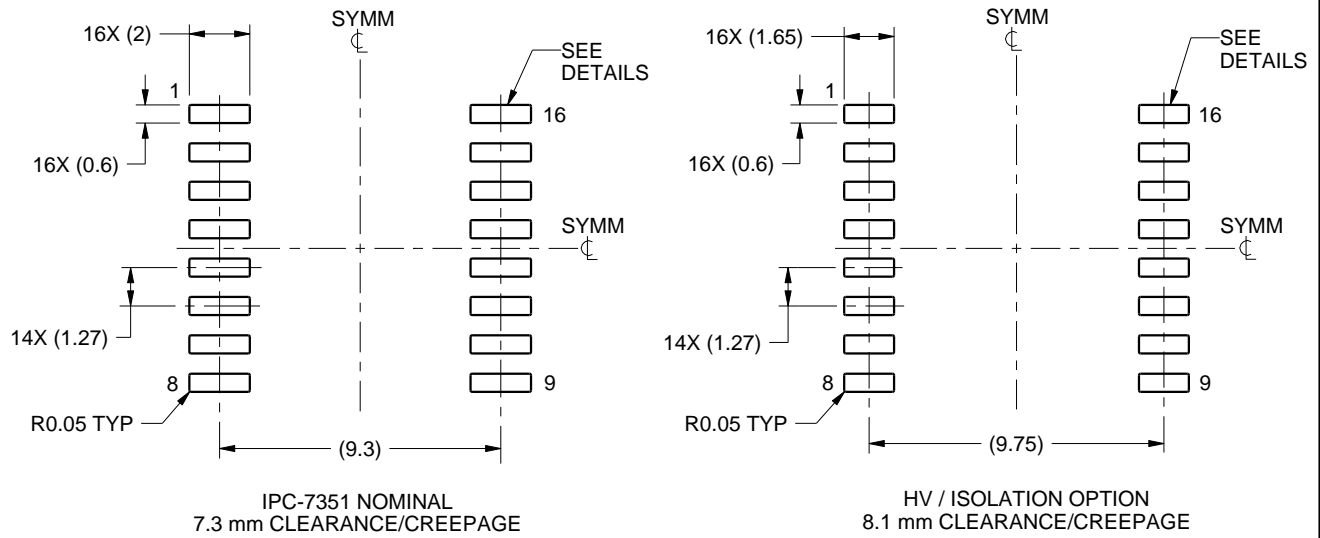

LAND PATTERN EXAMPLE
SCALE:4X

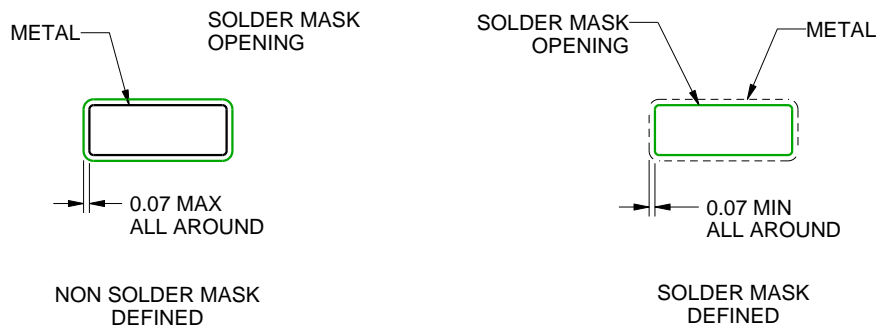

SOLDER MASK DETAILS

4221009/B 07/2016

NOTES: (continued)

- 6. Publication IPC-7351 may have alternate designs.
- 7. Solder mask tolerances between and around signal pads can vary based on board fabrication site.

EXAMPLE STENCIL DESIGN

DW0016B

SOIC - 2.65 mm max height

SOIC

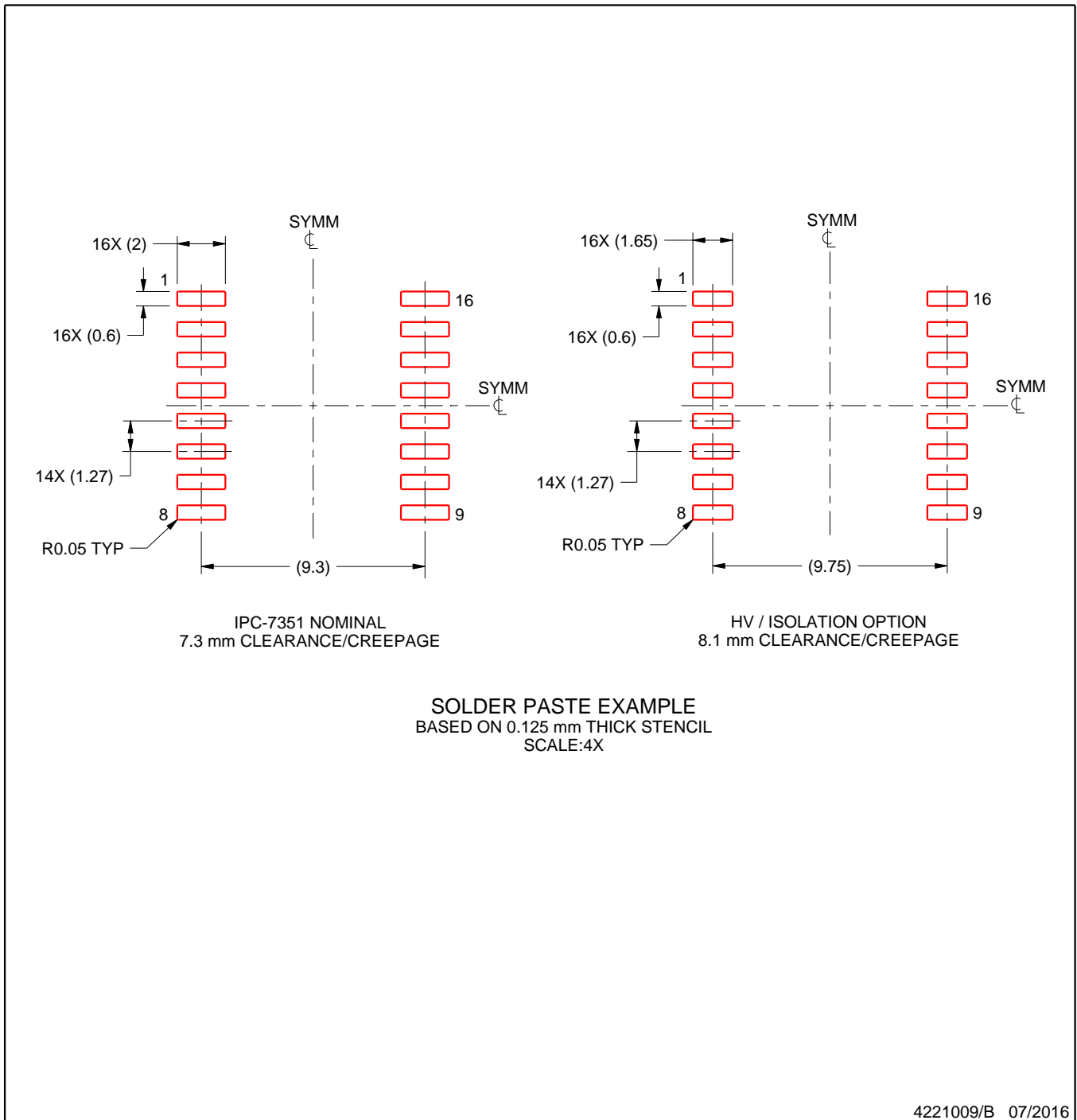

NOTES: (continued)

8. Laser cutting apertures with trapezoidal walls and rounded corners may offer better paste release. IPC-7525 may have alternate design recommendations.
9. Board assembly site may have different recommendations for stencil design.

GENERIC PACKAGE VIEW

DBQ 16

SSOP - 1.75 mm max height

SHRINK SMALL-OUTLINE PACKAGE

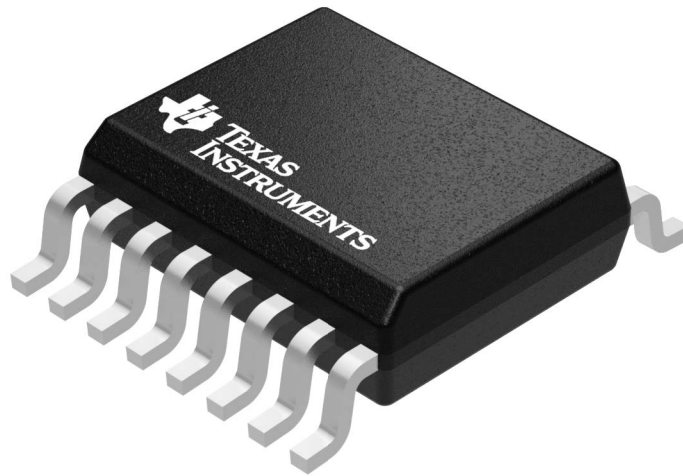

Images above are just a representation of the package family, actual package may vary.
Refer to the product data sheet for package details.

4073301-2/1

EXAMPLE BOARD LAYOUT

DBQ0016A

SSOP - 1.75 mm max height

SHRINK SMALL-OUTLINE PACKAGE

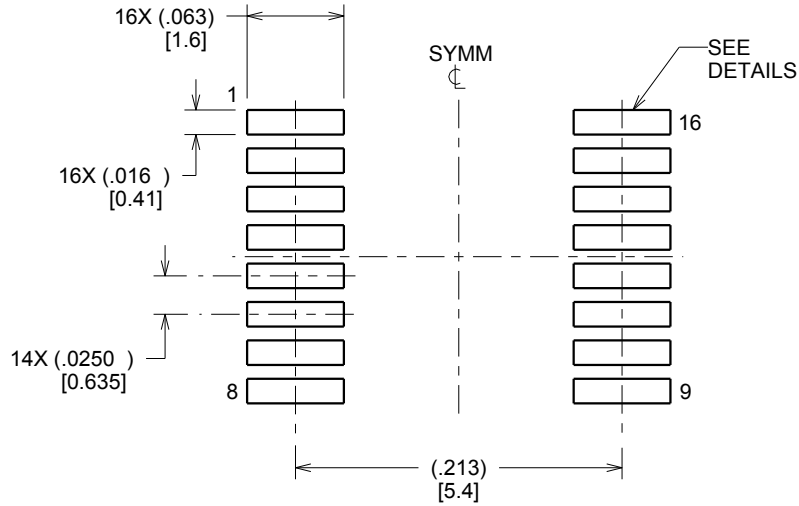

LAND PATTERN EXAMPLE
SCALE:8X

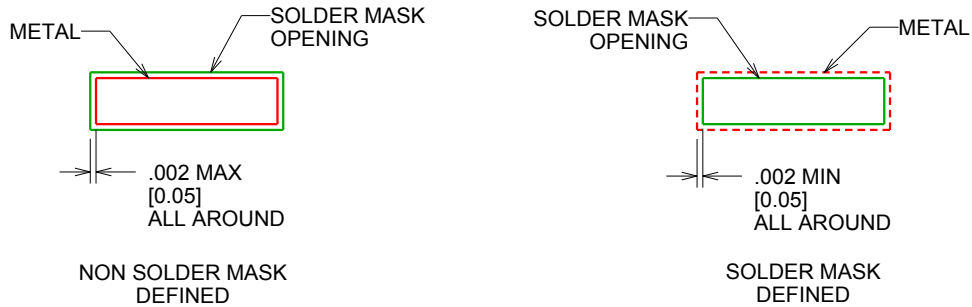

SOLDER MASK DETAILS

4214846/A 03/2014

NOTES: (continued)

- 6. Publication IPC-7351 may have alternate designs.
- 7. Solder mask tolerances between and around signal pads can vary based on board fabrication site.

EXAMPLE STENCIL DESIGN

DBQ0016A

SSOP - 1.75 mm max height

SHRINK SMALL-OUTLINE PACKAGE

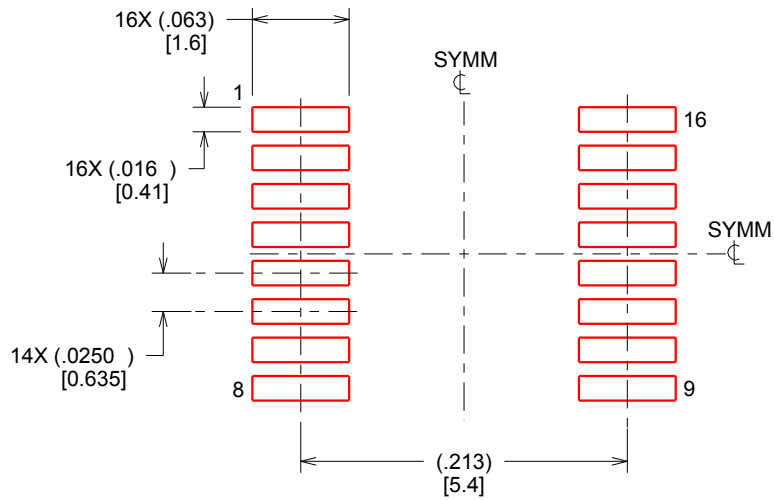

SOLDER PASTE EXAMPLE
BASED ON .005 INCH [0.127 MM] THICK STENCIL
SCALE:8X

4214846/A 03/2014

NOTES: (continued)

8. Laser cutting apertures with trapezoidal walls and rounded corners may offer better paste release. IPC-7525 may have alternate design recommendations.
9. Board assembly site may have different recommendations for stencil design.

IMPORTANT NOTICE AND DISCLAIMER

TI PROVIDES TECHNICAL AND RELIABILITY DATA (INCLUDING DATASHEETS), DESIGN RESOURCES (INCLUDING REFERENCE DESIGNS), APPLICATION OR OTHER DESIGN ADVICE, WEB TOOLS, SAFETY INFORMATION, AND OTHER RESOURCES "AS IS" AND WITH ALL FAULTS, AND DISCLAIMS ALL WARRANTIES, EXPRESS AND IMPLIED, INCLUDING WITHOUT LIMITATION ANY IMPLIED WARRANTIES OF MERCHANTABILITY, FITNESS FOR A PARTICULAR PURPOSE OR NON-INFRINGEMENT OF THIRD PARTY INTELLECTUAL PROPERTY RIGHTS.

These resources are intended for skilled developers designing with TI products. You are solely responsible for (1) selecting the appropriate TI products for your application, (2) designing, validating and testing your application, and (3) ensuring your application meets applicable standards, and any other safety, security, or other requirements. These resources are subject to change without notice. TI grants you permission to use these resources only for development of an application that uses the TI products described in the resource. Other reproduction and display of these resources is prohibited. No license is granted to any other TI intellectual property right or to any third party intellectual property right. TI disclaims responsibility for, and you will fully indemnify TI and its representatives against, any claims, damages, costs, losses, and liabilities arising out of your use of these resources.

TI's products are provided subject to TI's Terms of Sale (www.ti.com/legal/termsofsale.html) or other applicable terms available either on ti.com or provided in conjunction with such TI products. TI's provision of these resources does not expand or otherwise alter TI's applicable warranties or warranty disclaimers for TI products.

Mailing Address: Texas Instruments, Post Office Box 655303, Dallas, Texas 75265
Copyright © 2020, Texas Instruments Incorporated

Looking for pricing, stock, or lifecycle information?

Click below to explore more details on WIN SOURCE:

 [View ISO7731QDBQRQ1](#) on WIN SOURCE

 [Texas Instruments](#) Information

Optimize Your Supply Chain with WIN SOURCE Solutions

-  Global Sourcing Solution
-  Obsolete Management
-  Cost Control Management
-  Shortage Management
-  Alternative Solution
-  Excess Inventory Management