



**THE DATASHEET OF
1ED3491MC12MXUMA1**



EiceDRIVER™ 1ED34x1Mc12M Enhanced

Datasheet

Single-channel 5.7 kV (rms) isolated gate driver IC with adjustable DESAT and soft-off

Features

- 650 V, 1200 V, 1700 V, 2300 V IGBTs, SiC, and Si MOSFETs
- 40 V absolute maximum output supply voltage
- ± 3 A, ± 6 A, and ± 9 A typical sinking and sourcing peak output current
- Separate source and sink outputs for hard switching and with active Miller clamp/clamp driver
- Adjustment pins for parameter configuration from input side
- Precise V_{CEsat} detection (DESAT) with fault output and adjustable filter time and leading edge blanking time with resistor at *ADJB* pin
- Adjustable IGBT soft turn-off after desaturation detection with resistor at *ADJA* pin
- Operation at high ambient temperature up to 125 °C with over-temperature shut down at 160 °C (± 10 °C)
- Tight IC-to-IC propagation delay matching ($t_{PDD,max} = 30$ ns)
- Undervoltage lockout protection with hysteresis for input and output side with active shut-down
- High common-mode transient immunity CMTI = 200 kV/ μ s
- Small space-saving DSO-16 fine-pitch package with large creepage distance (>8 mm)
- Safety certification
 - UL 1577 recognized (File E311313) with $V_{ISO,test} = 6840$ V (rms) for 1 s, $V_{ISO} = 5700$ V (rms) for 60 s
 - VDE 0884-11 approval (Certificate no. 40053980) with $V_{IORM} = 1767$ V (peak, reinforced)
- Evaluation board available [EVAL-1ED3491MX12M](#)

Potential applications

- Industrial motor drives - compact, standard, premium, servo drives
- Solar inverters
- UPS systems
- Welding
- Commercial and agricultural vehicles (CAV)
- Commercial air-conditioning (CAC)
- High-voltage isolated DC-DC converters
- Isolated switch mode power supplies (SMPS)



PG-DSO-16

Product validation

Qualified for industrial applications according to the relevant tests of JEDEC47/20/22.

Device information

Device information

Product type	Output current	CLAMP type ¹⁾	Isolation class	Marking	OPN
1ED3431MC12M	3 A (typ)	CLAMP	reinforced	3431MC12	1ED3431MC12MXUMA1
1ED3461MC12M	6 A (typ)	CLAMPDRV	reinforced	3461MC12	1ED3461MC12MXUMA1
1ED3491MC12M	9 A (typ)	CLAMPDRV	reinforced	3491MC12	1ED3491MC12MXUMA1
1ED3431MU12M	3 A (typ)	CLAMP	UL 1577	3431MU12	1ED3431MU12MXUMA1
1ED3461MU12M	6 A (typ)	CLAMPDRV	UL 1577	3461MU12	1ED3461MU12MXUMA1
1ED3491MU12M	9 A (typ)	CLAMPDRV	UL 1577	3491MU12	1ED3491MU12MXUMA1

1) Please refer to [Chapter 4.5.4.1](#) for circuit connection to avoid damage to the gate driver IC

Description

The 1ED34x1Mc12M family (X3 Analog) consists of galvanically isolated single channel gate driver ICs in a small PG-DSO-16 package with a large creepage and clearance of 8 mm. The gate driver ICs provide a typical peak output current of 3 A, 6 A, and 9 A.

Adjustable control and protection functions are included to simplify the design of highly reliable systems. All parameter adjustments are done from the input side, including adjustable DESAT filter time, leading edge blanking time, and soft-off current level with only two resistors..

All logic I/O pins are supply voltage dependent 3.3 V or 5 V CMOS compatible and can be directly connected to a microcontroller.

The data transfer across the galvanic isolation is realized by the integrated coreless transformer technology.

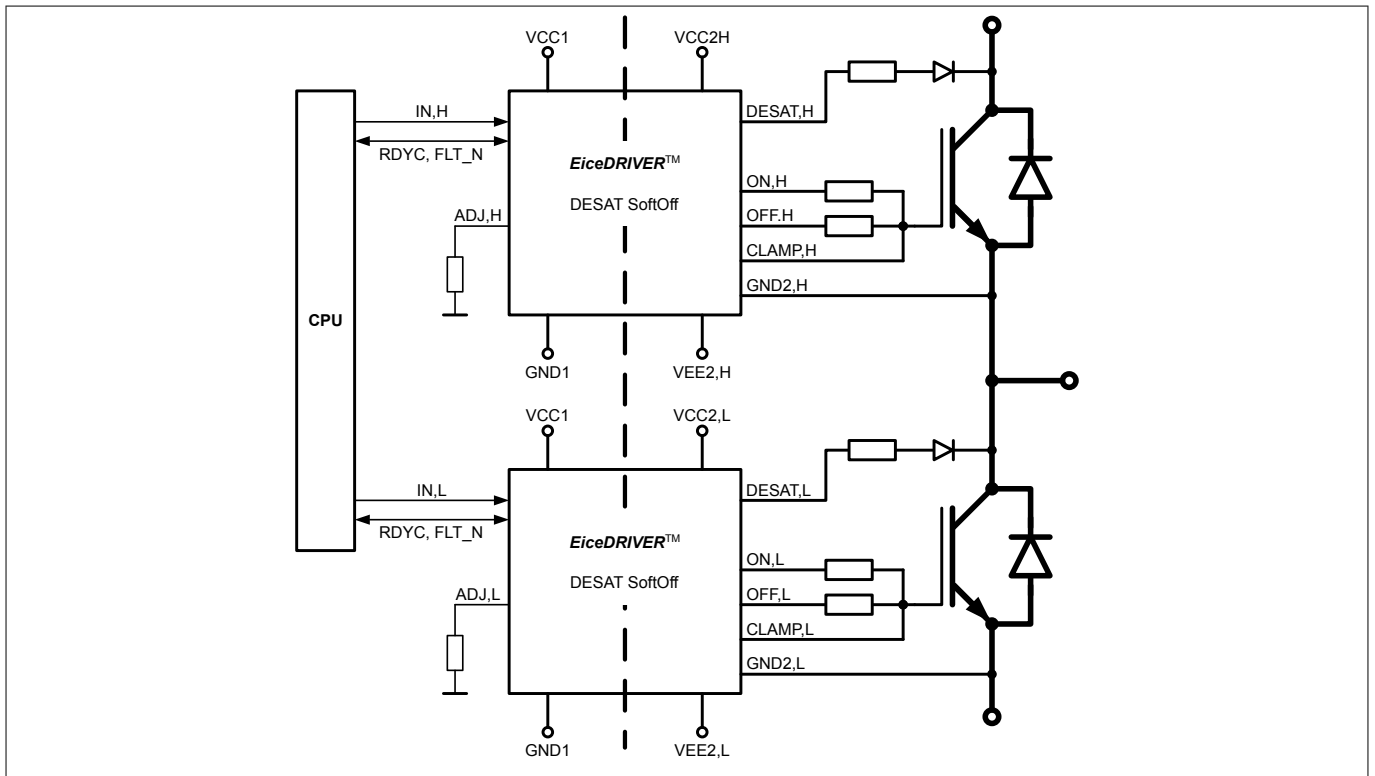

Figure 1 Typical application

Table of contents

	Table of contents	3
1	Block diagram	5
2	Related products	6
3	Pin configuration and functionality	7
3.1	Pin configuration	7
3.2	Pin functionality	9
4	Functional description	11
4.1	Start-up and fault clearing	11
4.2	Supply	12
4.2.1	Input side undervoltage lockout, <i>VCC1</i> UVLO	13
4.2.2	Output side under-voltage lockout, <i>VCC2</i> UVLO	13
4.3	Input side logic	15
4.3.1	IN non-inverting driver input	15
4.3.2	<i>RDYC</i> ready status output, fault-off and fault clear input	15
4.3.2.1	<i>RDYC</i> fault-off input	15
4.3.2.2	<i>RDYC</i> fault clear input	16
4.3.3	<i>FLT_N</i> status output and fault-off input	16
4.3.3.1	<i>FLT_N</i> fault-off input	16
4.4	Desaturation protection	18
4.4.1	DESAT behavior	18
4.4.2	DESAT filter and leading edge blanking time adjustment with <i>ADJB</i>	19
4.5	Gate driver output	21
4.5.1	Turn-on behavior	22
4.5.2	Turn-off and fault turn-off behavior	22
4.5.2.1	Hard switching turn-off	22
4.5.2.2	Soft turn-off	22
4.5.2.2.1	Soft-off current source adjustment with <i>ADJA</i>	23
4.5.3	Active shut-down	24
4.5.4	Active Miller clamp	24
4.5.4.1	CLAMP output types	24
4.5.5	Switch-off timeout until forced switch-off	26
4.6	Short circuit clamping	26
5	Electrical parameters	28
5.1	Absolute maximum ratings	28
5.2	Thermal parameters	29
5.3	Operating parameters	29
5.4	Electrical characteristics	31
5.4.1	Voltage supply	31

Table of contents

5.4.2	Logic input and output	32
5.4.3	Analog input	32
5.4.4	Gate driver	34
5.4.5	Active Miller clamp	35
5.4.6	Dynamic characteristics	36
5.4.7	Desaturation protection	37
5.4.8	Soft-off current source	39
5.4.9	Over-temperature protection	40
6	Insulation characteristics	41
6.1	Certified according to VDE 0884-11 reinforced insulation (Certificate no. 40053980)	41
6.2	Recognized under UL 1577 (File E311313)	42
7	Package information	43
8	Application notes	44
8.1	Reference layout for thermal data	44
8.2	Printed circuit board guidelines	44
	Revision history	44
	Disclaimer	45

1 Block diagram

1 Block diagram

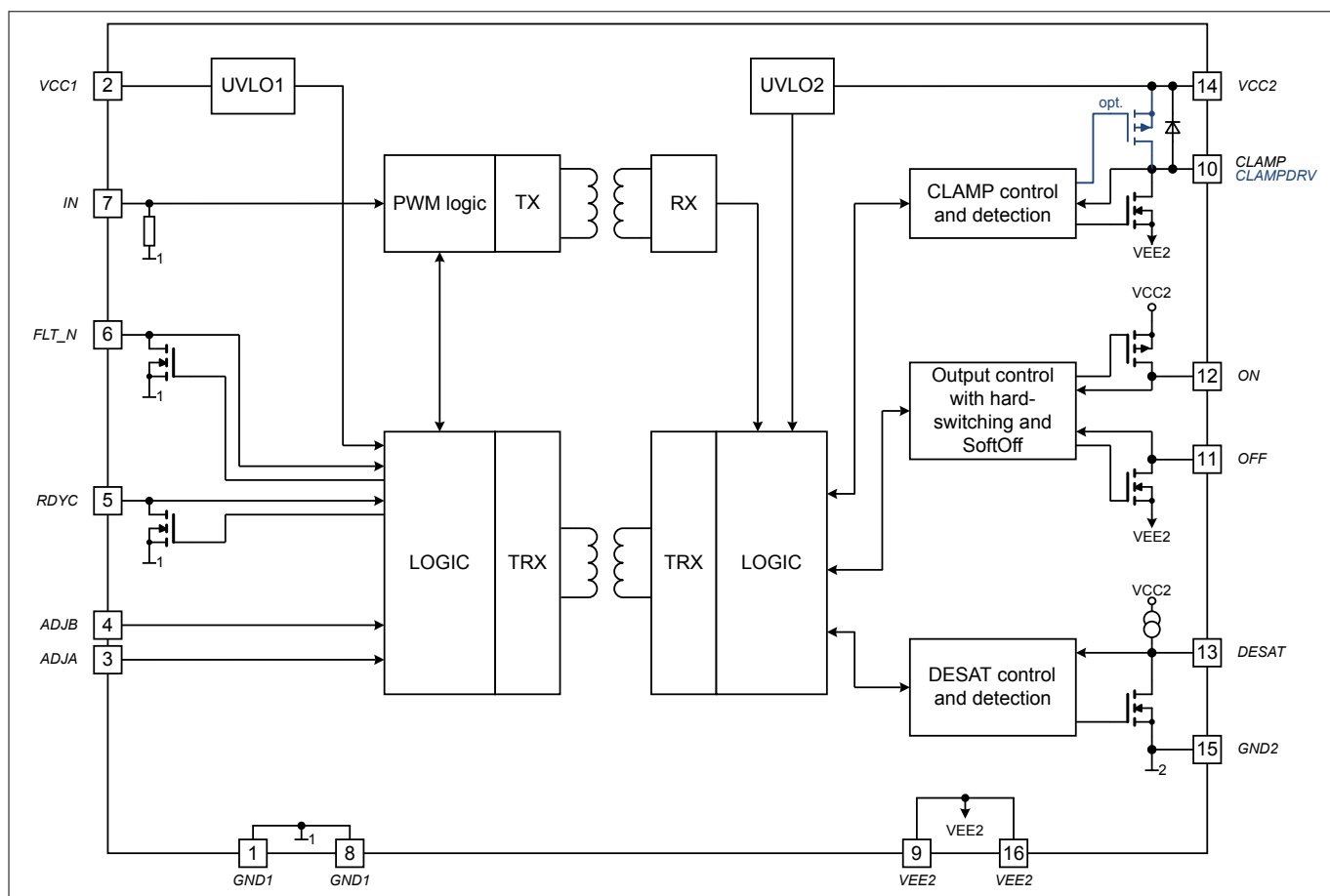

Figure 2 Block diagram

2 Related products

2 Related products

Note: Please consider the gate driver IC power dissipation and insulation requirements for the selected power switch and operating condition.

Product group	Product name	Description
TRENCHSTOP™ IGBT Discrete	IKQ75N120CS6	High Speed 1200 V, 75 A IGBT with anti-parallel diode in TO247-3
	IKW15N120BH6	High Speed 1200 V, 15 A IGBT with anti-parallel diode in TO247
	IHW40N120R5	Reverse conducting 1200 V, 40 A IH IGBT with integrated diode in TO247
CoolSiC™ SiC MOSFET Discrete	IMBF170R650M1	1700 V, 650 mΩ SiC MOSFET in TO263-7 package
	IMBG120R045M1H	1200 V, 45 mΩ SiC MOSFET in TO263-7 package
	IMZ120R350M1H	1200 V, 350 mΩ SiC MOSFET in TO247-4 package
CoolSiC™ SiC MOSFET Module	FS45MR12W1M1_B11	EasyPACK™ 1B 1200 V / 45 mΩ sixpack module
	FF23MR12W1M1_B11	EasyDUAL™ 1B 1200 V, 23 mΩ half-bridge module
	FF6MR12W2M1_B11	EasyDUAL™ 2B 1200 V, 6 mΩ half-bridge module
	F3L11MR12W2M1_B74	EasyPACK™ 2B 1200 V, 11 mΩ 3-Level module in Advanced NPC (ANPC) topology
	F4-23MR12W1M1_B11	EasyPACK™ 1B 1200 V, 23 mΩ fourpack module
TRENCHSTOP™ IGBT Modules	F4-100R17N3E4	EconoPACK™ 3 1700 V, 100 A fourpack IGBT module
	F4-200R17N3E4	EconoPACK™ 3 1700 V, 200 A fourpack IGBT module
	FS150R17N3E4	EconoPACK™ 3 1700 V, 150 A sixpack IGBT module
	FF650R17IE4	PrimePACK™ 3 1700 V, 650 A half-bridge dual IGBT module
	FF1000R17IE4	PrimePACK™ 3 1700 V, 1000 A half-bridge dual IGBT module
	FF1200R17IP5	PrimePACK™ 3+ 1700 V, 1200 A dual IGBT module
	FF1500R17IP5	PrimePACK™ 3+ 1700 V, 1500 A dual IGBT module
	FF1500R17IP5R	PrimePACK™ 3 1700 V, 1500 A dual IGBT module
	FF1800R17IP5	PrimePACK™ 3+ 1700 V, 1800 A dual IGBT module
	FP10R12W1T7_B11	EasyPIM™ 1B 1200 V, 10 A three phase input rectifier PIM IGBT module
	FS100R12W2T7_B11	EasyPACK™ 2B 1200 V, 100 A sixpack IGBT module
	FP150R12KT4_B11	EconoPIM™ 3 1200V three-phase PIM IGBT module
	FS200R12KT4R_B11	EconoPACK™ 3 1200 V, 200 A sixpack IGBT module

3 Pin configuration and functionality

3 Pin configuration and functionality

The pin assignment at the gate driver IC generally differentiates between the input side and the output side.

Table 1 General pin assignment

Pins	Designation
1 to 8	input side, input logic signal side, or low voltage side
9 to 16	output side, driver power side, or high voltage side

For simplicity reasons the driver is described as an IGBT driver. For use with MOSFETs and other power switches simply replace any mentioning of collector and emitter with their corresponding pin names.

3.1 Pin configuration

Table 2 Pin configuration table abbreviations

Abbreviation	Description
Pin type	
PWR	Power supply and gate current output pins
I/O	Digital input and output pin
I	Digital input pin
GND	Ground reference pin
AI	Analog input pin
Buffer type	
OD	Open drain output
CMOS	CMOS compatible input threshold levels
PP	Push/pull output buffer
special	Special output/input function, see individual description
Pull device	
PD	Pull-down resistor
CS	Current source

Table 3 Pin configuration

Pin no.	Pin name	Pin type	Buffer type	Pull device	Function
1	<i>GND1</i>	GND	–	–	Ground input side
2	<i>VCC1</i>	PWR	–	–	Positive power supply input side
3	<i>ADJA</i>	AI	special	CS	Parameter adjust set A
4	<i>ADJB</i>	AI	special	CS	Parameter adjust set B
5	<i>RDYC</i>	I/O	OD, CMOS	–	Combined ready output, high active and fault clear input and soft-off input, low active
6	<i>FLT_N</i>	I/O	OD, CMOS	–	Fault output, low active and soft- off input, low active
7	<i>IN</i>	I	CMOS	PD, 40 kΩ	Non inverted driver input

(table continues...)

3 Pin configuration and functionality

Table 3 (continued) Pin configuration

Pin no.	Pin name	Pin type	Buffer type	Pull device	Function
8	GND1	GND	-	-	Ground input side
9	VEE2	GND	-	-	Negative power supply output side
10	CLAMP	PWR	OD	-	Active Miller clamping, open drain to VEE2 (1ED3431M only)
10	CLAMPDRV	PWR	PP	-	Active miller clamping, clamp driver for external MOSFET (1ED3461M, 1ED3491M)
11	OFF	PWR, AI	OD	-	Driver sink output
12	ON	PWR, AI	OD	-	Driver source output
13	DESAT	AI	special	CS, 500 μ A	Enhanced desaturation protection
14	VCC2	PWR	-	-	Positive power supply output side
15	GND2	AI	-	-	Signal ground output side
16	VEE2	GND	-	-	Negative power supply output side

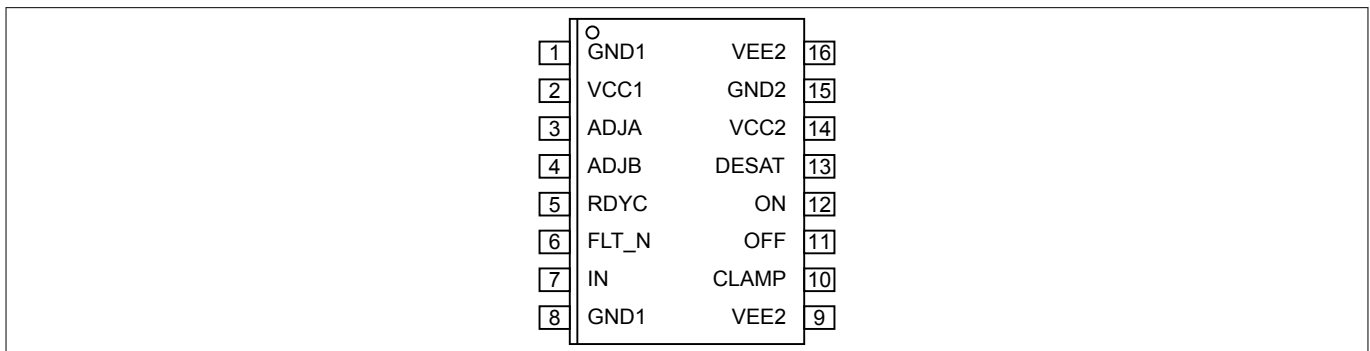

Figure 3 PG-DSO-16 (top view) with CLAMP

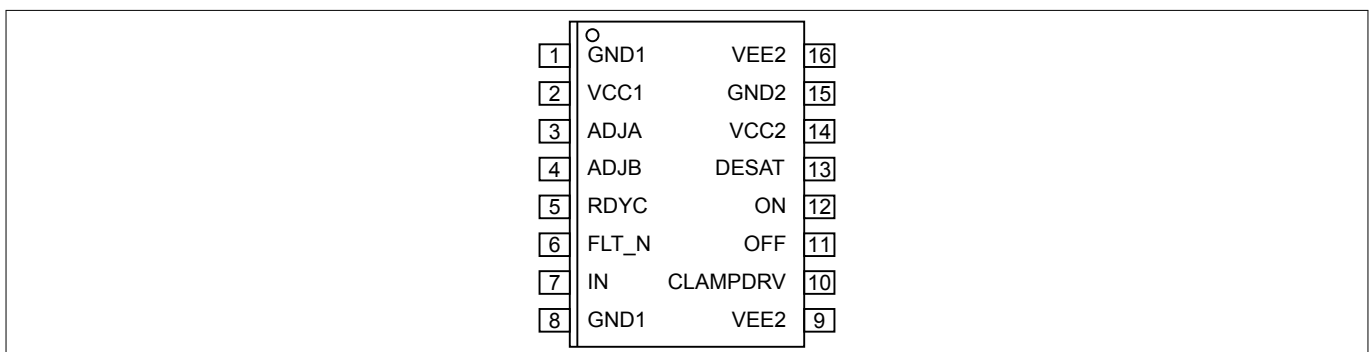

Figure 4 PG-DSO-16 (top view) with CLAMPDRV

3 Pin configuration and functionality

3.2 Pin functionality

GND1

Reference ground of the input side. Connect direct to input signal ground.

VCC1

Positive power supply terminal of the input side, connect to 5 V or 3.3 V for proper operation. Place a decoupling capacitor close to this pin and *GND1*.

***ADJA* and *ADJB* parameter adjust input for set A or B**

The pins *ADJA* and *ADJB* are used to adjust two sets of independent parameters of output functions.

Connect a resistor between 1.33 k Ω and 28.0 k Ω to *GND1* to adjust each parameter. All valid resistor values belong to the E96-series with 1% tolerance.

Connecting *ADJA* to *GND1* uses a default value for soft switch-off. Connecting it to *VCC1* is disabling the gate driver IC.

Connecting *ADJB* to *GND1* is disabling the gate driver IC. Connecting it to *VCC1* is setting the function to minimum values.

***RDYC* ready status output, fault-off input and fault-clear input**

Open-drain output reports the correct operation of the device, ready output is high active. Fault-clear input and fault-off input clears a gate driver fault or switch the gate driver output to off with fault-off function, input is low active. Connect to a microcontroller with 5 V or 3.3 V I/O with an external pull-up resistor to *VCC1*. A typical value for this resistor is 2.2 k Ω . The *RDCY* signal is referenced to *GND1*.

***FLT_N* fault output and fault-off input**

Open-drain output reports the failures related to operating of the inverter system to the microcontroller, fault output is active low. Fault-off input switch the gate driver output to off with fault-off function, input is low active. Connect to a microcontroller with 5 V or 3.3 V I/O with an external pull-up resistor to *VCC1*. A typical value for this resistor is 2.2 k Ω . The *FLT_N* signal is referenced to *GND1*.

***IN* non inverting gate driver input**

IN input controls the output of the gate driver IC, the IGBT is turned on if *IN* is set to high. Connect to a PWM output of the microcontroller with 5 V or 3.3 V IO. An internal pull-down resistor ensures IGBT off-state if not connected. A minimum pulse width of typical 103 ns is defined to make the gate driver IC robust against glitches at *IN*.

VEE2

Negative power supply terminal of the output side. Connect to a voltage of 0 V to -25 V referenced to *GND2* for proper operation. Place a decoupling capacitor close to the following pins:

- *VCC2* and *VEE2*
- *GND2* and *VEE2*

If no negative supply voltage is used, all *VEE2* pins have to be connected to *GND2*.

***CLAMP* Miller clamp output, *CLAMPDRV* Miller clamp pre-driver output**

CLAMP: High-current clamp output to hold the gate voltage low during collector-emitter-voltage rise. Connect directly to the gate of the IGBT.

CLAMPDRV: Clamp pre-driver output for the use of an external clamp switch. Connect directly to the gate of a n-channel MOSFET.

3 Pin configuration and functionality

OFF driver output

High-current driver sink output to discharge the gate of the external IGBT. The gate driver IC also sinks the Soft-off current at this pin. Connect to the gate of the IGBT via a chosen turn-off gate resistor.

ON driver output

High-current driver source output to charge the gate of the external IGBT and turn it on and sense input for the CLAMP function. Connect to the gate of the IGBT via a chosen turn-on gate resistor.

DESAT enhanced desaturation detection input

Desaturation detection input to monitor the IGBT collector-emitter voltage (V_{CE}) to detect desaturation caused by short circuit events. Connect to the collector of the driven IGBT via a series connection of a protection resistor and a high-voltage diode. The *DESAT* signal is referenced to *GND2*.

VCC2

Positive power supply terminal of the output side. Connect to sufficient supply voltage referenced to *GND2* for proper operation. Place a decoupling capacitor close to the following pins:

- *VCC2* and *VEE2*
- *VCC2* and *GND2*

GND2 reference ground

Reference ground of the output side. Connect to common voltage of a bipolar supply and the emitter of the IGBT. Place a decoupling capacitor close to the following pins:

- *VCC2* and *GND2*
- *GND2* and *VEE2*

4 Functional description

4 Functional description

The 1ED34x1Mc12M family (X3 Analog) consists of galvanically isolated single channel gate driver ICs with adjustable feature parametrization by two simple resistors. All adjustments can be done from the low voltage input side.

To start-up the gate driver IC for normal operation both input and output sides of the gate driver IC need to be powered.

The 1ED34x1Mc12M family (X3 Analog) is designed to support various supply configurations on the input and output side. On the output side unipolar and bipolar supply is possible.

The output stage is realized as rail-to-rail. There the gate driver voltage follows the supply voltage without an additional voltage drop. In addition it provides an easy clamping of the gate voltage during short circuit of an external IGBT.

The *RDYC* status output reports correct operation of the gate driver IC like sufficient voltage supply. The *FLT_N* status output reports failures in the application like desaturation detection.

To ensure safe operation the gate driver IC is equipped with an input and output side under-voltage lockout circuit. The UVLO levels are optimized for IGBTs.

The desaturation detection circuit protects the external IGBT from destruction at a short circuit. The gate driver IC reacts on a DESAT fault by turning off the IGBT with the adjustable soft-off method.

The soft turn-off function is used to switch-off the external IGBT in overcurrent conditions in a soft-controlled manner to protect the IGBT against collector emitter over-voltages.

An active Miller clamp function protects the IGBT from parasitic turn-on in fast switching applications.

4.1 Start-up and fault clearing

For normal operation both input and output sides of the gate driver IC need to be powered. A low level at the *FLT_N* pin always indicates a fault condition. In this case the IC starts internal mechanisms for fault clearing.

Input side start-up

1. Voltage at *VCC1* reaches the input UVLO threshold: input side of gate driver IC starts operating
2. *FLT_N* follows input supply voltage
3. Records resistor programmable function from *ADJA* and *ADJB*
4. Waits until output side is powered
5. Initiates internal start-up: Transfers configured values to output side
6. Performs internal self-test

The start-up delay takes approx. 200 μ s and is part of the complete start-up time t_{START1} .

Output side start-up

1. Voltage at *VCC2* reaches the output UVLO threshold: output side of gate driver IC starts operating
2. Activates OFF gate driver output: connected gate stays discharged
3. Waits until input side is powered
4. Initiates internal start-up: Receives configured values from input side
5. Performs internal self-test

The start-up delay takes approx. 200 μ s and is part of the complete start-up time t_{START2} .

The gate driver IC releases *RDYC* to high to signal a successful start-up and its readiness to operate. The gate driver IC will follow the status of the *IN* signal.

Clearing a fault with *RDYC* to low cycle

1. Set *IN* to low
2. Set *RDYC* to low for a duration longer than the fault clear time t_{CLRMIN}

4 Functional description

3. Release *RDYC* to high
 - a. If the source of the fault is no longer present, *FLT_N* is released to high
 - b. If another fault source is active, *FLT_N* stays low and the cycle needs to be repeated
4. Continue PWM operation

4.2 Supply

The 1ED34x1Mc12M family (X3 Analog) is designed to support various supply configurations. The input side can be used with a 3.3 V or 5 V supply.

The output side requires either an unipolar supply ($VEE2 = GND2$) or a bipolar supply.

- Individual supply voltages between $VCC2$ and $GND2$ or $GND2$ and $VEE2$ shall not exceed 25 V.
- The total supply voltage between $VCC2$ and $VEE2$ shall not exceed 35 V.

To ensure safe operation of the gate driver IC, it is equipped with an input and output side undervoltage lockout circuit.

Unipolar supply

In unipolar supply configuration the gate driver IC is typically supplied with a positive voltage of 15 V at $VCC2$. $GND2$ and $VEE2$ are connected together and this common potential is connected to the IGBT emitter.

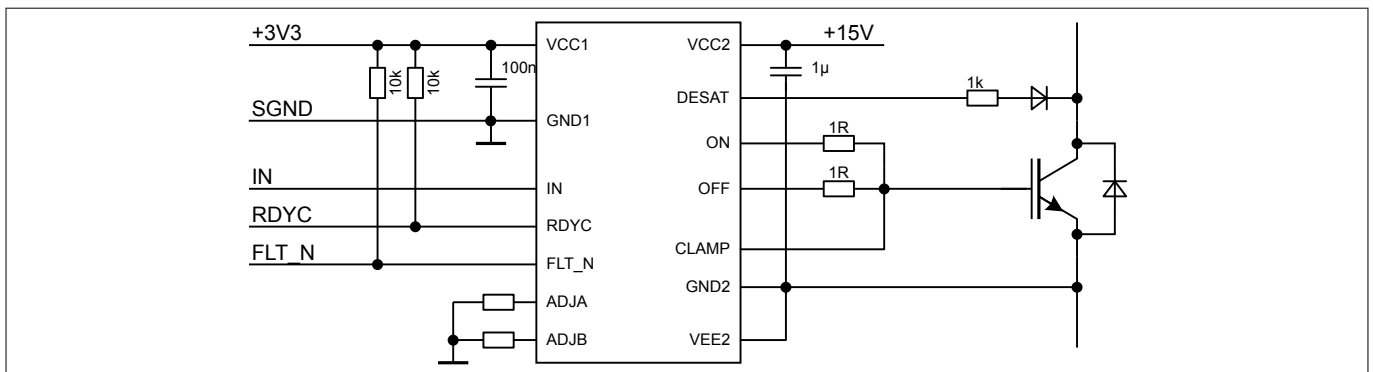

Figure 5 Application example with unipolar supply (1ED3431M)

Bipolar supply

For bipolar supply the gate driver IC is typically supplied with a positive voltage of 15 V at $VCC2$ and a negative voltage of -8 V or -15 V at $VEE2$ relative to $GND2$.

Between $VCC2$ and $VEE2$ the maximum potential difference is 35 V.

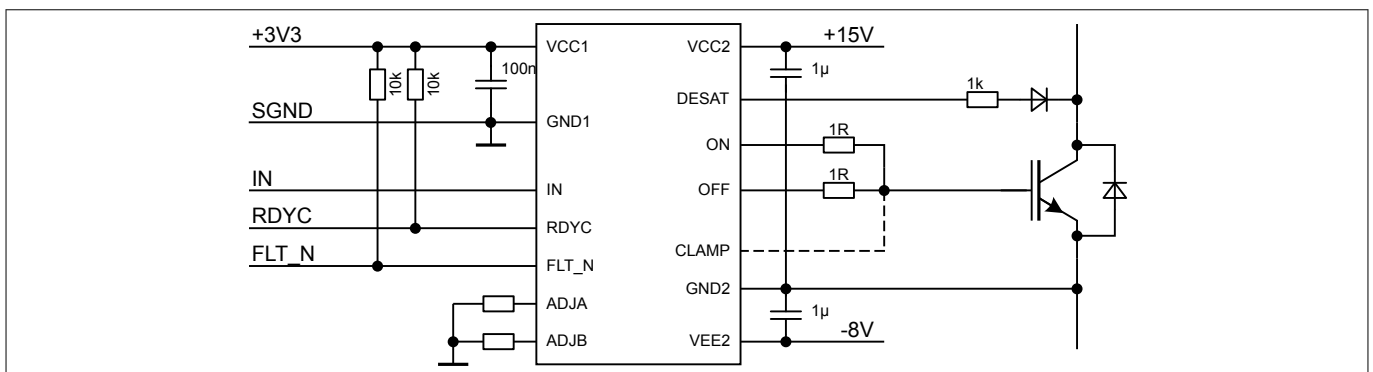

Figure 6 Application example with bipolar supply (1ED3431M)

Negative supply prevents a parasitic turn-on due to the additional voltage margin to the gate turn-on threshold.

4 Functional description

VEE2 over GND2 supply connection check

The gate driver IC has a built-in connection check for *VEE2*. A loss of *VEE2* connection will be detected and signaled via *RDYC*.

4.2.1 Input side undervoltage lockout, VCC1 UVLO

To ensure correct operation of the input side and safe operation of the application the gate driver IC is equipped with an input supply undervoltage lockout for *VCC1*.

UVLO behavior during start-up:

1. The voltage at the supply terminal *VCC1* reaches the V_{UVLO1H} threshold
2. The gate driver IC reads the *ADJA* and *ADJB* resistor values and transfers the configuration to the output side
3. The IC releases the *RDYC* output to **high** and is ready to operate.

The start-up delay takes approx. 200 μ s and is part of the complete start-up time t_{START1} .

UVLO behavior during shut-down:

- If the supply voltage V_{VCC1} of the input side drops below V_{UVLO1L} the *RDYC* signal is switched to **low** and the output will be switched off.

The fault signal *FLT_N* follows the input supply voltage.

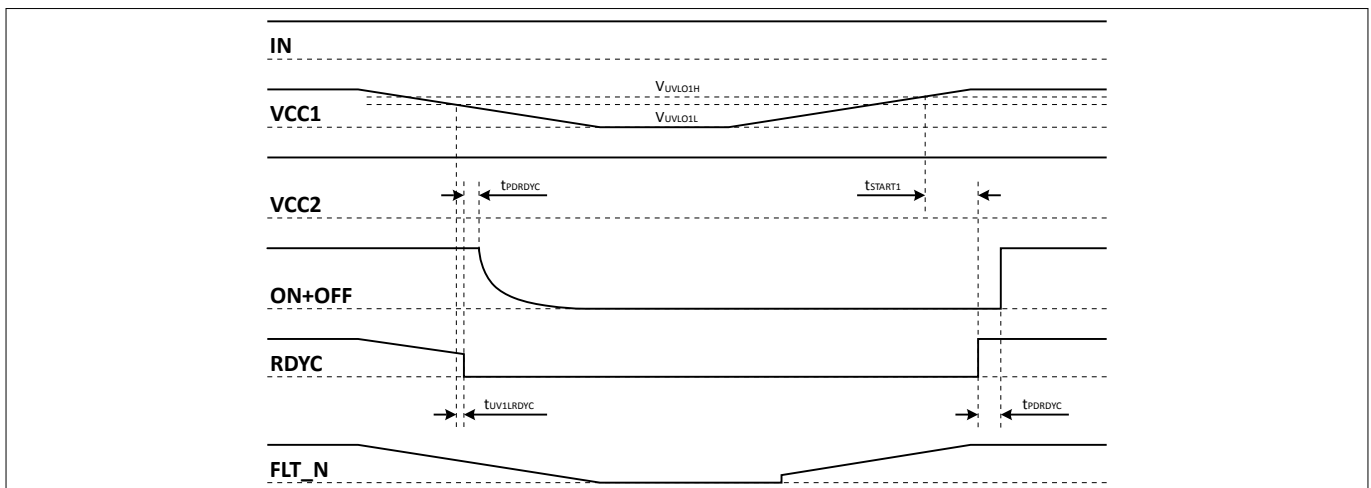

Figure 7 UVLO VCC1 behavior

4.2.2 Output side under-voltage lockout, VCC2 UVLO

To ensure correct operation of the output side and safe operation of the IGBT in the application, the gate driver IC is equipped with an output supply undervoltage lockout for *VCC2* versus *GND2*.

UVLO behavior during start-up:

- If the voltage at the supply terminal *VCC2* reaches the V_{UVLO2H} threshold the *RDYC* output is released to **high** and the gate driver IC is ready to operate.

The start-up delay takes approx. 200 μ s and is part of the complete start-up time t_{START2} .

UVLO behavior during shut-down:

- If the supply voltage V_{VCC2} of the output side drops below V_{UVLO2L} the *RDYC* signal is switched to **low** and the output will be switched off.

4 Functional description

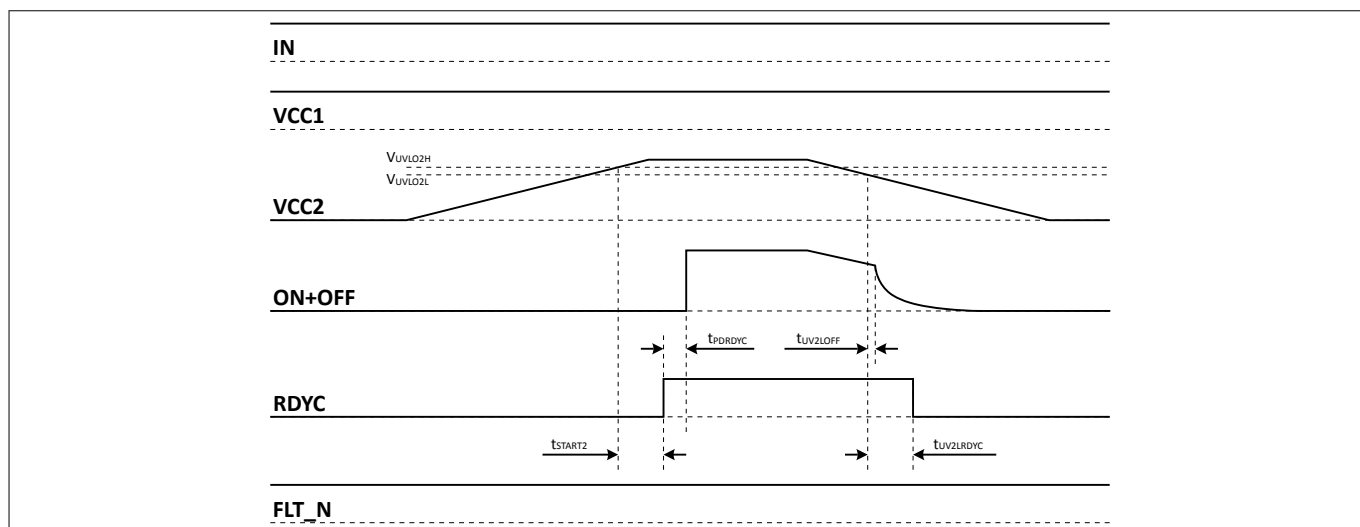

Figure 8 UVLO VCC2 behavior

Any V_{UVLO2L} event will lead to a fault-off and a *RDYC* low level. Depending of the level of the voltage drop, the gate driver IC either stays in a not ready state and waits for the supply voltage to recover, or it will fully reset the gate driver IC. Both variants differ in the necessary delay of *RDYC* release after the supply voltage has recovered. After a reset, the gate driver IC needs to fully restart until it becomes ready again.

4 Functional description

4.3 Input side logic

The input threshold levels are always CMOS compliant. The threshold levels are 30% of $VCC1$ for low level and 70% of $VCC1$ for high level.

The 1ED34x1Mc12M family (X3 Analog) has three input pins (IN , $ADJA$, $ADJB$) and two I/O pins ($RDYC$, FLT_N) at the input side.

4.3.1 IN non-inverting driver input

The input pin has a positive logic. To turn on the associated IGBT apply a logic high signal at the IN pin. A minimum pulse width of typical 103 ns is defined to make the IC robust against glitches at IN .

4.3.2 RDYC ready status output, fault-off and fault clear input

The $RDYC$ pin is a logic input and open drain output and has three different functions:

- $RDYC$ as ready status output of all ready sources
- $RDYC$ as fault-off input
- $RDYC$ as fault clear input

In a typical application the $RDYC$ pins of all gate driver ICs in the inverter are connected together and form a single wire $RDYC$ signal.

An external pull-up resistor is required to ensure $RDYC$ status output during operation.

Ready sources

- the input side is properly supplied, $VCC1$ supply above $UVLO1$ threshold
- the output side is properly supplied with a positive voltage, $VCC2$ supply above $UVLO2$ threshold
- no $VEE2$ over $GND2$ failure
- Internal signal transmission is operating nominal
- the ON pin monitoring of the gate driver is below $VEE2 + 2V$, IGBT has to be off at start-up

4.3.2.1 RDYC fault-off input

Pulling $RDYC$ to low disables the operation of the gate driver IC. The gate driver IC ignores IN signals as long as the $RDYC$ pin stays low and the IC uses its fault-off function to switch-off the IGBT.

The defined minimum pulse width makes the IC robust against glitches at $RDYC$. The gate driver ignores pulses with a shorter duration.

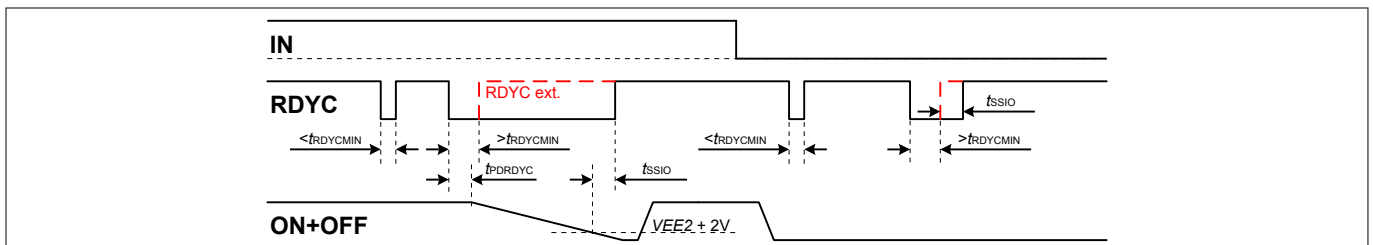

Figure 9 RDYC short pulse behavior of external manipulation of the RDYC pin

After an external $RDYC$ low signal the IC is actively pulling $RDYC$ to low until the voltage at ON pin falls below the $VEE2+2V$ threshold.

The $RDYC$ fault-off input is active low.

4 Functional description

4.3.2.2 RDYC fault clear input

Setting *RDYC* to low for longer than the fault clear time t_{CLRMIN} will reset the stored fault signal at pin *FLT_N* with the rising edge of *RDYC*. Additionally the following conditions have to be met as well:

- PWM *IN* pin level needs to be low,
- voltage at *ON* pin has dropped below the $VEE2+2V$ threshold, and
- triggering fault condition is no longer present.

The typical fault clear time t_{CLRMIN} is 1.0 μ s.

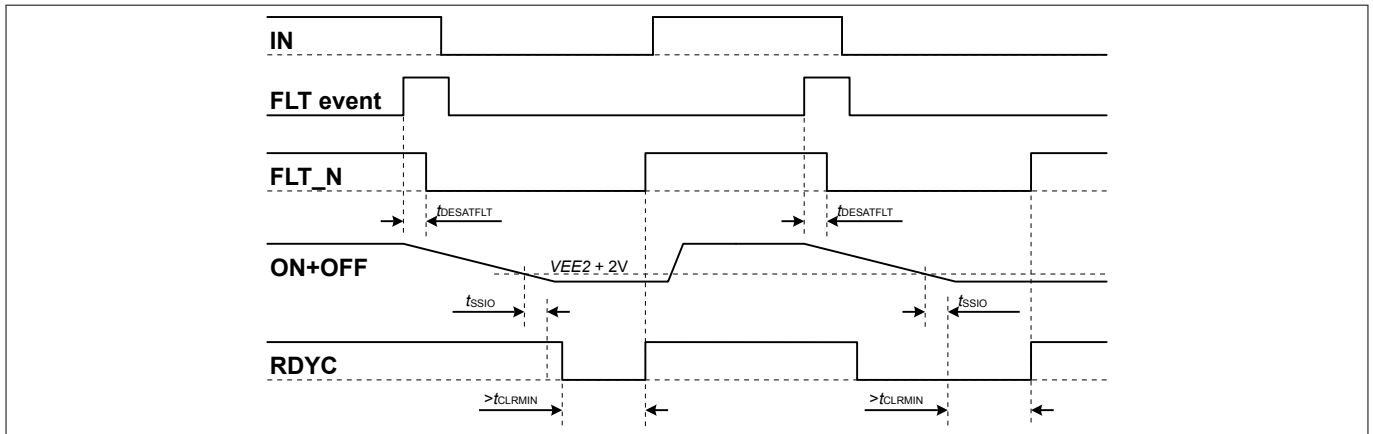

Figure 10 RDYC fault clear timing

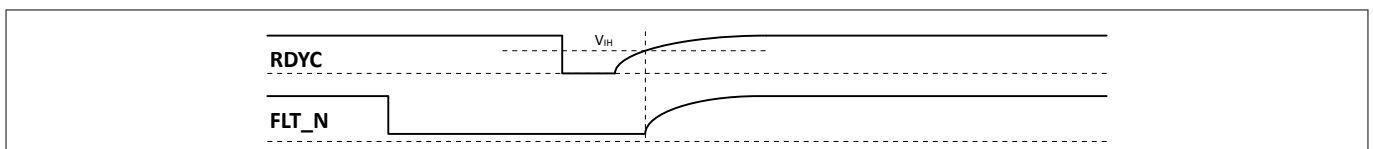

Figure 11 RDYC fault clear rising edge to FLT_N

4.3.3 FLT_N status output and fault-off input

The *FLT_N* pin is a logic input and open drain output and has two different functions:

- *FLT_N* as fault-status output for fault sources
- *FLT_N* as fault-off input

In a typical application the *FLT_N* pins of all gate driver ICs in the inverter are connected together and form a single wire *FLT_N* signal.

An external pull-up-resistor is required to ensure *FLT_N* status output during operation.

Fault sources

The following fault sources can trigger a *FLT_N* pin to low and initiate a fault turn-off:

- desaturation detection of IGBT
- gate driver over temperature protection

4.3.3.1 FLT_N fault-off input

Pulling *FLT_N* to low disables the operation of the gate driver IC. The gate driver IC ignores *IN* signals as long as the *FLT_N* pin stays low and the IC uses its fault-off function to switch-off the IGBT.

The defined minimum pulse width makes the gate driver IC robust against glitches at *FLT_N*.

After a low at the *FLT_N* pin either internally or externally applied, the fault event is latched until cleared.

4 Functional description

The *FLT_N* fault-off input is active low.

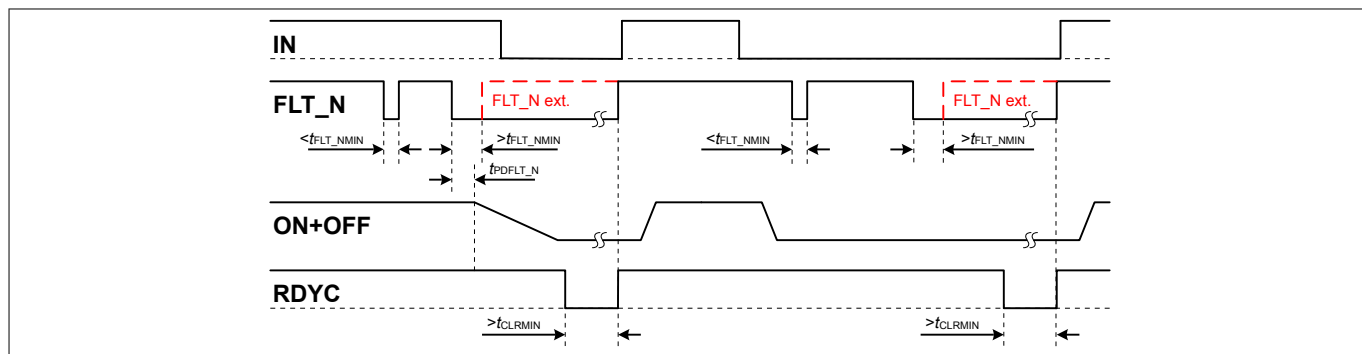

Figure 12 *FLT_N* short pulse behavior of external manipulation of the *FLT_N* pin cleared by *RDYC*

4 Functional description

4.4 Desaturation protection

The desaturation detection circuit protects the external IGBT from destruction at a short circuit. The desaturation protection follows the given sequence:

1. Voltage at *DESAT* pin reaches *DESAT* threshold level, for a period of time exceeding the filter time
2. Gate driver IC output switches the external IGBT off, using the soft-off method
3. Gate driver IC switches *FLT_N* pin to low to indicate the fault to a connected microcontroller
4. Short circuit situation is resolved
 - after the voltage at the *ON* pin has dropped below the $VEE2+2\text{ V}$ threshold,
 - no other fault condition is present,
 - the input has been turned off and
 - the fault has been cleared using the RDYC low cycle method

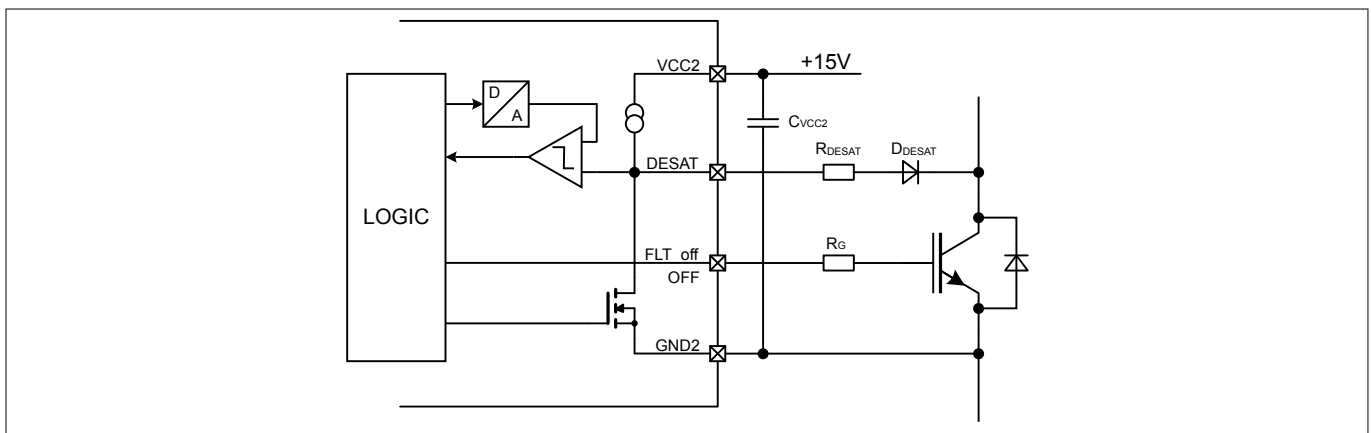

Figure 13 DESAT circuit (only relevant pins shown)

The 1ED34x1Mc12M family (X3 Analog) has a fixed *DESAT* threshold level of typical 9.18 V. If lower threshold levels are required, the *DESAT* resistor can be increased. Larger *DESAT* resistor values lead to lower *DESAT* threshold voltages. The threshold voltage reduction is equal to the *DESAT* current multiplied by the *DESAT* resistance.

The high-precision internal current source results in a minimum impact on the *DESAT* detection variation.

4.4.1 DESAT behavior

The *DESAT* function offers a leading edge blanking time and filters to optimize the *DESAT* detection for application usage.

The leading edge blanking inhibits threshold detection during an IGBT turn on phase. The typical IGBT turn on behavior starts with charging of the gate, commutation of the application load current and finally V_{CE} voltage decrease to V_{CEsat} voltage levels. To prevent the gate driver IC from detecting a false *DESAT* event, leading edge blanking pauses the *DESAT* circuit until the time $t_{DESATleb}$ has elapsed.

Following the leading edge blanking time, the gate driver IC forces the *DESAT* current into the external *DESAT* circuit. The current typically flows through a protection resistor, a fast high voltage diode and the collector-emitter path of the IGBT. The resulting voltage at the *DESAT* pin is the sum of the voltage drop across this path.

During a short circuit condition, the V_{CE} voltage increases, resulting in a reverse polarity condition of the *DESAT* diode. The remaining *DESAT* current also increases the voltage level at the *DESAT* pin and triggers the *DESAT* threshold. If the pin voltage level stays above the threshold for the duration of the *DESAT* filter time $t_{DESATfilter}$, the gate driver IC registers the *DESAT* event and acts accordingly.

4 Functional description

The internal processing time after DESAT threshold crossing, filtering and beginning of fault-off is defined as $t_{DESATOUT}$. The duration of the gate discharge during fault-off is defined as $t_{FLTOFFtot}$ and is depending on the soft-off function and the gate load.

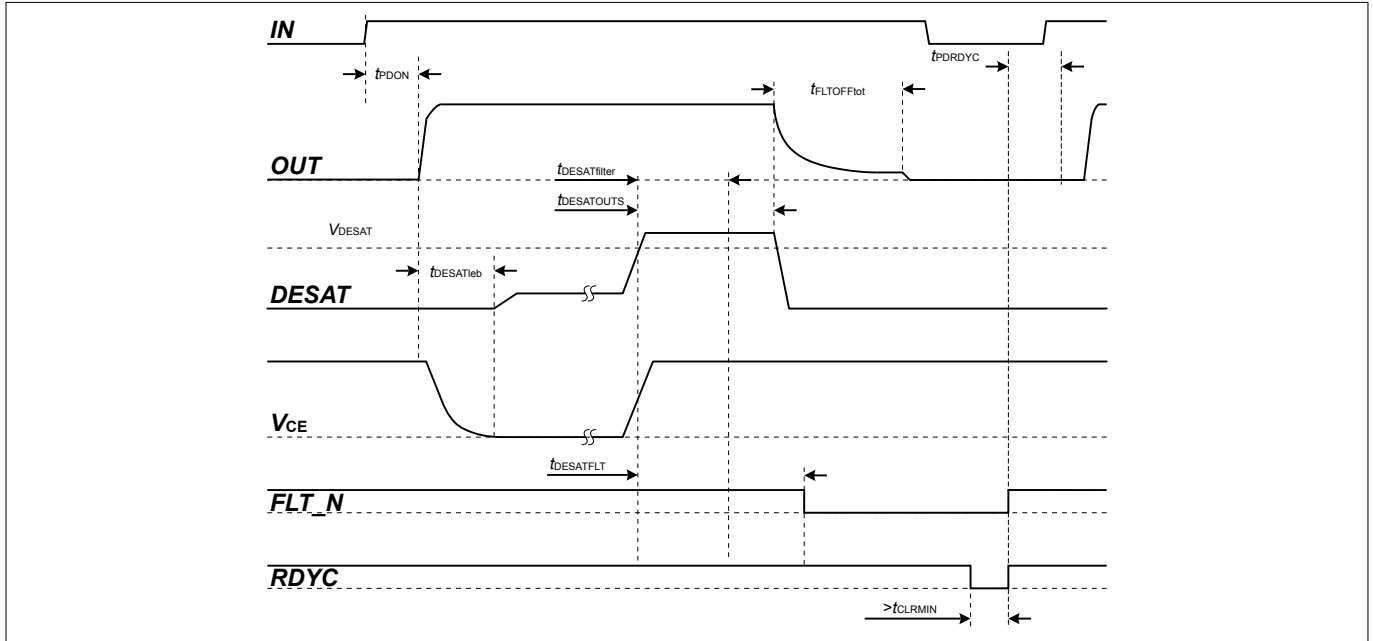

Figure 14 DESAT timing with leading edge blanking, filter and reaction times

4.4.2 DESAT filter and leading edge blanking time adjustment with ADJB

The ADJB pin configures the DESAT leading edge blanking time and DESAT filter time:

- A resistor from ADJB to GND1 sets the DESAT leading edge blanking time and the DESAT filter time used during DESAT detection
- Use resistors from the E96 resistor-series with 1% tolerance values to achieve accurate parameter configuration
- The gate driver IC reads the resistor value once during start-up
- Connecting ADJB to GND1 inhibits the gate driver operation and stops the start-up sequence
- Connecting ADJB to VCC1 disables the filtering resulting in minimum response times

Table 4 DESAT filter timing ADJB adjustment

DESAT filter time set up	stopped	0	1	2	3	4	5	6	7
Resistance at ADJB to GND1	< 1.05 kΩ or tied to GND1	1.33 kΩ	1.58 kΩ	1.91 kΩ	2.26 kΩ	2.74 kΩ	3.32 kΩ	4.02 kΩ	4.87 kΩ
typ. $t_{DESATlebl}$	inhibit gate driver operation	650 ns	650 ns	650 ns	650 ns	650 ns	650 ns	650 ns	650 ns
typ. $t_{DESATfilter}$	gate driver operation	1575 ns	1775 ns	1975 ns	2375 ns	2775 ns	3175 ns	3575 ns	3975 ns

4 Functional description

Table 4 DESAT filter timing ADJB adjustment

DESAT filter time set up	8	9	10	11	12	13	14	15	default
Resistance at <i>ADJB</i> to <i>GND1</i>	5.90 kΩ	7.15 kΩ	8.66 kΩ	10.7 kΩ	13.7 kΩ	17.4 kΩ	23.2 kΩ	28.0 kΩ	>45.3 kΩ or tied to <i>VCC1</i>
typ. $t_{DESATleb}$	1150 ns	1150 ns	1150 ns	1150 ns	1150 ns	1150 ns	1150 ns	1150 ns	400 ns
typ. $t_{DESATfilter}$	3975 ns	3575 ns	3175 ns	2775 ns	2375 ns	1975 ns	1775 ns	1575 ns	225 ns

4 Functional description

4.5 Gate driver output

The gate driver output side uses MOSFETs to provide a rail-to-rail output. Therefore, the gate drive voltage follows the supply voltage closely.

Due to the low internal voltage drop, the switching behavior of the IGBT is predominantly governed by the external gate resistor. The gate driver IC offers separate sink and source outputs to adapt the gate resistor for turn-on and turn-off separately without additional bypass components.

The cell value x in the following table is placeholder for high or low and indicates that this pin does not influence the resulting gate driver output state. The arrow (→) in cells indicate the transition initiated by the pin of the logic input and gate driver supply pins resulting in a transition to the gate driver output state as listed.

Table 5 Driver output state including transition behavior

Logic input and gate driver supply					Gate driver output	
<i>IN</i>	<i>RDYC</i>	<i>FLT_N</i>	<i>VCC1</i>	<i>VCC2</i>	<i>ON</i>	<i>OFF</i>
Static gate driver output state: on and off						
high	high	high	high	high	high	tri-state
low	high	high	high	high	tri-state	low
Transition to not ready and static not ready state						
x	high → low	high	high	high	→ tri-state	→ fault off
x	low	high	high	high	tri-state	low
Transition to fault and static fault state						
x	high	high → low	high	high	→ tri-state	→ fault off
x	high	low	high	high	tri-state	low
Transition with VCC1 power loss and unsupplied input side						
x	x	x	high → low	high	→ tri-state	→ fault off
x	x	x	low	high	tri-state	low
Transition with VCC2 power loss and unsupplied output side						
x	x	x	x	high → low	→ tri-state	→ fault off
x	x	x	x	low	tri-state	active shut down

4 Functional description

4.5.1 Turn-on behavior

The 1ED34x1Mc12M family (X3 Analog) is optimized for hard switching turn-on. A turn-on command switches the ON pin internally to VCC2.

4.5.2 Turn-off and fault turn-off behavior

The gate driver IC supports different turn-off sequences to adapt to different applications and IGBT currents during normal switching operation and in the case of a fault.

Table 6 Turn-off sequences

Turn-off reason	Turn-off sequence		Remark
	Hard switching	Soft turn-off	
normal off	X		
fault turn-off		X	adjustable via ADJA

The gate driver fault turn-off behavior can be configured with the ADJA pin. Once started, the fault turn-off sequence cannot be interrupted by an IN = low turn-off signal.

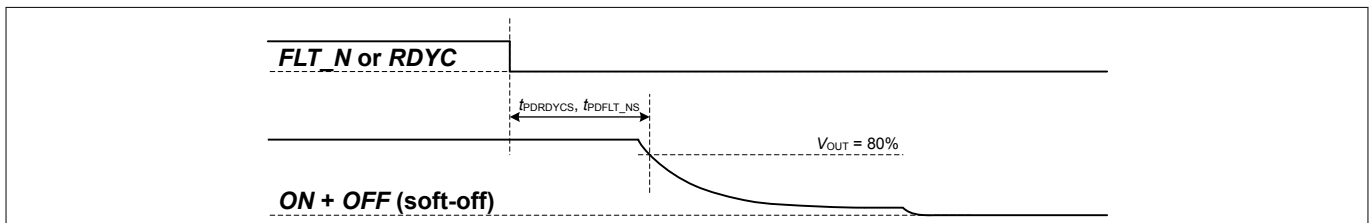

Figure 15 Fault turn-off sequence initiated by FLT_N or RDYC

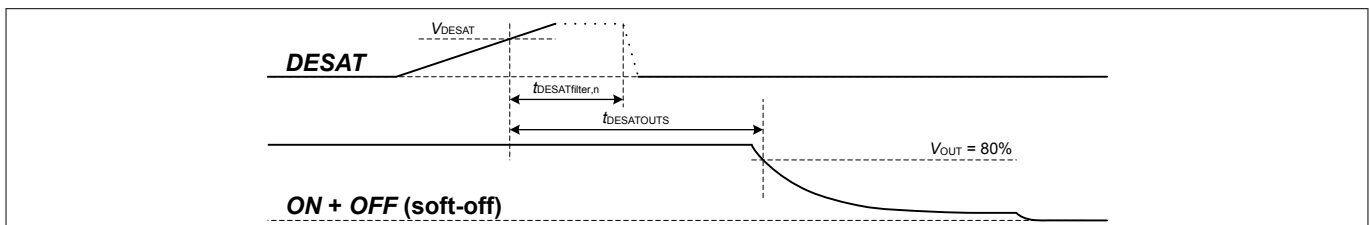

Figure 16 Fault turn-off sequence initiated by DESAT event

4.5.2.1 Hard switching turn-off

The gate driver IC supports hard switching turn-off during normal switching operation. Switching the IGBT gate off by turning on the discharge MOSFET in the output stage, the OFF pin is switched to VEE2 pin.

4.5.2.2 Soft turn-off

The soft turn-off function protects the IGBT against collector-emitter overvoltage during turn off in an overcurrent condition. It turns-off the IGBT with a reduced gate current to reduce the di/dt induced overvoltage..

The IGBT gate is connected via OFF to an internal current sink circuit. The discharge current is typically lower than the hard switch-off current used for normal operation. Since soft turn-off is a single event after a failure, the gate driver IC can handle the additional power dissipation internally.

Soft turn-off can be configured with the ADJA pin. The function is only active during fault turn-off.

The adjustable range depends on the current strength of the gate driver IC:

4 Functional description

- 1ED3431M: 15 mA - 233 mA
- 1ED3461M: 29 mA - 466 mA
- 1ED3491M: 44 mA - 699 mA

4.5.2.2.1 Soft-off current source adjustment with ADJA

The ADJA pin configures the Soft-off function and current level:

- A resistor from ADJA pin to GND1 sets the Soft-off current level for the fault-off function
- Use resistors from the E96 resistor-series with 1% tolerance values to achieve accurate parameter configuration
- The gate driver IC reads the resistor value once during start-up
- Connecting ADJA to GND1 results in a Soft-off function for fault-off with a predefined value
- Connecting ADJA to VCC1 inhibits the gate driver operation and stops the start-up sequence

Table 7 Soft-off adjustment with ADJA

Soft-off set up	default	0	1	2	3	4	5	6	7
Resistance from ADJA to GND1	< 1.05 kΩ or tied to GND1	1.33 kΩ	1.58 kΩ	1.91 kΩ	2.26 kΩ	2.74 kΩ	3.32 kΩ	4.02 kΩ	4.87 kΩ
typ. I _{CSOFF} 1ED3431M	146 mA	15 mA	29 mA	44 mA	58 mA	73 mA	87 mA	102 mA	116 mA
typ. I _{CSOFF} 1ED3461M	291 mA	29 mA	58 mA	87 mA	116 mA	146 mA	175 mA	204 mA	233 mA
typ. I _{CSOFF} 1ED3491M	437 mA	44 mA	87 mA	131 mA	175 mA	218 mA	262 mA	306 mA	349 mA

Table 7 Soft-off adjustment with ADJA

Soft-off set up	8	9	10	11	12	13	14	15	stopped
Resistance from ADJA to GND1	5.90 kΩ	7.15 kΩ	8.66 kΩ	10.7 kΩ	13.7 kΩ	17.4 kΩ	23.2 kΩ	28.0 kΩ	>45.3 kΩ or tied to VCC1
typ. I _{CSOFF} 1ED3431M	131 mA	146 mA	160 mA	175 mA	189 mA	204 mA	218 mA	233 mA	inhibit gate driver operation
typ. I _{CSOFF} 1ED3461M	262 mA	291 mA	320 mA	349 mA	379 mA	408 mA	437 mA	466 mA	
typ. I _{CSOFF} 1ED3491M	393 mA	437 mA	480 mA	524 mA	568 mA	612 mA	655 mA	699 mA	

4 Functional description

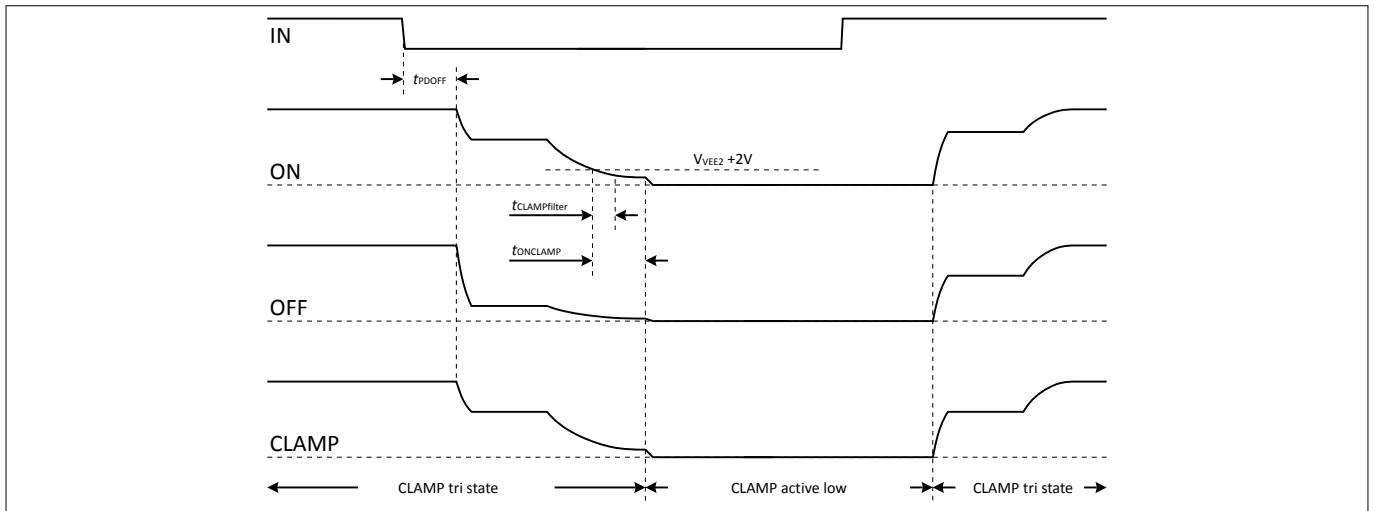

Figure 18 Direct clamp output behavior

Pre-driver output

Track inductance and clamp output resistance reduces the clamping capability for large IGBTs. In this case, select the pre-driver output product variant with an external MOSFET.

The external small signal n-channel MOSFET transistor in combination with the pre-driver output enables clamping of high gate currents. Connect the MOSFET between the *CLAMPDRV* output, *VEE2* pin, and IGBT gate. Due to the pre-driver configuration the clamp current is only limited by the external clamp MOSFET transistor. Depending on the external MOSFET a Miller current clamping up to 20 A can be reached. The clamping MOSFET has to be placed close to the IGBT gate to minimize track resistance and inductance.

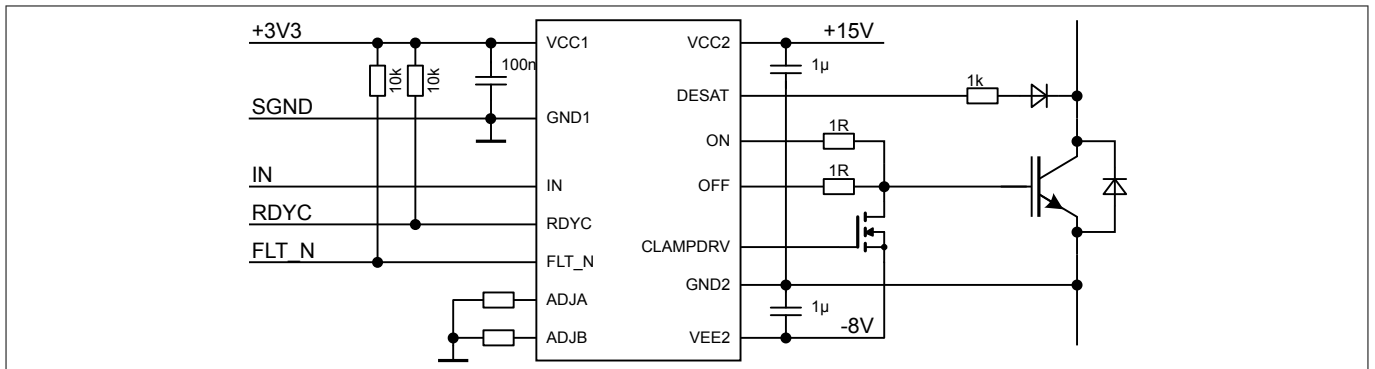

Figure 19 Application example with bipolar supply and CLAMP pre-driver output (1ED3461M, 1ED3491M)

4 Functional description

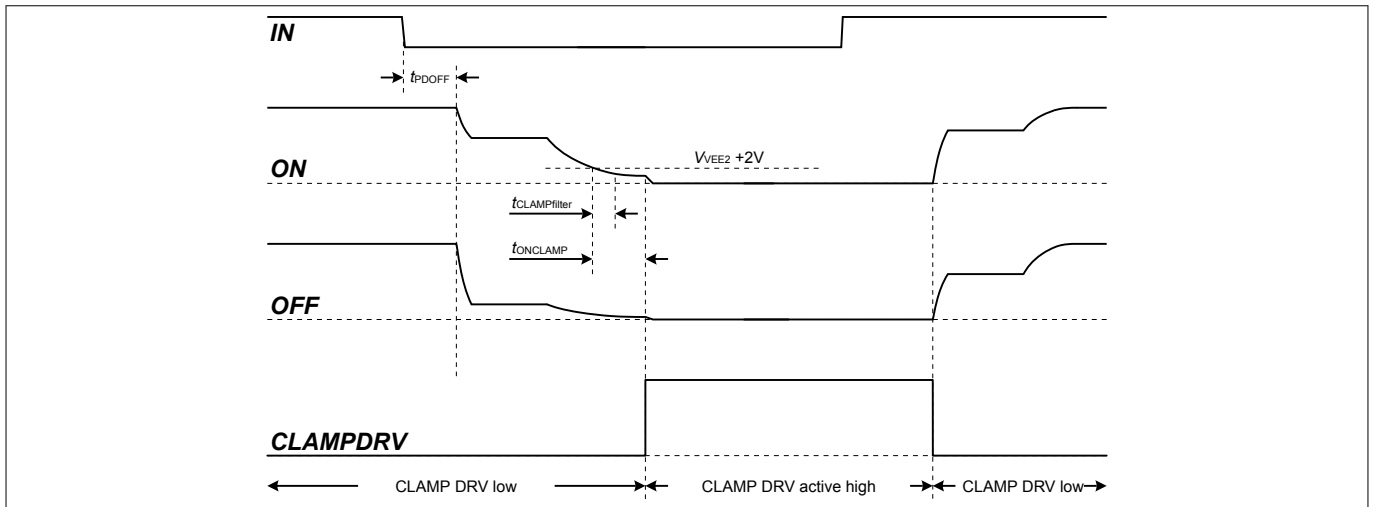

Figure 20 Clamp pre-driver output behavior

4.5.5 Switch-off timeout until forced switch-off

The gate driver IC is equipped with a switch-off timeout monitoring feature. In case the pin monitoring comparator has not registered an off-state within the timeout time this feature activates a forced switch-off. The monitoring feature secures the IGBT switch-off in case of a connection failure between the OFF output and the IGBT gate or a faulty gate resistor. In a forced switch-off all available output switch-off paths (OFF and CLAMP/CLAMPDRV) will be used to hard switch-off the IGBT after such an event.

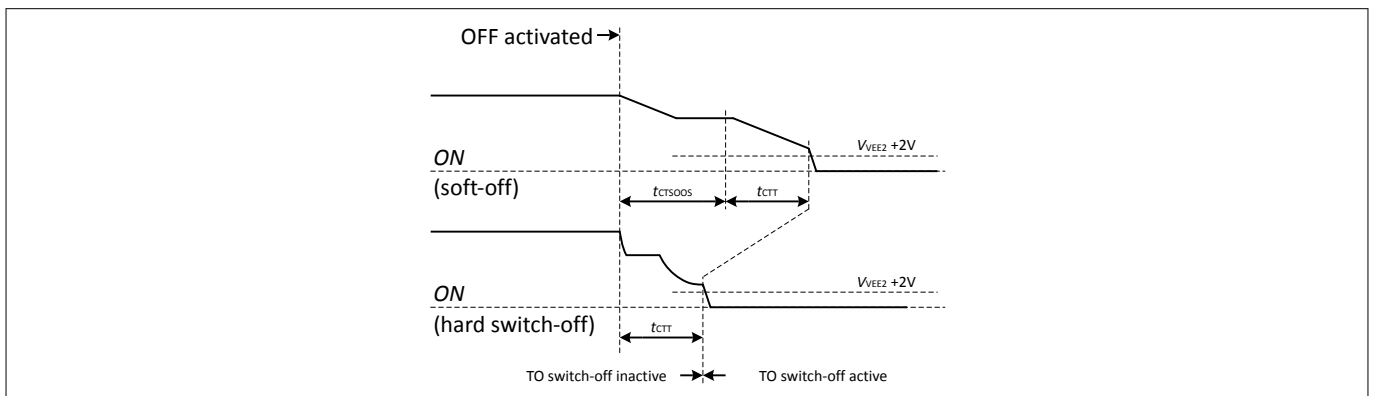

Figure 21 Switch-off timeout behavior

The timing diagram shows the switch-off timeout behavior from the moment of OFF output activation until the timeout has elapsed and the CLAMP output is activated.

4.6 Short circuit clamping

The integrated short circuit clamping diode limits the IGBT gate over voltage during a short circuit. The over voltage is typically triggered by the capacitive feedback of the Miller capacitance. The internal diodes from ON and CLAMP to VCC2 limit the gate driver voltage to a value slightly higher than the supply voltage. These diode paths are rated for a maximum current of 0.75 A and the duration of 6 μs. Add an external Schottky diode if higher currents are expected or a tighter clamping is desired. Also use an external diode if the active Miller clamping circuit uses the pre-driver output configuration.

4 Functional description

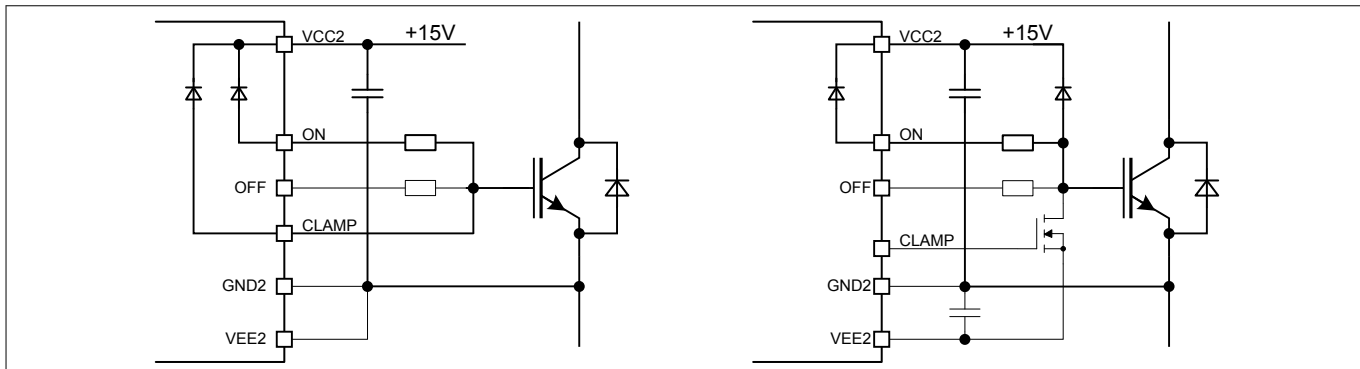

Figure 22 Short circuit clamping circuitry

5 Electrical parameters

5 Electrical parameters

5.1 Absolute maximum ratings

Note: Absolute maximum ratings are defined as ratings, which when being exceeded may lead to destruction of the integrated circuit. Unless otherwise noted all voltages are given with respect to their respective GND (GND1 for pins 1 to 8, GND2 for pins 9 to 16).

Table 8 Absolute maximum ratings

Parameter	Symbol	Values		Unit	Note / Test Condition
		Min.	Max.		
Input to output offset voltage	V_{OFFSET}	-	2300	V	$V_{\text{VEE2,max}} - V_{\text{VEE2,min}}$ with $V_{\text{VEE2,max}} \geq V_{\text{GND1}}$ $\geq V_{\text{VEE2,min}}$ ^{1) 2)}
Supply voltage input side	V_{VCC1}	-0.3	6.5	V	-
Logic input voltage (IN)	V_{LogicIN}	-0.3	6.5	V	-
Logic input voltage (RDYC, FLT_N)	V_{LogicRF}	-0.3	6.5	V	-
Logic input voltage (ADJA, ADJB)	V_{LogicAD}	-0.3	6.5	V	-
Open drain logic output current (RDYC, FLT_N)	I_{LogicOC}	-	10	mA	-
Positive supply voltage output side	V_{VCC2}	-0.3	40	V	-
Negative supply voltage output side	V_{VEE2}	-40	0.3	V	-
Maximum supply voltage difference output side ($V_{\text{VCC2}} - V_{\text{VEE2}}$)	V_{max2}	-	40	V	-
DESAT input voltage	V_{DESAT}	-0.3	$V_{\text{VCC2}} + 0.3$	V	-
CLAMP input voltage	V_{CLAMP}	$V_{\text{VEE2}} - 0.3$	$V_{\text{VCC2}} + 0.3$	V	³⁾
Maximum CLAMP output current	I_{CLAMP}	-	2.4	A	$t < 5 \mu\text{s}$
Gate driver output voltage (ON, OFF)	V_{OUT}	$V_{\text{VEE2}} - 0.3$	$V_{\text{max2}} + 0.3$	V	-
Maximum CLAMP to VCC2 diode IGBT short circuit clamping time	t_{CLP}	-	6	μs	$I_{\text{CLAMP/OUT}} = 0.75 \text{ A}$
Junction temperature	T_{J}	-40	150	°C	-
Storage temperature	T_{Stg}	-55	150	°C	-
Power dissipation, input side	$P_{\text{D,IN}}$	-	100	mW	@ $T_{\text{A}} = 25 \text{ °C}$
Power dissipation, output side	$P_{\text{D,OUT}}$	-	700	mW	@ $T_{\text{A}} = 25 \text{ °C}$ ⁴⁾
ESD capability: Human body model	V_{ESDHBM}	-	2	kV	⁵⁾
ESD capability: Charged device model	V_{ESDCDM}	-	500	V	⁶⁾

- 1) for functional operation only
- 2) See also Chapter 6 on page 41
- 3) May be exceeded during short circuit clamping.
- 4) Derating the power above 65°C with 8 mW/°C

5 Electrical parameters

- 5) According to ANSI/ESDA/JEDEC-JS-001-2017 (discharging a 100 pF capacitor through a 1.5 kΩ series resistor).
- 6) According to ANSI/ESDA/JEDEC-JS-002-2014 (TC = test condition in volt)

5.2 Thermal parameters

Thermal performance may change significantly with layout and heat dissipation of components in close proximity.

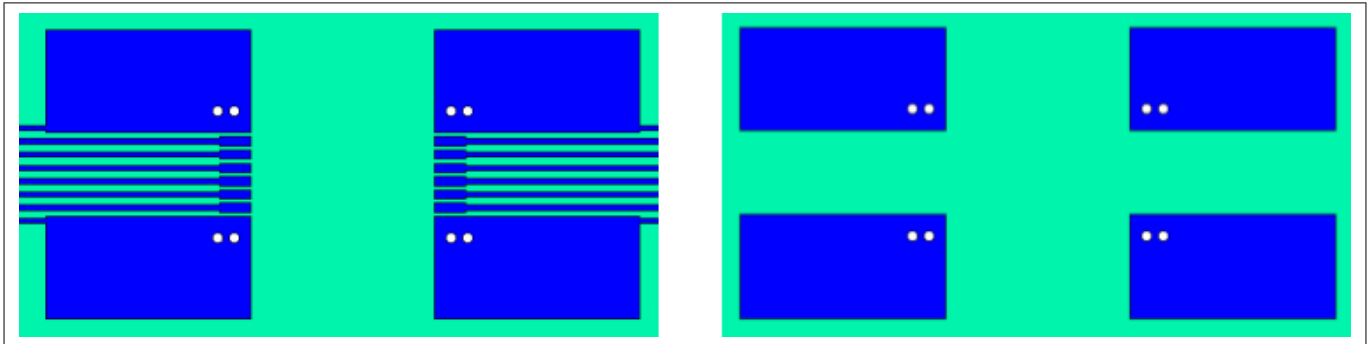

Figure 23 Reference layout for thermal data (Two layer PCB; copper thickness 35 μm; left: top layer; right: bottom layer)

The PCB layout represents the reference layout used for the thermal characterization. Pins 1 and 8 (GND1) and pins 9 and 16 (VEE2) require ground plane connections for achieving maximum power dissipation. The 1ED34x1Mc12M family (X3 Analog) is conceived to dissipate most of the heat generated through these pins.

Table 9 Thermal parameters

Parameter	Symbol	Value	Unit	Note / Test Condition
Thermal resistance junction to ambient	$R_{THJA,OUT}$	122	K/W	@ $T_A = 65^\circ\text{C}$, $P_{D,OUT} = 400\text{ mW}$, $P_{D,IN} = 50\text{ mW}$, 4 layer test PCB, PG-DSO-16
Characterization parameter junction to package top input side	Ψ_{Jtop}	8	K/W	

5.3 Operating parameters

Note: Within the operating range the IC operates as described in the functional description. Unless otherwise noted all voltages are given with respect to their respective GND (GND1 for pins 1 to 8, GND2 for pins 9 to 16).

Table 10 Operating parameters

Parameter ¹⁾	Symbol	Values		Unit	Note / Test Condition
		Min.	Max.		
Supply voltage input side	V_{VCC1}	3.0	5.5	V	–
Logic input voltages (IN, RDYC, FLT_N)	$V_{LogicIN}$	-0.3	5.5	V	–
Positive supply voltage output side	V_{VCC2}	13	25	V	–
Negative supply voltage output side	V_{VEE2}	-25	0	V	–

(table continues...)

5 Electrical parameters

Table 10 (continued) Operating parameters

Parameter ¹⁾	Symbol	Values		Unit	Note / Test Condition
		Min.	Max.		
Supply voltage difference output side ($V_{VCC2} - V_{VEE2}$)	V_{max2}	13	35	V	–
Ambient temperature	T_A	-40	125	°C	²⁾
Switching frequency	f_{SW}	0	250	kHz	max P_D applies
Common mode transient immunity	$ CMTI $	0	200	V/ns	$V_{OFFSET, test} = 1500$ V

1) Parameter is not subject to production test - verified by design/characterization

2) T_J has to be below over temperature protection temperature T_{OTPOFF}

5 Electrical parameters

5.4 Electrical characteristics

Note: The electrical characteristics include the spread of values in supply voltages, load, and junction temperatures within the operating parameters unless specified otherwise. Typical values represent the median values at $T_A = 25^\circ\text{C}$. Unless otherwise noted all voltages are given with respect to their respective GND (GND1 for pins 1 to 8, GND2 for pins 9 to 16).

5.4.1 Voltage supply

Table 11 Voltage supply

Parameter	Symbol	Values			Unit	Note or Test Condition
		Min.	Typ.	Max.		
VCC1 UVLO threshold	V_{UVLO1H}	–	2.95	3.05	V	–
	V_{UVLO1L}	2.6	2.8	–	V	–
VCC1 UVLO hysteresis ($V_{UVLO1H} - V_{UVLO1L}$)	V_{HYS1}	0.1	0.14	–	V	–
VCC1 quiescent current	I_{Q1}	–	2.4	4.0	mA	$V_{VCC1} = 3.3\text{ V}$, $IN = \text{High}$, $RDYC = \text{High}$, $FLT_N = \text{High}$
VCC1 operating current	I_{O1}	–	2.4	4.0	mA	$V_{VCC1} = 3.3\text{ V}$, $IN = 16\text{ kHz}$, 50% , $RDYC = \text{High}$, $FLT_N = \text{High}$
VCC2 UVLO threshold	$V_{UVLO2H,0}$	–	12.0	12.6	V	
	$V_{UVLO2L,0}$	10.4	11.0	–	V	
VCC2 UVLO hysteresis ($V_{UVLO2H,0} - V_{UVLO2L,0}$)	$V_{HYS2,0}$	0.75	1.0	–	V	
VEE2 not connected detection threshold	$V_{VEE2,NC}$	–	0.5	–	V	$V_{VEE2} - V_{GND2}$
VCC2 quiescent current	I_{Q2}	–	3.9	5	mA	$V_{VCC2} = 15\text{ V}$, $V_{VEE2} = -8\text{ V}$, $OUT = \text{High}$, $DESAT = \text{Low}$
VCC2 operating current	I_{O2}	–	3.9	5	mA	$V_{VCC2} = 15\text{ V}$, $V_{VEE2} = -8\text{ V}$, $OUT = 16\text{ kHz}$, 50% , $DESAT = \text{Low}$, $C_{LOAD} = 100\text{ pF}$

5 Electrical parameters

5.4.2 Logic input and output

Table 12 Logic input and output

Parameter	Symbol	Values			Unit	Note or Test Condition
		Min.	Typ.	Max.		
Logic low input voltage (<i>IN</i> , <i>RDYC</i> , <i>FLT_N</i>)	$V_{LogicINL}$	–	–	30	%	of V_{CC1}
Logic high input voltage (<i>IN</i> , <i>RDYC</i> , <i>FLT_N</i>)	$V_{LogicINH}$	70	–	–	%	of V_{CC1}
Logic low output voltage (<i>RDYC</i> , <i>FLT_N</i>)	V_{RDYC5} , V_{FLT_N5}	–	–	300	mV	$I_{SINK} = 5 \text{ mA}$
Logic input pull down resistor (<i>IN</i>)	R_{INPD}	33	40	47	k Ω	–
Logic input pull down resistor (<i>RDYC</i> , <i>FLT_N</i>)	R_{RDYCPD} , R_{FLT_NPD}	0.8	1.0	1.2	M Ω	–

5.4.3 Analog input

Resistor values outside of the 1% tolerance range results in the gate driver IC selecting either the lower or higher step for the corresponding function.

Table 13 Analog input

Parameter ¹⁾	Symbol	Values			Unit	Note or Test Condition
		Min.	Typ.	Max.		
Analog input resistor (<i>ADJA</i> , <i>ADJB</i>)	R_{ADJx0}	–	1.33	–	k Ω	all resistor values are from the E96-series with 1% tolerance
	R_{ADJx1}	–	1.58	–		
	R_{ADJx2}	–	1.91	–		
	R_{ADJx3}	–	2.26	–		
	R_{ADJx4}	–	2.74	–		
	R_{ADJx5}	–	3.32	–		
	R_{ADJx6}	–	4.02	–		
	R_{ADJx7}	–	4.87	–		
	R_{ADJx8}	–	5.90	–		
	R_{ADJx9}	–	7.15	–		
	R_{ADJx10}	–	8.66	–		
	R_{ADJx11}	–	10.7	–		
	R_{ADJx12}	–	13.7	–		
	R_{ADJx13}	–	17.4	–		
	R_{ADJx14}	–	23.2	–		
R_{ADJx15}	–	28.0	–			

5 Electrical parameters

1) Parameter is not subject to production test - verified by design/characterization

5 Electrical parameters

5.4.4 Gate driver

Note: High and low level output currents are absolute values without an information of current direction.

Table 14 Gate driver

Parameter	Symbol	Values			Unit	Note or Test Condition
		Min.	Typ.	Max.		
High level output voltage	V_{ON0}	–	$V_{VCC2} + 0.87$	$V_{VCC2} + 1.01$	V	$I_{ON} = 500 \text{ mA}^{1)}$
High level output peak current 1ED3431M	I_{ON}	2.6	3.8	–	A	$^{2) 3)} C_{LOAD} = 33 \text{ nF}$
High level output on resistance 1ED3431M	$R_{DSON,H}$	0.51	1.12	2.24	Ω	$I_{ON} = 67 \text{ mA}^{3)}$
Low level output peak current 1ED3431M	I_{OFF}	2.0	2.5	–	A	$^{2) 4)} C_{LOAD} = 33 \text{ nF}$
Low level output on resistance 1ED3431M	$R_{DSON,L}$	0.31	0.82	1.64	Ω	$I_{OFF} = 67 \text{ mA}^{4)}$
High level output peak current 1ED3461M	I_{ON}	5.2	7.5	–	A	$^{2) 3)} C_{LOAD} = 68 \text{ nF}$
High level output on resistance 1ED3461M	$R_{DSON,H}$	0.26	0.56	1.13	Ω	$I_{ON} = 133 \text{ mA}^{3)}$
Low level output peak current 1ED3461M	I_{OFF}	4.0	5.0	–	A	$^{2) 4)} C_{LOAD} = 68 \text{ nF}$
Low level output on resistance 1ED3461M	$R_{DSON,L}$	0.16	0.41	0.83	Ω	$I_{OFF} = 133 \text{ mA}^{4)}$
High Level output peak current 1ED3491M	I_{ON}	7.9	11	–	A	$^{2) 3)} C_{LOAD} = 100 \text{ nF}$
High level output on resistance 1ED3491M	$R_{DSON,H}$	0.17	0.38	0.75	Ω	$I_{ON} = 200 \text{ mA}^{3)}$
Low Level output peak current 1ED3491M	I_{OFF}	6.0	7.5	–	A	$^{2) 4)} C_{LOAD} = 100 \text{ nF}$
Low level output on resistance 1ED3491M	$R_{DSON,L}$	0.11	0.28	0.55	Ω	$I_{OFF} = 200 \text{ mA}^{4)}$
Active Shut Down Voltage OFF 1ED3431M	$V_{ACTSD}^{5)}$	–	–	$V_{VEE2} + 2.4$	V	$I_{OUT} = 67 \text{ mA}, V_{VCC2}$ open
Active Shut Down Voltage OFF 1ED3461M	$V_{ACTSD}^{5)}$	–	–	$V_{VEE2} + 2.4$	V	$I_{OUT} = 133 \text{ mA}, V_{VCC2}$ open
Active Shut Down Voltage OFF 1ED3491M	$V_{ACTSD}^{5)}$	–	–	$V_{VEE2} + 2.4$	V	$I_{OUT} = 200 \text{ mA}, V_{VCC2}$ open

1) Integrated diode ON vs. VCC2 clamping test

2) Parameter is not subject to production test - verified by design/characterization

3) $I_N = \text{High}, ON = \text{High}; V_{CC2-ON} = 15 \text{ V}; R_G = 0.1 \Omega; V_{CC2} = 15 \text{ V}; V_{EE2} = -8 \text{ V}$

4) $I_N = \text{Low}, OFF = \text{Low}; OFF-VEE2 = 15 \text{ V}; R_G = 0.1 \Omega; V_{CC2} = 15 \text{ V}; V_{EE2} = -8 \text{ V}$

5 Electrical parameters

5) With reference to V_{EE2}

5.4.5 Active Miller clamp

Table 15 Active Miller clamp

Parameter	Symbol	Values			Unit	Note or Test Condition
		Min.	Typ.	Max.		
High level clamp voltage	$V_{CLAMPH0}$	–	$V_{VCC2} + 1.5$	$V_{VCC2} + 1.63$	V	$I_{CLAMP} = 500 \text{ mA}^{1) 2)}$
	$V_{CLAMPH1}$	–	$V_{VCC2} + 0.9$	$V_{VCC2} + 1.1$	V	$I_{CLAMP} = 50 \text{ mA}^{1) 2)}$
Clamp-driver high level output voltage (1ED3461M, 1ED3491M)	$V_{CLAMPDH1}$	$V_{VEE2} + 7.5$	$V_{VEE2} + 9.5$	$V_{VEE2} + 11.5$	V	$I_{CLAMP} = 5 \text{ mA}^{3)}$
	$V_{CLAMPDH2}$	$V_{VEE2} + 4.5$	$V_{VEE2} + 6.7$	–	V	$I_{CLAMP} = 50 \text{ mA}^{3)}$
Clamp-driver high level output peak current (1ED3461M, 1ED3491M)	I_{CLAMP}	0.20	0.27	–	A	⁴⁾ $V_{CC2} = 15 \text{ V}$; $V_{EE2} = 0 \text{ V}$; $C_{CLAMP} = 100 \text{ nF}$; $R_{CLAMP} = 1 \Omega$
Clamp/Clamp-driver output low level current	$I_{CLAMPL,2}$	1.1	1.8	–	A	⁴⁾ $V_{CC2} = 15 \text{ V}$; $V_{EE2} = 0 \text{ V}$; $V_{CLAMP} = 2 \text{ V}$; $C_{CLAMP} = 100 \text{ nF}$; $R_{CLAMP} = 0.1 \Omega$
Clamp/Clamp-driver output low level current	$I_{CLAMPL,5}$	2.2	3.5	–	A	⁴⁾ $V_{CC2} = 15 \text{ V}$; $V_{EE2} = 0 \text{ V}$; $V_{CLAMP} = 5 \text{ V}$; $C_{CLAMP} = 100 \text{ nF}$; $R_{CLAMP} = 0.1 \Omega$
Clamp/Clamp-driver output low level ON resistance	$R_{DSON,CLP}$	0.50	0.85	1.35	Ω	$I_{CLAMPL} = 200 \text{ mA}$
Clamp threshold voltage	V_{ON_CLAMP}	1.5	2.0	2.5	V	Related to V_{EE2}
Clamp filter time	$t_{CLAMPfilter}$	195	235	275	ns	
CLAMP reaction time in CLAMP mode	t_{CLAMP_ON}	16 + $t_{CLAMPfilter}$	23 + $t_{CLAMPfilter}$	35 + $t_{CLAMPfilter}$	ns	^{4) 5)} $C_{LOAD} = 100 \text{ pF}$
CLAMP reaction time in CLAMP driver mode	t_{CLAMPD_ON}	24 + $t_{CLAMPfilter}$	35 + $t_{CLAMPfilter}$	53 + $t_{CLAMPfilter}$	ns	^{4) 6)} $C_{LOAD} = 100 \text{ pF}$
Switch-off time-out time	t_{CTT}	–	2.4	–	μs	⁴⁾
Switch-off time-out soft-off offset time	t_{CTSOOS}	–	2.4	–	μs	⁴⁾ additional time-out delay during soft-off

- 1) Integrated diode CLAMP vs. VCC2 clamping test
- 2) only valid for direct clamping: $IN = \text{High}$, $OUT = \text{High}$
- 3) only valid for clamp pre-driver output: $IN = \text{Low}$, $OUT = \text{Low}$
- 4) Parameter is not subject to production test - verified by design/characterization
- 5) CLAMP mode reaction time specified with 3.3 k Ω pull-up from CLAMP to 3.3 V, from CLAMP threshold until reaching 0.8 V (falling) at CLAMP pin

5 Electrical parameters

- 6) CLAMP driver mode reaction time specified from CLAMP threshold until reaching 0.8 V (rising) at CLAMP(DRV) pin

5.4.6 Dynamic characteristics

Dynamic characteristics are measured with $V_{VCC1} = 5\text{ V}$, $V_{VCC2} = 15\text{ V}$ and $V_{VEE2} = -8\text{ V}$ unless specified otherwise.

Table 16 Dynamic characteristics

Parameter	Symbol	Values			Unit	Note or Test Condition
		Min.	Typ.	Max.		
Input pulse suppression time <i>IN</i>	t_{INMIN}	98	103	108	ns	–
Input pulse suppression time <i>RDYC/FLT_N</i> for enable / fault off	$t_{RDYCMIN}$, t_{FLT_NMIN}	85	100	115	ns	–
Input pulse width <i>RDYC</i> for <i>FLT_N</i> reset (Fault clear time)	t_{CLRMIN}	–	1.0	1.2	μs	
Input <i>IN</i> to output propagation delay <i>ON</i>	t_{PDON}	226	244	270	ns	$C_{LOAD} = 100\text{ pF}$, $V_{IN} = 70\%$, $V_{OUT} = 20\%$
Input <i>IN</i> to output propagation delay <i>OFF</i>	t_{PDOFF}	218	236	262	ns	$C_{LOAD} = 100\text{ pF}$, $V_{IN} = 30\%$, $V_{OUT} = 80\%$
Input to output propagation delay distortion ($t_{PDOFF} - t_{PDON}$)	t_{PDISTO}	-23	-8	7	ns	$C_{LOAD} = 100\text{ pF}$
Input <i>IN</i> to output propagation delay distortion between any devices ($t_{PDON} - t_{PDON}$) or ($t_{PDOFF} - t_{PDOFF}$)	t_{PDD}	–	–	30	ns	¹⁾ same conditions (V_{IN} , V_{VCC1} , V_{VCC2} and V_{VEE2} , C_{LOAD} , T_A)
State synchronization time between input and output	t_{SSIO}	–	–	13	μs	¹⁾
Input <i>RDYC</i> to output on propagation delay	t_{PDRDYC}	447	523	600	ns	$C_{LOAD} = 100\text{ pF}$; <i>IN</i> high; $V_{RDYC} = 70\%$, $V_{OUT} = 20\%$
Input <i>RDYC</i> or <i>FLT_N</i> to Soft-off output propagation delay	$t_{PDRDYCS}$, t_{PDFLT_NS}	323	361	407	ns	$C_{LOAD} = 100\text{ pF}$, $V_{Signal} = 30\%$, $V_{OUT} = 80\%$, Soft-off function $I_{CSOFF,15}$
Input <i>RDYC</i> or <i>FLT_N</i> to hard switch-off output propagation delay	$t_{PDRDYCH}$, t_{PDFLT_NH}	303	342	384	ns	$C_{LOAD} = 100\text{ pF}$, $V_{Signal} = 30\%$, $V_{OUT} = 80\%$, OFF function
Rise time 1ED3431M	t_{RISE}	–	15	30	ns	$C_{LOAD} = 1\text{ nF}$, V_{OUT} : 20% to 80%

(table continues...)

5 Electrical parameters

Table 16 (continued) Dynamic characteristics

Parameter	Symbol	Values			Unit	Note or Test Condition
		Min.	Typ.	Max.		
Fall time 1ED3431M	t_{FALL}	–	15	30	ns	$C_{LOAD} = 1 \text{ nF}$, V_{OUT} : 80% to 20%
Rise time 1ED3461M	t_{RISE}	–	15	30	ns	$C_{LOAD} = 2.2 \text{ nF}$, V_{OUT} : 20% to 80%
Fall Time 1ED3461M	t_{FALL}	–	15	30	ns	$C_{LOAD} = 2.2 \text{ nF}$, V_{OUT} : 80% to 20%
Rise Time 1ED3491M	t_{RISE}	–	15	30	ns	$C_{LOAD} = 3.3 \text{ nF}$, V_{OUT} : 20% to 80%
Fall Time 1ED3491M	t_{FALL}	–	15	30	ns	$C_{LOAD} = 3.3 \text{ nF}$, V_{OUT} : 80% to 20%

1) Parameter is not subject to production test - verified by design/characterization

5.4.7 Desaturation protection

All parameters valid for $VCC1 = 5 \text{ V}$, $VCC2 = 15 \text{ V}$, and $VEE2 = 0 \text{ V}$ unless specified otherwise.

Table 17 Desaturation protection

Parameter	Symbol	Values			Unit	Note or Test Condition
		Min.	Typ.	Max.		
DESAT charge current	I_{DESATC}	470	500	525	μA	$V_{DESAT} = 0 \text{ V}$
DESAT voltage divider resistance	R_{DVD}	259	312.5	366	$\text{k}\Omega$	between <i>DESAT</i> and <i>GND2</i> pins
DESAT clamp and discharge ON resistance	$R_{DSON,D}$	–	7.7	25.0	Ω	$I_{DESATD} = 200 \text{ mA}$
DESAT threshold level	V_{DESAT}	8.88	9.18	9.48	V	–
DESAT leading edge blanking time	$t_{DESATleb,d}$	356	400	444	ns	<i>ADJB</i> depending, V_{ON} 20% rising to $V_{DESAT} = 1 \text{ V}$, $C_{LOAD} = 100 \text{ pF}$, $C_{DESAT} = 2 \text{ pF}$,
	$t_{DESATleb,s}$	597	650	703	ns	
	$t_{DESATleb,l}$	1077	1150	1223	ns	
DESAT filter time (default)	$t_{DESATfilter,def}$	190	225	263	ns	<i>ADJB</i> = $VCC1$
DESAT filter time (<i>ADJB</i> adjustable)	$t_{DESATfilter,A}$	1476	1575	1684	ns	<i>ADJB</i> depending
	$t_{DESATfilter,B}$	1667	1775	1895	ns	
	$t_{DESATfilter,C}$	1857	1975	2105	ns	
	$t_{DESATfilter,D}$	2238	2375	2526	ns	
	$t_{DESATfilter,E}$	2619	2775	2947	ns	
	$t_{DESATfilter,F}$	3000	3175	3368	ns	

(table continues...)

5 Electrical parameters

Table 17 (continued) Desaturation protection

Parameter	Symbol	Values			Unit	Note or Test Condition
		Min.	Typ.	Max.		
	$t_{\text{DESATfilter,G}}$	3381	3575	3789	ns	
	$t_{\text{DESATfilter,H}}$	3762	3975	4211	ns	
DESAT sense to <i>FLT_N</i> low delay	t_{DESATFLT}	623	743	883	ns	$V_{\text{FLT_N}} = 30\%$, $I_{\text{FLT_N}} = 5 \text{ mA}$, $t_{\text{DESATfilter,def}}$, $C_{\text{FLT_N}} = 100 \text{ pF}$
DESAT sense to <i>OFF</i> low delay, Soft-off	$t_{\text{DESATOUTS}}$	287 + $t_{\text{DESATfilter}}$	333 + $t_{\text{DESATfilter}}$	382 + $t_{\text{DESATfilter}}$	ns	$V_{\text{OUT}} = 80\%$, $C_{\text{LOAD}} = 100 \text{ pF}$, $I_{\text{CSOFF,15}}$

5 Electrical parameters

5.4.8 Soft-off current source

Soft-off current source values specified at OFF pin at $V_{OFF} = 3\text{ V}$ with unipolar supply of $V_{VCC2} = 15\text{ V}$.

Table 18 Current source turn-off

Parameter	Symbol	Values			Unit	Note or Test Condition
		Min.	Typ.	Max.		
Soft-off current source current 1ED3431M	$I_{CSOFF,0}$	10	15	19	mA	depends on resistor value at ADJA
	$I_{CSOFF,1}$	24	29	36	mA	
	$I_{CSOFF,2}$	35	44	52	mA	
	$I_{CSOFF,3}$	47	58	70	mA	
	$I_{CSOFF,4}$	58	73	87	mA	
	$I_{CSOFF,5}$	70	87	105	mA	
	$I_{CSOFF,6}$	82	102	122	mA	
	$I_{CSOFF,7}$	93	116	140	mA	
	$I_{CSOFF,8}$	105	131	157	mA	
	$I_{CSOFF,9}$	116	146	175	mA	
	$I_{CSOFF,10}$	128	160	192	mA	
	$I_{CSOFF,11}$	140	175	210	mA	
	$I_{CSOFF,12}$	151	189	227	mA	
	$I_{CSOFF,13}$	163	204	245	mA	
	$I_{CSOFF,14}$	175	218	262	mA	
$I_{CSOFF,15}$	186	233	280	mA		
Soft-off current source current 1ED3461M	$I_{CSOFF,0}$	22	29	36	mA	depends on resistor value at ADJA
	$I_{CSOFF,1}$	45	58	72	mA	
	$I_{CSOFF,2}$	70	87	105	mA	
	$I_{CSOFF,3}$	93	116	140	mA	
	$I_{CSOFF,4}$	116	146	175	mA	
	$I_{CSOFF,5}$	140	175	210	mA	
	$I_{CSOFF,6}$	163	204	245	mA	
	$I_{CSOFF,7}$	186	233	280	mA	
	$I_{CSOFF,8}$	210	262	314	mA	
	$I_{CSOFF,9}$	233	291	349	mA	
	$I_{CSOFF,10}$	256	320	384	mA	
	$I_{CSOFF,11}$	280	349	419	mA	
	$I_{CSOFF,12}$	303	379	454	mA	
	$I_{CSOFF,13}$	326	408	489	mA	
	$I_{CSOFF,14}$	349	437	524	mA	

(table continues...)

5 Electrical parameters

Table 18 (continued) Current source turn-off

Parameter	Symbol	Values			Unit	Note or Test Condition
		Min.	Typ.	Max.		
	$I_{CSOFF,15}$	373	466	559	mA	
Soft-off current source current 1ED3491M	$I_{CSOFF,0}$	34	44	54	mA	depends on resistor value at ADJA
	$I_{CSOFF,1}$	70	87	105	mA	
	$I_{CSOFF,2}$	105	131	157	mA	
	$I_{CSOFF,3}$	140	175	210	mA	
	$I_{CSOFF,4}$	175	218	262	mA	
	$I_{CSOFF,5}$	210	262	314	mA	
	$I_{CSOFF,6}$	245	306	367	mA	
	$I_{CSOFF,7}$	280	349	419	mA	
	$I_{CSOFF,8}$	314	393	472	mA	
	$I_{CSOFF,9}$	349	437	524	mA	
	$I_{CSOFF,10}$	384	480	577	mA	
	$I_{CSOFF,11}$	419	524	629	mA	
	$I_{CSOFF,12}$	454	568	681	mA	
	$I_{CSOFF,13}$	489	612	734	mA	
	$I_{CSOFF,14}$	524	655	786	mA	
$I_{CSOFF,15}$	559	699	839	mA		

5.4.9 Over-temperature protection

Table 19 Over-temperature protection

Parameter ¹⁾	Symbol	Values			Unit	Note or Test Condition
		Min.	Typ.	Max.		
Over-temperature protection level	T_{OTPOFF}	150	160	170	°C	

1) Parameter is not subject to production test - verified by design/characterization

6 Insulation characteristics

6 Insulation characteristics

The following isolation classes are available for the 1ED34x1Mc12M family (X3 Analog).

Table 20 Product isolation classes

Product name	Marking	Insulation characteristics	Values specified in	UL values
1ED34x1MU12M	34x1MU12	UL 1577 certified insulation	-	Table 23
1ED34x1MC12M	34x1MC12	Reinforced insulation	Table 22	Table 23

Table 21 Safety limiting values

This coupler is suitable for rated insulation only within the given safety ratings. Compliance with the safety ratings shall be ensured by means of suitable protective circuits.

Description	Symbol	Characteristic	Unit
Maximum ambient safety temperature	T_S	150	°C
Maximum input-side power dissipation at $T_A = 25^\circ\text{C}$	P_{SI}	100	mW
Maximum output-side power dissipation at $T_A = 25^\circ\text{C}^{1)}$	P_{SO}	1000	mW
Maximum driver output current (ON, OFF) ²⁾	I_{OUT}		A
1ED3431MC		2.4	
1ED3461MC		4.8	
1ED3491MC		7.2	

1) IC output-side power dissipation is derated linearly at 8 mW/°C above 65 °C

2) Maximum pulse length of $t = 5 \mu\text{s}$

6.1 Certified according to VDE 0884-11 reinforced insulation (Certificate no. 40053980)

Valid for parts with part name 1ED34x1MC12M, x indicate different variants.

This coupler is suitable for safe electrical insulation only within the safety ratings. Compliance with the safety ratings shall be ensured by means of suitable protective circuits.

Table 22 Reinforced insulation according to VDE 0884-11

Description	Symbol	Characteristic	Unit
Installation classification per EN 60664-1, Table 1 for rated mains voltage $\leq 150 \text{ V (rms)}$ for rated mains voltage $\leq 300 \text{ V (rms)}$ for rated mains voltage $\leq 600 \text{ V (rms)}$ for rated mains voltage $\leq 1000 \text{ V (rms)}$		I-IV I-IV I-III I-II	-
Climatic classification		40/125/21	-
Pollution degree (EN 60664-1)		2	-
Minimum external clearance	CLR	>8	mm
Minimum external creepage	CPG	>8	mm
Minimum comparative tracking index	CTI	400	-

(table continues...)

6 Insulation characteristics

Table 22 (continued) Reinforced insulation according to VDE 0884-11

Description	Symbol	Characteristic	Unit
Apparent charge, method a $V_{pd(ini),a} = V_{IOTM}$, $V_{pd(m)} = 1.6 \times V_{IORM}$, $t_{ini} = 1 \text{ min}$	q_c	<5	pC
Apparent charge, method b $V_{pd(ini),b} = V_{IOTM} \times 1.2$, $V_{pd(m)} = 1.875 \times V_{IORM}$, $t_{ini} = 1 \text{ s}$	q_c	<5	pC
Isolation resistance at $T_{A,max}$	R_{IO}	$> 10^{11}$	Ω
Isolation resistance at T_S	$R_{IO,S}$	$> 10^9$	Ω
Maximum rated transient isolation voltage	V_{IOTM}	8000	V (peak)
Maximum repetitive insulation voltage	V_{IORM}	1767	V (peak)
Maximum surge isolation voltage for reinforced isolation $V_{TEST} = V_{IOSM} \times 1.6$	V_{IOSM}	6875	V (peak)
Insulation capacitance	C_{IO}	1.7	pF

6.2 Recognized under UL 1577 (File E311313)

Table 23 Recognized under UL 1577

Description	Symbol	Characteristic	Unit
Insulation withstand voltage/1 min	V_{ISO}	5700	V (rms)
Insulation test voltage/1 s	$V_{ISO,TEST}$	6840	V (rms)

7 Package information

7 Package information

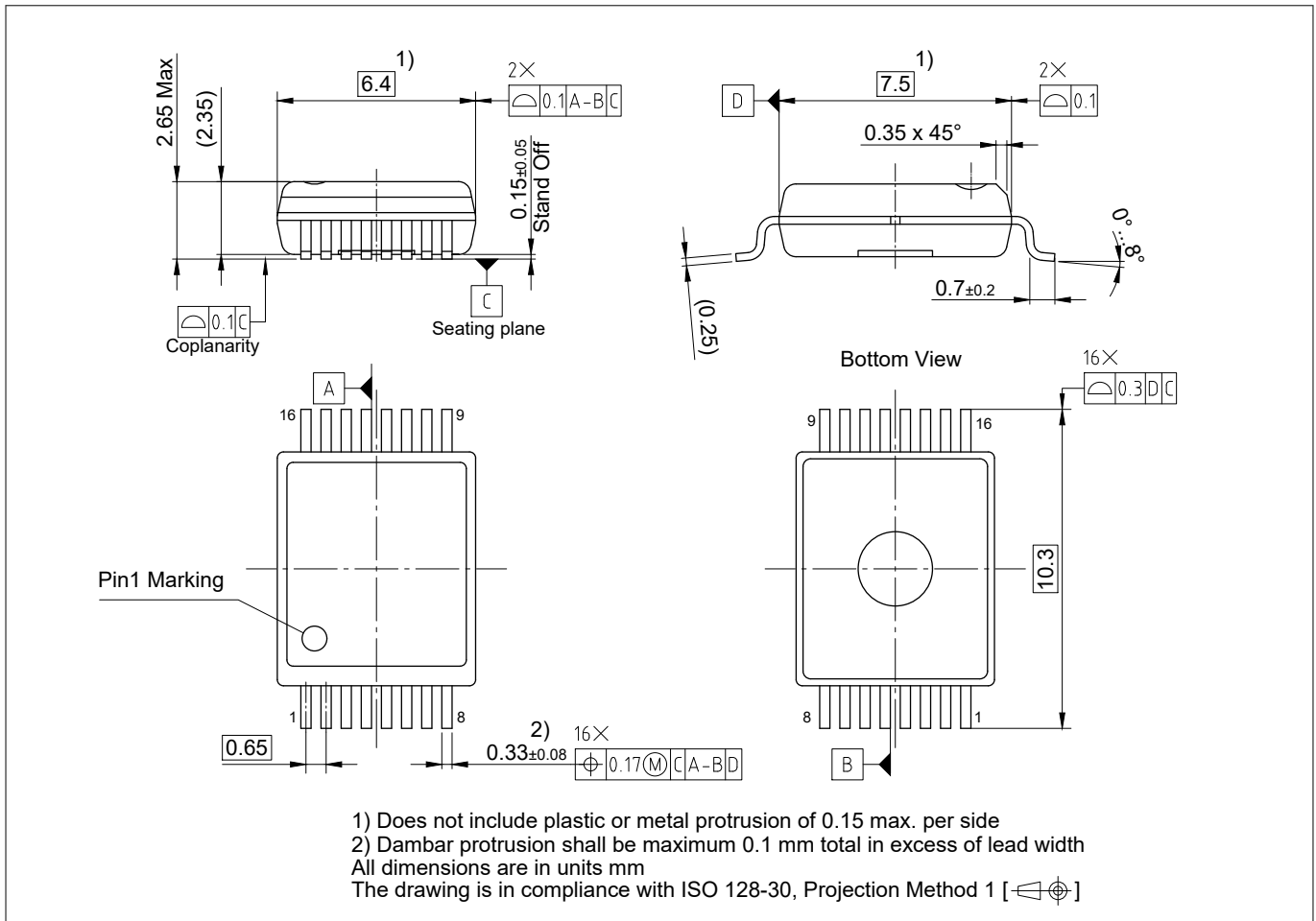

Figure 24 PG-DSO-16-28/33 - 300 mil 16-pin fine pitch plastic green dual small outline package

8 Application notes

8 Application notes

8.1 Reference layout for thermal data

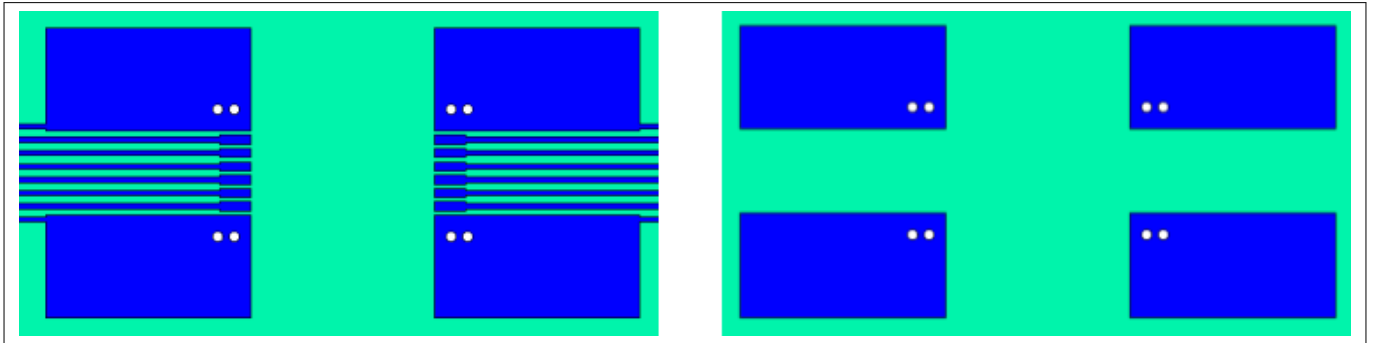

Figure 25 Reference layout for thermal data (Two layer PCB; copper thickness 35 µm; left: top layer; right: bottom layer)

The PCB layout represents the reference layout used for the thermal characterization. Pins 1 and 8 (*GND1*) and pins 9 and 16 (*VEE2*) require ground plane connections for achieving maximum power dissipation. The 1ED34x1Mc12M family (X3 Analog) is conceived to dissipate most of the heat generated through these pins.

8.2 Printed circuit board guidelines

Following factors should be taken into account for an optimum PCB layout.

- Sufficient spacing should be kept between high voltage isolated side and low voltage side circuits.
- The same minimum distance between two adjacent high-side isolated parts of the PCB should be maintained to increase the effective isolation and reduce parasitic coupling.
- In order to ensure low supply ripple and clean switching signals, bypass capacitor trace lengths should be kept as short as possible.

Revision history

Revision history

Reference	Description
v2.1 (2021-02-15)	<ul style="list-style-type: none"> • Change footnotes to table notes • added param V_{OFFSET} • update package drawing to latest revision • update certification status
(2021-09-01)	New version number schema: Target/Preliminary datasheet: 0.XY; Final datasheet: 1.XY
1.10 (2021-10-08)	<ul style="list-style-type: none"> • Certification information update (VDE certification) • Fix unit and conditions in certification table according to standards • Related product table update

Trademarks

All referenced product or service names and trademarks are the property of their respective owners.

Edition 2021-10-08

Published by
Infineon Technologies AG
81726 Munich, Germany

© 2021 Infineon Technologies AG
All Rights Reserved.

Do you have a question about any
aspect of this document?
Email: erratum@infineon.com

Document reference
IFX-fiz1584344472005

IMPORTANT NOTICE

The information given in this document shall in no event be regarded as a guarantee of conditions or characteristics ("Beschaffheitsgarantie").

With respect to any examples, hints or any typical values stated herein and/or any information regarding the application of the product, Infineon Technologies hereby disclaims any and all warranties and liabilities of any kind, including without limitation warranties of non-infringement of intellectual property rights of any third party.

In addition, any information given in this document is subject to customer's compliance with its obligations stated in this document and any applicable legal requirements, norms and standards concerning customer's products and any use of the product of Infineon Technologies in customer's applications.

The data contained in this document is exclusively intended for technically trained staff. It is the responsibility of customer's technical departments to evaluate the suitability of the product for the intended application and the completeness of the product information given in this document with respect to such application.



WARNINGS

Due to technical requirements products may contain dangerous substances. For information on the types in question please contact your nearest Infineon Technologies office.



Except as otherwise explicitly approved by Infineon Technologies in a written document signed by authorized representatives of Infineon Technologies, Infineon Technologies' products may not be used in any applications where a failure of the product or any consequences of the use thereof can reasonably be expected to result in personal injury.

Looking for pricing, stock, or lifecycle information?

Click below to explore more details on WIN SOURCE:

-  [View 1ED3491MC12MXUMA1 on WIN SOURCE](#)
-  [Infineon Technologies Information](#)

Optimize Your Supply Chain with WIN SOURCE Solutions

-  Global Sourcing Solution
-  Obsolete Management
-  Cost Control Management
-  Shortage Management
-  Alternative Solution
-  Excess Inventory Management