



**THE DATASHEET OF  
CY62157EV30LL-45BVXI**



## Features

- Thin small outline package (TSOP) I package configurable as 512K × 16 or 1M × 8 static RAM (SRAM)
- High speed: 45 ns
- Temperature ranges
  - Industrial: -40 °C to +85 °C
  - Automotive-A: -40 °C to +85 °C
  - Automotive-E: -40 °C to +125 °C
- Wide voltage range: 2.20 V to 3.60 V
- Pin compatible with CY62157DV30
- Ultra low standby power
  - Typical standby current: 2 μA
  - Maximum standby current: 8 μA (Industrial)
- Ultra low active power
  - Typical active current: 1.8 mA at f = 1 MHz
- Easy memory expansion with  $\overline{CE}_1$ ,  $CE_2$ , and  $\overline{OE}$  features
- Automatic power down when deselected
- Complementary Metal Oxide Semiconductor (CMOS) for optimum speed and power
- Available in Pb-free and non Pb-free 48-ball very fine-pitch ball grid array (VFBGA), Pb-free 44-pin thin small outline package (TSOP) II and 48-pin TSOP I packages

## Functional Description

The CY62157EV30 is a high performance CMOS static RAM organized as 512K words by 16 bits. This device features advanced circuit design to provide ultra low active current. This is ideal for providing More Battery Life™ (MoBL®) in portable applications such as cellular telephones. The device also has an automatic power down feature that significantly reduces power consumption when addresses are not toggling. Place the device into standby mode when deselected ( $\overline{CE}_1$  HIGH or  $CE_2$  LOW or both  $\overline{BHE}$  and  $\overline{BLE}$  are HIGH). The input or output pins (I/O<sub>0</sub> through I/O<sub>15</sub>) are placed in a high impedance state when the device is deselected ( $\overline{CE}_1$  HIGH or  $CE_2$  LOW), the outputs are disabled ( $\overline{OE}$  HIGH), Byte High Enable and Byte Low Enable are disabled ( $\overline{BHE}$ ,  $\overline{BLE}$  HIGH), or a write operation is active ( $CE_1$  LOW,  $CE_2$  HIGH and  $WE$  LOW).

To write to the device, take Chip Enable ( $\overline{CE}_1$  LOW and  $CE_2$  HIGH) and Write Enable ( $WE$ ) inputs LOW. If Byte Low Enable ( $\overline{BLE}$ ) is LOW, then data from I/O pins (I/O<sub>0</sub> through I/O<sub>7</sub>) is written into the location specified on the address pins (A<sub>0</sub> through A<sub>18</sub>). If Byte High Enable ( $\overline{BHE}$ ) is LOW, then data from I/O pins (I/O<sub>8</sub> through I/O<sub>15</sub>) is written into the location specified on the address pins (A<sub>0</sub> through A<sub>18</sub>).

To read from the device, take Chip Enable ( $\overline{CE}_1$  LOW and  $CE_2$  HIGH) and Output Enable ( $\overline{OE}$ ) LOW while forcing the Write Enable ( $WE$ ) HIGH. If Byte Low Enable ( $\overline{BLE}$ ) is LOW, then data from the memory location specified by the address pins appear on I/O<sub>0</sub> to I/O<sub>7</sub>. If Byte High Enable ( $\overline{BHE}$ ) is LOW, then data from memory appears on I/O<sub>8</sub> to I/O<sub>15</sub>. See Truth Table on page 13 for a complete description of read and write modes.

For a complete list of related documentation, [click here](#).

## Logic Block Diagram

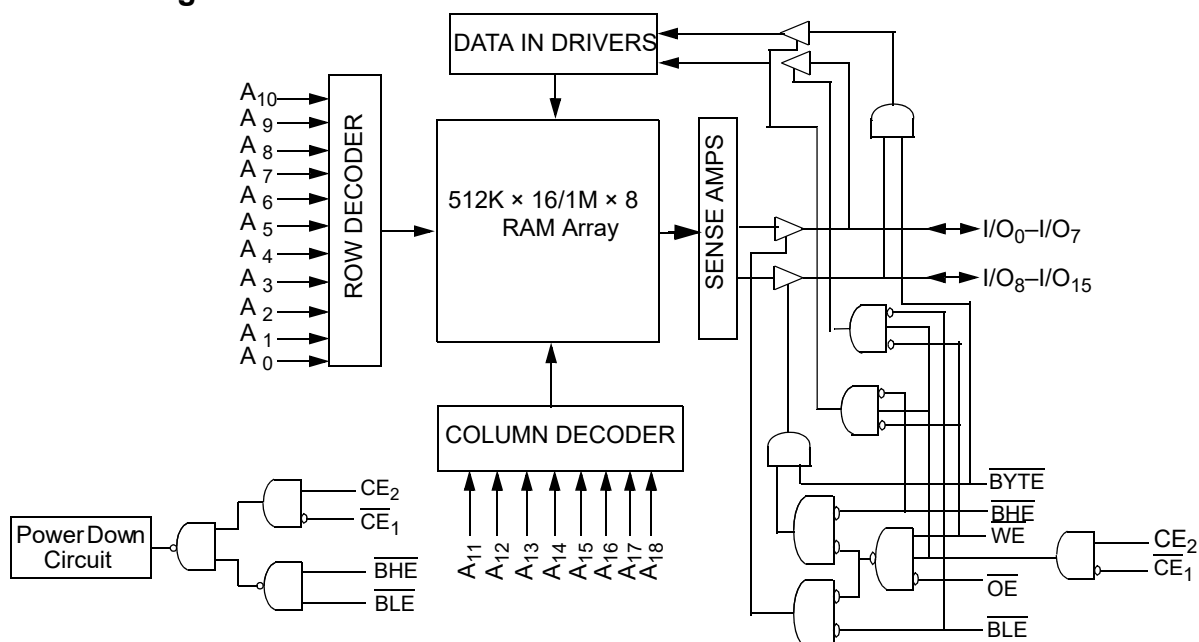

## Contents

<b>Pin Configurations</b> .....	<b>3</b>	<b>Ordering Information</b> .....	<b>14</b>
<b>Product Portfolio</b> .....	<b>3</b>	Ordering Code Definitions .....	14
<b>Maximum Ratings</b> .....	<b>4</b>	<b>Package Diagrams</b> .....	<b>15</b>
<b>Operating Range</b> .....	<b>4</b>	<b>Acronyms</b> .....	<b>18</b>
<b>Electrical Characteristics</b> .....	<b>4</b>	<b>Document Conventions</b> .....	<b>18</b>
<b>Capacitance</b> .....	<b>5</b>	Units of Measure .....	18
<b>Thermal Resistance</b> .....	<b>5</b>	<b>Document History Page</b> .....	<b>19</b>
<b>AC Test Loads and Waveforms</b> .....	<b>5</b>	<b>Sales, Solutions, and Legal Information</b> .....	<b>23</b>
<b>Data Retention Characteristics</b> .....	<b>6</b>	Worldwide Sales and Design Support .....	23
<b>Data Retention Waveform</b> .....	<b>6</b>	Products .....	23
<b>Switching Characteristics</b> .....	<b>7</b>	PSoC <sup>®</sup> Solutions .....	23
<b>Switching Waveforms</b> .....	<b>8</b>	Cypress Developer Community .....	23
<b>Truth Table</b> .....	<b>13</b>	Technical Support .....	23

## Pin Configurations

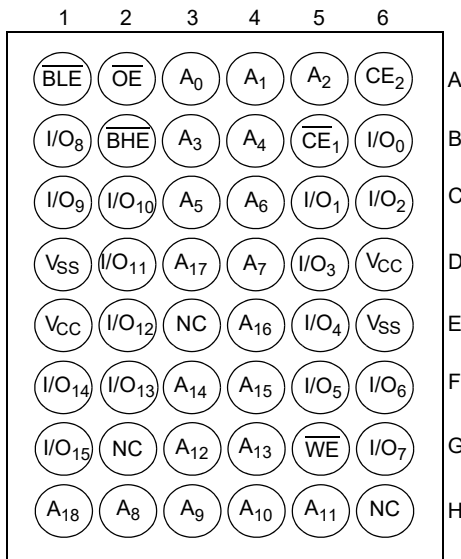
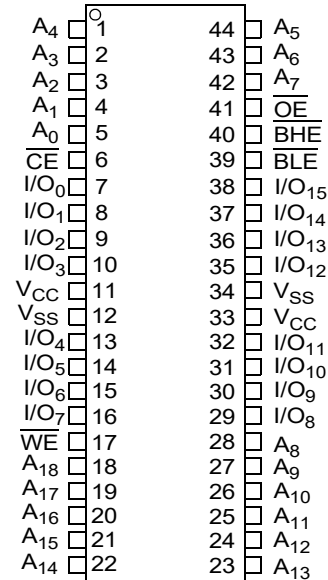
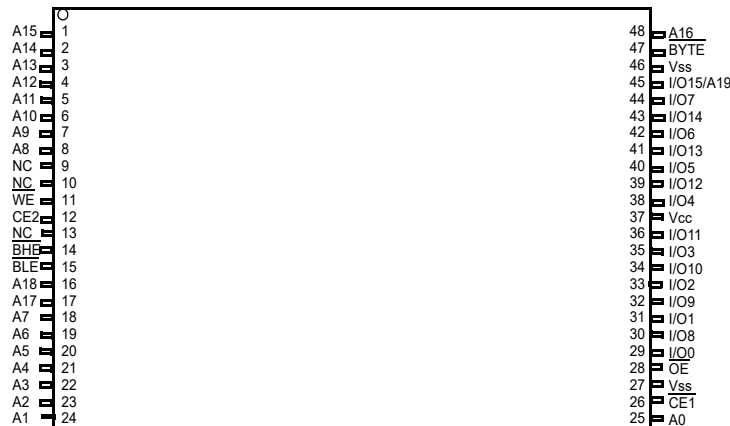
**Figure 1. 48-ball VFBGA pinout (Top View) [1]**

**Figure 2. 44-pin TSOP II pinout (Top View) [2]**

**Figure 3. 48-pin TSOP I pinout (Top View) [1, 3]**

## Product Portfolio

Product	Range	V <sub>CC</sub> Range (V)			Speed (ns)	Power Dissipation					
						Operating I <sub>CC</sub> , (mA)				Standby, I <sub>SB2</sub> (μA)	
		f = 1 MHz		f = f <sub>max</sub>							
		Min	Typ [4]	Max		Typ [4]	Max	Typ [4]	Max	Typ [4]	Max
CY62157EV30LL	Industrial/Automotive-A	2.2	3.0	3.6	45	1.8	3	18	25	2	8
	Automotive-E	2.2	3.0	3.6	55	1.8	4	18	35	2	30

### Notes

- NC pins are not connected on the die.
- The 44-pin TSOP II package has only one chip enable ( $\overline{\text{CE}}$ ) pin.
- The BYTE pin in the 48-pin TSOP I package must be tied HIGH to use the device as a 512 K × 16 SRAM. The 48-pin TSOP I package can also be used as a 1 M × 8 SRAM by tying the BYTE signal LOW. In the 1 M × 8 configuration, Pin 45 is A19, while BHE, BLE and I/O<sub>8</sub> to I/O<sub>14</sub> pins are not used.
- Typical values are included for reference only and are not guaranteed or tested. Typical values are measured at V<sub>CC</sub> = V<sub>CC(typ)</sub>, T<sub>A</sub> = 25 °C.

## Maximum Ratings

Exceeding the maximum ratings may impair the useful life of the device. User guidelines are not tested.

Storage Temperature ..... -65 °C to + 150 °C

Ambient Temperature  
with Power Applied ..... -55 °C to + 125 °C

Supply Voltage  
to Ground Potential ..... -0.3 V to 3.9 V ( $V_{CCmax} + 0.3$  V)

DC Voltage Applied to Outputs  
in High Z State <sup>[5, 6]</sup> ..... -0.3 V to 3.9 V ( $V_{CCmax} + 0.3$  V)

DC Input Voltage <sup>[5, 6]</sup> ..... -0.3 V to 3.9 V ( $V_{CCmax} + 0.3$  V)

Output Current into Outputs (LOW) ..... 20 mA

Static Discharge Voltage  
(MIL-STD-883, Method 3015) ..... > 2001 V

Latch-Up Current ..... > 200 mA

## Operating Range

Device	Range	Ambient Temperature	V <sub>CC</sub> <sup>[7]</sup>
CY62157EV30LL	Industrial / Automotive-A	-40 °C to +85 °C	2.2 V to 3.6 V
	Automotive-E	-40 °C to +125 °C	

## Electrical Characteristics

Over the Operating Range

Parameter	Description	Test Conditions	45 ns (Industrial/Automotive-A)			55 ns (Automotive-E)			Unit
			Min	Typ <sup>[8]</sup>	Max	Min	Typ <sup>[8]</sup>	Max	
V <sub>OH</sub>	Output HIGH voltage	I <sub>OH</sub> = -0.1 mA	2.0	-	-	2.0	-	-	V
		I <sub>OH</sub> = -1.0 mA, V <sub>CC</sub> ≥ 2.70 V	2.4	-	-	2.4	-	-	V
V <sub>OL</sub>	Output LOW voltage	I <sub>OL</sub> = 0.1 mA	-	-	0.4	-	-	0.4	V
		I <sub>OL</sub> = 2.1 mA, V <sub>CC</sub> ≥ 2.70 V	-	-	0.4	-	-	0.4	V
V <sub>IH</sub>	Input HIGH voltage	V <sub>CC</sub> = 2.2 V to 2.7 V	1.8	-	V <sub>CC</sub> + 0.3	1.8	-	V <sub>CC</sub> + 0.3	V
		V <sub>CC</sub> = 2.7 V to 3.6 V	2.2	-	V <sub>CC</sub> + 0.3	2.2	-	V <sub>CC</sub> + 0.3	V
V <sub>IL</sub>	Input LOW voltage	V <sub>CC</sub> = 2.2 V to 2.7 V	-0.3	-	0.6	-0.3	-	0.6	V
		V <sub>CC</sub> = 2.7 V to 3.6 V	-0.3	-	0.8	-0.3	-	0.8	V
I <sub>IX</sub>	Input leakage current	GND ≤ V <sub>I</sub> ≤ V <sub>CC</sub>	-1	-	+1	-4	-	+4	μA
I <sub>OZ</sub>	Output leakage current	GND ≤ V <sub>O</sub> ≤ V <sub>CC</sub> , Output Disabled	-1	-	+1	-4	-	+4	μA
I <sub>CC</sub>	V <sub>CC</sub> operating supply current	f = f <sub>max</sub> = 1/t <sub>RC</sub> V <sub>CC</sub> = V <sub>CCmax</sub>	-	18	25	-	18	35	mA
		f = 1 MHz    I <sub>OUT</sub> = 0 mA CMOS levels	-	1.8	3	-	1.8	4	
I <sub>SB1</sub> <sup>[9]</sup>	Automatic CE power down current – CMOS inputs	$\overline{CE}_1 \geq V_{CC} - 0.2$ V or $CE_2 \leq 0.2$ V or $(\overline{BHE}$ and $\overline{BLE}) \geq V_{CC} - 0.2$ V, $V_{IN} \geq V_{CC} - 0.2$ V, $V_{IN} \leq 0.2$ V f = f <sub>max</sub> (Address and Data Only), f = 0 ( $\overline{OE}$ and $\overline{WE}$ ), V <sub>CC</sub> = 3.60 V	-	2	8	-	2	30	μA
I <sub>SB2</sub> <sup>[9]</sup>	Automatic CE power down current – CMOS inputs	$\overline{CE}_1 \geq V_{CC} - 0.2$ V or $CE_2 \leq 0.2$ V or $(\overline{BHE}$ and $\overline{BLE}) \geq V_{CC} - 0.2$ V, $V_{IN} \geq V_{CC} - 0.2$ V or $V_{IN} \leq 0.2$ V, f = 0, V <sub>CC</sub> = 3.60 V	-	2	8	-	2	30	μA

### Notes

- V<sub>IL(min)</sub> = -2.0 V for pulse durations less than 20 ns.
- V<sub>IH(max)</sub> = V<sub>CC</sub> + 0.75 V for pulse durations less than 20 ns.
- Full device AC operation assumes a 100 μs ramp time from 0 to V<sub>CC(min)</sub> and 200 μs wait time after V<sub>CC</sub> stabilization.
- Typical values are included for reference only and are not guaranteed or tested. Typical values are measured at V<sub>CC</sub> = V<sub>CC(typ)</sub>, T<sub>A</sub> = 25 °C.
- Chip enables (CE<sub>1</sub> and CE<sub>2</sub>), byte enables (BHE and BLE) and BYTE (48-pin TSOP I only) need to be tied to CMOS levels to meet the I<sub>SB1</sub> / I<sub>SB2</sub> / I<sub>CCDR</sub> spec. Other inputs can be left floating.

### Capacitance

Parameter <sup>[10]</sup>	Description	Test Conditions	Max	Unit
C <sub>IN</sub>	Input capacitance	T <sub>A</sub> = 25 °C, f = 1 MHz, V <sub>CC</sub> = V <sub>CC(typ)</sub>	10	pF
C <sub>OUT</sub>	Output capacitance		10	pF

### Thermal Resistance

Parameter <sup>[10]</sup>	Description	Test Conditions	48-ball BGA	48-pin TSOP I	44-pin TSOP II	Unit
Θ <sub>JA</sub>	Thermal resistance (junction to ambient)	Still air, soldered on a 3 × 4.5 inch, four-layer printed circuit board	48.34	55.47	55.84	°C/W
Θ <sub>JC</sub>	Thermal resistance (junction to case)		8.78	4.08	15.79	°C/W

### AC Test Loads and Waveforms

Figure 4. AC Test Loads and Waveforms

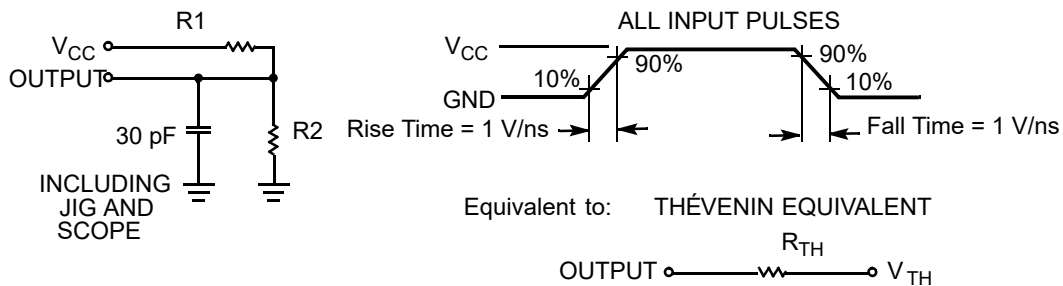

Parameters	2.5 V	3.0 V	Unit
R1	16667	1103	Ω
R2	15385	1554	Ω
R <sub>TH</sub>	8000	645	Ω
V <sub>TH</sub>	1.20	1.75	V

**Note**

10. Tested initially and after any design or process changes that may affect these parameters.

## Data Retention Characteristics

Over the Operating Range

Parameter	Description	Conditions	Min	Typ <sup>[11]</sup>	Max	Unit
$V_{DR}$	$V_{CC}$ for data retention		1.5	–	–	V
$I_{CCDR}$ <sup>[12]</sup>	Data retention current	$V_{CC} = 1.5\text{ V}$ , $\overline{CE}_1 \geq V_{CC} - 0.2\text{ V}$ , $CE_2 \leq 0.2\text{ V}$ , $(\overline{BHE}\text{ and } \overline{BLE}) \geq V_{CC} - 0.2\text{ V}$ , $V_{IN} \geq V_{CC} - 0.2\text{ V}$ or $V_{IN} \leq 0.2\text{ V}$	–	2	5	$\mu\text{A}$
			–	–	30	
$t_{CDR}$ <sup>[13]</sup>	Chip deselect to data retention time		0	–	–	ns
$t_R$ <sup>[14]</sup>	Operation recovery time	CY62157EV30LL-45	45	–	–	ns
		CY62157EV30LL-55	55	–	–	

## Data Retention Waveform

Figure 5. Data Retention Waveform<sup>[15]</sup>

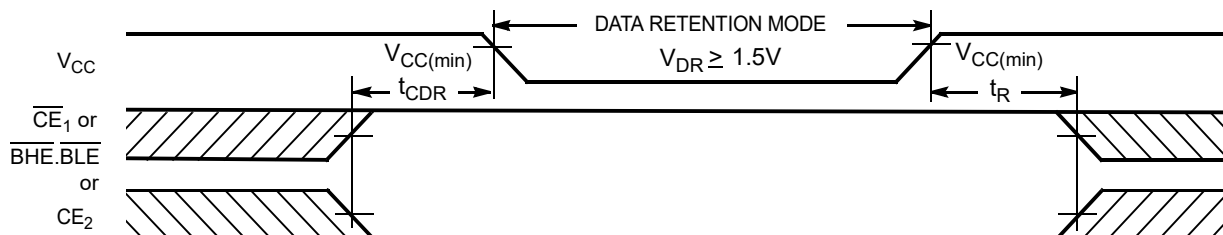

### Notes

11. Typical values are included for reference only and are not guaranteed or tested. Typical values are measured at  $V_{CC} = V_{CC(\text{typ})}$ ,  $T_A = 25\text{ }^\circ\text{C}$ .
12. Chip enables ( $\overline{CE}_1$  and  $CE_2$ ), byte enables (BHE and BLE) and BYTE (48-pin TSOP I only) need to be tied to CMOS levels to meet the  $I_{SB1}$  /  $I_{SB2}$  /  $I_{CCDR}$  spec. Other inputs can be left floating.
13. Tested initially and after any design or process changes that may affect these parameters.
14. Full device operation requires linear  $V_{CC}$  ramp from  $V_{DR}$  to  $V_{CC(\text{min})} \geq 100\text{ }\mu\text{s}$  or stable at  $V_{CC(\text{min})} \geq 100\text{ }\mu\text{s}$ .
15. BHE.BLE is the AND of both BHE and BLE. Deselect the chip by either disabling chip enable signals or by disabling both  $\overline{BHE}$  and  $\overline{BLE}$ .

## Switching Characteristics

Over the Operating Range

Parameter <sup>[16, 17]</sup>	Description	45 ns (Industrial/ Automotive-A)		55 ns (Automotive-E)		Unit
		Min	Max	Min	Max	
<b>Read Cycle</b>						
$t_{RC}$	Read cycle time	45	–	55	–	ns
$t_{AA}$	Address to data valid	–	45	–	55	ns
$t_{OHA}$	Data hold from address change	10	–	10	–	ns
$t_{ACE}$	$\overline{CE}_1$ LOW and $CE_2$ HIGH to data valid	–	45	–	55	ns
$t_{DOE}$	$\overline{OE}$ LOW to data valid	–	22	–	25	ns
$t_{LZOE}$	$\overline{OE}$ LOW to Low Z <sup>[18]</sup>	5	–	5	–	ns
$t_{HZOE}$	$\overline{OE}$ HIGH to High Z <sup>[18, 19]</sup>	–	18	–	20	ns
$t_{LZCE}$	$\overline{CE}_1$ LOW and $CE_2$ HIGH to Low Z <sup>[18]</sup>	10	–	10	–	ns
$t_{HZCE}$	$\overline{CE}_1$ HIGH and $CE_2$ LOW to High Z <sup>[18, 19]</sup>	–	18	–	20	ns
$t_{PU}$	$\overline{CE}_1$ LOW and $CE_2$ HIGH to power up	0	–	0	–	ns
$t_{PD}$	$\overline{CE}_1$ HIGH and $CE_2$ LOW to power down	–	45	–	55	ns
$t_{DBE}$	$\overline{BLE}/\overline{BHE}$ LOW to data valid	–	45	–	55	ns
$t_{LZBE}$	$\overline{BLE}/\overline{BHE}$ LOW to Low Z <sup>[18, 20]</sup>	5	–	10	–	ns
$t_{HZBE}$	$\overline{BLE}/\overline{BHE}$ HIGH to High Z <sup>[18, 19]</sup>	–	18	–	20	ns
<b>Write Cycle <sup>[21, 22]</sup></b>						
$t_{WC}$	Write cycle time	45	–	55	–	ns
$t_{SCE}$	$\overline{CE}_1$ LOW and $CE_2$ HIGH to write end	35	–	40	–	ns
$t_{AW}$	Address setup to write end	35	–	40	–	ns
$t_{HA}$	Address hold from write end	0	–	0	–	ns
$t_{SA}$	Address setup to write start	0	–	0	–	ns
$t_{PWE}$	$\overline{WE}$ pulse width	35	–	40	–	ns
$t_{BW}$	$\overline{BLE}/\overline{BHE}$ LOW to write end	35	–	40	–	ns
$t_{SD}$	Data setup to write end	25	–	25	–	ns
$t_{HD}$	Data hold from write end	0	–	0	–	ns
$t_{HZWE}$	$\overline{WE}$ LOW to High Z <sup>[18, 19]</sup>	–	18	–	20	ns
$t_{LZWE}$	$\overline{WE}$ HIGH to Low Z <sup>[18]</sup>	10	–	10	–	ns

### Notes

16. Test conditions for all parameters other than tri-state parameters assume signal transition time of 3 ns or less, timing reference levels of  $V_{CC(typ)}/2$ , input pulse levels of 0 to  $V_{CC(typ)}$ , and output loading of the specified  $I_{OL}/I_{OH}$  as shown in the [Figure 4 on page 5](#).
17. In an earlier revision of this device, under a specific application condition, READ and WRITE operations were limited to switching of the byte enable and/or chip enable signals as described in the Application Notes [AN13842](#) and [AN66311](#). However, the issue has been fixed and in production now, and hence, these Application Notes are no longer applicable. They are available for download on our website as they contain information on the date code of the parts, beyond which the fix has been in production.
18. At any temperature and voltage condition,  $t_{HZCE}$  is less than  $t_{LZCE}$ ,  $t_{HZBE}$  is less than  $t_{LZBE}$ ,  $t_{HZOE}$  is less than  $t_{LZOE}$ , and  $t_{HZWE}$  is less than  $t_{LZWE}$  for any device.
19.  $t_{HZOE}$ ,  $t_{HZCE}$ ,  $t_{HZBE}$ , and  $t_{HZWE}$  transitions are measured when the outputs enter a high-impedance state.
20. If both byte enables are toggled together, this value is 10 ns.
21. The internal write time of the memory is defined by the overlap of  $\overline{WE}$ ,  $\overline{CE} = V_{IL}$ ,  $\overline{BHE}$ ,  $\overline{BLE}$  or both =  $V_{IL}$ , and  $CE_2 = V_{IH}$ . All signals must be active to initiate a write and any of these signals can terminate a write by going inactive. The data input setup and hold timing must be referenced to the edge of the signal that terminates the write.
22. The minimum write cycle time for Write Cycle No. 3 ( $\overline{WE}$  Controlled,  $\overline{OE}$  LOW) should be equal to the sum of  $t_{SD}$  and  $t_{HZWE}$ .

## Switching Waveforms

Figure 6. Read Cycle No. 1 (Address Transition Controlled) [23, 24]

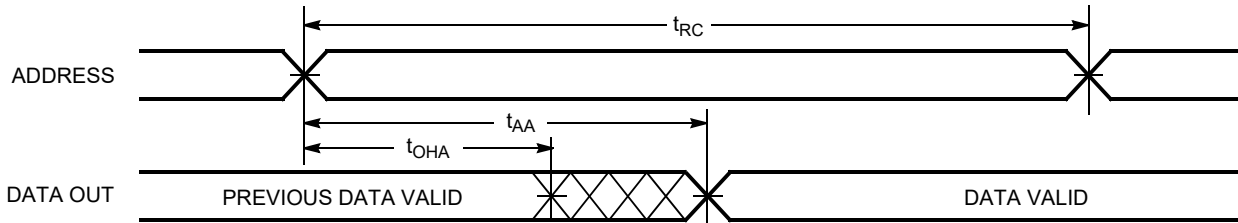
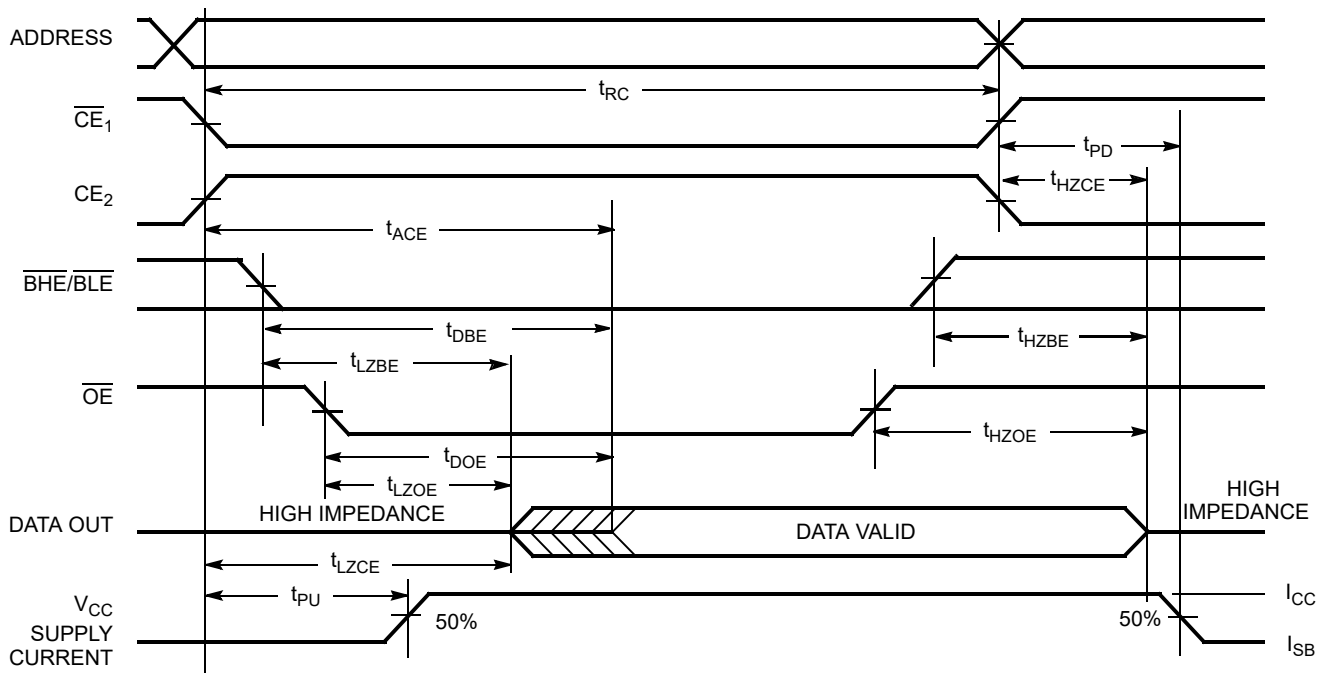

Figure 7. Read Cycle No. 2 ( $\overline{OE}$  Controlled) [24, 25]



### Notes

- 23. The device is continuously selected.  $\overline{OE}$ ,  $\overline{CE}_1 = V_{IL}$ ,  $\overline{BHE}$ ,  $\overline{BLE}$ , or both =  $V_{IL}$ , and  $CE_2 = V_{IH}$ .
- 24. WE is HIGH for read cycle.
- 25. Address valid before or similar to  $\overline{CE}_1$ ,  $\overline{BHE}$ ,  $\overline{BLE}$  transition LOW and  $CE_2$  transition HIGH.

Switching Waveforms (continued)

Figure 8. Write Cycle No. 1 ( $\overline{WE}$  Controlled) [26, 27, 28]

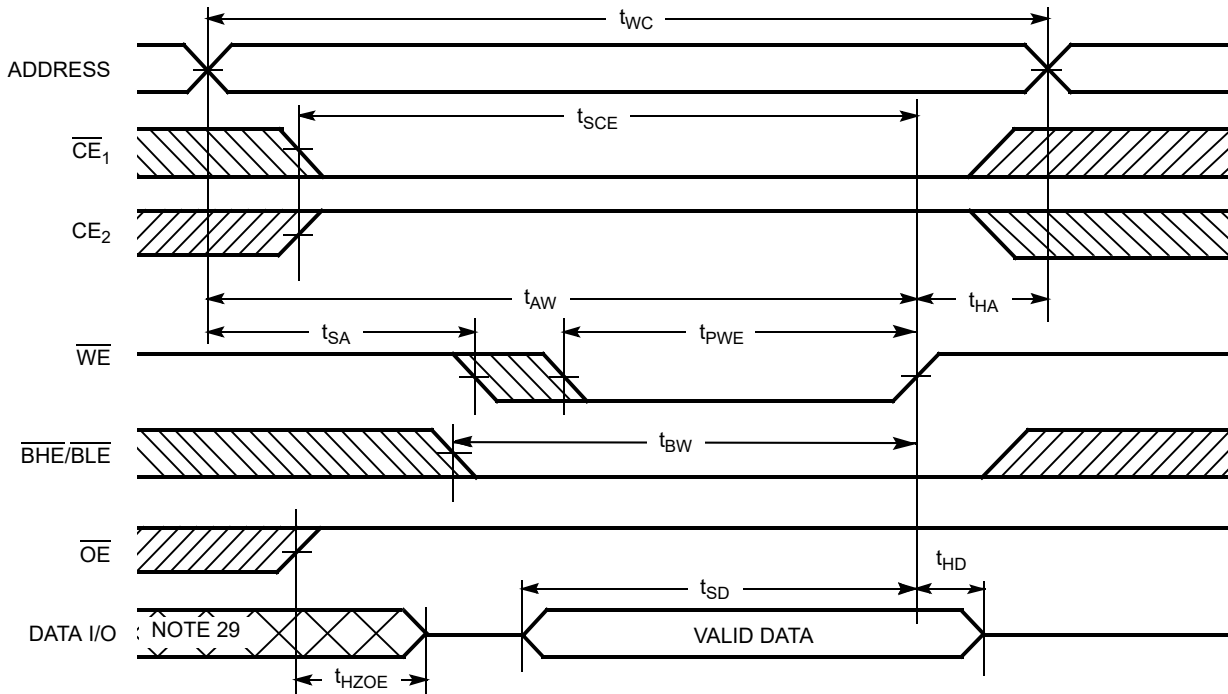

Notes

26. The internal write time of the memory is defined by the overlap of  $\overline{WE}$ ,  $\overline{CE} = V_{IL}$ ,  $\overline{BHE}$ ,  $\overline{BLE}$  or both =  $V_{IL}$ , and  $\overline{CE}_2 = V_{IH}$ . All signals must be active to initiate a write and any of these signals can terminate a write by going inactive. The data input setup and hold timing must be referenced to the edge of the signal that terminates the write.

27. Data I/O is high impedance if  $\overline{OE} = V_{IH}$ .

28. If  $\overline{CE}_1$  goes HIGH and  $\overline{CE}_2$  goes LOW simultaneously with  $\overline{WE} = V_{IH}$ , the output remains in a high impedance state.

29. During this period, the I/Os are in output state. Do not apply input signals.

Switching Waveforms (continued)

Figure 9. Write Cycle No. 2 ( $\overline{CE}_1$  or  $CE_2$  Controlled) [30, 31, 32]

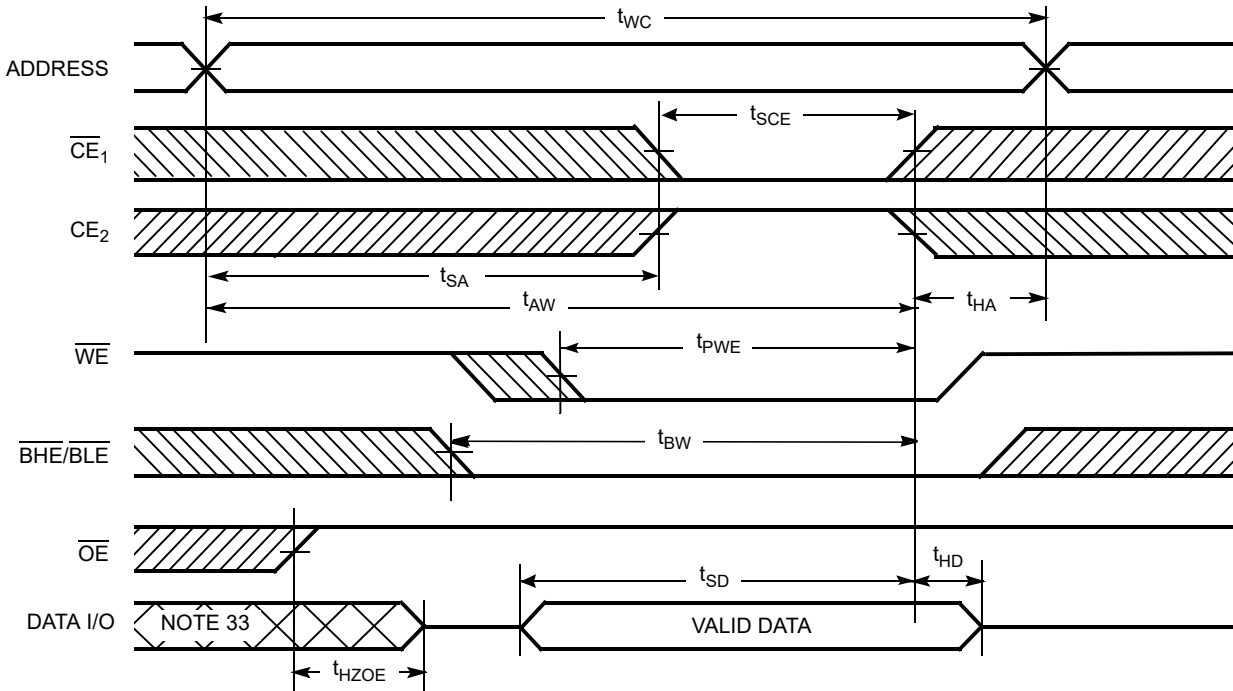

Notes

- 30. The internal write time of the memory is defined by the overlap of  $\overline{WE}$ ,  $\overline{CE} = V_{IL}$ ,  $\overline{BHE}$ ,  $\overline{BLE}$  or both =  $V_{IL}$ , and  $CE_2 = V_{IH}$ . All signals must be active to initiate a write and any of these signals can terminate a write by going inactive. The data input setup and hold timing must be referenced to the edge of the signal that terminates the write.
- 31. Data I/O is high impedance if  $\overline{OE} = V_{IH}$ .
- 32. If  $\overline{CE}_1$  goes HIGH and  $CE_2$  goes LOW simultaneously with  $\overline{WE} = V_{IH}$ , the output remains in a high impedance state.
- 33. During this period, the I/Os are in output state. Do not apply input signals.

Switching Waveforms (continued)

Figure 10. Write Cycle No. 3 ( $\overline{WE}$  Controlled,  $\overline{OE}$  LOW) [34, 35]

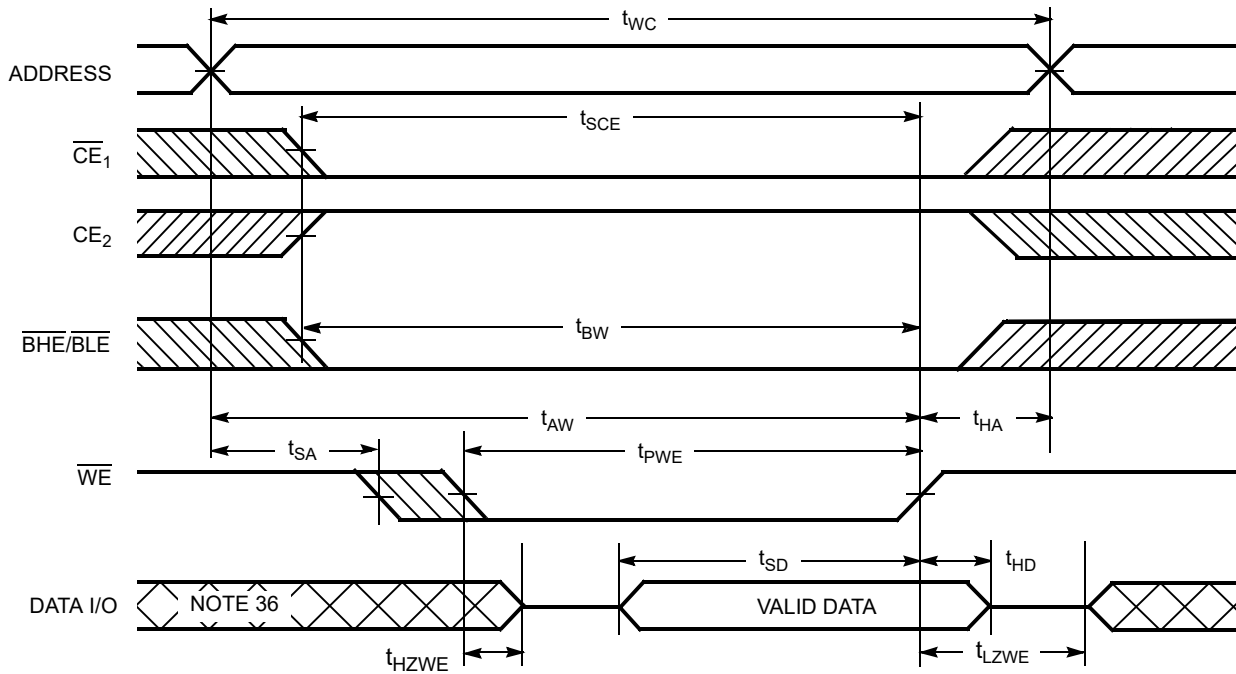

Notes

- 34. If  $\overline{CE}_1$  goes HIGH and  $CE_2$  goes LOW simultaneously with  $\overline{WE} = V_{IH}$ , the output remains in a high impedance state.
- 35. The minimum write cycle pulse width should be equal to the sum of  $t_{SD}$  and  $t_{HZWE}$ .
- 36. During this period, the I/Os are in output state. Do not apply input signals.

Switching Waveforms (continued)

Figure 11. Write Cycle No. 4 ( $\overline{\text{BHE}}/\overline{\text{BLE}}$  Controlled,  $\overline{\text{OE}}$  LOW) [37]

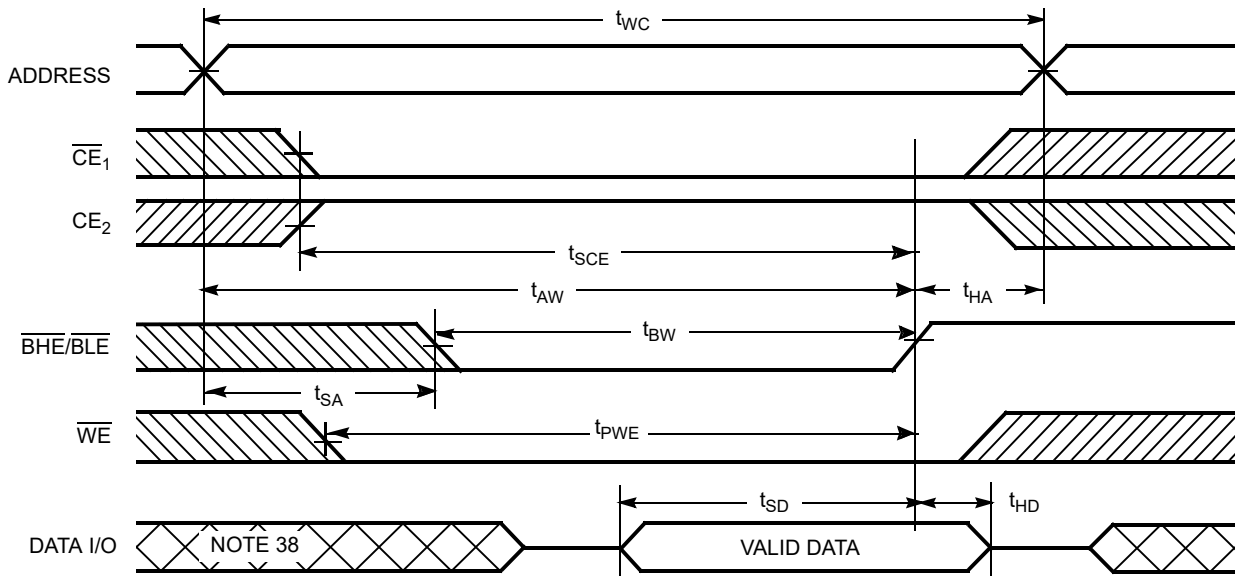

Notes

- 37. If  $\overline{\text{CE}}_1$  goes HIGH and  $\text{CE}_2$  goes LOW simultaneously with  $\overline{\text{WE}} = V_{IH}$ , the output remains in a high impedance state.
- 38. During this period, the I/Os are in output state. Do not apply input signals.

**Truth Table**

$\overline{CE}_1$	$CE_2$	$\overline{WE}$	$\overline{OE}$	$\overline{BHE}$	$\overline{BLE}$	Inputs/Outputs	Mode	Power
H	X <sup>[39]</sup>	X	X	X	X	High Z	Deselect/power down	Standby ( $I_{SB}$ )
X <sup>[39]</sup>	L	X	X	X	X	High Z	Deselect/power down	Standby ( $I_{SB}$ )
X <sup>[39]</sup>	X <sup>[39]</sup>	X	X	H	H	High Z	Deselect/power down	Standby ( $I_{SB}$ )
L	H	H	L	L	L	Data Out ( $I/O_0$ – $I/O_{15}$ )	Read	Active ( $I_{CC}$ )
L	H	H	L	H	L	Data Out ( $I/O_0$ – $I/O_7$ ); High Z ( $I/O_8$ – $I/O_{15}$ )	Read	Active ( $I_{CC}$ )
L	H	H	L	L	H	High Z ( $I/O_0$ – $I/O_7$ ); Data Out ( $I/O_8$ – $I/O_{15}$ )	Read	Active ( $I_{CC}$ )
L	H	H	H	L	H	High Z	Output disabled	Active ( $I_{CC}$ )
L	H	H	H	H	L	High Z	Output disabled	Active ( $I_{CC}$ )
L	H	H	H	L	L	High Z	Output disabled	Active ( $I_{CC}$ )
L	H	L	X	L	L	Data In ( $I/O_0$ – $I/O_{15}$ )	Write	Active ( $I_{CC}$ )
L	H	L	X	H	L	Data In ( $I/O_0$ – $I/O_7$ ); High Z ( $I/O_8$ – $I/O_{15}$ )	Write	Active ( $I_{CC}$ )
L	H	L	X	L	H	High Z ( $I/O_0$ – $I/O_7$ ); Data In ( $I/O_8$ – $I/O_{15}$ )	Write	Active ( $I_{CC}$ )

**Note**

39. The 'X' (Don't care) state for the Chip enables in the truth table refer to the logic state (either HIGH or LOW). Intermediate voltage levels on these pins is not permitted.

### Ordering Information

Speed (ns)	Ordering Code	Package Diagram	Package Type	Operating Range
45	CY62157EV30LL-45BVI	51-85150	48-ball VFBGA	Industrial
	CY62157EV30LL-45BVIT	51-85150	48-ball VFBGA	
	CY62157EV30LL-45BVXI	51-85150	48-ball VFBGA (Pb-free)	
	CY62157EV30LL-45BVXIT	51-85150	48-ball VFBGA (Pb-free)	
	CY62157EV30LL-45ZSXI	51-85087	44-pin TSOP Type II (Pb-free)	
	CY62157EV30LL-45ZSXIT	51-85087	44-pin TSOP Type II (Pb-free)	
	CY62157EV30LL-45ZXI	51-85183	48-pin TSOP Type I (Pb-free)	
	CY62157EV30LL-45ZXIT	51-85183	48-pin TSOP Type I (Pb-free)	
	Automotive-A	CY62157EV30LL-45BVXA	51-85150	48-ball VFBGA (Pb-free)
		CY62157EV30LL-45BVXAT	51-85150	48-ball VFBGA (Pb-free)
		CY62157EV30LL-45ZSXA	51-85087	44-pin TSOP Type II (Pb-free)
		CY62157EV30LL-45ZSXAT	51-85087	44-pin TSOP Type II (Pb-free)
		CY62157EV30LL-45ZXA	51-85183	48-pin TSOP Type I (Pb-free)
		CY62157EV30LL-45ZXAT	51-85183	48-pin TSOP Type I (Pb-free)
55	CY62157EV30LL-55ZSXE	51-85087	44-pin TSOP Type II (Pb-free)	Automotive-E
	CY62157EV30LL-55ZSXET	51-85087	44-pin TSOP Type II (Pb-free)	
	CY62157EV30LL-55ZXE	51-85183	48-pin TSOP Type I (Pb-free)	
	CY62157EV30LL-55ZXET	51-85183	48-pin TSOP Type I (Pb-free)	

Contact your local Cypress sales representative for availability of these parts.

### Ordering Code Definitions

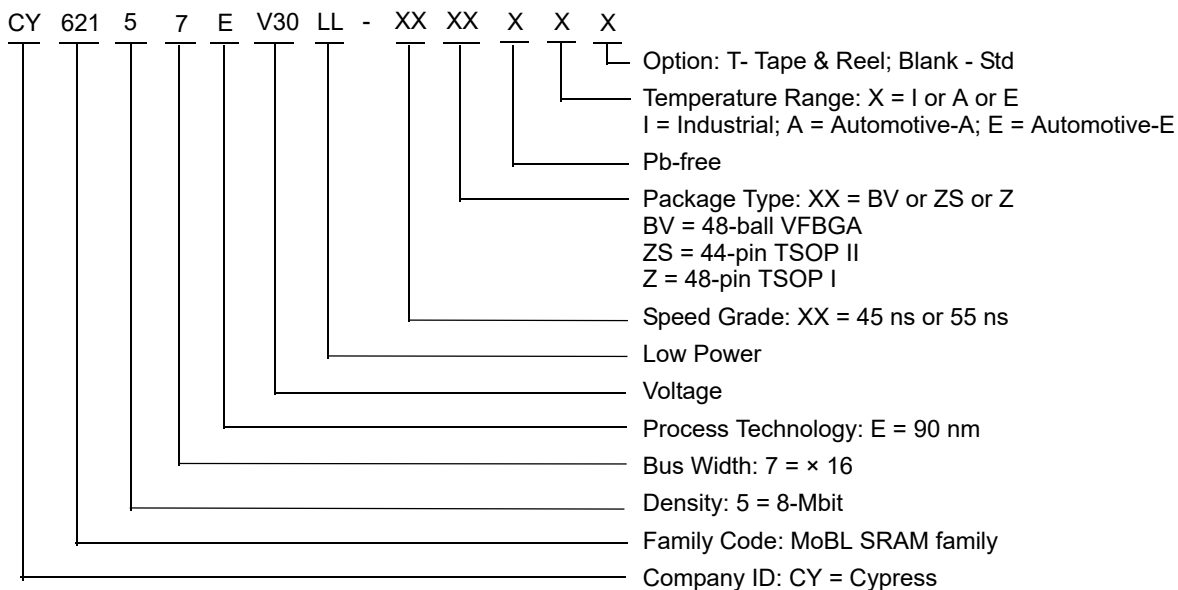

## Package Diagrams

Figure 12. 48-pin VFBGA (6 × 8 × 1.0 mm) Package Outline, 51-85150

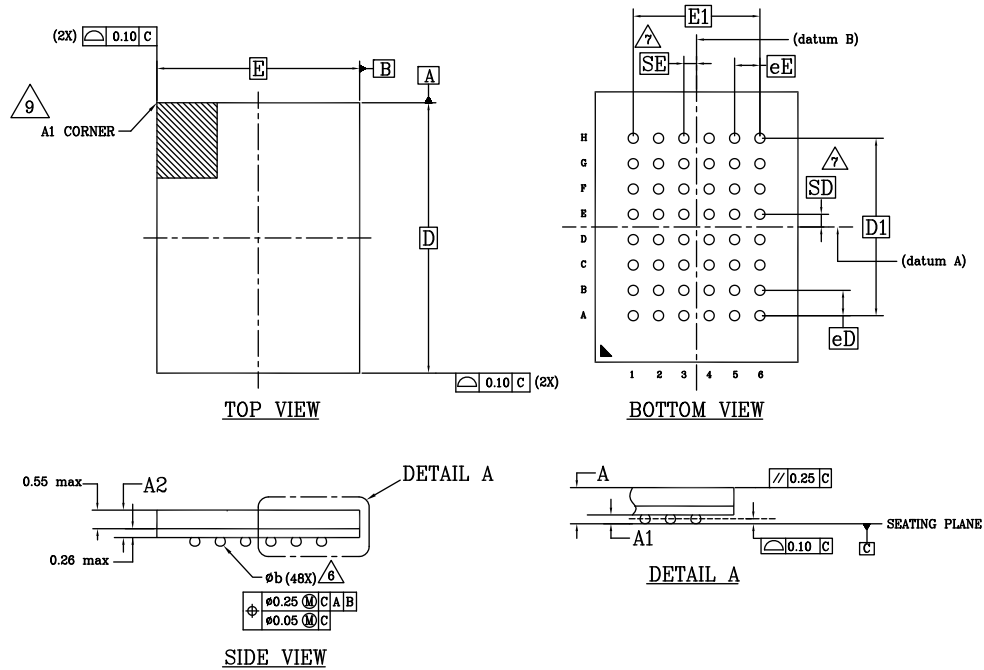

SYMBOL	DIMENSIONS		
	MIN.	NOM.	MAX.
A	-	-	1.00
A1	0.16	-	-
A2	-	-	0.81
D	8.00 BSC		
E	6.00 BSC		
D1	5.25 BSC		
E1	3.75 BSC		
MD	8		
ME	6		
n	48		
∅ b	0.25	0.30	0.35
eE	0.75 BSC		
eD	0.75 BSC		
SD	0.375 BSC		
SE	0.375 BSC		

### NOTES:

- DIMENSIONING AND TOLERANCING METHODS PER ASME Y14.5M-2009.
- ALL DIMENSIONS ARE IN MILLIMETERS.
- BALL POSITION DESIGNATION PER JEP95, SECTION 3, SPP-020.
- $\square$  REPRESENTS THE SOLDER BALL GRID PITCH.
- SYMBOL "MD" IS THE BALL MATRIX SIZE IN THE "D" DIRECTION, SYMBOL "ME" IS THE BALL MATRIX SIZE IN THE "E" DIRECTION, n IS THE NUMBER OF POPULATED SOLDER BALL POSITIONS FOR MATRIX SIZE MD X ME.
- $\triangle$  DIMENSION "b" IS MEASURED AT THE MAXIMUM BALL DIAMETER IN A PLANE PARALLEL TO DATUM C.
- $\triangle$  "SD" AND "SE" ARE MEASURED WITH RESPECT TO DATUMS A AND B AND DEFINE THE POSITION OF THE CENTER SOLDER BALL IN THE OUTER ROW. WHEN THERE IS AN ODD NUMBER OF SOLDER BALLS IN THE OUTER ROW "SD" OR "SE" = 0. WHEN THERE IS AN EVEN NUMBER OF SOLDER BALLS IN THE OUTER ROW, "SD" = eD/2 AND "SE" = eE/2.
- \*-\* INDICATES THE THEORETICAL CENTER OF DEPOPULATED BALLS.
- $\triangle$  A1 CORNER TO BE IDENTIFIED BY CHAMFER, LASER OR INK MARK METALIZED MARK, INDENTATION OR OTHER MEANS.

51-85150 \*1

Package Diagrams (continued)

Figure 13. 44-pin TSOP II Package Outline, 51-85087

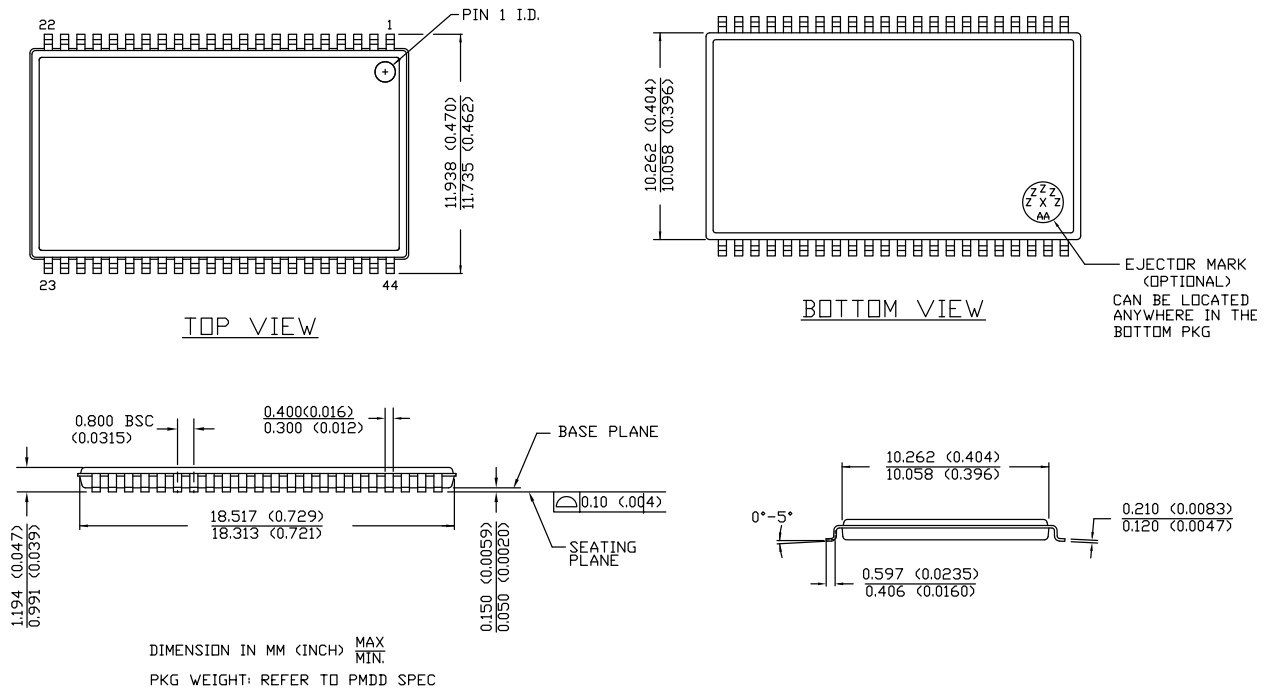

51-85087 \*E

Package Diagrams (continued)

Figure 14. 48-pin TSOP I (18.4 × 12 × 1.2 mm) Package Outline, 51-85183

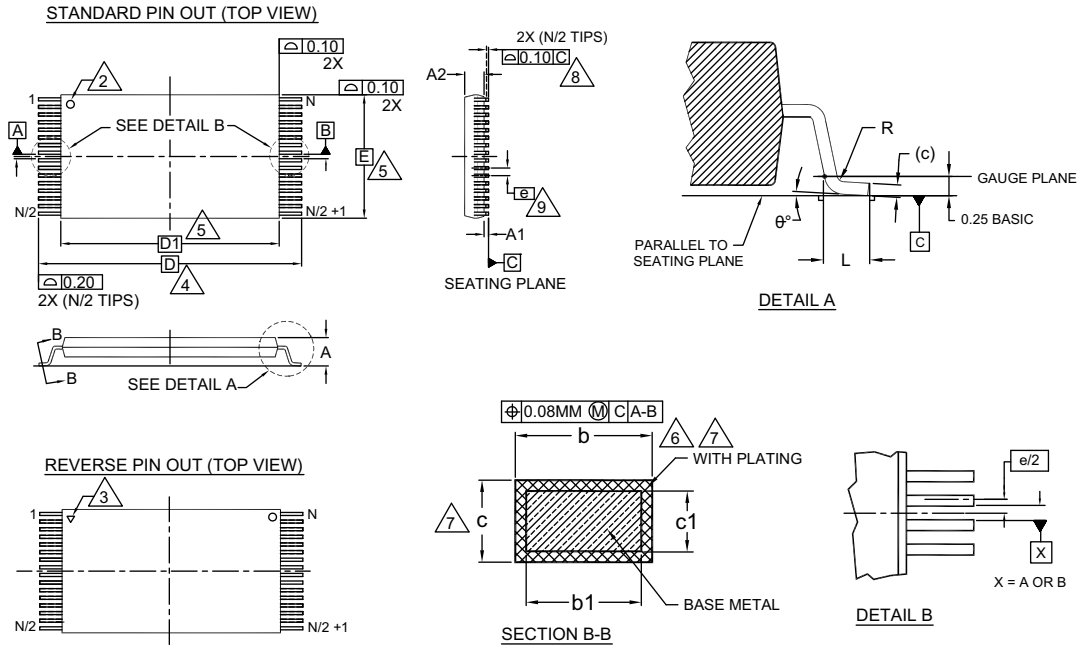

SYMBOL	DIMENSIONS		
	MIN.	NOM.	MAX.
A	—	—	1.20
A1	0.05	—	0.15
A2	0.95	1.00	1.05
b1	0.17	0.20	0.23
b	0.17	0.22	0.27
c1	0.10	—	0.16
c	0.10	—	0.21
D	20.00 BASIC		
D1	18.40 BASIC		
E	12.00 BASIC		
e	0.50 BASIC		
L	0.50	0.60	0.70
theta	0°	—	8
R	0.08	—	0.20
N	48		

NOTES:

1. DIMENSIONS ARE IN MILLIMETERS (mm).
2. PIN 1 IDENTIFIER FOR STANDARD PIN OUT (DIE UP).
3. PIN 1 IDENTIFIER FOR REVERSE PIN OUT (DIE DOWN): INK OR LASER MARK.
4. TO BE DETERMINED AT THE SEATING PLANE [C-]. THE SEATING PLANE IS DEFINED AS THE PLANE OF CONTACT THAT IS MADE WHEN THE PACKAGE LEADS ARE ALLOWED TO REST FREELY ON A FLAT HORIZONTAL SURFACE.
5. DIMENSIONS D1 AND E DO NOT INCLUDE MOLD PROTRUSION. ALLOWABLE MOLD PROTRUSION ON E IS 0.15mm PER SIDE AND ON D1 IS 0.25mm PER SIDE.
6. DIMENSION b DOES NOT INCLUDE DAMBAR PROTRUSION. ALLOWABLE DAMBAR PROTRUSION SHALL BE 0.08mm TOTAL IN EXCESS OF b DIMENSION AT MAX. MATERIAL CONDITION. DAMBAR CANNOT BE LOCATED ON LOWER RADIUS OR THE FOOT. MINIMUM SPACE BETWEEN PROTRUSION AND AN ADJACENT LEAD TO BE 0.07mm.
7. THESE DIMENSIONS APPLY TO THE FLAT SECTION OF THE LEAD BETWEEN 0.10mm AND 0.25mm FROM THE LEAD TIP.
8. LEAD COPLANARITY SHALL BE WITHIN 0.10mm AS MEASURED FROM THE SEATING PLANE.
9. DIMENSION "e" IS MEASURED AT THE CENTERLINE OF THE LEADS.
10. JEDEC SPECIFICATION NO. REF: MO-142(D)DD.

51-85183 \*F

## Acronyms

Acronym	Description
$\overline{CE}$	Chip Enable
CMOS	Complementary Metal Oxide Semiconductor
I/O	Input/Output
$\overline{OE}$	Output Enable
RAM	Random Access Memory
SRAM	Static Random Access Memory
TSOP	Thin Small Outline Package
VFBGA	Very Fine-Pitch Ball Grid Array
$\overline{WE}$	Write Enable

## Document Conventions

### Units of Measure

Symbol	Unit of Measure
°C	degree Celsius
MHz	megahertz
μA	microampere
μs	microsecond
mA	milliampere
mm	millimeter
ns	nanosecond
Ω	ohm
%	percent
pF	picofarad
V	volt
W	watt

**Document History Page**

Document Title: CY62157EV30 MoBL <sup>®</sup> , 8-Mbit (512K × 16) Static RAM Document Number: 38-05445				
Revision	ECN	Orig. of Change	Submission Date	Description of Change
**	202940	AJU	01/29/2004	New data sheet.
*A	291272	SYT	11/19/2004	<p>Changed status from Advance Information to Preliminary.            Removed 48-pin TSOP I Package related information in all instances across the document.            Updated <a href="#">Pin Configurations</a>:            Added Note 2 and referred the same note in <a href="#">Figure 2</a>.            Updated <a href="#">Operating Range</a>:            Updated Note 7 (Replaced 100 μs with 200 μs).            Updated <a href="#">Data Retention Characteristics</a>:            Changed maximum value of I<sub>CCDR</sub> parameter from 4 μA to 4.5 μA.            Updated <a href="#">Switching Characteristics</a>:            Changed minimum value of t<sub>OHA</sub> parameter from 6 ns to 10 ns corresponding to both 35 and 45 ns speed bins.            Changed maximum value of t<sub>DOE</sub> parameter from 15 ns to 18 ns corresponding to 35 ns speed bin.            Changed maximum value of t<sub>HZOE</sub> parameter from 12 ns to 15 ns corresponding to 35 ns speed bin.            Changed maximum value of t<sub>HZOE</sub> parameter from 15 ns to 18 ns corresponding to 45 ns speed bin.            Changed maximum value of t<sub>HZCE</sub> parameter from 12 ns to 18 ns corresponding to 35 ns speed bin.            Changed maximum value of t<sub>HZCE</sub> parameter from 15 ns to 22 ns corresponding to 45 ns speed bin.            Changed maximum value of t<sub>HZBE</sub> parameter from 12 ns to 15 ns corresponding to 35 ns speed bin.            Changed maximum value of t<sub>HZBE</sub> parameter from 15 ns to 18 ns corresponding to 45 ns speed bin.            Changed minimum value of t<sub>SCE</sub> parameter from 25 ns to 30 ns corresponding to 35 ns speed bin.            Changed minimum value of t<sub>SCE</sub> parameter from 40 ns to 35 ns corresponding to 45 ns speed bin.            Changed minimum value of t<sub>AW</sub> parameter from 25 ns to 30 ns corresponding to 35 ns speed bin.            Changed minimum value of t<sub>AW</sub> parameter from 40 ns to 35 ns corresponding to 45 ns speed bin.            Changed minimum value of t<sub>BW</sub> parameter from 25 ns to 30 ns corresponding to 35 ns speed bin.            Changed minimum value of t<sub>BW</sub> parameter from 40 ns to 35 ns corresponding to 45 ns speed bin.            Changed minimum value of t<sub>SD</sub> parameter from 15 ns to 18 ns corresponding to 35 ns speed bin.            Changed minimum value of t<sub>SD</sub> parameter from 20 ns to 22 ns corresponding to 45 ns speed bin.            Changed maximum value of t<sub>HZWE</sub> parameter from 12 ns to 15 ns corresponding to 35 ns speed bin.            Changed maximum value of t<sub>HZWE</sub> parameter from 15 ns to 18 ns corresponding to 45 ns speed bin.            Updated <a href="#">Ordering Information</a>:            Updated part numbers.</p>

**Document History Page** (continued)

Document Title: CY62157EV30 MoBL <sup>®</sup> , 8-Mbit (512K × 16) Static RAM Document Number: 38-05445				
Revision	ECN	Orig. of Change	Submission Date	Description of Change
*B	444306	NXR	04/13/2006	<p>Changed status from Preliminary to Final.</p> <p>Removed 35 ns speed bin related information in all instances across the document.</p> <p>Added 55 ns speed bin related information in all instances across the document.</p> <p>Added 48-pin TSOP I Package related information in all instances across the document.</p> <p>Added Automotive Temperature Range related information in all instances across the document.</p> <p>Updated <a href="#">Pin Configurations</a>:</p> <p>Updated <a href="#">Figure 1</a> (Replaced DNU with NC in ball E3).</p> <p>Removed Note "DNU pins have to be left floating or tied to V<sub>SS</sub> to ensure proper application." and its reference.</p> <p>Updated <a href="#">Product Portfolio</a>:</p> <p>Removed "L" and "LL" from the part numbers.</p> <p>Updated <a href="#">Electrical Characteristics</a>:</p> <p>Changed typical value of I<sub>CC</sub> parameter from 16 mA to 18 mA corresponding to 45 ns speed bin and Test Condition "f = fax = 1/t<sub>RC</sub>".</p> <p>Changed maximum value of I<sub>CC</sub> parameter from 28 mA to 25 mA corresponding to 45 ns speed bin and Test Condition "f = fax = 1/t<sub>RC</sub>".</p> <p>Changed maximum value of I<sub>CC</sub> parameter from 2.3 mA to 3 mA corresponding to 45 ns speed bin and Test Condition "f = 1 MHz".</p> <p>Updated details in "Test Condition" column corresponding to I<sub>SB1</sub> parameter.</p> <p>Changed typical value of I<sub>SB1</sub> parameter from 0.9 μA to 2 μA corresponding to 45 ns speed bin.</p> <p>Changed maximum value of I<sub>SB1</sub> parameter from 4.5 μA to 8 μA corresponding to 45 ns speed bin.</p> <p>Changed typical value of I<sub>SB2</sub> parameter from 0.9 μA to 2 μA corresponding to 45 ns speed bin.</p> <p>Changed maximum value of I<sub>SB2</sub> parameter from 4.5 μA to 8 μA corresponding to 45 ns speed bin.</p> <p>Updated <a href="#">Thermal Resistance</a>:</p> <p>Replaced TBD with values in TSOP II column and updated all remaining values.</p> <p>Updated <a href="#">AC Test Loads and Waveforms</a>:</p> <p>Updated <a href="#">Figure 4</a> (Replaced 50 pF with 30 pF).</p> <p>Updated <a href="#">Data Retention Characteristics</a>:</p> <p>Added value in "Typ" column for I<sub>CCDR</sub> parameter.</p> <p>Changed maximum value of I<sub>CCDR</sub> parameter from 4.5 μA to 5 μA corresponding to Test Condition "Industrial".</p> <p>Changed minimum value of t<sub>R</sub> parameter from 100 μs to t<sub>RC</sub> ns.</p>

**Document History Page** (continued)

Document Title: CY62157EV30 MoBL <sup>®</sup> , 8-Mbit (512K × 16) Static RAM Document Number: 38-05445				
Revision	ECN	Orig. of Change	Submission Date	Description of Change
*B (cont.)	444306	NXR	04/13/2006	Updated <a href="#">Switching Characteristics</a> : Changed minimum value of $t_{LZOE}$ parameter from 3 ns to 5 ns corresponding to 45 ns speed bin. Changed minimum value of $t_{LZCE}$ parameter from 6 ns to 10 ns corresponding to 45 ns speed bin. Changed maximum value of $t_{HZCE}$ parameter from 22 ns to 18 ns corresponding to 45 ns speed bin. Changed minimum value of $t_{LZBE}$ parameter from 6 ns to 5 ns corresponding to 45 ns speed bin. Changed minimum value of $t_{PWE}$ parameter from 30 ns to 35 ns corresponding to 45 ns speed bin. Changed minimum value of $t_{SD}$ parameter from 22 ns to 25 ns corresponding to 45 ns speed bin. Changed minimum value of $t_{LZWE}$ parameter from 6 ns to 10 ns corresponding to 45 ns speed bin. Added Note 20 and referred the same note in $t_{LZBE}$ parameter. Updated <a href="#">Ordering Information</a> : Updated part numbers. Removed "Package Name" column. Added "Package Diagram" column.
*C	467052	NXR	06/06/2006	Added 1M × 8 configuration related information in all instances across the document. Updated <a href="#">Ordering Information</a> : Updated part numbers.
*D	925501	VKN	04/09/2007	Removed Automotive-E temperature range related information in all instances across the document. Added Preliminary Automotive-A related information in all instances across the document. Updated <a href="#">Electrical Characteristics</a> : Added Note 9 and referred the same note in $I_{SB2}$ parameter. Updated <a href="#">Switching Characteristics</a> : Added Note 17 and referred the same note in "Parameter" column.
*E	1045801	VKN	05/08/2007	Changed Automotive-A temperature range related information from Preliminary to Final. Updated <a href="#">Electrical Characteristics</a> : Updated Note 9.
*F	2724889	NXR / AESA	06/26/2009	Added Automotive-E temperature range related information in all instances across the document. Updated <a href="#">Ordering Information</a> : Updated part numbers. Updated to new template.
*G	2927528	VKN	05/04/2010	Updated <a href="#">Pin Configurations</a> : Updated <a href="#">Figure 3</a> (Renamed "DNU" pins as "NC"). Updated <a href="#">Truth Table</a> : Added Note 39 and referred the same note in "X" in " $\overline{CE}_1$ " and " $\overline{CE}_2$ " columns. Updated <a href="#">Package Diagrams</a> : spec 51-85150 – Changed revision from *D to *E. spec 51-85087 – Changed revision from *A to *C. spec 51-85183 – Changed revision from *A to *B. Updated to new template.
*H	3110053	PRAS	12/14/2010	Changed Table Footnotes to Notes. Updated <a href="#">Ordering Information</a> : No change in part numbers. Added <a href="#">Ordering Code Definitions</a> .

**Document History Page** (continued)

Document Title: CY62157EV30 MoBL <sup>®</sup> , 8-Mbit (512K × 16) Static RAM Document Number: 38-05445				
Revision	ECN	Orig. of Change	Submission Date	Description of Change
*I	3269771	RAME	05/30/2011	Updated <a href="#">Functional Description</a> : Updated description. Updated <a href="#">Electrical Characteristics</a> : Updated details in “Conditions” column corresponding to I <sub>SB1</sub> and I <sub>SB2</sub> parameters. Updated <a href="#">Data Retention Characteristics</a> : Updated details in “Conditions” and “Min” columns corresponding to I <sub>CCDR</sub> and t <sub>R</sub> parameters. Updated <a href="#">Package Diagrams</a> : spec 51-85150 – Changed revision from *E to *F. Added <a href="#">Acronyms</a> and <a href="#">Units of Measure</a> . Updated to new template. Completing Sunset Review.
*J	3578601	TAVA	04/11/2012	Updated <a href="#">Package Diagrams</a> : spec 51-85150 – Changed revision from *F to *G. spec 51-85087 – Changed revision from *C to *D. spec 51-85183 – Changed revision from *B to *C. Completing Sunset Review.
*K	4102449	VINI	08/22/2013	Updated <a href="#">Switching Characteristics</a> : Updated Note 17. Updated <a href="#">Package Diagrams</a> : spec 51-85150 – Changed revision from *G to *H. spec 51-85087 – Changed revision from *D to *E. Updated to new template.
*L	4126231	VINI	09/18/2013	Updated <a href="#">Switching Characteristics</a> : Updated Note 17 (Removed last sentence from Note 17 and added the same sentence as a new note namely Note 18).
*M	4214977	MEMJ	12/09/2013	Updated <a href="#">Pin Configurations</a> : Updated Note 3 (Removed ‘NC’ mentioned at the end of the note).
*N	4578508	MEMJ	11/24/2014	Updated <a href="#">Functional Description</a> : Added “For a complete list of related documentation, <a href="#">click here</a> .” at the end. Updated <a href="#">Switching Characteristics</a> : Added Note 22 and referred the same note in “Write Cycle”. Updated <a href="#">Switching Waveforms</a> : Added Note 35 and referred the same note in <a href="#">Figure 10</a> .
*O	4748627	NILE	04/30/2015	Updated <a href="#">Package Diagrams</a> : spec 51-85183 – Changed revision from *C to *D. Updated to new template. Completing Sunset Review.
*P	5320972	NILE	06/23/2016	Updated <a href="#">Thermal Resistance</a> : Replaced “two-layer” with “four-layer” in “Test Conditions” column. Updated values of $\theta_{JA}$ , $\theta_{JC}$ parameters corresponding to all packages. Updated <a href="#">Ordering Information</a> : Updated part numbers. Updated to new template.
*Q	5731504	NILE	05/10/2017	Updated <a href="#">Package Diagrams</a> : spec 51-85183 – Changed revision from *D to *F. Updated to new template. Completing Sunset Review.
*R	6517814	NILE	03/21/2019	Updated <a href="#">Package Diagrams</a> : spec 51-85150 – Changed revision from *H to *I. Updated to new template.

## Sales, Solutions, and Legal Information

### Worldwide Sales and Design Support

Cypress maintains a worldwide network of offices, solution centers, manufacturer's representatives, and distributors. To find the office closest to you, visit us at [Cypress Locations](#).

#### Products

Arm® Cortex® Microcontrollers	<a href="http://cypress.com/arm">cypress.com/arm</a>
Automotive	<a href="http://cypress.com/automotive">cypress.com/automotive</a>
Clocks & Buffers	<a href="http://cypress.com/clocks">cypress.com/clocks</a>
Interface	<a href="http://cypress.com/interface">cypress.com/interface</a>
Internet of Things	<a href="http://cypress.com/iot">cypress.com/iot</a>
Memory	<a href="http://cypress.com/memory">cypress.com/memory</a>
Microcontrollers	<a href="http://cypress.com/mcu">cypress.com/mcu</a>
PSoC	<a href="http://cypress.com/psoc">cypress.com/psoc</a>
Power Management ICs	<a href="http://cypress.com/pmic">cypress.com/pmic</a>
Touch Sensing	<a href="http://cypress.com/touch">cypress.com/touch</a>
USB Controllers	<a href="http://cypress.com/usb">cypress.com/usb</a>
Wireless Connectivity	<a href="http://cypress.com/wireless">cypress.com/wireless</a>

#### PSoC® Solutions

[PSoC 1](#) | [PSoC 3](#) | [PSoC 4](#) | [PSoC 5LP](#) | [PSoC 6 MCU](#)

#### Cypress Developer Community

[Community](#) | [Projects](#) | [Video](#) | [Blogs](#) | [Training](#) | [Components](#)

#### Technical Support

[cypress.com/support](http://cypress.com/support)



© Cypress Semiconductor Corporation, 2004–2019. This document is the property of Cypress Semiconductor Corporation and its subsidiaries ("Cypress"). This document, including any software or firmware included or referenced in this document ("Software"), is owned by Cypress under the intellectual property laws and treaties of the United States and other countries worldwide. Cypress reserves all rights under such laws and treaties and does not, except as specifically stated in this paragraph, grant any license under its patents, copyrights, trademarks, or other intellectual property rights. If the Software is not accompanied by a license agreement and you do not otherwise have a written agreement with Cypress governing the use of the Software, then Cypress hereby grants you a personal, non-exclusive, nontransferable license (without the right to sublicense) (1) under its copyright rights in the Software (a) for Software provided in source code form, to modify and reproduce the Software solely for use with Cypress hardware products, only internally within your organization, and (b) to distribute the Software in binary code form externally to end users (either directly or indirectly through resellers and distributors), solely for use on Cypress hardware product units, and (2) under those claims of Cypress's patents that are infringed by the Software (as provided by Cypress, unmodified) to make, use, distribute, and import the Software solely for use with Cypress hardware products. Any other use, reproduction, modification, translation, or compilation of the Software is prohibited.

TO THE EXTENT PERMITTED BY APPLICABLE LAW, CYPRESS MAKES NO WARRANTY OF ANY KIND, EXPRESS OR IMPLIED, WITH REGARD TO THIS DOCUMENT OR ANY SOFTWARE OR ACCOMPANYING HARDWARE, INCLUDING, BUT NOT LIMITED TO, THE IMPLIED WARRANTIES OF MERCHANTABILITY AND FITNESS FOR A PARTICULAR PURPOSE. No computing device can be absolutely secure. Therefore, despite security measures implemented in Cypress hardware or software products, Cypress shall have no liability arising out of any security breach, such as unauthorized access to or use of a Cypress product. CYPRESS DOES NOT REPRESENT, WARRANT, OR GUARANTEE THAT CYPRESS PRODUCTS, OR SYSTEMS CREATED USING CYPRESS PRODUCTS, WILL BE FREE FROM CORRUPTION, ATTACK, VIRUSES, INTERFERENCE, HACKING, DATA LOSS OR THEFT, OR OTHER SECURITY INTRUSION (collectively, "Security Breach"). Cypress disclaims any liability relating to any Security Breach, and you shall and hereby do release Cypress from any claim, damage, or other liability arising from any Security Breach. In addition, the products described in these materials may contain design defects or errors known as errata which may cause the product to deviate from published specifications. To the extent permitted by applicable law, Cypress reserves the right to make changes to this document without further notice. Cypress does not assume any liability arising out of the application or use of any product or circuit described in this document. Any information provided in this document, including any sample design information or programming code, is provided only for reference purposes. It is the responsibility of the user of this document to properly design, program, and test the functionality and safety of any application made of this information and any resulting product. "High-Risk Device" means any device or system whose failure could cause personal injury, death, or property damage. Examples of High-Risk Devices are weapons, nuclear installations, surgical implants, and other medical devices. "Critical Component" means any component of a High-Risk Device whose failure to perform can be reasonably expected to cause, directly or indirectly, the failure of the High-Risk Device, or to affect its safety or effectiveness. Cypress is not liable, in whole or in part, and you shall and hereby do release Cypress from any claim, damage, or other liability arising from any use of a Cypress product as a Critical Component in a High-Risk Device. You shall indemnify and hold Cypress, its directors, officers, employees, agents, affiliates, distributors, and assigns harmless from and against all claims, costs, damages, and expenses, arising out of any claim, including claims for product liability, personal injury or death, or property damage arising from any use of a Cypress product as a Critical Component in a High-Risk Device. Cypress products are not intended or authorized for use as a Critical Component in any High-Risk Device except to the limited extent that (i) Cypress's published data sheet for the product explicitly states Cypress has qualified the product for use in a specific High-Risk Device, or (ii) Cypress has given you advance written authorization to use the product as a Critical Component in the specific High-Risk Device and you have signed a separate indemnification agreement.

Cypress, the Cypress logo, Spansion, the Spansion logo, and combinations thereof, WICED, PSoC, CapSense, EZ-USB, F-RAM, and Traveo are trademarks or registered trademarks of Cypress in the United States and other countries. For a more complete list of Cypress trademarks, visit [cypress.com](http://cypress.com). Other names and brands may be claimed as property of their respective owners.

## Looking for pricing, stock, or lifecycle information?

Click below to explore more details on WIN SOURCE:

-  [View CY62157EV30LL-45BVXI on WIN SOURCE](#)
-  [Cypress Semiconductor Corp Information](#)

## Optimize Your Supply Chain with WIN SOURCE Solutions

-  Global Sourcing Solution
-  Obsolete Management
-  Cost Control Management
-  Shortage Management
-  Alternative Solution
-  Excess Inventory Management