



**THE DATASHEET OF
CY62157EV18LL-55BVXIT**



8-Mbit (512 K × 16) Static RAM

Features

- Very high speed: 55 ns
- Wide voltage range: 1.65 V–2.25 V
- Pin compatible with CY62157DV18 and CY62157DV20
- Ultra low standby power
 - Typical Standby current: 2 μA
 - Maximum Standby current: 8 μA
- Ultra low active power
 - Typical active current: 1.8 mA at f = 1 MHz
- Easy memory expansion with \overline{CE}_1 , CE_2 and \overline{OE} features
- Automatic power down when deselected
- Complementary metal oxide semiconductor (CMOS) for optimum speed and power
- Available in Pb-free 48-ball very fine-pitch ball grid array (VFBGA) package

Functional Description

The CY62157EV18 is a high performance CMOS static RAM organized as 512K words by 16 bits. This device features advanced circuit design to provide ultra low active current. This is ideal for providing More Battery Life™ (MoBL®) in portable applications such as cellular telephones. The device also has an automatic power down feature that significantly reduces power

consumption when addresses are not toggling. The device can also be put into standby mode when deselected (\overline{CE}_1 HIGH or CE_2 LOW or both \overline{BHE} and \overline{BLE} are HIGH). The input and output pins (I/O_0 through I/O_{15}) are placed in a high impedance state when:

- Deselected (\overline{CE}_1 HIGH or CE_2 LOW)
- Outputs are disabled (\overline{OE} HIGH)
- Both Byte High Enable and Byte Low Enable are disabled (\overline{BHE} , \overline{BLE} HIGH) or
- Write operation is active (\overline{CE}_1 LOW, CE_2 HIGH and \overline{WE} LOW).

Write to the device by taking Chip Enables (\overline{CE}_1 LOW and CE_2 HIGH) and Write Enable (\overline{WE}) input LOW. If Byte Low Enable (\overline{BLE}) is LOW, then data from I/O pins (I/O_0 through I/O_7), is written into the location specified on the address pins (A_0 through A_{18}). If Byte High Enable (\overline{BHE}) is LOW, then data from I/O pins (I/O_8 through I/O_{15}) is written into the location specified on the address pins (A_0 through A_{18}).

Read from the device by taking Chip Enables (\overline{CE}_1 LOW and CE_2 HIGH) and Output Enable (\overline{OE}) LOW while forcing the Write Enable (\overline{WE}) HIGH. If Byte Low Enable (\overline{BLE}) is LOW, then data from the memory location specified by the address pins appear on I/O_0 to I/O_7 . If Byte High Enable (\overline{BHE}) is LOW, then data from memory appears on I/O_8 to I/O_{15} . See the [Truth Table on page 13](#) for a complete description of read and write modes.

For a complete list of related documentation, [click here](#).

Product Portfolio

Product	V _{CC} Range (V)			Speed (ns)	Power Dissipation					
					Operating I _{CC} , (mA)				Standby, I _{SB2} (μA)	
	f = 1MHz		f = f _{max}							
	Min	Typ ^[1]	Max		Typ ^[1]	Max	Typ ^[1]	Max	Typ ^[1]	Max
CY62157EV18	1.65	1.8	2.25	55	1.8	3	18	25	2	8

Note

1. Typical values are included for reference only and are not guaranteed or tested. Typical values are measured at V_{CC} = V_{CC(typ)}, T_A = 25 °C.

Logic Block Diagram

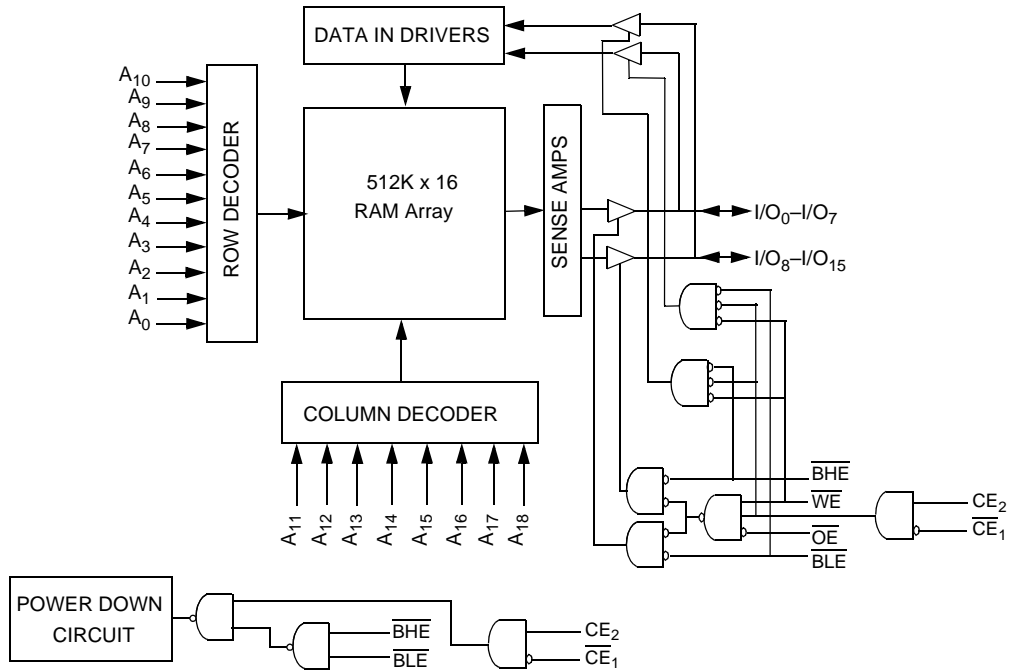

Contents

Pin Configuration	4	Package Diagram	15
Maximum Ratings	5	Acronyms	16
Operating Range	5	Document Conventions	16
Electrical Characteristics	5	Units of Measure	16
Capacitance	6	Document History	17
Thermal Resistance	6	Sales, Solutions, and Legal Information	19
AC Test Loads and Waveforms	6	Worldwide Sales and Design Support	19
Data Retention Characteristics	7	Products	19
Data Retention Waveform	7	PSoC® Solutions	19
Switching Characteristics	8	Cypress Developer Community	19
Switching Waveforms	9	Technical Support	19
Truth Table	13		
Ordering Information	14		
Ordering Code Definitions	14		

Pin Configuration

Figure 1. 48-ball VFBGA pinout (Top View) ^[2]

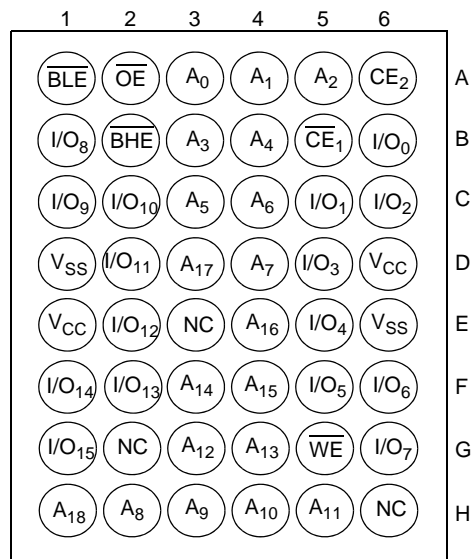

Note

2. NC pins are not connected on the die.

Maximum Ratings

Exceeding maximum ratings may shorten the useful life of the device. User guidelines are not tested.

Storage temperature -65 °C to + 150 °C

Ambient temperature with power applied -55 °C to + 125 °C

Supply voltage to ground potential -0.2 V to 2.45 V ($V_{CCmax} + 0.2$ V)

DC voltage applied to outputs in High-Z state ^[3, 4] -0.2 V to 2.45 V ($V_{CCmax} + 0.2$ V)

DC input voltage ^[3, 4] -0.2 V to 2.45 V ($V_{CCmax} + 0.2$ V)

Output current into outputs (LOW) 20 mA

Static discharge voltage (in accordance with MIL-STD-883, Method 3015) > 2001 V

Latch-up current > 200 mA

Operating Range

Device	Range	Ambient Temperature	V_{CC} ^[5]
CY62157EV18LL	Industrial	-40 °C to +85 °C	1.65 V to 2.25 V

Electrical Characteristics

Over the Operating Range

Parameter	Description	Test Conditions	55 ns			Unit
			Min	Typ ^[6]	Max	
V_{OH}	Output HIGH voltage	$I_{OH} = -0.1$ mA, $V_{CC} = 1.65$ V	1.4	–	–	V
V_{OL}	Output LOW voltage	$I_{OL} = 0.1$ mA, $V_{CC} = 1.65$ V	–	–	0.2	V
V_{IH}	Input HIGH voltage	$V_{CC} = 1.65$ V to 2.25 V	1.4	–	$V_{CC} + 0.2$ V	V
V_{IL}	Input LOW voltage	$V_{CC} = 1.65$ V to 2.25 V	-0.2	–	0.4	V
I_{IX}	Input leakage current	$GND \leq V_I \leq V_{CC}$	-1	–	+1	μ A
I_{OZ}	Output leakage current	$GND \leq V_O \leq V_{CC}$, output disabled	-1	–	+1	μ A
I_{CC}	V_{CC} operating supply current	$f = f_{max} = 1/t_{RC}$, $V_{CC} = V_{CC(max)}$, $I_{OUT} = 0$ mA CMOS levels	–	18	25	mA
		$f = 1$ MHz	–	1.8	3	mA
I_{SB1} ^[7]	Automatic CE power down current – CMOS inputs	$\overline{CE}_1 \geq V_{CC} - 0.2$ V or $CE_2 \leq 0.2$ V, $V_{IN} \geq V_{CC} - 0.2$ V, $V_{IN} \leq 0.2$ V), $f = f_{max}$ (address and data only), $f = 0$ (OE, WE, BHE and BLE), $V_{CC} = V_{CC(max)}$.	–	2	8	μ A
I_{SB2} ^[7]	Automatic CE power down current – CMOS Inputs	$\overline{CE}_1 \geq V_{CC} - 0.2$ V or $CE_2 \leq 0.2$ V, $V_{IN} \geq V_{CC} - 0.2$ V or $V_{IN} \leq 0.2$ V, $f = 0$, $V_{CC} = V_{CC(max)}$.	–	2	8	μ A

Notes

- $V_{IL(min)}$ = -2.0 V for pulse durations less than 20 ns.
- $V_{IH(max)}$ = $V_{CC} + 0.5$ V for pulse durations less than 20 ns.
- Full Device AC operation assumes a 100 μ s ramp time from 0 to V_{CC} (min) and 200 μ s wait time after V_{CC} stabilization.
- Typical values are included for reference only and are not guaranteed or tested. Typical values are measured at $V_{CC} = V_{CC(typ)}$, $T_A = 25$ °C.
- Chip enable (\overline{CE}) and byte enables (\overline{BHE} and \overline{BLE}) need to be tied to CMOS levels to meet the $I_{SB1}/I_{SB2}/I_{CCDR}$ spec. Other inputs can be left floating.

Capacitance

Parameter [8]	Description	Test Conditions	Max	Unit
C _{IN}	Input capacitance	T _A = 25 °C, f = 1 MHz, V _{CC} = V _{CC(typ)}	10	pF
C _{OUT}	Output capacitance		10	pF

Thermal Resistance

Parameter [8]	Description	Test Conditions	BGA	Unit
θ _{JA}	Thermal resistance (junction to ambient)	Still air, soldered on a 3 x 4.5 inch, four-layer printed circuit board	48.34	°C/W
θ _{JC}	Thermal resistance (junction to case)		8.78	°C/W

AC Test Loads and Waveforms

Figure 2. AC Test Loads and Waveforms

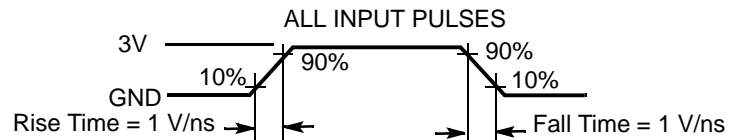
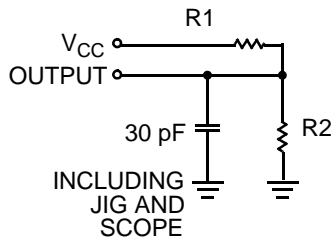

Equivalent to: THEVENIN EQUIVALENT



Parameters	Value	Unit
R1	13500	Ω
R2	10800	Ω
R _{TH}	6000	Ω
V _{TH}	0.80	V

Note

8. Tested initially and after any design or process changes that may affect these parameters.

Data Retention Characteristics

Over the Operating Range

Parameter	Description	Conditions	Min	Typ ^[9]	Max	Unit
V_{DR}	V_{CC} for data retention		1.0	–	–	V
I_{CCDR} ^[10]	Data retention current	$V_{CC} = V_{DR}$, $\overline{CE}_1 \geq V_{CC} - 0.2\text{ V}$, $CE_2 \leq 0.2\text{ V}$, $V_{IN} \geq V_{CC} - 0.2\text{ V}$ or $V_{IN} \leq 0.2\text{ V}$	–	1	3	μA
t_{CDR} ^[11]	Chip deselect to data retention time		0	–	–	ns
t_R ^[12]	Operation recovery time		55	–	–	ns

Data Retention Waveform

Figure 3. Data Retention Waveform^[13]

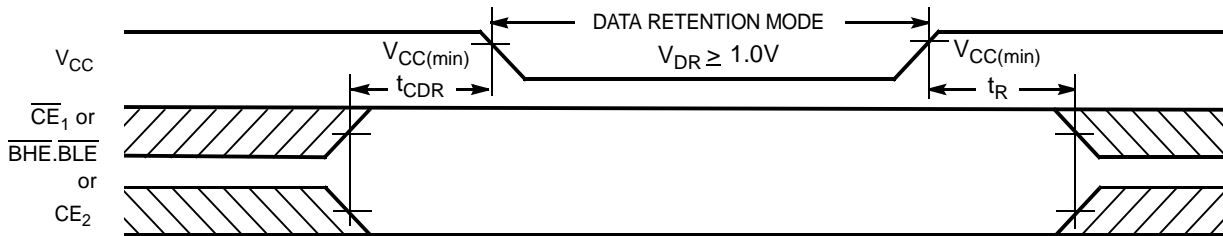

Notes

- Typical values are included for reference only and are not guaranteed or tested. Typical values are measured at $V_{CC} = V_{CC(typ)}$, $T_A = 25\text{ }^\circ\text{C}$.
- Chip enable (\overline{CE}) and byte enables (\overline{BHE} and \overline{BLE}) need to be tied to CMOS levels to meet the $I_{SB1}/I_{SB2}/I_{CCDR}$ spec. Other inputs can be left floating.
- Tested initially and after any design or process changes that may affect these parameters.
- Full device operation requires linear V_{CC} ramp from V_{DR} to $V_{CC(min)} \geq 100\text{ }\mu\text{s}$ or stable at $V_{CC(min)} \geq 100\text{ }\mu\text{s}$.
- $\overline{BHE.BLE}$ is the AND of both \overline{BHE} and \overline{BLE} . Deselect the chip by either disabling chip enable signals or by disabling both \overline{BHE} and \overline{BLE} .

Switching Characteristics

Over the Operating Range

Parameter ^[14, 15]	Description	55 ns		Unit
		Min	Max	
Read Cycle				
t _{RC}	Read cycle time	55	–	ns
t _{AA}	Address to data valid	–	55	ns
t _{OHA}	Data hold from address change	10	–	ns
t _{ACE}	\overline{CE}_1 LOW and CE ₂ HIGH to data valid	–	55	ns
t _{DOE}	\overline{OE} LOW to data valid	–	25	ns
t _{LZOE}	\overline{OE} LOW to Low-Z ^[16]	5	–	ns
t _{HZOE}	\overline{OE} HIGH to High-Z ^[16, 17]	–	18	ns
t _{LZCE}	\overline{CE}_1 LOW and CE ₂ HIGH to Low-Z ^[16]	10	–	ns
t _{HZCE}	\overline{CE}_1 HIGH and CE ₂ LOW to High-Z ^[16, 17]	–	18	ns
t _{PU}	\overline{CE}_1 LOW and CE ₂ HIGH to power up	0	–	ns
t _{PD}	\overline{CE}_1 HIGH and CE ₂ LOW to power down	–	55	ns
t _{DBE}	$\overline{BLE}/\overline{BHE}$ LOW to data valid	–	55	ns
t _{LZBE} ^[18]	$\overline{BLE}/\overline{BHE}$ LOW to Low-Z ^[16]	10	–	ns
t _{HZBE}	$\overline{BLE}/\overline{BHE}$ HIGH to High-Z ^[16, 17]	–	18	ns
Write Cycle ^[19, 20]				
t _{WC}	Write cycle time	45	–	ns
t _{SCE}	\overline{CE}_1 LOW and CE ₂ HIGH to write end	35	–	ns
t _{AW}	Address setup to write end	35	–	ns
t _{HA}	Address hold from write end	0	–	ns
t _{SA}	Address setup to write start	0	–	ns
t _{PWE}	\overline{WE} pulse width	35	–	ns
t _{BW}	$\overline{BLE}/\overline{BHE}$ LOW to write end	35	–	ns
t _{SD}	Data setup to write end	25	–	ns
t _{HD}	Data hold from write end	0	–	ns
t _{HZWE}	\overline{WE} LOW to High-Z ^[16, 17]	–	18	ns
t _{LZWE}	\overline{WE} HIGH to Low-Z ^[16]	10	–	ns

Notes

14. Test conditions for all parameters other than tri-state parameters assume signal transition time of 1V/ns or less, timing reference levels of $V_{CC(typ)}/2$, input pulse levels of 0 to $V_{CC(typ)}$, and output loading of the specified I_{OL}/I_{OH} as shown in the [Figure 2 on page 6](#).
15. In an earlier revision of this device, under a specific application condition, READ and WRITE operations were limited to switching of the byte enable and/or chip enable signals as described in the Application Notes [AN13842](#) and [AN66311](#). However, the issue has been fixed and in production now, and hence, these Application Notes are no longer applicable. They are available for download on our website as they contain information on the date code of the parts, beyond which the fix has been in production.
16. At any given temperature and voltage condition, t_{HZCE} is less than t_{LZCE}, t_{HZBE} is less than t_{LZBE}, t_{HZOE} is less than t_{LZOE}, and t_{HZWE} is less than t_{LZWE} for any given device.
17. t_{HZOE}, t_{HZCE}, t_{HZBE}, and t_{HZWE} transitions are measured when the output enters a high impedance state.
18. If both byte enables are toggled together, this value is 10 ns.
19. The internal write time of the memory is defined by the overlap of \overline{WE} , $\overline{CE} = V_{IL}$, \overline{BHE} and/or $\overline{BLE} = V_{IL}$, and CE₂ = V_{IH}. All signals must be ACTIVE to initiate a write and any of these signals can terminate a write by going INACTIVE. The data input setup and hold timing must be referenced to the edge of the signal that terminates the write.
20. The minimum write cycle time for Write Cycle No. 3 (\overline{WE} controlled, \overline{OE} LOW) is the sum of t_{HZWE} and t_{SD}.

Switching Waveforms

Figure 4. Read Cycle 1 (Address Transition Controlled) [21, 22]

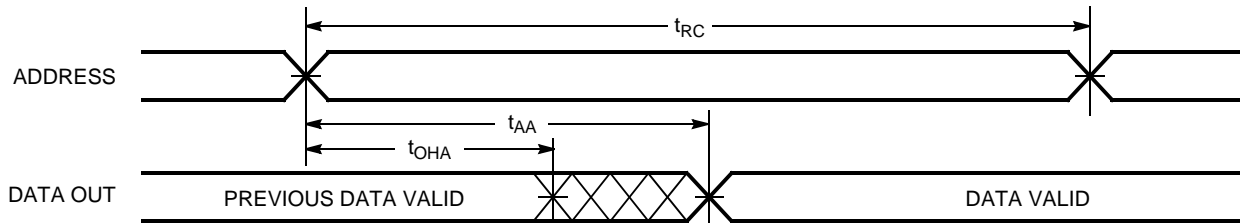
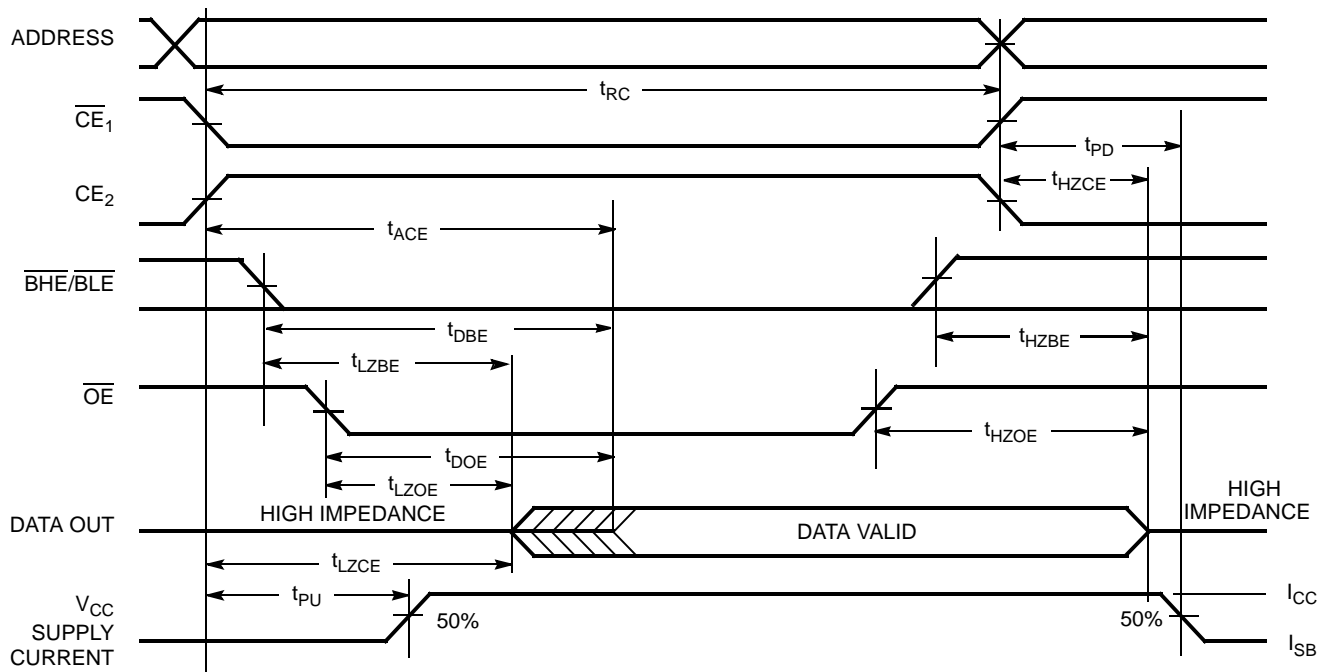

Figure 5. Read Cycle 2 (\overline{OE} Controlled) [22, 23]



Notes

21. The device is continuously selected. \overline{OE} , $\overline{CE}_1 = V_{IL}$, \overline{BHE} and/or $\overline{BLE} = V_{IL}$, and $CE_2 = V_{IH}$.

22. \overline{WE} is HIGH for read cycle.

23. Address valid before or similar to \overline{CE}_1 , \overline{BHE} , \overline{BLE} transition LOW and CE_2 transition HIGH.

Switching Waveforms (continued)

Figure 6. Write Cycle 1 (\overline{WE} Controlled) [24, 25, 26]

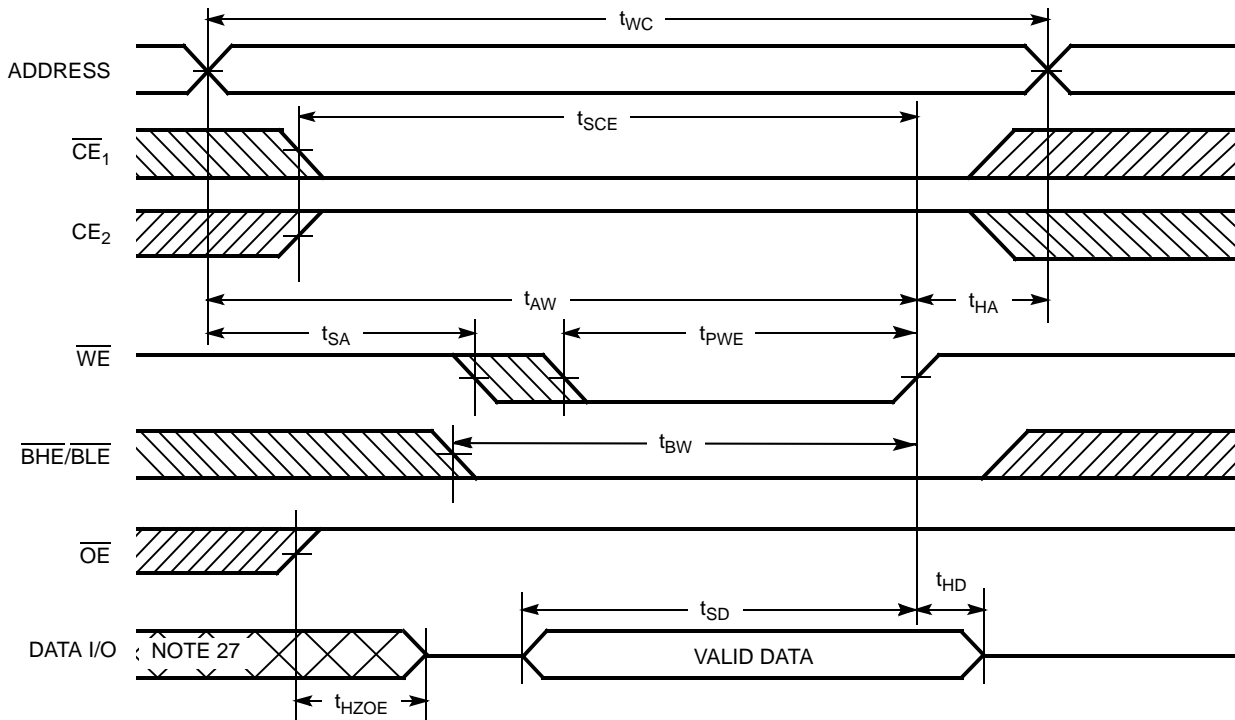

Notes

24. The internal write time of the memory is defined by the overlap of \overline{WE} , $\overline{CE} = V_{IL}$, \overline{BHE} and/or $\overline{BLE} = V_{IL}$, and $CE_2 = V_{IH}$. All signals must be ACTIVE to initiate a write and any of these signals can terminate a write by going INACTIVE. The data input setup and hold timing must be referenced to the edge of the signal that terminates the write.

25. Data I/O is high impedance if $\overline{OE} = V_{IH}$.

26. If \overline{CE}_1 goes HIGH and CE_2 goes LOW simultaneously with $\overline{WE} = V_{IH}$, the output remains in a high impedance state.

27. During this period, the I/Os are in output state and input signals must not be applied.

Switching Waveforms (continued)

Figure 7. Write Cycle 2 (\overline{CE}_1 or CE_2 Controlled) [28, 29, 30]

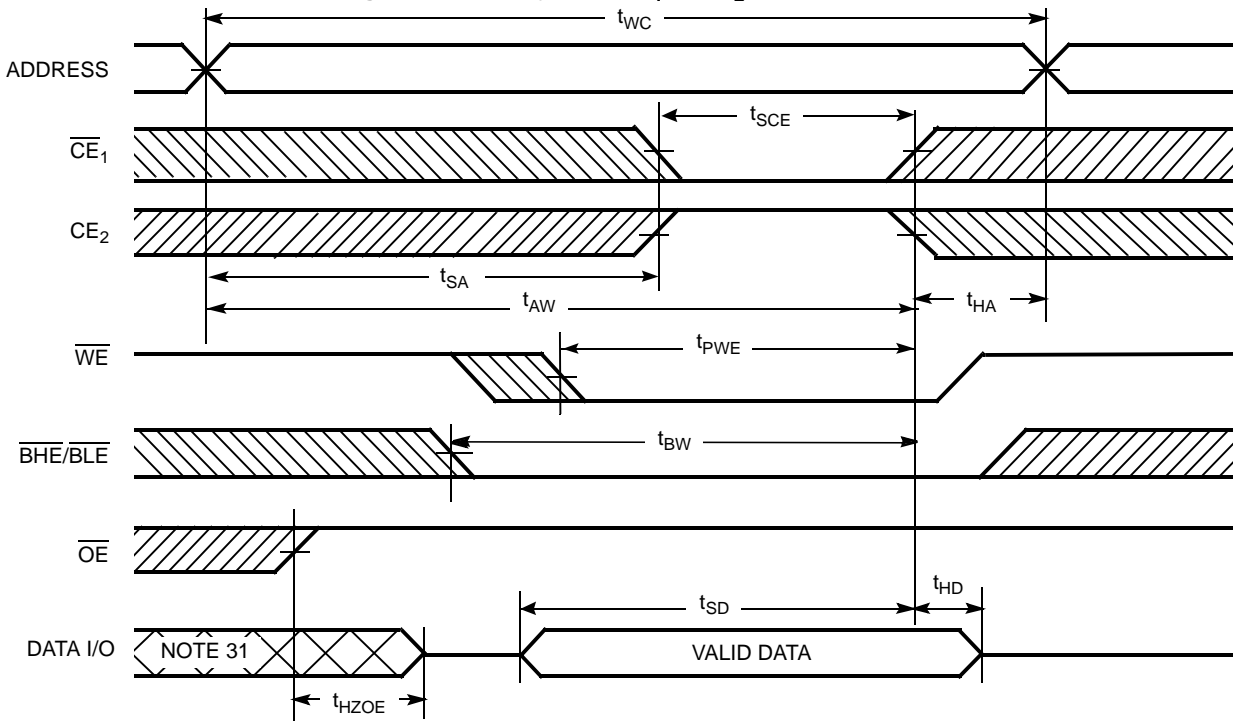

Notes

28. The internal write time of the memory is defined by the overlap of \overline{WE} , $\overline{CE} = V_{IL}$, \overline{BHE} and/or $\overline{BLE} = V_{IL}$, and $CE_2 = V_{IH}$. All signals must be ACTIVE to initiate a write and any of these signals can terminate a write by going INACTIVE. The data input setup and hold timing must be referenced to the edge of the signal that terminates the write.

29. Data I/O is high impedance if $\overline{OE} = V_{IH}$.

30. If \overline{CE}_1 goes HIGH and CE_2 goes LOW simultaneously with $\overline{WE} = V_{IH}$, the output remains in a high impedance state.

31. During this period, the I/Os are in output state and input signals must not be applied.

Switching Waveforms (continued)

Figure 8. Write Cycle 3 (\overline{WE} Controlled, \overline{OE} LOW) [32, 33]

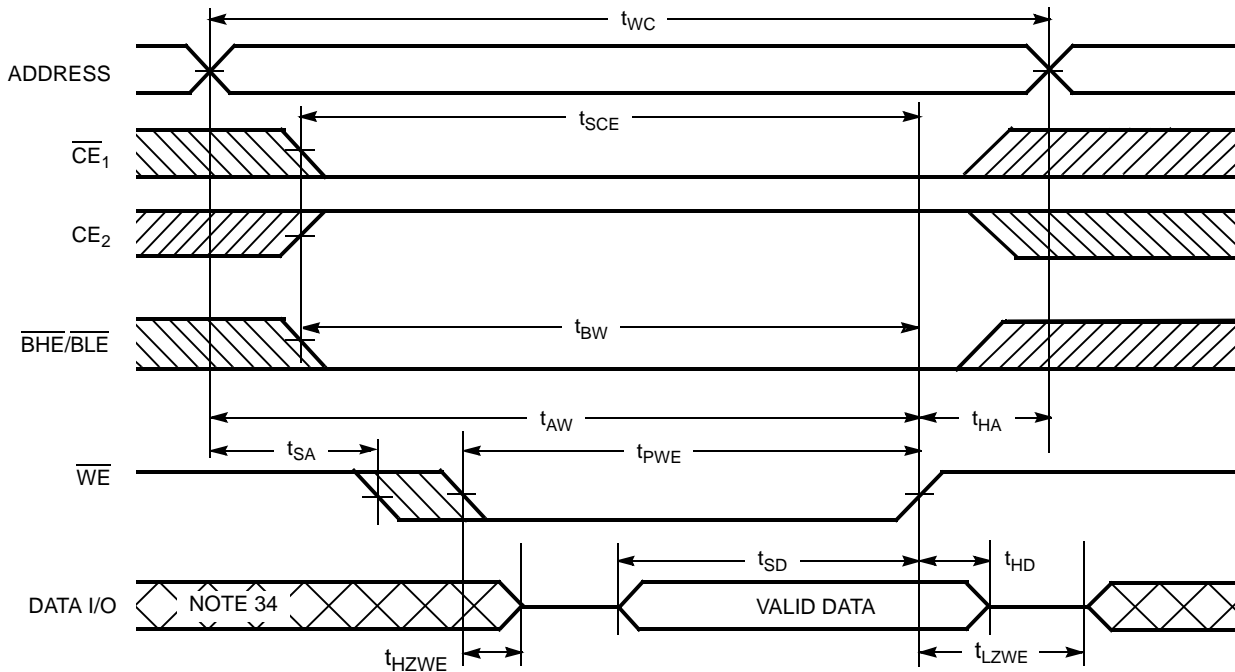
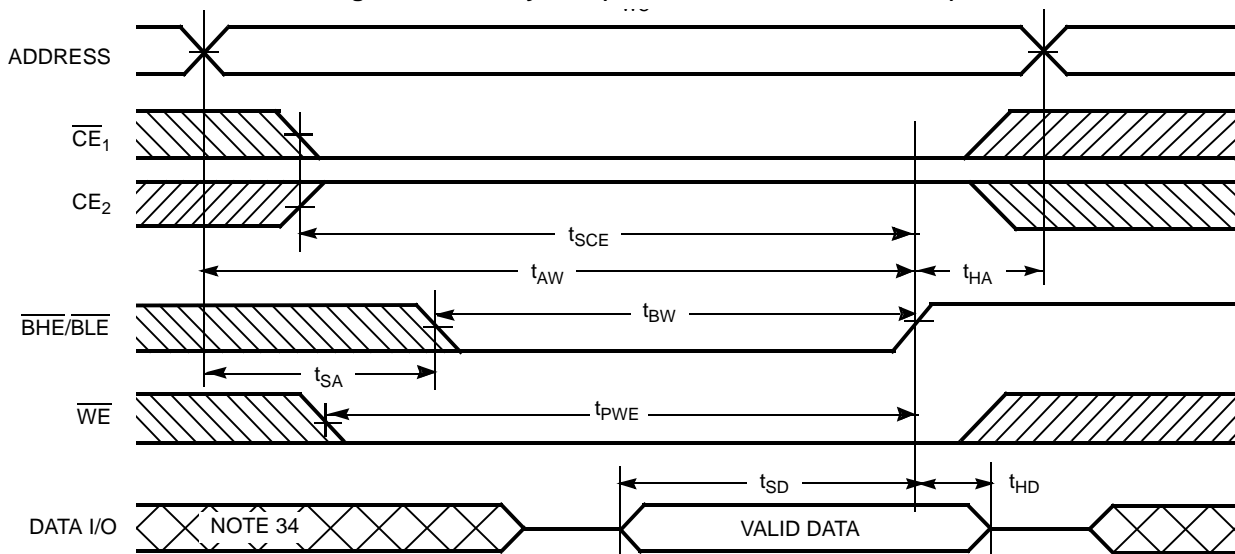

Figure 9. Write Cycle 4 ($\overline{BHE}/\overline{BLE}$ Controlled, \overline{OE} LOW) [32]



Notes

32. If \overline{CE}_1 goes HIGH and CE_2 goes LOW simultaneously with $\overline{WE} = V_{IH}$, the output remains in a high impedance state.

33. The minimum write cycle time for Write Cycle No. 3 (\overline{WE} controlled, \overline{OE} LOW) is the sum of t_{HZWE} and t_{SD} .

34. During this period, the I/Os are in output state and input signals must not be applied.

Truth Table

\overline{CE}_1	CE_2	\overline{WE}	\overline{OE}	\overline{BHE}	\overline{BLE}	Inputs/Outputs	Mode	Power
H	$\chi^{[35]}$	X	X	$\chi^{[35]}$	$\chi^{[35]}$	High-Z	Deselect/Power down	Standby (I_{SB})
$\chi^{[35]}$	L	X	X	$\chi^{[35]}$	$\chi^{[35]}$	High-Z	Deselect/Power down	Standby (I_{SB})
$\chi^{[35]}$	$\chi^{[35]}$	X	X	H	H	High-Z	Deselect/Power down	Standby (I_{SB})
L	H	H	L	L	L	Data out (I/O_0 – I/O_{15})	Read	Active (I_{CC})
L	H	H	L	H	L	Data out (I/O_0 – I/O_7); High-Z (I/O_8 – I/O_{15})	Read	Active (I_{CC})
L	H	H	L	L	H	High-Z (I/O_0 – I/O_7); Data out (I/O_8 – I/O_{15})	Read	Active (I_{CC})
L	H	H	H	L	H	High-Z	Output disabled	Active (I_{CC})
L	H	H	H	H	L	High-Z	Output disabled	Active (I_{CC})
L	H	H	H	L	L	High-Z	Output disabled	Active (I_{CC})
L	H	L	X	L	L	Data in (I/O_0 – I/O_{15})	Write	Active (I_{CC})
L	H	L	X	H	L	Data in (I/O_0 – I/O_7); High-Z (I/O_8 – I/O_{15})	Write	Active (I_{CC})
L	H	L	X	L	H	High-Z (I/O_0 – I/O_7); Data in (I/O_8 – I/O_{15})	Write	Active (I_{CC})

Note

35. The 'X' (Don't care) state for the Chip enables and Byte enables in the truth table refer to the logic state (either HIGH or LOW). Intermediate voltage levels on these pins is not permitted.

Ordering Information

Speed (ns)	Ordering Code	Package Diagram	Package Type	Operating Range
55	CY62157EV18LL-55BVXI	51-85150	48-ball VFBGA (Pb-free)	Industrial

Contact your local Cypress sales representative for availability of these parts.

Ordering Code Definitions

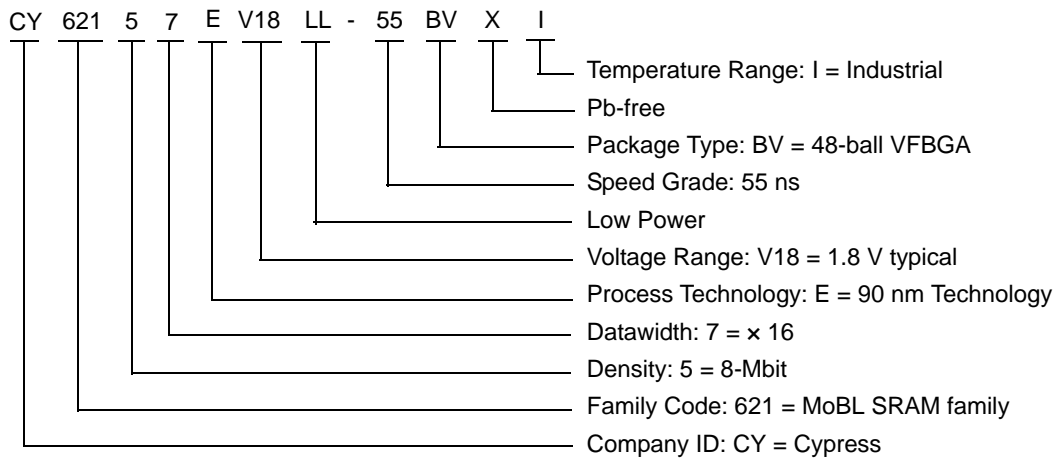

Package Diagram

Figure 10. 48-ball VFBGA (6 × 8 × 1 mm) BV48/BZ48 Package Outline, 51-85150

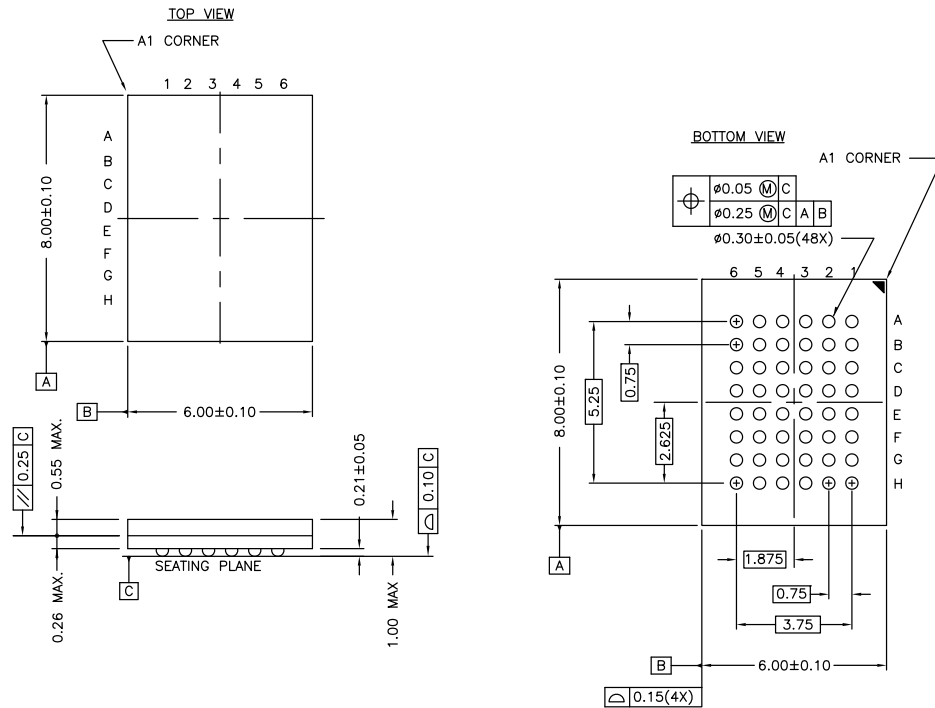

NOTE:
 PACKAGE WEIGHT: See Cypress Package Material Declaration Datasheet (PMDD) posted on the Cypress web.

51-85150 *H

Acronyms

Acronym	Description
BHE	Byte High Enable
BLE	Byte Low Enable
CE	Chip Enable
CMOS	Complementary Metal Oxide Semiconductor
I/O	Input/Output
OE	Output Enable
SRAM	Static Random Access Memory
VFBGA	Very Fine-Pitch Ball Grid Array
WE	Write Enable

Document Conventions

Units of Measure

Symbol	Unit of Measure
°C	degrees Celsius
μA	microampere
mA	milliampere
MHz	megahertz
ns	nanosecond
Ω	ohm
pF	picofarad
V	volt
W	watt

Document History

Document Title: CY62157EV18 MoBL [®] , 8-Mbit (512 K × 16) Static RAM				
Document Number: 38-05490				
Rev.	ECN No.	Issue Date	Orig. of Change	Description of Change
**	202862	See ECN	AJU	New data sheet
*A	291272	See ECN	SYT	Converted from Advance Information to Preliminary Changed V _{CC} Max from 2.20 to 2.25 V Changed V _{CC} stabilization time in footnote #7 from 100 μs to 200 μs Changed I _{CCDR} from 4 to 4.5 μA Changed t _{OHA} from 6 ns to 10 ns for both 35 ns and 45 ns Speed Bins Changed t _{DOE} from 15 and 22 ns to 18 and 22 ns for the 35 and 45 ns Speed Bins respectively Changed t _{HZOE} , t _{HZBE} and t _{HZWE} from 12 and 15 ns to 15 and 18 ns for the 35 and 45 ns Speed Bins respectively Changed t _{HZCE} from 12 and 15 ns to 18 and 22 ns for the 35 and 45 ns Speed Bins respectively Changed t _{SCE} , t _{AW} , and t _{BW} from 25 and 40 ns to 30 and 35 ns for the 35 and 45 ns Speed Bins respectively Changed t _{SD} from 15 and 20 ns to 18 and 22 ns for the 35 and 45 ns Speed Bins respectively Added Pb-Free Package Information
*B	444306	See ECN	NXR	Converted from Preliminary to Final Removed 35 ns speed bin and “L” bin Changed ball E3 from DNU to NC Removed redundant footnote on DNU Modified Maximum Ratings spec for Supply Voltage and DC Input Voltage from 2.4V to 2.45V Changed the I _{CC} Typ value from 16 mA to 18 mA and I _{CC} Max value from 28 mA to 25 mA for test condition f = fax = 1/t _{RC} Changed the I _{CC} Max value from 2.3 mA to 3 mA for test condition f = 1MHz Changed the I _{SB1} and I _{SB2} Max value from 4.5 μA to 8 μA and Typ value from 0.9 μA to 2 μA respectively Updated Thermal Resistance table Changed Test Load Capacitance from 50 pF to 30 pF Added Typ value for I _{CCDR} Changed the I _{CCDR} Max value from 4.5 μA to 3 μA Corrected t _R in Data Retention Characteristics from 100 μs to t _{RC} ns Changed t _{LZOE} from 3 to 5, changed t _{LZCE} from 6 to 10, changed t _{HZCE} from 22 to 18, changed t _{LZBE} from 6 to 5, changed t _{PWE} from 30 to 35, changed t _{SD} from 22 to 25, and changed t _{LZWE} from 6 to 10 Added footnote #13 Updated the ordering Information and replaced the Package Name column with Package Diagram
*C	571786	See ECN	VKN	Replaced 45ns speed bin with 55ns
*D	908120	See ECN	VKN	Added footnote #7 related to I _{SB2} Added footnote #12 related AC timing parameters
*E	2934396	06/03/10	VKN	Added footnote #23 related to chip enable Updated package diagram and template

Document History (continued)

Document Title: CY62157EV18 MoBL [®] , 8-Mbit (512 K × 16) Static RAM				
Document Number: 38-05490				
Rev.	ECN No.	Issue Date	Orig. of Change	Description of Change
*F	3110053	12/14/2010	PRAS	Changed Table Footnotes to Footnotes. Added Ordering Code Definitions.
*G	3243545	04/28/2011	RAME	Updated as per template. Added Acronyms and Units of Measure table.
*H	3295175	06/29/2011	RAME	Added I _{SB1} and I _{CCDR} to footnotes 7 and 11. Modified footnote 29 and referenced in Truth Table .
*I	4102022	08/22/2013	VINI	Updated Switching Characteristics : Updated Note 15. Updated Package Diagram : spec 51-85150 – Updated to the latest revision *H. Updated in new template.
*J	4384935	05/20/2014	MEMJ	Updated Switching Characteristics : Added Note 20 and referred the same note in “Write Cycle”. Updated Switching Waveforms : Added Note 33 and referred the same note in Figure 8 . Completing Sunset Review.
*K	4576526	11/21/2014	MEMJ	Added related documentation hyperlink in page 1.
*L	5759379	06/01/2017	VINI	Updated Thermal Resistance values. Updated the template.

Sales, Solutions, and Legal Information

Worldwide Sales and Design Support

Cypress maintains a worldwide network of offices, solution centers, manufacturer's representatives, and distributors. To find the office closest to you, visit us at [Cypress Locations](#).

Products

ARM® Cortex® Microcontrollers	cypress.com/arm
Automotive	cypress.com/automotive
Clocks & Buffers	cypress.com/timing
Interface	cypress.com/interface
Internet of Things	cypress.com/iot
Memory	cypress.com/memory
Microcontrollers	cypress.com/mcu
PSoC	cypress.com/psoc
Power Management ICs	cypress.com/pmic
Touch Sensing	cypress.com/touch
USB Controllers	cypress.com/usb
Wireless Connectivity	cypress.com/wireless

PSoC® Solutions

[PSoC 1](#) | [PSoC 3](#) | [PSoC 4](#) | [PSoC 5LP](#) | [PSoC 6](#)

Cypress Developer Community

[Forums](#) | [WICED IOT Forums](#) | [Projects](#) | [Video](#) | [Blogs](#) | [Training](#) | [Components](#)

Technical Support

cypress.com/support



© Cypress Semiconductor Corporation, 2004-2017. This document is the property of Cypress Semiconductor Corporation and its subsidiaries, including Spansion LLC ("Cypress"). This document, including any software or firmware included or referenced in this document ("Software"), is owned by Cypress under the intellectual property laws and treaties of the United States and other countries worldwide. Cypress reserves all rights under such laws and treaties and does not, except as specifically stated in this paragraph, grant any license under its patents, copyrights, trademarks, or other intellectual property rights. If the Software is not accompanied by a license agreement and you do not otherwise have a written agreement with Cypress governing the use of the Software, then Cypress hereby grants you a personal, non-exclusive, nontransferable license (without the right to sublicense) (1) under its copyright rights in the Software (a) for Software provided in source code form, to modify and reproduce the Software solely for use with Cypress hardware products, only internally within your organization, and (b) to distribute the Software in binary code form externally to end users (either directly or indirectly through resellers and distributors), solely for use on Cypress hardware product units, and (2) under those claims of Cypress's patents that are infringed by the Software (as provided by Cypress, unmodified) to make, use, distribute, and import the Software solely for use with Cypress hardware products. Any other use, reproduction, modification, translation, or compilation of the Software is prohibited.

TO THE EXTENT PERMITTED BY APPLICABLE LAW, CYPRESS MAKES NO WARRANTY OF ANY KIND, EXPRESS OR IMPLIED, WITH REGARD TO THIS DOCUMENT OR ANY SOFTWARE OR ACCOMPANYING HARDWARE, INCLUDING, BUT NOT LIMITED TO, THE IMPLIED WARRANTIES OF MERCHANTABILITY AND FITNESS FOR A PARTICULAR PURPOSE. To the extent permitted by applicable law, Cypress reserves the right to make changes to this document without further notice. Cypress does not assume any liability arising out of the application or use of any product or circuit described in this document. Any information provided in this document, including any sample design information or programming code, is provided only for reference purposes. It is the responsibility of the user of this document to properly design, program, and test the functionality and safety of any application made of this information and any resulting product. Cypress products are not designed, intended, or authorized for use as critical components in systems designed or intended for the operation of weapons, weapons systems, nuclear installations, life-support devices or systems, other medical devices or systems (including resuscitation equipment and surgical implants), pollution control or hazardous substances management, or other uses where the failure of the device or system could cause personal injury, death, or property damage ("Unintended Uses"). A critical component is any component of a device or system whose failure to perform can be reasonably expected to cause the failure of the device or system, or to affect its safety or effectiveness. Cypress is not liable, in whole or in part, and you shall and hereby do release Cypress from any claim, damage, or other liability arising from or related to all Unintended Uses of Cypress products. You shall indemnify and hold Cypress harmless from and against all claims, costs, damages, and other liabilities, including claims for personal injury or death, arising from or related to any Unintended Uses of Cypress products.

Cypress, the Cypress logo, Spansion, the Spansion logo, and combinations thereof, WICED, PSoC, CapSense, EZ-USB, F-RAM, and Traveo are trademarks or registered trademarks of Cypress in the United States and other countries. For a more complete list of Cypress trademarks, visit cypress.com. Other names and brands may be claimed as property of their respective owners.

Looking for pricing, stock, or lifecycle information?

Click below to explore more details on WIN SOURCE:

-  [View CY62157EV18LL-55BVXIT on WIN SOURCE](#)
-  [Cypress Semiconductor Corp Information](#)

Optimize Your Supply Chain with WIN SOURCE Solutions

-  Global Sourcing Solution
-  Obsolete Management
-  Cost Control Management
-  Shortage Management
-  Alternative Solution
-  Excess Inventory Management