



**THE DATASHEET OF
CY62148EV30LL-45BVXI**



Features

- Very high speed: 45 ns
 - Wide voltage range: 2.20 V to 3.60 V
- Temperature range:
 - Industrial: -40 °C to +85 °C
 - Automotive-A: -40 °C to +85 °C
- Pin compatible with CY62148DV30
- Ultra low standby power
 - Typical standby current: 1 μA
 - Maximum standby current: 7 μA (Industrial)
- Ultra low active power
 - Typical active current: 2 mA at f = 1 MHz
- Easy memory expansion with \overline{CE} and \overline{OE} features
- Automatic power down when deselected
- Complementary metal oxide semiconductor (CMOS) for optimum speed and power
- Available in Pb-free 36-ball very fine-pitch ball grid array (VFBGA), 32-pin thin small outline package (TSOP) II, and 32-pin small outline integrated circuit (SOIC)^[1] packages

Functional Description

The CY62148EV30 is a high performance CMOS static RAM organized as 512K words by 8 bits. This device features advanced circuit design to provide ultra low active current. This is ideal for providing More Battery Life™ (MoBL®) in portable applications such as cellular telephones. The device also has an automatic power down feature that significantly reduces power consumption. Placing the device into standby mode reduces power consumption by more than 99 percent when deselected (\overline{CE} HIGH). The eight input and output pins (I/O₀ through I/O₇) are placed in a high impedance state when the device is deselected (\overline{CE} HIGH), the outputs are disabled (\overline{OE} HIGH), or during a write operation (\overline{CE} LOW and \overline{WE} LOW).

To write to the device, take Chip Enable (\overline{CE}) and Write Enable (\overline{WE}) inputs LOW. Data on the eight I/O pins (I/O₀ through I/O₇) is then written into the location specified on the address pins (A₀ through A₁₈).

To read from the device, take Chip Enable (\overline{CE}) and Output Enable (\overline{OE}) LOW while forcing Write Enable (\overline{WE}) HIGH. Under these conditions, the contents of the memory location specified by the address pins appear on the I/O pins.

For a complete list of related 1documentation, [click here](#).

Logic Block Diagram

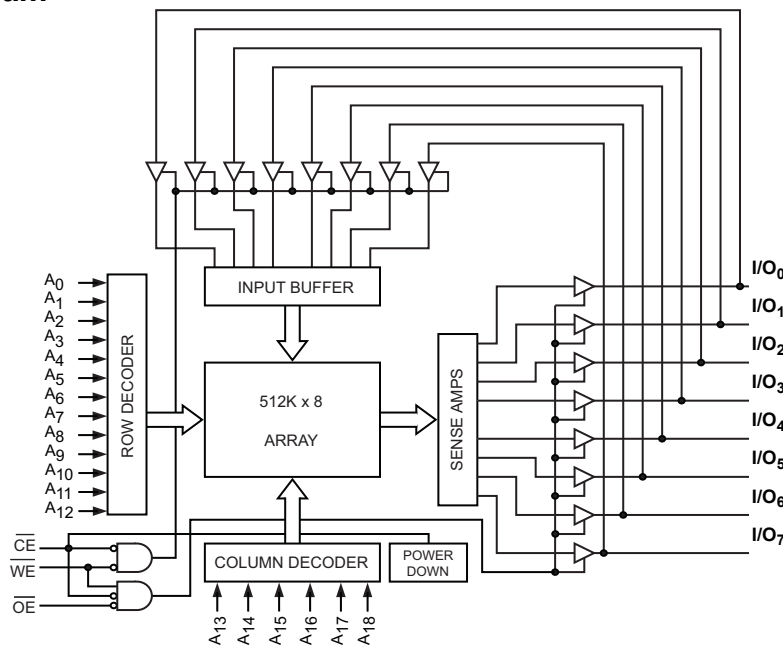

Note

1. SOIC package is available only in 55 ns speed bin.

Contents

Pin Configurations	3	Ordering Information	11
Product Portfolio	3	Ordering Code Definitions	11
Maximum Ratings	4	Package Diagrams	12
Operating Range	4	Acronyms	15
Electrical Characteristics	4	Document Conventions	15
Capacitance	5	Units of Measure	15
Thermal Resistance	5	Document History Page	16
AC Test Loads and Waveforms	5	Sales, Solutions, and Legal Information	19
Data Retention Characteristics	6	Worldwide Sales and Design Support	19
Data Retention Waveform	6	Products	19
Switching Characteristics	7	PSoC [®] Solutions	19
Switching Waveforms	8	Cypress Developer Community	19
Truth Table	10	Technical Support	19

Pin Configurations

VFPGA, SOIC and TSOP II pinouts are as follows. [2, 3]

**36-ball VFPGA pinout
Top View**

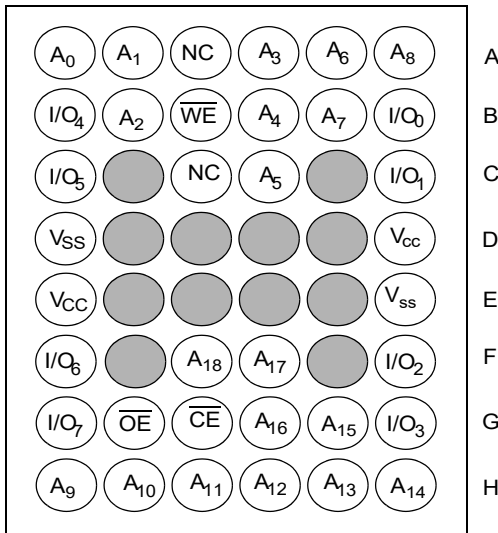

**32-pin SOIC/TSOP II pinout
Top View**

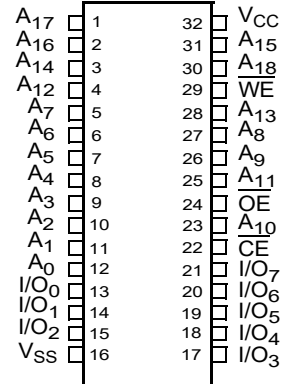

Product Portfolio

Product	Range	V _{CC} Range (V)	Speed (ns)	Power Dissipation								
				Operating I _{CC} (mA)				Standby I _{SB2} (μA)				
				f = 1 MHz		f = f _{max}						
Min	Typ ^[4]	Max	Typ ^[4]	Max	Typ ^[4]	Max	Typ ^[4]	Max				
CY62148EV30LL	VFPGA	Industrial	45	2.2	3.0	3.6	2	2.5	15	20	1	7
	TSOP II	Industrial / Automotive-A										
	SOIC	Industrial	55	2.2	3.0	3.6	2	2.5	15	20	1	7

Notes

- SOIC package is available only in 55 ns speed bin.
- NC pins are not connected on the die.
- Typical values are included for reference only and are not guaranteed or tested. Typical values are measured at V_{CC} = V_{CC(typ)}, T_A = 25 °C.

Maximum Ratings

Exceeding maximum ratings may impair the useful life of the device. These user guidelines are not tested.

Storage temperature	-65 °C to +150 °C
Ambient temperature with power applied	55 °C to +125 °C
Supply voltage to ground potential	-0.3 V to $V_{CC(max)}$ + 0.3 V
DC voltage applied to outputs in High Z State ^[5, 6]	-0.3 V to $V_{CC(max)}$ + 0.3 V

DC input voltage ^[5, 6]	-0.3 V to $V_{CC(max)}$ + 0.3 V
Output current into outputs (LOW)	20 mA
Static discharge voltage (MIL-STD-883, Method 3015)	> 2001 V
Latch up current	> 200 mA

Operating Range

Product	Range	Ambient Temperature	V_{CC} ^[7]
CY62148EV30	Industrial / Automotive-A	-40 °C to +85 °C	2.2 V to 3.6 V

Electrical Characteristics

Over the Operating Range

Parameter	Description	Test Conditions	-45 (Industrial / Automotive-A)			-55 ^[8]			Unit	
			Min	Typ ^[9]	Max	Min	Typ ^[9]	Max		
V _{OH}	Output high voltage	I _{OH} = -0.1 mA	2.0	-	-	2.0	-	-	V	
		I _{OH} = -1.0 mA, V _{CC} ≥ 2.70 V	2.4	-	-	2.4	-	-	V	
V _{OL}	Output low voltage	I _{OL} = 0.1 mA	-	-	0.4	-	-	0.2	V	
		I _{OL} = 2.1 mA, V _{CC} ≥ 2.70 V	-	-	0.4	-	-	0.4	V	
V _{IH}	Input high voltage	V _{CC} = 2.2 V to 2.7 V	1.8	-	V _{CC} + 0.3	1.8	-	V _{CC} + 0.3	V	
		V _{CC} = 2.7 V to 3.6 V	2.2	-	V _{CC} + 0.3	2.2	-	V _{CC} + 0.3	V	
V _{IL}	Input low voltage	V _{CC} = 2.2 V to 2.7 V	For VFBGA and TSOP II packages	-0.3	-	0.6	-	-	-	V
			For SOIC package	-	-	-	-0.3	-	0.4 ^[10]	V
		V _{CC} = 2.7 V to 3.6 V	For VFBGA and TSOP II packages	-0.3	-	0.8	-	-	-	V
			For SOIC package	-	-	-	-0.3	-	0.6 ^[10]	V
I _{IX}	Input leakage current	GND ≤ V _I ≤ V _C	-1	-	+1	-1	-	+1	μA	
I _{OZ}	Output leakage current	GND ≤ V _O ≤ V _{CC} , Output disabled	-1	-	+1	-1	-	+1	μA	
I _{CC}	V _{CC} operating supply current	f = f _{max} = 1/t _{RC}	V _{CC} = V _{CC(max)} , I _{OUT} = 0 mA, CMOS levels	-	15	20	-	15	20	mA
		f = 1 MHz		-	2	2.5	-	2	2.5	
I _{SB1} ^[11]	Automatic CE power down current – CMOS inputs	CE ≥ V _{CC} - 0.2 V, V _{IN} ≥ V _{CC} - 0.2 V, V _{IN} ≤ 0.2 V, f = f _{max} (Address and Data Only), f = 0 (OE and WE), V _{CC} = 3.60 V	-	1	7	-	1	7	μA	
I _{SB2} ^[11]	Automatic CE power down current – CMOS inputs	CE ≥ V _{CC} - 0.2 V, V _{IN} ≥ V _{CC} - 0.2 V or V _{IN} ≤ 0.2 V, f = 0, V _{CC} = 3.60 V	-	1	7	-	1	7	μA	

Notes

- V_{IL(min)} = -2.0 V for pulse durations less than 20 ns.
- V_{IH(max)} = V_{CC} + 0.75 V for pulse durations less than 20 ns.
- Full device AC operation assumes a minimum of 100 μs ramp time from 0 to V_{CC(min)} and 200 μs wait time after V_{CC} stabilization.
- SOIC package is available only in 55 ns speed bin.
- Typical values are included for reference only and are not guaranteed or tested. Typical values are measured at V_{CC} = V_{CC(typ)}, T_A = 25 °C.
- Under DC conditions the device meets a V_{IL} of 0.8V (for V_{CC} range of 2.7 V to 3.6 V) and 0.6 V (for V_{CC} range of 2.2 V to 2.7 V). However, in dynamic conditions Input LOW voltage applied to the device must not be higher than 0.6V and 0.4V for the above ranges. This is applicable to SOIC package only.
- Chip Enable (CE) must be HIGH at CMOS level to meet the I_{SB1} / I_{SB2} / I_{CCDR} spec. Other inputs can be left floating.

Capacitance

Parameter ^[12]	Description	Test Conditions	Max	Unit
C _{IN}	Input capacitance	T _A = 25 °C, f = 1 MHz, V _{CC} = V _{CC(typ)}	10	pF
C _{OUT}	Output capacitance		10	pF

Thermal Resistance

Parameter ^[12]	Description	Test Conditions	36-ball VFBGA Package	32-pin TSOP II Package	32-pin SOIC Package	Unit
Θ _{JA}	Thermal resistance (junction to ambient)	Still air, soldered on a 3 × 4.5 inch, four-layer printed circuit board	44.79	59.10	51.57	°C/W
Θ _{JC}	Thermal resistance (junction to case)		23.17	12.19	25.01	°C/W

AC Test Loads and Waveforms

Figure 1. AC Test Loads and Waveforms

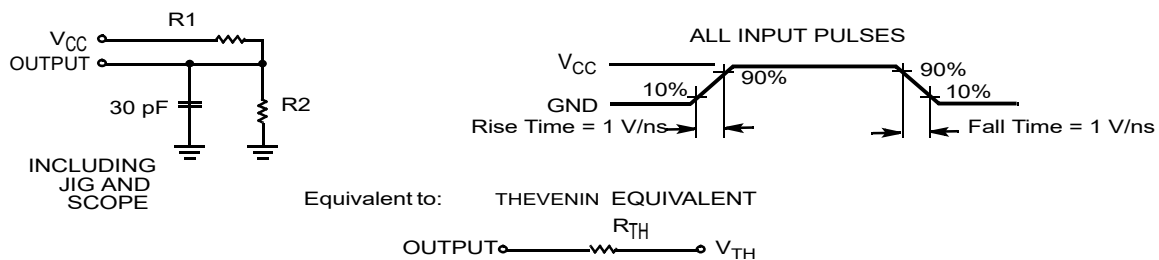

Parameters	2.50 V	3.0 V	Unit
R ₁	16667	1103	Ω
R ₂	15385	1554	Ω
R _{TH}	8000	645	Ω
V _{TH}	1.20	1.75	V

Note

12. Tested initially and after any design or process changes that may affect these parameters.

Data Retention Characteristics

Over the Operating Range

Parameter	Description	Conditions	Min	Typ ^[13]	Max	Unit
V_{DR}	V_{CC} for data retention		1.5	–	–	V
I_{CCDR} ^[14]	Data retention current	$V_{CC} = 1.5\text{ V}$, $\overline{CE} \geq V_{CC} - 0.2\text{ V}$, $V_{IN} \geq V_{CC} - 0.2\text{ V}$ or $V_{IN} \leq 0.2\text{ V}$	–	0.8	7	μA
t_{CDR} ^[15]	Chip deselect to data retention time		0	–	–	ns
t_R ^[16]	Operation recovery time	CY62148EV30LL-45	45	–	–	ns
		CY62148EV30LL-55	55	–	–	ns

Data Retention Waveform

Figure 2. Data Retention Waveform

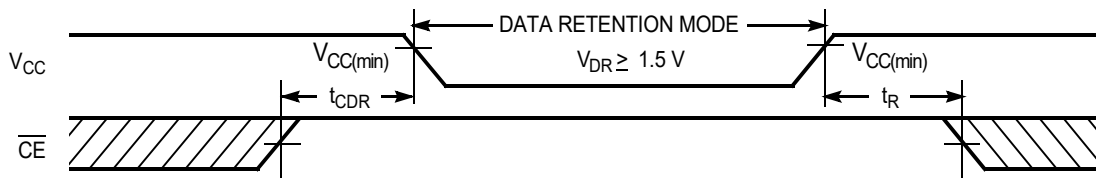

Notes

13. Typical values are included for reference only and are not guaranteed or tested. Typical values are measured at $V_{CC} = V_{CC(typ)}$, $T_A = 25\text{ }^\circ\text{C}$.
14. Chip Enable (\overline{CE}) must be HIGH at CMOS level to meet the $I_{SB1} / I_{SB2} / I_{CCDR}$ spec. Other inputs can be left floating.
15. Tested initially and after any design or process changes that may affect these parameters.
16. Full device AC operation requires linear V_{CC} ramp from V_{DR} to $V_{CC(min)} \geq 100\text{ }\mu\text{s}$ or stable at $V_{CC(min)} \geq 100\text{ }\mu\text{s}$.

Switching Characteristics

Over the Operating Range

Parameter ^[17, 18]	Description	-45 (Industrial / Automotive-A)		-55 ^[19]		Unit
		Min	Max	Min	Max	
Read Cycle						
t _{RC}	Read cycle time	45	–	55	–	ns
t _{AA}	Address to data valid	–	45	–	55	ns
t _{OHA}	Data hold from address change	10	–	10	–	ns
t _{ACE}	\overline{CE} LOW to data valid	–	45	–	55	ns
t _{DOE}	\overline{OE} LOW to data valid	–	22	–	25	ns
t _{LZOE}	\overline{OE} LOW to Low Z ^[20]	5	–	5	–	ns
t _{HZOE}	\overline{OE} HIGH to High Z ^[20, 21]	–	18	–	20	ns
t _{LZCE}	\overline{CE} LOW to Low Z ^[20]	10	–	10	–	ns
t _{HZCE}	\overline{CE} HIGH to High Z ^[20, 21]	–	18	–	20	ns
t _{PU}	\overline{CE} LOW to power-up	0	–	0	–	ns
t _{PD}	\overline{CE} HIGH to power-down	–	45	–	55	ns
Write Cycle ^[22, 23]						
t _{WC}	Write cycle time	45	–	55	–	ns
t _{SCE}	\overline{CE} LOW to write end	35	–	40	–	ns
t _{AW}	Address setup to write end	35	–	40	–	ns
t _{HA}	Address hold from write end	0	–	0	–	ns
t _{SA}	Address setup to write start	0	–	0	–	ns
t _{PWE}	\overline{WE} pulse width	35	–	40	–	ns
t _{SD}	Data setup to write end	25	–	25	–	ns
t _{HD}	Data hold from write end	0	–	0	–	ns
t _{HZWE}	\overline{WE} LOW to High Z ^[20, 21]	–	18	–	20	ns
t _{LZWE}	\overline{WE} HIGH to Low Z ^[20]	10	–	10	–	ns

Notes

17. In an earlier revision of this device, under a specific application condition, READ and WRITE operations were limited to switching of the chip enable signal as described in the Application Note AN66311. However, the issue has been fixed and in production now, and hence, this Application Note is no longer applicable. It is available for download on our website as it contains information on the date code of the parts, beyond which the fix has been in production.
18. Test Conditions for all parameters other than tri-state parameters assume signal transition time of 3 ns or less (1 V/ns), timing reference levels of $V_{CC(typ)}/2$, input pulse levels of 0 to $V_{CC(typ)}$, and output loading of the specified I_{OL}/I_{OH} as shown in the Figure 1 on page 5.
19. SOIC package is available only in 55 ns speed bin.
20. At any given temperature and voltage condition, t_{HZCE} is less than t_{LZCE}, t_{HZOE} is less than t_{LZOE}, and t_{HZWE} is less than t_{LZWE} for any given device.
21. t_{HZOE}, t_{HZCE}, and t_{HZWE} transitions are measured when the output enter a high impedance state.
22. The internal write time of the memory is defined by the overlap of \overline{WE} , $\overline{CE} = V_{IL}$. All signals must be ACTIVE to initiate a write and any of these signals can terminate a write by going INACTIVE. The data input setup and hold timing must be referenced to the edge of the signal that terminates the write.
23. The minimum write cycle pulse width for Write Cycle No. 3 (\overline{WE} Controlled, \overline{OE} LOW) should be equal to the sum of t_{SD} and t_{HZWE}.

Switching Waveforms

Figure 3. Read Cycle No. 1 (Address Transition Controlled) [24, 25]

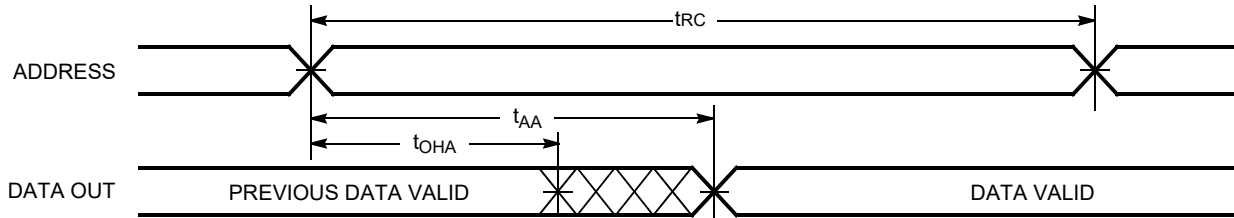

Figure 4. Read Cycle No. 2 (\overline{OE} Controlled) [25, 26]

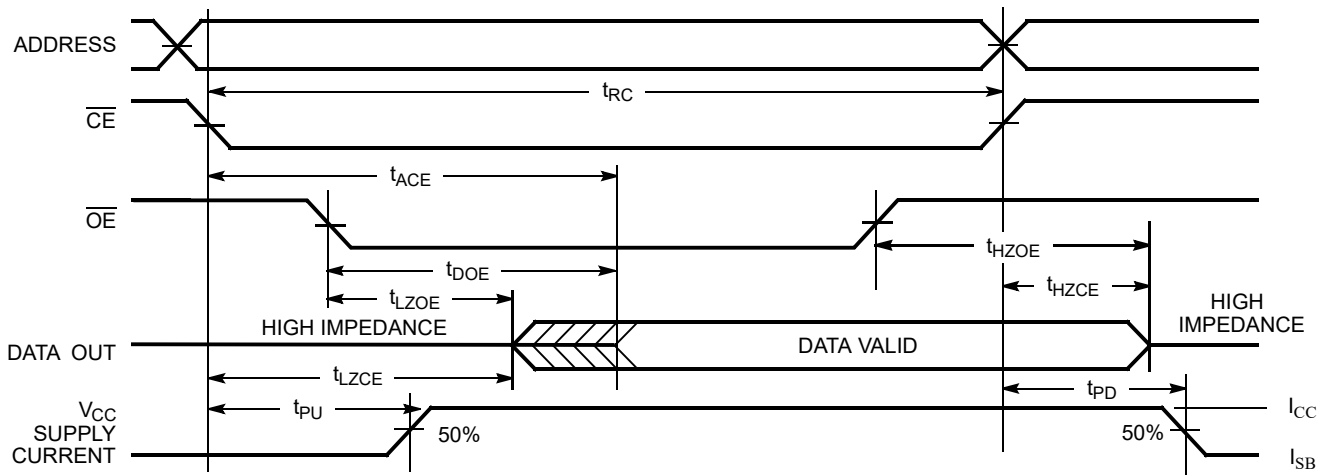
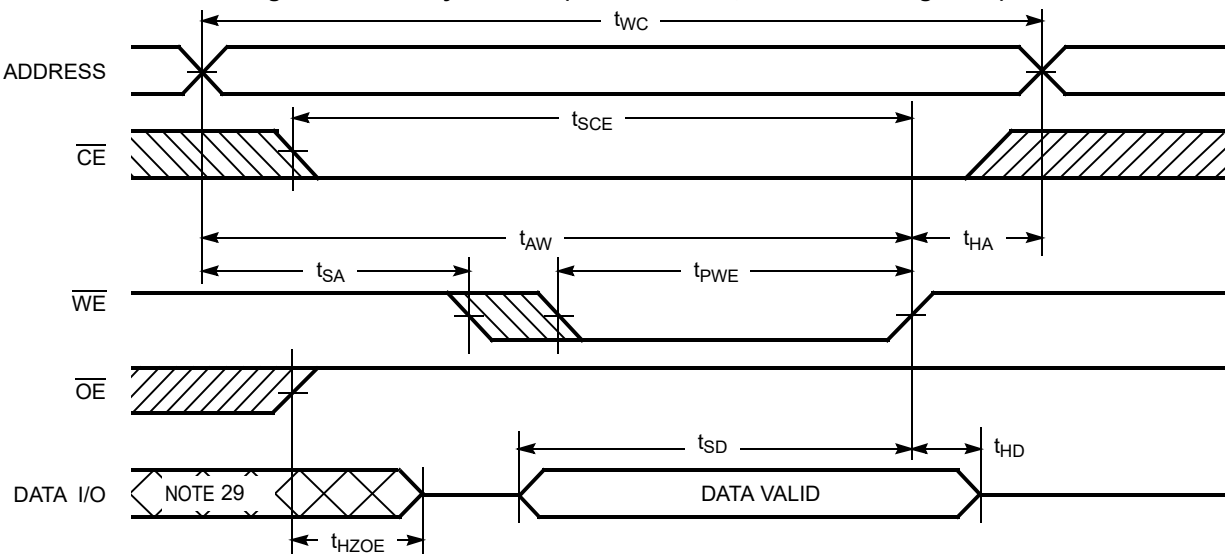

Figure 5. Write Cycle No. 1 (\overline{WE} Controlled, \overline{OE} HIGH During Write) [27, 28]



Notes

- 24. Device is continuously selected. \overline{OE} , $\overline{CE} = V_{IL}$.
- 25. \overline{WE} is HIGH for read cycles.
- 26. Address valid before or similar to \overline{CE} transition LOW.
- 27. Data I/O is high impedance if $\overline{OE} = V_{IH}$.
- 28. If \overline{CE} goes HIGH simultaneously with \overline{WE} HIGH, the output remains in high impedance state.
- 29. During this period, the I/Os are in output state. Do not apply input signals.

Switching Waveforms (continued)

Figure 6. Write Cycle No. 2 (\overline{CE} Controlled) [30, 31]

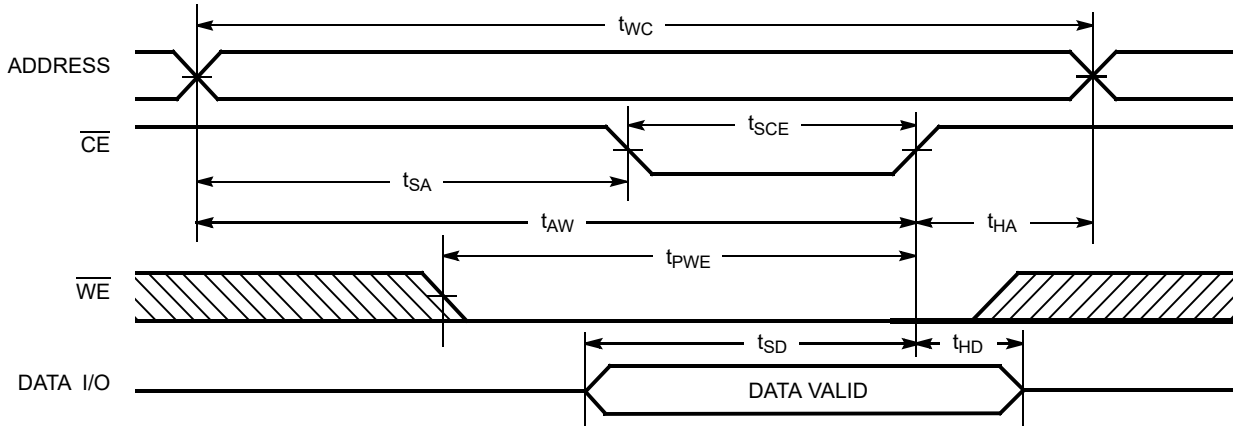
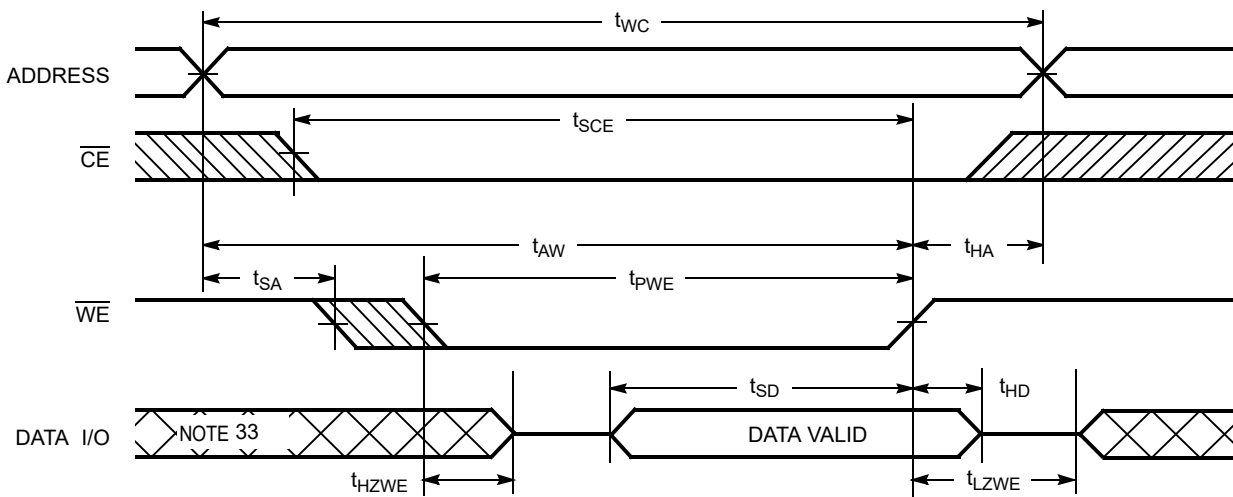

Figure 7. Write Cycle No. 3 (\overline{WE} Controlled, \overline{OE} LOW) [31, 32]



Notes

- 30. Data I/O is high impedance if $\overline{OE} = V_{IL}$.
- 31. If \overline{CE} goes HIGH simultaneously with \overline{WE} HIGH, the output remains in high impedance state.
- 32. The minimum write cycle pulse width should be equal to the sum of t_{SD} and t_{HZWE} .
- 33. During this period, the I/Os are in output state. Do not apply input signals.

Truth Table

$\overline{\text{CE}}$ ^[34]	$\overline{\text{WE}}$	$\overline{\text{OE}}$	Inputs/Outputs	Mode	Power
H	X	X	High Z	Deselect/Power down	Standby (I_{SB})
L	H	L	Data out	Read	Active (I_{CC})
L	H	H	High Z	Output disabled	Active (I_{CC})
L	L	X	Data in	Write	Active (I_{CC})

Note

34. Chip enable must be at CMOS levels (not floating). Intermediate voltage levels on this pin is not permitted.

Ordering Information

Speed (ns)	Ordering Code	Package Diagram	Package Type	Operating Range
45	CY62148EV30LL-45BVI	51-85149	36-ball VFBGA	Industrial
	CY62148EV30LL-45BVXI	51-85149	36-ball VFBGA (Pb-free)	
	CY62148EV30LL-45BVXIT	51-85149	36-ball VFBGA (Pb-free)	
	CY62148EV30LL-45ZSXI	51-85095	32-pin TSOP II (Pb-free)	
55	CY62148EV30LL-55SXI	51-85081	32-pin SOIC (Pb-free)	Industrial

Contact your local Cypress sales representative for availability of these parts.

Ordering Code Definitions

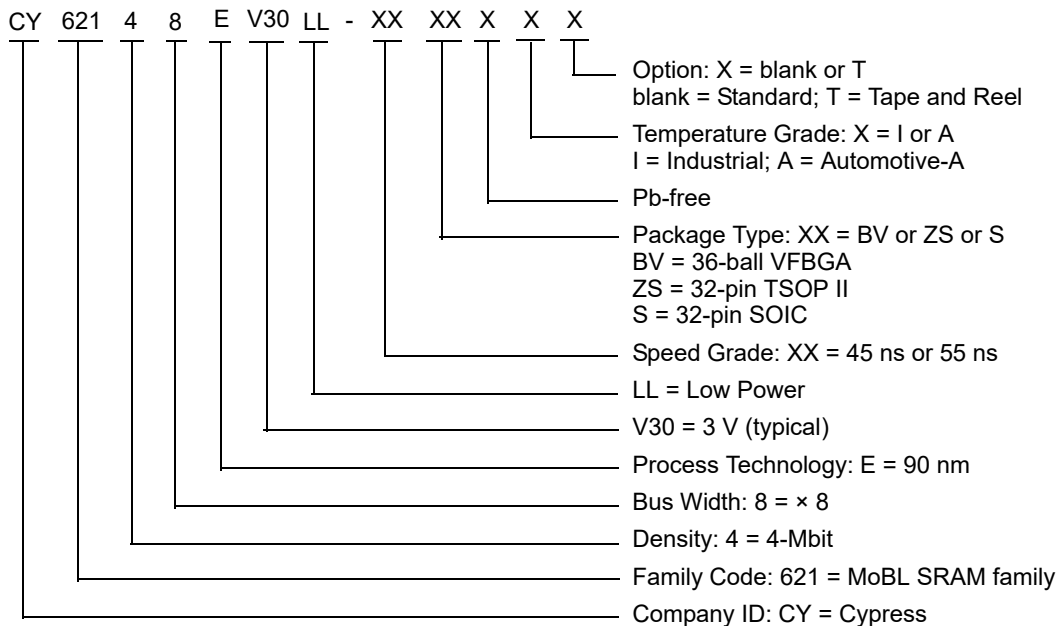

Package Diagrams

Figure 8. 36-ball VFBGA (8.0 × 6.0 × 1.0 mm) Package Outline, 51-85149

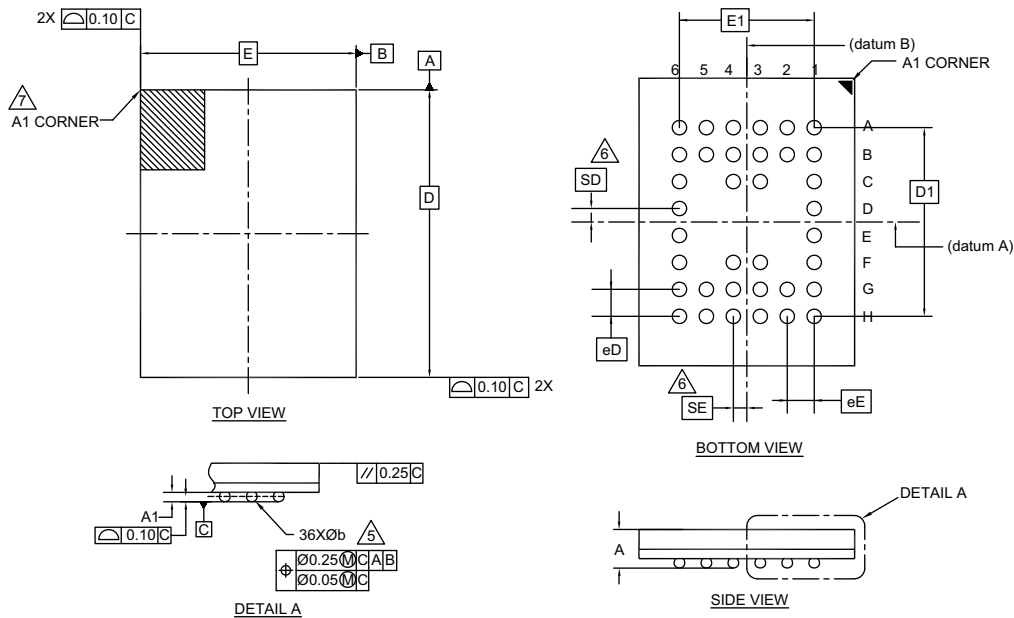

SYMBOL	DIMENSIONS		
	MIN.	NOM.	MAX.
A	-	-	1.00
A1	0.16	-	-
D	8.00 BSC		
E	6.00 BSC		
D1	5.25 BSC		
E1	3.75 BSC		
MD	8		
ME	6		
N	36		
∅ b	0.25	0.30	0.35
eD	0.75 BSC		
eE	0.75 BSC		
SD	0.375 BSC		
SE	0.375 BSC		

NOTES:

- ALL DIMENSIONS ARE IN MILLIMETERS.
 - SOLDER BALL POSITION DESIGNATION PER JEP95, SECTION 3, SPP-020.
 - "e" REPRESENTS THE SOLDER BALL GRID PITCH.
 - SYMBOL "MD" IS THE BALL MATRIX SIZE IN THE "D" DIRECTION. SYMBOL "ME" IS THE BALL MATRIX SIZE IN THE "E" DIRECTION. N IS THE NUMBER OF POPULATED SOLDER BALL POSITIONS FOR MATRIX SIZE MD X ME.
5. DIMENSION "b" IS MEASURED AT THE MAXIMUM BALL DIAMETER IN A PLANE PARALLEL TO DATUM C.
6. "SD" AND "SE" ARE MEASURED WITH RESPECT TO DATUMS A AND B AND DEFINE THE POSITION OF THE CENTER SOLDER BALL IN THE OUTER ROW WHEN THERE IS AN ODD NUMBER OF SOLDER BALLS IN THE OUTER ROW "SD" OR "SE" = 0. WHEN THERE IS AN EVEN NUMBER OF SOLDER BALLS IN THE OUTER ROW "SD" = eD/2 AND "SE" = eE/2.
7. A1 CORNER TO BE IDENTIFIED BY CHAMFER, LASER OR INK MARK METALIZED MARK, INDENTATION OR OTHER MEANS.
8. "+" INDICATES THE THEORETICAL CENTER OF DEPOPULATED SOLDER BALLS.

51-85149 *G

Package Diagrams (continued)

Figure 9. 32-pin TSOP II (20.95 × 11.76 × 1.0 mm) Package Outline, 51-85095

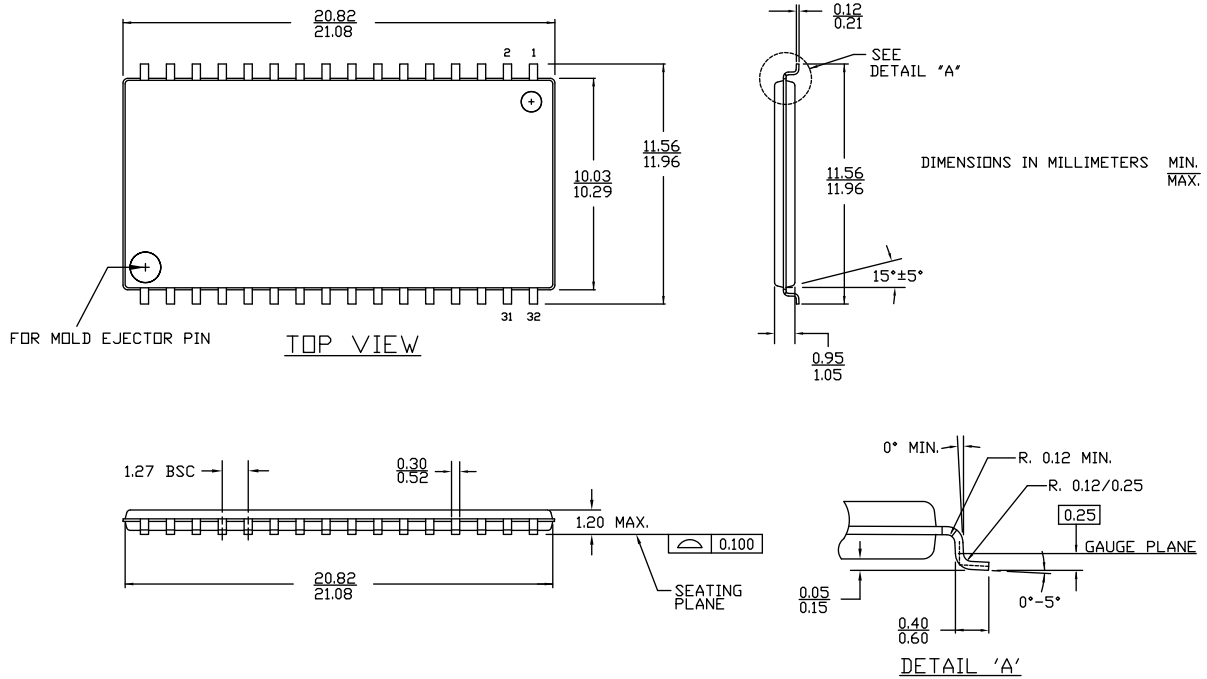

51-85095 *D

Package Diagrams (continued)

Figure 10. 32-pin SOIC (450 Mils) Package Outline, 51-85081

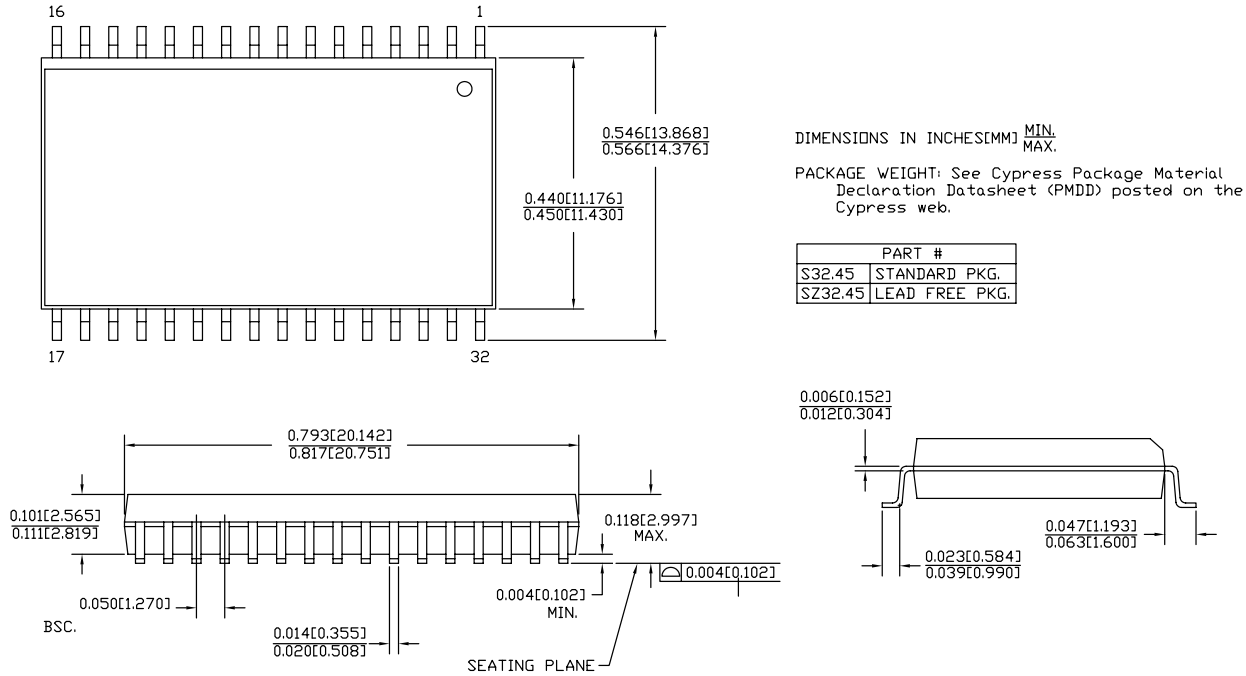

51-85081 *E

Acronyms

Acronym	Description
BHE	Byte High Enable
BLE	Byte Low Enable
CMOS	Complementary Metal Oxide Semiconductor
CE	Chip Enable
I/O	Input/Output
OE	Output Enable
SRAM	Static Random Access Memory
TSOP	Thin Small Outline Package
VFBGA	Very Fine-Pitch Ball Grid Array
WE	Write Enable

Document Conventions

Units of Measure

Symbol	Unit of Measure
°C	degree Celsius
μA	microampere
mA	milliampere
ns	nanosecond
pF	picofarad
V	volt
W	watt

Document History Page

Document Title: CY62148EV30 MoBL [®] , 4-Mbit (512K × 8) Static RAM				
Document Number: 38-05576				
Region	ECN	Orig. of Change	Submission Date	Description of Change
**	223225	AJU	05/05/2004	New data sheet.
*A	247373	SYT	07/28/2004	<p>Changed status from Advance Information to Preliminary.</p> <p>Updated Operating Range (Updated Note 7 (Changed V_{CC} stabilization time from 100 μs to 200 μs)).</p> <p>Updated Data Retention Characteristics (Changed maximum value of I_{CCDR} parameter from 2.0 μA to 2.5 μA; changed minimum value of t_R parameter from 100 μs to t_{RC} ns).</p> <p>Updated Switching Characteristics (Changed minimum value of t_{OHA} parameter from 6 ns to 10 ns for both 35 ns and 45 ns speed bin; changed maximum value of t_{DOE} parameter from 15 ns to 18 ns for 35 ns speed bin; changed maximum value of t_{HZOE}, t_{HZWE} parameters from 12 ns to 15 ns for 35 ns speed bin and 15 ns to 18 ns for 45 ns speed bin; changed minimum value of t_{SCE} from 25 ns to 30 ns for 35 ns speed bin and 40 ns to 35 ns for 45 ns speed bin; changed maximum value of t_{HZCE} parameter from 12 ns to 18 ns for 35 ns speed bin and 15 ns to 22 ns for 45 ns speed bin; changed minimum value of t_{SD} parameter from 15 ns to 18 ns for 35 ns speed bin and 20 ns to 22 ns for 45 ns speed bin).</p> <p>Updated Ordering Information (Updated part numbers (Changed to include Pb-free Packages)).</p>
*B	414807	ZSD	12/16/2005	<p>Changed status from Preliminary to Final.</p> <p>Changed the address of Cypress Semiconductor Corporation on page 1 from "3901 North First Street" to "198 Champion Court".</p> <p>Updated Features (Removed 35 ns speed bin).</p> <p>Updated Pin Configurations (Changed ball C3 from DNU to NC; removed the Note "DNU pins have to be left floating or tied to V_{SS} to ensure proper application." and its reference; added 32-pin SOIC pinout).</p> <p>Updated Electrical Characteristics (Removed "L" version of CY62148EV30; changed maximum value of I_{CC} parameter from 2 mA to 2.5 mA and typical value of I_{CC} parameter from 1.5 mA to 2 mA at $f = 1$ MHz; changed typical value of I_{CC} parameter from 12 mA to 15 mA at $f = f_{max}$; changed typical value of I_{SB1} and I_{SB2} parameters from 0.7 μA to 1 μA and maximum value of I_{SB1} and I_{SB2} parameters from 2.5 μA to 7 μA).</p> <p>Updated AC Test Loads and Waveforms (Changed the AC test load capacitance value from 50 pF to 30 pF).</p> <p>Updated Data Retention Characteristics (Changed maximum value of I_{CCDR} parameter from 2.5 μA to 7 μA; added typical value of I_{CCDR} parameter).</p> <p>Updated Switching Characteristics (Changed minimum value of t_{LZOE} parameter from 3 ns to 5 ns; changed minimum value of t_{LZCE} and t_{LZWE} parameters from 6 ns to 10 ns; changed maximum value of t_{HZCE} parameter from 22 ns to 18 ns; changed minimum value of t_{PWE} parameter from 30 ns to 35 ns; changed minimum value of t_{SD} from 22 ns to 25 ns).</p> <p>Updated Ordering Information:</p> <p>Updated part numbers.</p> <p>Removed "Package Name" column.</p> <p>Added "Package Diagram" column.</p> <p>Updated Package Diagrams:</p> <p>spec 51-85149 – Changed revision from *B to *C.</p> <p>Added spec 51-85081 *B.</p> <p>Updated to new template.</p>
*C	464503	NXR	05/25/2006	<p>Added Automotive Temperature Range related information in all instances across the document.</p> <p>Updated Ordering Information:</p> <p>Updated part numbers.</p>

Document History Page (continued)

Document Title: CY62148EV30 MoBL [®] , 4-Mbit (512K × 8) Static RAM				
Document Number: 38-05576				
Region	ECN	Orig. of Change	Submission Date	Description of Change
*D	833080	VKN	03/09/2007	Updated Electrical Characteristics : Added details of V _{IL} parameter corresponding to Test Condition “SOIC package”. Added Note 10 and referred the same note in the maximum value of V _{IL} parameter corresponding to SOIC package.
*E	890962	VKN	03/30/2007	Removed Automotive Temperature Range related information in all instances across the document. Updated Features (Added Note 1 and referred the same note in 32-pin SOIC package). Updated Electrical Characteristics (Added Note 11 and referred the same note in I _{SB2} parameter). Updated Switching Characteristics (Added values for all parameters corresponding to 55 ns Industrial Temperature Range). Updated Ordering Information (Updated part numbers).
*F	987940	VKN	04/18/2007	Updated Electrical Characteristics : Changed maximum value of V _{OL} parameter from 0.4 V to 0.2 V corresponding to Industrial Temperature Range at I _{OL} = 0.1 mA. Changed maximum value of V _{IL} parameter from 0.6 V to 0.4 V corresponding to Industrial Temperature Range, SOIC package at V _{CC} = 2.2 V to 2.7 V. Updated Note 10. Updated Note 11 (made the note applicable for both I _{SB2} and I _{CCDR} parameters).
*G	2548575	NXR	08/05/2008	Added Automotive-A Temperature Range related information in all instances across the document. Updated Ordering Information : Updated part numbers. Updated to new template.
*H	2769239	VKN / AESA	09/25/2009	Updated Ordering Information : Updated part numbers.
*I	2944332	VKN	06/04/2010	Updated Truth Table : Added Note 34 and referred the same note in “ \overline{CE} ” column. Updated Package Diagrams : spec 51-85149 – Changed revision from *C to *D. spec 51-85095 – Changed revision from ** to *A. spec 51-85081 – Changed revision from *B to *C.
*J	3007403	AJU	08/13/2010	Updated Ordering Information : No change in part numbers. Added Ordering Code Definitions . Updated to new template. Completing Sunset Review.
*K	3110202	PRAS	12/14/2010	Updated Logic Block Diagram . Updated Ordering Information : No change in part numbers. Updated Ordering Code Definitions .
*L	3302901	RAME	07/06/2011	Updated Functional Description : Updated description (Removed “For best practice recommendations, refer to the Cypress application note AN1064, SRAM System Guidelines.”). Updated Ordering Information : No change in part numbers. Updated Ordering Code Definitions . Updated Package Diagrams : spec 51-85095 – Changed revision from *A to *B.

Document History Page (continued)

Document Title: CY62148EV30 MoBL [®] , 4-Mbit (512K × 8) Static RAM				
Document Number: 38-05576				
Region	ECN	Orig. of Change	Submission Date	Description of Change
*L (cont.)	3302901	RAME	07/06/2011	Updated to new template. Completing Sunset Review.
*M	3363097	AJU	09/07/2011	Updated Data Retention Characteristics : Removed reference of Note 12 in I _{CCDR} parameter. Added Note 14 and referred the same note in I _{CCDR} parameter. Updated Package Diagrams : spec 51-85149 – Changed revision from *D to *E. spec 51-85081 – Changed revision from *C to *D.
*N	3546715	TAVA	03/09/2012	Updated Electrical Characteristics (Updated Note 10 (Removed the line “Refer to AN13470 for details”).).
*O	3733339	JISH	09/04/2012	Minor text edits. Completing Sunset Review.
*P	4102967	VINI	08/23/2013	Updated Switching Characteristics : Added Note 17 and referred the same note in “Parameter” column. Updated Package Diagrams : spec 51-85081 – Changed revision from *D to *E. Updated to new template. Completing Sunset Review.
*Q	4307881	NILE	04/09/2014	Updated Switching Characteristics : Updated description of t _{PD} parameter (Replaced “ \overline{CE} HIGH to power-up” with “ \overline{CE} HIGH to power-down”).
*R	4576526	NILE	11/21/2014	Updated Functional Description : Added “For a complete list of related 1documentation, click here. ” at the end. Updated Switching Characteristics : Added Note 23 and referred the same note in “Write Cycle”. Updated Switching Waveforms : Added Note 32 and referred the same note in Figure 7 .
*S	4802206	NILE	06/18/2015	Updated Package Diagrams : spec 51-85149 – Changed revision from *E to *F. spec 51-85095 – Changed revision from *B to *D. Updated to new template.
*T	5234869	NILE	04/22/2016	Updated Ordering Information : Updated part numbers. Updated Ordering Code Definitions (Added Tape and Reel option). Updated Package Diagrams : spec 51-85149 – Changed revision from *F to *G. Updated to new template.
*U	5480386	VINI	10/18/2016	Updated Thermal Resistance : Replaced “two-layer” with “four-layer” in “Test Conditions” column. Updated values of θ_{JA} parameter and θ_{JC} parameter corresponding to all packages. Updated to new template. Completing Sunset Review.
*V	6045156	VINI	01/25/2018	Updated Ordering Information : Updated part numbers. Updated to new template.
*W	6531864	VINI	04/03/2019	Updated to new template.

Sales, Solutions, and Legal Information

Worldwide Sales and Design Support

Cypress maintains a worldwide network of offices, solution centers, manufacturer's representatives, and distributors. To find the office closest to you, visit us at [Cypress Locations](#).

Products

Arm® Cortex® Microcontrollers	cypress.com/arm
Automotive	cypress.com/automotive
Clocks & Buffers	cypress.com/clocks
Interface	cypress.com/interface
Internet of Things	cypress.com/iot
Memory	cypress.com/memory
Microcontrollers	cypress.com/mcu
PSoC	cypress.com/psoc
Power Management ICs	cypress.com/pmic
Touch Sensing	cypress.com/touch
USB Controllers	cypress.com/usb
Wireless Connectivity	cypress.com/wireless

PSoC® Solutions

[PSoC 1](#) | [PSoC 3](#) | [PSoC 4](#) | [PSoC 5LP](#) | [PSoC 6 MCU](#)

Cypress Developer Community

[Community](#) | [Projects](#) | [Video](#) | [Blogs](#) | [Training](#) | [Components](#)

Technical Support

cypress.com/support



© Cypress Semiconductor Corporation, 2004–2019. This document is the property of Cypress Semiconductor Corporation and its subsidiaries ("Cypress"). This document, including any software or firmware included or referenced in this document ("Software"), is owned by Cypress under the intellectual property laws and treaties of the United States and other countries worldwide. Cypress reserves all rights under such laws and treaties and does not, except as specifically stated in this paragraph, grant any license under its patents, copyrights, trademarks, or other intellectual property rights. If the Software is not accompanied by a license agreement and you do not otherwise have a written agreement with Cypress governing the use of the Software, then Cypress hereby grants you a personal, non-exclusive, nontransferable license (without the right to sublicense) (1) under its copyright rights in the Software (a) for Software provided in source code form, to modify and reproduce the Software solely for use with Cypress hardware products, only internally within your organization, and (b) to distribute the Software in binary code form externally to end users (either directly or indirectly through resellers and distributors), solely for use on Cypress hardware product units, and (2) under those claims of Cypress's patents that are infringed by the Software (as provided by Cypress, unmodified) to make, use, distribute, and import the Software solely for use with Cypress hardware products. Any other use, reproduction, modification, translation, or compilation of the Software is prohibited.

TO THE EXTENT PERMITTED BY APPLICABLE LAW, CYPRESS MAKES NO WARRANTY OF ANY KIND, EXPRESS OR IMPLIED, WITH REGARD TO THIS DOCUMENT OR ANY SOFTWARE OR ACCOMPANYING HARDWARE, INCLUDING, BUT NOT LIMITED TO, THE IMPLIED WARRANTIES OF MERCHANTABILITY AND FITNESS FOR A PARTICULAR PURPOSE. No computing device can be absolutely secure. Therefore, despite security measures implemented in Cypress hardware or software products, Cypress shall have no liability arising out of any security breach, such as unauthorized access to or use of a Cypress product. CYPRESS DOES NOT REPRESENT, WARRANT, OR GUARANTEE THAT CYPRESS PRODUCTS, OR SYSTEMS CREATED USING CYPRESS PRODUCTS, WILL BE FREE FROM CORRUPTION, ATTACK, VIRUSES, INTERFERENCE, HACKING, DATA LOSS OR THEFT, OR OTHER SECURITY INTRUSION (collectively, "Security Breach"). Cypress disclaims any liability relating to any Security Breach, and you shall and hereby do release Cypress from any claim, damage, or other liability arising from any Security Breach. In addition, the products described in these materials may contain design defects or errors known as errata which may cause the product to deviate from published specifications. To the extent permitted by applicable law, Cypress reserves the right to make changes to this document without further notice. Cypress does not assume any liability arising out of the application or use of any product or circuit described in this document. Any information provided in this document, including any sample design information or programming code, is provided only for reference purposes. It is the responsibility of the user of this document to properly design, program, and test the functionality and safety of any application made of this information and any resulting product. "High-Risk Device" means any device or system whose failure could cause personal injury, death, or property damage. Examples of High-Risk Devices are weapons, nuclear installations, surgical implants, and other medical devices. "Critical Component" means any component of a High-Risk Device whose failure to perform can be reasonably expected to cause, directly or indirectly, the failure of the High-Risk Device, or to affect its safety or effectiveness. Cypress is not liable, in whole or in part, and you shall and hereby do release Cypress from any claim, damage, or other liability arising from any use of a Cypress product as a Critical Component in a High-Risk Device. You shall indemnify and hold Cypress, its directors, officers, employees, agents, affiliates, distributors, and assigns harmless from and against all claims, costs, damages, and expenses, arising out of any claim, including claims for product liability, personal injury or death, or property damage arising from any use of a Cypress product as a Critical Component in a High-Risk Device. Cypress products are not intended or authorized for use as a Critical Component in any High-Risk Device except to the limited extent that (i) Cypress's published data sheet for the product explicitly states Cypress has qualified the product for use in a specific High-Risk Device, or (ii) Cypress has given you advance written authorization to use the product as a Critical Component in the specific High-Risk Device and you have signed a separate indemnification agreement.

Cypress, the Cypress logo, Spansion, the Spansion logo, and combinations thereof, WICED, PSoC, CapSense, EZ-USB, F-RAM, and Traveo are trademarks or registered trademarks of Cypress in the United States and other countries. For a more complete list of Cypress trademarks, visit cypress.com. Other names and brands may be claimed as property of their respective owners.

Looking for pricing, stock, or lifecycle information?

Click below to explore more details on WIN SOURCE:

-  [View CY62148EV30LL-45BVXI on WIN SOURCE](#)
-  [Cypress Semiconductor Corp Information](#)

Optimize Your Supply Chain with WIN SOURCE Solutions

-  Global Sourcing Solution
-  Obsolete Management
-  Cost Control Management
-  Shortage Management
-  Alternative Solution
-  Excess Inventory Management