



**THE DATASHEET OF  
CY62137VNLL-70ZSXET**



## 2-Mbit (128K x 16) Static RAM

### Features

- **Temperature Ranges**
  - Industrial:  $-40^{\circ}\text{C}$  to  $85^{\circ}\text{C}$
  - Automotive-A:  $-40^{\circ}\text{C}$  to  $85^{\circ}\text{C}$
  - Automotive-E:  $-40^{\circ}\text{C}$  to  $125^{\circ}\text{C}$
- **High Speed: 55 ns**
- **Wide voltage range: 2.7V–3.6V**
- **Ultra-low active, standby power**
- **Easy memory expansion with  $\overline{\text{CE}}$  and  $\overline{\text{OE}}$  features**
- **TTL-compatible inputs and outputs**
- **Automatic power-down when deselected**
- **CMOS for optimum speed/power**
- **Available in Pb-free 44-pin TSOP Type II package**

### Functional Description<sup>[1]</sup>

The CY62137VN is a high-performance CMOS static RAM organized as 128K words by 16 bits. This device features advanced circuit design to provide ultra-low active current. This is ideal for providing More Battery Life™ (MoBL<sup>®</sup>) in

portable applications such as cellular telephones. The device also has an automatic power-down feature that reduces power consumption by 99% when addresses are not toggling. The device can also be put into standby mode when deselected ( $\overline{\text{CE}}$  HIGH) or when  $\overline{\text{CE}}$  is LOW and both  $\overline{\text{BLE}}$  and  $\overline{\text{BHE}}$  are HIGH. The input/output pins ( $\text{I/O}_0$  through  $\text{I/O}_{15}$ ) are placed in a high-impedance state when: deselected ( $\overline{\text{CE}}$  HIGH), outputs are disabled ( $\overline{\text{OE}}$  HIGH),  $\overline{\text{BHE}}$  and  $\overline{\text{BLE}}$  are disabled ( $\overline{\text{BHE}}$ ,  $\overline{\text{BLE}}$  HIGH), or during a write operation ( $\overline{\text{CE}}$  LOW, and  $\overline{\text{WE}}$  LOW). Writing to the device is accomplished by taking Chip Enable ( $\overline{\text{CE}}$ ) and Write Enable ( $\overline{\text{WE}}$ ) inputs LOW. If Byte Low Enable ( $\overline{\text{BLE}}$ ) is LOW, then data from I/O pins ( $\text{I/O}_0$  through  $\text{I/O}_7$ ), is written into the location specified on the address pins ( $\text{A}_0$  through  $\text{A}_{16}$ ). If Byte High Enable ( $\overline{\text{BHE}}$ ) is LOW, then data from I/O pins ( $\text{I/O}_8$  through  $\text{I/O}_{15}$ ) is written into the location specified on the address pins ( $\text{A}_0$  through  $\text{A}_{16}$ ). Reading from the device is accomplished by taking Chip Enable ( $\overline{\text{CE}}$ ) and Output Enable ( $\overline{\text{OE}}$ ) LOW while forcing the Write Enable ( $\overline{\text{WE}}$ ) HIGH. If Byte Low Enable ( $\overline{\text{BLE}}$ ) is LOW, then data from the memory location specified by the address pins will appear on  $\text{I/O}_0$  to  $\text{I/O}_7$ . If Byte High Enable ( $\overline{\text{BHE}}$ ) is LOW, then data from memory will appear on  $\text{I/O}_8$  to  $\text{I/O}_{15}$ . See the truth table at the back of this data sheet for a complete description of read and write modes.

### Logic Block Diagram

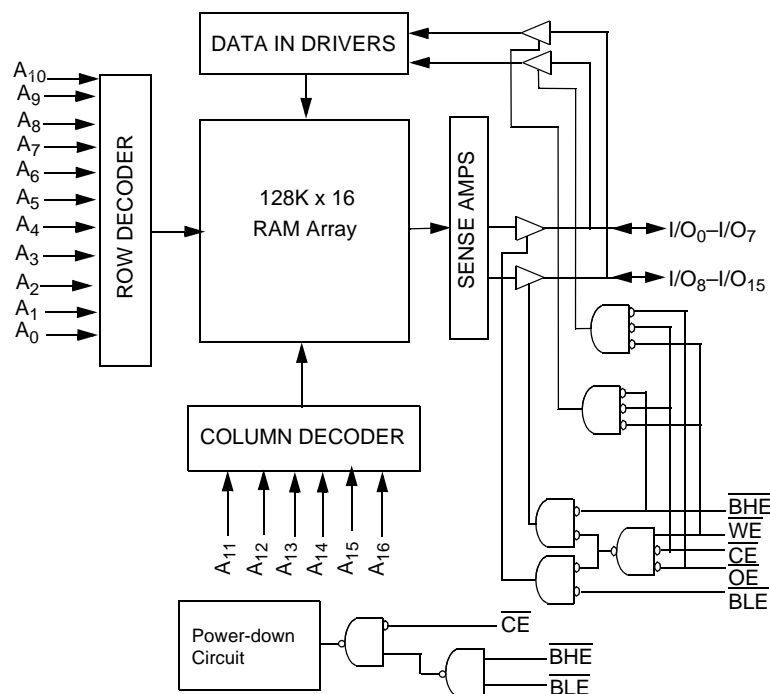

**Note:**

1. For best practice recommendations, please refer to the Cypress application note "System Design Guidelines" on <http://www.cypress.com>.

Product Portfolio

Product		V <sub>CC</sub> Range (V)			Speed (ns)	Power Dissipation			
						Operating, I <sub>CC</sub> (mA)		Standby, I <sub>SB2</sub> (μA)	
		Min.	Typ. <sup>[3]</sup>	Max.		Typ. <sup>[3]</sup>	Max.	Typ. <sup>[3]</sup>	Max.
CY62137VNLL	Industrial	2.7	3.0	3.6	55	7	20	1	15
CY62137VNLL					70	7	15	1	15
CY62137VNLL	Automotive-A				70	7	15	1	15
CY62137VNLL	Automotive-E				70	7	15	1	20

Pin Configurations

TSOP II (Forward)  
Top View

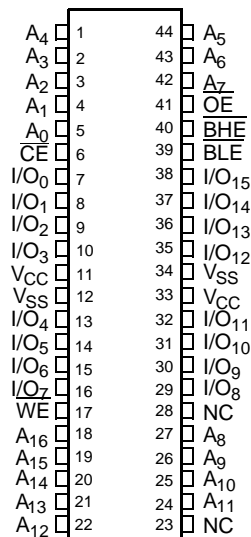

Pin Definitions

Pin Number	Type	Description
1–5, 18–22, 24–27, 42–45	Input	<b>A<sub>0</sub>–A<sub>16</sub></b> . Address Inputs
7–10, 13–16, 29–32, 35–38	Input/Output	<b>I/O<sub>0</sub>–I/O<sub>15</sub></b> . Data lines. Used as input or output lines depending on operation
23	No Connect	<b>NC</b> . This pin is not connected to the die
17	Input/Control	<b>WE</b> . When selected LOW, a WRITE is conducted. When selected HIGH, a READ is conducted
6	Input/Control	<b>CE</b> . When LOW, selects the chip. When HIGH, deselects the chip
40, 39	Input/Control	<b>Byte Write Select Inputs, active LOW</b> . <b>BHE</b> controls I/O <sub>15</sub> –I/O <sub>8</sub> , <b>BLE</b> controls I/O <sub>7</sub> –I/O <sub>0</sub> .
41	Input/Control	<b>OE</b> . Output Enable. Controls the direction of the I/O pins. When LOW, the I/O pins behave as outputs. When deasserted HIGH, I/O pins are tri-stated, and act as input data pins
12, 34	Ground	<b>V<sub>SS</sub></b> . Ground for the device
11, 33	Power Supply	<b>V<sub>CC</sub></b> . Power supply for the device

Notes:

- NC pins are not connected on the die.
- Typical values are included for reference only and are not guaranteed or tested. Typical values are measured at V<sub>CC</sub> = V<sub>CC(TYP)</sub>, T<sub>A</sub> = 25°C.

### Maximum Ratings

(Above which the useful life may be impaired. For user guidelines, not tested.)

Storage Temperature .....	-65°C to +150°C
Ambient Temperature with Power Applied.....	-55°C to +125°C
Supply Voltage to Ground Potential .....	-0.5V to +4.6V
DC Voltage Applied to Outputs in High-Z State <sup>[4]</sup> .....	-0.5V to $V_{CC} + 0.5V$
DC Input Voltage <sup>[4]</sup> .....	-0.5V to $V_{CC} + 0.5V$

Output Current into Outputs (LOW).....	20 mA
Static Discharge Voltage.....	> 2001V (per MIL-STD-883, Method 3015)
Latch-up Current.....	> 200 mA

### Operating Range

Range	Ambient Temperature	$V_{CC}$
Industrial	-40°C to +85°C	2.7V to 3.6V
Automotive-A	-40°C to +85°C	
Automotive-E	-40°C to +125°C	

### Electrical Characteristics Over the Operating Range

Parameter	Description	Test Conditions	-55			-70			Unit		
			Min.	Typ. <sup>[3]</sup>	Max.	Min.	Typ. <sup>[3]</sup>	Max.			
$V_{OH}$	Output HIGH Voltage	$V_{CC} = 2.7V, I_{OH} = -1.0 mA$	2.4			2.4			V		
$V_{OL}$	Output LOW Voltage	$V_{CC} = 2.7V, I_{OL} = 2.1 mA$			0.4			0.4	V		
$V_{IH}$	Input HIGH Voltage		2.2		$V_{CC} + 0.5V$	2.2		$V_{CC} + 0.5V$	V		
$V_{IL}$	Input LOW Voltage		-0.5		0.8	-0.5		0.8	V		
$I_{IX}$	Input Leakage Current	$GND \leq V_I \leq V_{CC}$	-1		+1	-1		+1	$\mu A$		
$I_{OZ}$	Output Leakage Current	$GND \leq V_O \leq V_{CC}$ , Output Disabled	-1		+1	-1		+1	$\mu A$		
$I_{CC}$	$V_{CC}$ Operating Supply Current	$I_{OUT} = 0 mA, f = f_{MAX} = 1/t_{RC}$ , CMOS Levels	$V_{CC} = 3.6V$	Ind'l	7	20		7	15	mA	
				Auto-A/ Auto-E					7		15
		$I_{OUT} = 0 mA, f = 1 MHz$ , CMOS Levels	$V_{CC} = 3.6V$	Ind'l	1	2		1	2	mA	
				Auto-A/ Auto-E					1		2
$I_{SB1}$	Automatic CE Power-down Current—CMOS Inputs	$\overline{CE} \geq V_{CC} - 0.3V, V_{IN} \geq V_{CC} - 0.3V$ or $V_{IN} \leq 0.3V, f = f_{MAX}$	$V_{CC} = 3.6V$	Ind'l		100			100	$\mu A$	
				Auto-A/ Auto-E							100
$I_{SB2}$	Automatic CE Power-down Current—CMOS Inputs	$\overline{CE} \geq V_{CC} - 0.3V, V_{IN} \geq V_{CC} - 0.3V$ or $V_{IN} \leq 0.3V, f = 0$	$V_{CC} = 3.6V$	Ind'l	1	15		1	15	$\mu A$	
				Auto-A					1		15
				Auto-E					1		20

### Capacitance<sup>[5]</sup>

Parameter	Description	Test Conditions	Max.	Unit
$C_{IN}$	Input Capacitance	$T_A = 25^\circ C, f = 1 MHz, V_{CC} = V_{CC}(typ)$	6	pF
$C_{OUT}$	Output Capacitance		8	pF

### Thermal Resistance<sup>[5]</sup>

Parameter	Description	Test Conditions	TSOPII	Unit
$\Theta_{JA}$	Thermal Resistance (Junction to Ambient)	Still Air, soldered on a 4.25 x 1.125 inch, 2-layer printed circuit board	60	$^\circ C/W$
$\Theta_{JC}$	Thermal Resistance (Junction to Case)		22	$^\circ C/W$

**Notes:**

- $V_{IL}(min.) = -2.0V$  for pulse durations less than 20 ns.
- Tested initially and after any design or process changes that may affect these parameters.

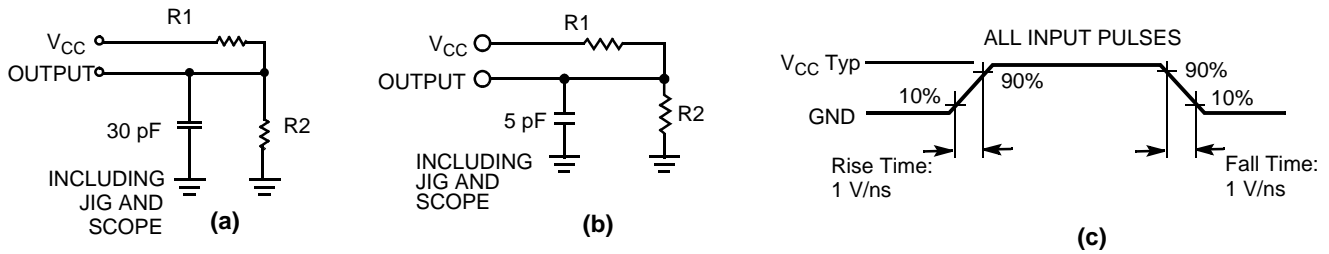
**AC Test Loads and Waveforms**

Equivalent to: THÉVENIN EQUIVALENT

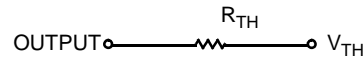

Parameters	Value	Unit
R1	1105	Ohms
R2	1550	Ohms
R <sub>TH</sub>	645	Ohms
V <sub>TH</sub>	1.75	Volts

**Data Retention Characteristics** (Over the Operating Range)

Parameter	Description	Conditions	Min.	Typ. <sup>[3]</sup>	Max.	Unit
V <sub>DR</sub>	V <sub>CC</sub> for Data Retention		1.0			V
I <sub>CCDR</sub>	Data Retention Current	V <sub>CC</sub> = 1.0V, $\overline{CE} \geq V_{CC} - 0.3V$ , V <sub>IN</sub> ≥ V <sub>CC</sub> - 0.3V or V <sub>IN</sub> ≤ 0.3V; No input may exceed V <sub>CC</sub> + 0.3V		0.5	7.5	μA
		Ind'I/Auto-A				
		Auto-E			10	
t <sub>CDR</sub> <sup>[5]</sup>	Chip Deselect to Data Retention Time		0			ns
t <sub>R</sub>	Operation Recovery Time		t <sub>RC</sub>			ns

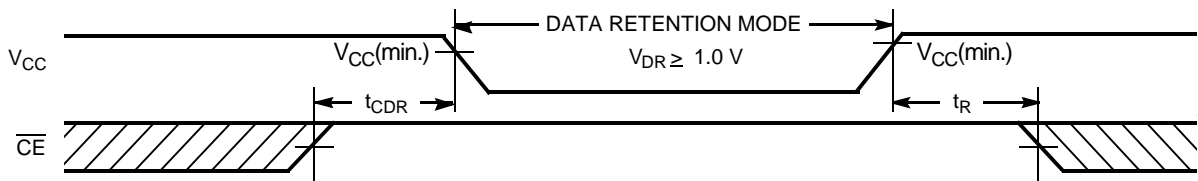
**Data Retention Waveform**

**Switching Characteristics** Over the Operating Range <sup>[6]</sup>

Parameter	Description	55 ns		70 ns		Unit
		Min.	Max.	Min.	Max.	
<b>Read Cycle</b>						
t <sub>RC</sub>	Read Cycle Time	55		70		ns
t <sub>AA</sub>	Address to Data Valid		55		70	ns
t <sub>OHA</sub>	Data Hold from Address Change	10		10		ns
t <sub>ACE</sub>	$\overline{CE}$ LOW to Data Valid		55		70	ns
t <sub>DOE</sub>	$\overline{OE}$ LOW to Data Valid		25		35	ns
t <sub>LZOE</sub>	$\overline{OE}$ LOW to Low-Z <sup>[7]</sup>	5		5		ns
t <sub>HZOE</sub>	$\overline{OE}$ HIGH to High-Z <sup>[7, 8]</sup>		25		25	ns
t <sub>LZCE</sub>	$\overline{CE}$ LOW to Low-Z <sup>[7]</sup>	10		10		ns
t <sub>HZCE</sub>	$\overline{CE}$ HIGH to High-Z <sup>[7, 8]</sup>		25		25	ns
t <sub>PU</sub>	$\overline{CE}$ LOW to Power-up	0		0		ns
t <sub>PD</sub>	$\overline{CE}$ HIGH to Power-down		55		70	ns
t <sub>DBE</sub>	$\overline{BHE}$ / $\overline{BLE}$ LOW to Data Valid		55		70	ns
t <sub>LZBE</sub> <sup>(9)</sup>	$\overline{BHE}$ / $\overline{BLE}$ LOW to Low-Z	5		5		ns
t <sub>HZBE</sub>	$\overline{BHE}$ / $\overline{BLE}$ HIGH to High-Z		25		25	ns
<b>Write Cycle<sup>[10, 11]</sup></b>						
t <sub>WC</sub>	Write Cycle Time	55		70		ns
t <sub>SCE</sub>	$\overline{CE}$ LOW to Write End	45		60		ns
t <sub>AW</sub>	Address Set-up to Write End	45		60		ns
t <sub>HA</sub>	Address Hold from Write End	0		0		ns
t <sub>SA</sub>	Address Set-up to Write Start	0		0		ns
t <sub>PWE</sub>	$\overline{WE}$ Pulse Width	40		50		ns
t <sub>SD</sub>	Data Set-up to Write End	25		30		ns
t <sub>HD</sub>	Data Hold from Write End	0		0		ns
t <sub>HZWE</sub>	$\overline{WE}$ LOW to High-Z <sup>[7, 8]</sup>		20		25	ns
t <sub>LZWE</sub>	$\overline{WE}$ HIGH to Low-Z <sup>[7]</sup>	5		10		ns
t <sub>BW</sub>	$\overline{BHE}$ / $\overline{BLE}$ LOW to End of Write	50		60		ns

**Notes:**

6. Test conditions assume signal transition time of 5 ns or less, timing reference levels of 1.5V, input levels of 0 to V<sub>CC</sub> typ., and output loading of the specified I<sub>OL</sub>/I<sub>OH</sub> and 30 pF load capacitance.
7. At any given temperature and voltage condition, t<sub>HZCE</sub> is less than t<sub>LZCE</sub>, t<sub>HZOE</sub> is less than t<sub>LZOE</sub>, and t<sub>HZWE</sub> is less than t<sub>LZWE</sub> for any given device.
8. t<sub>HZOE</sub>, t<sub>HZCE</sub>, and t<sub>HZWE</sub> are specified with C<sub>L</sub> = 5 pF as in (b) of AC Test Loads. Transition is measured ±500 mV from steady-state voltage.
9. If both byte enables are toggled together this value is 10 ns.
10. The internal write time of the memory is defined by the overlap of  $\overline{CE}$  LOW and  $\overline{WE}$  LOW. Both signals must be LOW to initiate a write and either signal can terminate a write by going HIGH. The data input set-up and hold timing should be referenced to the rising edge of the signal that terminates the write.
11. The minimum write cycle time for write cycle #3 (WE controlled, OE LOW) is the sum of t<sub>HZWE</sub> and t<sub>SD</sub>.

### Switching Waveforms

#### Read Cycle No. 1<sup>[12, 13]</sup>

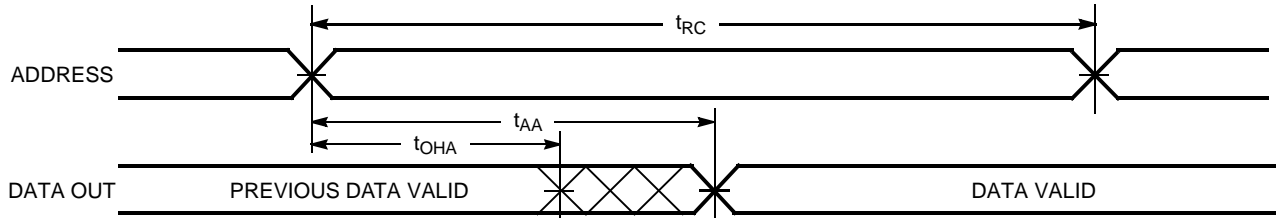

#### Read Cycle No. 2<sup>[13, 14]</sup>

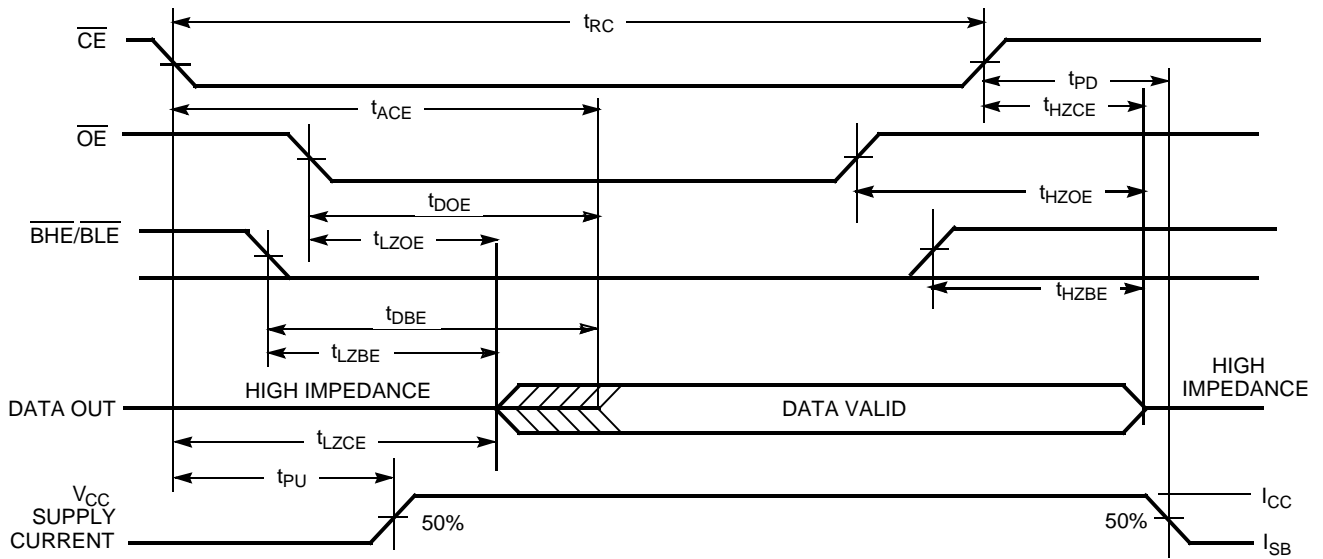

**Notes:**

- 12. Device is continuously selected.  $\overline{OE}, \overline{CE} = V_{IL}$ .
- 13.  $\overline{WE}$  is HIGH for read cycle.
- 14. Address valid prior to or coincident with  $\overline{CE}$  transition LOW.

**Switching Waveforms** (continued)

**Write Cycle No. 1 (WE Controlled)**<sup>[10, 15, 16]</sup>

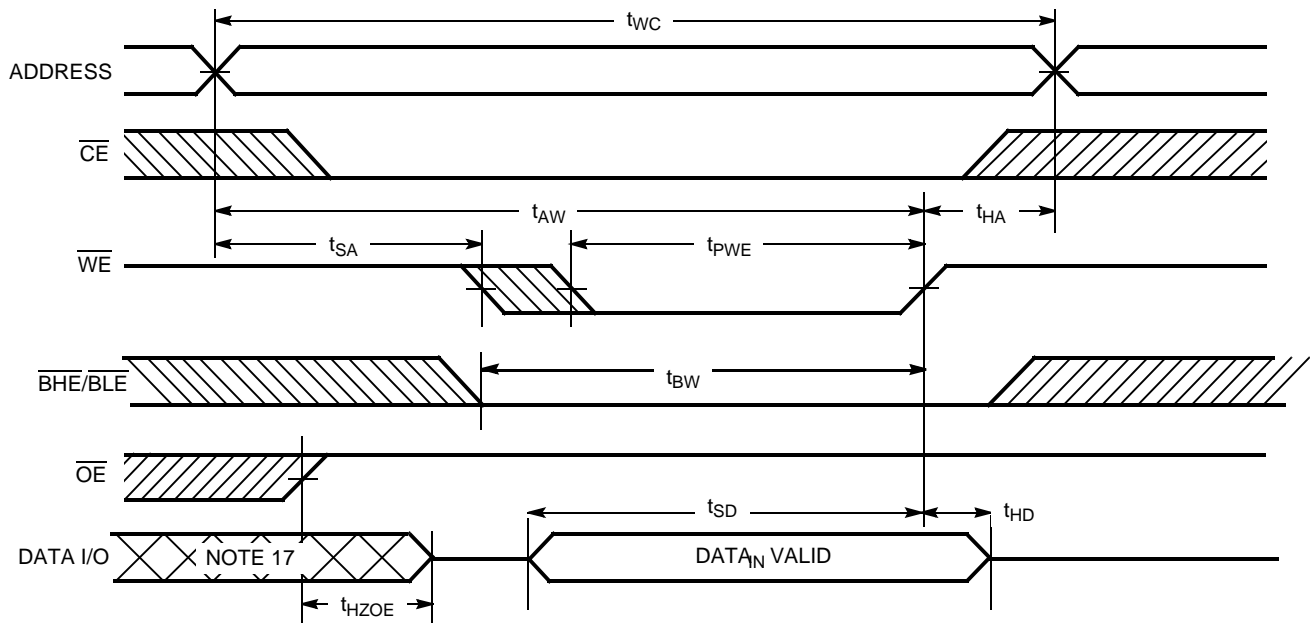

**Write Cycle No. 2 (CE Controlled)**<sup>[10, 15, 16]</sup>

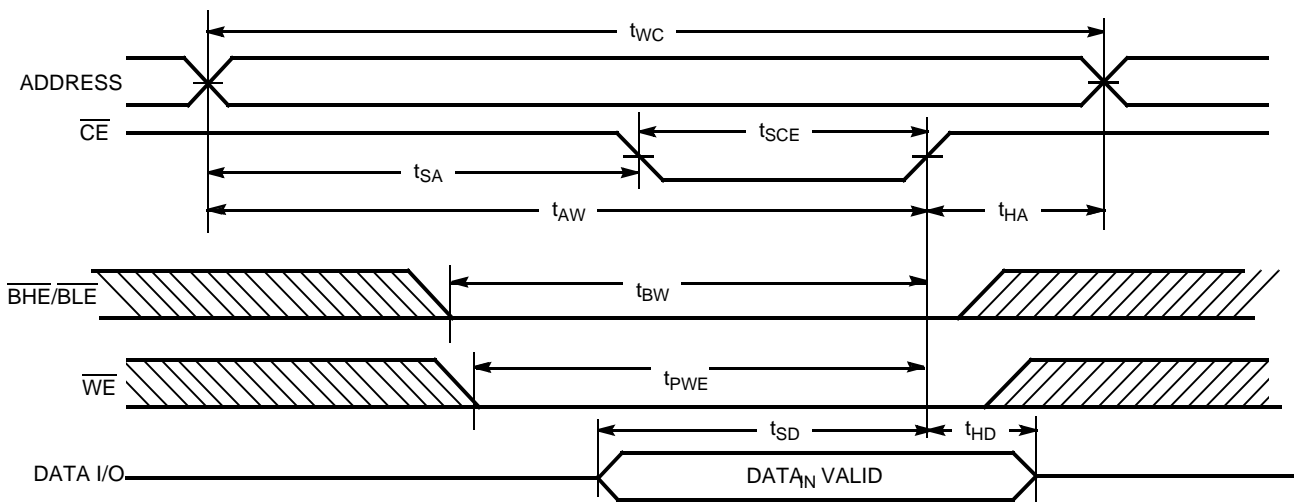

**Notes:**

- 15. Data I/O is high-impedance if  $\overline{OE} = V_{IH}$ .
- 16. If  $\overline{CE}$  goes HIGH simultaneously with WE HIGH, the output remains in a high-impedance state.
- 17. During this period, the I/Os are in output state and input signals should not be applied.

**Switching Waveforms** (continued)

**Write Cycle No. 3 ( $\overline{WE}$  Controlled,  $\overline{OE}$  LOW)<sup>[11, 16]</sup>**

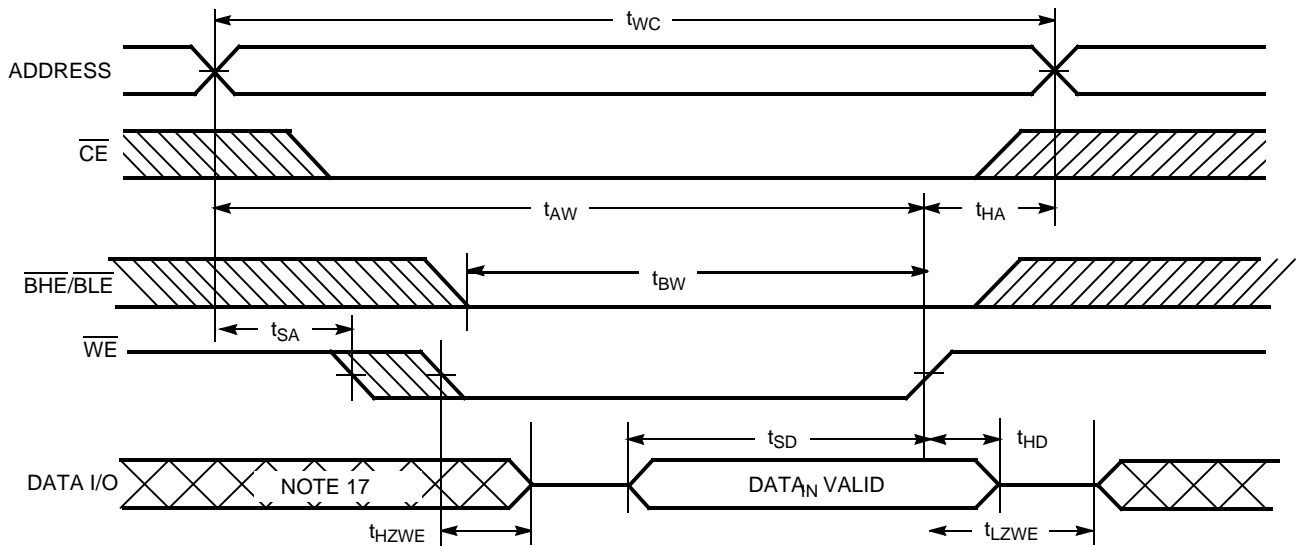

**Write Cycle No. 4 ( $\overline{BHE}/\overline{BLE}$  Controlled,  $\overline{OE}$  LOW)<sup>[17]</sup>**

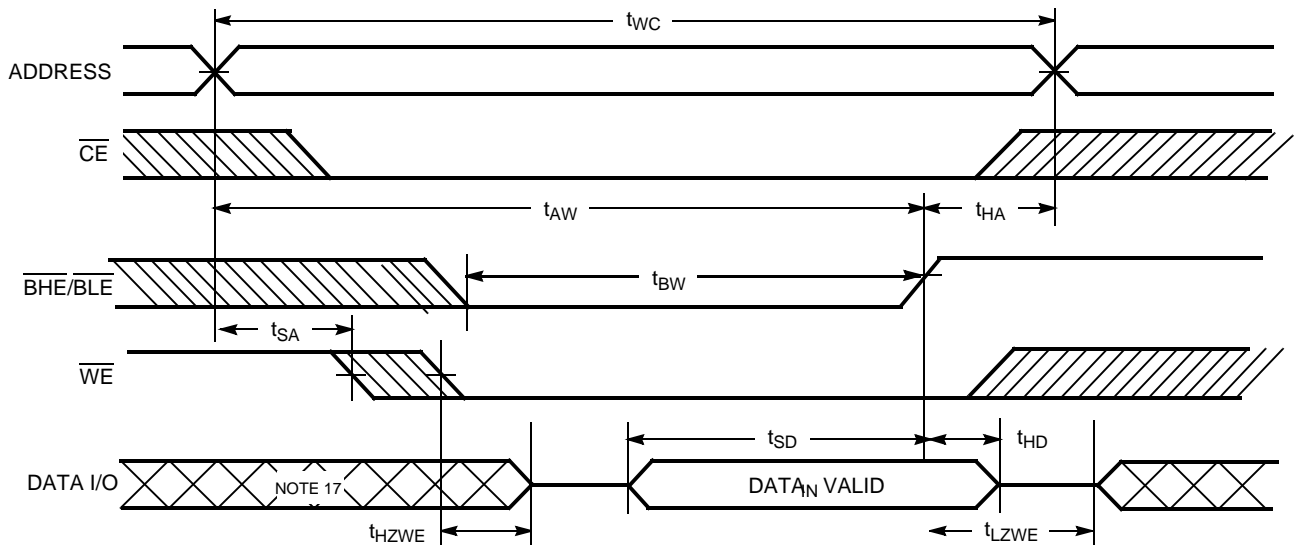

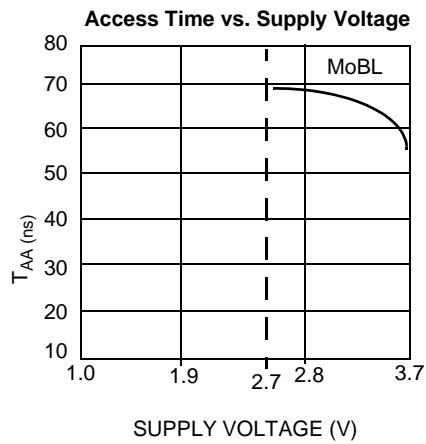
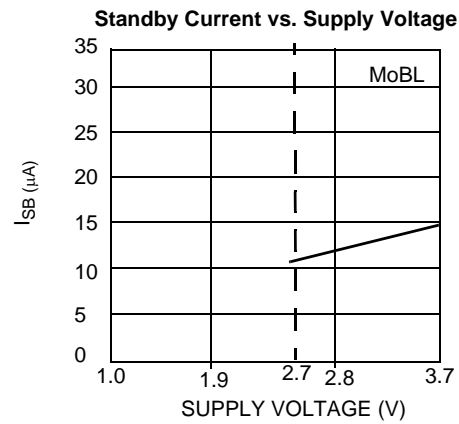
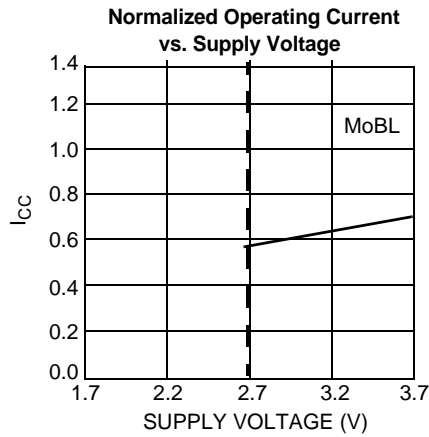
**Typical DC and AC Characteristics**

**Truth Table**

$\overline{CE}$	$\overline{WE}$	$\overline{OE}$	$\overline{BHE}$	$\overline{BLE}$	$I/O_8-I/O_{15}$	$I/O_0-I/O_7$	Mode	Power
H	X	X	X	X	High-Z	High-Z	Deselect/Power-down	Standby ( $I_{SB}$ )
X	X	X	H	H	High-Z	High-Z	Deselect/Power-down	Standby ( $I_{SB}$ )
L	H	L	L	L	Data Out	Data Out	Read	Active ( $I_{CC}$ )
L	H	L	H	L	High-Z	Data Out	Read	Active ( $I_{CC}$ )
L	H	L	L	H	Data Out	High-Z	Read	Active ( $I_{CC}$ )
L	H	H	X	X	High-Z	High-Z	Output Disabled	Active ( $I_{CC}$ )
L	L	X	L	L	Data In	Data In	Write	Active ( $I_{CC}$ )
L	L	X	H	L	High-Z	Data In	Write	Active ( $I_{CC}$ )
L	L	X	L	H	Data In	High-Z	Write	Active ( $I_{CC}$ )

**Ordering Information**

Speed (ns)	Ordering Code	Package Diagram	Package Type	Operating Range
55	CY62137VNLL-55ZXI	51-85087	44-pin TSOP II (Pb-free)	Industrial
70	CY62137VNLL-70ZXI		44-pin TSOP II (Pb-free)	Industrial
	CY62137VNLL-70ZSXA		44-pin TSOP II (Pb-free)	Automotive-A
	CY62137VNLL-70ZSXE		44-pin TSOP II (Pb-free)	Automotive-E

Please contact your local Cypress sales representative for availability of these parts

**Package Diagram**

**44-Pin TSOP II (51-85087)**

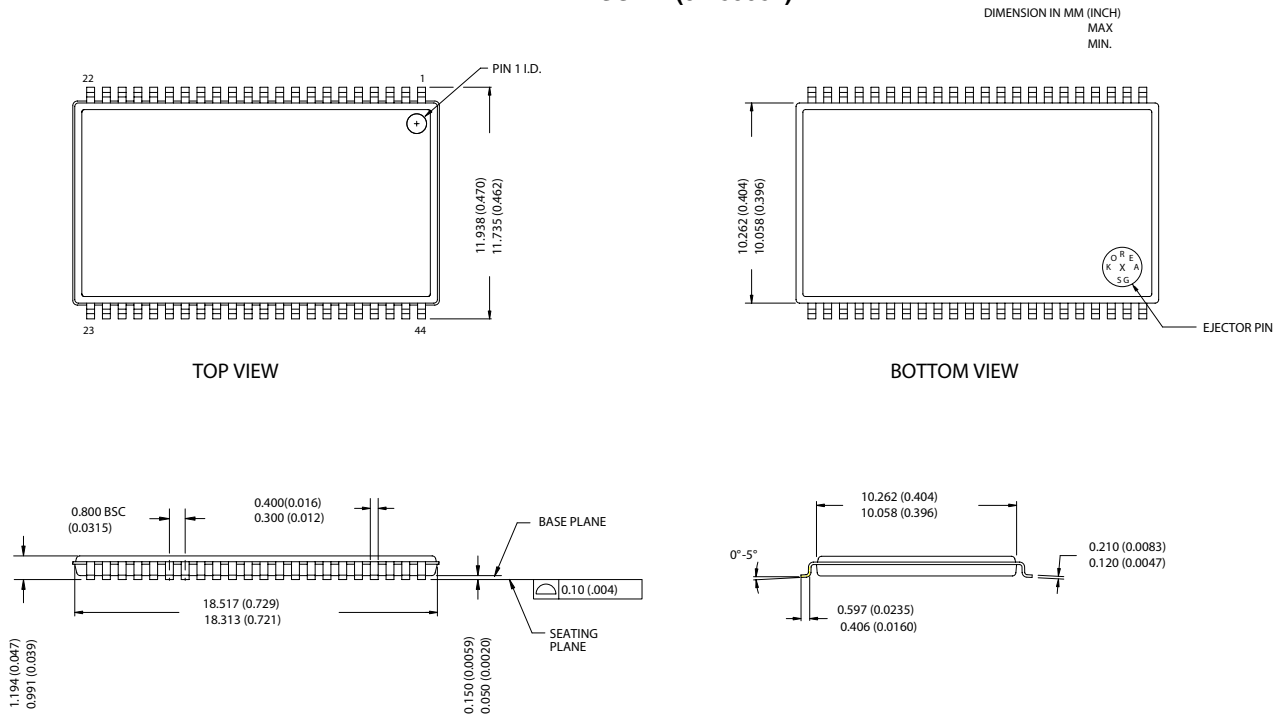

51-85087-\*A



MoBL is a registered trademark, and More Battery Life is a trademark, of Cypress Semiconductor Corporation. All product and company names mentioned in this document are the trademarks of their respective holders.

**Document History Page**

<b>Document Title: CY62137VN MoBL<sup>®</sup> 2-Mbit (128K x 16) Static RAM</b>				
<b>Document Number: 001-06497</b>				
<b>REV.</b>	<b>ECN NO.</b>	<b>Issue Date</b>	<b>Orig. of Change</b>	<b>Description of Change</b>
**	426503	See ECN	NXR	New Data Sheet
*A	488954	See ECN	NXR	Added Automotive product Updated Ordering Information table

## Looking for pricing, stock, or lifecycle information?

Click below to explore more details on WIN SOURCE:

-  [View CY62137VNLL-70ZSXET on WIN SOURCE](#)
-  [Cypress Semiconductor Corp Information](#)

## Optimize Your Supply Chain with WIN SOURCE Solutions

-  Global Sourcing Solution
-  Obsolete Management
-  Cost Control Management
-  Shortage Management
-  Alternative Solution
-  Excess Inventory Management